



**TRAILER MOUNTED PUMP MODEL C50HP
DRIVE CYLINDER CIRCUIT
HYDRAULIC COMPONENTS**

SCMTC

PAGE 01

Code	Description	Part No.	Qty
DRIVE CYLINDER CIRCUIT			
P1	Main Pump - 100 cc	75864	1
PCP1	Pressure Control Pilot Valve	77040	1
CYL1	Hydraulic Drive Cylinder-3.50x2.00x41	86222	2
C1	Check Valve	78961	4
C2			
C3	Check Valve	77282	1
HOS1	Hot Oil Shuttle Valve	72980	1
RV1	Pressure Limiter Valve	800074	2
G1	Pressure Gauge - 6000 psi	74562	1
OC1	Oil Cooler	86078	1
RF1	Return Filter	85282	1
	Return Filter Element	85283	1
G3	Pressure Gauge - Return	85575	1
SS1	Magnetic Suction Strainer	79247	1
S-TUBE CIRCUIT			
P2	Tandem Gear Pump - 12/10cc	73156	1
	Gear Pump -5.5cc	87153	1
CYL2	S-Tube Shift Cylinder-2.50x5.75	86220	2
MAN2	Manifold - S-Tube Circuit(#86821 Manifold Only)	85249 ASSY	1
SV2	Solenoid Valve - S-Tube Circuit	85693	1
SV2-1	Solenoid Valve - Main	85694	1
SV2-2	Solenoid Valve - Pilot	85695	1
	Coil for SV2-2	85692	2
SV3	Solenoid Valve Cartridge	87246	1
	Coil for SV3	87247	1
SV4	Solenoid Valve Cartridge	87248	1
	Coil for SV4	87249	1
RV2	Relief Valve Cartridge	85703	1
UV1	Unloader Valve Cartridge	85704	1
BV1	Ball Valve	85705	1
ACC1	Accumulator	74515	1
G2	Pressure Gauge - 3000 psi	70366	1
SS2	Magnetic Suction Strainer	79247	1
AGITATOR / OUTRIGGER CIRCUIT			
DV3	Directional Valve - Agitator / Outrigger	74471	1
RV3	Relief Valve Cartridge	85706	1
SV5	Solenoid Valve	87154	1
	Coil for SV5	87155	1
M1	Agitator Motor - 747cc (Standard Hopper)	85811	1
CYL3	Hydraulic Outrigger Cylinder-2.00x12.00	86574	2
SS3	Magnetic Suction Strainer	79247	1

REVISION:



TRAILER MOUNTED PUMP MODEL C50HP
DRIVE CYLINDER CIRCUIT
HYDRAULIC SCHEMATIC

SCMTC

PAGE 02

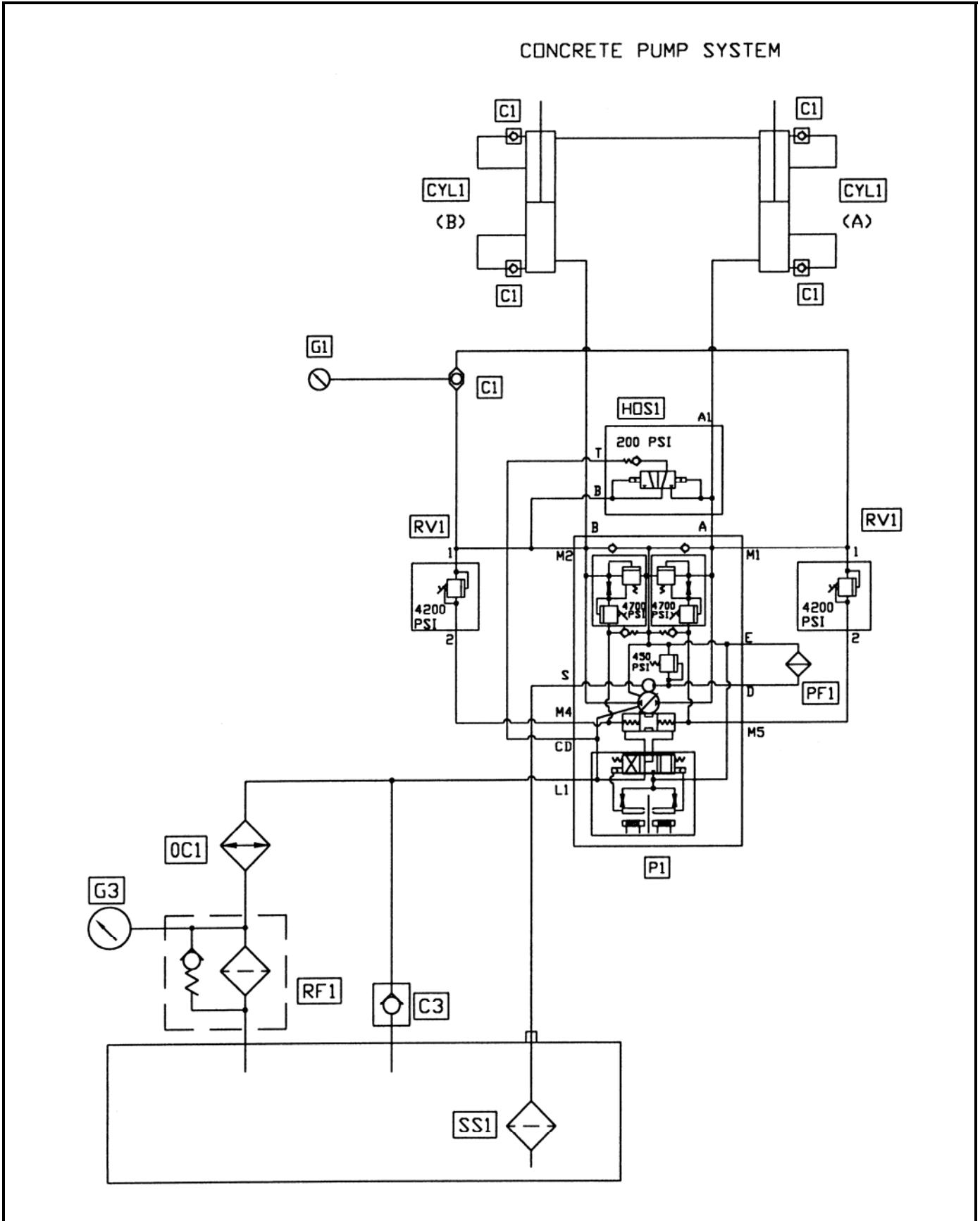

REVISION:



TRAILER MOUNTED PUMP MODEL C50HP
DUAL SHIFT SWING TUBE CIRCUIT
HYDRAULIC SCHEMATIC

SCMTC

PAGE 03

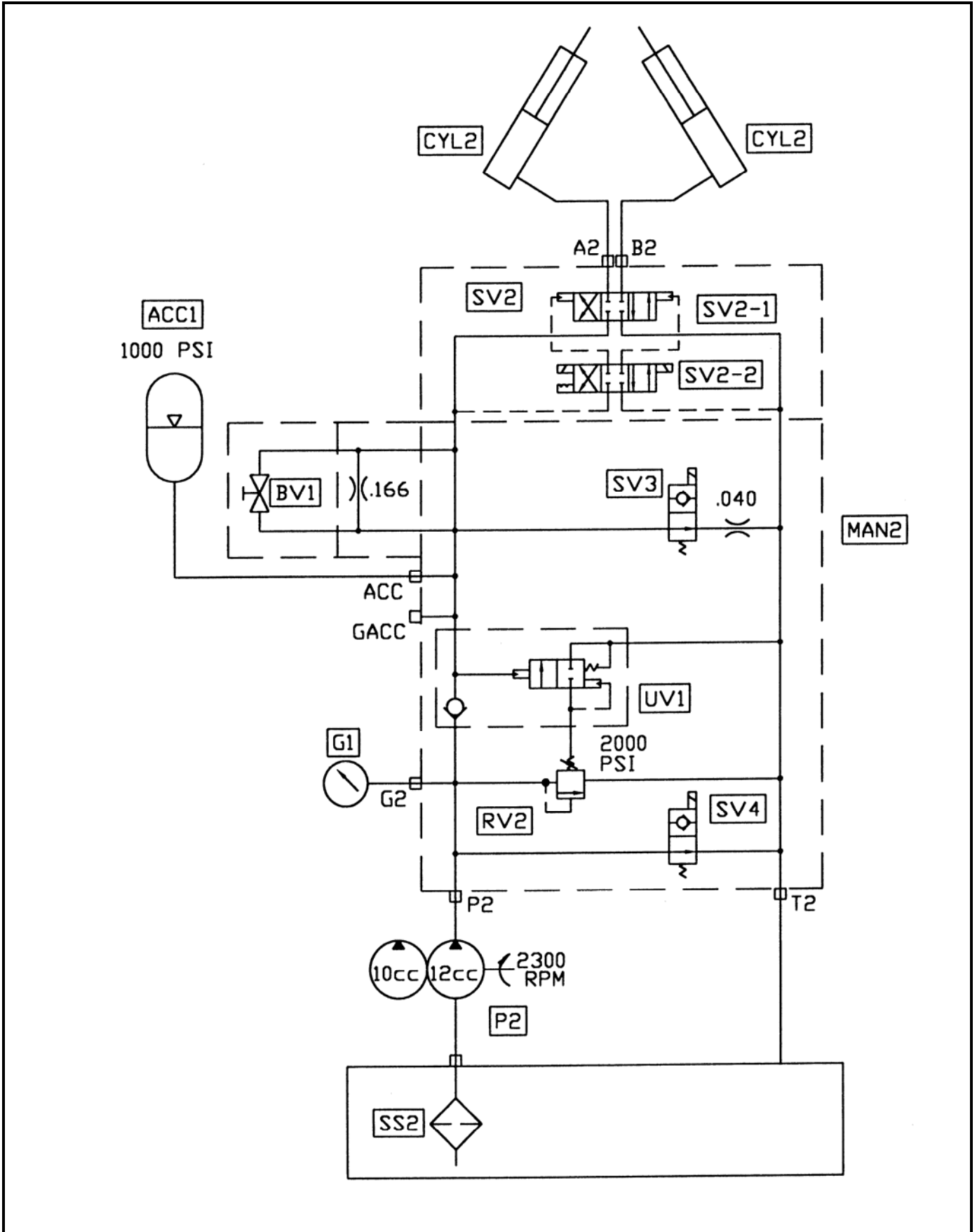

REVISION:



TRAILER MOUNTED PUMP MODEL C50HP AGITATOR / OUTRIGGER OPTION CIRCUIT HYDRAULIC SCHEMATIC

SCMTC

PAGE 04

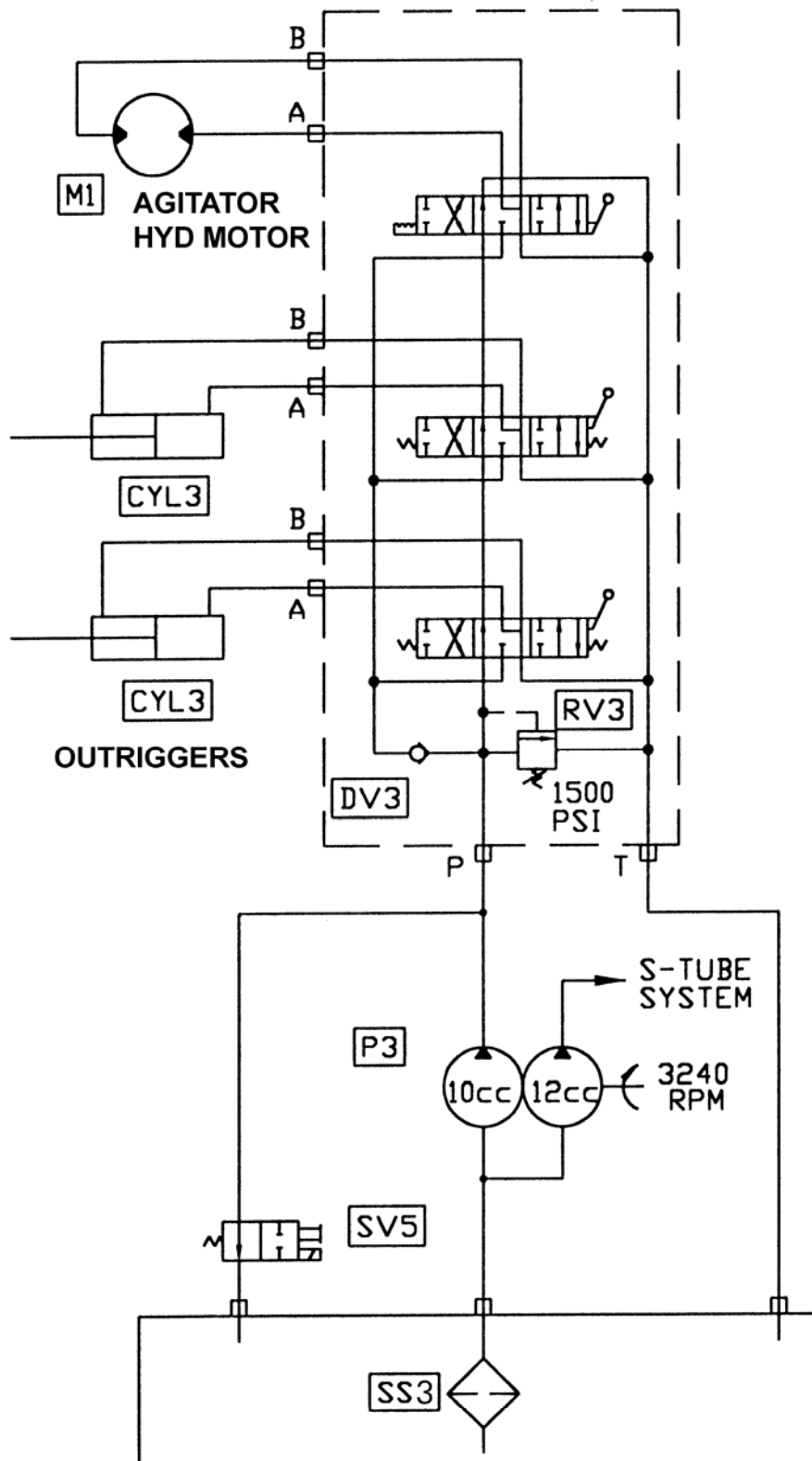

REVISION:



**TRAILER MOUNTED PUMP MODEL C50HP
ELECTRICAL COMPONENTS (1 OF 2)**

Code	Description	Part No.	Qty	Location
SWITCHES				
1S1	Key Switch	71154	1	Control Panel
2S2	Toggle Switch, Horn	85347	1	Control Panel
2S10	Toggle Switch, Cyl Chg-Over Fast/Slow	72963	1	Control Panel
3S3	Toggle Switch, Local/Remote	78563	1	Control Panel
3S4	Toggle Switch, Pump On/Reverse	72003	1	Control Panel
3S5	Toggle Switch, Test A/B	85346	1	Control Panel
3S6	E-Stop Switch	85342	1	Control Panel
	Contact Block, 1NC for 3S6	85343	1	Control Panel
3S7	E-Stop Switch	85342	1	Remote Control
	Contact Block, 1NC for 3S7	85343	1	Remote Control
3S8	Toggle Switch, Horn	85347	1	Remote Control
3S9	Toggle Switch, Pump On/Reverse	72003	1	Remote Control
RELAYS				
1K1	Relay, Engine Start	85348	1	Engine
LIGHTS				
1L1	Light, Green, Control On	85355	1	Control Panel
1L2	Light, Red, Oil Temperature	73775	1	Control Panel
1L4	Light, Red, Oil Pressure	73775	1	Control Panel
1L5	Light, Red, Alternator	73775	1	Control Panel
	Bulb for 1L2, 1L3, 1L4, 1L5	72022	4	Control Panel
2L6	Bulb, E-Stop	85344	1	Control Panel
2L7	Light, Green, Local	85355	1	Control Panel
3L8	Light, Yellow, Remote	85356	1	Control Panel
3L9	Light, Green, Pump On	85355	1	Control Panel
3L10	Light, Green, Reverse	85355	1	Control Panel
3L11	Bulb, E-Stop	85344	1	Remote Control
3L12	Light, Green, Pump On	85355	1	Remote Control
GAUGES				
1G1	Hour Meter	74240	1	Control Panel
1G2	Tachometer	78687	1	Control Panel

REVISION:



**TRAILER MOUNTED PUMP MODEL C50HP
ELECTRICAL COMPONENTS (2 OF 2)**

Code	Description	Part No.	Qty	Location
FUSES				
1F1	Fuse, 25A	800447	1	Control Panel
1F2	Fuse, 20A	800448	1	Control Panel
1F3	Fuse, 5A	90392	1	Control Panel
2F4	Fuse, 10A	800449	1	Control Panel
2F5	Fuse, 10A	800449	1	Control Panel
2F6	Fuse, 5A	90392	1	Control Panel
2F8	Fuse, 10A	800449	1	Control Panel
	Fuse Block, 8 Way	85354	1	Control Panel
SOLENOID VALVE COILS				
1Y1	Coil, Fuel Solenoid	Deutz	1	Engine
1Y2	Coil, Accumulator Bypass	85700	1	S-Tube Manifold
1Y3	Coil, S-Tube Bypass	85702	1	S-Tube Manifold
1Y4	Coil, Agitator Bypass	73184	1	Hyd. Tank
2Y5	Coil, EDC	85692	1	Main Pump
2Y7	Coil, S-Tube Shift "A"	85692	1	Pump Manifold
2Y8	Coil, S-Tube Shift "B"	85692	1	Pump Manifold
	Plugs for 1Y2, 1Y3, 1Y4, 2Y7, 2Y8	74597	5	Manifolds
MISCELLANEOUS				
2BB1	Black Box, Pump Control	85334	1	Control Box
2BB2	Black Box, E-Stop Logic	85596	1	Control Box
2P1	Proximity Switch, Cyl "B"	77998	1	Water Box
2P2	Proximity Switch, Cyl "A"	77998	1	Water Box
2H1	Horn	800347	1	Control Box
3R1	Resistor, 100 Ohm	72777	1	Remote Control
3R2	Resistor, 100 Ohm	72777	1	Control Box
3R3	Potentiometer, 100 Ohm	77642	1	Control Box
3R4	Potentiometer, 100 Ohm	77642	1	Remote Control
CONNECTORS				
X1	Connector Insert, 24 Pin, Female	78696	1	Control Box
X1	Connector Base	78697	1	Control Box
X1	Connector Insert, 24 Pin, Male	78695	1	Harness
X1	Connector Hood	800424	1	Harness
X2	Terminal Block	72820	8	Control Box
X3	Connector Insert, 10 Pin, Female	79963	1	Control Box
X3	Connector Base	79965	1	Control Box
X3	Connector Insert, 10 Pin, Male	79964	1	Remote Control
X3	Connector Hood	79966	1	Remote Control
X4	Connector, Engine	72779	1	Harness
X6	Connector, Pump	72906	1	Harness



TRAILER MOUNTED PUMP MODEL C50HP ELECTRICAL SCHEMATIC (1 OF 3)

SCMTC

PAGE 07

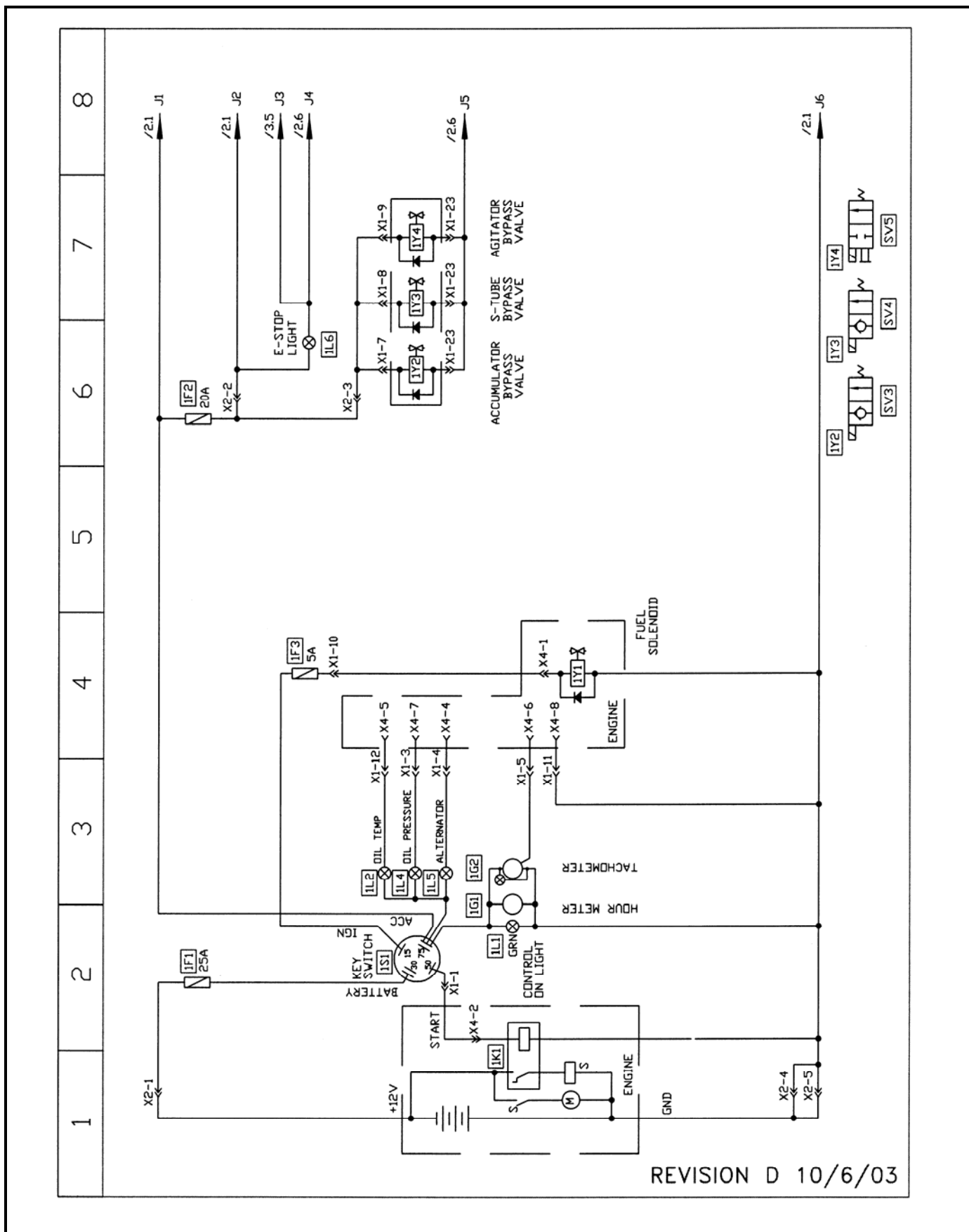

REVISION D 10/6/03

REVISION:



TRAILER MOUNTED PUMP MODEL C50HP ELECTRICAL SCHEMATIC (2 OF 3)

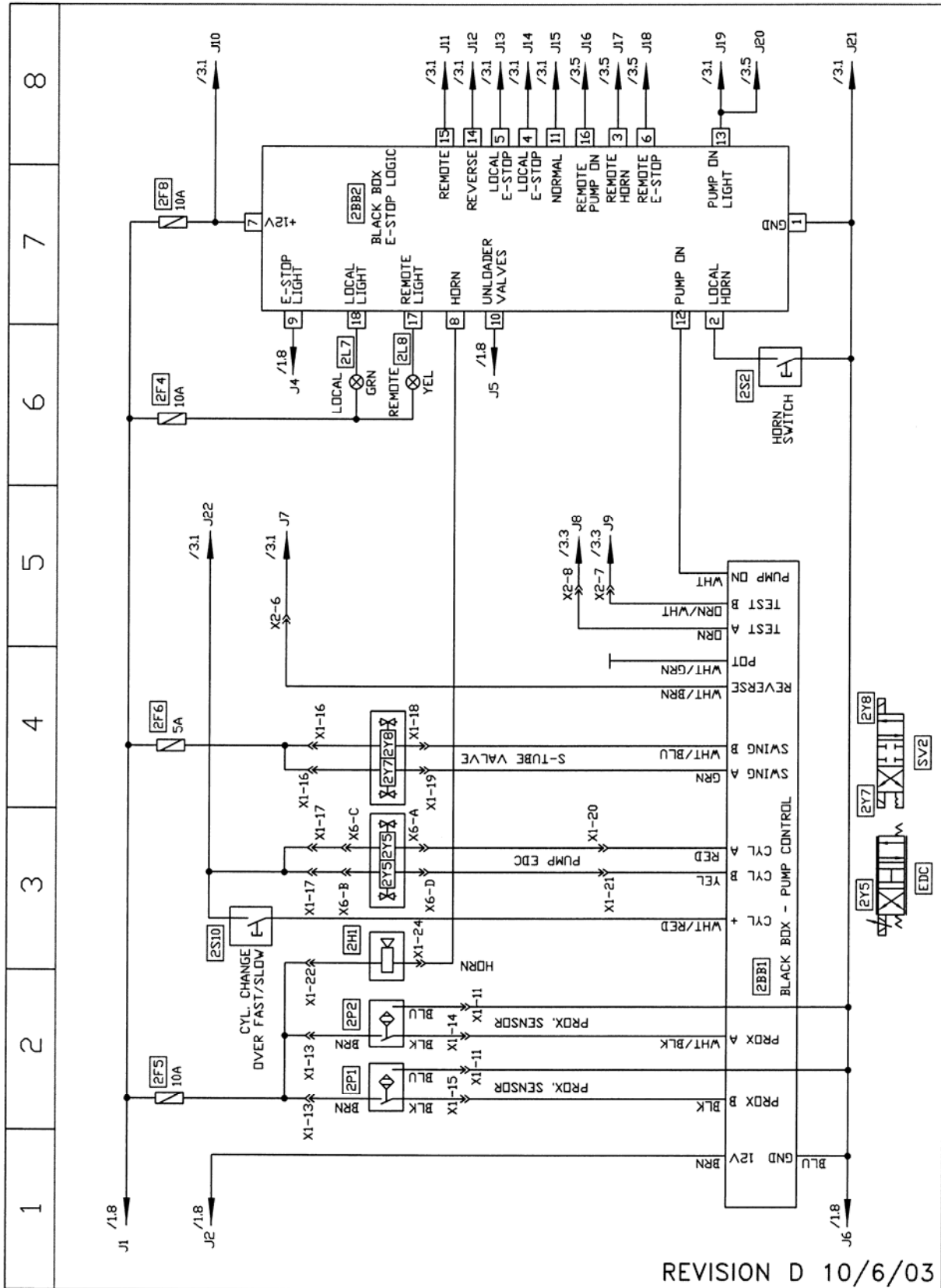

REVISION:



TRAILER MOUNTED PUMP MODEL C50HP ELECTRICAL SCHEMATIC (3 OF 3)

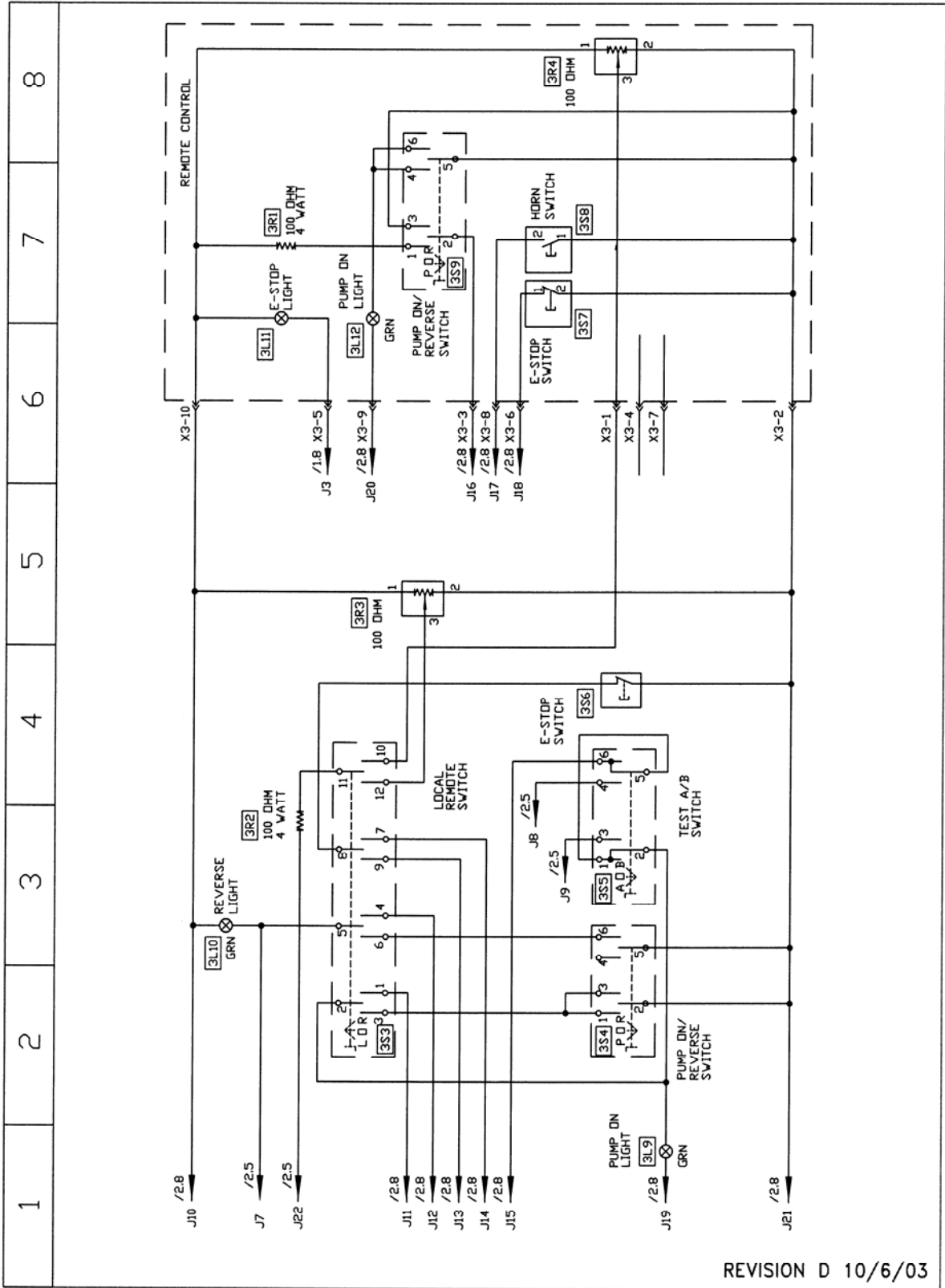

REVISION D 10/6/03

REVISION:



TRAILER MOUNTED PUMP MODEL C50HP CONTROL BOX ELECTRICAL COMPONENTS

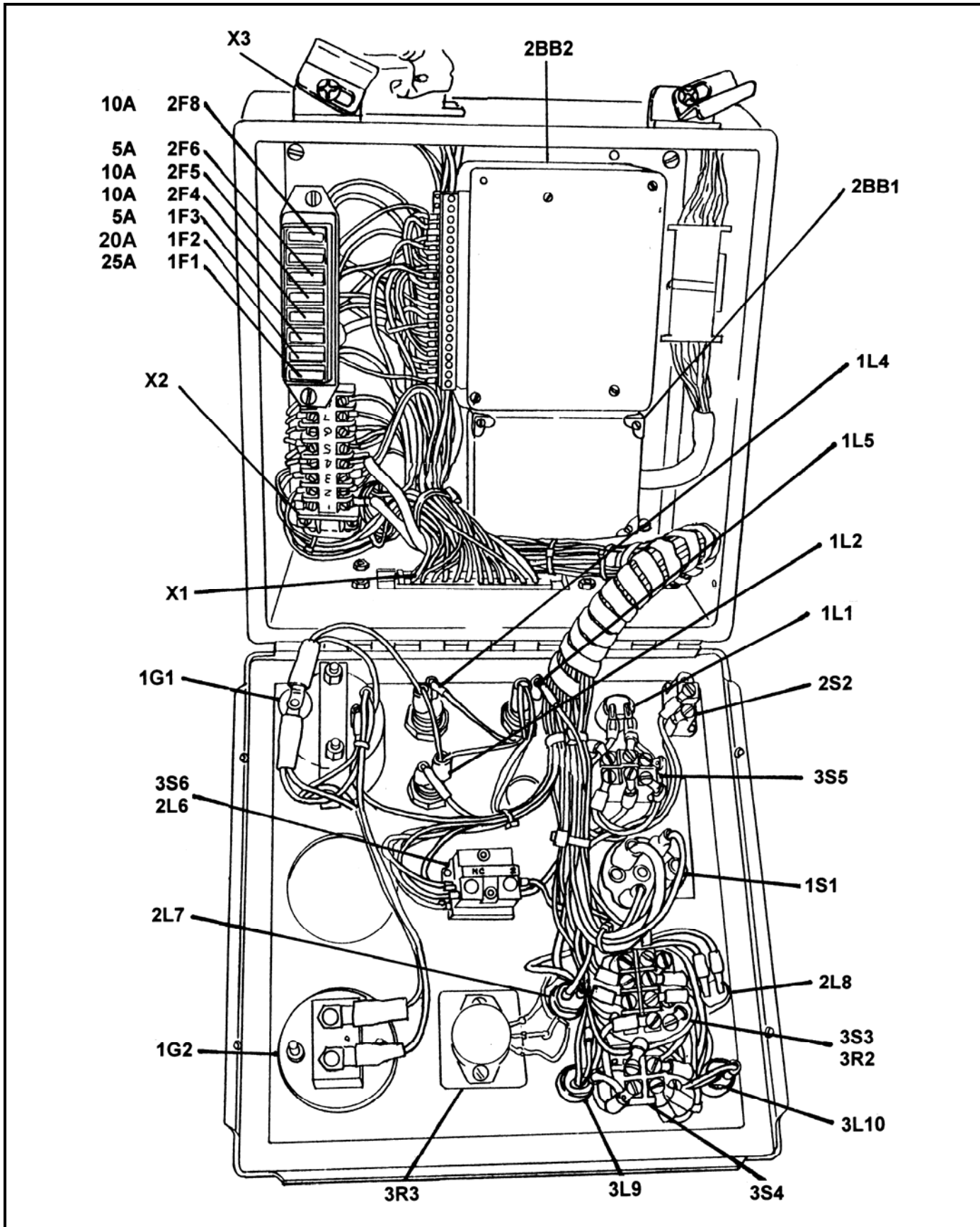

REVISION:



TRAILER MOUNTED PUMP MODEL *C50HP*
WIRE PROCEDURE
FOR POTENTIOMETER

LOOKING FROM THE BACK OF THE COMPONENT

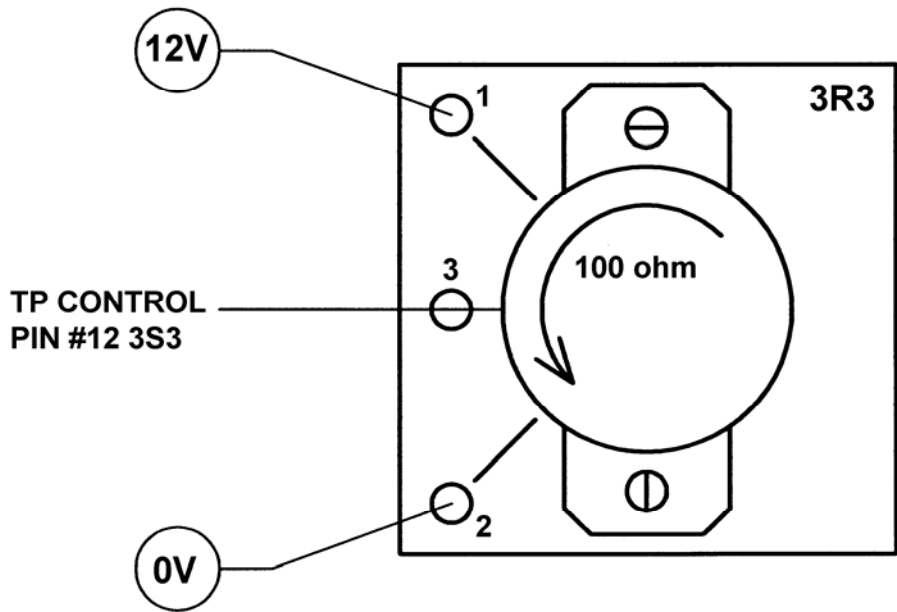

WIRE PROCEDURE FOR POTENTIOMETER
USED ON C-SERIES CONTROL BOXES



TRAILER MOUNTED PUMP MODEL C50HP
CABLE REMOTE CONTROL ASSEMBLY

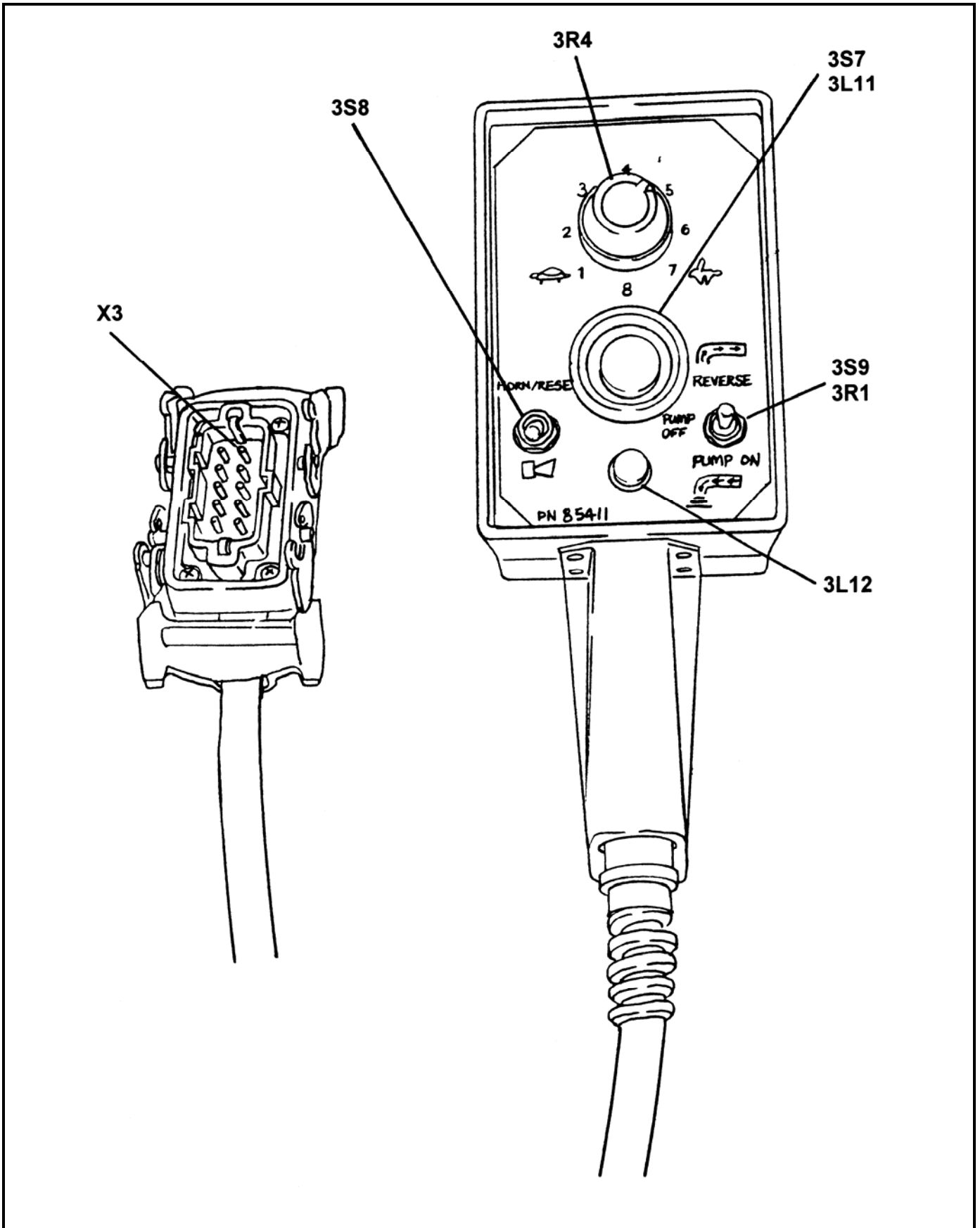

REVISION:



TRAILER MOUNTED PUMP MODEL C50HP WIRING HARNESS

SCMTC

PAGE 13

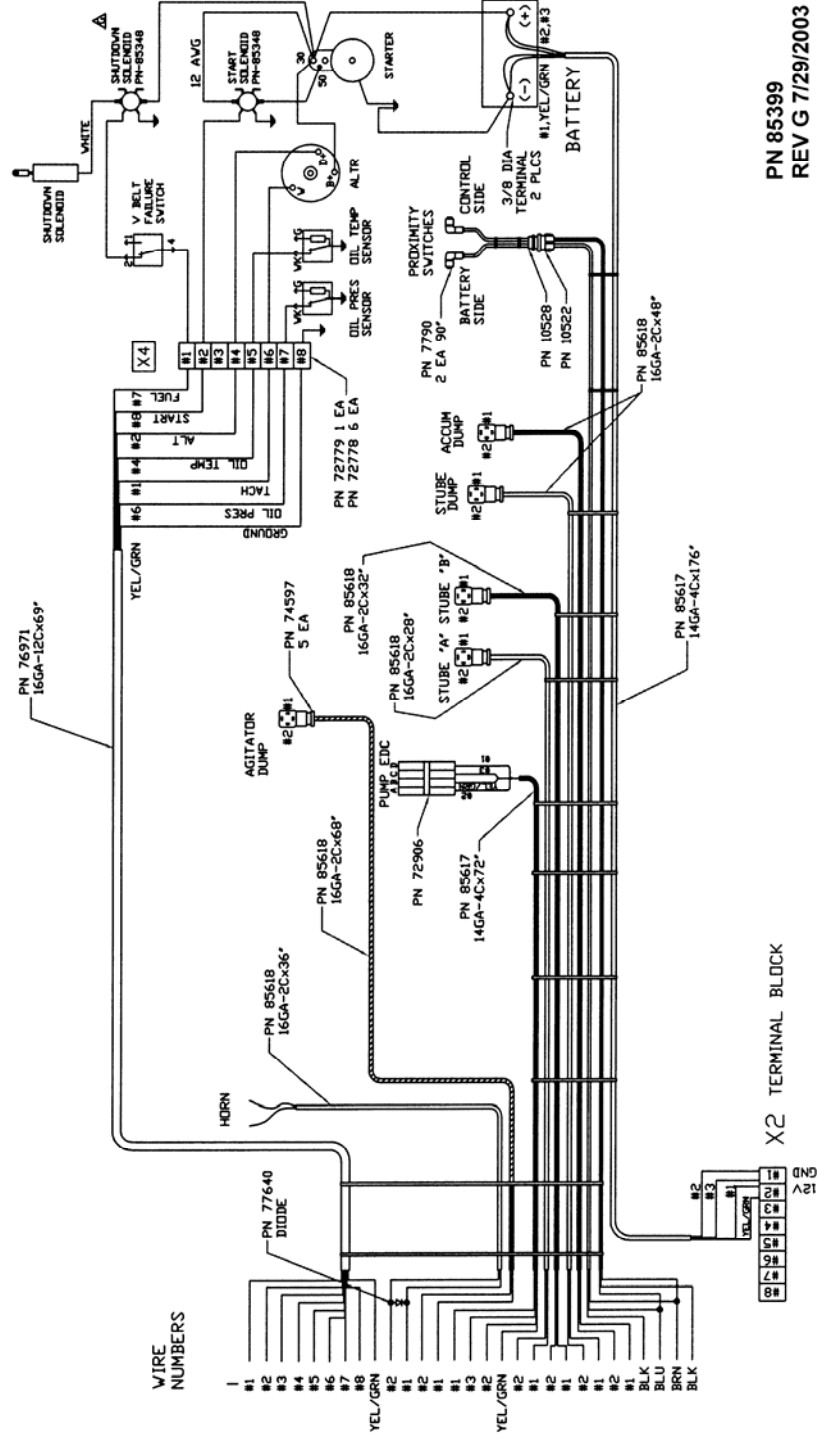

PN 85399
REV G 7/29/2003

- PN 800424 HOOD
PN 78695 INSERT
PN 801479 CONNECTOR
- 24 PIN PLUG X1
- | | |
|----|-----------------|
| 1 | TACHMETER |
| 2 | ALTERNATOR |
| 3 | OIL TEMP |
| 4 | OIL PRESSURE |
| 5 | FUEL SOLENOID |
| 6 | ENG. START |
| 7 | GROUND |
| 8 | GROUND |
| 9 | HORN + |
| 10 | HORN - |
| 11 | AGITATOR DUMP - |
| 12 | AGITATOR DUMP + |
| 13 | AGITATOR DUMP + |
| 14 | DRIVE CYL 'B' - |
| 15 | DRIVE CYL 'B' + |
| 16 | DRIVE CYL 'A' - |
| 17 | DRIVE CYL 'A' + |
| 18 | EDC INPUT + |
| 19 | EDC INPUT + |
| 20 | STUBE 'A' - |
| 21 | STUBE 'A' + |
| 22 | STUBE 'B' - |
| 23 | STUBE 'B' + |
| 24 | STUBE DUMP - |
| 25 | STUBE DUMP + |
| 26 | STUBE DUMP + |
| 27 | ACCUM DUMP + |
| 28 | ACCUM DUMP + |
| 29 | PRDX SWITCH 'B' |
| 30 | GROUND |
| 31 | PRDX SWITCH 'A' |
| 32 | PRDX SWITCH 'A' |

REVISION:



TRAILER MOUNTED PUMP MODEL C50HP TRAILER HARNESS

SCMTC

PAGE 14

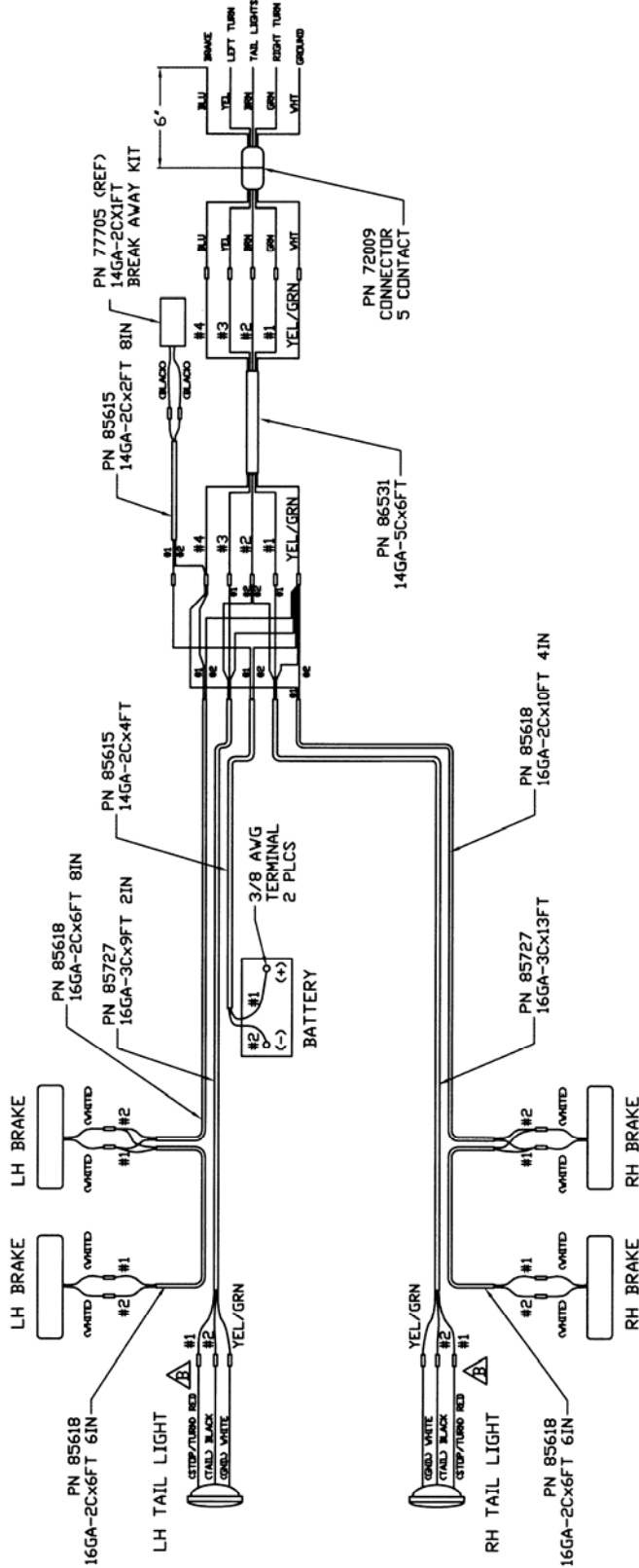

PN 86532 REV-B

- NOTES:
1. ALL CONNECTIONS SOLDERED AND INSULATED WITH HEAT SHRINK TUBING.

REVISION:



TRAILER MOUNTED PUMP MODEL C50HP
 RADIO REMOTE CONTROL OPTION
 WIRING DIAGRAM

SCMTC

PAGE 15

X3 PIN	FUNCTION
1	
2	GROUND
3	PUMP ON/REV.
4	
5	
6	'E' STOP
7	
8	HORN
9	
10	+12 vdc

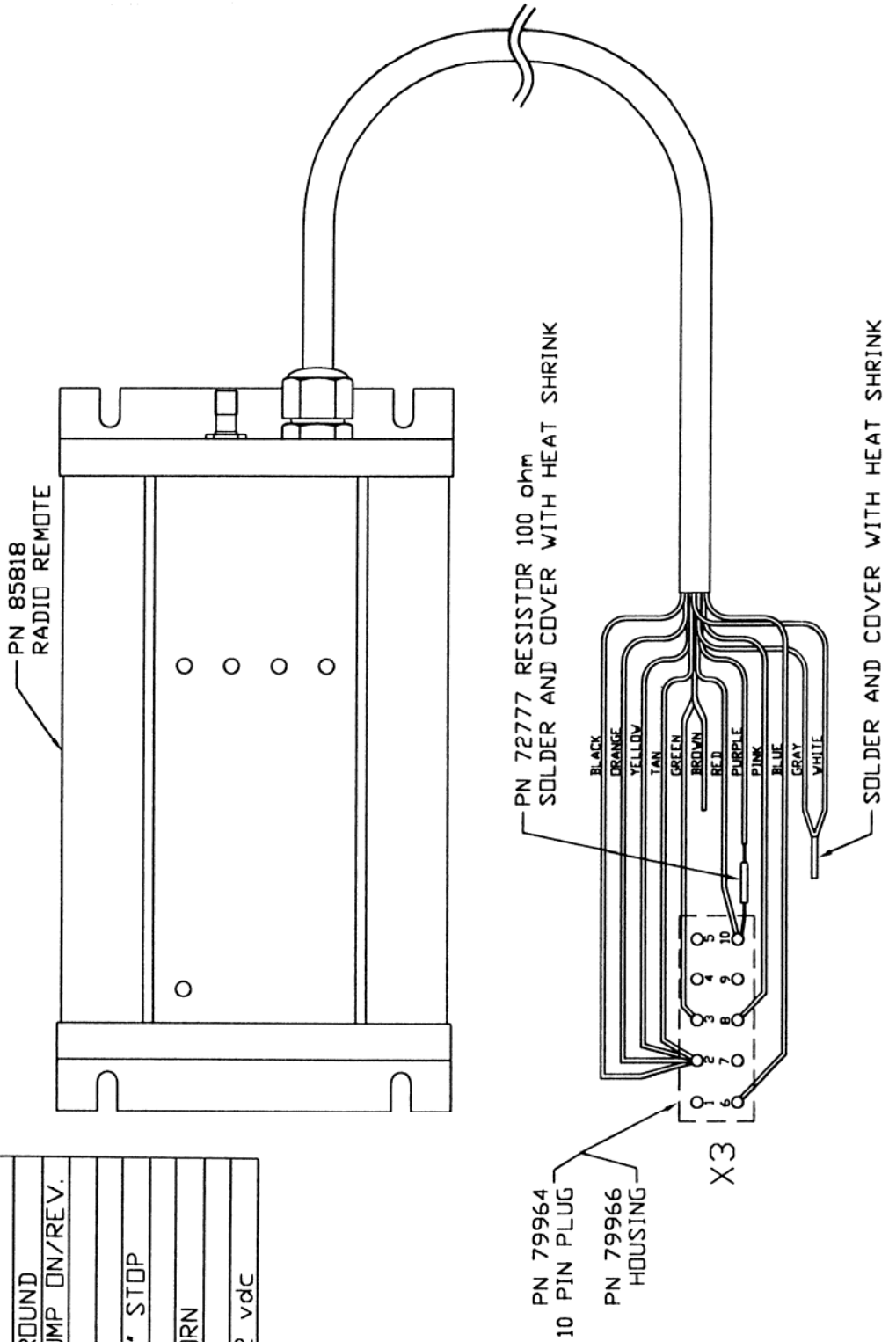

REVISION:



TRAILER MOUNTED PUMP MODEL C50HP HOPPER VIBRATOR ELECTRICAL SCHEMATIC

SCMTC

PAGE 16

1	2	3	4	5	6	7	8
---	---	---	---	---	---	---	---

CODE	PART NO.	DESCRIPTION
M1	71429	VIBRATOR
K1	W-105618	RELAY
S1	72965	TOGGLE SWITCH
F1	85839	FUSE - 30A
D1	776404	DIODE
X1	85899	RECEPTACLE
X1	85898	CABLE V/ PLUG

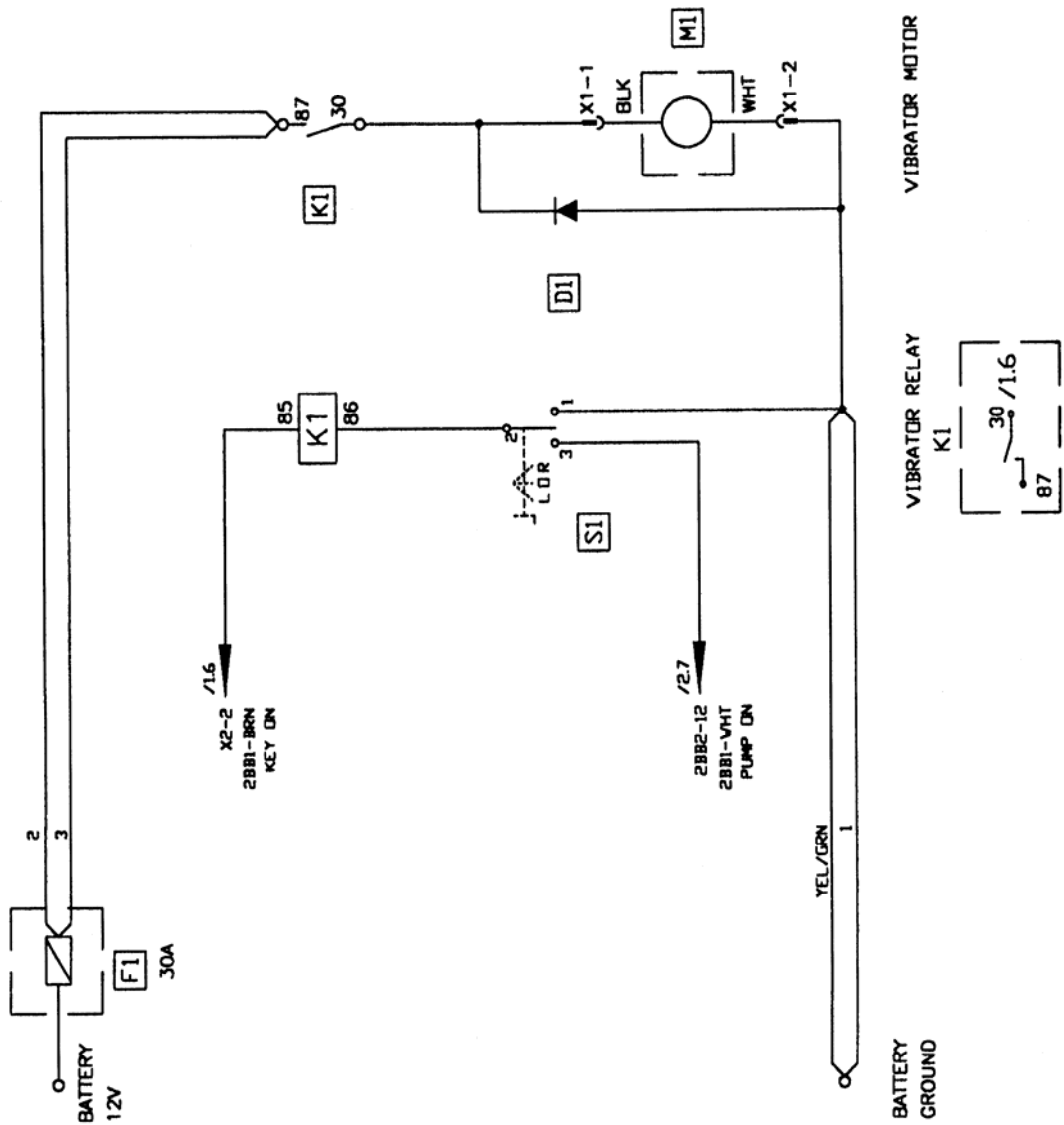

REVISION:



TRAILER MOUNTED PUMP MODEL C50HP
RADIO REMOTE CONTROL OPTION
ELECTRICAL SCHEMATIC

SCMTC

PAGE 17

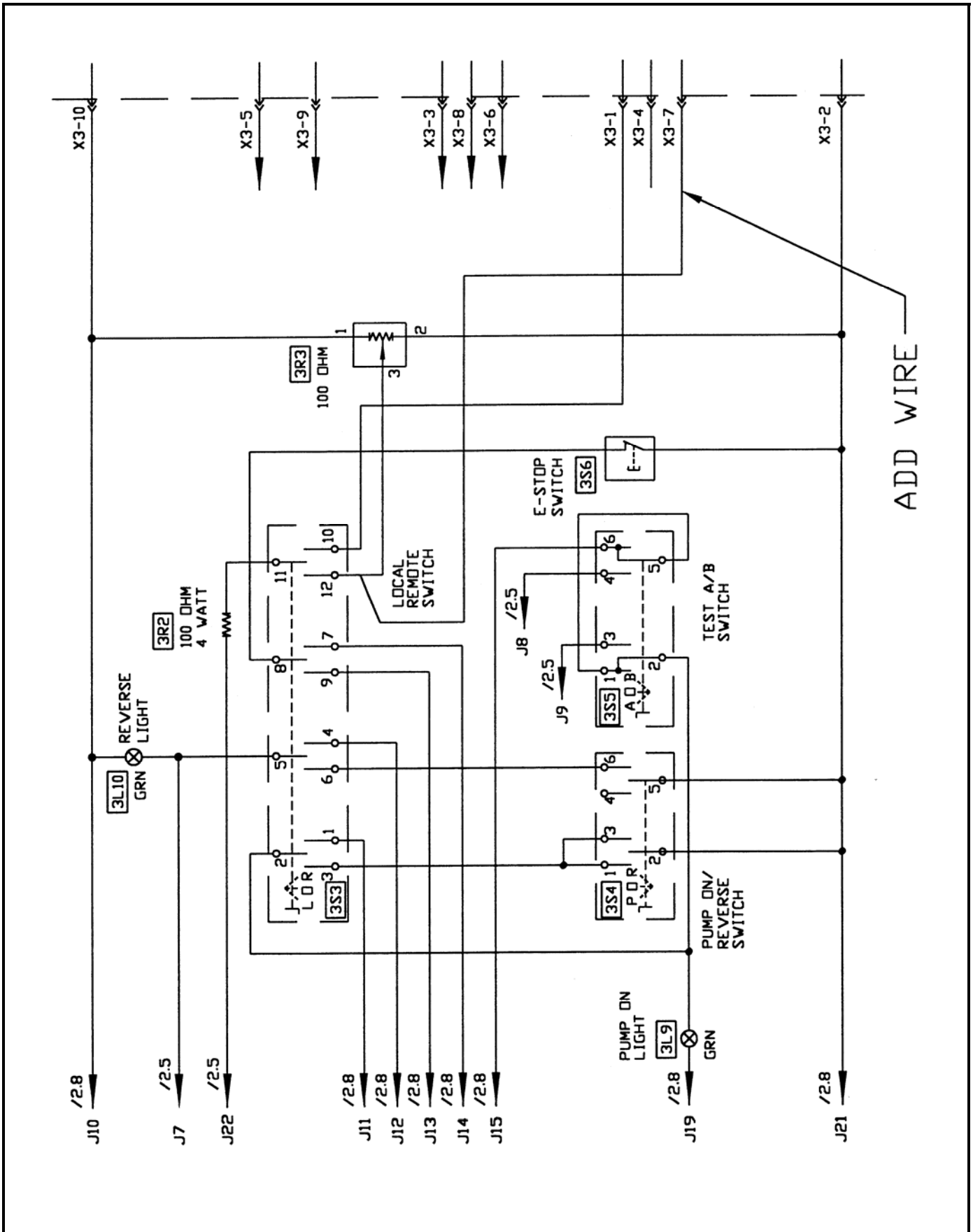

REVISION:



**TRAILER MOUNTED PUMP
MODEL C50HP
HYDRAULIC HOSE KIT**

SCMTC

PAGE 18

No.	Part No.	End #1	End #2
DRIVE CYLINDER CIRCUIT			
H01	85664-002	Tank Suction	Main Pump "S"
H02	85666-003	Main Pump "A"	Cylinder "A"
H03	85666-003	Main Pump "B"	Cylinder "B"
H04	85659-011	Main Pump "M2"	Hot Oil Shuttle "B"
H05	85659-004	Main Pump "M2"	Relief Valve (B) "1"
H06	85659-012	Main Pump "M4"	Relief Valve (B) "2"
H07	85659-004	Main Pump "M1"	Relief Valve (A) "1"
H08	85659-012	Main Pump "M5"	Relief Valve (A) "2"
H09	85659-013	Main Pump "M2"	Shuttle Valve
H10	85659-013	Main Pump "M1"	Shuttle Valve
H11	85654-002	Main Pump "L1"	Tank - 25 psi Check
H12	85654-003	Main Pump "L1"	Oil Cooler "IN"
H13	85654-004	Oil Cooler "OUT"	Tank Return Filter
H14	85659-014	Main Pump "CD"	Hot Oil Shuttle "T"
H15			
H16			
H17	85659-002	Check Loop	
H18	85659-002	Check Loop	
H19	85659-002	Check Loop	
H20	85659-002	Check Loop	
SWING TUBE CIRCUIT			
H21	85663-003	Tank Suction	Tandem Pump "S"
H22	85657-002	Tandem Pump 12 cc	Swing Tube Manifold "P2"
H23	85667-002	Swing Tube Manifold "ACC"	Accumulator
H24	85657-002	Swing Ram Bulkhead "A"	Swing Ram (A)
H25	85657-002	Swing Ram Bulkhead "B"	Swing Ram (B)
H26			
AGITATOR / OUTRIGGER CIRCUIT			
H27	85657-007	Tandem Pump 10 cc	Bulkhead "P" Tee
H28	85657-002	Bulkhead "P" Tee	Bypass Valve "1"
H29	85657-006	Bulkhead "P"	Agitator - O/R Valve "P"
H30	85658-003	Agitator Valve "A"	Agitator Motor "A"
H31	85658-003	Agitator Valve "B"	Agitator Motor "B"
H32	85659-010	O/R Valve "A"	RH Outrigger Bore
H33	85659-010	O/R Valve "B"	RH Outrigger Rod
H34	85659-010	O/R Valve Tube "A"	LH Outrigger Bore
H35	85659-010	O/R Valve Tube "B"	LH Outrigger Rod
H36	85657-002	Agitator - O/R Valve "T"	Bulkhead "T"
H37	85657-002	Bulkhead "T"	Tank Return
FUEL SYSTEM			
	85669-001	Fuel Tank	Fuel Filter "IN"
	85669-003	Fuel Filter "OUT"	Engine
	85669-004	Fuel Tank Crossover	

REVISION: