

Record sheet for regular inspections by the competent inspection personnel

Instpection report No.: Date:

There are – are no – reasons why the machine should not continue to be operated.

Reinspection is – is not – required for

Competent inspector:

.....
(Date, City)

.....
(Name)

.....
(Signature)

Instpection report No.: Date:

There are – are no – reasons why the machine should not continue to be operated.

Reinspection is – is not – required for

Competent inspector:

.....
(Date, City)

.....
(Name)

.....
(Signature)

Instpection report No.: Date:

There are – are no – reasons why the machine should not continue to be operated.

Reinspection is – is not – required for

Competent inspector:

.....
(Date, City)

.....
(Name)

.....
(Signature)

Record sheet for regular inspections by the competent inspection personnel

Instpection report No.: Date:

There are – are no – reasons why the machine should not continue to be operated.

Reinspection is – is not – required for

Competent inspector:

.....
(Date, City)

.....
(Name)

.....
(Signature)

Instpection report No.: Date:

There are – are no – reasons why the machine should not continue to be operated.

Reinspection is – is not – required for

Competent inspector:

.....
(Date, City)

.....
(Name)

.....
(Signature)

Instpection report No.: Date:

There are – are no – reasons why the machine should not continue to be operated.

Reinspection is – is not – required for

Competent inspector:

.....
(Date, City)

.....
(Name)

.....
(Signature)

Record sheet for regular inspections by the competent inspection personnel

Instpection report No.: Date:

There are – are no – reasons why the machine should not continue to be operated.

Reinspection is – is not – required for

Competent inspector:

.....
(Date, City)

.....
(Name)

.....
(Signature)

Instpection report No.: Date:

There are – are no – reasons why the machine should not continue to be operated.

Reinspection is – is not – required for

Competent inspector:

.....
(Date, City)

.....
(Name)

.....
(Signature)

Instpection report No.: Date:

There are – are no – reasons why the machine should not continue to be operated.

Reinspection is – is not – required for

Competent inspector:

.....
(Date, City)

.....
(Name)

.....
(Signature)

Record sheet for regular inspections by the competent inspection personnel

Instpection report No.: Date:

There are – are no – reasons why the machine should not continue to be operated.

Reinspection is – is not – required for

Competent inspector:

.....
(Date, City)

.....
(Name)

.....
(Signature)

Instpection report No.: Date:

There are – are no – reasons why the machine should not continue to be operated.

Reinspection is – is not – required for

Competent inspector:

.....
(Date, City)

.....
(Name)

.....
(Signature)

Instpection report No.: Date:

There are – are no – reasons why the machine should not continue to be operated.

Reinspection is – is not – required for

Competent inspector:

.....
(Date, City)

.....
(Name)

.....
(Signature)

assembly groupes - structuring

with description from the assembly groups and parts respectively

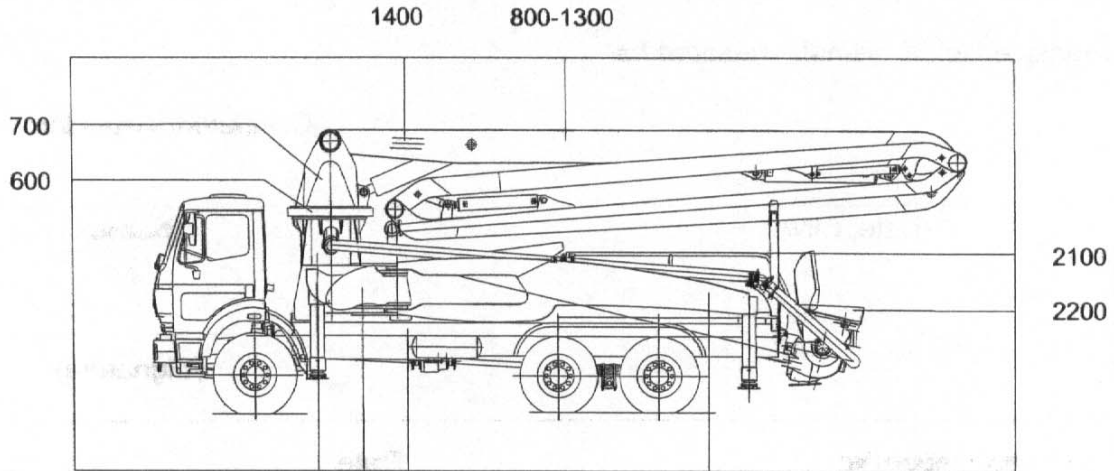

300 / 2700

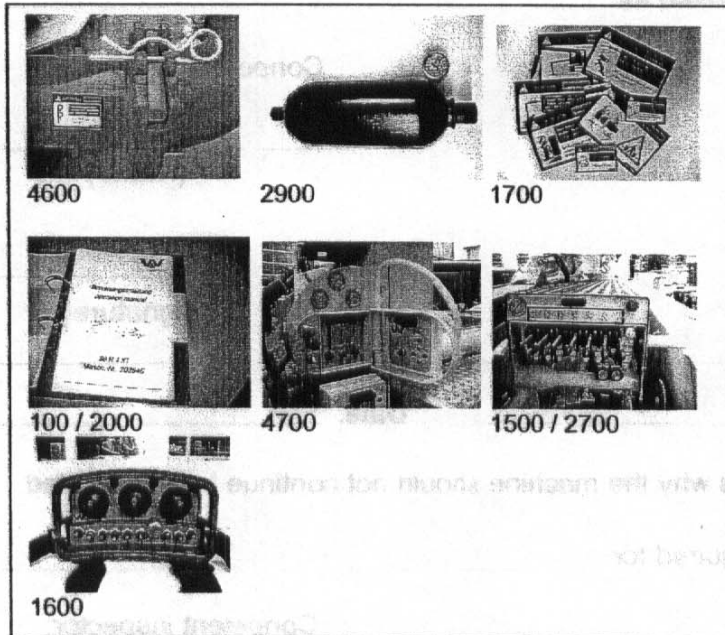

- 1500 hydraulic system and hydraulic valves
- 1600 electric equipment
- 1700 sticker sets

- concrete pump:**
- 2000 documents
 - 2100 drive assembly
 - 2200 gear box
 - 2300 hydraulic pump (main)
 - 2400 oil-tank
 - 2500 drive shaft
 - 2600 fuel equipment
 - 2700 hydraulic control system
 - 2800 oil-cooler
 - 2900 accumulator
 - 3000 central lubrication
 - 3100 hydraulic motor
 - 3200 hydraulic lines
 - 3300 air compressor
 - 3400 control panel
 - 3500 concrete pump
 - 3700 S-valve
 - 3800 hopper
 - 4000 vacuum pump
 - 4100 aggregate
 - 4200 sub frame
 - 4300 water tank
 - 4400 axle
 - 4500 water pump
 - 4600 vibrator
 - 4700 safety guards, equipment
 - 4700 electrical system

- concrete boom:**
- 100 documents
 - 200 sub frame
 - 300 outrigger front R+L
 - 400 outrigger rear L+R
 - 500 pedestal
 - 700 slewing head with ball pivot
 - 700 slewing head with slewing column
 - 800-1300 boom (joint A-E)
 - 1400 concrete delivery line

Inspection report for concrete booms

Inspection report -Nr:	Machine-Nr	Hours of operation:
		Concrete output m ³ :
Company:	Post code:	City:
Boom Type:	Boom Nr.	NL WV

Proof – Result of the Tests

without defects	defects	reinspection required	shut down
<input type="checkbox"/>	<input type="checkbox"/>	<input type="checkbox"/>	<input type="checkbox"/>

Reinspection until date:

Error code:

- | | | | |
|------------------|---------------------|-------------------|--------------------------|
| 00 no objections | 08 corrosion | 16 porous | 24 deformation |
| 01 cracks | 09 lacquer failures | 17 burned through | 25 bear movement |
| 02 broken | 10 fraying | 18 not fixed | 26 lubrication |
| 03 leaky | 11 scratched | 19 clomp | 27 readability |
| 04 no function | 12 bendet | 20 sawing | 28 missing components |
| 05 low lifetime | 13 noises | 21 contaminated | 29 hydraulical |
| 06 worn out | 14 vibration | 22 bad contact | 30 electrical |
| 07 dirt | 15 miscellaneous | 23 temperature | 31 reinspection required |

<p>100 documents</p> <p>101 instruction manual <input type="checkbox"/> <input type="checkbox"/> <input type="checkbox"/> <input type="checkbox"/> <input type="checkbox"/> <input type="checkbox"/></p> <p>102 spare parts list <input type="checkbox"/> <input type="checkbox"/> <input type="checkbox"/> <input type="checkbox"/> <input type="checkbox"/> <input type="checkbox"/></p> <p>200 sub frame</p> <p>201 frame connection cpl. <input type="checkbox"/> <input type="checkbox"/> <input type="checkbox"/> <input type="checkbox"/> <input type="checkbox"/> <input type="checkbox"/></p> <p>300 outrigger front R+L</p> <p>301 transportation safety device <input type="checkbox"/> <input type="checkbox"/> <input type="checkbox"/> <input type="checkbox"/> <input type="checkbox"/> <input type="checkbox"/></p> <p>302 outrigger <input type="checkbox"/> <input type="checkbox"/> <input type="checkbox"/> <input type="checkbox"/> <input type="checkbox"/> <input type="checkbox"/></p> <p>303 extension box <input type="checkbox"/> <input type="checkbox"/> <input type="checkbox"/> <input type="checkbox"/> <input type="checkbox"/> <input type="checkbox"/></p> <p>304 locking device <input type="checkbox"/> <input type="checkbox"/> <input type="checkbox"/> <input type="checkbox"/> <input type="checkbox"/> <input type="checkbox"/></p> <p>305 slewing bearing <input type="checkbox"/> <input type="checkbox"/> <input type="checkbox"/> <input type="checkbox"/> <input type="checkbox"/> <input type="checkbox"/></p> <p>306 tum locking device <input type="checkbox"/> <input type="checkbox"/> <input type="checkbox"/> <input type="checkbox"/> <input type="checkbox"/> <input type="checkbox"/></p> <p>307 support safeguard <input type="checkbox"/> <input type="checkbox"/> <input type="checkbox"/> <input type="checkbox"/> <input type="checkbox"/> <input type="checkbox"/></p> <p>308 support plate <input type="checkbox"/> <input type="checkbox"/> <input type="checkbox"/> <input type="checkbox"/> <input type="checkbox"/> <input type="checkbox"/></p> <p>309 fixing of jack cylinder <input type="checkbox"/> <input type="checkbox"/> <input type="checkbox"/> <input type="checkbox"/> <input type="checkbox"/> <input type="checkbox"/></p> <p>310 jack cylinder <input type="checkbox"/> <input type="checkbox"/> <input type="checkbox"/> <input type="checkbox"/> <input type="checkbox"/> <input type="checkbox"/></p>	<p>311 swing cylinder <input type="checkbox"/> <input type="checkbox"/> <input type="checkbox"/> <input type="checkbox"/> <input type="checkbox"/> <input type="checkbox"/></p> <p>312 telescopic-cylinder <input type="checkbox"/> <input type="checkbox"/> <input type="checkbox"/> <input type="checkbox"/> <input type="checkbox"/> <input type="checkbox"/></p> <p>313 pressure adjustment <input type="checkbox"/> <input type="checkbox"/> <input type="checkbox"/> <input type="checkbox"/> <input type="checkbox"/> <input type="checkbox"/></p> <p>400 outrigger rear L+R</p> <p>401 transportation safety device <input type="checkbox"/> <input type="checkbox"/> <input type="checkbox"/> <input type="checkbox"/> <input type="checkbox"/> <input type="checkbox"/></p> <p>402 outrigger <input type="checkbox"/> <input type="checkbox"/> <input type="checkbox"/> <input type="checkbox"/> <input type="checkbox"/> <input type="checkbox"/></p> <p>403 extension box <input type="checkbox"/> <input type="checkbox"/> <input type="checkbox"/> <input type="checkbox"/> <input type="checkbox"/> <input type="checkbox"/></p> <p>405 locking device <input type="checkbox"/> <input type="checkbox"/> <input type="checkbox"/> <input type="checkbox"/> <input type="checkbox"/> <input type="checkbox"/></p> <p>Notes:</p> <hr/> <hr/> <hr/> <hr/> <hr/>
---	--

Inspection report for concrete booms

Inspection report Nr: _____ Boom type: _____ Machine-Nr: _____

Error code:			
00 no objections	08 corrosion	16 porous	24 deformation
01 cracks	09 lacquer failures	17 burned through	25 bear movement
02 broken	10 fraying	18 not fixed	26 lubrication
03 leaky	11 scratched	19 clump	27 readability
04 no function	12 bendet	20 sawing	28 missing components
05 low lifetime	13 noises	21 contaminated	29 hydraulical
06 worn out	14 vibration	22 bad contact	30 electrical
07 dirt	15 miscellaneous	23 temperature	31 reinspection required

<table border="0" style="width: 100%;"> <tr> <td style="width: 30%;">406 slewing bearing</td> <td style="width: 20%;"><input type="checkbox"/></td><td><input type="checkbox"/></td><td><input type="checkbox"/></td><td><input type="checkbox"/></td><td><input type="checkbox"/></td> </tr> <tr> <td>407 turn locking device</td> <td><input type="checkbox"/></td><td><input type="checkbox"/></td><td><input type="checkbox"/></td><td><input type="checkbox"/></td><td><input type="checkbox"/></td> </tr> <tr> <td>408 support safeguard</td> <td><input type="checkbox"/></td><td><input type="checkbox"/></td><td><input type="checkbox"/></td><td><input type="checkbox"/></td><td><input type="checkbox"/></td> </tr> <tr> <td>409 support plate</td> <td><input type="checkbox"/></td><td><input type="checkbox"/></td><td><input type="checkbox"/></td><td><input type="checkbox"/></td><td><input type="checkbox"/></td> </tr> <tr> <td>410 fixing of jack cylinder</td> <td><input type="checkbox"/></td><td><input type="checkbox"/></td><td><input type="checkbox"/></td><td><input type="checkbox"/></td><td><input type="checkbox"/></td> </tr> <tr> <td>411 jack cylinder</td> <td><input type="checkbox"/></td><td><input type="checkbox"/></td><td><input type="checkbox"/></td><td><input type="checkbox"/></td><td><input type="checkbox"/></td> </tr> <tr> <td>412 swing cylinder</td> <td><input type="checkbox"/></td><td><input type="checkbox"/></td><td><input type="checkbox"/></td><td><input type="checkbox"/></td><td><input type="checkbox"/></td> </tr> <tr> <td>413 telescopic cylinder</td> <td><input type="checkbox"/></td><td><input type="checkbox"/></td><td><input type="checkbox"/></td><td><input type="checkbox"/></td><td><input type="checkbox"/></td> </tr> <tr> <td colspan="6">500 pedestal</td> </tr> <tr> <td>501 pedestal mounting</td> <td><input type="checkbox"/></td><td><input type="checkbox"/></td><td><input type="checkbox"/></td><td><input type="checkbox"/></td><td><input type="checkbox"/></td> </tr> <tr> <td>502 sub frame</td> <td><input type="checkbox"/></td><td><input type="checkbox"/></td><td><input type="checkbox"/></td><td><input type="checkbox"/></td><td><input type="checkbox"/></td> </tr> <tr> <td>503 truck frame</td> <td><input type="checkbox"/></td><td><input type="checkbox"/></td><td><input type="checkbox"/></td><td><input type="checkbox"/></td><td><input type="checkbox"/></td> </tr> <tr> <td>504 pedestal (structure)</td> <td><input type="checkbox"/></td><td><input type="checkbox"/></td><td><input type="checkbox"/></td><td><input type="checkbox"/></td><td><input type="checkbox"/></td> </tr> <tr> <td>505 boom valve without leaking</td> <td><input type="checkbox"/></td><td><input type="checkbox"/></td><td><input type="checkbox"/></td><td><input type="checkbox"/></td><td><input type="checkbox"/></td> </tr> <tr> <td>506 boom rest</td> <td><input type="checkbox"/></td><td><input type="checkbox"/></td><td><input type="checkbox"/></td><td><input type="checkbox"/></td><td><input type="checkbox"/></td> </tr> <tr> <td>507 transportation safety device</td> <td><input type="checkbox"/></td><td><input type="checkbox"/></td><td><input type="checkbox"/></td><td><input type="checkbox"/></td><td><input type="checkbox"/></td> </tr> <tr> <td>508 hydraulic line</td> <td><input type="checkbox"/></td><td><input type="checkbox"/></td><td><input type="checkbox"/></td><td><input type="checkbox"/></td><td><input type="checkbox"/></td> </tr> <tr> <td colspan="6">600 slewing head with ball pivot</td> </tr> <tr> <td>601 slewing head</td> <td><input type="checkbox"/></td><td><input type="checkbox"/></td><td><input type="checkbox"/></td><td><input type="checkbox"/></td><td><input type="checkbox"/></td> </tr> <tr> <td>602 ball pivot ring</td> <td><input type="checkbox"/></td><td><input type="checkbox"/></td><td><input type="checkbox"/></td><td><input type="checkbox"/></td><td><input type="checkbox"/></td> </tr> <tr> <td>603 mounting ball pivot ring</td> <td><input type="checkbox"/></td><td><input type="checkbox"/></td><td><input type="checkbox"/></td><td><input type="checkbox"/></td><td><input type="checkbox"/></td> </tr> <tr> <td>604 drive pinion</td> <td><input type="checkbox"/></td><td><input type="checkbox"/></td><td><input type="checkbox"/></td><td><input type="checkbox"/></td><td><input type="checkbox"/></td> </tr> </table>	406 slewing bearing	<input type="checkbox"/>	<input type="checkbox"/>	<input type="checkbox"/>	<input type="checkbox"/>	<input type="checkbox"/>	407 turn locking device	<input type="checkbox"/>	<input type="checkbox"/>	<input type="checkbox"/>	<input type="checkbox"/>	<input type="checkbox"/>	408 support safeguard	<input type="checkbox"/>	<input type="checkbox"/>	<input type="checkbox"/>	<input type="checkbox"/>	<input type="checkbox"/>	409 support plate	<input type="checkbox"/>	<input type="checkbox"/>	<input type="checkbox"/>	<input type="checkbox"/>	<input type="checkbox"/>	410 fixing of jack cylinder	<input type="checkbox"/>	<input type="checkbox"/>	<input type="checkbox"/>	<input type="checkbox"/>	<input type="checkbox"/>	411 jack cylinder	<input type="checkbox"/>	<input type="checkbox"/>	<input type="checkbox"/>	<input type="checkbox"/>	<input type="checkbox"/>	412 swing cylinder	<input type="checkbox"/>	<input type="checkbox"/>	<input type="checkbox"/>	<input type="checkbox"/>	<input type="checkbox"/>	413 telescopic cylinder	<input type="checkbox"/>	<input type="checkbox"/>	<input type="checkbox"/>	<input type="checkbox"/>	<input type="checkbox"/>	500 pedestal						501 pedestal mounting	<input type="checkbox"/>	<input type="checkbox"/>	<input type="checkbox"/>	<input type="checkbox"/>	<input type="checkbox"/>	502 sub frame	<input type="checkbox"/>	<input type="checkbox"/>	<input type="checkbox"/>	<input type="checkbox"/>	<input type="checkbox"/>	503 truck frame	<input type="checkbox"/>	<input type="checkbox"/>	<input type="checkbox"/>	<input type="checkbox"/>	<input type="checkbox"/>	504 pedestal (structure)	<input type="checkbox"/>	<input type="checkbox"/>	<input type="checkbox"/>	<input type="checkbox"/>	<input type="checkbox"/>	505 boom valve without leaking	<input type="checkbox"/>	<input type="checkbox"/>	<input type="checkbox"/>	<input type="checkbox"/>	<input type="checkbox"/>	506 boom rest	<input type="checkbox"/>	<input type="checkbox"/>	<input type="checkbox"/>	<input type="checkbox"/>	<input type="checkbox"/>	507 transportation safety device	<input type="checkbox"/>	<input type="checkbox"/>	<input type="checkbox"/>	<input type="checkbox"/>	<input type="checkbox"/>	508 hydraulic line	<input type="checkbox"/>	<input type="checkbox"/>	<input type="checkbox"/>	<input type="checkbox"/>	<input type="checkbox"/>	600 slewing head with ball pivot						601 slewing head	<input type="checkbox"/>	<input type="checkbox"/>	<input type="checkbox"/>	<input type="checkbox"/>	<input type="checkbox"/>	602 ball pivot ring	<input type="checkbox"/>	<input type="checkbox"/>	<input type="checkbox"/>	<input type="checkbox"/>	<input type="checkbox"/>	603 mounting ball pivot ring	<input type="checkbox"/>	<input type="checkbox"/>	<input type="checkbox"/>	<input type="checkbox"/>	<input type="checkbox"/>	604 drive pinion	<input type="checkbox"/>	<input type="checkbox"/>	<input type="checkbox"/>	<input type="checkbox"/>	<input type="checkbox"/>	<table border="0" style="width: 100%;"> <tr> <td style="width: 30%;">605 slewing drive mounting</td> <td style="width: 20%;"><input type="checkbox"/></td><td><input type="checkbox"/></td><td><input type="checkbox"/></td><td><input type="checkbox"/></td><td><input type="checkbox"/></td> </tr> <tr> <td>606 slewing stop device</td> <td><input type="checkbox"/></td><td><input type="checkbox"/></td><td><input type="checkbox"/></td><td><input type="checkbox"/></td><td><input type="checkbox"/></td> </tr> <tr> <td>607 slewing drive (tooth backlash)</td> <td><input type="checkbox"/></td><td><input type="checkbox"/></td><td><input type="checkbox"/></td><td><input type="checkbox"/></td><td><input type="checkbox"/></td> </tr> <tr> <td>608 slewing drive</td> <td><input type="checkbox"/></td><td><input type="checkbox"/></td><td><input type="checkbox"/></td><td><input type="checkbox"/></td><td><input type="checkbox"/></td> </tr> <tr> <td>609 brake function</td> <td><input type="checkbox"/></td><td><input type="checkbox"/></td><td><input type="checkbox"/></td><td><input type="checkbox"/></td><td><input type="checkbox"/></td> </tr> <tr> <td>610 speed</td> <td><input type="checkbox"/></td><td><input type="checkbox"/></td><td><input type="checkbox"/></td><td><input type="checkbox"/></td><td><input type="checkbox"/></td> </tr> <tr> <td>611 pressure setting</td> <td><input type="checkbox"/></td><td><input type="checkbox"/></td><td><input type="checkbox"/></td><td><input type="checkbox"/></td><td><input type="checkbox"/></td> </tr> <tr> <td>612 hydraulic lines</td> <td><input type="checkbox"/></td><td><input type="checkbox"/></td><td><input type="checkbox"/></td><td><input type="checkbox"/></td><td><input type="checkbox"/></td> </tr> <tr> <td colspan="6">700 slewing head with slewing column</td> </tr> <tr> <td>701 slewing head</td> <td><input type="checkbox"/></td><td><input type="checkbox"/></td><td><input type="checkbox"/></td><td><input type="checkbox"/></td><td><input type="checkbox"/></td> </tr> <tr> <td>702 slewing column bearing</td> <td><input type="checkbox"/></td><td><input type="checkbox"/></td><td><input type="checkbox"/></td><td><input type="checkbox"/></td><td><input type="checkbox"/></td> </tr> <tr> <td>703 slewing drive (tooth backlash)</td> <td><input type="checkbox"/></td><td><input type="checkbox"/></td><td><input type="checkbox"/></td><td><input type="checkbox"/></td><td><input type="checkbox"/></td> </tr> <tr> <td>704 speed</td> <td><input type="checkbox"/></td><td><input type="checkbox"/></td><td><input type="checkbox"/></td><td><input type="checkbox"/></td><td><input type="checkbox"/></td> </tr> <tr> <td>705 pressure settings</td> <td><input type="checkbox"/></td><td><input type="checkbox"/></td><td><input type="checkbox"/></td><td><input type="checkbox"/></td><td><input type="checkbox"/></td> </tr> <tr> <td>706 hydraulic lines</td> <td><input type="checkbox"/></td><td><input type="checkbox"/></td><td><input type="checkbox"/></td><td><input type="checkbox"/></td><td><input type="checkbox"/></td> </tr> <tr> <td>707 swivel cylinder</td> <td><input type="checkbox"/></td><td><input type="checkbox"/></td><td><input type="checkbox"/></td><td><input type="checkbox"/></td><td><input type="checkbox"/></td> </tr> </table> <p>Notes:</p> <hr/> <hr/> <hr/> <hr/>	605 slewing drive mounting	<input type="checkbox"/>	<input type="checkbox"/>	<input type="checkbox"/>	<input type="checkbox"/>	<input type="checkbox"/>	606 slewing stop device	<input type="checkbox"/>	<input type="checkbox"/>	<input type="checkbox"/>	<input type="checkbox"/>	<input type="checkbox"/>	607 slewing drive (tooth backlash)	<input type="checkbox"/>	<input type="checkbox"/>	<input type="checkbox"/>	<input type="checkbox"/>	<input type="checkbox"/>	608 slewing drive	<input type="checkbox"/>	<input type="checkbox"/>	<input type="checkbox"/>	<input type="checkbox"/>	<input type="checkbox"/>	609 brake function	<input type="checkbox"/>	<input type="checkbox"/>	<input type="checkbox"/>	<input type="checkbox"/>	<input type="checkbox"/>	610 speed	<input type="checkbox"/>	<input type="checkbox"/>	<input type="checkbox"/>	<input type="checkbox"/>	<input type="checkbox"/>	611 pressure setting	<input type="checkbox"/>	<input type="checkbox"/>	<input type="checkbox"/>	<input type="checkbox"/>	<input type="checkbox"/>	612 hydraulic lines	<input type="checkbox"/>	<input type="checkbox"/>	<input type="checkbox"/>	<input type="checkbox"/>	<input type="checkbox"/>	700 slewing head with slewing column						701 slewing head	<input type="checkbox"/>	<input type="checkbox"/>	<input type="checkbox"/>	<input type="checkbox"/>	<input type="checkbox"/>	702 slewing column bearing	<input type="checkbox"/>	<input type="checkbox"/>	<input type="checkbox"/>	<input type="checkbox"/>	<input type="checkbox"/>	703 slewing drive (tooth backlash)	<input type="checkbox"/>	<input type="checkbox"/>	<input type="checkbox"/>	<input type="checkbox"/>	<input type="checkbox"/>	704 speed	<input type="checkbox"/>	<input type="checkbox"/>	<input type="checkbox"/>	<input type="checkbox"/>	<input type="checkbox"/>	705 pressure settings	<input type="checkbox"/>	<input type="checkbox"/>	<input type="checkbox"/>	<input type="checkbox"/>	<input type="checkbox"/>	706 hydraulic lines	<input type="checkbox"/>	<input type="checkbox"/>	<input type="checkbox"/>	<input type="checkbox"/>	<input type="checkbox"/>	707 swivel cylinder	<input type="checkbox"/>	<input type="checkbox"/>	<input type="checkbox"/>	<input type="checkbox"/>	<input type="checkbox"/>
406 slewing bearing	<input type="checkbox"/>	<input type="checkbox"/>	<input type="checkbox"/>	<input type="checkbox"/>	<input type="checkbox"/>																																																																																																																																																																																																																																
407 turn locking device	<input type="checkbox"/>	<input type="checkbox"/>	<input type="checkbox"/>	<input type="checkbox"/>	<input type="checkbox"/>																																																																																																																																																																																																																																
408 support safeguard	<input type="checkbox"/>	<input type="checkbox"/>	<input type="checkbox"/>	<input type="checkbox"/>	<input type="checkbox"/>																																																																																																																																																																																																																																
409 support plate	<input type="checkbox"/>	<input type="checkbox"/>	<input type="checkbox"/>	<input type="checkbox"/>	<input type="checkbox"/>																																																																																																																																																																																																																																
410 fixing of jack cylinder	<input type="checkbox"/>	<input type="checkbox"/>	<input type="checkbox"/>	<input type="checkbox"/>	<input type="checkbox"/>																																																																																																																																																																																																																																
411 jack cylinder	<input type="checkbox"/>	<input type="checkbox"/>	<input type="checkbox"/>	<input type="checkbox"/>	<input type="checkbox"/>																																																																																																																																																																																																																																
412 swing cylinder	<input type="checkbox"/>	<input type="checkbox"/>	<input type="checkbox"/>	<input type="checkbox"/>	<input type="checkbox"/>																																																																																																																																																																																																																																
413 telescopic cylinder	<input type="checkbox"/>	<input type="checkbox"/>	<input type="checkbox"/>	<input type="checkbox"/>	<input type="checkbox"/>																																																																																																																																																																																																																																
500 pedestal																																																																																																																																																																																																																																					
501 pedestal mounting	<input type="checkbox"/>	<input type="checkbox"/>	<input type="checkbox"/>	<input type="checkbox"/>	<input type="checkbox"/>																																																																																																																																																																																																																																
502 sub frame	<input type="checkbox"/>	<input type="checkbox"/>	<input type="checkbox"/>	<input type="checkbox"/>	<input type="checkbox"/>																																																																																																																																																																																																																																
503 truck frame	<input type="checkbox"/>	<input type="checkbox"/>	<input type="checkbox"/>	<input type="checkbox"/>	<input type="checkbox"/>																																																																																																																																																																																																																																
504 pedestal (structure)	<input type="checkbox"/>	<input type="checkbox"/>	<input type="checkbox"/>	<input type="checkbox"/>	<input type="checkbox"/>																																																																																																																																																																																																																																
505 boom valve without leaking	<input type="checkbox"/>	<input type="checkbox"/>	<input type="checkbox"/>	<input type="checkbox"/>	<input type="checkbox"/>																																																																																																																																																																																																																																
506 boom rest	<input type="checkbox"/>	<input type="checkbox"/>	<input type="checkbox"/>	<input type="checkbox"/>	<input type="checkbox"/>																																																																																																																																																																																																																																
507 transportation safety device	<input type="checkbox"/>	<input type="checkbox"/>	<input type="checkbox"/>	<input type="checkbox"/>	<input type="checkbox"/>																																																																																																																																																																																																																																
508 hydraulic line	<input type="checkbox"/>	<input type="checkbox"/>	<input type="checkbox"/>	<input type="checkbox"/>	<input type="checkbox"/>																																																																																																																																																																																																																																
600 slewing head with ball pivot																																																																																																																																																																																																																																					
601 slewing head	<input type="checkbox"/>	<input type="checkbox"/>	<input type="checkbox"/>	<input type="checkbox"/>	<input type="checkbox"/>																																																																																																																																																																																																																																
602 ball pivot ring	<input type="checkbox"/>	<input type="checkbox"/>	<input type="checkbox"/>	<input type="checkbox"/>	<input type="checkbox"/>																																																																																																																																																																																																																																
603 mounting ball pivot ring	<input type="checkbox"/>	<input type="checkbox"/>	<input type="checkbox"/>	<input type="checkbox"/>	<input type="checkbox"/>																																																																																																																																																																																																																																
604 drive pinion	<input type="checkbox"/>	<input type="checkbox"/>	<input type="checkbox"/>	<input type="checkbox"/>	<input type="checkbox"/>																																																																																																																																																																																																																																
605 slewing drive mounting	<input type="checkbox"/>	<input type="checkbox"/>	<input type="checkbox"/>	<input type="checkbox"/>	<input type="checkbox"/>																																																																																																																																																																																																																																
606 slewing stop device	<input type="checkbox"/>	<input type="checkbox"/>	<input type="checkbox"/>	<input type="checkbox"/>	<input type="checkbox"/>																																																																																																																																																																																																																																
607 slewing drive (tooth backlash)	<input type="checkbox"/>	<input type="checkbox"/>	<input type="checkbox"/>	<input type="checkbox"/>	<input type="checkbox"/>																																																																																																																																																																																																																																
608 slewing drive	<input type="checkbox"/>	<input type="checkbox"/>	<input type="checkbox"/>	<input type="checkbox"/>	<input type="checkbox"/>																																																																																																																																																																																																																																
609 brake function	<input type="checkbox"/>	<input type="checkbox"/>	<input type="checkbox"/>	<input type="checkbox"/>	<input type="checkbox"/>																																																																																																																																																																																																																																
610 speed	<input type="checkbox"/>	<input type="checkbox"/>	<input type="checkbox"/>	<input type="checkbox"/>	<input type="checkbox"/>																																																																																																																																																																																																																																
611 pressure setting	<input type="checkbox"/>	<input type="checkbox"/>	<input type="checkbox"/>	<input type="checkbox"/>	<input type="checkbox"/>																																																																																																																																																																																																																																
612 hydraulic lines	<input type="checkbox"/>	<input type="checkbox"/>	<input type="checkbox"/>	<input type="checkbox"/>	<input type="checkbox"/>																																																																																																																																																																																																																																
700 slewing head with slewing column																																																																																																																																																																																																																																					
701 slewing head	<input type="checkbox"/>	<input type="checkbox"/>	<input type="checkbox"/>	<input type="checkbox"/>	<input type="checkbox"/>																																																																																																																																																																																																																																
702 slewing column bearing	<input type="checkbox"/>	<input type="checkbox"/>	<input type="checkbox"/>	<input type="checkbox"/>	<input type="checkbox"/>																																																																																																																																																																																																																																
703 slewing drive (tooth backlash)	<input type="checkbox"/>	<input type="checkbox"/>	<input type="checkbox"/>	<input type="checkbox"/>	<input type="checkbox"/>																																																																																																																																																																																																																																
704 speed	<input type="checkbox"/>	<input type="checkbox"/>	<input type="checkbox"/>	<input type="checkbox"/>	<input type="checkbox"/>																																																																																																																																																																																																																																
705 pressure settings	<input type="checkbox"/>	<input type="checkbox"/>	<input type="checkbox"/>	<input type="checkbox"/>	<input type="checkbox"/>																																																																																																																																																																																																																																
706 hydraulic lines	<input type="checkbox"/>	<input type="checkbox"/>	<input type="checkbox"/>	<input type="checkbox"/>	<input type="checkbox"/>																																																																																																																																																																																																																																
707 swivel cylinder	<input type="checkbox"/>	<input type="checkbox"/>	<input type="checkbox"/>	<input type="checkbox"/>	<input type="checkbox"/>																																																																																																																																																																																																																																

Inspection report for concrete booms

Inspection report Nr: _____ Boom type: _____ Machine-Nr: _____

Error code:

- | | | | |
|------------------|---------------------|-------------------|--------------------------|
| 00 no objections | 08 corrosion | 16 porous | 24 deformation |
| 01 cracks | 09 lacquer failures | 17 burned through | 25 bear movement |
| 02 broken | 10 fraying | 18 not fixed | 26 lubrication |
| 03 leaky | 11 scratched | 19 clomp | 27 readability |
| 04 no function | 12 bendet | 20 sawing | 28 missing components |
| 05 low lifetime | 13 noises | 21 contaminated | 29 hydraulical |
| 06 worn out | 14 vibration | 22 bad contact | 30 electrical |
| 07 dirt | 15 miscellaneous | 23 temperature | 31 reinspection required |

<p>800 boom <input type="checkbox"/> <input type="checkbox"/> <input type="checkbox"/> <input type="checkbox"/> <input type="checkbox"/></p> <p>801 „Arm1“ <input type="checkbox"/> <input type="checkbox"/> <input type="checkbox"/> <input type="checkbox"/> <input type="checkbox"/></p> <p>802 bracket conveying line <input type="checkbox"/> <input type="checkbox"/> <input type="checkbox"/> <input type="checkbox"/> <input type="checkbox"/></p> <p>803 Drop hook <input type="checkbox"/> <input type="checkbox"/> <input type="checkbox"/> <input type="checkbox"/> <input type="checkbox"/></p> <p>804 „Arm 2“ <input type="checkbox"/> <input type="checkbox"/> <input type="checkbox"/> <input type="checkbox"/> <input type="checkbox"/></p> <p>805 bracket conveying line <input type="checkbox"/> <input type="checkbox"/> <input type="checkbox"/> <input type="checkbox"/> <input type="checkbox"/></p> <p>806 Drop hook <input type="checkbox"/> <input type="checkbox"/> <input type="checkbox"/> <input type="checkbox"/> <input type="checkbox"/></p> <p>807 „Arm 3“ <input type="checkbox"/> <input type="checkbox"/> <input type="checkbox"/> <input type="checkbox"/> <input type="checkbox"/></p> <p>808 bracket conveying line <input type="checkbox"/> <input type="checkbox"/> <input type="checkbox"/> <input type="checkbox"/> <input type="checkbox"/></p> <p>809 guidance and interlock of the arm <input type="checkbox"/> <input type="checkbox"/> <input type="checkbox"/> <input type="checkbox"/> <input type="checkbox"/></p> <p>810 „Arm 4“ <input type="checkbox"/> <input type="checkbox"/> <input type="checkbox"/> <input type="checkbox"/> <input type="checkbox"/></p> <p>811 bracket conveying line <input type="checkbox"/> <input type="checkbox"/> <input type="checkbox"/> <input type="checkbox"/> <input type="checkbox"/></p> <p>812 guidance and interlock of the arm <input type="checkbox"/> <input type="checkbox"/> <input type="checkbox"/> <input type="checkbox"/> <input type="checkbox"/></p> <p>813 „Arm 5“ <input type="checkbox"/> <input type="checkbox"/> <input type="checkbox"/> <input type="checkbox"/> <input type="checkbox"/></p> <p>814 bracket conveying line <input type="checkbox"/> <input type="checkbox"/> <input type="checkbox"/> <input type="checkbox"/> <input type="checkbox"/></p> <p>815 guidance and interlock of the arm <input type="checkbox"/> <input type="checkbox"/> <input type="checkbox"/> <input type="checkbox"/> <input type="checkbox"/></p> <p>900 joint „A“ <input type="checkbox"/> <input type="checkbox"/> <input type="checkbox"/> <input type="checkbox"/> <input type="checkbox"/></p> <p>901 boom <input type="checkbox"/> <input type="checkbox"/> <input type="checkbox"/> <input type="checkbox"/> <input type="checkbox"/></p> <p>902 link lever <input type="checkbox"/> <input type="checkbox"/> <input type="checkbox"/> <input type="checkbox"/> <input type="checkbox"/></p> <p>903 forcing rod <input type="checkbox"/> <input type="checkbox"/> <input type="checkbox"/> <input type="checkbox"/> <input type="checkbox"/></p> <p>904 pin <input type="checkbox"/> <input type="checkbox"/> <input type="checkbox"/> <input type="checkbox"/> <input type="checkbox"/></p> <p>905 cylinder <input type="checkbox"/> <input type="checkbox"/> <input type="checkbox"/> <input type="checkbox"/> <input type="checkbox"/></p>	<p>906 boom speed <input type="checkbox"/> <input type="checkbox"/> <input type="checkbox"/> <input type="checkbox"/> <input type="checkbox"/></p> <p>907 pressure settings <input type="checkbox"/> <input type="checkbox"/> <input type="checkbox"/> <input type="checkbox"/> <input type="checkbox"/></p> <p>908 hydraulic lines <input type="checkbox"/> <input type="checkbox"/> <input type="checkbox"/> <input type="checkbox"/> <input type="checkbox"/></p> <p>909 load holding valve (piston side) <input type="checkbox"/> <input type="checkbox"/> <input type="checkbox"/> <input type="checkbox"/> <input type="checkbox"/></p> <p>910 load holding valve (rod side) <input type="checkbox"/> <input type="checkbox"/> <input type="checkbox"/> <input type="checkbox"/> <input type="checkbox"/></p> <p>1000 joint „B“</p> <p>1001 boom <input type="checkbox"/> <input type="checkbox"/> <input type="checkbox"/> <input type="checkbox"/> <input type="checkbox"/></p> <p>1002 link lever <input type="checkbox"/> <input type="checkbox"/> <input type="checkbox"/> <input type="checkbox"/> <input type="checkbox"/></p> <p>1003 forcing rod <input type="checkbox"/> <input type="checkbox"/> <input type="checkbox"/> <input type="checkbox"/> <input type="checkbox"/></p> <p>1004 pin <input type="checkbox"/> <input type="checkbox"/> <input type="checkbox"/> <input type="checkbox"/> <input type="checkbox"/></p> <p>1005 cylinder <input type="checkbox"/> <input type="checkbox"/> <input type="checkbox"/> <input type="checkbox"/> <input type="checkbox"/></p> <p>1006 boom speed <input type="checkbox"/> <input type="checkbox"/> <input type="checkbox"/> <input type="checkbox"/> <input type="checkbox"/></p> <p>1007 pressure settings <input type="checkbox"/> <input type="checkbox"/> <input type="checkbox"/> <input type="checkbox"/> <input type="checkbox"/></p> <p>1008 hydraulic lines <input type="checkbox"/> <input type="checkbox"/> <input type="checkbox"/> <input type="checkbox"/> <input type="checkbox"/></p> <p>1009 load holding valve (piston side) <input type="checkbox"/> <input type="checkbox"/> <input type="checkbox"/> <input type="checkbox"/> <input type="checkbox"/></p> <p>1010 load holding valve (rod side) <input type="checkbox"/> <input type="checkbox"/> <input type="checkbox"/> <input type="checkbox"/> <input type="checkbox"/></p> <p>Notes:</p> <hr/> <hr/> <hr/> <hr/>
--	--

Inspection report for concrete booms

Inspection report Nr: _____ Boom type: _____ Machine-Nr: _____

Error code:

00 no objections	08 corrosion	16 porous	24 deformation
01 cracks	09 lacquer failures	17 burned through	25 bear movement
02 broken	10 fraying	18 not fixed	26 lubrication
03 leaky	11 scratched	19 clomp	27 readability
04 no function	12 bendet	20 sawing	28 missing components
05 low lifetime	13 noises	21 contaminated	29 hydraulic
06 worn out	14 vibration	22 bad contact	30 electrical
07 dirt	15 miscellaneous	23 temperature	31 reinspection required

1100 joint "C"

1101 boom	<input type="checkbox"/>	<input type="checkbox"/>	<input type="checkbox"/>	<input type="checkbox"/>	<input type="checkbox"/>
1102 link lever	<input type="checkbox"/>	<input type="checkbox"/>	<input type="checkbox"/>	<input type="checkbox"/>	<input type="checkbox"/>
1103 forcing rod	<input type="checkbox"/>	<input type="checkbox"/>	<input type="checkbox"/>	<input type="checkbox"/>	<input type="checkbox"/>
1104 pin	<input type="checkbox"/>	<input type="checkbox"/>	<input type="checkbox"/>	<input type="checkbox"/>	<input type="checkbox"/>
1105 cylinder	<input type="checkbox"/>	<input type="checkbox"/>	<input type="checkbox"/>	<input type="checkbox"/>	<input type="checkbox"/>
1106 boom speed	<input type="checkbox"/>	<input type="checkbox"/>	<input type="checkbox"/>	<input type="checkbox"/>	<input type="checkbox"/>
1107 pressure settings	<input type="checkbox"/>	<input type="checkbox"/>	<input type="checkbox"/>	<input type="checkbox"/>	<input type="checkbox"/>
1108 hydraulic lines	<input type="checkbox"/>	<input type="checkbox"/>	<input type="checkbox"/>	<input type="checkbox"/>	<input type="checkbox"/>
1109 load holding valve (piston side)	<input type="checkbox"/>	<input type="checkbox"/>	<input type="checkbox"/>	<input type="checkbox"/>	<input type="checkbox"/>
1110 load holding valve (rod side)	<input type="checkbox"/>	<input type="checkbox"/>	<input type="checkbox"/>	<input type="checkbox"/>	<input type="checkbox"/>

1200 joint "D"

1201 boom	<input type="checkbox"/>	<input type="checkbox"/>	<input type="checkbox"/>	<input type="checkbox"/>	<input type="checkbox"/>
1202 link lever	<input type="checkbox"/>	<input type="checkbox"/>	<input type="checkbox"/>	<input type="checkbox"/>	<input type="checkbox"/>
1203 forcing rod	<input type="checkbox"/>	<input type="checkbox"/>	<input type="checkbox"/>	<input type="checkbox"/>	<input type="checkbox"/>
1204 pin	<input type="checkbox"/>	<input type="checkbox"/>	<input type="checkbox"/>	<input type="checkbox"/>	<input type="checkbox"/>
1205 cylinder	<input type="checkbox"/>	<input type="checkbox"/>	<input type="checkbox"/>	<input type="checkbox"/>	<input type="checkbox"/>
1206 boom speed	<input type="checkbox"/>	<input type="checkbox"/>	<input type="checkbox"/>	<input type="checkbox"/>	<input type="checkbox"/>
1207 pressure settings	<input type="checkbox"/>	<input type="checkbox"/>	<input type="checkbox"/>	<input type="checkbox"/>	<input type="checkbox"/>
1208 hydraulic lines	<input type="checkbox"/>	<input type="checkbox"/>	<input type="checkbox"/>	<input type="checkbox"/>	<input type="checkbox"/>
1209 load holding valve (piston side)	<input type="checkbox"/>	<input type="checkbox"/>	<input type="checkbox"/>	<input type="checkbox"/>	<input type="checkbox"/>
1210 load holding valve (rod side)	<input type="checkbox"/>	<input type="checkbox"/>	<input type="checkbox"/>	<input type="checkbox"/>	<input type="checkbox"/>

1300 joint „E“

1301 boom	<input type="checkbox"/>	<input type="checkbox"/>	<input type="checkbox"/>	<input type="checkbox"/>	<input type="checkbox"/>
1302 link lever	<input type="checkbox"/>	<input type="checkbox"/>	<input type="checkbox"/>	<input type="checkbox"/>	<input type="checkbox"/>
1303 forcing rod	<input type="checkbox"/>	<input type="checkbox"/>	<input type="checkbox"/>	<input type="checkbox"/>	<input type="checkbox"/>
1304 pin	<input type="checkbox"/>	<input type="checkbox"/>	<input type="checkbox"/>	<input type="checkbox"/>	<input type="checkbox"/>
1305 cylinder	<input type="checkbox"/>	<input type="checkbox"/>	<input type="checkbox"/>	<input type="checkbox"/>	<input type="checkbox"/>
1306 boom speed	<input type="checkbox"/>	<input type="checkbox"/>	<input type="checkbox"/>	<input type="checkbox"/>	<input type="checkbox"/>
1307 pressure settings	<input type="checkbox"/>	<input type="checkbox"/>	<input type="checkbox"/>	<input type="checkbox"/>	<input type="checkbox"/>
1308 hydraulic lines	<input type="checkbox"/>	<input type="checkbox"/>	<input type="checkbox"/>	<input type="checkbox"/>	<input type="checkbox"/>
1309 load holding valve (piston side)	<input type="checkbox"/>	<input type="checkbox"/>	<input type="checkbox"/>	<input type="checkbox"/>	<input type="checkbox"/>
1310 load holding valve (rod side)	<input type="checkbox"/>	<input type="checkbox"/>	<input type="checkbox"/>	<input type="checkbox"/>	<input type="checkbox"/>

1400 concrete delivery line

1401 assembly of delivery line DN	<input type="checkbox"/>	<input type="checkbox"/>	<input type="checkbox"/>	<input type="checkbox"/>	<input type="checkbox"/>
1402 end hose DN+lenght	<input type="checkbox"/>	<input type="checkbox"/>	<input type="checkbox"/>	<input type="checkbox"/>	<input type="checkbox"/>
1403 delivery line DN	<input type="checkbox"/>	<input type="checkbox"/>	<input type="checkbox"/>	<input type="checkbox"/>	<input type="checkbox"/>
1404 rotating joints of - delivery line	<input type="checkbox"/>	<input type="checkbox"/>	<input type="checkbox"/>	<input type="checkbox"/>	<input type="checkbox"/>
1405 locking pin of the coupling	<input type="checkbox"/>	<input type="checkbox"/>	<input type="checkbox"/>	<input type="checkbox"/>	<input type="checkbox"/>

Notes:

--	--

Inspection report for concrete booms

Inspection report Nr: _____ Boom type: _____ Machine-Nr: _____

Error code:

- | | | | |
|------------------|---------------------|-------------------|--------------------------|
| 00 no objections | 08 corrosion | 16 porous | 24 deformation |
| 01 cracks | 09 lacquer failures | 17 burned through | 25 bear movement |
| 02 broken | 10 fraying | 18 not fixed | 26 lubrication |
| 03 leaky | 11 scratched | 19 clemp | 27 readability |
| 04 no function | 12 bendet | 20 sawing | 28 missing components |
| 05 low lifetime | 13 noises | 21 contaminated | 29 hydraulical |
| 06 worn out | 14 vibration | 22 bad contact | 30 electrical |
| 07 dirt | 15 miscellaneous | 23 temperature | 31 reinspection required |

<p>1406 end hose safety device <input type="checkbox"/> <input type="checkbox"/> <input type="checkbox"/> <input type="checkbox"/> <input type="checkbox"/></p> <p>1407 reducer <input type="checkbox"/> <input type="checkbox"/> <input type="checkbox"/> <input type="checkbox"/> <input type="checkbox"/></p> <p>1408 gate elbow, elbow 6" <input type="checkbox"/> <input type="checkbox"/> <input type="checkbox"/> <input type="checkbox"/> <input type="checkbox"/></p> <p>1500 hydraulic system and hydraulic valves</p> <p>1501 Pressure relief valve <input type="checkbox"/> <input type="checkbox"/> <input type="checkbox"/> <input type="checkbox"/> <input type="checkbox"/></p> <p>1502 pressure settings <input type="checkbox"/> <input type="checkbox"/> <input type="checkbox"/> <input type="checkbox"/> <input type="checkbox"/></p> <p>1503 hydraulic lines <input type="checkbox"/> <input type="checkbox"/> <input type="checkbox"/> <input type="checkbox"/> <input type="checkbox"/></p> <p>1504 hand operating- (function) <input type="checkbox"/> <input type="checkbox"/> <input type="checkbox"/> <input type="checkbox"/> <input type="checkbox"/></p> <p>1505 boom control valve <input type="checkbox"/> <input type="checkbox"/> <input type="checkbox"/> <input type="checkbox"/> <input type="checkbox"/></p> <p>1506 hydraulic pump <input type="checkbox"/> <input type="checkbox"/> <input type="checkbox"/> <input type="checkbox"/> <input type="checkbox"/></p> <p>1600 electric equipment</p> <p>1601 remote control (functions) <input type="checkbox"/> <input type="checkbox"/> <input type="checkbox"/> <input type="checkbox"/> <input type="checkbox"/></p> <p>1602 emergency stop (function) <input type="checkbox"/> <input type="checkbox"/> <input type="checkbox"/> <input type="checkbox"/> <input type="checkbox"/></p> <p>1603 switch for outrigger function <input type="checkbox"/> <input type="checkbox"/> <input type="checkbox"/> <input type="checkbox"/> <input type="checkbox"/></p> <p>1604 switch for boom function <input type="checkbox"/> <input type="checkbox"/> <input type="checkbox"/> <input type="checkbox"/> <input type="checkbox"/></p> <p>1605 wiring harness <input type="checkbox"/> <input type="checkbox"/> <input type="checkbox"/> <input type="checkbox"/> <input type="checkbox"/></p> <p>1606 central lubrication <input type="checkbox"/> <input type="checkbox"/> <input type="checkbox"/> <input type="checkbox"/> <input type="checkbox"/></p>	<p>1700 sticker sets</p> <p>1701 safety hints <input type="checkbox"/> <input type="checkbox"/> <input type="checkbox"/> <input type="checkbox"/> <input type="checkbox"/></p> <p>1702 description <input type="checkbox"/> <input type="checkbox"/> <input type="checkbox"/> <input type="checkbox"/> <input type="checkbox"/></p> <p>1703 operating <input type="checkbox"/> <input type="checkbox"/> <input type="checkbox"/> <input type="checkbox"/> <input type="checkbox"/></p> <p>1704 short operating instruction <input type="checkbox"/> <input type="checkbox"/> <input type="checkbox"/> <input type="checkbox"/> <input type="checkbox"/></p> <p>1705 sticker „ don't use the boom as crane“ <input type="checkbox"/> <input type="checkbox"/> <input type="checkbox"/> <input type="checkbox"/> <input type="checkbox"/></p> <p>1706 sticker „guideline operating with boom- and concrete pump“ <input type="checkbox"/> <input type="checkbox"/> <input type="checkbox"/> <input type="checkbox"/> <input type="checkbox"/></p> <p>1707 name plate <input type="checkbox"/> <input type="checkbox"/> <input type="checkbox"/> <input type="checkbox"/> <input type="checkbox"/></p> <p>1708 sticker „danger high voltage“ <input type="checkbox"/> <input type="checkbox"/> <input type="checkbox"/> <input type="checkbox"/> <input type="checkbox"/></p> <p>Competent inspector:</p> <p>Date: _____</p> <p>Name: _____</p> <p>Signature: _____ (stamp)</p> <p>Customer:</p> <p>Signature: _____ (stamp)</p>
---	--

Inspection report for concrete pump

Inspection report Nr:	Machine-Nr:	Hours of operation:
		Concrete output m ³ :
Company:	Post code:	City:

NL	WV
----	----

Proof – Result of the tests

without defects	defects	reinspection required	shut down
<input type="checkbox"/>	<input type="checkbox"/>	<input type="checkbox"/>	<input type="checkbox"/>

Reinspection until date:

Error code:

- | | | | |
|------------------|---------------------|-------------------|--------------------------|
| 00 no objections | 08 corrosion | 16 porous | 24 deformation |
| 01 cracks | 09 lacquer failures | 17 burned through | 25 bear movement |
| 02 broken | 10 fraying | 18 not fixed | 26 lubrication |
| 03 leaky | 11 scratched | 19 clemp | 27 readability |
| 04 no fuction | 12 bendet | 20 sawing | 28 missing components |
| 05 low livetime | 13 noises | 21 contaminated | 29 hydraulical |
| 06 worn out | 14 vibration | 22 bad contact | 30 electrical |
| 07 dirt | 15 miscellaneous | 23 temperature | 31 reinspection required |

2000 documents

2001 operating manual

2002 spare parts list

2100 drive assembly

2101 coupling and flange

2200 gear box

2300 hydraulic pump (main)

2400 oil-tank

2500 drive shaft

2700 hydraulic control system

2701 pressure relief valve

2702 pressure setting

2703 hydraulic line

2704 mechanical operation by hand

2800 oil –cooler

2900 accumulator

2901 proofs of the required tests according to accumulator regulation

2902 pressure gauge

Notes:

Inspection report for concrete pump

Inspection report Nr:		Machine-Nr:																																													
<p>Error code:</p> <table style="width: 100%; border: none;"> <tr> <td style="width: 25%;">00 no objections</td> <td style="width: 25%;">08 corrosion</td> <td style="width: 25%;">16 porous</td> <td style="width: 25%;">24 deformation</td> </tr> <tr> <td>01 cracks</td> <td>09 lacquer failures</td> <td>17 burned through</td> <td>25 bear movement</td> </tr> <tr> <td>02 broken</td> <td>10 fraying</td> <td>18 not fixed</td> <td>26 lubrication</td> </tr> <tr> <td>03 leaky</td> <td>11 scratched</td> <td>19 clomp</td> <td>27 readability</td> </tr> <tr> <td>04 no function</td> <td>12 bendet</td> <td>20 sawing</td> <td>28 missing components</td> </tr> <tr> <td>05 low lifetime</td> <td>13 noises</td> <td>21 contamitated</td> <td>29 hydraulical</td> </tr> <tr> <td>06 worn out</td> <td>14 vibration</td> <td>22 bad contact</td> <td>30 electrical</td> </tr> <tr> <td>07 dirt</td> <td>15 miscellaneous</td> <td>23 temperature</td> <td>31 reinspection required</td> </tr> </table>				00 no objections	08 corrosion	16 porous	24 deformation	01 cracks	09 lacquer failures	17 burned through	25 bear movement	02 broken	10 fraying	18 not fixed	26 lubrication	03 leaky	11 scratched	19 clomp	27 readability	04 no function	12 bendet	20 sawing	28 missing components	05 low lifetime	13 noises	21 contamitated	29 hydraulical	06 worn out	14 vibration	22 bad contact	30 electrical	07 dirt	15 miscellaneous	23 temperature	31 reinspection required												
00 no objections	08 corrosion	16 porous	24 deformation																																												
01 cracks	09 lacquer failures	17 burned through	25 bear movement																																												
02 broken	10 fraying	18 not fixed	26 lubrication																																												
03 leaky	11 scratched	19 clomp	27 readability																																												
04 no function	12 bendet	20 sawing	28 missing components																																												
05 low lifetime	13 noises	21 contamitated	29 hydraulical																																												
06 worn out	14 vibration	22 bad contact	30 electrical																																												
07 dirt	15 miscellaneous	23 temperature	31 reinspection required																																												
<table style="width: 100%; border: none;"> <tr> <td style="width: 80%;">3000 central lubrication</td> <td style="width: 20%; text-align: center;"><input type="checkbox"/><input type="checkbox"/><input type="checkbox"/><input type="checkbox"/><input type="checkbox"/></td> </tr> <tr> <td>3100 hydraulic motor</td> <td style="text-align: center;"><input type="checkbox"/><input type="checkbox"/><input type="checkbox"/><input type="checkbox"/><input type="checkbox"/></td> </tr> <tr> <td>3200 hydraulic lines</td> <td style="text-align: center;"><input type="checkbox"/><input type="checkbox"/><input type="checkbox"/><input type="checkbox"/><input type="checkbox"/></td> </tr> <tr> <td>3300 air compressor</td> <td style="text-align: center;"><input type="checkbox"/><input type="checkbox"/><input type="checkbox"/><input type="checkbox"/><input type="checkbox"/></td> </tr> <tr> <td>3400 control panel</td> <td style="text-align: center;"><input type="checkbox"/><input type="checkbox"/><input type="checkbox"/><input type="checkbox"/><input type="checkbox"/></td> </tr> <tr> <td>3500 concrete pump</td> <td style="text-align: center;"><input type="checkbox"/><input type="checkbox"/><input type="checkbox"/><input type="checkbox"/><input type="checkbox"/></td> </tr> <tr> <td>3700 S-valve</td> <td style="text-align: center;"><input type="checkbox"/><input type="checkbox"/><input type="checkbox"/><input type="checkbox"/><input type="checkbox"/></td> </tr> <tr> <td>3800 hopper</td> <td style="text-align: center;"><input type="checkbox"/><input type="checkbox"/><input type="checkbox"/><input type="checkbox"/><input type="checkbox"/></td> </tr> <tr> <td>4100 sub frame</td> <td style="text-align: center;"><input type="checkbox"/><input type="checkbox"/><input type="checkbox"/><input type="checkbox"/><input type="checkbox"/></td> </tr> <tr> <td>4200 water tank</td> <td style="text-align: center;"><input type="checkbox"/><input type="checkbox"/><input type="checkbox"/><input type="checkbox"/><input type="checkbox"/></td> </tr> <tr> <td>4300 axle</td> <td style="text-align: center;"><input type="checkbox"/><input type="checkbox"/><input type="checkbox"/><input type="checkbox"/><input type="checkbox"/></td> </tr> <tr> <td>4400 water pump</td> <td style="text-align: center;"><input type="checkbox"/><input type="checkbox"/><input type="checkbox"/><input type="checkbox"/><input type="checkbox"/></td> </tr> <tr> <td>4500 vibrator</td> <td style="text-align: center;"><input type="checkbox"/><input type="checkbox"/><input type="checkbox"/><input type="checkbox"/><input type="checkbox"/></td> </tr> </table>	3000 central lubrication	<input type="checkbox"/> <input type="checkbox"/> <input type="checkbox"/> <input type="checkbox"/> <input type="checkbox"/>	3100 hydraulic motor	<input type="checkbox"/> <input type="checkbox"/> <input type="checkbox"/> <input type="checkbox"/> <input type="checkbox"/>	3200 hydraulic lines	<input type="checkbox"/> <input type="checkbox"/> <input type="checkbox"/> <input type="checkbox"/> <input type="checkbox"/>	3300 air compressor	<input type="checkbox"/> <input type="checkbox"/> <input type="checkbox"/> <input type="checkbox"/> <input type="checkbox"/>	3400 control panel	<input type="checkbox"/> <input type="checkbox"/> <input type="checkbox"/> <input type="checkbox"/> <input type="checkbox"/>	3500 concrete pump	<input type="checkbox"/> <input type="checkbox"/> <input type="checkbox"/> <input type="checkbox"/> <input type="checkbox"/>	3700 S-valve	<input type="checkbox"/> <input type="checkbox"/> <input type="checkbox"/> <input type="checkbox"/> <input type="checkbox"/>	3800 hopper	<input type="checkbox"/> <input type="checkbox"/> <input type="checkbox"/> <input type="checkbox"/> <input type="checkbox"/>	4100 sub frame	<input type="checkbox"/> <input type="checkbox"/> <input type="checkbox"/> <input type="checkbox"/> <input type="checkbox"/>	4200 water tank	<input type="checkbox"/> <input type="checkbox"/> <input type="checkbox"/> <input type="checkbox"/> <input type="checkbox"/>	4300 axle	<input type="checkbox"/> <input type="checkbox"/> <input type="checkbox"/> <input type="checkbox"/> <input type="checkbox"/>	4400 water pump	<input type="checkbox"/> <input type="checkbox"/> <input type="checkbox"/> <input type="checkbox"/> <input type="checkbox"/>	4500 vibrator	<input type="checkbox"/> <input type="checkbox"/> <input type="checkbox"/> <input type="checkbox"/> <input type="checkbox"/>	<p>4600 safety guards, equipment</p> <table style="width: 100%; border: none;"> <tr> <td style="width: 80%;">4601 stair</td> <td style="width: 20%; text-align: center;"><input type="checkbox"/><input type="checkbox"/><input type="checkbox"/><input type="checkbox"/><input type="checkbox"/></td> </tr> <tr> <td>4602 safety for stair</td> <td style="text-align: center;"><input type="checkbox"/><input type="checkbox"/><input type="checkbox"/><input type="checkbox"/><input type="checkbox"/></td> </tr> <tr> <td>4603 handrail</td> <td style="text-align: center;"><input type="checkbox"/><input type="checkbox"/><input type="checkbox"/><input type="checkbox"/><input type="checkbox"/></td> </tr> <tr> <td>4604 hopper grid (fixing device)</td> <td style="text-align: center;"><input type="checkbox"/><input type="checkbox"/><input type="checkbox"/><input type="checkbox"/><input type="checkbox"/></td> </tr> <tr> <td>4606 distance of grid rods</td> <td style="text-align: center;"><input type="checkbox"/><input type="checkbox"/><input type="checkbox"/><input type="checkbox"/><input type="checkbox"/></td> </tr> <tr> <td>4607 distance from grid to agitator</td> <td style="text-align: center;"><input type="checkbox"/><input type="checkbox"/><input type="checkbox"/><input type="checkbox"/><input type="checkbox"/></td> </tr> <tr> <td>4609 agitator have to stop if grid is open</td> <td style="text-align: center;"><input type="checkbox"/><input type="checkbox"/><input type="checkbox"/><input type="checkbox"/><input type="checkbox"/></td> </tr> <tr> <td>4610 accumulator have to dump if grid is open</td> <td style="text-align: center;"><input type="checkbox"/><input type="checkbox"/><input type="checkbox"/><input type="checkbox"/><input type="checkbox"/></td> </tr> <tr> <td>4612 cleaning flap hopper</td> <td style="text-align: center;"><input type="checkbox"/><input type="checkbox"/><input type="checkbox"/><input type="checkbox"/><input type="checkbox"/></td> </tr> <tr> <td>4613 safety grid into water box</td> <td style="text-align: center;"><input type="checkbox"/><input type="checkbox"/><input type="checkbox"/><input type="checkbox"/><input type="checkbox"/></td> </tr> </table> <p>Notes:</p> <div style="border: 1px solid black; height: 40px; margin-bottom: 5px;"></div> <div style="border: 1px solid black; height: 40px; margin-bottom: 5px;"></div> <div style="border: 1px solid black; height: 40px; margin-bottom: 5px;"></div> <div style="border: 1px solid black; height: 40px; margin-bottom: 5px;"></div>	4601 stair	<input type="checkbox"/> <input type="checkbox"/> <input type="checkbox"/> <input type="checkbox"/> <input type="checkbox"/>	4602 safety for stair	<input type="checkbox"/> <input type="checkbox"/> <input type="checkbox"/> <input type="checkbox"/> <input type="checkbox"/>	4603 handrail	<input type="checkbox"/> <input type="checkbox"/> <input type="checkbox"/> <input type="checkbox"/> <input type="checkbox"/>	4604 hopper grid (fixing device)	<input type="checkbox"/> <input type="checkbox"/> <input type="checkbox"/> <input type="checkbox"/> <input type="checkbox"/>	4606 distance of grid rods	<input type="checkbox"/> <input type="checkbox"/> <input type="checkbox"/> <input type="checkbox"/> <input type="checkbox"/>	4607 distance from grid to agitator	<input type="checkbox"/> <input type="checkbox"/> <input type="checkbox"/> <input type="checkbox"/> <input type="checkbox"/>	4609 agitator have to stop if grid is open	<input type="checkbox"/> <input type="checkbox"/> <input type="checkbox"/> <input type="checkbox"/> <input type="checkbox"/>	4610 accumulator have to dump if grid is open	<input type="checkbox"/> <input type="checkbox"/> <input type="checkbox"/> <input type="checkbox"/> <input type="checkbox"/>	4612 cleaning flap hopper	<input type="checkbox"/> <input type="checkbox"/> <input type="checkbox"/> <input type="checkbox"/> <input type="checkbox"/>	4613 safety grid into water box	<input type="checkbox"/> <input type="checkbox"/> <input type="checkbox"/> <input type="checkbox"/> <input type="checkbox"/>
3000 central lubrication	<input type="checkbox"/> <input type="checkbox"/> <input type="checkbox"/> <input type="checkbox"/> <input type="checkbox"/>																																														
3100 hydraulic motor	<input type="checkbox"/> <input type="checkbox"/> <input type="checkbox"/> <input type="checkbox"/> <input type="checkbox"/>																																														
3200 hydraulic lines	<input type="checkbox"/> <input type="checkbox"/> <input type="checkbox"/> <input type="checkbox"/> <input type="checkbox"/>																																														
3300 air compressor	<input type="checkbox"/> <input type="checkbox"/> <input type="checkbox"/> <input type="checkbox"/> <input type="checkbox"/>																																														
3400 control panel	<input type="checkbox"/> <input type="checkbox"/> <input type="checkbox"/> <input type="checkbox"/> <input type="checkbox"/>																																														
3500 concrete pump	<input type="checkbox"/> <input type="checkbox"/> <input type="checkbox"/> <input type="checkbox"/> <input type="checkbox"/>																																														
3700 S-valve	<input type="checkbox"/> <input type="checkbox"/> <input type="checkbox"/> <input type="checkbox"/> <input type="checkbox"/>																																														
3800 hopper	<input type="checkbox"/> <input type="checkbox"/> <input type="checkbox"/> <input type="checkbox"/> <input type="checkbox"/>																																														
4100 sub frame	<input type="checkbox"/> <input type="checkbox"/> <input type="checkbox"/> <input type="checkbox"/> <input type="checkbox"/>																																														
4200 water tank	<input type="checkbox"/> <input type="checkbox"/> <input type="checkbox"/> <input type="checkbox"/> <input type="checkbox"/>																																														
4300 axle	<input type="checkbox"/> <input type="checkbox"/> <input type="checkbox"/> <input type="checkbox"/> <input type="checkbox"/>																																														
4400 water pump	<input type="checkbox"/> <input type="checkbox"/> <input type="checkbox"/> <input type="checkbox"/> <input type="checkbox"/>																																														
4500 vibrator	<input type="checkbox"/> <input type="checkbox"/> <input type="checkbox"/> <input type="checkbox"/> <input type="checkbox"/>																																														
4601 stair	<input type="checkbox"/> <input type="checkbox"/> <input type="checkbox"/> <input type="checkbox"/> <input type="checkbox"/>																																														
4602 safety for stair	<input type="checkbox"/> <input type="checkbox"/> <input type="checkbox"/> <input type="checkbox"/> <input type="checkbox"/>																																														
4603 handrail	<input type="checkbox"/> <input type="checkbox"/> <input type="checkbox"/> <input type="checkbox"/> <input type="checkbox"/>																																														
4604 hopper grid (fixing device)	<input type="checkbox"/> <input type="checkbox"/> <input type="checkbox"/> <input type="checkbox"/> <input type="checkbox"/>																																														
4606 distance of grid rods	<input type="checkbox"/> <input type="checkbox"/> <input type="checkbox"/> <input type="checkbox"/> <input type="checkbox"/>																																														
4607 distance from grid to agitator	<input type="checkbox"/> <input type="checkbox"/> <input type="checkbox"/> <input type="checkbox"/> <input type="checkbox"/>																																														
4609 agitator have to stop if grid is open	<input type="checkbox"/> <input type="checkbox"/> <input type="checkbox"/> <input type="checkbox"/> <input type="checkbox"/>																																														
4610 accumulator have to dump if grid is open	<input type="checkbox"/> <input type="checkbox"/> <input type="checkbox"/> <input type="checkbox"/> <input type="checkbox"/>																																														
4612 cleaning flap hopper	<input type="checkbox"/> <input type="checkbox"/> <input type="checkbox"/> <input type="checkbox"/> <input type="checkbox"/>																																														
4613 safety grid into water box	<input type="checkbox"/> <input type="checkbox"/> <input type="checkbox"/> <input type="checkbox"/> <input type="checkbox"/>																																														

Inspection report for concrete pump

Inspection report Nr: _____ Machine-Nr: _____

Error code:

- | | | | |
|------------------|---------------------|-------------------|--------------------------|
| 00 no objections | 08 corrosion | 16 porous | 24 deformation |
| 01 cracks | 09 lacquer failures | 17 burned through | 25 bear movement |
| 02 broken | 10 fraying | 18 not fixed | 26 lubrication |
| 03 leaky | 11 scratched | 19 clemp | 27 readability |
| 04 no function | 12 bendet | 20 sawing | 28 missing components |
| 05 low lifetime | 13 noises | 21 contamitated | 29 hydraulical |
| 06 worn out | 14 vibration | 22 bad contact | 30 electrical |
| 07 dirt | 15 miscellaneous | 23 temperature | 31 reinspection required |

<p>4614 cover for rotating wave <input type="checkbox"/> <input type="checkbox"/> <input type="checkbox"/> <input type="checkbox"/> <input type="checkbox"/></p> <p>4616 cover for chains <input type="checkbox"/> <input type="checkbox"/> <input type="checkbox"/> <input type="checkbox"/> <input type="checkbox"/></p> <p>4617 cover for shift cylinder <input type="checkbox"/> <input type="checkbox"/> <input type="checkbox"/> <input type="checkbox"/> <input type="checkbox"/></p> <p>4618 cover for moving parts <input type="checkbox"/> <input type="checkbox"/> <input type="checkbox"/> <input type="checkbox"/> <input type="checkbox"/></p> <p>4619 cover for the exhaust pipe <input type="checkbox"/> <input type="checkbox"/> <input type="checkbox"/> <input type="checkbox"/> <input type="checkbox"/></p> <p>4700 electrical system</p> <p>4701 function of actuator component <input type="checkbox"/> <input type="checkbox"/> <input type="checkbox"/> <input type="checkbox"/> <input type="checkbox"/></p> <p>4702 emergency stop function <input type="checkbox"/> <input type="checkbox"/> <input type="checkbox"/> <input type="checkbox"/> <input type="checkbox"/></p> <p>4703 ground connections <input type="checkbox"/> <input type="checkbox"/> <input type="checkbox"/> <input type="checkbox"/> <input type="checkbox"/></p> <p>4704 cables and wiring harness <input type="checkbox"/> <input type="checkbox"/> <input type="checkbox"/> <input type="checkbox"/> <input type="checkbox"/></p> <p>4705 temperature switch <input type="checkbox"/> <input type="checkbox"/> <input type="checkbox"/> <input type="checkbox"/> <input type="checkbox"/></p> <p>4800 outrigger - system</p> <p>4801 transportation lock <input type="checkbox"/> <input type="checkbox"/> <input type="checkbox"/> <input type="checkbox"/> <input type="checkbox"/></p> <p>4802 locking device <input type="checkbox"/> <input type="checkbox"/> <input type="checkbox"/> <input type="checkbox"/> <input type="checkbox"/></p> <p>4803 backing plate <input type="checkbox"/> <input type="checkbox"/> <input type="checkbox"/> <input type="checkbox"/> <input type="checkbox"/></p>	<p>4804 jack cylinder connections <input type="checkbox"/> <input type="checkbox"/> <input type="checkbox"/> <input type="checkbox"/> <input type="checkbox"/></p> <p>4805 pressure adjustment of jack cylinder <input type="checkbox"/> <input type="checkbox"/> <input type="checkbox"/> <input type="checkbox"/> <input type="checkbox"/></p> <p>4900 miscellaneous</p> <p>4901 additional assembled part from operator <input type="checkbox"/> <input type="checkbox"/> <input type="checkbox"/> <input type="checkbox"/> <input type="checkbox"/></p> <p>4902 changes through operator <input type="checkbox"/> <input type="checkbox"/> <input type="checkbox"/> <input type="checkbox"/> <input type="checkbox"/></p> <p>Competent inspector:</p> <p>Date:</p> <p>Name:</p> <p>Signature: (stamp)</p> <p>Customer:</p> <p>Signature: (stamp)</p> <p style="text-align: center;">This test report is filed into the test book</p>
---	---

Inspection report for concrete booms

Inspection report -Nr:	Machine-Nr:	Hours of operation:
		Concrete output m ³ :
Company:	Post code:	City:
Boom Type:	Boom Nr.:	NL WV

Proof - Result of the Tests

without defects	defects	reinspection required	shut down
<input type="checkbox"/>	<input type="checkbox"/>	<input type="checkbox"/>	<input type="checkbox"/>

Reinspection until date:

Error code:

- | | | | |
|------------------|---------------------|-------------------|--------------------------|
| 00 no objections | 08 corrosion | 16 porous | 24 deformation |
| 01 cracks | 09 lacquer failures | 17 burned through | 25 bear movement |
| 02 broken | 10 fraying | 18 not fixed | 26 lubrication |
| 03 leaky | 11 scratched | 19 clomp | 27 readability |
| 04 no function | 12 bendet | 20 sawing | 28 missing components |
| 05 low lifetime | 13 noises | 21 contaminated | 29 hydraulical |
| 06 worn out | 14 vibration | 22 bad contact | 30 electrical |
| 07 dirt | 15 miscellaneous | 23 temperature | 31 reinspection required |

<p>100 documents</p> <p>101 instruction manual <input type="checkbox"/> <input type="checkbox"/> <input type="checkbox"/> <input type="checkbox"/> <input type="checkbox"/></p> <p>102 spare parts list <input type="checkbox"/> <input type="checkbox"/> <input type="checkbox"/> <input type="checkbox"/> <input type="checkbox"/></p> <p>200 sub frame</p> <p>201 frame connection cpl. <input type="checkbox"/> <input type="checkbox"/> <input type="checkbox"/> <input type="checkbox"/> <input type="checkbox"/></p> <p>300 outrigger front R+L</p> <p>301 transportation safety device <input type="checkbox"/> <input type="checkbox"/> <input type="checkbox"/> <input type="checkbox"/> <input type="checkbox"/></p> <p>302 outrigger <input type="checkbox"/> <input type="checkbox"/> <input type="checkbox"/> <input type="checkbox"/> <input type="checkbox"/></p> <p>303 extension box <input type="checkbox"/> <input type="checkbox"/> <input type="checkbox"/> <input type="checkbox"/> <input type="checkbox"/></p> <p>304 locking device <input type="checkbox"/> <input type="checkbox"/> <input type="checkbox"/> <input type="checkbox"/> <input type="checkbox"/></p> <p>305 slewing bearing <input type="checkbox"/> <input type="checkbox"/> <input type="checkbox"/> <input type="checkbox"/> <input type="checkbox"/></p> <p>306 turn locking device <input type="checkbox"/> <input type="checkbox"/> <input type="checkbox"/> <input type="checkbox"/> <input type="checkbox"/></p> <p>307 support safeguard <input type="checkbox"/> <input type="checkbox"/> <input type="checkbox"/> <input type="checkbox"/> <input type="checkbox"/></p> <p>308 support plate <input type="checkbox"/> <input type="checkbox"/> <input type="checkbox"/> <input type="checkbox"/> <input type="checkbox"/></p> <p>309 fixing of jack cylinder <input type="checkbox"/> <input type="checkbox"/> <input type="checkbox"/> <input type="checkbox"/> <input type="checkbox"/></p> <p>310 jack cylinder <input type="checkbox"/> <input type="checkbox"/> <input type="checkbox"/> <input type="checkbox"/> <input type="checkbox"/></p>	<p>311 swing cylinder <input type="checkbox"/> <input type="checkbox"/> <input type="checkbox"/> <input type="checkbox"/> <input type="checkbox"/></p> <p>312 telescopic-cylinder <input type="checkbox"/> <input type="checkbox"/> <input type="checkbox"/> <input type="checkbox"/> <input type="checkbox"/></p> <p>313 pressure adjustment <input type="checkbox"/> <input type="checkbox"/> <input type="checkbox"/> <input type="checkbox"/> <input type="checkbox"/></p> <p>400 outrigger rear L+R</p> <p>401 transportation safety device <input type="checkbox"/> <input type="checkbox"/> <input type="checkbox"/> <input type="checkbox"/> <input type="checkbox"/></p> <p>402 outrigger <input type="checkbox"/> <input type="checkbox"/> <input type="checkbox"/> <input type="checkbox"/> <input type="checkbox"/></p> <p>403 extension box <input type="checkbox"/> <input type="checkbox"/> <input type="checkbox"/> <input type="checkbox"/> <input type="checkbox"/></p> <p>405 locking device <input type="checkbox"/> <input type="checkbox"/> <input type="checkbox"/> <input type="checkbox"/> <input type="checkbox"/></p> <p>Notes:</p> <hr/> <hr/> <hr/> <hr/> <hr/>
--	---

Inspection report for concrete booms

Inspection report Nr: _____ Boom type: _____ Machine-Nr: _____

- | | | | |
|------------------|---------------------|-------------------|--------------------------|
| Error code: | | | |
| 00 no objections | 08 corrosion | 16 porous | 24 deformation |
| 01 cracks | 09 lacquer failures | 17 burned through | 25 bear movement |
| 02 broken | 10 fraying | 18 not fixed | 26 lubrication |
| 03 leaky | 11 scratched | 19 clomp | 27 readability |
| 04 no function | 12 bendet | 20 sawing | 28 missing components |
| 05 low lifetime | 13 noises | 21 contaminated | 29 hydraulic |
| 06 worn out | 14 vibration | 22 bad contact | 30 electrical |
| 07 dirt | 15 miscellaneous | 23 temperature | 31 reinspection required |

<table border="0" style="width: 100%;"> <tr> <td style="width: 30%;">406 slewing bearing</td> <td style="width: 20%;"><input type="checkbox"/></td> <td style="width: 20%;"><input type="checkbox"/></td> <td style="width: 20%;"><input type="checkbox"/></td> <td style="width: 20%;"><input type="checkbox"/></td> <td style="width: 20%;"><input type="checkbox"/></td> </tr> <tr> <td>407 turn locking device</td> <td><input type="checkbox"/></td> <td><input type="checkbox"/></td> <td><input type="checkbox"/></td> <td><input type="checkbox"/></td> <td><input type="checkbox"/></td> </tr> <tr> <td>408 support safeguard</td> <td><input type="checkbox"/></td> <td><input type="checkbox"/></td> <td><input type="checkbox"/></td> <td><input type="checkbox"/></td> <td><input type="checkbox"/></td> </tr> <tr> <td>409 support plate</td> <td><input type="checkbox"/></td> <td><input type="checkbox"/></td> <td><input type="checkbox"/></td> <td><input type="checkbox"/></td> <td><input type="checkbox"/></td> </tr> <tr> <td>410 fixing of jack cylinder</td> <td><input type="checkbox"/></td> <td><input type="checkbox"/></td> <td><input type="checkbox"/></td> <td><input type="checkbox"/></td> <td><input type="checkbox"/></td> </tr> <tr> <td>411 jack cylinder</td> <td><input type="checkbox"/></td> <td><input type="checkbox"/></td> <td><input type="checkbox"/></td> <td><input type="checkbox"/></td> <td><input type="checkbox"/></td> </tr> <tr> <td>412 swing cylinder</td> <td><input type="checkbox"/></td> <td><input type="checkbox"/></td> <td><input type="checkbox"/></td> <td><input type="checkbox"/></td> <td><input type="checkbox"/></td> </tr> <tr> <td>413 telescopic cylinder</td> <td><input type="checkbox"/></td> <td><input type="checkbox"/></td> <td><input type="checkbox"/></td> <td><input type="checkbox"/></td> <td><input type="checkbox"/></td> </tr> <tr> <td colspan="6"> </td> </tr> <tr> <td>500 pedestal</td> <td colspan="5"></td> </tr> <tr> <td>501 pedestal mounting</td> <td><input type="checkbox"/></td> <td><input type="checkbox"/></td> <td><input type="checkbox"/></td> <td><input type="checkbox"/></td> <td><input type="checkbox"/></td> </tr> <tr> <td>502 sub frame</td> <td><input type="checkbox"/></td> <td><input type="checkbox"/></td> <td><input type="checkbox"/></td> <td><input type="checkbox"/></td> <td><input type="checkbox"/></td> </tr> <tr> <td>503 truck frame</td> <td><input type="checkbox"/></td> <td><input type="checkbox"/></td> <td><input type="checkbox"/></td> <td><input type="checkbox"/></td> <td><input type="checkbox"/></td> </tr> <tr> <td>504 pedestal (structure)</td> <td><input type="checkbox"/></td> <td><input type="checkbox"/></td> <td><input type="checkbox"/></td> <td><input type="checkbox"/></td> <td><input type="checkbox"/></td> </tr> <tr> <td>505 boom valve without leaking</td> <td><input type="checkbox"/></td> <td><input type="checkbox"/></td> <td><input type="checkbox"/></td> <td><input type="checkbox"/></td> <td><input type="checkbox"/></td> </tr> <tr> <td>506 boom rest</td> <td><input type="checkbox"/></td> <td><input type="checkbox"/></td> <td><input type="checkbox"/></td> <td><input type="checkbox"/></td> <td><input type="checkbox"/></td> </tr> <tr> <td>507 transportation safety device</td> <td><input type="checkbox"/></td> <td><input type="checkbox"/></td> <td><input type="checkbox"/></td> <td><input type="checkbox"/></td> <td><input type="checkbox"/></td> </tr> <tr> <td>508 hydraulic line</td> <td><input type="checkbox"/></td> <td><input type="checkbox"/></td> <td><input type="checkbox"/></td> <td><input type="checkbox"/></td> <td><input type="checkbox"/></td> </tr> <tr> <td colspan="6"> </td> </tr> <tr> <td>600 slewing head with ball pivot</td> <td colspan="5"></td> </tr> <tr> <td>601 slewing head</td> <td><input type="checkbox"/></td> <td><input type="checkbox"/></td> <td><input type="checkbox"/></td> <td><input type="checkbox"/></td> <td><input type="checkbox"/></td> </tr> <tr> <td>602 ball pivot ring</td> <td><input type="checkbox"/></td> <td><input type="checkbox"/></td> <td><input type="checkbox"/></td> <td><input type="checkbox"/></td> <td><input type="checkbox"/></td> </tr> <tr> <td>603 mounting ball pivot ring</td> <td><input type="checkbox"/></td> <td><input type="checkbox"/></td> <td><input type="checkbox"/></td> <td><input type="checkbox"/></td> <td><input type="checkbox"/></td> </tr> <tr> <td>604 drive pinion</td> <td><input type="checkbox"/></td> <td><input type="checkbox"/></td> <td><input type="checkbox"/></td> <td><input type="checkbox"/></td> <td><input type="checkbox"/></td> </tr> </table>	406 slewing bearing	<input type="checkbox"/>	<input type="checkbox"/>	<input type="checkbox"/>	<input type="checkbox"/>	<input type="checkbox"/>	407 turn locking device	<input type="checkbox"/>	<input type="checkbox"/>	<input type="checkbox"/>	<input type="checkbox"/>	<input type="checkbox"/>	408 support safeguard	<input type="checkbox"/>	<input type="checkbox"/>	<input type="checkbox"/>	<input type="checkbox"/>	<input type="checkbox"/>	409 support plate	<input type="checkbox"/>	<input type="checkbox"/>	<input type="checkbox"/>	<input type="checkbox"/>	<input type="checkbox"/>	410 fixing of jack cylinder	<input type="checkbox"/>	<input type="checkbox"/>	<input type="checkbox"/>	<input type="checkbox"/>	<input type="checkbox"/>	411 jack cylinder	<input type="checkbox"/>	<input type="checkbox"/>	<input type="checkbox"/>	<input type="checkbox"/>	<input type="checkbox"/>	412 swing cylinder	<input type="checkbox"/>	<input type="checkbox"/>	<input type="checkbox"/>	<input type="checkbox"/>	<input type="checkbox"/>	413 telescopic cylinder	<input type="checkbox"/>	<input type="checkbox"/>	<input type="checkbox"/>	<input type="checkbox"/>	<input type="checkbox"/>	 						500 pedestal						501 pedestal mounting	<input type="checkbox"/>	<input type="checkbox"/>	<input type="checkbox"/>	<input type="checkbox"/>	<input type="checkbox"/>	502 sub frame	<input type="checkbox"/>	<input type="checkbox"/>	<input type="checkbox"/>	<input type="checkbox"/>	<input type="checkbox"/>	503 truck frame	<input type="checkbox"/>	<input type="checkbox"/>	<input type="checkbox"/>	<input type="checkbox"/>	<input type="checkbox"/>	504 pedestal (structure)	<input type="checkbox"/>	<input type="checkbox"/>	<input type="checkbox"/>	<input type="checkbox"/>	<input type="checkbox"/>	505 boom valve without leaking	<input type="checkbox"/>	<input type="checkbox"/>	<input type="checkbox"/>	<input type="checkbox"/>	<input type="checkbox"/>	506 boom rest	<input type="checkbox"/>	<input type="checkbox"/>	<input type="checkbox"/>	<input type="checkbox"/>	<input type="checkbox"/>	507 transportation safety device	<input type="checkbox"/>	<input type="checkbox"/>	<input type="checkbox"/>	<input type="checkbox"/>	<input type="checkbox"/>	508 hydraulic line	<input type="checkbox"/>	<input type="checkbox"/>	<input type="checkbox"/>	<input type="checkbox"/>	<input type="checkbox"/>	 						600 slewing head with ball pivot						601 slewing head	<input type="checkbox"/>	<input type="checkbox"/>	<input type="checkbox"/>	<input type="checkbox"/>	<input type="checkbox"/>	602 ball pivot ring	<input type="checkbox"/>	<input type="checkbox"/>	<input type="checkbox"/>	<input type="checkbox"/>	<input type="checkbox"/>	603 mounting ball pivot ring	<input type="checkbox"/>	<input type="checkbox"/>	<input type="checkbox"/>	<input type="checkbox"/>	<input type="checkbox"/>	604 drive pinion	<input type="checkbox"/>	<input type="checkbox"/>	<input type="checkbox"/>	<input type="checkbox"/>	<input type="checkbox"/>	<table border="0" style="width: 100%;"> <tr> <td style="width: 30%;">605 slewing drive mounting</td> <td style="width: 20%;"><input type="checkbox"/></td> <td style="width: 20%;"><input type="checkbox"/></td> <td style="width: 20%;"><input type="checkbox"/></td> <td style="width: 20%;"><input type="checkbox"/></td> <td style="width: 20%;"><input type="checkbox"/></td> </tr> <tr> <td>606 slewing stop device</td> <td><input type="checkbox"/></td> <td><input type="checkbox"/></td> <td><input type="checkbox"/></td> <td><input type="checkbox"/></td> <td><input type="checkbox"/></td> </tr> <tr> <td>607 slewing drive (tooth backlash)</td> <td><input type="checkbox"/></td> <td><input type="checkbox"/></td> <td><input type="checkbox"/></td> <td><input type="checkbox"/></td> <td><input type="checkbox"/></td> </tr> <tr> <td>608 slewing drive</td> <td><input type="checkbox"/></td> <td><input type="checkbox"/></td> <td><input type="checkbox"/></td> <td><input type="checkbox"/></td> <td><input type="checkbox"/></td> </tr> <tr> <td>609 brake function</td> <td><input type="checkbox"/></td> <td><input type="checkbox"/></td> <td><input type="checkbox"/></td> <td><input type="checkbox"/></td> <td><input type="checkbox"/></td> </tr> <tr> <td>610 speed</td> <td><input type="checkbox"/></td> <td><input type="checkbox"/></td> <td><input type="checkbox"/></td> <td><input type="checkbox"/></td> <td><input type="checkbox"/></td> </tr> <tr> <td>611 pressure setting</td> <td><input type="checkbox"/></td> <td><input type="checkbox"/></td> <td><input type="checkbox"/></td> <td><input type="checkbox"/></td> <td><input type="checkbox"/></td> </tr> <tr> <td>612 hydraulic lines</td> <td><input type="checkbox"/></td> <td><input type="checkbox"/></td> <td><input type="checkbox"/></td> <td><input type="checkbox"/></td> <td><input type="checkbox"/></td> </tr> <tr> <td colspan="6"> </td> </tr> <tr> <td>700 slewing head with slewing column</td> <td colspan="5"></td> </tr> <tr> <td>701 slewing head</td> <td><input type="checkbox"/></td> <td><input type="checkbox"/></td> <td><input type="checkbox"/></td> <td><input type="checkbox"/></td> <td><input type="checkbox"/></td> </tr> <tr> <td>702 slewing column bearing</td> <td><input type="checkbox"/></td> <td><input type="checkbox"/></td> <td><input type="checkbox"/></td> <td><input type="checkbox"/></td> <td><input type="checkbox"/></td> </tr> <tr> <td>703 slewing drive (tooth backlash)</td> <td><input type="checkbox"/></td> <td><input type="checkbox"/></td> <td><input type="checkbox"/></td> <td><input type="checkbox"/></td> <td><input type="checkbox"/></td> </tr> <tr> <td>704 speed</td> <td><input type="checkbox"/></td> <td><input type="checkbox"/></td> <td><input type="checkbox"/></td> <td><input type="checkbox"/></td> <td><input type="checkbox"/></td> </tr> <tr> <td>705 pressure settings</td> <td><input type="checkbox"/></td> <td><input type="checkbox"/></td> <td><input type="checkbox"/></td> <td><input type="checkbox"/></td> <td><input type="checkbox"/></td> </tr> <tr> <td>706 hydraulic lines</td> <td><input type="checkbox"/></td> <td><input type="checkbox"/></td> <td><input type="checkbox"/></td> <td><input type="checkbox"/></td> <td><input type="checkbox"/></td> </tr> <tr> <td>707 swivel cylinder</td> <td><input type="checkbox"/></td> <td><input type="checkbox"/></td> <td><input type="checkbox"/></td> <td><input type="checkbox"/></td> <td><input type="checkbox"/></td> </tr> </table>	605 slewing drive mounting	<input type="checkbox"/>	<input type="checkbox"/>	<input type="checkbox"/>	<input type="checkbox"/>	<input type="checkbox"/>	606 slewing stop device	<input type="checkbox"/>	<input type="checkbox"/>	<input type="checkbox"/>	<input type="checkbox"/>	<input type="checkbox"/>	607 slewing drive (tooth backlash)	<input type="checkbox"/>	<input type="checkbox"/>	<input type="checkbox"/>	<input type="checkbox"/>	<input type="checkbox"/>	608 slewing drive	<input type="checkbox"/>	<input type="checkbox"/>	<input type="checkbox"/>	<input type="checkbox"/>	<input type="checkbox"/>	609 brake function	<input type="checkbox"/>	<input type="checkbox"/>	<input type="checkbox"/>	<input type="checkbox"/>	<input type="checkbox"/>	610 speed	<input type="checkbox"/>	<input type="checkbox"/>	<input type="checkbox"/>	<input type="checkbox"/>	<input type="checkbox"/>	611 pressure setting	<input type="checkbox"/>	<input type="checkbox"/>	<input type="checkbox"/>	<input type="checkbox"/>	<input type="checkbox"/>	612 hydraulic lines	<input type="checkbox"/>	<input type="checkbox"/>	<input type="checkbox"/>	<input type="checkbox"/>	<input type="checkbox"/>	 						700 slewing head with slewing column						701 slewing head	<input type="checkbox"/>	<input type="checkbox"/>	<input type="checkbox"/>	<input type="checkbox"/>	<input type="checkbox"/>	702 slewing column bearing	<input type="checkbox"/>	<input type="checkbox"/>	<input type="checkbox"/>	<input type="checkbox"/>	<input type="checkbox"/>	703 slewing drive (tooth backlash)	<input type="checkbox"/>	<input type="checkbox"/>	<input type="checkbox"/>	<input type="checkbox"/>	<input type="checkbox"/>	704 speed	<input type="checkbox"/>	<input type="checkbox"/>	<input type="checkbox"/>	<input type="checkbox"/>	<input type="checkbox"/>	705 pressure settings	<input type="checkbox"/>	<input type="checkbox"/>	<input type="checkbox"/>	<input type="checkbox"/>	<input type="checkbox"/>	706 hydraulic lines	<input type="checkbox"/>	<input type="checkbox"/>	<input type="checkbox"/>	<input type="checkbox"/>	<input type="checkbox"/>	707 swivel cylinder	<input type="checkbox"/>	<input type="checkbox"/>	<input type="checkbox"/>	<input type="checkbox"/>	<input type="checkbox"/>
406 slewing bearing	<input type="checkbox"/>	<input type="checkbox"/>	<input type="checkbox"/>	<input type="checkbox"/>	<input type="checkbox"/>																																																																																																																																																																																																																																																		
407 turn locking device	<input type="checkbox"/>	<input type="checkbox"/>	<input type="checkbox"/>	<input type="checkbox"/>	<input type="checkbox"/>																																																																																																																																																																																																																																																		
408 support safeguard	<input type="checkbox"/>	<input type="checkbox"/>	<input type="checkbox"/>	<input type="checkbox"/>	<input type="checkbox"/>																																																																																																																																																																																																																																																		
409 support plate	<input type="checkbox"/>	<input type="checkbox"/>	<input type="checkbox"/>	<input type="checkbox"/>	<input type="checkbox"/>																																																																																																																																																																																																																																																		
410 fixing of jack cylinder	<input type="checkbox"/>	<input type="checkbox"/>	<input type="checkbox"/>	<input type="checkbox"/>	<input type="checkbox"/>																																																																																																																																																																																																																																																		
411 jack cylinder	<input type="checkbox"/>	<input type="checkbox"/>	<input type="checkbox"/>	<input type="checkbox"/>	<input type="checkbox"/>																																																																																																																																																																																																																																																		
412 swing cylinder	<input type="checkbox"/>	<input type="checkbox"/>	<input type="checkbox"/>	<input type="checkbox"/>	<input type="checkbox"/>																																																																																																																																																																																																																																																		
413 telescopic cylinder	<input type="checkbox"/>	<input type="checkbox"/>	<input type="checkbox"/>	<input type="checkbox"/>	<input type="checkbox"/>																																																																																																																																																																																																																																																		
500 pedestal																																																																																																																																																																																																																																																							
501 pedestal mounting	<input type="checkbox"/>	<input type="checkbox"/>	<input type="checkbox"/>	<input type="checkbox"/>	<input type="checkbox"/>																																																																																																																																																																																																																																																		
502 sub frame	<input type="checkbox"/>	<input type="checkbox"/>	<input type="checkbox"/>	<input type="checkbox"/>	<input type="checkbox"/>																																																																																																																																																																																																																																																		
503 truck frame	<input type="checkbox"/>	<input type="checkbox"/>	<input type="checkbox"/>	<input type="checkbox"/>	<input type="checkbox"/>																																																																																																																																																																																																																																																		
504 pedestal (structure)	<input type="checkbox"/>	<input type="checkbox"/>	<input type="checkbox"/>	<input type="checkbox"/>	<input type="checkbox"/>																																																																																																																																																																																																																																																		
505 boom valve without leaking	<input type="checkbox"/>	<input type="checkbox"/>	<input type="checkbox"/>	<input type="checkbox"/>	<input type="checkbox"/>																																																																																																																																																																																																																																																		
506 boom rest	<input type="checkbox"/>	<input type="checkbox"/>	<input type="checkbox"/>	<input type="checkbox"/>	<input type="checkbox"/>																																																																																																																																																																																																																																																		
507 transportation safety device	<input type="checkbox"/>	<input type="checkbox"/>	<input type="checkbox"/>	<input type="checkbox"/>	<input type="checkbox"/>																																																																																																																																																																																																																																																		
508 hydraulic line	<input type="checkbox"/>	<input type="checkbox"/>	<input type="checkbox"/>	<input type="checkbox"/>	<input type="checkbox"/>																																																																																																																																																																																																																																																		
600 slewing head with ball pivot																																																																																																																																																																																																																																																							
601 slewing head	<input type="checkbox"/>	<input type="checkbox"/>	<input type="checkbox"/>	<input type="checkbox"/>	<input type="checkbox"/>																																																																																																																																																																																																																																																		
602 ball pivot ring	<input type="checkbox"/>	<input type="checkbox"/>	<input type="checkbox"/>	<input type="checkbox"/>	<input type="checkbox"/>																																																																																																																																																																																																																																																		
603 mounting ball pivot ring	<input type="checkbox"/>	<input type="checkbox"/>	<input type="checkbox"/>	<input type="checkbox"/>	<input type="checkbox"/>																																																																																																																																																																																																																																																		
604 drive pinion	<input type="checkbox"/>	<input type="checkbox"/>	<input type="checkbox"/>	<input type="checkbox"/>	<input type="checkbox"/>																																																																																																																																																																																																																																																		
605 slewing drive mounting	<input type="checkbox"/>	<input type="checkbox"/>	<input type="checkbox"/>	<input type="checkbox"/>	<input type="checkbox"/>																																																																																																																																																																																																																																																		
606 slewing stop device	<input type="checkbox"/>	<input type="checkbox"/>	<input type="checkbox"/>	<input type="checkbox"/>	<input type="checkbox"/>																																																																																																																																																																																																																																																		
607 slewing drive (tooth backlash)	<input type="checkbox"/>	<input type="checkbox"/>	<input type="checkbox"/>	<input type="checkbox"/>	<input type="checkbox"/>																																																																																																																																																																																																																																																		
608 slewing drive	<input type="checkbox"/>	<input type="checkbox"/>	<input type="checkbox"/>	<input type="checkbox"/>	<input type="checkbox"/>																																																																																																																																																																																																																																																		
609 brake function	<input type="checkbox"/>	<input type="checkbox"/>	<input type="checkbox"/>	<input type="checkbox"/>	<input type="checkbox"/>																																																																																																																																																																																																																																																		
610 speed	<input type="checkbox"/>	<input type="checkbox"/>	<input type="checkbox"/>	<input type="checkbox"/>	<input type="checkbox"/>																																																																																																																																																																																																																																																		
611 pressure setting	<input type="checkbox"/>	<input type="checkbox"/>	<input type="checkbox"/>	<input type="checkbox"/>	<input type="checkbox"/>																																																																																																																																																																																																																																																		
612 hydraulic lines	<input type="checkbox"/>	<input type="checkbox"/>	<input type="checkbox"/>	<input type="checkbox"/>	<input type="checkbox"/>																																																																																																																																																																																																																																																		
700 slewing head with slewing column																																																																																																																																																																																																																																																							
701 slewing head	<input type="checkbox"/>	<input type="checkbox"/>	<input type="checkbox"/>	<input type="checkbox"/>	<input type="checkbox"/>																																																																																																																																																																																																																																																		
702 slewing column bearing	<input type="checkbox"/>	<input type="checkbox"/>	<input type="checkbox"/>	<input type="checkbox"/>	<input type="checkbox"/>																																																																																																																																																																																																																																																		
703 slewing drive (tooth backlash)	<input type="checkbox"/>	<input type="checkbox"/>	<input type="checkbox"/>	<input type="checkbox"/>	<input type="checkbox"/>																																																																																																																																																																																																																																																		
704 speed	<input type="checkbox"/>	<input type="checkbox"/>	<input type="checkbox"/>	<input type="checkbox"/>	<input type="checkbox"/>																																																																																																																																																																																																																																																		
705 pressure settings	<input type="checkbox"/>	<input type="checkbox"/>	<input type="checkbox"/>	<input type="checkbox"/>	<input type="checkbox"/>																																																																																																																																																																																																																																																		
706 hydraulic lines	<input type="checkbox"/>	<input type="checkbox"/>	<input type="checkbox"/>	<input type="checkbox"/>	<input type="checkbox"/>																																																																																																																																																																																																																																																		
707 swivel cylinder	<input type="checkbox"/>	<input type="checkbox"/>	<input type="checkbox"/>	<input type="checkbox"/>	<input type="checkbox"/>																																																																																																																																																																																																																																																		
Notes:																																																																																																																																																																																																																																																							

Inspection report for concrete booms

Inspection report Nr:	Boom type:	Machine-Nr:
-----------------------	------------	-------------

- Error code:**
- | | | | |
|------------------|---------------------|-------------------|--------------------------|
| 00 no objections | 08 corrosion | 16 porous | 24 deformation |
| 01 cracks | 09 lacquer failures | 17 burned through | 25 bear movement |
| 02 broken | 10 fraying | 18 not fixed | 26 lubrication |
| 03 leaky | 11 scratched | 19 clomp | 27 readability |
| 04 no function | 12 bendet | 20 sawing | 28 missing components |
| 05 low lifetime | 13 noises | 21 contaminated | 29 hydraulical |
| 06 worn out | 14 vibration | 22 bad contact | 30 electrical |
| 07 dirt | 15 miscellaneous | 23 temperature | 31 reinspection required |

<p>800 boom</p> <p>801 „Arm 1“ <input type="checkbox"/> <input type="checkbox"/> <input type="checkbox"/> <input type="checkbox"/> <input type="checkbox"/></p> <p>802 bracket conveying line <input type="checkbox"/> <input type="checkbox"/> <input type="checkbox"/> <input type="checkbox"/> <input type="checkbox"/></p> <p>803 Drop hook <input type="checkbox"/> <input type="checkbox"/> <input type="checkbox"/> <input type="checkbox"/> <input type="checkbox"/></p> <p>804 „Arm 2“ <input type="checkbox"/> <input type="checkbox"/> <input type="checkbox"/> <input type="checkbox"/> <input type="checkbox"/></p> <p>805 bracket conveying line <input type="checkbox"/> <input type="checkbox"/> <input type="checkbox"/> <input type="checkbox"/> <input type="checkbox"/></p> <p>806 Drop hook <input type="checkbox"/> <input type="checkbox"/> <input type="checkbox"/> <input type="checkbox"/> <input type="checkbox"/></p> <p>807 „Arm 3“ <input type="checkbox"/> <input type="checkbox"/> <input type="checkbox"/> <input type="checkbox"/> <input type="checkbox"/></p> <p>808 bracket conveying line <input type="checkbox"/> <input type="checkbox"/> <input type="checkbox"/> <input type="checkbox"/> <input type="checkbox"/></p> <p>809 guidance and interlock of the arm <input type="checkbox"/> <input type="checkbox"/> <input type="checkbox"/> <input type="checkbox"/> <input type="checkbox"/></p> <p>810 „Arm 4“ <input type="checkbox"/> <input type="checkbox"/> <input type="checkbox"/> <input type="checkbox"/> <input type="checkbox"/></p> <p>811 bracket conveying line <input type="checkbox"/> <input type="checkbox"/> <input type="checkbox"/> <input type="checkbox"/> <input type="checkbox"/></p> <p>812 guidance and interlock of the arm <input type="checkbox"/> <input type="checkbox"/> <input type="checkbox"/> <input type="checkbox"/> <input type="checkbox"/></p> <p>813 „Arm 5“ <input type="checkbox"/> <input type="checkbox"/> <input type="checkbox"/> <input type="checkbox"/> <input type="checkbox"/></p> <p>814 bracket conveying line <input type="checkbox"/> <input type="checkbox"/> <input type="checkbox"/> <input type="checkbox"/> <input type="checkbox"/></p> <p>815 guidance and interlock of the arm <input type="checkbox"/> <input type="checkbox"/> <input type="checkbox"/> <input type="checkbox"/> <input type="checkbox"/></p> <p>900 joint „A“</p> <p>901 boom <input type="checkbox"/> <input type="checkbox"/> <input type="checkbox"/> <input type="checkbox"/> <input type="checkbox"/></p> <p>902 link lever <input type="checkbox"/> <input type="checkbox"/> <input type="checkbox"/> <input type="checkbox"/> <input type="checkbox"/></p> <p>903 forcing rod <input type="checkbox"/> <input type="checkbox"/> <input type="checkbox"/> <input type="checkbox"/> <input type="checkbox"/></p> <p>904 pin <input type="checkbox"/> <input type="checkbox"/> <input type="checkbox"/> <input type="checkbox"/> <input type="checkbox"/></p> <p>905 cylinder <input type="checkbox"/> <input type="checkbox"/> <input type="checkbox"/> <input type="checkbox"/> <input type="checkbox"/></p>	<p>906 boom speed <input type="checkbox"/> <input type="checkbox"/> <input type="checkbox"/> <input type="checkbox"/> <input type="checkbox"/></p> <p>907 pressure settings <input type="checkbox"/> <input type="checkbox"/> <input type="checkbox"/> <input type="checkbox"/> <input type="checkbox"/></p> <p>908 hydraulic lines <input type="checkbox"/> <input type="checkbox"/> <input type="checkbox"/> <input type="checkbox"/> <input type="checkbox"/></p> <p>909 load holding valve (piston side) <input type="checkbox"/> <input type="checkbox"/> <input type="checkbox"/> <input type="checkbox"/> <input type="checkbox"/></p> <p>910 load holding valve (rod side) <input type="checkbox"/> <input type="checkbox"/> <input type="checkbox"/> <input type="checkbox"/> <input type="checkbox"/></p> <p>1000 joint „B“</p> <p>1001 boom <input type="checkbox"/> <input type="checkbox"/> <input type="checkbox"/> <input type="checkbox"/> <input type="checkbox"/></p> <p>1002 link lever <input type="checkbox"/> <input type="checkbox"/> <input type="checkbox"/> <input type="checkbox"/> <input type="checkbox"/></p> <p>1003 forcing rod <input type="checkbox"/> <input type="checkbox"/> <input type="checkbox"/> <input type="checkbox"/> <input type="checkbox"/></p> <p>1004 pin <input type="checkbox"/> <input type="checkbox"/> <input type="checkbox"/> <input type="checkbox"/> <input type="checkbox"/></p> <p>1005 cylinder <input type="checkbox"/> <input type="checkbox"/> <input type="checkbox"/> <input type="checkbox"/> <input type="checkbox"/></p> <p>1006 boom speed <input type="checkbox"/> <input type="checkbox"/> <input type="checkbox"/> <input type="checkbox"/> <input type="checkbox"/></p> <p>1007 pressure settings <input type="checkbox"/> <input type="checkbox"/> <input type="checkbox"/> <input type="checkbox"/> <input type="checkbox"/></p> <p>1008 hydraulic lines <input type="checkbox"/> <input type="checkbox"/> <input type="checkbox"/> <input type="checkbox"/> <input type="checkbox"/></p> <p>1009 load holding valve (piston side) <input type="checkbox"/> <input type="checkbox"/> <input type="checkbox"/> <input type="checkbox"/> <input type="checkbox"/></p> <p>1010 load holding valve (rod side) <input type="checkbox"/> <input type="checkbox"/> <input type="checkbox"/> <input type="checkbox"/> <input type="checkbox"/></p> <p>Notes:</p> <hr/> <hr/> <hr/> <hr/>
--	---

Inspection report for concrete booms

Inspection report Nr: _____ Boom type: _____ Machine-Nr: _____

Error code:

- | | | | |
|------------------|---------------------|-------------------|--------------------------|
| 00 no objections | 08 corrosion | 16 porous | 24 deformation |
| 01 cracks | 09 lacquer failures | 17 burned through | 25 bear movement |
| 02 broken | 10 fraying | 18 not fixed | 26 lubrication |
| 03 leaky | 11 scratched | 19 clomp | 27 readability |
| 04 no function | 12 bendet | 20 sawing | 28 missing components |
| 05 low lifetime | 13 noises | 21 contaminated | 29 hydraulical |
| 06 worn out | 14 vibration | 22 bad contact | 30 electrical |
| 07 dirt | 15 miscellaneous | 23 temperature | 31 reinspection required |

1100 joint "C"

- 1101 boom
- 1102 link lever
- 1103 forcing rod
- 1104 pin
- 1105 cylinder
- 1106 boom speed
- 1107 pressure settings
- 1108 hydraulic lines
- 1109 load holding valve (piston side)
- 1110 load holding valve (rod side)

1200 joint "D"

- 1201 boom
- 1202 link lever
- 1203 forcing rod
- 1204 pin
- 1205 cylinder
- 1206 boom speed
- 1207 pressure settings
- 1208 hydraulic lines
- 1209 load holding valve (piston side)
- 1210 load holding valve (rod side)

1300 joint „E“

- 1301 boom
- 1302 link lever
- 1303 forcing rod
- 1304 pin
- 1305 cylinder
- 1306 boom speed
- 1307 pressure settings
- 1308 hydraulic lines
- 1309 load holding valve (piston side)
- 1310 load holding valve (rod side)

1400 concrete delivery line

- 1401 assembly of delivery line DN
- 1402 end hose DN+Henght
- 1403 delivery line DN
- 1404 rotating joints of - delivery line
- 1405 locking pin of the coupling

Notes:

Inspection report for concrete booms

Page 5-5

Inspection report Nr: _____ Boom type: _____ Machine-Nr: _____

Error code:

- | | | | |
|------------------|---------------------|-------------------|--------------------------|
| 00 no objections | 08 corrosion | 16 porous | 24 deformation |
| 01 cracks | 09 lacquer failures | 17 burned through | 25 bear movement |
| 02 broken | 10 fraying | 18 not fixed | 26 lubrication |
| 03 leaky | 11 scratched | 19 clomp | 27 readability |
| 04 no function | 12 bendet | 20 sawing | 28 missing components |
| 05 low lifetime | 13 noises | 21 contaminated | 29 hydraulical |
| 06 worn out | 14 vibration | 22 bad contact | 30 electrical |
| 07 dirt | 15 miscellaneous | 23 temperature | 31 reinspection required |

1406 end hose safety device

1407 reducer

1408 gate elbow, elbow 6"

1500 hydraulic system and hydraulic valves

1501 Pressure relief valve

1502 pressure settings

1503 hydraulic lines

1504 hand operating-
(function)

1505 boom control valve

1506 hydraulic pump

1600 electric equipment

1601 remote control
(functions)

1602 emergency stop
(function)

1603 switch for outrigger
function

1604 switch for boom
function

1605 wiring harness

1606 central lubrication

1700 sticker sets

1701 safety hints

1702 description

1703 operating

1704 short operating
instruction

1705 sticker „don't use
the boom as crane“

1706 sticker „guideline
operating with boom-
and concrete pump“

1707 name plate

1708 sticker „danger
high voltage“

Competent inspector:

Date: _____

Name: _____

Signature: _____
(stamp)

Customer:

Signature: _____
(stamp)

Inspection report for concrete pump

Page 1-3

Inspection report Nr:	Machine-Nr:	Hours of operation:
		Concrete output m ³ :
Company:	Post code:	City:

NL	WV
----	----

Proof – Result of the tests

without defects	defects	reinspection required	shut down
<input type="checkbox"/>	<input type="checkbox"/>	<input type="checkbox"/>	<input type="checkbox"/>

Reinspection until date:

Error code:

- | | | | |
|------------------|---------------------|-------------------|--------------------------|
| 00 no objections | 08 corrosion | 16 porous | 24 deformation |
| 01 cracks | 09 lacquer failures | 17 burned through | 25 bear movement |
| 02 broken | 10 fraying | 18 not fixed | 26 lubrication |
| 03 leaky | 11 scratched | 19 clomp | 27 readability |
| 04 no fuction | 12 bendet | 20 sawing | 28 missing components |
| 05 low livetime | 13 noises | 21 contaminated | 29 hydraulical |
| 06 worn out | 14 vibration | 22 bad contact | 30 electrical |
| 07 dirt | 15 miscellaneous | 23 temperature | 31 reinspection required |

2000 documents

2001 operating manual	<input type="checkbox"/>	<input type="checkbox"/>	<input type="checkbox"/>	<input type="checkbox"/>	<input type="checkbox"/>
2002 spare parts list	<input type="checkbox"/>	<input type="checkbox"/>	<input type="checkbox"/>	<input type="checkbox"/>	<input type="checkbox"/>
2100 drive assembly					
2101 coupling and flange	<input type="checkbox"/>	<input type="checkbox"/>	<input type="checkbox"/>	<input type="checkbox"/>	<input type="checkbox"/>
2200 gear box	<input type="checkbox"/>	<input type="checkbox"/>	<input type="checkbox"/>	<input type="checkbox"/>	<input type="checkbox"/>
2300 hydraulic pump (main)	<input type="checkbox"/>	<input type="checkbox"/>	<input type="checkbox"/>	<input type="checkbox"/>	<input type="checkbox"/>
2400 oil-tank	<input type="checkbox"/>	<input type="checkbox"/>	<input type="checkbox"/>	<input type="checkbox"/>	<input type="checkbox"/>
2500 drive shaft	<input type="checkbox"/>	<input type="checkbox"/>	<input type="checkbox"/>	<input type="checkbox"/>	<input type="checkbox"/>

2700 hydraulic control system

2701 pressure relief valve	<input type="checkbox"/>	<input type="checkbox"/>	<input type="checkbox"/>	<input type="checkbox"/>	<input type="checkbox"/>
2702 pressure setting	<input type="checkbox"/>	<input type="checkbox"/>	<input type="checkbox"/>	<input type="checkbox"/>	<input type="checkbox"/>
2703 hydraulic line	<input type="checkbox"/>	<input type="checkbox"/>	<input type="checkbox"/>	<input type="checkbox"/>	<input type="checkbox"/>
2704 mechanical operation by hand	<input type="checkbox"/>	<input type="checkbox"/>	<input type="checkbox"/>	<input type="checkbox"/>	<input type="checkbox"/>
2800 oil –cooler	<input type="checkbox"/>	<input type="checkbox"/>	<input type="checkbox"/>	<input type="checkbox"/>	<input type="checkbox"/>
2900 accumulator	<input type="checkbox"/>	<input type="checkbox"/>	<input type="checkbox"/>	<input type="checkbox"/>	<input type="checkbox"/>
2901 proofs of the required tests according to accumulator regulation	<input type="checkbox"/>	<input type="checkbox"/>	<input type="checkbox"/>	<input type="checkbox"/>	<input type="checkbox"/>
2902 pressure gauge	<input type="checkbox"/>	<input type="checkbox"/>	<input type="checkbox"/>	<input type="checkbox"/>	<input type="checkbox"/>

Notes:

Inspection report for concrete pump

Inspection report Nr: _____ Machine-Nr: _____

Error code:

- | | | | |
|------------------|---------------------|-------------------|--------------------------|
| 00 no objections | 08 corrosion | 16 porous | 24 deformation |
| 01 cracks | 09 lacquer failures | 17 burned through | 25 bear movement |
| 02 broken | 10 fraying | 18 not fixed | 26 lubrication |
| 03 leaky | 11 scratched | 19 clump | 27 readability |
| 04 no function | 12 bendet | 20 sawing | 28 missing components |
| 05 low lifetime | 13 noises | 21 contaminated | 29 hydraulical |
| 06 worn out | 14 vibration | 22 bad contact | 30 electrical |
| 07 dirt | 15 miscellaneous | 23 temperature | 31 reinspection required |

<p>3000 central lubrication <input type="checkbox"/> <input type="checkbox"/> <input type="checkbox"/> <input type="checkbox"/> <input type="checkbox"/></p> <p>3100 hydraulic motor <input type="checkbox"/> <input type="checkbox"/> <input type="checkbox"/> <input type="checkbox"/> <input type="checkbox"/></p> <p>3200 hydraulic lines <input type="checkbox"/> <input type="checkbox"/> <input type="checkbox"/> <input type="checkbox"/> <input type="checkbox"/></p> <p>3300 air compressor <input type="checkbox"/> <input type="checkbox"/> <input type="checkbox"/> <input type="checkbox"/> <input type="checkbox"/></p> <p>3400 control panel <input type="checkbox"/> <input type="checkbox"/> <input type="checkbox"/> <input type="checkbox"/> <input type="checkbox"/></p> <p>3500 concrete pump <input type="checkbox"/> <input type="checkbox"/> <input type="checkbox"/> <input type="checkbox"/> <input type="checkbox"/></p> <p>3700 S-valve <input type="checkbox"/> <input type="checkbox"/> <input type="checkbox"/> <input type="checkbox"/> <input type="checkbox"/></p> <p>3800 hopper <input type="checkbox"/> <input type="checkbox"/> <input type="checkbox"/> <input type="checkbox"/> <input type="checkbox"/></p> <p>4100 sub frame <input type="checkbox"/> <input type="checkbox"/> <input type="checkbox"/> <input type="checkbox"/> <input type="checkbox"/></p> <p>4200 water tank <input type="checkbox"/> <input type="checkbox"/> <input type="checkbox"/> <input type="checkbox"/> <input type="checkbox"/></p> <p>4300 axle <input type="checkbox"/> <input type="checkbox"/> <input type="checkbox"/> <input type="checkbox"/> <input type="checkbox"/></p> <p>4400 water pump <input type="checkbox"/> <input type="checkbox"/> <input type="checkbox"/> <input type="checkbox"/> <input type="checkbox"/></p> <p>4500 vibrator <input type="checkbox"/> <input type="checkbox"/> <input type="checkbox"/> <input type="checkbox"/> <input type="checkbox"/></p>	<p>4600 safety guards, equipment</p> <p>4601 stair <input type="checkbox"/> <input type="checkbox"/> <input type="checkbox"/> <input type="checkbox"/> <input type="checkbox"/></p> <p>4602 safety for stair <input type="checkbox"/> <input type="checkbox"/> <input type="checkbox"/> <input type="checkbox"/> <input type="checkbox"/></p> <p>4603 handrail <input type="checkbox"/> <input type="checkbox"/> <input type="checkbox"/> <input type="checkbox"/> <input type="checkbox"/></p> <p>4604 hopper grid (fixing device) <input type="checkbox"/> <input type="checkbox"/> <input type="checkbox"/> <input type="checkbox"/> <input type="checkbox"/></p> <p>4606 distance of grid rods <input type="checkbox"/> <input type="checkbox"/> <input type="checkbox"/> <input type="checkbox"/> <input type="checkbox"/></p> <p>4607 distance from grid to agitator <input type="checkbox"/> <input type="checkbox"/> <input type="checkbox"/> <input type="checkbox"/> <input type="checkbox"/></p> <p>4609 agitator have to stop if grid is open <input type="checkbox"/> <input type="checkbox"/> <input type="checkbox"/> <input type="checkbox"/> <input type="checkbox"/></p> <p>4610 accumulator have to dump if grid is open <input type="checkbox"/> <input type="checkbox"/> <input type="checkbox"/> <input type="checkbox"/> <input type="checkbox"/></p> <p>4612 cleaning flap hopper <input type="checkbox"/> <input type="checkbox"/> <input type="checkbox"/> <input type="checkbox"/> <input type="checkbox"/></p> <p>4613 safety grid into water box <input type="checkbox"/> <input type="checkbox"/> <input type="checkbox"/> <input type="checkbox"/> <input type="checkbox"/></p>
--	---

Notes:

Inspection report for concrete pump

Inspection report Nr: _____ Machine-Nr: _____

Error code:

- | | | | |
|------------------|---------------------|-------------------|--------------------------|
| 00 no objections | 08 corrosion | 16 porous | 24 deformation |
| 01 cracks | 09 lacquer failures | 17 burned through | 25 bear movement |
| 02 broken | 10 fraying | 18 not fixed | 26 lubrication |
| 03 leaky | 11 scratched | 19 clomp | 27 readability |
| 04 no function | 12 bendet | 20 sawing | 28 missing components |
| 05 low lifetime | 13 noises | 21 contaminated | 29 hydraulical |
| 06 worn out | 14 vibration | 22 bad contact | 30 electrical |
| 07 dirt | 15 miscellaneous | 23 temperature | 31 reinspection required |

4614 cover for rotating wave

4616 cover for chains

4617 cover for shift cylinder

4618 cover for moving parts

4619 cover for the exhaust pipe

4700 electrical system

4701 function of actuator component

4702 emergency stop function

4703 ground connections

4704 cables and wiring harness

4705 temperature switch

4800 outrigger - system

4801 transportation lock

4802 locking device

4803 backing plate

4804 jack cylinder connections

4805 pressure adjustment of jack cylinder

4900 miscellaneous

4901 additional assembled part from operator

4902 changes through operator

Competent inspector:

Date:

Name:

Signature:
(stamp)

Customer:

Signature:
(stamp)

This test report is filed into the test book

Inspection report for concrete booms

Inspection report -Nr:	Machine-Nr	Hours of operation:
Company:	Post code:	Concrete output m ³ :
Boom Type:	Boom Nr.	NL WV

Proof - Result of the Tests

without defects	defects	reinspection required	shut down
<input type="checkbox"/>	<input type="checkbox"/>	<input type="checkbox"/>	<input type="checkbox"/>

Reinspection until date:.....

Error code:

- | | | | |
|------------------|---------------------|-------------------|--------------------------|
| 00 no objections | 08 corrosion | 16 porous | 24 deformation |
| 01 cracks | 09 lacquer failures | 17 burned through | 25 bear movement |
| 02 broken | 10 fraying | 18 not fixed | 26 lubrication |
| 03 leaky | 11 scratched | 19 clomp | 27 readability |
| 04 no function | 12 bendet | 20 sawing | 28 missing components |
| 05 low lifetime | 13 noises | 21 contaminated | 29 hydraulical |
| 06 worn out | 14 vibration | 22 bad contact | 30 electrical |
| 07 dirt | 15 miscellaneous | 23 temperature | 31 reinspection required |

<p>100 documents</p> <p>101 instruction manual <input type="checkbox"/> <input type="checkbox"/> <input type="checkbox"/> <input type="checkbox"/> <input type="checkbox"/></p> <p>102 spare parts list <input type="checkbox"/> <input type="checkbox"/> <input type="checkbox"/> <input type="checkbox"/> <input type="checkbox"/></p> <p>200 sub frame</p> <p>201 frame connection cpl. <input type="checkbox"/> <input type="checkbox"/> <input type="checkbox"/> <input type="checkbox"/> <input type="checkbox"/></p> <p>300 outrigger front R+L</p> <p>301 transportation safety device <input type="checkbox"/> <input type="checkbox"/> <input type="checkbox"/> <input type="checkbox"/> <input type="checkbox"/></p> <p>302 outrigger <input type="checkbox"/> <input type="checkbox"/> <input type="checkbox"/> <input type="checkbox"/> <input type="checkbox"/></p> <p>303 extension box <input type="checkbox"/> <input type="checkbox"/> <input type="checkbox"/> <input type="checkbox"/> <input type="checkbox"/></p> <p>304 locking device <input type="checkbox"/> <input type="checkbox"/> <input type="checkbox"/> <input type="checkbox"/> <input type="checkbox"/></p> <p>305 slewing bearing <input type="checkbox"/> <input type="checkbox"/> <input type="checkbox"/> <input type="checkbox"/> <input type="checkbox"/></p> <p>306 turn locking device <input type="checkbox"/> <input type="checkbox"/> <input type="checkbox"/> <input type="checkbox"/> <input type="checkbox"/></p> <p>307 support safeguard <input type="checkbox"/> <input type="checkbox"/> <input type="checkbox"/> <input type="checkbox"/> <input type="checkbox"/></p> <p>308 support plate <input type="checkbox"/> <input type="checkbox"/> <input type="checkbox"/> <input type="checkbox"/> <input type="checkbox"/></p> <p>309 fixing of jack cylinder <input type="checkbox"/> <input type="checkbox"/> <input type="checkbox"/> <input type="checkbox"/> <input type="checkbox"/></p> <p>310 jack cylinder <input type="checkbox"/> <input type="checkbox"/> <input type="checkbox"/> <input type="checkbox"/> <input type="checkbox"/></p>	<p>311 swing cylinder <input type="checkbox"/> <input type="checkbox"/> <input type="checkbox"/> <input type="checkbox"/> <input type="checkbox"/></p> <p>312 telescopic-cylinder <input type="checkbox"/> <input type="checkbox"/> <input type="checkbox"/> <input type="checkbox"/> <input type="checkbox"/></p> <p>313 pressure adjustment <input type="checkbox"/> <input type="checkbox"/> <input type="checkbox"/> <input type="checkbox"/> <input type="checkbox"/></p> <p>400 outrigger rear L+R</p> <p>401 transportation safety device <input type="checkbox"/> <input type="checkbox"/> <input type="checkbox"/> <input type="checkbox"/> <input type="checkbox"/></p> <p>402 outrigger <input type="checkbox"/> <input type="checkbox"/> <input type="checkbox"/> <input type="checkbox"/> <input type="checkbox"/></p> <p>403 extension box <input type="checkbox"/> <input type="checkbox"/> <input type="checkbox"/> <input type="checkbox"/> <input type="checkbox"/></p> <p>405 locking device <input type="checkbox"/> <input type="checkbox"/> <input type="checkbox"/> <input type="checkbox"/> <input type="checkbox"/></p> <p>Notes:</p> <hr/> <hr/> <hr/> <hr/> <hr/> <hr/>
--	---

Inspection report for concrete booms

Inspection report Nr: _____ Boom type: _____ Machine-Nr: _____

- | | | | |
|--------------------|---------------------|-------------------|--------------------------|
| Error code: | | | |
| 00 no objections | 08 corrosion | 16 porous | 24 deformation |
| 01 cracks | 09 lacquer failures | 17 burned through | 25 bear movement |
| 02 broken | 10 fraying | 18 not fixed | 26 lubrication |
| 03 leaky | 11 scratched | 19 clump | 27 readability |
| 04 no function | 12 bendet | 20 sawing | 28 missing components |
| 05 low lifetime | 13 noises | 21 contaminated | 29 hydraulic |
| 06 worn out | 14 vibration | 22 bad contact | 30 electrical |
| 07 dirt | 15 miscellaneous | 23 temperature | 31 reinspection required |

<p>406 slewing bearing <input type="checkbox"/> <input type="checkbox"/> <input type="checkbox"/> <input type="checkbox"/> <input type="checkbox"/></p> <p>407 turn locking device <input type="checkbox"/> <input type="checkbox"/> <input type="checkbox"/> <input type="checkbox"/> <input type="checkbox"/></p> <p>408 support safeguard <input type="checkbox"/> <input type="checkbox"/> <input type="checkbox"/> <input type="checkbox"/> <input type="checkbox"/></p> <p>409 support plate <input type="checkbox"/> <input type="checkbox"/> <input type="checkbox"/> <input type="checkbox"/> <input type="checkbox"/></p> <p>410 fixing of jack cylinder <input type="checkbox"/> <input type="checkbox"/> <input type="checkbox"/> <input type="checkbox"/> <input type="checkbox"/></p> <p>411 jack cylinder <input type="checkbox"/> <input type="checkbox"/> <input type="checkbox"/> <input type="checkbox"/> <input type="checkbox"/></p> <p>412 swing cylinder <input type="checkbox"/> <input type="checkbox"/> <input type="checkbox"/> <input type="checkbox"/> <input type="checkbox"/></p> <p>413 telescopic cylinder <input type="checkbox"/> <input type="checkbox"/> <input type="checkbox"/> <input type="checkbox"/> <input type="checkbox"/></p> <p>500 pedestal</p> <p>501 pedestal mounting <input type="checkbox"/> <input type="checkbox"/> <input type="checkbox"/> <input type="checkbox"/> <input type="checkbox"/></p> <p>502 sub frame <input type="checkbox"/> <input type="checkbox"/> <input type="checkbox"/> <input type="checkbox"/> <input type="checkbox"/></p> <p>503 truck frame <input type="checkbox"/> <input type="checkbox"/> <input type="checkbox"/> <input type="checkbox"/> <input type="checkbox"/></p> <p>504 pedestal (structure) <input type="checkbox"/> <input type="checkbox"/> <input type="checkbox"/> <input type="checkbox"/> <input type="checkbox"/></p> <p>505 boom valve without leaking <input type="checkbox"/> <input type="checkbox"/> <input type="checkbox"/> <input type="checkbox"/> <input type="checkbox"/></p> <p>506 boom rest <input type="checkbox"/> <input type="checkbox"/> <input type="checkbox"/> <input type="checkbox"/> <input type="checkbox"/></p> <p>507 transportation safety device <input type="checkbox"/> <input type="checkbox"/> <input type="checkbox"/> <input type="checkbox"/> <input type="checkbox"/></p> <p>508 hydraulic line <input type="checkbox"/> <input type="checkbox"/> <input type="checkbox"/> <input type="checkbox"/> <input type="checkbox"/></p> <p>600 slewing head with ball pivot</p> <p>601 slewing head <input type="checkbox"/> <input type="checkbox"/> <input type="checkbox"/> <input type="checkbox"/> <input type="checkbox"/></p> <p>602 ball pivot ring <input type="checkbox"/> <input type="checkbox"/> <input type="checkbox"/> <input type="checkbox"/> <input type="checkbox"/></p> <p>603 mounting ball pivot ring <input type="checkbox"/> <input type="checkbox"/> <input type="checkbox"/> <input type="checkbox"/> <input type="checkbox"/></p> <p>604 drive pinion <input type="checkbox"/> <input type="checkbox"/> <input type="checkbox"/> <input type="checkbox"/> <input type="checkbox"/></p>	<p>605 slewing drive mounting <input type="checkbox"/> <input type="checkbox"/> <input type="checkbox"/> <input type="checkbox"/> <input type="checkbox"/></p> <p>606 slewing stop device <input type="checkbox"/> <input type="checkbox"/> <input type="checkbox"/> <input type="checkbox"/> <input type="checkbox"/></p> <p>607 slewing drive (tooth backlash) <input type="checkbox"/> <input type="checkbox"/> <input type="checkbox"/> <input type="checkbox"/> <input type="checkbox"/></p> <p>608 slewing drive <input type="checkbox"/> <input type="checkbox"/> <input type="checkbox"/> <input type="checkbox"/> <input type="checkbox"/></p> <p>609 brake function <input type="checkbox"/> <input type="checkbox"/> <input type="checkbox"/> <input type="checkbox"/> <input type="checkbox"/></p> <p>610 speed <input type="checkbox"/> <input type="checkbox"/> <input type="checkbox"/> <input type="checkbox"/> <input type="checkbox"/></p> <p>611 pressure setting <input type="checkbox"/> <input type="checkbox"/> <input type="checkbox"/> <input type="checkbox"/> <input type="checkbox"/></p> <p>612 hydraulic lines <input type="checkbox"/> <input type="checkbox"/> <input type="checkbox"/> <input type="checkbox"/> <input type="checkbox"/></p> <p>700 slewing head with slewing column</p> <p>701 slewing head <input type="checkbox"/> <input type="checkbox"/> <input type="checkbox"/> <input type="checkbox"/> <input type="checkbox"/></p> <p>702 slewing column bearing <input type="checkbox"/> <input type="checkbox"/> <input type="checkbox"/> <input type="checkbox"/> <input type="checkbox"/></p> <p>703 slewing drive (tooth backlash) <input type="checkbox"/> <input type="checkbox"/> <input type="checkbox"/> <input type="checkbox"/> <input type="checkbox"/></p> <p>704 speed <input type="checkbox"/> <input type="checkbox"/> <input type="checkbox"/> <input type="checkbox"/> <input type="checkbox"/></p> <p>705 pressure settings <input type="checkbox"/> <input type="checkbox"/> <input type="checkbox"/> <input type="checkbox"/> <input type="checkbox"/></p> <p>706 hydraulic lines <input type="checkbox"/> <input type="checkbox"/> <input type="checkbox"/> <input type="checkbox"/> <input type="checkbox"/></p> <p>707 swivel cylinder <input type="checkbox"/> <input type="checkbox"/> <input type="checkbox"/> <input type="checkbox"/> <input type="checkbox"/></p> <p>Notes:</p> <hr/> <hr/> <hr/> <hr/>
---	---

Inspection report for concrete booms

Inspection report Nr:

Boom type:

Machine-Nr:

Error code:

00 no objections	08 corrosion	16 porous	24 deformation
01 cracks	09 lacquer failures	17 burned through	25 bear movement
02 broken	10 fraying	18 not fixed	26 lubrication
03 leaky	11 scratched	19 clomp	27 readability
04 no function	12 bendet	20 sawing	28 missing components
05 low lifetime	13 noises	21 contaminated	29 hydraulical
06 worn out	14 vibration	22 bad contact	30 electrical
07 dirt	15 miscellaneous	23 temperature	31 reinspection required

<p>800 boom</p> <p>801 „Arm 1“ <input type="checkbox"/> <input type="checkbox"/> <input type="checkbox"/> <input type="checkbox"/> <input type="checkbox"/></p> <p>802 bracket conveying line <input type="checkbox"/> <input type="checkbox"/> <input type="checkbox"/> <input type="checkbox"/> <input type="checkbox"/></p> <p>803 Drop hook <input type="checkbox"/> <input type="checkbox"/> <input type="checkbox"/> <input type="checkbox"/> <input type="checkbox"/></p> <p>804 „Arm 2“ <input type="checkbox"/> <input type="checkbox"/> <input type="checkbox"/> <input type="checkbox"/> <input type="checkbox"/></p> <p>805 bracket conveying line <input type="checkbox"/> <input type="checkbox"/> <input type="checkbox"/> <input type="checkbox"/> <input type="checkbox"/></p> <p>806 Drop hook <input type="checkbox"/> <input type="checkbox"/> <input type="checkbox"/> <input type="checkbox"/> <input type="checkbox"/></p> <p>807 „Arm 3“ <input type="checkbox"/> <input type="checkbox"/> <input type="checkbox"/> <input type="checkbox"/> <input type="checkbox"/></p> <p>808 bracket conveying line <input type="checkbox"/> <input type="checkbox"/> <input type="checkbox"/> <input type="checkbox"/> <input type="checkbox"/></p> <p>809 guidance and interlock of the arm <input type="checkbox"/> <input type="checkbox"/> <input type="checkbox"/> <input type="checkbox"/> <input type="checkbox"/></p> <p>810 „Arm 4“ <input type="checkbox"/> <input type="checkbox"/> <input type="checkbox"/> <input type="checkbox"/> <input type="checkbox"/></p> <p>811 bracket conveying line <input type="checkbox"/> <input type="checkbox"/> <input type="checkbox"/> <input type="checkbox"/> <input type="checkbox"/></p> <p>812 guidance and interlock of the arm <input type="checkbox"/> <input type="checkbox"/> <input type="checkbox"/> <input type="checkbox"/> <input type="checkbox"/></p> <p>813 „Arm 5“ <input type="checkbox"/> <input type="checkbox"/> <input type="checkbox"/> <input type="checkbox"/> <input type="checkbox"/></p> <p>814 bracket conveying line <input type="checkbox"/> <input type="checkbox"/> <input type="checkbox"/> <input type="checkbox"/> <input type="checkbox"/></p> <p>815 guidance and interlock of the arm <input type="checkbox"/> <input type="checkbox"/> <input type="checkbox"/> <input type="checkbox"/> <input type="checkbox"/></p> <p>900 joint „A“</p> <p>901 boom <input type="checkbox"/> <input type="checkbox"/> <input type="checkbox"/> <input type="checkbox"/> <input type="checkbox"/></p> <p>902 link lever <input type="checkbox"/> <input type="checkbox"/> <input type="checkbox"/> <input type="checkbox"/> <input type="checkbox"/></p> <p>903 forcing rod <input type="checkbox"/> <input type="checkbox"/> <input type="checkbox"/> <input type="checkbox"/> <input type="checkbox"/></p> <p>904 pin <input type="checkbox"/> <input type="checkbox"/> <input type="checkbox"/> <input type="checkbox"/> <input type="checkbox"/></p> <p>905 cylinder <input type="checkbox"/> <input type="checkbox"/> <input type="checkbox"/> <input type="checkbox"/> <input type="checkbox"/></p>	<p>906 boom speed <input type="checkbox"/> <input type="checkbox"/> <input type="checkbox"/> <input type="checkbox"/> <input type="checkbox"/></p> <p>907 pressure settings <input type="checkbox"/> <input type="checkbox"/> <input type="checkbox"/> <input type="checkbox"/> <input type="checkbox"/></p> <p>908 hydraulic lines <input type="checkbox"/> <input type="checkbox"/> <input type="checkbox"/> <input type="checkbox"/> <input type="checkbox"/></p> <p>909 load holding valve (piston side) <input type="checkbox"/> <input type="checkbox"/> <input type="checkbox"/> <input type="checkbox"/> <input type="checkbox"/></p> <p>910 load holding valve (rod side) <input type="checkbox"/> <input type="checkbox"/> <input type="checkbox"/> <input type="checkbox"/> <input type="checkbox"/></p> <p>1000 joint „B“</p> <p>1001 boom <input type="checkbox"/> <input type="checkbox"/> <input type="checkbox"/> <input type="checkbox"/> <input type="checkbox"/></p> <p>1002 link lever <input type="checkbox"/> <input type="checkbox"/> <input type="checkbox"/> <input type="checkbox"/> <input type="checkbox"/></p> <p>1003 forcing rod <input type="checkbox"/> <input type="checkbox"/> <input type="checkbox"/> <input type="checkbox"/> <input type="checkbox"/></p> <p>1004 pin <input type="checkbox"/> <input type="checkbox"/> <input type="checkbox"/> <input type="checkbox"/> <input type="checkbox"/></p> <p>1005 cylinder <input type="checkbox"/> <input type="checkbox"/> <input type="checkbox"/> <input type="checkbox"/> <input type="checkbox"/></p> <p>1006 boom speed <input type="checkbox"/> <input type="checkbox"/> <input type="checkbox"/> <input type="checkbox"/> <input type="checkbox"/></p> <p>1007 pressure settings <input type="checkbox"/> <input type="checkbox"/> <input type="checkbox"/> <input type="checkbox"/> <input type="checkbox"/></p> <p>1008 hydraulic lines <input type="checkbox"/> <input type="checkbox"/> <input type="checkbox"/> <input type="checkbox"/> <input type="checkbox"/></p> <p>1009 load holding valve (piston side) <input type="checkbox"/> <input type="checkbox"/> <input type="checkbox"/> <input type="checkbox"/> <input type="checkbox"/></p> <p>1010 load holding valve (rod side) <input type="checkbox"/> <input type="checkbox"/> <input type="checkbox"/> <input type="checkbox"/> <input type="checkbox"/></p> <p>Notes:</p> <hr/> <hr/> <hr/> <hr/>
--	---

Inspection report for concrete booms

Inspection report Nr: _____ Boom type: _____ Machine-Nr: _____

Error code:			
00 no objections	08 corrosion	16 porous	24 deformation
01 cracks	09 lacquer failures	17 burned through	25 bear movement
02 broken	10 fraying	18 not fixed	26 lubrication
03 leaky	11 scratched	19 clomp	27 readability
04 no function	12 bendet	20 sawing	28 missing components
05 low lifetime	13 noises	21 contaminated	29 hydraulical
06 worn out	14 vibration	22 bad contact	30 electrical
07 dirt	15 miscellaneous	23 temperature	31 reinspection required

<p>1100 joint "C"</p> <p>1101 boom <input type="checkbox"/> <input type="checkbox"/> <input type="checkbox"/> <input type="checkbox"/> <input type="checkbox"/></p> <p>1102 link lever <input type="checkbox"/> <input type="checkbox"/> <input type="checkbox"/> <input type="checkbox"/> <input type="checkbox"/></p> <p>1103 forcing rod <input type="checkbox"/> <input type="checkbox"/> <input type="checkbox"/> <input type="checkbox"/> <input type="checkbox"/></p> <p>1104 pin <input type="checkbox"/> <input type="checkbox"/> <input type="checkbox"/> <input type="checkbox"/> <input type="checkbox"/></p> <p>1105 cylinder <input type="checkbox"/> <input type="checkbox"/> <input type="checkbox"/> <input type="checkbox"/> <input type="checkbox"/></p> <p>1106 boom speed <input type="checkbox"/> <input type="checkbox"/> <input type="checkbox"/> <input type="checkbox"/> <input type="checkbox"/></p> <p>1107 pressure settings <input type="checkbox"/> <input type="checkbox"/> <input type="checkbox"/> <input type="checkbox"/> <input type="checkbox"/></p> <p>1108 hydraulic lines <input type="checkbox"/> <input type="checkbox"/> <input type="checkbox"/> <input type="checkbox"/> <input type="checkbox"/></p> <p>1109 load holding valve (piston side) <input type="checkbox"/> <input type="checkbox"/> <input type="checkbox"/> <input type="checkbox"/> <input type="checkbox"/></p> <p>1110 load holding valve (rod side) <input type="checkbox"/> <input type="checkbox"/> <input type="checkbox"/> <input type="checkbox"/> <input type="checkbox"/></p> <p>1200 joint "D"</p> <p>1201 boom <input type="checkbox"/> <input type="checkbox"/> <input type="checkbox"/> <input type="checkbox"/> <input type="checkbox"/></p> <p>1202 link lever <input type="checkbox"/> <input type="checkbox"/> <input type="checkbox"/> <input type="checkbox"/> <input type="checkbox"/></p> <p>1203 forcing rod <input type="checkbox"/> <input type="checkbox"/> <input type="checkbox"/> <input type="checkbox"/> <input type="checkbox"/></p> <p>1204 pin <input type="checkbox"/> <input type="checkbox"/> <input type="checkbox"/> <input type="checkbox"/> <input type="checkbox"/></p> <p>1205 cylinder <input type="checkbox"/> <input type="checkbox"/> <input type="checkbox"/> <input type="checkbox"/> <input type="checkbox"/></p> <p>1206 boom speed <input type="checkbox"/> <input type="checkbox"/> <input type="checkbox"/> <input type="checkbox"/> <input type="checkbox"/></p> <p>1207 pressure settings <input type="checkbox"/> <input type="checkbox"/> <input type="checkbox"/> <input type="checkbox"/> <input type="checkbox"/></p> <p>1208 hydraulic lines <input type="checkbox"/> <input type="checkbox"/> <input type="checkbox"/> <input type="checkbox"/> <input type="checkbox"/></p> <p>1209 load holding valve (piston side) <input type="checkbox"/> <input type="checkbox"/> <input type="checkbox"/> <input type="checkbox"/> <input type="checkbox"/></p> <p>1210 load holding valve (rod side) <input type="checkbox"/> <input type="checkbox"/> <input type="checkbox"/> <input type="checkbox"/> <input type="checkbox"/></p>	<p>1300 joint „E“</p> <p>1301 boom <input type="checkbox"/> <input type="checkbox"/> <input type="checkbox"/> <input type="checkbox"/> <input type="checkbox"/></p> <p>1302 link lever <input type="checkbox"/> <input type="checkbox"/> <input type="checkbox"/> <input type="checkbox"/> <input type="checkbox"/></p> <p>1303 forcing rod <input type="checkbox"/> <input type="checkbox"/> <input type="checkbox"/> <input type="checkbox"/> <input type="checkbox"/></p> <p>1304 pin <input type="checkbox"/> <input type="checkbox"/> <input type="checkbox"/> <input type="checkbox"/> <input type="checkbox"/></p> <p>1305 cylinder <input type="checkbox"/> <input type="checkbox"/> <input type="checkbox"/> <input type="checkbox"/> <input type="checkbox"/></p> <p>1306 boom speed <input type="checkbox"/> <input type="checkbox"/> <input type="checkbox"/> <input type="checkbox"/> <input type="checkbox"/></p> <p>1307 pressure settings <input type="checkbox"/> <input type="checkbox"/> <input type="checkbox"/> <input type="checkbox"/> <input type="checkbox"/></p> <p>1308 hydraulic lines <input type="checkbox"/> <input type="checkbox"/> <input type="checkbox"/> <input type="checkbox"/> <input type="checkbox"/></p> <p>1309 load holding valve (piston side) <input type="checkbox"/> <input type="checkbox"/> <input type="checkbox"/> <input type="checkbox"/> <input type="checkbox"/></p> <p>1310 load holding valve (rod side) <input type="checkbox"/> <input type="checkbox"/> <input type="checkbox"/> <input type="checkbox"/> <input type="checkbox"/></p> <p>1400 concrete delivery line</p> <p>1401 assembly of delivery line DN <input type="checkbox"/> <input type="checkbox"/> <input type="checkbox"/> <input type="checkbox"/> <input type="checkbox"/></p> <p>1402 end hose DN+height <input type="checkbox"/> <input type="checkbox"/> <input type="checkbox"/> <input type="checkbox"/> <input type="checkbox"/></p> <p>1403 delivery line DN <input type="checkbox"/> <input type="checkbox"/> <input type="checkbox"/> <input type="checkbox"/> <input type="checkbox"/></p> <p>1404 rotating joints of - delivery line <input type="checkbox"/> <input type="checkbox"/> <input type="checkbox"/> <input type="checkbox"/> <input type="checkbox"/></p> <p>1405 locking pin of the coupling <input type="checkbox"/> <input type="checkbox"/> <input type="checkbox"/> <input type="checkbox"/> <input type="checkbox"/></p> <p>Notes:</p> <hr/> <hr/> <hr/>
---	--

Inspection report for concrete booms

Page 5-5

Inspection report Nr: _____ Boom type: _____ Machine-Nr: _____

Error code:

00 no objections	08 corrosion	16 porous	24 deformation
01 cracks	09 lacquer failures	17 burned through	25 bear movement
02 broken	10 fraying	18 not fixed	26 lubrication
03 leaky	11 scratched	19 clomp	27 readability
04 no function	12 bendet	20 sawing	28 missing components
05 low lifetime	13 noises	21 contaminated	29 hydraulical
06 worn out	14 vibration	22 bad contact	30 electrical
07 dirt	15 miscellaneous	23 temperature	31 reinspection required

1406 end hose safety device

1407 reducer

1408 gate elbow, elbow 6"

1500 hydraulic system and hydraulic valves

1501 Pressure relief valve

1502 pressure settings

1503 hydraulic lines

1504 hand operating-
(function)

1505 boom control valve

1506 hydraulic pump

1600 electric equipment

1601 remote control
(functions)

1602 emergency stop
(function)

1603 switch for outrigger
function

1604 switch for boom
function

1605 wiring harness

1606 central lubrication

1700 sticker sets

1701 safety hints

1702 description

1703 operating

1704 short operating
instruction

1705 sticker „don't use
the boom as crane“

1706 sticker „guideline
operating with boom-
and concrete pump“

1707 name plate

1708 sticker „danger
high voltage“

Competent inspector:

Date: _____

Name: _____

Signature: _____
(stamp)

Customer:

Signature: _____
(stamp)

Inspection report for concrete pump

Inspection report Nr:	Machine-Nr:	Hours of operation:
		Concrete output m ³ :
Company:	Post code:	City:

NL	WV
----	----

Proof – Result of the tests

without defects	defects	reinspection required	shut down
<input type="checkbox"/>	<input type="checkbox"/>	<input type="checkbox"/>	<input type="checkbox"/>

Reinspection until date:

Error code:

- | | | | |
|------------------|---------------------|-------------------|--------------------------|
| 00 no objections | 08 corrosion | 16 porous | 24 deformation |
| 01 cracks | 09 lacquer failures | 17 burned through | 25 bear movement |
| 02 broken | 10 fraying | 18 not fixed | 26 lubrication |
| 03 leaky | 11 scratched | 19 clomp | 27 readability |
| 04 no fuction | 12 bendet | 20 sawing | 28 missing components |
| 05 low livetime | 13 noises | 21 contaminated | 29 hydraulical |
| 06 wom out | 14 vibration | 22 bad contact | 30 electrical |
| 07 dirt | 15 miscellaneous | 23 temperature | 31 reinspection required |

2000 documents

2001 operating manual	<input type="checkbox"/>	<input type="checkbox"/>	<input type="checkbox"/>	<input type="checkbox"/>
2002 spare parts list	<input type="checkbox"/>	<input type="checkbox"/>	<input type="checkbox"/>	<input type="checkbox"/>

2100 drive assembly

2101 coupling and flange	<input type="checkbox"/>	<input type="checkbox"/>	<input type="checkbox"/>	<input type="checkbox"/>
--------------------------	--------------------------	--------------------------	--------------------------	--------------------------

2200 gear box	<input type="checkbox"/>	<input type="checkbox"/>	<input type="checkbox"/>	<input type="checkbox"/>
---------------	--------------------------	--------------------------	--------------------------	--------------------------

2300 hydraulic pump (main)	<input type="checkbox"/>	<input type="checkbox"/>	<input type="checkbox"/>	<input type="checkbox"/>
----------------------------	--------------------------	--------------------------	--------------------------	--------------------------

2400 oil-tank	<input type="checkbox"/>	<input type="checkbox"/>	<input type="checkbox"/>	<input type="checkbox"/>
---------------	--------------------------	--------------------------	--------------------------	--------------------------

2500 drive shaft	<input type="checkbox"/>	<input type="checkbox"/>	<input type="checkbox"/>	<input type="checkbox"/>
------------------	--------------------------	--------------------------	--------------------------	--------------------------

2700 hydraulic control system

2701 pressure relief valve	<input type="checkbox"/>	<input type="checkbox"/>	<input type="checkbox"/>	<input type="checkbox"/>
----------------------------	--------------------------	--------------------------	--------------------------	--------------------------

2702 pressure setting	<input type="checkbox"/>	<input type="checkbox"/>	<input type="checkbox"/>	<input type="checkbox"/>
-----------------------	--------------------------	--------------------------	--------------------------	--------------------------

2703 hydraulic line	<input type="checkbox"/>	<input type="checkbox"/>	<input type="checkbox"/>	<input type="checkbox"/>
---------------------	--------------------------	--------------------------	--------------------------	--------------------------

2704 mechanical operation by hand	<input type="checkbox"/>	<input type="checkbox"/>	<input type="checkbox"/>	<input type="checkbox"/>
-----------------------------------	--------------------------	--------------------------	--------------------------	--------------------------

2800 oil -cooler	<input type="checkbox"/>	<input type="checkbox"/>	<input type="checkbox"/>	<input type="checkbox"/>
------------------	--------------------------	--------------------------	--------------------------	--------------------------

2900 accumulator	<input type="checkbox"/>	<input type="checkbox"/>	<input type="checkbox"/>	<input type="checkbox"/>
------------------	--------------------------	--------------------------	--------------------------	--------------------------

2901 proofs of the required tests according to accumulator regulation	<input type="checkbox"/>	<input type="checkbox"/>	<input type="checkbox"/>	<input type="checkbox"/>
---	--------------------------	--------------------------	--------------------------	--------------------------

2902 pressure gauge	<input type="checkbox"/>	<input type="checkbox"/>	<input type="checkbox"/>	<input type="checkbox"/>
---------------------	--------------------------	--------------------------	--------------------------	--------------------------

Notes:

Inspection report for concrete pump

Inspection report Nr: _____ Machine-Nr: _____

Error code:

- | | | | |
|------------------|---------------------|-------------------|--------------------------|
| 00 no objections | 08 corrosion | 16 porous | 24 deformation |
| 01 cracks | 09 lacquer failures | 17 burned through | 25 bear movement |
| 02 broken | 10 fraying | 18 not fixed | 26 lubrication |
| 03 leaky | 11 scratched | 19 clomp | 27 readability |
| 04 no function | 12 bendet | 20 sawing | 28 missing components |
| 05 low lifetime | 13 noises | 21 contaminated | 29 hydraulical |
| 06 worn out | 14 vibration | 22 bad contact | 30 electrical |
| 07 dirt | 15 miscellaneous | 23 temperature | 31 reinspection required |

<p>3000 central lubrication <input type="checkbox"/> <input type="checkbox"/> <input type="checkbox"/> <input type="checkbox"/> <input type="checkbox"/></p> <p>3100 hydraulic motor <input type="checkbox"/> <input type="checkbox"/> <input type="checkbox"/> <input type="checkbox"/> <input type="checkbox"/></p> <p>3200 hydraulic lines <input type="checkbox"/> <input type="checkbox"/> <input type="checkbox"/> <input type="checkbox"/> <input type="checkbox"/></p> <p>3300 air compressor <input type="checkbox"/> <input type="checkbox"/> <input type="checkbox"/> <input type="checkbox"/> <input type="checkbox"/></p> <p>3400 control panel <input type="checkbox"/> <input type="checkbox"/> <input type="checkbox"/> <input type="checkbox"/> <input type="checkbox"/></p> <p>3500 concrete pump <input type="checkbox"/> <input type="checkbox"/> <input type="checkbox"/> <input type="checkbox"/> <input type="checkbox"/></p> <p>3700 S-valve <input type="checkbox"/> <input type="checkbox"/> <input type="checkbox"/> <input type="checkbox"/> <input type="checkbox"/></p> <p>3800 hopper <input type="checkbox"/> <input type="checkbox"/> <input type="checkbox"/> <input type="checkbox"/> <input type="checkbox"/></p> <p>4100 sub frame <input type="checkbox"/> <input type="checkbox"/> <input type="checkbox"/> <input type="checkbox"/> <input type="checkbox"/></p> <p>4200 water tank <input type="checkbox"/> <input type="checkbox"/> <input type="checkbox"/> <input type="checkbox"/> <input type="checkbox"/></p> <p>4300 axle <input type="checkbox"/> <input type="checkbox"/> <input type="checkbox"/> <input type="checkbox"/> <input type="checkbox"/></p> <p>4400 water pump <input type="checkbox"/> <input type="checkbox"/> <input type="checkbox"/> <input type="checkbox"/> <input type="checkbox"/></p> <p>4500 vibrator <input type="checkbox"/> <input type="checkbox"/> <input type="checkbox"/> <input type="checkbox"/> <input type="checkbox"/></p>	<p>4600 safety guards, equipment</p> <p>4601 stair <input type="checkbox"/> <input type="checkbox"/> <input type="checkbox"/> <input type="checkbox"/> <input type="checkbox"/></p> <p>4602 safety for stair <input type="checkbox"/> <input type="checkbox"/> <input type="checkbox"/> <input type="checkbox"/> <input type="checkbox"/></p> <p>4603 handrail <input type="checkbox"/> <input type="checkbox"/> <input type="checkbox"/> <input type="checkbox"/> <input type="checkbox"/></p> <p>4604 hopper grid (fixing device) <input type="checkbox"/> <input type="checkbox"/> <input type="checkbox"/> <input type="checkbox"/> <input type="checkbox"/></p> <p>4606 distance of grid rods <input type="checkbox"/> <input type="checkbox"/> <input type="checkbox"/> <input type="checkbox"/> <input type="checkbox"/></p> <p>4607 distance from grid to agitator <input type="checkbox"/> <input type="checkbox"/> <input type="checkbox"/> <input type="checkbox"/> <input type="checkbox"/></p> <p>4609 agitator have to stop if grid is open <input type="checkbox"/> <input type="checkbox"/> <input type="checkbox"/> <input type="checkbox"/> <input type="checkbox"/></p> <p>4610 accumulator have to dump if grid is open <input type="checkbox"/> <input type="checkbox"/> <input type="checkbox"/> <input type="checkbox"/> <input type="checkbox"/></p> <p>4612 cleaning flap hopper <input type="checkbox"/> <input type="checkbox"/> <input type="checkbox"/> <input type="checkbox"/> <input type="checkbox"/></p> <p>4613 safety grid into water box <input type="checkbox"/> <input type="checkbox"/> <input type="checkbox"/> <input type="checkbox"/> <input type="checkbox"/></p>
--	---

Notes:

Inspection report for concrete pump

Inspection report Nr: _____ Machine-Nr: _____

Error code:

- | | | | |
|------------------|---------------------|-------------------|--------------------------|
| 00 no objections | 08 corrosion | 16 porous | 24 deformation |
| 01 cracks | 09 lacquer failures | 17 burned through | 25 bear movement |
| 02 broken | 10 fraying | 18 not fixed | 26 lubrication |
| 03 leaky | 11 scratched | 19 clomp | 27 readability |
| 04 no function | 12 bendet | 20 sawing | 28 missing components |
| 05 low lifetime | 13 noises | 21 contaminated | 29 hydraulical |
| 06 worn out | 14 vibration | 22 bad contact | 30 electrical |
| 07 dirt | 15 miscellaneous | 23 temperature | 31 reinspection required |

- 4614 cover for rotating wave
- 4616 cover for chains
- 4617 cover for shift cylinder
- 4618 cover for moving parts
- 4619 cover for the exhaust pipe

- 4700 electrical system**
- 4701 function of actuator component
- 4702 emergency stop function
- 4703 ground connections
- 4704 cables and wiring harness
- 4705 temperature switch

- 4800 outrigger - system**
- 4801 transportation lock
- 4802 locking device
- 4803 backing plate

- 4804 jack cylinder connections
- 4805 pressure adjustment of jack cylinder
- 4900 miscellaneous**
- 4901 additional assembled part from operator
- 4902 changes through operator

Competent inspector:

Date: _____

Name: _____

Signature: _____
(stamp)

Customer:

Signature: _____
(stamp)

This test report is filed into the test book

Inspection report for concrete booms

Inspection report -Nr:	Machine-Nr	Hours of operation:
		Concrete output m ³ :
Company:	Post code:	City:
Boom Type:	Boom Nr.	NL WV

Proof - Result of the Tests

without defects	defects	reinspection required	shut down
<input type="checkbox"/>	<input type="checkbox"/>	<input type="checkbox"/>	<input type="checkbox"/>

Reinspection until date:

Error code:

- | | | | |
|------------------|---------------------|-------------------|--------------------------|
| 00 no objections | 08 corrosion | 16 porous | 24 deformation |
| 01 cracks | 09 lacquer failures | 17 burned through | 25 bear movement |
| 02 broken | 10 fraying | 18 not fixed | 26 lubrication |
| 03 leaky | 11 scratched | 19 clomp | 27 readability |
| 04 no function | 12 bendet | 20 sawing | 28 missing components |
| 05 low lifetime | 13 noises | 21 contaminated | 29 hydraulical |
| 06 worn out | 14 vibration | 22 bad contact | 30 electrical |
| 07 dirt | 15 miscellaneous | 23 temperature | 31 reinspection required |

<p>100 documents</p> <p>101 instruction manual <input type="checkbox"/> <input type="checkbox"/> <input type="checkbox"/> <input type="checkbox"/> <input type="checkbox"/> <input type="checkbox"/></p> <p>102 spare parts list <input type="checkbox"/> <input type="checkbox"/> <input type="checkbox"/> <input type="checkbox"/> <input type="checkbox"/> <input type="checkbox"/></p> <p>200 sub frame</p> <p>201 frame connection cpl. <input type="checkbox"/> <input type="checkbox"/> <input type="checkbox"/> <input type="checkbox"/> <input type="checkbox"/> <input type="checkbox"/></p> <p>300 outrigger front R+L</p> <p>301 transportation safety device <input type="checkbox"/> <input type="checkbox"/> <input type="checkbox"/> <input type="checkbox"/> <input type="checkbox"/> <input type="checkbox"/></p> <p>302 outrigger <input type="checkbox"/> <input type="checkbox"/> <input type="checkbox"/> <input type="checkbox"/> <input type="checkbox"/> <input type="checkbox"/></p> <p>303 extension box <input type="checkbox"/> <input type="checkbox"/> <input type="checkbox"/> <input type="checkbox"/> <input type="checkbox"/> <input type="checkbox"/></p> <p>304 locking device <input type="checkbox"/> <input type="checkbox"/> <input type="checkbox"/> <input type="checkbox"/> <input type="checkbox"/> <input type="checkbox"/></p> <p>305 slewing bearing <input type="checkbox"/> <input type="checkbox"/> <input type="checkbox"/> <input type="checkbox"/> <input type="checkbox"/> <input type="checkbox"/></p> <p>306 turn locking device <input type="checkbox"/> <input type="checkbox"/> <input type="checkbox"/> <input type="checkbox"/> <input type="checkbox"/> <input type="checkbox"/></p> <p>307 support safeguard <input type="checkbox"/> <input type="checkbox"/> <input type="checkbox"/> <input type="checkbox"/> <input type="checkbox"/> <input type="checkbox"/></p> <p>308 support plate <input type="checkbox"/> <input type="checkbox"/> <input type="checkbox"/> <input type="checkbox"/> <input type="checkbox"/> <input type="checkbox"/></p> <p>309 fixing of jack cylinder <input type="checkbox"/> <input type="checkbox"/> <input type="checkbox"/> <input type="checkbox"/> <input type="checkbox"/> <input type="checkbox"/></p> <p>310 jack cylinder <input type="checkbox"/> <input type="checkbox"/> <input type="checkbox"/> <input type="checkbox"/> <input type="checkbox"/> <input type="checkbox"/></p>	<p>311 swing cylinder <input type="checkbox"/> <input type="checkbox"/> <input type="checkbox"/> <input type="checkbox"/> <input type="checkbox"/> <input type="checkbox"/></p> <p>312 telescopic-cylinder <input type="checkbox"/> <input type="checkbox"/> <input type="checkbox"/> <input type="checkbox"/> <input type="checkbox"/> <input type="checkbox"/></p> <p>313 pressure adjustment <input type="checkbox"/> <input type="checkbox"/> <input type="checkbox"/> <input type="checkbox"/> <input type="checkbox"/> <input type="checkbox"/></p> <p>400 outrigger rear L+R</p> <p>401 transportation safety device <input type="checkbox"/> <input type="checkbox"/> <input type="checkbox"/> <input type="checkbox"/> <input type="checkbox"/> <input type="checkbox"/></p> <p>402 outrigger <input type="checkbox"/> <input type="checkbox"/> <input type="checkbox"/> <input type="checkbox"/> <input type="checkbox"/> <input type="checkbox"/></p> <p>403 extension box <input type="checkbox"/> <input type="checkbox"/> <input type="checkbox"/> <input type="checkbox"/> <input type="checkbox"/> <input type="checkbox"/></p> <p>405 locking device <input type="checkbox"/> <input type="checkbox"/> <input type="checkbox"/> <input type="checkbox"/> <input type="checkbox"/> <input type="checkbox"/></p> <p>Notes:</p> <hr/> <hr/> <hr/> <hr/> <hr/> <hr/>
---	---

Inspection report for concrete booms

Inspection report Nr: _____ Boom type: _____ Machine-Nr: _____

Error code:

- | | | | |
|------------------|---------------------|-------------------|--------------------------|
| 00 no objections | 08 corrosion | 16 porous | 24 deformation |
| 01 cracks | 09 lacquer failures | 17 burned through | 25 bear movement |
| 02 broken | 10 fraying | 18 not fixed | 26 lubrication |
| 03 leaky | 11 scratched | 19 clomp | 27 readability |
| 04 no function | 12 bendet | 20 sawing | 28 missing components |
| 05 low lifetime | 13 noises | 21 contaminated | 29 hydraulical |
| 06 worn out | 14 vibration | 22 bad contact | 30 electrical |
| 07 dirt | 15 miscellaneous | 23 temperature | 31 reinspection required |

<p>406 slewing bearing <input type="checkbox"/> <input type="checkbox"/> <input type="checkbox"/> <input type="checkbox"/> <input type="checkbox"/></p> <p>407 turn locking device <input type="checkbox"/> <input type="checkbox"/> <input type="checkbox"/> <input type="checkbox"/> <input type="checkbox"/></p> <p>408 support safeguard <input type="checkbox"/> <input type="checkbox"/> <input type="checkbox"/> <input type="checkbox"/> <input type="checkbox"/></p> <p>409 support plate <input type="checkbox"/> <input type="checkbox"/> <input type="checkbox"/> <input type="checkbox"/> <input type="checkbox"/></p> <p>410 fixing of jack cylinder <input type="checkbox"/> <input type="checkbox"/> <input type="checkbox"/> <input type="checkbox"/> <input type="checkbox"/></p> <p>411 jack cylinder <input type="checkbox"/> <input type="checkbox"/> <input type="checkbox"/> <input type="checkbox"/> <input type="checkbox"/></p> <p>412 swing cylinder <input type="checkbox"/> <input type="checkbox"/> <input type="checkbox"/> <input type="checkbox"/> <input type="checkbox"/></p> <p>413 telescopic cylinder <input type="checkbox"/> <input type="checkbox"/> <input type="checkbox"/> <input type="checkbox"/> <input type="checkbox"/></p> <p>500 pedestal</p> <p>501 pedestal mounting <input type="checkbox"/> <input type="checkbox"/> <input type="checkbox"/> <input type="checkbox"/> <input type="checkbox"/></p> <p>502 sub frame <input type="checkbox"/> <input type="checkbox"/> <input type="checkbox"/> <input type="checkbox"/> <input type="checkbox"/></p> <p>503 truck frame <input type="checkbox"/> <input type="checkbox"/> <input type="checkbox"/> <input type="checkbox"/> <input type="checkbox"/></p> <p>504 pedestal (structure) <input type="checkbox"/> <input type="checkbox"/> <input type="checkbox"/> <input type="checkbox"/> <input type="checkbox"/></p> <p>505 boom valve without leaking <input type="checkbox"/> <input type="checkbox"/> <input type="checkbox"/> <input type="checkbox"/> <input type="checkbox"/></p> <p>506 boom rest <input type="checkbox"/> <input type="checkbox"/> <input type="checkbox"/> <input type="checkbox"/> <input type="checkbox"/></p> <p>507 transportation safety device <input type="checkbox"/> <input type="checkbox"/> <input type="checkbox"/> <input type="checkbox"/> <input type="checkbox"/></p> <p>508 hydraulic line <input type="checkbox"/> <input type="checkbox"/> <input type="checkbox"/> <input type="checkbox"/> <input type="checkbox"/></p> <p>600 slewing head with ball pivot</p> <p>601 slewing head <input type="checkbox"/> <input type="checkbox"/> <input type="checkbox"/> <input type="checkbox"/> <input type="checkbox"/></p> <p>602 ball pivot ring <input type="checkbox"/> <input type="checkbox"/> <input type="checkbox"/> <input type="checkbox"/> <input type="checkbox"/></p> <p>603 mounting ball pivot ring <input type="checkbox"/> <input type="checkbox"/> <input type="checkbox"/> <input type="checkbox"/> <input type="checkbox"/></p> <p>604 drive pinion <input type="checkbox"/> <input type="checkbox"/> <input type="checkbox"/> <input type="checkbox"/> <input type="checkbox"/></p>	<p>605 slewing drive mounting <input type="checkbox"/> <input type="checkbox"/> <input type="checkbox"/> <input type="checkbox"/> <input type="checkbox"/></p> <p>606 slewing stop device <input type="checkbox"/> <input type="checkbox"/> <input type="checkbox"/> <input type="checkbox"/> <input type="checkbox"/></p> <p>607 slewing drive (tooth backlash) <input type="checkbox"/> <input type="checkbox"/> <input type="checkbox"/> <input type="checkbox"/> <input type="checkbox"/></p> <p>608 slewing drive <input type="checkbox"/> <input type="checkbox"/> <input type="checkbox"/> <input type="checkbox"/> <input type="checkbox"/></p> <p>609 brake function <input type="checkbox"/> <input type="checkbox"/> <input type="checkbox"/> <input type="checkbox"/> <input type="checkbox"/></p> <p>610 speed <input type="checkbox"/> <input type="checkbox"/> <input type="checkbox"/> <input type="checkbox"/> <input type="checkbox"/></p> <p>611 pressure setting <input type="checkbox"/> <input type="checkbox"/> <input type="checkbox"/> <input type="checkbox"/> <input type="checkbox"/></p> <p>612 hydraulic lines <input type="checkbox"/> <input type="checkbox"/> <input type="checkbox"/> <input type="checkbox"/> <input type="checkbox"/></p> <p>700 slewing head with slewing column</p> <p>701 slewing head <input type="checkbox"/> <input type="checkbox"/> <input type="checkbox"/> <input type="checkbox"/> <input type="checkbox"/></p> <p>702 slewing column bearing <input type="checkbox"/> <input type="checkbox"/> <input type="checkbox"/> <input type="checkbox"/> <input type="checkbox"/></p> <p>703 slewing drive (tooth backlash) <input type="checkbox"/> <input type="checkbox"/> <input type="checkbox"/> <input type="checkbox"/> <input type="checkbox"/></p> <p>704 speed <input type="checkbox"/> <input type="checkbox"/> <input type="checkbox"/> <input type="checkbox"/> <input type="checkbox"/></p> <p>705 pressure settings <input type="checkbox"/> <input type="checkbox"/> <input type="checkbox"/> <input type="checkbox"/> <input type="checkbox"/></p> <p>706 hydraulic lines <input type="checkbox"/> <input type="checkbox"/> <input type="checkbox"/> <input type="checkbox"/> <input type="checkbox"/></p> <p>707 swivel cylinder <input type="checkbox"/> <input type="checkbox"/> <input type="checkbox"/> <input type="checkbox"/> <input type="checkbox"/></p> <p>Notes:</p> <hr/> <hr/> <hr/> <hr/>
---	---

Inspection report for concrete booms

Inspection report Nr:	Boom type:	Machine-Nr:																																
<p>Error code:</p> <table style="width: 100%; border: none;"> <tr> <td style="width: 25%;">00 no objections</td> <td style="width: 25%;">08 corrosion</td> <td style="width: 25%;">16 porous</td> <td style="width: 25%;">24 deformation</td> </tr> <tr> <td>01 cracks</td> <td>09 lacquer failures</td> <td>17 burned through</td> <td>25 bear movement</td> </tr> <tr> <td>02 broken</td> <td>10 fraying</td> <td>18 not fixed</td> <td>26 lubrication</td> </tr> <tr> <td>03 leaky</td> <td>11 scratched</td> <td>19 clemp</td> <td>27 readability</td> </tr> <tr> <td>04 no function</td> <td>12 bendet</td> <td>20 sawing</td> <td>28 missing components</td> </tr> <tr> <td>05 low lifetime</td> <td>13 noises</td> <td>21 contaminated</td> <td>29 hydraulical</td> </tr> <tr> <td>06 worn out</td> <td>14 vibration</td> <td>22 bad contact</td> <td>30 electrical</td> </tr> <tr> <td>07 dirt</td> <td>15 miscellaneous</td> <td>23 temperature</td> <td>31 reinspection required</td> </tr> </table>			00 no objections	08 corrosion	16 porous	24 deformation	01 cracks	09 lacquer failures	17 burned through	25 bear movement	02 broken	10 fraying	18 not fixed	26 lubrication	03 leaky	11 scratched	19 clemp	27 readability	04 no function	12 bendet	20 sawing	28 missing components	05 low lifetime	13 noises	21 contaminated	29 hydraulical	06 worn out	14 vibration	22 bad contact	30 electrical	07 dirt	15 miscellaneous	23 temperature	31 reinspection required
00 no objections	08 corrosion	16 porous	24 deformation																															
01 cracks	09 lacquer failures	17 burned through	25 bear movement																															
02 broken	10 fraying	18 not fixed	26 lubrication																															
03 leaky	11 scratched	19 clemp	27 readability																															
04 no function	12 bendet	20 sawing	28 missing components																															
05 low lifetime	13 noises	21 contaminated	29 hydraulical																															
06 worn out	14 vibration	22 bad contact	30 electrical																															
07 dirt	15 miscellaneous	23 temperature	31 reinspection required																															

<p>800 boom</p> <p>801 „Arm 1“ <input type="checkbox"/> <input type="checkbox"/> <input type="checkbox"/> <input type="checkbox"/> <input type="checkbox"/></p> <p>802 bracket conveying line <input type="checkbox"/> <input type="checkbox"/> <input type="checkbox"/> <input type="checkbox"/> <input type="checkbox"/></p> <p>803 Drop hook <input type="checkbox"/> <input type="checkbox"/> <input type="checkbox"/> <input type="checkbox"/> <input type="checkbox"/></p> <p>804 „Arm 2“ <input type="checkbox"/> <input type="checkbox"/> <input type="checkbox"/> <input type="checkbox"/> <input type="checkbox"/></p> <p>805 bracket conveying line <input type="checkbox"/> <input type="checkbox"/> <input type="checkbox"/> <input type="checkbox"/> <input type="checkbox"/></p> <p>806 Drop hook <input type="checkbox"/> <input type="checkbox"/> <input type="checkbox"/> <input type="checkbox"/> <input type="checkbox"/></p> <p>807 „Arm 3“ <input type="checkbox"/> <input type="checkbox"/> <input type="checkbox"/> <input type="checkbox"/> <input type="checkbox"/></p> <p>808 bracket conveying line <input type="checkbox"/> <input type="checkbox"/> <input type="checkbox"/> <input type="checkbox"/> <input type="checkbox"/></p> <p>809 guidance and interlock of the arm <input type="checkbox"/> <input type="checkbox"/> <input type="checkbox"/> <input type="checkbox"/> <input type="checkbox"/></p> <p>810 „Arm 4“ <input type="checkbox"/> <input type="checkbox"/> <input type="checkbox"/> <input type="checkbox"/> <input type="checkbox"/></p> <p>811 bracket conveying line <input type="checkbox"/> <input type="checkbox"/> <input type="checkbox"/> <input type="checkbox"/> <input type="checkbox"/></p> <p>812 guidance and interlock of the arm <input type="checkbox"/> <input type="checkbox"/> <input type="checkbox"/> <input type="checkbox"/> <input type="checkbox"/></p> <p>813 „Arm 5“ <input type="checkbox"/> <input type="checkbox"/> <input type="checkbox"/> <input type="checkbox"/> <input type="checkbox"/></p> <p>814 bracket conveying line <input type="checkbox"/> <input type="checkbox"/> <input type="checkbox"/> <input type="checkbox"/> <input type="checkbox"/></p> <p>815 guidance and interlock of the arm <input type="checkbox"/> <input type="checkbox"/> <input type="checkbox"/> <input type="checkbox"/> <input type="checkbox"/></p> <p>900 joint „A“</p> <p>901 boom <input type="checkbox"/> <input type="checkbox"/> <input type="checkbox"/> <input type="checkbox"/> <input type="checkbox"/></p> <p>902 link lever <input type="checkbox"/> <input type="checkbox"/> <input type="checkbox"/> <input type="checkbox"/> <input type="checkbox"/></p> <p>903 forcing rod <input type="checkbox"/> <input type="checkbox"/> <input type="checkbox"/> <input type="checkbox"/> <input type="checkbox"/></p> <p>904 pin <input type="checkbox"/> <input type="checkbox"/> <input type="checkbox"/> <input type="checkbox"/> <input type="checkbox"/></p> <p>905 cylinder <input type="checkbox"/> <input type="checkbox"/> <input type="checkbox"/> <input type="checkbox"/> <input type="checkbox"/></p>	<p>906 boom speed <input type="checkbox"/> <input type="checkbox"/> <input type="checkbox"/> <input type="checkbox"/> <input type="checkbox"/></p> <p>907 pressure settings <input type="checkbox"/> <input type="checkbox"/> <input type="checkbox"/> <input type="checkbox"/> <input type="checkbox"/></p> <p>908 hydraulic lines <input type="checkbox"/> <input type="checkbox"/> <input type="checkbox"/> <input type="checkbox"/> <input type="checkbox"/></p> <p>909 load holding valve (piston side) <input type="checkbox"/> <input type="checkbox"/> <input type="checkbox"/> <input type="checkbox"/> <input type="checkbox"/></p> <p>910 load holding valve (rod side) <input type="checkbox"/> <input type="checkbox"/> <input type="checkbox"/> <input type="checkbox"/> <input type="checkbox"/></p> <p>1000 joint „B“</p> <p>1001 boom <input type="checkbox"/> <input type="checkbox"/> <input type="checkbox"/> <input type="checkbox"/> <input type="checkbox"/></p> <p>1002 link lever <input type="checkbox"/> <input type="checkbox"/> <input type="checkbox"/> <input type="checkbox"/> <input type="checkbox"/></p> <p>1003 forcing rod <input type="checkbox"/> <input type="checkbox"/> <input type="checkbox"/> <input type="checkbox"/> <input type="checkbox"/></p> <p>1004 pin <input type="checkbox"/> <input type="checkbox"/> <input type="checkbox"/> <input type="checkbox"/> <input type="checkbox"/></p> <p>1005 cylinder <input type="checkbox"/> <input type="checkbox"/> <input type="checkbox"/> <input type="checkbox"/> <input type="checkbox"/></p> <p>1006 boom speed <input type="checkbox"/> <input type="checkbox"/> <input type="checkbox"/> <input type="checkbox"/> <input type="checkbox"/></p> <p>1007 pressure settings <input type="checkbox"/> <input type="checkbox"/> <input type="checkbox"/> <input type="checkbox"/> <input type="checkbox"/></p> <p>1008 hydraulic lines <input type="checkbox"/> <input type="checkbox"/> <input type="checkbox"/> <input type="checkbox"/> <input type="checkbox"/></p> <p>1009 load holding valve (piston side) <input type="checkbox"/> <input type="checkbox"/> <input type="checkbox"/> <input type="checkbox"/> <input type="checkbox"/></p> <p>1010 load holding valve (rod side) <input type="checkbox"/> <input type="checkbox"/> <input type="checkbox"/> <input type="checkbox"/> <input type="checkbox"/></p> <p>Notes:</p> <hr/> <hr/> <hr/> <hr/>
--	---

Inspection report for concrete booms

Inspection report Nr: _____ Boom type: _____ Machine-Nr: _____

Error code:			
00 no objections	08 corrosion	16 porous	24 deformation
01 cracks	09 lacquer failures	17 burned through	25 bear movement
02 broken	10 fraying	18 not fixed	26 lubrication
03 leaky	11 scratched	19 clomp	27 readability
04 no function	12 bendet	20 sawing	28 missing components
05 low lifetime	13 noises	21 contaminated	29 hydraulical
06 worn out	14 vibration	22 bad contact	30 electrical
07 dirt	15 miscellaneous	23 temperature	31 reinspection required

<p>1100 joint "C"</p> <p>1101 boom <input type="checkbox"/> <input type="checkbox"/> <input type="checkbox"/> <input type="checkbox"/> <input type="checkbox"/></p> <p>1102 link lever <input type="checkbox"/> <input type="checkbox"/> <input type="checkbox"/> <input type="checkbox"/> <input type="checkbox"/></p> <p>1103 forcing rod <input type="checkbox"/> <input type="checkbox"/> <input type="checkbox"/> <input type="checkbox"/> <input type="checkbox"/></p> <p>1104 pin <input type="checkbox"/> <input type="checkbox"/> <input type="checkbox"/> <input type="checkbox"/> <input type="checkbox"/></p> <p>1105 cylinder <input type="checkbox"/> <input type="checkbox"/> <input type="checkbox"/> <input type="checkbox"/> <input type="checkbox"/></p> <p>1106 boom speed <input type="checkbox"/> <input type="checkbox"/> <input type="checkbox"/> <input type="checkbox"/> <input type="checkbox"/></p> <p>1107 pressure settings <input type="checkbox"/> <input type="checkbox"/> <input type="checkbox"/> <input type="checkbox"/> <input type="checkbox"/></p> <p>1108 hydraulic lines <input type="checkbox"/> <input type="checkbox"/> <input type="checkbox"/> <input type="checkbox"/> <input type="checkbox"/></p> <p>1109 load holding valve (piston side) <input type="checkbox"/> <input type="checkbox"/> <input type="checkbox"/> <input type="checkbox"/> <input type="checkbox"/></p> <p>1110 load holding valve (rod side) <input type="checkbox"/> <input type="checkbox"/> <input type="checkbox"/> <input type="checkbox"/> <input type="checkbox"/></p> <p>1200 joint "D"</p> <p>1201 boom <input type="checkbox"/> <input type="checkbox"/> <input type="checkbox"/> <input type="checkbox"/> <input type="checkbox"/></p> <p>1202 link lever <input type="checkbox"/> <input type="checkbox"/> <input type="checkbox"/> <input type="checkbox"/> <input type="checkbox"/></p> <p>1203 forcing rod <input type="checkbox"/> <input type="checkbox"/> <input type="checkbox"/> <input type="checkbox"/> <input type="checkbox"/></p> <p>1204 pin <input type="checkbox"/> <input type="checkbox"/> <input type="checkbox"/> <input type="checkbox"/> <input type="checkbox"/></p> <p>1205 cylinder <input type="checkbox"/> <input type="checkbox"/> <input type="checkbox"/> <input type="checkbox"/> <input type="checkbox"/></p> <p>1206 boom speed <input type="checkbox"/> <input type="checkbox"/> <input type="checkbox"/> <input type="checkbox"/> <input type="checkbox"/></p> <p>1207 pressure settings <input type="checkbox"/> <input type="checkbox"/> <input type="checkbox"/> <input type="checkbox"/> <input type="checkbox"/></p> <p>1208 hydraulic lines <input type="checkbox"/> <input type="checkbox"/> <input type="checkbox"/> <input type="checkbox"/> <input type="checkbox"/></p> <p>1209 load holding valve (piston side) <input type="checkbox"/> <input type="checkbox"/> <input type="checkbox"/> <input type="checkbox"/> <input type="checkbox"/></p> <p>1210 load holding valve (rod side) <input type="checkbox"/> <input type="checkbox"/> <input type="checkbox"/> <input type="checkbox"/> <input type="checkbox"/></p>	<p>1300 joint „E“</p> <p>1301 boom <input type="checkbox"/> <input type="checkbox"/> <input type="checkbox"/> <input type="checkbox"/> <input type="checkbox"/></p> <p>1302 link lever <input type="checkbox"/> <input type="checkbox"/> <input type="checkbox"/> <input type="checkbox"/> <input type="checkbox"/></p> <p>1303 forcing rod <input type="checkbox"/> <input type="checkbox"/> <input type="checkbox"/> <input type="checkbox"/> <input type="checkbox"/></p> <p>1304 pin <input type="checkbox"/> <input type="checkbox"/> <input type="checkbox"/> <input type="checkbox"/> <input type="checkbox"/></p> <p>1305 cylinder <input type="checkbox"/> <input type="checkbox"/> <input type="checkbox"/> <input type="checkbox"/> <input type="checkbox"/></p> <p>1306 boom speed <input type="checkbox"/> <input type="checkbox"/> <input type="checkbox"/> <input type="checkbox"/> <input type="checkbox"/></p> <p>1307 pressure settings <input type="checkbox"/> <input type="checkbox"/> <input type="checkbox"/> <input type="checkbox"/> <input type="checkbox"/></p> <p>1308 hydraulic lines <input type="checkbox"/> <input type="checkbox"/> <input type="checkbox"/> <input type="checkbox"/> <input type="checkbox"/></p> <p>1309 load holding valve (piston side) <input type="checkbox"/> <input type="checkbox"/> <input type="checkbox"/> <input type="checkbox"/> <input type="checkbox"/></p> <p>1310 load holding valve (rod side) <input type="checkbox"/> <input type="checkbox"/> <input type="checkbox"/> <input type="checkbox"/> <input type="checkbox"/></p> <p>1400 concrete delivery line</p> <p>1401 assembly of delivery line DN <input type="checkbox"/> <input type="checkbox"/> <input type="checkbox"/> <input type="checkbox"/> <input type="checkbox"/></p> <p>1402 end hose DN+length <input type="checkbox"/> <input type="checkbox"/> <input type="checkbox"/> <input type="checkbox"/> <input type="checkbox"/></p> <p>1403 delivery line DN <input type="checkbox"/> <input type="checkbox"/> <input type="checkbox"/> <input type="checkbox"/> <input type="checkbox"/></p> <p>1404 rotating joints of - delivery line <input type="checkbox"/> <input type="checkbox"/> <input type="checkbox"/> <input type="checkbox"/> <input type="checkbox"/></p> <p>1405 locking pin of the coupling <input type="checkbox"/> <input type="checkbox"/> <input type="checkbox"/> <input type="checkbox"/> <input type="checkbox"/></p> <p>Notes:</p> <hr/> <hr/> <hr/>
---	--

Inspection report for concrete booms

Page 5-5

Inspection report Nr: _____ Boom type: _____ Machine-Nr: _____

Error code:

- | | | | |
|------------------|---------------------|-------------------|--------------------------|
| 00 no objections | 08 corrosion | 16 porous | 24 deformation |
| 01 cracks | 09 lacquer failures | 17 burned through | 25 bear movement |
| 02 broken | 10 fraying | 18 not fixed | 26 lubrication |
| 03 leaky | 11 scratched | 19 clomp | 27 readability |
| 04 no function | 12 bendet | 20 sawing | 28 missing components |
| 05 low lifetime | 13 noises | 21 contaminated | 29 hydraulical |
| 06 worn out | 14 vibration | 22 bad contact | 30 electrical |
| 07 dirt | 15 miscellaneous | 23 temperature | 31 reinspection required |

1406 end hose safety device

1407 reducer

1408 gate elbow, elbow 6"

1500 hydraulic system and hydraulic valves

1501 Pressure relief valve

1502 pressure settings

1503 hydraulic lines

1504 hand operating-
(function)

1505 boom control valve

1506 hydraulic pump

1600 electric equipment

1601 remote control
(functions)

1602 emergency stop
(function)

1603 switch for outrigger
function

1604 switch for boom
function

1605 wiring harness

1606 central lubrication

1700 sticker sets

1701 safety hints

1702 description

1703 operating

1704 short operating
instruction

1705 sticker „don't use
the boom as crane“

1706 sticker „guideline
operating with boom-
and concrete pump“

1707 name plate

1708 sticker „danger
high voltage“

Competent inspector:

Date: _____

Name: _____

Signature: _____
(stamp)

Customer:

Signature: _____
(stamp)

Inspection report for concrete pump

Inspection report Nr:	Machine-Nr:	Hours of operation:
		Concrete output m ³ :
Company:	Post code:	City:

NL	WV
----	----

Proof – Result of the tests

without defects	defects	reinspection required	shut down
<input type="checkbox"/>	<input type="checkbox"/>	<input type="checkbox"/>	<input type="checkbox"/>

Reinspection until date:

Error code:

- | | | | |
|------------------|---------------------|-------------------|--------------------------|
| 00 no objections | 08 corrosion | 16 porous | 24 deformation |
| 01 cracks | 09 lacquer failures | 17 burned through | 25 bear movement |
| 02 broken | 10 fraying | 18 not fixed | 26 lubrication |
| 03 leaky | 11 scratched | 19 clamp | 27 readability |
| 04 no fuction | 12 bendet | 20 sawing | 28 missing components |
| 05 low livetime | 13 noises | 21 contaminated | 29 hydraulical |
| 06 worn out | 14 vibration | 22 bad contact | 30 electrical |
| 07 dirt | 15 miscellaneous | 23 temperature | 31 reinspection required |

2000 documents

2001 operating manual	<input type="checkbox"/>	<input type="checkbox"/>	<input type="checkbox"/>	<input type="checkbox"/>	<input type="checkbox"/>
2002 spare parts list	<input type="checkbox"/>	<input type="checkbox"/>	<input type="checkbox"/>	<input type="checkbox"/>	<input type="checkbox"/>
2100 drive assembly					
2101 coupling and flange	<input type="checkbox"/>	<input type="checkbox"/>	<input type="checkbox"/>	<input type="checkbox"/>	<input type="checkbox"/>
2200 gear box	<input type="checkbox"/>	<input type="checkbox"/>	<input type="checkbox"/>	<input type="checkbox"/>	<input type="checkbox"/>
2300 hydraulic pump (main)	<input type="checkbox"/>	<input type="checkbox"/>	<input type="checkbox"/>	<input type="checkbox"/>	<input type="checkbox"/>
2400 oil-tank	<input type="checkbox"/>	<input type="checkbox"/>	<input type="checkbox"/>	<input type="checkbox"/>	<input type="checkbox"/>
2500 drive shaft	<input type="checkbox"/>	<input type="checkbox"/>	<input type="checkbox"/>	<input type="checkbox"/>	<input type="checkbox"/>

2700 hydraulic control system

2701 pressure relief valve	<input type="checkbox"/>	<input type="checkbox"/>	<input type="checkbox"/>	<input type="checkbox"/>	<input type="checkbox"/>
2702 pressure setting	<input type="checkbox"/>	<input type="checkbox"/>	<input type="checkbox"/>	<input type="checkbox"/>	<input type="checkbox"/>
2703 hydraulic line	<input type="checkbox"/>	<input type="checkbox"/>	<input type="checkbox"/>	<input type="checkbox"/>	<input type="checkbox"/>
2704 mechanical operation by hand	<input type="checkbox"/>	<input type="checkbox"/>	<input type="checkbox"/>	<input type="checkbox"/>	<input type="checkbox"/>
2800 oil-cooler	<input type="checkbox"/>	<input type="checkbox"/>	<input type="checkbox"/>	<input type="checkbox"/>	<input type="checkbox"/>
2900 accumulator	<input type="checkbox"/>	<input type="checkbox"/>	<input type="checkbox"/>	<input type="checkbox"/>	<input type="checkbox"/>
2901 proofs of the required tests according to accumulator regulation	<input type="checkbox"/>	<input type="checkbox"/>	<input type="checkbox"/>	<input type="checkbox"/>	<input type="checkbox"/>
2902 pressure gauge	<input type="checkbox"/>	<input type="checkbox"/>	<input type="checkbox"/>	<input type="checkbox"/>	<input type="checkbox"/>

Notes:

Inspection report for concrete pump

Inspection report Nr: _____ Machine-Nr: _____

Error code:

- | | | | |
|------------------|---------------------|-------------------|--------------------------|
| 00 no objections | 08 corrosion | 16 porous | 24 deformation |
| 01 cracks | 09 lacquer failures | 17 burned through | 25 bear movement |
| 02 broken | 10 fraying | 18 not fixed | 26 lubrication |
| 03 leaky | 11 scratched | 19 clomp | 27 readability |
| 04 no function | 12 bendet | 20 sawing | 28 missing components |
| 05 low lifetime | 13 noises | 21 contaminated | 29 hydraulical |
| 06 worn out | 14 vibration | 22 bad contact | 30 electrical |
| 07 dirt | 15 miscellaneous | 23 temperature | 31 reinspection required |

<p>3000 central lubrication <input type="checkbox"/> <input type="checkbox"/> <input type="checkbox"/> <input type="checkbox"/> <input type="checkbox"/></p> <p>3100 hydraulic motor <input type="checkbox"/> <input type="checkbox"/> <input type="checkbox"/> <input type="checkbox"/> <input type="checkbox"/></p> <p>3200 hydraulic lines <input type="checkbox"/> <input type="checkbox"/> <input type="checkbox"/> <input type="checkbox"/> <input type="checkbox"/></p> <p>3300 air compressor <input type="checkbox"/> <input type="checkbox"/> <input type="checkbox"/> <input type="checkbox"/> <input type="checkbox"/></p> <p>3400 control panel <input type="checkbox"/> <input type="checkbox"/> <input type="checkbox"/> <input type="checkbox"/> <input type="checkbox"/></p> <p>3500 concrete pump <input type="checkbox"/> <input type="checkbox"/> <input type="checkbox"/> <input type="checkbox"/> <input type="checkbox"/></p> <p>3700 S-valve <input type="checkbox"/> <input type="checkbox"/> <input type="checkbox"/> <input type="checkbox"/> <input type="checkbox"/></p> <p>3800 hopper <input type="checkbox"/> <input type="checkbox"/> <input type="checkbox"/> <input type="checkbox"/> <input type="checkbox"/></p> <p>4100 sub frame <input type="checkbox"/> <input type="checkbox"/> <input type="checkbox"/> <input type="checkbox"/> <input type="checkbox"/></p> <p>4200 water tank <input type="checkbox"/> <input type="checkbox"/> <input type="checkbox"/> <input type="checkbox"/> <input type="checkbox"/></p> <p>4300 axle <input type="checkbox"/> <input type="checkbox"/> <input type="checkbox"/> <input type="checkbox"/> <input type="checkbox"/></p> <p>4400 water pump <input type="checkbox"/> <input type="checkbox"/> <input type="checkbox"/> <input type="checkbox"/> <input type="checkbox"/></p> <p>4500 vibrator <input type="checkbox"/> <input type="checkbox"/> <input type="checkbox"/> <input type="checkbox"/> <input type="checkbox"/></p>	<p>4600 safety guards, equipment</p> <p>4601 stair <input type="checkbox"/> <input type="checkbox"/> <input type="checkbox"/> <input type="checkbox"/> <input type="checkbox"/></p> <p>4602 safety for stair <input type="checkbox"/> <input type="checkbox"/> <input type="checkbox"/> <input type="checkbox"/> <input type="checkbox"/></p> <p>4603 handrail <input type="checkbox"/> <input type="checkbox"/> <input type="checkbox"/> <input type="checkbox"/> <input type="checkbox"/></p> <p>4604 hopper grid (fixing device) <input type="checkbox"/> <input type="checkbox"/> <input type="checkbox"/> <input type="checkbox"/> <input type="checkbox"/></p> <p>4606 distance of grid rods <input type="checkbox"/> <input type="checkbox"/> <input type="checkbox"/> <input type="checkbox"/> <input type="checkbox"/></p> <p>4607 distance from grid to agitator <input type="checkbox"/> <input type="checkbox"/> <input type="checkbox"/> <input type="checkbox"/> <input type="checkbox"/></p> <p>4609 agitator have to stop if grid is open <input type="checkbox"/> <input type="checkbox"/> <input type="checkbox"/> <input type="checkbox"/> <input type="checkbox"/></p> <p>4610 accumulator have to dump if grid is open <input type="checkbox"/> <input type="checkbox"/> <input type="checkbox"/> <input type="checkbox"/> <input type="checkbox"/></p> <p>4612 cleaning flap hopper <input type="checkbox"/> <input type="checkbox"/> <input type="checkbox"/> <input type="checkbox"/> <input type="checkbox"/></p> <p>4613 safety grid into water box <input type="checkbox"/> <input type="checkbox"/> <input type="checkbox"/> <input type="checkbox"/> <input type="checkbox"/></p>
--	---

Notes:

Inspection report for concrete pump

Inspection report Nr: _____ Machine-Nr: _____

Error code:

- | | | | |
|------------------|---------------------|-------------------|--------------------------|
| 00 no objections | 08 corrosion | 16 porous | 24 deformation |
| 01 cracks | 09 lacquer failures | 17 burned through | 25 bear movement |
| 02 broken | 10 fraying | 18 not fixed | 26 lubrication |
| 03 leaky | 11 scratched | 19 clomp | 27 readability |
| 04 no function | 12 bendet | 20 sawing | 28 missing components |
| 05 low lifetime | 13 noises | 21 contaminated | 29 hydraulical |
| 06 worn out | 14 vibration | 22 bad contact | 30 electrical |
| 07 dirt | 15 miscellaneous | 23 temperature | 31 reinspection required |

<p>4614 cover for rotating wave <input type="checkbox"/> <input type="checkbox"/> <input type="checkbox"/> <input type="checkbox"/> <input type="checkbox"/></p> <p>4616 cover for chains <input type="checkbox"/> <input type="checkbox"/> <input type="checkbox"/> <input type="checkbox"/> <input type="checkbox"/></p> <p>4617 cover for shift cylinder <input type="checkbox"/> <input type="checkbox"/> <input type="checkbox"/> <input type="checkbox"/> <input type="checkbox"/></p> <p>4618 cover for moving parts <input type="checkbox"/> <input type="checkbox"/> <input type="checkbox"/> <input type="checkbox"/> <input type="checkbox"/></p> <p>4619 cover for the exhaust pipe <input type="checkbox"/> <input type="checkbox"/> <input type="checkbox"/> <input type="checkbox"/> <input type="checkbox"/></p> <p>4700 electrical system</p> <p>4701 function of actuator component <input type="checkbox"/> <input type="checkbox"/> <input type="checkbox"/> <input type="checkbox"/> <input type="checkbox"/></p> <p>4702 emergency stop function <input type="checkbox"/> <input type="checkbox"/> <input type="checkbox"/> <input type="checkbox"/> <input type="checkbox"/></p> <p>4703 ground connections <input type="checkbox"/> <input type="checkbox"/> <input type="checkbox"/> <input type="checkbox"/> <input type="checkbox"/></p> <p>4704 cables and wiring harness <input type="checkbox"/> <input type="checkbox"/> <input type="checkbox"/> <input type="checkbox"/> <input type="checkbox"/></p> <p>4705 temperature switch <input type="checkbox"/> <input type="checkbox"/> <input type="checkbox"/> <input type="checkbox"/> <input type="checkbox"/></p> <p>4800 outrigger - system</p> <p>4801 transportation lock <input type="checkbox"/> <input type="checkbox"/> <input type="checkbox"/> <input type="checkbox"/> <input type="checkbox"/></p> <p>4802 locking device <input type="checkbox"/> <input type="checkbox"/> <input type="checkbox"/> <input type="checkbox"/> <input type="checkbox"/></p> <p>4803 backing plate <input type="checkbox"/> <input type="checkbox"/> <input type="checkbox"/> <input type="checkbox"/> <input type="checkbox"/></p>	<p>4804 jack cylinder connections <input type="checkbox"/> <input type="checkbox"/> <input type="checkbox"/> <input type="checkbox"/> <input type="checkbox"/></p> <p>4805 pressure adjustment of jack cylinder <input type="checkbox"/> <input type="checkbox"/> <input type="checkbox"/> <input type="checkbox"/> <input type="checkbox"/></p> <p>4900 miscellaneous</p> <p>4901 additional assembled part from operator <input type="checkbox"/> <input type="checkbox"/> <input type="checkbox"/> <input type="checkbox"/> <input type="checkbox"/></p> <p>4902 changes through operator <input type="checkbox"/> <input type="checkbox"/> <input type="checkbox"/> <input type="checkbox"/> <input type="checkbox"/></p> <p>Competent inspector:</p> <p>Date: _____</p> <p>Name: _____</p> <p>Signature: _____ (stamp)</p> <p>Customer:</p> <p>Signature: _____ (stamp)</p> <p style="text-align: center;">This test report is filed into the test book</p>
---	---

Inspection report for concrete booms

Inspection report -Nr:	Machine-Nr	Hours of operation:
		Concrete output m ³ :
Company:	Post code:	City:
Boom Type:	Boom Nr.	NL WV

Proof - Result of the Tests

without defects	defects	reinspection required	shut down
<input type="checkbox"/>	<input type="checkbox"/>	<input type="checkbox"/>	<input type="checkbox"/>

Reinspection until date:

Error code:

- | | | | |
|------------------|---------------------|-------------------|--------------------------|
| 00 no objections | 08 corrosion | 16 porous | 24 deformation |
| 01 cracks | 09 lacquer failures | 17 burned through | 25 bear movement |
| 02 broken | 10 fraying | 18 not fixed | 26 lubrication |
| 03 leaky | 11 scratched | 19 clomp | 27 readability |
| 04 no function | 12 bendet | 20 sawing | 28 missing components |
| 05 low lifetime | 13 noises | 21 contaminated | 29 hydraulic |
| 06 worn out | 14 vibration | 22 bad contact | 30 electrical |
| 07 dirt | 15 miscellaneous | 23 temperature | 31 reinspection required |

<p>100 documents</p> <p>101 instruction manual <input type="checkbox"/> <input type="checkbox"/> <input type="checkbox"/> <input type="checkbox"/> <input type="checkbox"/></p> <p>102 spare parts list <input type="checkbox"/> <input type="checkbox"/> <input type="checkbox"/> <input type="checkbox"/> <input type="checkbox"/></p> <p>200 sub frame</p> <p>201 frame connection cpl. <input type="checkbox"/> <input type="checkbox"/> <input type="checkbox"/> <input type="checkbox"/> <input type="checkbox"/></p> <p>300 outrigger front R+L</p> <p>301 transportation safety device <input type="checkbox"/> <input type="checkbox"/> <input type="checkbox"/> <input type="checkbox"/> <input type="checkbox"/></p> <p>302 outrigger <input type="checkbox"/> <input type="checkbox"/> <input type="checkbox"/> <input type="checkbox"/> <input type="checkbox"/></p> <p>303 extension box <input type="checkbox"/> <input type="checkbox"/> <input type="checkbox"/> <input type="checkbox"/> <input type="checkbox"/></p> <p>304 locking device <input type="checkbox"/> <input type="checkbox"/> <input type="checkbox"/> <input type="checkbox"/> <input type="checkbox"/></p> <p>305 slewing bearing <input type="checkbox"/> <input type="checkbox"/> <input type="checkbox"/> <input type="checkbox"/> <input type="checkbox"/></p> <p>306 turn locking device <input type="checkbox"/> <input type="checkbox"/> <input type="checkbox"/> <input type="checkbox"/> <input type="checkbox"/></p> <p>307 support safeguard <input type="checkbox"/> <input type="checkbox"/> <input type="checkbox"/> <input type="checkbox"/> <input type="checkbox"/></p> <p>308 support plate <input type="checkbox"/> <input type="checkbox"/> <input type="checkbox"/> <input type="checkbox"/> <input type="checkbox"/></p> <p>309 fixing of jack cylinder <input type="checkbox"/> <input type="checkbox"/> <input type="checkbox"/> <input type="checkbox"/> <input type="checkbox"/></p> <p>310 jack cylinder <input type="checkbox"/> <input type="checkbox"/> <input type="checkbox"/> <input type="checkbox"/> <input type="checkbox"/></p>	<p>311 swing cylinder <input type="checkbox"/> <input type="checkbox"/> <input type="checkbox"/> <input type="checkbox"/> <input type="checkbox"/></p> <p>312 telescopic-cylinder <input type="checkbox"/> <input type="checkbox"/> <input type="checkbox"/> <input type="checkbox"/> <input type="checkbox"/></p> <p>313 pressure adjustment <input type="checkbox"/> <input type="checkbox"/> <input type="checkbox"/> <input type="checkbox"/> <input type="checkbox"/></p> <p>400 outrigger rear L+R</p> <p>401 transportation safety device <input type="checkbox"/> <input type="checkbox"/> <input type="checkbox"/> <input type="checkbox"/> <input type="checkbox"/></p> <p>402 outrigger <input type="checkbox"/> <input type="checkbox"/> <input type="checkbox"/> <input type="checkbox"/> <input type="checkbox"/></p> <p>403 extension box <input type="checkbox"/> <input type="checkbox"/> <input type="checkbox"/> <input type="checkbox"/> <input type="checkbox"/></p> <p>405 locking device <input type="checkbox"/> <input type="checkbox"/> <input type="checkbox"/> <input type="checkbox"/> <input type="checkbox"/></p> <p>Notes:</p> <hr/> <hr/> <hr/> <hr/> <hr/>
--	---

Inspection report for concrete booms

Inspection report Nr: _____ Boom type: _____ Machine-Nr: _____

- | | | | |
|-------------------------|----------------------------|--------------------------|---------------------------------|
| Error code: | 08 corrosion | 16 porous | 24 deformation |
| 00 no objections | 09 lacquer failures | 17 burned through | 25 bear movement |
| 01 cracks | 10 fraying | 18 not fixed | 26 lubrication |
| 02 broken | 11 scratched | 19 clomp | 27 readability |
| 03 leaky | 12 bendet | 20 sawing | 28 missing components |
| 04 no function | 13 noises | 21 contaminated | 29 hydraulic |
| 05 low lifetime | 14 vibration | 22 bad contact | 30 electrical |
| 06 worn out | 15 miscellaneous | 23 temperature | 31 reinspection required |
| 07 dirt | | | |

<table border="0" style="width: 100%;"> <tr> <td style="width: 30%;">406 slewing bearing</td> <td style="width: 20%; text-align: center;"><input type="checkbox"/></td><td style="text-align: center;"><input type="checkbox"/></td><td style="text-align: center;"><input type="checkbox"/></td><td style="text-align: center;"><input type="checkbox"/></td><td style="text-align: center;"><input type="checkbox"/></td> </tr> <tr> <td>407 turn locking device</td> <td style="text-align: center;"><input type="checkbox"/></td><td style="text-align: center;"><input type="checkbox"/></td><td style="text-align: center;"><input type="checkbox"/></td><td style="text-align: center;"><input type="checkbox"/></td><td style="text-align: center;"><input type="checkbox"/></td> </tr> <tr> <td>408 support safeguard</td> <td style="text-align: center;"><input type="checkbox"/></td><td style="text-align: center;"><input type="checkbox"/></td><td style="text-align: center;"><input type="checkbox"/></td><td style="text-align: center;"><input type="checkbox"/></td><td style="text-align: center;"><input type="checkbox"/></td> </tr> <tr> <td>409 support plate</td> <td style="text-align: center;"><input type="checkbox"/></td><td style="text-align: center;"><input type="checkbox"/></td><td style="text-align: center;"><input type="checkbox"/></td><td style="text-align: center;"><input type="checkbox"/></td><td style="text-align: center;"><input type="checkbox"/></td> </tr> <tr> <td>410 fixing of jack cylinder</td> <td style="text-align: center;"><input type="checkbox"/></td><td style="text-align: center;"><input type="checkbox"/></td><td style="text-align: center;"><input type="checkbox"/></td><td style="text-align: center;"><input type="checkbox"/></td><td style="text-align: center;"><input type="checkbox"/></td> </tr> <tr> <td>411 jack cylinder</td> <td style="text-align: center;"><input type="checkbox"/></td><td style="text-align: center;"><input type="checkbox"/></td><td style="text-align: center;"><input type="checkbox"/></td><td style="text-align: center;"><input type="checkbox"/></td><td style="text-align: center;"><input type="checkbox"/></td> </tr> <tr> <td>412 swing cylinder</td> <td style="text-align: center;"><input type="checkbox"/></td><td style="text-align: center;"><input type="checkbox"/></td><td style="text-align: center;"><input type="checkbox"/></td><td style="text-align: center;"><input type="checkbox"/></td><td style="text-align: center;"><input type="checkbox"/></td> </tr> <tr> <td>413 telescopic cylinder</td> <td style="text-align: center;"><input type="checkbox"/></td><td style="text-align: center;"><input type="checkbox"/></td><td style="text-align: center;"><input type="checkbox"/></td><td style="text-align: center;"><input type="checkbox"/></td><td style="text-align: center;"><input type="checkbox"/></td> </tr> <tr> <td colspan="6">500 pedestal</td> </tr> <tr> <td>501 pedestal mounting</td> <td style="text-align: center;"><input type="checkbox"/></td><td style="text-align: center;"><input type="checkbox"/></td><td style="text-align: center;"><input type="checkbox"/></td><td style="text-align: center;"><input type="checkbox"/></td><td style="text-align: center;"><input type="checkbox"/></td> </tr> <tr> <td>502 sub frame</td> <td style="text-align: center;"><input type="checkbox"/></td><td style="text-align: center;"><input type="checkbox"/></td><td style="text-align: center;"><input type="checkbox"/></td><td style="text-align: center;"><input type="checkbox"/></td><td style="text-align: center;"><input type="checkbox"/></td> </tr> <tr> <td>503 truck frame</td> <td style="text-align: center;"><input type="checkbox"/></td><td style="text-align: center;"><input type="checkbox"/></td><td style="text-align: center;"><input type="checkbox"/></td><td style="text-align: center;"><input type="checkbox"/></td><td style="text-align: center;"><input type="checkbox"/></td> </tr> <tr> <td>504 pedestal (structure)</td> <td style="text-align: center;"><input type="checkbox"/></td><td style="text-align: center;"><input type="checkbox"/></td><td style="text-align: center;"><input type="checkbox"/></td><td style="text-align: center;"><input type="checkbox"/></td><td style="text-align: center;"><input type="checkbox"/></td> </tr> <tr> <td>505 boom valve without leaking</td> <td style="text-align: center;"><input type="checkbox"/></td><td style="text-align: center;"><input type="checkbox"/></td><td style="text-align: center;"><input type="checkbox"/></td><td style="text-align: center;"><input type="checkbox"/></td><td style="text-align: center;"><input type="checkbox"/></td> </tr> <tr> <td>506 boom rest</td> <td style="text-align: center;"><input type="checkbox"/></td><td style="text-align: center;"><input type="checkbox"/></td><td style="text-align: center;"><input type="checkbox"/></td><td style="text-align: center;"><input type="checkbox"/></td><td style="text-align: center;"><input type="checkbox"/></td> </tr> <tr> <td>507 transportation safety device</td> <td style="text-align: center;"><input type="checkbox"/></td><td style="text-align: center;"><input type="checkbox"/></td><td style="text-align: center;"><input type="checkbox"/></td><td style="text-align: center;"><input type="checkbox"/></td><td style="text-align: center;"><input type="checkbox"/></td> </tr> <tr> <td>508 hydraulic line</td> <td style="text-align: center;"><input type="checkbox"/></td><td style="text-align: center;"><input type="checkbox"/></td><td style="text-align: center;"><input type="checkbox"/></td><td style="text-align: center;"><input type="checkbox"/></td><td style="text-align: center;"><input type="checkbox"/></td> </tr> <tr> <td colspan="6">600 slewing head with ball pivot</td> </tr> <tr> <td>601 slewing head</td> <td style="text-align: center;"><input type="checkbox"/></td><td style="text-align: center;"><input type="checkbox"/></td><td style="text-align: center;"><input type="checkbox"/></td><td style="text-align: center;"><input type="checkbox"/></td><td style="text-align: center;"><input type="checkbox"/></td> </tr> <tr> <td>602 ball pivot ring</td> <td style="text-align: center;"><input type="checkbox"/></td><td style="text-align: center;"><input type="checkbox"/></td><td style="text-align: center;"><input type="checkbox"/></td><td style="text-align: center;"><input type="checkbox"/></td><td style="text-align: center;"><input type="checkbox"/></td> </tr> <tr> <td>603 mounting ball pivot ring</td> <td style="text-align: center;"><input type="checkbox"/></td><td style="text-align: center;"><input type="checkbox"/></td><td style="text-align: center;"><input type="checkbox"/></td><td style="text-align: center;"><input type="checkbox"/></td><td style="text-align: center;"><input type="checkbox"/></td> </tr> <tr> <td>604 drive pinion</td> <td style="text-align: center;"><input type="checkbox"/></td><td style="text-align: center;"><input type="checkbox"/></td><td style="text-align: center;"><input type="checkbox"/></td><td style="text-align: center;"><input type="checkbox"/></td><td style="text-align: center;"><input type="checkbox"/></td> </tr> </table>	406 slewing bearing	<input type="checkbox"/>	<input type="checkbox"/>	<input type="checkbox"/>	<input type="checkbox"/>	<input type="checkbox"/>	407 turn locking device	<input type="checkbox"/>	<input type="checkbox"/>	<input type="checkbox"/>	<input type="checkbox"/>	<input type="checkbox"/>	408 support safeguard	<input type="checkbox"/>	<input type="checkbox"/>	<input type="checkbox"/>	<input type="checkbox"/>	<input type="checkbox"/>	409 support plate	<input type="checkbox"/>	<input type="checkbox"/>	<input type="checkbox"/>	<input type="checkbox"/>	<input type="checkbox"/>	410 fixing of jack cylinder	<input type="checkbox"/>	<input type="checkbox"/>	<input type="checkbox"/>	<input type="checkbox"/>	<input type="checkbox"/>	411 jack cylinder	<input type="checkbox"/>	<input type="checkbox"/>	<input type="checkbox"/>	<input type="checkbox"/>	<input type="checkbox"/>	412 swing cylinder	<input type="checkbox"/>	<input type="checkbox"/>	<input type="checkbox"/>	<input type="checkbox"/>	<input type="checkbox"/>	413 telescopic cylinder	<input type="checkbox"/>	<input type="checkbox"/>	<input type="checkbox"/>	<input type="checkbox"/>	<input type="checkbox"/>	500 pedestal						501 pedestal mounting	<input type="checkbox"/>	<input type="checkbox"/>	<input type="checkbox"/>	<input type="checkbox"/>	<input type="checkbox"/>	502 sub frame	<input type="checkbox"/>	<input type="checkbox"/>	<input type="checkbox"/>	<input type="checkbox"/>	<input type="checkbox"/>	503 truck frame	<input type="checkbox"/>	<input type="checkbox"/>	<input type="checkbox"/>	<input type="checkbox"/>	<input type="checkbox"/>	504 pedestal (structure)	<input type="checkbox"/>	<input type="checkbox"/>	<input type="checkbox"/>	<input type="checkbox"/>	<input type="checkbox"/>	505 boom valve without leaking	<input type="checkbox"/>	<input type="checkbox"/>	<input type="checkbox"/>	<input type="checkbox"/>	<input type="checkbox"/>	506 boom rest	<input type="checkbox"/>	<input type="checkbox"/>	<input type="checkbox"/>	<input type="checkbox"/>	<input type="checkbox"/>	507 transportation safety device	<input type="checkbox"/>	<input type="checkbox"/>	<input type="checkbox"/>	<input type="checkbox"/>	<input type="checkbox"/>	508 hydraulic line	<input type="checkbox"/>	<input type="checkbox"/>	<input type="checkbox"/>	<input type="checkbox"/>	<input type="checkbox"/>	600 slewing head with ball pivot						601 slewing head	<input type="checkbox"/>	<input type="checkbox"/>	<input type="checkbox"/>	<input type="checkbox"/>	<input type="checkbox"/>	602 ball pivot ring	<input type="checkbox"/>	<input type="checkbox"/>	<input type="checkbox"/>	<input type="checkbox"/>	<input type="checkbox"/>	603 mounting ball pivot ring	<input type="checkbox"/>	<input type="checkbox"/>	<input type="checkbox"/>	<input type="checkbox"/>	<input type="checkbox"/>	604 drive pinion	<input type="checkbox"/>	<input type="checkbox"/>	<input type="checkbox"/>	<input type="checkbox"/>	<input type="checkbox"/>	<table border="0" style="width: 100%;"> <tr> <td style="width: 30%;">605 slewing drive mounting</td> <td style="width: 20%; text-align: center;"><input type="checkbox"/></td><td style="text-align: center;"><input type="checkbox"/></td><td style="text-align: center;"><input type="checkbox"/></td><td style="text-align: center;"><input type="checkbox"/></td><td style="text-align: center;"><input type="checkbox"/></td> </tr> <tr> <td>606 slewing stop device</td> <td style="text-align: center;"><input type="checkbox"/></td><td style="text-align: center;"><input type="checkbox"/></td><td style="text-align: center;"><input type="checkbox"/></td><td style="text-align: center;"><input type="checkbox"/></td><td style="text-align: center;"><input type="checkbox"/></td> </tr> <tr> <td>607 slewing drive (tooth backlash)</td> <td style="text-align: center;"><input type="checkbox"/></td><td style="text-align: center;"><input type="checkbox"/></td><td style="text-align: center;"><input type="checkbox"/></td><td style="text-align: center;"><input type="checkbox"/></td><td style="text-align: center;"><input type="checkbox"/></td> </tr> <tr> <td>608 slewing drive</td> <td style="text-align: center;"><input type="checkbox"/></td><td style="text-align: center;"><input type="checkbox"/></td><td style="text-align: center;"><input type="checkbox"/></td><td style="text-align: center;"><input type="checkbox"/></td><td style="text-align: center;"><input type="checkbox"/></td> </tr> <tr> <td>609 brake function</td> <td style="text-align: center;"><input type="checkbox"/></td><td style="text-align: center;"><input type="checkbox"/></td><td style="text-align: center;"><input type="checkbox"/></td><td style="text-align: center;"><input type="checkbox"/></td><td style="text-align: center;"><input type="checkbox"/></td> </tr> <tr> <td>610 speed</td> <td style="text-align: center;"><input type="checkbox"/></td><td style="text-align: center;"><input type="checkbox"/></td><td style="text-align: center;"><input type="checkbox"/></td><td style="text-align: center;"><input type="checkbox"/></td><td style="text-align: center;"><input type="checkbox"/></td> </tr> <tr> <td>611 pressure setting</td> <td style="text-align: center;"><input type="checkbox"/></td><td style="text-align: center;"><input type="checkbox"/></td><td style="text-align: center;"><input type="checkbox"/></td><td style="text-align: center;"><input type="checkbox"/></td><td style="text-align: center;"><input type="checkbox"/></td> </tr> <tr> <td>612 hydraulic lines</td> <td style="text-align: center;"><input type="checkbox"/></td><td style="text-align: center;"><input type="checkbox"/></td><td style="text-align: center;"><input type="checkbox"/></td><td style="text-align: center;"><input type="checkbox"/></td><td style="text-align: center;"><input type="checkbox"/></td> </tr> <tr> <td colspan="6">700 slewing head with slewing column</td> </tr> <tr> <td>701 slewing head</td> <td style="text-align: center;"><input type="checkbox"/></td><td style="text-align: center;"><input type="checkbox"/></td><td style="text-align: center;"><input type="checkbox"/></td><td style="text-align: center;"><input type="checkbox"/></td><td style="text-align: center;"><input type="checkbox"/></td> </tr> <tr> <td>702 slewing column bearing</td> <td style="text-align: center;"><input type="checkbox"/></td><td style="text-align: center;"><input type="checkbox"/></td><td style="text-align: center;"><input type="checkbox"/></td><td style="text-align: center;"><input type="checkbox"/></td><td style="text-align: center;"><input type="checkbox"/></td> </tr> <tr> <td>703 slewing drive (tooth backlash)</td> <td style="text-align: center;"><input type="checkbox"/></td><td style="text-align: center;"><input type="checkbox"/></td><td style="text-align: center;"><input type="checkbox"/></td><td style="text-align: center;"><input type="checkbox"/></td><td style="text-align: center;"><input type="checkbox"/></td> </tr> <tr> <td>704 speed</td> <td style="text-align: center;"><input type="checkbox"/></td><td style="text-align: center;"><input type="checkbox"/></td><td style="text-align: center;"><input type="checkbox"/></td><td style="text-align: center;"><input type="checkbox"/></td><td style="text-align: center;"><input type="checkbox"/></td> </tr> <tr> <td>705 pressure settings</td> <td style="text-align: center;"><input type="checkbox"/></td><td style="text-align: center;"><input type="checkbox"/></td><td style="text-align: center;"><input type="checkbox"/></td><td style="text-align: center;"><input type="checkbox"/></td><td style="text-align: center;"><input type="checkbox"/></td> </tr> <tr> <td>706 hydraulic lines</td> <td style="text-align: center;"><input type="checkbox"/></td><td style="text-align: center;"><input type="checkbox"/></td><td style="text-align: center;"><input type="checkbox"/></td><td style="text-align: center;"><input type="checkbox"/></td><td style="text-align: center;"><input type="checkbox"/></td> </tr> <tr> <td>707 swivel cylinder</td> <td style="text-align: center;"><input type="checkbox"/></td><td style="text-align: center;"><input type="checkbox"/></td><td style="text-align: center;"><input type="checkbox"/></td><td style="text-align: center;"><input type="checkbox"/></td><td style="text-align: center;"><input type="checkbox"/></td> </tr> </table> <p>Notes:</p> <hr/> <hr/> <hr/> <hr/>	605 slewing drive mounting	<input type="checkbox"/>	<input type="checkbox"/>	<input type="checkbox"/>	<input type="checkbox"/>	<input type="checkbox"/>	606 slewing stop device	<input type="checkbox"/>	<input type="checkbox"/>	<input type="checkbox"/>	<input type="checkbox"/>	<input type="checkbox"/>	607 slewing drive (tooth backlash)	<input type="checkbox"/>	<input type="checkbox"/>	<input type="checkbox"/>	<input type="checkbox"/>	<input type="checkbox"/>	608 slewing drive	<input type="checkbox"/>	<input type="checkbox"/>	<input type="checkbox"/>	<input type="checkbox"/>	<input type="checkbox"/>	609 brake function	<input type="checkbox"/>	<input type="checkbox"/>	<input type="checkbox"/>	<input type="checkbox"/>	<input type="checkbox"/>	610 speed	<input type="checkbox"/>	<input type="checkbox"/>	<input type="checkbox"/>	<input type="checkbox"/>	<input type="checkbox"/>	611 pressure setting	<input type="checkbox"/>	<input type="checkbox"/>	<input type="checkbox"/>	<input type="checkbox"/>	<input type="checkbox"/>	612 hydraulic lines	<input type="checkbox"/>	<input type="checkbox"/>	<input type="checkbox"/>	<input type="checkbox"/>	<input type="checkbox"/>	700 slewing head with slewing column						701 slewing head	<input type="checkbox"/>	<input type="checkbox"/>	<input type="checkbox"/>	<input type="checkbox"/>	<input type="checkbox"/>	702 slewing column bearing	<input type="checkbox"/>	<input type="checkbox"/>	<input type="checkbox"/>	<input type="checkbox"/>	<input type="checkbox"/>	703 slewing drive (tooth backlash)	<input type="checkbox"/>	<input type="checkbox"/>	<input type="checkbox"/>	<input type="checkbox"/>	<input type="checkbox"/>	704 speed	<input type="checkbox"/>	<input type="checkbox"/>	<input type="checkbox"/>	<input type="checkbox"/>	<input type="checkbox"/>	705 pressure settings	<input type="checkbox"/>	<input type="checkbox"/>	<input type="checkbox"/>	<input type="checkbox"/>	<input type="checkbox"/>	706 hydraulic lines	<input type="checkbox"/>	<input type="checkbox"/>	<input type="checkbox"/>	<input type="checkbox"/>	<input type="checkbox"/>	707 swivel cylinder	<input type="checkbox"/>	<input type="checkbox"/>	<input type="checkbox"/>	<input type="checkbox"/>	<input type="checkbox"/>
406 slewing bearing	<input type="checkbox"/>	<input type="checkbox"/>	<input type="checkbox"/>	<input type="checkbox"/>	<input type="checkbox"/>																																																																																																																																																																																																																																
407 turn locking device	<input type="checkbox"/>	<input type="checkbox"/>	<input type="checkbox"/>	<input type="checkbox"/>	<input type="checkbox"/>																																																																																																																																																																																																																																
408 support safeguard	<input type="checkbox"/>	<input type="checkbox"/>	<input type="checkbox"/>	<input type="checkbox"/>	<input type="checkbox"/>																																																																																																																																																																																																																																
409 support plate	<input type="checkbox"/>	<input type="checkbox"/>	<input type="checkbox"/>	<input type="checkbox"/>	<input type="checkbox"/>																																																																																																																																																																																																																																
410 fixing of jack cylinder	<input type="checkbox"/>	<input type="checkbox"/>	<input type="checkbox"/>	<input type="checkbox"/>	<input type="checkbox"/>																																																																																																																																																																																																																																
411 jack cylinder	<input type="checkbox"/>	<input type="checkbox"/>	<input type="checkbox"/>	<input type="checkbox"/>	<input type="checkbox"/>																																																																																																																																																																																																																																
412 swing cylinder	<input type="checkbox"/>	<input type="checkbox"/>	<input type="checkbox"/>	<input type="checkbox"/>	<input type="checkbox"/>																																																																																																																																																																																																																																
413 telescopic cylinder	<input type="checkbox"/>	<input type="checkbox"/>	<input type="checkbox"/>	<input type="checkbox"/>	<input type="checkbox"/>																																																																																																																																																																																																																																
500 pedestal																																																																																																																																																																																																																																					
501 pedestal mounting	<input type="checkbox"/>	<input type="checkbox"/>	<input type="checkbox"/>	<input type="checkbox"/>	<input type="checkbox"/>																																																																																																																																																																																																																																
502 sub frame	<input type="checkbox"/>	<input type="checkbox"/>	<input type="checkbox"/>	<input type="checkbox"/>	<input type="checkbox"/>																																																																																																																																																																																																																																
503 truck frame	<input type="checkbox"/>	<input type="checkbox"/>	<input type="checkbox"/>	<input type="checkbox"/>	<input type="checkbox"/>																																																																																																																																																																																																																																
504 pedestal (structure)	<input type="checkbox"/>	<input type="checkbox"/>	<input type="checkbox"/>	<input type="checkbox"/>	<input type="checkbox"/>																																																																																																																																																																																																																																
505 boom valve without leaking	<input type="checkbox"/>	<input type="checkbox"/>	<input type="checkbox"/>	<input type="checkbox"/>	<input type="checkbox"/>																																																																																																																																																																																																																																
506 boom rest	<input type="checkbox"/>	<input type="checkbox"/>	<input type="checkbox"/>	<input type="checkbox"/>	<input type="checkbox"/>																																																																																																																																																																																																																																
507 transportation safety device	<input type="checkbox"/>	<input type="checkbox"/>	<input type="checkbox"/>	<input type="checkbox"/>	<input type="checkbox"/>																																																																																																																																																																																																																																
508 hydraulic line	<input type="checkbox"/>	<input type="checkbox"/>	<input type="checkbox"/>	<input type="checkbox"/>	<input type="checkbox"/>																																																																																																																																																																																																																																
600 slewing head with ball pivot																																																																																																																																																																																																																																					
601 slewing head	<input type="checkbox"/>	<input type="checkbox"/>	<input type="checkbox"/>	<input type="checkbox"/>	<input type="checkbox"/>																																																																																																																																																																																																																																
602 ball pivot ring	<input type="checkbox"/>	<input type="checkbox"/>	<input type="checkbox"/>	<input type="checkbox"/>	<input type="checkbox"/>																																																																																																																																																																																																																																
603 mounting ball pivot ring	<input type="checkbox"/>	<input type="checkbox"/>	<input type="checkbox"/>	<input type="checkbox"/>	<input type="checkbox"/>																																																																																																																																																																																																																																
604 drive pinion	<input type="checkbox"/>	<input type="checkbox"/>	<input type="checkbox"/>	<input type="checkbox"/>	<input type="checkbox"/>																																																																																																																																																																																																																																
605 slewing drive mounting	<input type="checkbox"/>	<input type="checkbox"/>	<input type="checkbox"/>	<input type="checkbox"/>	<input type="checkbox"/>																																																																																																																																																																																																																																
606 slewing stop device	<input type="checkbox"/>	<input type="checkbox"/>	<input type="checkbox"/>	<input type="checkbox"/>	<input type="checkbox"/>																																																																																																																																																																																																																																
607 slewing drive (tooth backlash)	<input type="checkbox"/>	<input type="checkbox"/>	<input type="checkbox"/>	<input type="checkbox"/>	<input type="checkbox"/>																																																																																																																																																																																																																																
608 slewing drive	<input type="checkbox"/>	<input type="checkbox"/>	<input type="checkbox"/>	<input type="checkbox"/>	<input type="checkbox"/>																																																																																																																																																																																																																																
609 brake function	<input type="checkbox"/>	<input type="checkbox"/>	<input type="checkbox"/>	<input type="checkbox"/>	<input type="checkbox"/>																																																																																																																																																																																																																																
610 speed	<input type="checkbox"/>	<input type="checkbox"/>	<input type="checkbox"/>	<input type="checkbox"/>	<input type="checkbox"/>																																																																																																																																																																																																																																
611 pressure setting	<input type="checkbox"/>	<input type="checkbox"/>	<input type="checkbox"/>	<input type="checkbox"/>	<input type="checkbox"/>																																																																																																																																																																																																																																
612 hydraulic lines	<input type="checkbox"/>	<input type="checkbox"/>	<input type="checkbox"/>	<input type="checkbox"/>	<input type="checkbox"/>																																																																																																																																																																																																																																
700 slewing head with slewing column																																																																																																																																																																																																																																					
701 slewing head	<input type="checkbox"/>	<input type="checkbox"/>	<input type="checkbox"/>	<input type="checkbox"/>	<input type="checkbox"/>																																																																																																																																																																																																																																
702 slewing column bearing	<input type="checkbox"/>	<input type="checkbox"/>	<input type="checkbox"/>	<input type="checkbox"/>	<input type="checkbox"/>																																																																																																																																																																																																																																
703 slewing drive (tooth backlash)	<input type="checkbox"/>	<input type="checkbox"/>	<input type="checkbox"/>	<input type="checkbox"/>	<input type="checkbox"/>																																																																																																																																																																																																																																
704 speed	<input type="checkbox"/>	<input type="checkbox"/>	<input type="checkbox"/>	<input type="checkbox"/>	<input type="checkbox"/>																																																																																																																																																																																																																																
705 pressure settings	<input type="checkbox"/>	<input type="checkbox"/>	<input type="checkbox"/>	<input type="checkbox"/>	<input type="checkbox"/>																																																																																																																																																																																																																																
706 hydraulic lines	<input type="checkbox"/>	<input type="checkbox"/>	<input type="checkbox"/>	<input type="checkbox"/>	<input type="checkbox"/>																																																																																																																																																																																																																																
707 swivel cylinder	<input type="checkbox"/>	<input type="checkbox"/>	<input type="checkbox"/>	<input type="checkbox"/>	<input type="checkbox"/>																																																																																																																																																																																																																																

Inspection report for concrete booms

Inspection report Nr: _____ Boom type: _____ Machine-Nr: _____

- | | | | |
|------------------|---------------------|-------------------|--------------------------|
| Error code: | | | |
| 00 no objections | 08 corrosion | 16 porous | 24 deformation |
| 01 cracks | 09 lacquer failures | 17 burned through | 25 bear movement |
| 02 broken | 10 fraying | 18 not fixed | 26 lubrication |
| 03 leaky | 11 scratched | 19 clomp | 27 readability |
| 04 no function | 12 bendet | 20 sawing | 28 missing components |
| 05 low lifetime | 13 noises | 21 contaminated | 29 hydraulical |
| 06 worn out | 14 vibration | 22 bad contact | 30 electrical |
| 07 dirt | 15 miscellaneous | 23 temperature | 31 reinspection required |

<table border="0" style="width: 100%;"> <tr> <td style="width: 30%;">800 boom</td> <td style="width: 20%;"><input type="checkbox"/></td> <td style="width: 20%;"><input type="checkbox"/></td> <td style="width: 20%;"><input type="checkbox"/></td> <td style="width: 20%;"><input type="checkbox"/></td> <td style="width: 20%;"><input type="checkbox"/></td> </tr> <tr> <td>801 „Arm1“</td> <td><input type="checkbox"/></td> <td><input type="checkbox"/></td> <td><input type="checkbox"/></td> <td><input type="checkbox"/></td> <td><input type="checkbox"/></td> </tr> <tr> <td>802 bracket conveying line</td> <td><input type="checkbox"/></td> <td><input type="checkbox"/></td> <td><input type="checkbox"/></td> <td><input type="checkbox"/></td> <td><input type="checkbox"/></td> </tr> <tr> <td>803 Drop hook</td> <td><input type="checkbox"/></td> <td><input type="checkbox"/></td> <td><input type="checkbox"/></td> <td><input type="checkbox"/></td> <td><input type="checkbox"/></td> </tr> <tr> <td>804 „Arm 2“</td> <td><input type="checkbox"/></td> <td><input type="checkbox"/></td> <td><input type="checkbox"/></td> <td><input type="checkbox"/></td> <td><input type="checkbox"/></td> </tr> <tr> <td>805 bracket conveying line</td> <td><input type="checkbox"/></td> <td><input type="checkbox"/></td> <td><input type="checkbox"/></td> <td><input type="checkbox"/></td> <td><input type="checkbox"/></td> </tr> <tr> <td>806 Drop hook</td> <td><input type="checkbox"/></td> <td><input type="checkbox"/></td> <td><input type="checkbox"/></td> <td><input type="checkbox"/></td> <td><input type="checkbox"/></td> </tr> <tr> <td>807 „Arm 3“</td> <td><input type="checkbox"/></td> <td><input type="checkbox"/></td> <td><input type="checkbox"/></td> <td><input type="checkbox"/></td> <td><input type="checkbox"/></td> </tr> <tr> <td>808 bracket conveying line</td> <td><input type="checkbox"/></td> <td><input type="checkbox"/></td> <td><input type="checkbox"/></td> <td><input type="checkbox"/></td> <td><input type="checkbox"/></td> </tr> <tr> <td>809 guidance and interlock of the arm</td> <td><input type="checkbox"/></td> <td><input type="checkbox"/></td> <td><input type="checkbox"/></td> <td><input type="checkbox"/></td> <td><input type="checkbox"/></td> </tr> <tr> <td>810 „Arm 4“</td> <td><input type="checkbox"/></td> <td><input type="checkbox"/></td> <td><input type="checkbox"/></td> <td><input type="checkbox"/></td> <td><input type="checkbox"/></td> </tr> <tr> <td>811 bracket conveying line</td> <td><input type="checkbox"/></td> <td><input type="checkbox"/></td> <td><input type="checkbox"/></td> <td><input type="checkbox"/></td> <td><input type="checkbox"/></td> </tr> <tr> <td>812 guidance and interlock of the arm</td> <td><input type="checkbox"/></td> <td><input type="checkbox"/></td> <td><input type="checkbox"/></td> <td><input type="checkbox"/></td> <td><input type="checkbox"/></td> </tr> <tr> <td>813 „Arm 5“</td> <td><input type="checkbox"/></td> <td><input type="checkbox"/></td> <td><input type="checkbox"/></td> <td><input type="checkbox"/></td> <td><input type="checkbox"/></td> </tr> <tr> <td>814 bracket conveying line</td> <td><input type="checkbox"/></td> <td><input type="checkbox"/></td> <td><input type="checkbox"/></td> <td><input type="checkbox"/></td> <td><input type="checkbox"/></td> </tr> <tr> <td>815 guidance and interlock of the arm</td> <td><input type="checkbox"/></td> <td><input type="checkbox"/></td> <td><input type="checkbox"/></td> <td><input type="checkbox"/></td> <td><input type="checkbox"/></td> </tr> <tr> <td>900 joint „A“</td> <td><input type="checkbox"/></td> <td><input type="checkbox"/></td> <td><input type="checkbox"/></td> <td><input type="checkbox"/></td> <td><input type="checkbox"/></td> </tr> <tr> <td>901 boom</td> <td><input type="checkbox"/></td> <td><input type="checkbox"/></td> <td><input type="checkbox"/></td> <td><input type="checkbox"/></td> <td><input type="checkbox"/></td> </tr> <tr> <td>902 link lever</td> <td><input type="checkbox"/></td> <td><input type="checkbox"/></td> <td><input type="checkbox"/></td> <td><input type="checkbox"/></td> <td><input type="checkbox"/></td> </tr> <tr> <td>903 forcing rod</td> <td><input type="checkbox"/></td> <td><input type="checkbox"/></td> <td><input type="checkbox"/></td> <td><input type="checkbox"/></td> <td><input type="checkbox"/></td> </tr> <tr> <td>904 pin</td> <td><input type="checkbox"/></td> <td><input type="checkbox"/></td> <td><input type="checkbox"/></td> <td><input type="checkbox"/></td> <td><input type="checkbox"/></td> </tr> <tr> <td>905 cylinder</td> <td><input type="checkbox"/></td> <td><input type="checkbox"/></td> <td><input type="checkbox"/></td> <td><input type="checkbox"/></td> <td><input type="checkbox"/></td> </tr> </table>	800 boom	<input type="checkbox"/>	<input type="checkbox"/>	<input type="checkbox"/>	<input type="checkbox"/>	<input type="checkbox"/>	801 „Arm1“	<input type="checkbox"/>	<input type="checkbox"/>	<input type="checkbox"/>	<input type="checkbox"/>	<input type="checkbox"/>	802 bracket conveying line	<input type="checkbox"/>	<input type="checkbox"/>	<input type="checkbox"/>	<input type="checkbox"/>	<input type="checkbox"/>	803 Drop hook	<input type="checkbox"/>	<input type="checkbox"/>	<input type="checkbox"/>	<input type="checkbox"/>	<input type="checkbox"/>	804 „Arm 2“	<input type="checkbox"/>	<input type="checkbox"/>	<input type="checkbox"/>	<input type="checkbox"/>	<input type="checkbox"/>	805 bracket conveying line	<input type="checkbox"/>	<input type="checkbox"/>	<input type="checkbox"/>	<input type="checkbox"/>	<input type="checkbox"/>	806 Drop hook	<input type="checkbox"/>	<input type="checkbox"/>	<input type="checkbox"/>	<input type="checkbox"/>	<input type="checkbox"/>	807 „Arm 3“	<input type="checkbox"/>	<input type="checkbox"/>	<input type="checkbox"/>	<input type="checkbox"/>	<input type="checkbox"/>	808 bracket conveying line	<input type="checkbox"/>	<input type="checkbox"/>	<input type="checkbox"/>	<input type="checkbox"/>	<input type="checkbox"/>	809 guidance and interlock of the arm	<input type="checkbox"/>	<input type="checkbox"/>	<input type="checkbox"/>	<input type="checkbox"/>	<input type="checkbox"/>	810 „Arm 4“	<input type="checkbox"/>	<input type="checkbox"/>	<input type="checkbox"/>	<input type="checkbox"/>	<input type="checkbox"/>	811 bracket conveying line	<input type="checkbox"/>	<input type="checkbox"/>	<input type="checkbox"/>	<input type="checkbox"/>	<input type="checkbox"/>	812 guidance and interlock of the arm	<input type="checkbox"/>	<input type="checkbox"/>	<input type="checkbox"/>	<input type="checkbox"/>	<input type="checkbox"/>	813 „Arm 5“	<input type="checkbox"/>	<input type="checkbox"/>	<input type="checkbox"/>	<input type="checkbox"/>	<input type="checkbox"/>	814 bracket conveying line	<input type="checkbox"/>	<input type="checkbox"/>	<input type="checkbox"/>	<input type="checkbox"/>	<input type="checkbox"/>	815 guidance and interlock of the arm	<input type="checkbox"/>	<input type="checkbox"/>	<input type="checkbox"/>	<input type="checkbox"/>	<input type="checkbox"/>	900 joint „A“	<input type="checkbox"/>	<input type="checkbox"/>	<input type="checkbox"/>	<input type="checkbox"/>	<input type="checkbox"/>	901 boom	<input type="checkbox"/>	<input type="checkbox"/>	<input type="checkbox"/>	<input type="checkbox"/>	<input type="checkbox"/>	902 link lever	<input type="checkbox"/>	<input type="checkbox"/>	<input type="checkbox"/>	<input type="checkbox"/>	<input type="checkbox"/>	903 forcing rod	<input type="checkbox"/>	<input type="checkbox"/>	<input type="checkbox"/>	<input type="checkbox"/>	<input type="checkbox"/>	904 pin	<input type="checkbox"/>	<input type="checkbox"/>	<input type="checkbox"/>	<input type="checkbox"/>	<input type="checkbox"/>	905 cylinder	<input type="checkbox"/>	<input type="checkbox"/>	<input type="checkbox"/>	<input type="checkbox"/>	<input type="checkbox"/>	<table border="0" style="width: 100%;"> <tr> <td style="width: 30%;">906 boom speed</td> <td style="width: 20%;"><input type="checkbox"/></td> <td style="width: 20%;"><input type="checkbox"/></td> <td style="width: 20%;"><input type="checkbox"/></td> <td style="width: 20%;"><input type="checkbox"/></td> <td style="width: 20%;"><input type="checkbox"/></td> </tr> <tr> <td>907 pressure settings</td> <td><input type="checkbox"/></td> <td><input type="checkbox"/></td> <td><input type="checkbox"/></td> <td><input type="checkbox"/></td> <td><input type="checkbox"/></td> </tr> <tr> <td>908 hydraulic lines</td> <td><input type="checkbox"/></td> <td><input type="checkbox"/></td> <td><input type="checkbox"/></td> <td><input type="checkbox"/></td> <td><input type="checkbox"/></td> </tr> <tr> <td>909 load holding valve (piston side)</td> <td><input type="checkbox"/></td> <td><input type="checkbox"/></td> <td><input type="checkbox"/></td> <td><input type="checkbox"/></td> <td><input type="checkbox"/></td> </tr> <tr> <td>910 load holding valve (rod side)</td> <td><input type="checkbox"/></td> <td><input type="checkbox"/></td> <td><input type="checkbox"/></td> <td><input type="checkbox"/></td> <td><input type="checkbox"/></td> </tr> <tr> <td>1000 joint „B“</td> <td></td> <td></td> <td></td> <td></td> <td></td> </tr> <tr> <td>1001 boom</td> <td><input type="checkbox"/></td> <td><input type="checkbox"/></td> <td><input type="checkbox"/></td> <td><input type="checkbox"/></td> <td><input type="checkbox"/></td> </tr> <tr> <td>1002 link lever</td> <td><input type="checkbox"/></td> <td><input type="checkbox"/></td> <td><input type="checkbox"/></td> <td><input type="checkbox"/></td> <td><input type="checkbox"/></td> </tr> <tr> <td>1003 forcing rod</td> <td><input type="checkbox"/></td> <td><input type="checkbox"/></td> <td><input type="checkbox"/></td> <td><input type="checkbox"/></td> <td><input type="checkbox"/></td> </tr> <tr> <td>1004 pin</td> <td><input type="checkbox"/></td> <td><input type="checkbox"/></td> <td><input type="checkbox"/></td> <td><input type="checkbox"/></td> <td><input type="checkbox"/></td> </tr> <tr> <td>1005 cylinder</td> <td><input type="checkbox"/></td> <td><input type="checkbox"/></td> <td><input type="checkbox"/></td> <td><input type="checkbox"/></td> <td><input type="checkbox"/></td> </tr> <tr> <td>1006 boom speed</td> <td><input type="checkbox"/></td> <td><input type="checkbox"/></td> <td><input type="checkbox"/></td> <td><input type="checkbox"/></td> <td><input type="checkbox"/></td> </tr> <tr> <td>1007 pressure settings</td> <td><input type="checkbox"/></td> <td><input type="checkbox"/></td> <td><input type="checkbox"/></td> <td><input type="checkbox"/></td> <td><input type="checkbox"/></td> </tr> <tr> <td>1008 hydraulic lines</td> <td><input type="checkbox"/></td> <td><input type="checkbox"/></td> <td><input type="checkbox"/></td> <td><input type="checkbox"/></td> <td><input type="checkbox"/></td> </tr> <tr> <td>1009 load holding valve (piston side)</td> <td><input type="checkbox"/></td> <td><input type="checkbox"/></td> <td><input type="checkbox"/></td> <td><input type="checkbox"/></td> <td><input type="checkbox"/></td> </tr> <tr> <td>1010 load holding valve (rod side)</td> <td><input type="checkbox"/></td> <td><input type="checkbox"/></td> <td><input type="checkbox"/></td> <td><input type="checkbox"/></td> <td><input type="checkbox"/></td> </tr> <tr> <td>Notes:</td> <td colspan="5" style="border: none;"> <div style="border: 1px solid black; height: 40px; margin-bottom: 5px;"></div> <div style="border: 1px solid black; height: 40px; margin-bottom: 5px;"></div> <div style="border: 1px solid black; height: 40px; margin-bottom: 5px;"></div> <div style="border: 1px solid black; height: 40px;"></div> </td> </tr> </table>	906 boom speed	<input type="checkbox"/>	<input type="checkbox"/>	<input type="checkbox"/>	<input type="checkbox"/>	<input type="checkbox"/>	907 pressure settings	<input type="checkbox"/>	<input type="checkbox"/>	<input type="checkbox"/>	<input type="checkbox"/>	<input type="checkbox"/>	908 hydraulic lines	<input type="checkbox"/>	<input type="checkbox"/>	<input type="checkbox"/>	<input type="checkbox"/>	<input type="checkbox"/>	909 load holding valve (piston side)	<input type="checkbox"/>	<input type="checkbox"/>	<input type="checkbox"/>	<input type="checkbox"/>	<input type="checkbox"/>	910 load holding valve (rod side)	<input type="checkbox"/>	<input type="checkbox"/>	<input type="checkbox"/>	<input type="checkbox"/>	<input type="checkbox"/>	1000 joint „B“						1001 boom	<input type="checkbox"/>	<input type="checkbox"/>	<input type="checkbox"/>	<input type="checkbox"/>	<input type="checkbox"/>	1002 link lever	<input type="checkbox"/>	<input type="checkbox"/>	<input type="checkbox"/>	<input type="checkbox"/>	<input type="checkbox"/>	1003 forcing rod	<input type="checkbox"/>	<input type="checkbox"/>	<input type="checkbox"/>	<input type="checkbox"/>	<input type="checkbox"/>	1004 pin	<input type="checkbox"/>	<input type="checkbox"/>	<input type="checkbox"/>	<input type="checkbox"/>	<input type="checkbox"/>	1005 cylinder	<input type="checkbox"/>	<input type="checkbox"/>	<input type="checkbox"/>	<input type="checkbox"/>	<input type="checkbox"/>	1006 boom speed	<input type="checkbox"/>	<input type="checkbox"/>	<input type="checkbox"/>	<input type="checkbox"/>	<input type="checkbox"/>	1007 pressure settings	<input type="checkbox"/>	<input type="checkbox"/>	<input type="checkbox"/>	<input type="checkbox"/>	<input type="checkbox"/>	1008 hydraulic lines	<input type="checkbox"/>	<input type="checkbox"/>	<input type="checkbox"/>	<input type="checkbox"/>	<input type="checkbox"/>	1009 load holding valve (piston side)	<input type="checkbox"/>	<input type="checkbox"/>	<input type="checkbox"/>	<input type="checkbox"/>	<input type="checkbox"/>	1010 load holding valve (rod side)	<input type="checkbox"/>	<input type="checkbox"/>	<input type="checkbox"/>	<input type="checkbox"/>	<input type="checkbox"/>	Notes:	<div style="border: 1px solid black; height: 40px; margin-bottom: 5px;"></div> <div style="border: 1px solid black; height: 40px; margin-bottom: 5px;"></div> <div style="border: 1px solid black; height: 40px; margin-bottom: 5px;"></div> <div style="border: 1px solid black; height: 40px;"></div>				
800 boom	<input type="checkbox"/>	<input type="checkbox"/>	<input type="checkbox"/>	<input type="checkbox"/>	<input type="checkbox"/>																																																																																																																																																																																																																																						
801 „Arm1“	<input type="checkbox"/>	<input type="checkbox"/>	<input type="checkbox"/>	<input type="checkbox"/>	<input type="checkbox"/>																																																																																																																																																																																																																																						
802 bracket conveying line	<input type="checkbox"/>	<input type="checkbox"/>	<input type="checkbox"/>	<input type="checkbox"/>	<input type="checkbox"/>																																																																																																																																																																																																																																						
803 Drop hook	<input type="checkbox"/>	<input type="checkbox"/>	<input type="checkbox"/>	<input type="checkbox"/>	<input type="checkbox"/>																																																																																																																																																																																																																																						
804 „Arm 2“	<input type="checkbox"/>	<input type="checkbox"/>	<input type="checkbox"/>	<input type="checkbox"/>	<input type="checkbox"/>																																																																																																																																																																																																																																						
805 bracket conveying line	<input type="checkbox"/>	<input type="checkbox"/>	<input type="checkbox"/>	<input type="checkbox"/>	<input type="checkbox"/>																																																																																																																																																																																																																																						
806 Drop hook	<input type="checkbox"/>	<input type="checkbox"/>	<input type="checkbox"/>	<input type="checkbox"/>	<input type="checkbox"/>																																																																																																																																																																																																																																						
807 „Arm 3“	<input type="checkbox"/>	<input type="checkbox"/>	<input type="checkbox"/>	<input type="checkbox"/>	<input type="checkbox"/>																																																																																																																																																																																																																																						
808 bracket conveying line	<input type="checkbox"/>	<input type="checkbox"/>	<input type="checkbox"/>	<input type="checkbox"/>	<input type="checkbox"/>																																																																																																																																																																																																																																						
809 guidance and interlock of the arm	<input type="checkbox"/>	<input type="checkbox"/>	<input type="checkbox"/>	<input type="checkbox"/>	<input type="checkbox"/>																																																																																																																																																																																																																																						
810 „Arm 4“	<input type="checkbox"/>	<input type="checkbox"/>	<input type="checkbox"/>	<input type="checkbox"/>	<input type="checkbox"/>																																																																																																																																																																																																																																						
811 bracket conveying line	<input type="checkbox"/>	<input type="checkbox"/>	<input type="checkbox"/>	<input type="checkbox"/>	<input type="checkbox"/>																																																																																																																																																																																																																																						
812 guidance and interlock of the arm	<input type="checkbox"/>	<input type="checkbox"/>	<input type="checkbox"/>	<input type="checkbox"/>	<input type="checkbox"/>																																																																																																																																																																																																																																						
813 „Arm 5“	<input type="checkbox"/>	<input type="checkbox"/>	<input type="checkbox"/>	<input type="checkbox"/>	<input type="checkbox"/>																																																																																																																																																																																																																																						
814 bracket conveying line	<input type="checkbox"/>	<input type="checkbox"/>	<input type="checkbox"/>	<input type="checkbox"/>	<input type="checkbox"/>																																																																																																																																																																																																																																						
815 guidance and interlock of the arm	<input type="checkbox"/>	<input type="checkbox"/>	<input type="checkbox"/>	<input type="checkbox"/>	<input type="checkbox"/>																																																																																																																																																																																																																																						
900 joint „A“	<input type="checkbox"/>	<input type="checkbox"/>	<input type="checkbox"/>	<input type="checkbox"/>	<input type="checkbox"/>																																																																																																																																																																																																																																						
901 boom	<input type="checkbox"/>	<input type="checkbox"/>	<input type="checkbox"/>	<input type="checkbox"/>	<input type="checkbox"/>																																																																																																																																																																																																																																						
902 link lever	<input type="checkbox"/>	<input type="checkbox"/>	<input type="checkbox"/>	<input type="checkbox"/>	<input type="checkbox"/>																																																																																																																																																																																																																																						
903 forcing rod	<input type="checkbox"/>	<input type="checkbox"/>	<input type="checkbox"/>	<input type="checkbox"/>	<input type="checkbox"/>																																																																																																																																																																																																																																						
904 pin	<input type="checkbox"/>	<input type="checkbox"/>	<input type="checkbox"/>	<input type="checkbox"/>	<input type="checkbox"/>																																																																																																																																																																																																																																						
905 cylinder	<input type="checkbox"/>	<input type="checkbox"/>	<input type="checkbox"/>	<input type="checkbox"/>	<input type="checkbox"/>																																																																																																																																																																																																																																						
906 boom speed	<input type="checkbox"/>	<input type="checkbox"/>	<input type="checkbox"/>	<input type="checkbox"/>	<input type="checkbox"/>																																																																																																																																																																																																																																						
907 pressure settings	<input type="checkbox"/>	<input type="checkbox"/>	<input type="checkbox"/>	<input type="checkbox"/>	<input type="checkbox"/>																																																																																																																																																																																																																																						
908 hydraulic lines	<input type="checkbox"/>	<input type="checkbox"/>	<input type="checkbox"/>	<input type="checkbox"/>	<input type="checkbox"/>																																																																																																																																																																																																																																						
909 load holding valve (piston side)	<input type="checkbox"/>	<input type="checkbox"/>	<input type="checkbox"/>	<input type="checkbox"/>	<input type="checkbox"/>																																																																																																																																																																																																																																						
910 load holding valve (rod side)	<input type="checkbox"/>	<input type="checkbox"/>	<input type="checkbox"/>	<input type="checkbox"/>	<input type="checkbox"/>																																																																																																																																																																																																																																						
1000 joint „B“																																																																																																																																																																																																																																											
1001 boom	<input type="checkbox"/>	<input type="checkbox"/>	<input type="checkbox"/>	<input type="checkbox"/>	<input type="checkbox"/>																																																																																																																																																																																																																																						
1002 link lever	<input type="checkbox"/>	<input type="checkbox"/>	<input type="checkbox"/>	<input type="checkbox"/>	<input type="checkbox"/>																																																																																																																																																																																																																																						
1003 forcing rod	<input type="checkbox"/>	<input type="checkbox"/>	<input type="checkbox"/>	<input type="checkbox"/>	<input type="checkbox"/>																																																																																																																																																																																																																																						
1004 pin	<input type="checkbox"/>	<input type="checkbox"/>	<input type="checkbox"/>	<input type="checkbox"/>	<input type="checkbox"/>																																																																																																																																																																																																																																						
1005 cylinder	<input type="checkbox"/>	<input type="checkbox"/>	<input type="checkbox"/>	<input type="checkbox"/>	<input type="checkbox"/>																																																																																																																																																																																																																																						
1006 boom speed	<input type="checkbox"/>	<input type="checkbox"/>	<input type="checkbox"/>	<input type="checkbox"/>	<input type="checkbox"/>																																																																																																																																																																																																																																						
1007 pressure settings	<input type="checkbox"/>	<input type="checkbox"/>	<input type="checkbox"/>	<input type="checkbox"/>	<input type="checkbox"/>																																																																																																																																																																																																																																						
1008 hydraulic lines	<input type="checkbox"/>	<input type="checkbox"/>	<input type="checkbox"/>	<input type="checkbox"/>	<input type="checkbox"/>																																																																																																																																																																																																																																						
1009 load holding valve (piston side)	<input type="checkbox"/>	<input type="checkbox"/>	<input type="checkbox"/>	<input type="checkbox"/>	<input type="checkbox"/>																																																																																																																																																																																																																																						
1010 load holding valve (rod side)	<input type="checkbox"/>	<input type="checkbox"/>	<input type="checkbox"/>	<input type="checkbox"/>	<input type="checkbox"/>																																																																																																																																																																																																																																						
Notes:	<div style="border: 1px solid black; height: 40px; margin-bottom: 5px;"></div> <div style="border: 1px solid black; height: 40px; margin-bottom: 5px;"></div> <div style="border: 1px solid black; height: 40px; margin-bottom: 5px;"></div> <div style="border: 1px solid black; height: 40px;"></div>																																																																																																																																																																																																																																										

Inspection report for concrete booms

Inspection report Nr: _____ Boom type: _____ Machine-Nr: _____

- | | | | |
|------------------|---------------------|-------------------|--------------------------|
| Error code: | | | |
| 00 no objections | 08 corrosion | 16 porous | 24 deformation |
| 01 cracks | 09 lacquer failures | 17 burned through | 25 bear movement |
| 02 broken | 10 fraying | 18 not fixed | 26 lubrication |
| 03 leaky | 11 scratched | 19 clomp | 27 readability |
| 04 no function | 12 bendet | 20 sawing | 28 missing components |
| 05 low lifetime | 13 noises | 21 contaminated | 29 hydraulic |
| 06 worn out | 14 vibration | 22 bad contact | 30 electrical |
| 07 dirt | 15 miscellaneous | 23 temperature | 31 reinspection required |

<p>1100 joint "C"</p> <p>1101 boom <input type="checkbox"/> <input type="checkbox"/> <input type="checkbox"/> <input type="checkbox"/> <input type="checkbox"/></p> <p>1102 link lever <input type="checkbox"/> <input type="checkbox"/> <input type="checkbox"/> <input type="checkbox"/> <input type="checkbox"/></p> <p>1103 forcing rod <input type="checkbox"/> <input type="checkbox"/> <input type="checkbox"/> <input type="checkbox"/> <input type="checkbox"/></p> <p>1104 pin <input type="checkbox"/> <input type="checkbox"/> <input type="checkbox"/> <input type="checkbox"/> <input type="checkbox"/></p> <p>1105 cylinder <input type="checkbox"/> <input type="checkbox"/> <input type="checkbox"/> <input type="checkbox"/> <input type="checkbox"/></p> <p>1106 boom speed <input type="checkbox"/> <input type="checkbox"/> <input type="checkbox"/> <input type="checkbox"/> <input type="checkbox"/></p> <p>1107 pressure settings <input type="checkbox"/> <input type="checkbox"/> <input type="checkbox"/> <input type="checkbox"/> <input type="checkbox"/></p> <p>1108 hydraulic lines <input type="checkbox"/> <input type="checkbox"/> <input type="checkbox"/> <input type="checkbox"/> <input type="checkbox"/></p> <p>1109 load holding valve (piston side) <input type="checkbox"/> <input type="checkbox"/> <input type="checkbox"/> <input type="checkbox"/> <input type="checkbox"/></p> <p>1110 load holding valve (rod side) <input type="checkbox"/> <input type="checkbox"/> <input type="checkbox"/> <input type="checkbox"/> <input type="checkbox"/></p> <p>1200 joint "D"</p> <p>1201 boom <input type="checkbox"/> <input type="checkbox"/> <input type="checkbox"/> <input type="checkbox"/> <input type="checkbox"/></p> <p>1202 link lever <input type="checkbox"/> <input type="checkbox"/> <input type="checkbox"/> <input type="checkbox"/> <input type="checkbox"/></p> <p>1203 forcing rod <input type="checkbox"/> <input type="checkbox"/> <input type="checkbox"/> <input type="checkbox"/> <input type="checkbox"/></p> <p>1204 pin <input type="checkbox"/> <input type="checkbox"/> <input type="checkbox"/> <input type="checkbox"/> <input type="checkbox"/></p> <p>1205 cylinder <input type="checkbox"/> <input type="checkbox"/> <input type="checkbox"/> <input type="checkbox"/> <input type="checkbox"/></p> <p>1206 boom speed <input type="checkbox"/> <input type="checkbox"/> <input type="checkbox"/> <input type="checkbox"/> <input type="checkbox"/></p> <p>1207 pressure settings <input type="checkbox"/> <input type="checkbox"/> <input type="checkbox"/> <input type="checkbox"/> <input type="checkbox"/></p> <p>1208 hydraulic lines <input type="checkbox"/> <input type="checkbox"/> <input type="checkbox"/> <input type="checkbox"/> <input type="checkbox"/></p> <p>1209 load holding valve (piston side) <input type="checkbox"/> <input type="checkbox"/> <input type="checkbox"/> <input type="checkbox"/> <input type="checkbox"/></p> <p>1210 load holding valve (rod side) <input type="checkbox"/> <input type="checkbox"/> <input type="checkbox"/> <input type="checkbox"/> <input type="checkbox"/></p>	<p>1300 joint „E“</p> <p>1301 boom <input type="checkbox"/> <input type="checkbox"/> <input type="checkbox"/> <input type="checkbox"/> <input type="checkbox"/></p> <p>1302 link lever <input type="checkbox"/> <input type="checkbox"/> <input type="checkbox"/> <input type="checkbox"/> <input type="checkbox"/></p> <p>1303 forcing rod <input type="checkbox"/> <input type="checkbox"/> <input type="checkbox"/> <input type="checkbox"/> <input type="checkbox"/></p> <p>1304 pin <input type="checkbox"/> <input type="checkbox"/> <input type="checkbox"/> <input type="checkbox"/> <input type="checkbox"/></p> <p>1305 cylinder <input type="checkbox"/> <input type="checkbox"/> <input type="checkbox"/> <input type="checkbox"/> <input type="checkbox"/></p> <p>1306 boom speed <input type="checkbox"/> <input type="checkbox"/> <input type="checkbox"/> <input type="checkbox"/> <input type="checkbox"/></p> <p>1307 pressure settings <input type="checkbox"/> <input type="checkbox"/> <input type="checkbox"/> <input type="checkbox"/> <input type="checkbox"/></p> <p>1308 hydraulic lines <input type="checkbox"/> <input type="checkbox"/> <input type="checkbox"/> <input type="checkbox"/> <input type="checkbox"/></p> <p>1309 load holding valve (piston side) <input type="checkbox"/> <input type="checkbox"/> <input type="checkbox"/> <input type="checkbox"/> <input type="checkbox"/></p> <p>1310 load holding valve (rod side) <input type="checkbox"/> <input type="checkbox"/> <input type="checkbox"/> <input type="checkbox"/> <input type="checkbox"/></p> <p>1400 concrete delivery line</p> <p>1401 assembly of delivery line DN <input type="checkbox"/> <input type="checkbox"/> <input type="checkbox"/> <input type="checkbox"/> <input type="checkbox"/></p> <p>1402 end hose DN+length <input type="checkbox"/> <input type="checkbox"/> <input type="checkbox"/> <input type="checkbox"/> <input type="checkbox"/></p> <p>1403 delivery line DN <input type="checkbox"/> <input type="checkbox"/> <input type="checkbox"/> <input type="checkbox"/> <input type="checkbox"/></p> <p>1404 rotating joints of - delivery line <input type="checkbox"/> <input type="checkbox"/> <input type="checkbox"/> <input type="checkbox"/> <input type="checkbox"/></p> <p>1405 locking pin of the coupling <input type="checkbox"/> <input type="checkbox"/> <input type="checkbox"/> <input type="checkbox"/> <input type="checkbox"/></p> <p>Notes:</p> <hr/> <hr/> <hr/>
---	--

Inspection report for concrete booms

Page 5-5

Inspection report Nr: _____ Boom type: _____ Machine-Nr: _____

Error code:

- | | | | |
|------------------|---------------------|-------------------|--------------------------|
| 00 no objections | 08 corrosion | 16 porous | 24 deformation |
| 01 cracks | 09 lacquer failures | 17 burned through | 25 bear movement |
| 02 broken | 10 fraying | 18 not fixed | 26 lubrication |
| 03 leaky | 11 scratched | 19 clamp | 27 readability |
| 04 no function | 12 bendet | 20 sawing | 28 missing components |
| 05 low lifetime | 13 noises | 21 contaminated | 29 hydraulical |
| 06 worn out | 14 vibration | 22 bad contact | 30 electrical |
| 07 dirt | 15 miscellaneous | 23 temperature | 31 reinspection required |

1406 end hose safety device

1407 reducer

1408 gate elbow, elbow 6"

1500 hydraulic system and hydraulic valves

1501 Pressure relief valve

1502 pressure settings

1503 hydraulic lines

1504 hand operating- (function)

1505 boom control valve

1506 hydraulic pump

1600 electric equipment

1601 remote control (functions)

1602 emergency stop (function)

1603 switch for outrigger function

1604 switch for boom function

1605 wiring harness

1606 central lubrication

1700 sticker sets

1701 safety hints

1702 description

1703 operating

1704 short operating instruction

1705 sticker „don't use the boom as crane“

1706 sticker „guideline operating with boom and concrete pump“

1707 name plate

1708 sticker „danger high voltage“

Competent inspector:

Date: _____

Name: _____

Signature: _____
(stamp)

Customer:

Signature: _____
(stamp)

Inspection report for concrete pump

Page 1-3

Inspection report Nr:	Machine-Nr:	Hours of operation:
		Concrete output m ³ :
Company:	Post code:	City:

NL WV

Proof – Result of the tests

without defects	defects	reinspection required	shut down
<input type="checkbox"/>	<input type="checkbox"/>	<input type="checkbox"/>	<input type="checkbox"/>

Reinspection until date:

Error code:

- | | | | |
|------------------|---------------------|-------------------|--------------------------|
| 00 no objections | 08 corrosion | 16 porous | 24 deformation |
| 01 cracks | 09 lacquer failures | 17 burned through | 25 bear movement |
| 02 broken | 10 fraying | 18 not fixed | 26 lubrication |
| 03 leaky | 11 scratched | 19 clomp | 27 readability |
| 04 no fuction | 12 bendet | 20 sawing | 28 missing components |
| 05 low livetime | 13 noises | 21 contaminated | 29 hydraulical |
| 06 worn out | 14 vibration | 22 bad contact | 30 electrical |
| 07 dirt | 15 miscellaneous | 23 temperature | 31 reinspection required |

2000 documents

2001 operating manual

2002 spare parts list

2100 drive assembly

2101 coupling and flange

2200 gear box

2300 hydraulic pump
(main)

2400 oil-tank

2500 drive shaft

2700 hydraulic control system

2701 pressure relief valve

2702 pressure setting

2703 hydraulic line

2704 mechanical operation
by hand

2800 oil-cooler

2900 accumulator

2901 proofs of the required
tests according to
accumulator regulation

2902 pressure gauge

Notes:

Inspection report for concrete pump

Inspection report Nr: _____ Machine-Nr: _____

Error code:

00 no objections	08 corrosion	16 porous	24 deformation
01 cracks	09 lacquer failures	17 burned through	25 bear movement
02 broken	10 fraying	18 not fixed	26 lubrication
03 leaky	11 scratched	19 clomp	27 readability
04 no function	12 bendet	20 sawing	28 missing components
05 low lifetime	13 noises	21 contamitated	29 hydraulical
06 worn out	14 vibration	22 bad contact	30 electrical
07 dirt	15 miscellaneous	23 temperature	31 reinspection required

- 3000 central lubrication
- 3100 hydraulic motor
- 3200 hydraulic lines
- 3300 air compressor
- 3400 control panel
- 3500 concrete pump
- 3700 S-valve
- 3800 hopper
- 4100 sub frame
- 4200 water tank
- 4300 axle
- 4400 water pump
- 4500 vibrator

4600 safety guards, equipment

- 4601 stair
- 4602 safety for stair
- 4603 handrail
- 4604 hopper grid (fixing device)
- 4606 distance of grid rods
- 4607 distance from grid to agitator
- 4609 agitator have to stop if grid is open
- 4610 accumulator have to dump if grid is open
- 4612 cleaning flap hopper
- 4613 safety grid into water box

Notes:

Inspection report for concrete pump

Inspection report Nr: _____ Machine-Nr: _____

Error code:

- | | | | |
|------------------|---------------------|-------------------|--------------------------|
| 00 no objections | 08 corrosion | 16 porous | 24 deformation |
| 01 cracks | 09 lacquer failures | 17 burned through | 25 bear movement |
| 02 broken | 10 fraying | 18 not fixed | 26 lubrication |
| 03 leaky | 11 scratched | 19 clemp | 27 readability |
| 04 no function | 12 bendet | 20 sawing | 28 missing components |
| 05 low lifetime | 13 noises | 21 contamitated | 29 hydraulical |
| 06 worn out | 14 vibration | 22 bad contact | 30 electrical |
| 07 dirt | 15 miscellaneous | 23 temperature | 31 reinspection required |

<p>4614 cover for rotating wave <input type="checkbox"/> <input type="checkbox"/> <input type="checkbox"/> <input type="checkbox"/> <input type="checkbox"/></p> <p>4616 cover for chains <input type="checkbox"/> <input type="checkbox"/> <input type="checkbox"/> <input type="checkbox"/> <input type="checkbox"/></p> <p>4617 cover for shift cylinder <input type="checkbox"/> <input type="checkbox"/> <input type="checkbox"/> <input type="checkbox"/> <input type="checkbox"/></p> <p>4618 cover for moving parts <input type="checkbox"/> <input type="checkbox"/> <input type="checkbox"/> <input type="checkbox"/> <input type="checkbox"/></p> <p>4619 cover for the exhaust pipe <input type="checkbox"/> <input type="checkbox"/> <input type="checkbox"/> <input type="checkbox"/> <input type="checkbox"/></p> <p>4700 electrical system</p> <p>4701 function of actuator component <input type="checkbox"/> <input type="checkbox"/> <input type="checkbox"/> <input type="checkbox"/> <input type="checkbox"/></p> <p>4702 emergency stop function <input type="checkbox"/> <input type="checkbox"/> <input type="checkbox"/> <input type="checkbox"/> <input type="checkbox"/></p> <p>4703 ground connections <input type="checkbox"/> <input type="checkbox"/> <input type="checkbox"/> <input type="checkbox"/> <input type="checkbox"/></p> <p>4704 cables and wiring harness <input type="checkbox"/> <input type="checkbox"/> <input type="checkbox"/> <input type="checkbox"/> <input type="checkbox"/></p> <p>4705 temperature switch <input type="checkbox"/> <input type="checkbox"/> <input type="checkbox"/> <input type="checkbox"/> <input type="checkbox"/></p> <p>4800 outrigger - system</p> <p>4801 transportation lock <input type="checkbox"/> <input type="checkbox"/> <input type="checkbox"/> <input type="checkbox"/> <input type="checkbox"/></p> <p>4802 locking device <input type="checkbox"/> <input type="checkbox"/> <input type="checkbox"/> <input type="checkbox"/> <input type="checkbox"/></p> <p>4803 backing plate <input type="checkbox"/> <input type="checkbox"/> <input type="checkbox"/> <input type="checkbox"/> <input type="checkbox"/></p>	<p>4804 jack cylinder connections <input type="checkbox"/> <input type="checkbox"/> <input type="checkbox"/> <input type="checkbox"/> <input type="checkbox"/></p> <p>4805 pressure adjustment of jack cylinder <input type="checkbox"/> <input type="checkbox"/> <input type="checkbox"/> <input type="checkbox"/> <input type="checkbox"/></p> <p>4900 miscellaneous</p> <p>4901 additional assembled part from operator <input type="checkbox"/> <input type="checkbox"/> <input type="checkbox"/> <input type="checkbox"/> <input type="checkbox"/></p> <p>4902 changes through operator <input type="checkbox"/> <input type="checkbox"/> <input type="checkbox"/> <input type="checkbox"/> <input type="checkbox"/></p> <p>Competent inspector:</p> <p>Date:</p> <p>Name:</p> <p>Signature: (stamp)</p> <p>Customer:</p> <p>Signature: (stamp)</p> <p style="text-align: center;">This test report is filed into the test book</p>
---	---

Inspection report for concrete booms

Inspection report -Nr:	Machine-Nr	Hours of operation:
Company:	Post code:	Concrete output m ³ :
Boom Type:	Boom Nr.	City:
		NL WV

Proof – Result of the Tests

without defects <input type="checkbox"/>	defects <input type="checkbox"/>	reinspection required <input type="checkbox"/>	shut down <input type="checkbox"/>
---	-------------------------------------	---	---------------------------------------

Reinspection until date:.....

Error code:

- | | | | |
|------------------|---------------------|-------------------|--------------------------|
| 00 no objections | 08 corrosion | 16 porous | 24 deformation |
| 01 cracks | 09 lacquer failures | 17 burned through | 25 bear movement |
| 02 broken | 10 fraying | 18 not fixed | 26 lubrication |
| 03 leaky | 11 scratched | 19 clomp | 27 readability |
| 04 no function | 12 bendet | 20 sawing | 28 missing components |
| 05 low lifetime | 13 noises | 21 contaminated | 29 hydraulical |
| 06 worn out | 14 vibration | 22 bad contact | 30 electrical |
| 07 dirt | 15 miscellaneous | 23 temperature | 31 reinspection required |

<p>100 documents</p> <p>101 instruction manual <input type="checkbox"/> <input type="checkbox"/> <input type="checkbox"/> <input type="checkbox"/> <input type="checkbox"/></p> <p>102 spare parts list <input type="checkbox"/> <input type="checkbox"/> <input type="checkbox"/> <input type="checkbox"/> <input type="checkbox"/></p> <p>200 sub frame</p> <p>201 frame connection cpl. <input type="checkbox"/> <input type="checkbox"/> <input type="checkbox"/> <input type="checkbox"/> <input type="checkbox"/></p> <p>300 outrigger front R+L</p> <p>301 transportation safety device <input type="checkbox"/> <input type="checkbox"/> <input type="checkbox"/> <input type="checkbox"/> <input type="checkbox"/></p> <p>302 outrigger <input type="checkbox"/> <input type="checkbox"/> <input type="checkbox"/> <input type="checkbox"/> <input type="checkbox"/></p> <p>303 extension box <input type="checkbox"/> <input type="checkbox"/> <input type="checkbox"/> <input type="checkbox"/> <input type="checkbox"/></p> <p>304 locking device <input type="checkbox"/> <input type="checkbox"/> <input type="checkbox"/> <input type="checkbox"/> <input type="checkbox"/></p> <p>305 slewing bearing <input type="checkbox"/> <input type="checkbox"/> <input type="checkbox"/> <input type="checkbox"/> <input type="checkbox"/></p> <p>306 turn locking device <input type="checkbox"/> <input type="checkbox"/> <input type="checkbox"/> <input type="checkbox"/> <input type="checkbox"/></p> <p>307 support safeguard <input type="checkbox"/> <input type="checkbox"/> <input type="checkbox"/> <input type="checkbox"/> <input type="checkbox"/></p> <p>308 support plate <input type="checkbox"/> <input type="checkbox"/> <input type="checkbox"/> <input type="checkbox"/> <input type="checkbox"/></p> <p>309 fixing of jack cylinder <input type="checkbox"/> <input type="checkbox"/> <input type="checkbox"/> <input type="checkbox"/> <input type="checkbox"/></p> <p>310 jack cylinder <input type="checkbox"/> <input type="checkbox"/> <input type="checkbox"/> <input type="checkbox"/> <input type="checkbox"/></p>	<p>311 swing cylinder <input type="checkbox"/> <input type="checkbox"/> <input type="checkbox"/> <input type="checkbox"/> <input type="checkbox"/></p> <p>312 telescopic-cylinder <input type="checkbox"/> <input type="checkbox"/> <input type="checkbox"/> <input type="checkbox"/> <input type="checkbox"/></p> <p>313 pressure adjustment <input type="checkbox"/> <input type="checkbox"/> <input type="checkbox"/> <input type="checkbox"/> <input type="checkbox"/></p> <p>400 outrigger rear L+R</p> <p>401 transportation safety device <input type="checkbox"/> <input type="checkbox"/> <input type="checkbox"/> <input type="checkbox"/> <input type="checkbox"/></p> <p>402 outrigger <input type="checkbox"/> <input type="checkbox"/> <input type="checkbox"/> <input type="checkbox"/> <input type="checkbox"/></p> <p>403 extension box <input type="checkbox"/> <input type="checkbox"/> <input type="checkbox"/> <input type="checkbox"/> <input type="checkbox"/></p> <p>405 locking device <input type="checkbox"/> <input type="checkbox"/> <input type="checkbox"/> <input type="checkbox"/> <input type="checkbox"/></p> <p>Notes:</p> <hr/> <hr/> <hr/> <hr/> <hr/>
---	--

Inspection report for concrete booms

Inspection report Nr: _____ Boom type: _____ Machine-Nr: _____

Error code:

- | | | | |
|------------------|---------------------|-------------------|--------------------------|
| 00 no objections | 08 corrosion | 16 porous | 24 deformation |
| 01 cracks | 09 lacquer failures | 17 burned through | 25 bear movement |
| 02 broken | 10 fraying | 18 not fixed | 26 lubrication |
| 03 leaky | 11 scratched | 19 clomp | 27 readability |
| 04 no function | 12 bendet | 20 sawing | 28 missing components |
| 05 low lifetime | 13 noises | 21 contaminated | 29 hydraulic |
| 06 worn out | 14 vibration | 22 bad contact | 30 electrical |
| 07 dirt | 15 miscellaneous | 23 temperature | 31 reinspection required |

<p>406 slewing bearing <input type="checkbox"/> <input type="checkbox"/> <input type="checkbox"/> <input type="checkbox"/> <input type="checkbox"/></p> <p>407 turn locking device <input type="checkbox"/> <input type="checkbox"/> <input type="checkbox"/> <input type="checkbox"/> <input type="checkbox"/></p> <p>408 support safeguard <input type="checkbox"/> <input type="checkbox"/> <input type="checkbox"/> <input type="checkbox"/> <input type="checkbox"/></p> <p>409 support plate <input type="checkbox"/> <input type="checkbox"/> <input type="checkbox"/> <input type="checkbox"/> <input type="checkbox"/></p> <p>410 fixing of jack cylinder <input type="checkbox"/> <input type="checkbox"/> <input type="checkbox"/> <input type="checkbox"/> <input type="checkbox"/></p> <p>411 jack cylinder <input type="checkbox"/> <input type="checkbox"/> <input type="checkbox"/> <input type="checkbox"/> <input type="checkbox"/></p> <p>412 swing cylinder <input type="checkbox"/> <input type="checkbox"/> <input type="checkbox"/> <input type="checkbox"/> <input type="checkbox"/></p> <p>413 telescopic cylinder <input type="checkbox"/> <input type="checkbox"/> <input type="checkbox"/> <input type="checkbox"/> <input type="checkbox"/></p> <p>500 pedestal</p> <p>501 pedestal mounting <input type="checkbox"/> <input type="checkbox"/> <input type="checkbox"/> <input type="checkbox"/> <input type="checkbox"/></p> <p>502 sub frame <input type="checkbox"/> <input type="checkbox"/> <input type="checkbox"/> <input type="checkbox"/> <input type="checkbox"/></p> <p>503 truck frame <input type="checkbox"/> <input type="checkbox"/> <input type="checkbox"/> <input type="checkbox"/> <input type="checkbox"/></p> <p>504 pedestal (structure) <input type="checkbox"/> <input type="checkbox"/> <input type="checkbox"/> <input type="checkbox"/> <input type="checkbox"/></p> <p>505 boom valve without leaking <input type="checkbox"/> <input type="checkbox"/> <input type="checkbox"/> <input type="checkbox"/> <input type="checkbox"/></p> <p>506 boom rest <input type="checkbox"/> <input type="checkbox"/> <input type="checkbox"/> <input type="checkbox"/> <input type="checkbox"/></p> <p>507 transportation safety device <input type="checkbox"/> <input type="checkbox"/> <input type="checkbox"/> <input type="checkbox"/> <input type="checkbox"/></p> <p>508 hydraulic line <input type="checkbox"/> <input type="checkbox"/> <input type="checkbox"/> <input type="checkbox"/> <input type="checkbox"/></p> <p>600 slewing head with ball pivot</p> <p>601 slewing head <input type="checkbox"/> <input type="checkbox"/> <input type="checkbox"/> <input type="checkbox"/> <input type="checkbox"/></p> <p>602 ball pivot ring <input type="checkbox"/> <input type="checkbox"/> <input type="checkbox"/> <input type="checkbox"/> <input type="checkbox"/></p> <p>603 mounting ball pivot ring <input type="checkbox"/> <input type="checkbox"/> <input type="checkbox"/> <input type="checkbox"/> <input type="checkbox"/></p> <p>604 drive pinion <input type="checkbox"/> <input type="checkbox"/> <input type="checkbox"/> <input type="checkbox"/> <input type="checkbox"/></p>	<p>605 slewing drive mounting <input type="checkbox"/> <input type="checkbox"/> <input type="checkbox"/> <input type="checkbox"/> <input type="checkbox"/></p> <p>606 slewing stop device <input type="checkbox"/> <input type="checkbox"/> <input type="checkbox"/> <input type="checkbox"/> <input type="checkbox"/></p> <p>607 slewing drive (tooth backlash) <input type="checkbox"/> <input type="checkbox"/> <input type="checkbox"/> <input type="checkbox"/> <input type="checkbox"/></p> <p>608 slewing drive <input type="checkbox"/> <input type="checkbox"/> <input type="checkbox"/> <input type="checkbox"/> <input type="checkbox"/></p> <p>609 brake function <input type="checkbox"/> <input type="checkbox"/> <input type="checkbox"/> <input type="checkbox"/> <input type="checkbox"/></p> <p>610 speed <input type="checkbox"/> <input type="checkbox"/> <input type="checkbox"/> <input type="checkbox"/> <input type="checkbox"/></p> <p>611 pressure setting <input type="checkbox"/> <input type="checkbox"/> <input type="checkbox"/> <input type="checkbox"/> <input type="checkbox"/></p> <p>612 hydraulic lines <input type="checkbox"/> <input type="checkbox"/> <input type="checkbox"/> <input type="checkbox"/> <input type="checkbox"/></p> <p>700 slewing head with slewing column</p> <p>701 slewing head <input type="checkbox"/> <input type="checkbox"/> <input type="checkbox"/> <input type="checkbox"/> <input type="checkbox"/></p> <p>702 slewing column bearing <input type="checkbox"/> <input type="checkbox"/> <input type="checkbox"/> <input type="checkbox"/> <input type="checkbox"/></p> <p>703 slewing drive (tooth backlash) <input type="checkbox"/> <input type="checkbox"/> <input type="checkbox"/> <input type="checkbox"/> <input type="checkbox"/></p> <p>704 speed <input type="checkbox"/> <input type="checkbox"/> <input type="checkbox"/> <input type="checkbox"/> <input type="checkbox"/></p> <p>705 pressure settings <input type="checkbox"/> <input type="checkbox"/> <input type="checkbox"/> <input type="checkbox"/> <input type="checkbox"/></p> <p>706 hydraulic lines <input type="checkbox"/> <input type="checkbox"/> <input type="checkbox"/> <input type="checkbox"/> <input type="checkbox"/></p> <p>707 swivel cylinder <input type="checkbox"/> <input type="checkbox"/> <input type="checkbox"/> <input type="checkbox"/> <input type="checkbox"/></p> <p>Notes:</p> <hr/> <hr/> <hr/> <hr/>
---	---

Inspection report for concrete booms

Inspection report Nr:	Boom type:	Machine-Nr:																																
<p>Error code:</p> <table style="width: 100%; border: none;"> <tr> <td style="width: 25%;">00 no objections</td> <td style="width: 25%;">08 corrosion</td> <td style="width: 25%;">16 porous</td> <td style="width: 25%;">24 deformation</td> </tr> <tr> <td>01 cracks</td> <td>09 lacquer failures</td> <td>17 burned through</td> <td>25 bear movement</td> </tr> <tr> <td>02 broken</td> <td>10 fraying</td> <td>18 not fixed</td> <td>26 lubrication</td> </tr> <tr> <td>03 leaky</td> <td>11 scratched</td> <td>19 clomp</td> <td>27 readability</td> </tr> <tr> <td>04 no function</td> <td>12 bendet</td> <td>20 sawing</td> <td>28 missing components</td> </tr> <tr> <td>05 low lifetime</td> <td>13 noises</td> <td>21 contaminated</td> <td>29 hydraulical</td> </tr> <tr> <td>06 worn out</td> <td>14 vibration</td> <td>22 bad contact</td> <td>30 electrical</td> </tr> <tr> <td>07 dirt</td> <td>15 miscellaneous</td> <td>23 temperature</td> <td>31 reinspection required</td> </tr> </table>			00 no objections	08 corrosion	16 porous	24 deformation	01 cracks	09 lacquer failures	17 burned through	25 bear movement	02 broken	10 fraying	18 not fixed	26 lubrication	03 leaky	11 scratched	19 clomp	27 readability	04 no function	12 bendet	20 sawing	28 missing components	05 low lifetime	13 noises	21 contaminated	29 hydraulical	06 worn out	14 vibration	22 bad contact	30 electrical	07 dirt	15 miscellaneous	23 temperature	31 reinspection required
00 no objections	08 corrosion	16 porous	24 deformation																															
01 cracks	09 lacquer failures	17 burned through	25 bear movement																															
02 broken	10 fraying	18 not fixed	26 lubrication																															
03 leaky	11 scratched	19 clomp	27 readability																															
04 no function	12 bendet	20 sawing	28 missing components																															
05 low lifetime	13 noises	21 contaminated	29 hydraulical																															
06 worn out	14 vibration	22 bad contact	30 electrical																															
07 dirt	15 miscellaneous	23 temperature	31 reinspection required																															

<p>800 boom</p> <p>801 „Arm 1“ <input type="checkbox"/> <input type="checkbox"/> <input type="checkbox"/> <input type="checkbox"/> <input type="checkbox"/></p> <p>802 bracket conveying line <input type="checkbox"/> <input type="checkbox"/> <input type="checkbox"/> <input type="checkbox"/> <input type="checkbox"/></p> <p>803 Drop hook <input type="checkbox"/> <input type="checkbox"/> <input type="checkbox"/> <input type="checkbox"/> <input type="checkbox"/></p> <p>804 „Arm 2“ <input type="checkbox"/> <input type="checkbox"/> <input type="checkbox"/> <input type="checkbox"/> <input type="checkbox"/></p> <p>805 bracket conveying line <input type="checkbox"/> <input type="checkbox"/> <input type="checkbox"/> <input type="checkbox"/> <input type="checkbox"/></p> <p>806 Drop hook <input type="checkbox"/> <input type="checkbox"/> <input type="checkbox"/> <input type="checkbox"/> <input type="checkbox"/></p> <p>807 „Arm 3“ <input type="checkbox"/> <input type="checkbox"/> <input type="checkbox"/> <input type="checkbox"/> <input type="checkbox"/></p> <p>808 bracket conveying line <input type="checkbox"/> <input type="checkbox"/> <input type="checkbox"/> <input type="checkbox"/> <input type="checkbox"/></p> <p>809 guidance and interlock of the arm <input type="checkbox"/> <input type="checkbox"/> <input type="checkbox"/> <input type="checkbox"/> <input type="checkbox"/></p> <p>810 „Arm 4“ <input type="checkbox"/> <input type="checkbox"/> <input type="checkbox"/> <input type="checkbox"/> <input type="checkbox"/></p> <p>811 bracket conveying line <input type="checkbox"/> <input type="checkbox"/> <input type="checkbox"/> <input type="checkbox"/> <input type="checkbox"/></p> <p>812 guidance and interlock of the arm <input type="checkbox"/> <input type="checkbox"/> <input type="checkbox"/> <input type="checkbox"/> <input type="checkbox"/></p> <p>813 „Arm 5“ <input type="checkbox"/> <input type="checkbox"/> <input type="checkbox"/> <input type="checkbox"/> <input type="checkbox"/></p> <p>814 bracket conveying line <input type="checkbox"/> <input type="checkbox"/> <input type="checkbox"/> <input type="checkbox"/> <input type="checkbox"/></p> <p>815 guidance and interlock of the arm <input type="checkbox"/> <input type="checkbox"/> <input type="checkbox"/> <input type="checkbox"/> <input type="checkbox"/></p> <p>900 joint „A“</p> <p>901 boom <input type="checkbox"/> <input type="checkbox"/> <input type="checkbox"/> <input type="checkbox"/> <input type="checkbox"/></p> <p>902 link lever <input type="checkbox"/> <input type="checkbox"/> <input type="checkbox"/> <input type="checkbox"/> <input type="checkbox"/></p> <p>903 forcing rod <input type="checkbox"/> <input type="checkbox"/> <input type="checkbox"/> <input type="checkbox"/> <input type="checkbox"/></p> <p>904 pin <input type="checkbox"/> <input type="checkbox"/> <input type="checkbox"/> <input type="checkbox"/> <input type="checkbox"/></p> <p>905 cylinder <input type="checkbox"/> <input type="checkbox"/> <input type="checkbox"/> <input type="checkbox"/> <input type="checkbox"/></p>	<p>906 boom speed <input type="checkbox"/> <input type="checkbox"/> <input type="checkbox"/> <input type="checkbox"/> <input type="checkbox"/></p> <p>907 pressure settings <input type="checkbox"/> <input type="checkbox"/> <input type="checkbox"/> <input type="checkbox"/> <input type="checkbox"/></p> <p>908 hydraulic lines <input type="checkbox"/> <input type="checkbox"/> <input type="checkbox"/> <input type="checkbox"/> <input type="checkbox"/></p> <p>909 load holding valve (piston side) <input type="checkbox"/> <input type="checkbox"/> <input type="checkbox"/> <input type="checkbox"/> <input type="checkbox"/></p> <p>910 load holding valve (rod side) <input type="checkbox"/> <input type="checkbox"/> <input type="checkbox"/> <input type="checkbox"/> <input type="checkbox"/></p> <p>1000 joint „B“</p> <p>1001 boom <input type="checkbox"/> <input type="checkbox"/> <input type="checkbox"/> <input type="checkbox"/> <input type="checkbox"/></p> <p>1002 link lever <input type="checkbox"/> <input type="checkbox"/> <input type="checkbox"/> <input type="checkbox"/> <input type="checkbox"/></p> <p>1003 forcing rod <input type="checkbox"/> <input type="checkbox"/> <input type="checkbox"/> <input type="checkbox"/> <input type="checkbox"/></p> <p>1004 pin <input type="checkbox"/> <input type="checkbox"/> <input type="checkbox"/> <input type="checkbox"/> <input type="checkbox"/></p> <p>1005 cylinder <input type="checkbox"/> <input type="checkbox"/> <input type="checkbox"/> <input type="checkbox"/> <input type="checkbox"/></p> <p>1006 boom speed <input type="checkbox"/> <input type="checkbox"/> <input type="checkbox"/> <input type="checkbox"/> <input type="checkbox"/></p> <p>1007 pressure settings <input type="checkbox"/> <input type="checkbox"/> <input type="checkbox"/> <input type="checkbox"/> <input type="checkbox"/></p> <p>1008 hydraulic lines <input type="checkbox"/> <input type="checkbox"/> <input type="checkbox"/> <input type="checkbox"/> <input type="checkbox"/></p> <p>1009 load holding valve (piston side) <input type="checkbox"/> <input type="checkbox"/> <input type="checkbox"/> <input type="checkbox"/> <input type="checkbox"/></p> <p>1010 load holding valve (rod side) <input type="checkbox"/> <input type="checkbox"/> <input type="checkbox"/> <input type="checkbox"/> <input type="checkbox"/></p> <p>Notes:</p> <hr/> <hr/> <hr/> <hr/>
--	---

Inspection report for concrete booms

Inspection report Nr: _____ Boom type: _____ Machine-Nr: _____

Error code:			
00 no objections	08 corrosion	16 porous	24 deformation
01 cracks	09 lacquer failures	17 burned through	25 bear movement
02 broken	10 fraying	18 not fixed	26 lubrication
03 leaky	11 scratched	19 clomp	27 readability
04 no function	12 bendet	20 sawing	28 missing components
05 low lifetime	13 noises	21 contaminated	29 hydraulic
06 worn out	14 vibration	22 bad contact	30 electrical
07 dirt	15 miscellaneous	23 temperature	31 reinspection required

<p>1100 joint "C"</p> <p>1101 boom <input type="checkbox"/> <input type="checkbox"/> <input type="checkbox"/> <input type="checkbox"/> <input type="checkbox"/></p> <p>1102 link lever <input type="checkbox"/> <input type="checkbox"/> <input type="checkbox"/> <input type="checkbox"/> <input type="checkbox"/></p> <p>1103 forcing rod <input type="checkbox"/> <input type="checkbox"/> <input type="checkbox"/> <input type="checkbox"/> <input type="checkbox"/></p> <p>1104 pin <input type="checkbox"/> <input type="checkbox"/> <input type="checkbox"/> <input type="checkbox"/> <input type="checkbox"/></p> <p>1105 cylinder <input type="checkbox"/> <input type="checkbox"/> <input type="checkbox"/> <input type="checkbox"/> <input type="checkbox"/></p> <p>1106 boom speed <input type="checkbox"/> <input type="checkbox"/> <input type="checkbox"/> <input type="checkbox"/> <input type="checkbox"/></p> <p>1107 pressure settings <input type="checkbox"/> <input type="checkbox"/> <input type="checkbox"/> <input type="checkbox"/> <input type="checkbox"/></p> <p>1108 hydraulic lines <input type="checkbox"/> <input type="checkbox"/> <input type="checkbox"/> <input type="checkbox"/> <input type="checkbox"/></p> <p>1109 load holding valve (piston side) <input type="checkbox"/> <input type="checkbox"/> <input type="checkbox"/> <input type="checkbox"/> <input type="checkbox"/></p> <p>1110 load holding valve (rod side) <input type="checkbox"/> <input type="checkbox"/> <input type="checkbox"/> <input type="checkbox"/> <input type="checkbox"/></p> <p>1200 joint "D"</p> <p>1201 boom <input type="checkbox"/> <input type="checkbox"/> <input type="checkbox"/> <input type="checkbox"/> <input type="checkbox"/></p> <p>1202 link lever <input type="checkbox"/> <input type="checkbox"/> <input type="checkbox"/> <input type="checkbox"/> <input type="checkbox"/></p> <p>1203 forcing rod <input type="checkbox"/> <input type="checkbox"/> <input type="checkbox"/> <input type="checkbox"/> <input type="checkbox"/></p> <p>1204 pin <input type="checkbox"/> <input type="checkbox"/> <input type="checkbox"/> <input type="checkbox"/> <input type="checkbox"/></p> <p>1205 cylinder <input type="checkbox"/> <input type="checkbox"/> <input type="checkbox"/> <input type="checkbox"/> <input type="checkbox"/></p> <p>1206 boom speed <input type="checkbox"/> <input type="checkbox"/> <input type="checkbox"/> <input type="checkbox"/> <input type="checkbox"/></p> <p>1207 pressure settings <input type="checkbox"/> <input type="checkbox"/> <input type="checkbox"/> <input type="checkbox"/> <input type="checkbox"/></p> <p>1208 hydraulic lines <input type="checkbox"/> <input type="checkbox"/> <input type="checkbox"/> <input type="checkbox"/> <input type="checkbox"/></p> <p>1209 load holding valve (piston side) <input type="checkbox"/> <input type="checkbox"/> <input type="checkbox"/> <input type="checkbox"/> <input type="checkbox"/></p> <p>1210 load holding valve (rod side) <input type="checkbox"/> <input type="checkbox"/> <input type="checkbox"/> <input type="checkbox"/> <input type="checkbox"/></p>	<p>1300 joint „E“</p> <p>1301 boom <input type="checkbox"/> <input type="checkbox"/> <input type="checkbox"/> <input type="checkbox"/> <input type="checkbox"/></p> <p>1302 link lever <input type="checkbox"/> <input type="checkbox"/> <input type="checkbox"/> <input type="checkbox"/> <input type="checkbox"/></p> <p>1303 forcing rod <input type="checkbox"/> <input type="checkbox"/> <input type="checkbox"/> <input type="checkbox"/> <input type="checkbox"/></p> <p>1304 pin <input type="checkbox"/> <input type="checkbox"/> <input type="checkbox"/> <input type="checkbox"/> <input type="checkbox"/></p> <p>1305 cylinder <input type="checkbox"/> <input type="checkbox"/> <input type="checkbox"/> <input type="checkbox"/> <input type="checkbox"/></p> <p>1306 boom speed <input type="checkbox"/> <input type="checkbox"/> <input type="checkbox"/> <input type="checkbox"/> <input type="checkbox"/></p> <p>1307 pressure settings <input type="checkbox"/> <input type="checkbox"/> <input type="checkbox"/> <input type="checkbox"/> <input type="checkbox"/></p> <p>1308 hydraulic lines <input type="checkbox"/> <input type="checkbox"/> <input type="checkbox"/> <input type="checkbox"/> <input type="checkbox"/></p> <p>1309 load holding valve (piston side) <input type="checkbox"/> <input type="checkbox"/> <input type="checkbox"/> <input type="checkbox"/> <input type="checkbox"/></p> <p>1310 load holding valve (rod side) <input type="checkbox"/> <input type="checkbox"/> <input type="checkbox"/> <input type="checkbox"/> <input type="checkbox"/></p> <p>1400 concrete delivery line</p> <p>1401 assembly of delivery line DN <input type="checkbox"/> <input type="checkbox"/> <input type="checkbox"/> <input type="checkbox"/> <input type="checkbox"/></p> <p>1402 end hose DN+lenght <input type="checkbox"/> <input type="checkbox"/> <input type="checkbox"/> <input type="checkbox"/> <input type="checkbox"/></p> <p>1403 delivery line DN <input type="checkbox"/> <input type="checkbox"/> <input type="checkbox"/> <input type="checkbox"/> <input type="checkbox"/></p> <p>1404 rotating joints of - delivery line <input type="checkbox"/> <input type="checkbox"/> <input type="checkbox"/> <input type="checkbox"/> <input type="checkbox"/></p> <p>1405 locking pin of the coupling <input type="checkbox"/> <input type="checkbox"/> <input type="checkbox"/> <input type="checkbox"/> <input type="checkbox"/></p> <p>Notes:</p> <hr/> <hr/> <hr/>
---	--

Inspection report for concrete booms

Inspection report Nr: _____ Boom type: _____ Machine-Nr: _____

Error code:

- | | | | |
|------------------|---------------------|-------------------|--------------------------|
| 00 no objections | 08 corrosion | 16 porous | 24 deformation |
| 01 cracks | 09 lacquer failures | 17 burned through | 25 bear movement |
| 02 broken | 10 fraying | 18 not fixed | 26 lubrication |
| 03 leaky | 11 scratched | 19 clemp | 27 readability |
| 04 no function | 12 bendet | 20 sawing | 28 missing components |
| 05 low lifetime | 13 noises | 21 contamitated | 29 hydraulical |
| 06 worn out | 14 vibration | 22 bad contact | 30 electrical |
| 07 dirt | 15 miscellaneous | 23 temperature | 31 reinspection required |

<p>1406 end hose safety device <input type="checkbox"/> <input type="checkbox"/> <input type="checkbox"/> <input type="checkbox"/> <input type="checkbox"/></p> <p>1407 reducer <input type="checkbox"/> <input type="checkbox"/> <input type="checkbox"/> <input type="checkbox"/> <input type="checkbox"/></p> <p>1408 gate elbow, elbow 6" <input type="checkbox"/> <input type="checkbox"/> <input type="checkbox"/> <input type="checkbox"/> <input type="checkbox"/></p> <p>1500 hydraulic system and hydraulic valves</p> <p>1501 Pressure relief valve <input type="checkbox"/> <input type="checkbox"/> <input type="checkbox"/> <input type="checkbox"/> <input type="checkbox"/></p> <p>1502 pressure settings <input type="checkbox"/> <input type="checkbox"/> <input type="checkbox"/> <input type="checkbox"/> <input type="checkbox"/></p> <p>1503 hydraulic lines <input type="checkbox"/> <input type="checkbox"/> <input type="checkbox"/> <input type="checkbox"/> <input type="checkbox"/></p> <p>1504 hand operating- (function) <input type="checkbox"/> <input type="checkbox"/> <input type="checkbox"/> <input type="checkbox"/> <input type="checkbox"/></p> <p>1505 boom control valve <input type="checkbox"/> <input type="checkbox"/> <input type="checkbox"/> <input type="checkbox"/> <input type="checkbox"/></p> <p>1506 hydraulic pump <input type="checkbox"/> <input type="checkbox"/> <input type="checkbox"/> <input type="checkbox"/> <input type="checkbox"/></p> <p>1600 electric equipment</p> <p>1601 remote control (functions) <input type="checkbox"/> <input type="checkbox"/> <input type="checkbox"/> <input type="checkbox"/> <input type="checkbox"/></p> <p>1602 emergency stop (function) <input type="checkbox"/> <input type="checkbox"/> <input type="checkbox"/> <input type="checkbox"/> <input type="checkbox"/></p> <p>1603 switch for outrigger function <input type="checkbox"/> <input type="checkbox"/> <input type="checkbox"/> <input type="checkbox"/> <input type="checkbox"/></p> <p>1604 switch for boom function <input type="checkbox"/> <input type="checkbox"/> <input type="checkbox"/> <input type="checkbox"/> <input type="checkbox"/></p> <p>1605 wiring harness <input type="checkbox"/> <input type="checkbox"/> <input type="checkbox"/> <input type="checkbox"/> <input type="checkbox"/></p> <p>1606 central lubrication <input type="checkbox"/> <input type="checkbox"/> <input type="checkbox"/> <input type="checkbox"/> <input type="checkbox"/></p>	<p>1700 sticker sets</p> <p>1701 safety hints <input type="checkbox"/> <input type="checkbox"/> <input type="checkbox"/> <input type="checkbox"/> <input type="checkbox"/></p> <p>1702 description <input type="checkbox"/> <input type="checkbox"/> <input type="checkbox"/> <input type="checkbox"/> <input type="checkbox"/></p> <p>1703 operating <input type="checkbox"/> <input type="checkbox"/> <input type="checkbox"/> <input type="checkbox"/> <input type="checkbox"/></p> <p>1704 short operating instruction <input type="checkbox"/> <input type="checkbox"/> <input type="checkbox"/> <input type="checkbox"/> <input type="checkbox"/></p> <p>1705 sticker „ don't use the boom as crane“ <input type="checkbox"/> <input type="checkbox"/> <input type="checkbox"/> <input type="checkbox"/> <input type="checkbox"/></p> <p>1706 sticker „guideline operating with boom- and concrete pump“ <input type="checkbox"/> <input type="checkbox"/> <input type="checkbox"/> <input type="checkbox"/> <input type="checkbox"/></p> <p>1707 name plate <input type="checkbox"/> <input type="checkbox"/> <input type="checkbox"/> <input type="checkbox"/> <input type="checkbox"/></p> <p>1708 sticker „danger high voltage“ <input type="checkbox"/> <input type="checkbox"/> <input type="checkbox"/> <input type="checkbox"/> <input type="checkbox"/></p> <hr/> <p>Competent inspector:</p> <p>Date: _____</p> <p>Name: _____</p> <p>Signature: _____ (stamp)</p> <p>Customer:</p> <p>Signature: _____ (stamp)</p>
---	--

Inspection report for concrete pump

Inspection report Nr:	Machine-Nr:	Hours of operation:
		Concrete output m ³ :
Company:	Post code:	City:

NL	WV
----	----

Proof – Result of the tests

without defects	defects	reinspection required	shut down
<input type="checkbox"/>	<input type="checkbox"/>	<input type="checkbox"/>	<input type="checkbox"/>

Reinspection until date:

- Error code:**
- | | | | |
|------------------|---------------------|-------------------|--------------------------|
| 00 no objections | 08 corrosion | 16 porous | 24 deformation |
| 01 cracks | 09 lacquer failures | 17 burned through | 25 bear movement |
| 02 broken | 10 fraying | 18 not fixed | 26 lubrication |
| 03 leaky | 11 scratched | 19 clomp | 27 readability |
| 04 no fuction | 12 bendet | 20 sawing | 28 missing components |
| 05 low livetime | 13 noises | 21 contaminated | 29 hydraulical |
| 06 worn out | 14 vibration | 22 bad contact | 30 electrical |
| 07 dirt | 15 miscellaneous | 23 temperature | 31 reinspection required |

2000 documents

2001 operating manual

2002 spare parts list

2100 drive assembly

2101 coupling and flange

2200 gear box

2300 hydraulic pump
(main)

2400 oil-tank

2500 drive shaft

2700 hydraulic control system

2701 pressure relief valve

2702 pressure setting

2703 hydraulic line

2704 mechanical operation
by hand

2800 oil-cooler

2900 accumulator

2901 proofs of the required
tests according to
accumulator regulation

2902 pressure gauge

Notes:

Inspection report for concrete pump

Inspection report Nr: _____ Machine-Nr: _____

Error code:

- | | | | |
|------------------|---------------------|-------------------|--------------------------|
| 00 no objections | 08 corrosion | 16 porous | 24 deformation |
| 01 cracks | 09 lacquer failures | 17 burned through | 25 bear movement |
| 02 broken | 10 fraying | 18 not fixed | 26 lubrication |
| 03 leaky | 11 scratched | 19 clemp | 27 readability |
| 04 no function | 12 bendet | 20 sawing | 28 missing components |
| 05 low lifetime | 13 noises | 21 contaminated | 29 hydraulical |
| 06 worn out | 14 vibration | 22 bad contact | 30 electrical |
| 07 dirt | 15 miscellaneous | 23 temperature | 31 reinspection required |

<p>3000 central lubrication <input type="checkbox"/> <input type="checkbox"/> <input type="checkbox"/> <input type="checkbox"/> <input type="checkbox"/></p> <p>3100 hydraulic motor <input type="checkbox"/> <input type="checkbox"/> <input type="checkbox"/> <input type="checkbox"/> <input type="checkbox"/></p> <p>3200 hydraulic lines <input type="checkbox"/> <input type="checkbox"/> <input type="checkbox"/> <input type="checkbox"/> <input type="checkbox"/></p> <p>3300 air compressor <input type="checkbox"/> <input type="checkbox"/> <input type="checkbox"/> <input type="checkbox"/> <input type="checkbox"/></p> <p>3400 control panel <input type="checkbox"/> <input type="checkbox"/> <input type="checkbox"/> <input type="checkbox"/> <input type="checkbox"/></p> <p>3500 concrete pump <input type="checkbox"/> <input type="checkbox"/> <input type="checkbox"/> <input type="checkbox"/> <input type="checkbox"/></p> <p>3700 S-valve <input type="checkbox"/> <input type="checkbox"/> <input type="checkbox"/> <input type="checkbox"/> <input type="checkbox"/></p> <p>3800 hopper <input type="checkbox"/> <input type="checkbox"/> <input type="checkbox"/> <input type="checkbox"/> <input type="checkbox"/></p> <p>4100 sub frame <input type="checkbox"/> <input type="checkbox"/> <input type="checkbox"/> <input type="checkbox"/> <input type="checkbox"/></p> <p>4200 water tank <input type="checkbox"/> <input type="checkbox"/> <input type="checkbox"/> <input type="checkbox"/> <input type="checkbox"/></p> <p>4300 axle <input type="checkbox"/> <input type="checkbox"/> <input type="checkbox"/> <input type="checkbox"/> <input type="checkbox"/></p> <p>4400 water pump <input type="checkbox"/> <input type="checkbox"/> <input type="checkbox"/> <input type="checkbox"/> <input type="checkbox"/></p> <p>4500 vibrator <input type="checkbox"/> <input type="checkbox"/> <input type="checkbox"/> <input type="checkbox"/> <input type="checkbox"/></p>	<p>4600 safety guards, equipment</p> <p>4601 stair <input type="checkbox"/> <input type="checkbox"/> <input type="checkbox"/> <input type="checkbox"/> <input type="checkbox"/></p> <p>4602 safety for stair <input type="checkbox"/> <input type="checkbox"/> <input type="checkbox"/> <input type="checkbox"/> <input type="checkbox"/></p> <p>4603 handrail <input type="checkbox"/> <input type="checkbox"/> <input type="checkbox"/> <input type="checkbox"/> <input type="checkbox"/></p> <p>4604 hopper grid (fixing device) <input type="checkbox"/> <input type="checkbox"/> <input type="checkbox"/> <input type="checkbox"/> <input type="checkbox"/></p> <p>4606 distance of grid rods <input type="checkbox"/> <input type="checkbox"/> <input type="checkbox"/> <input type="checkbox"/> <input type="checkbox"/></p> <p>4607 distance from grid to agitator <input type="checkbox"/> <input type="checkbox"/> <input type="checkbox"/> <input type="checkbox"/> <input type="checkbox"/></p> <p>4609 agitator have to stop if grid is open <input type="checkbox"/> <input type="checkbox"/> <input type="checkbox"/> <input type="checkbox"/> <input type="checkbox"/></p> <p>4610 accumulator have to dump if grid is open <input type="checkbox"/> <input type="checkbox"/> <input type="checkbox"/> <input type="checkbox"/> <input type="checkbox"/></p> <p>4612 cleaning flap hopper <input type="checkbox"/> <input type="checkbox"/> <input type="checkbox"/> <input type="checkbox"/> <input type="checkbox"/></p> <p>4613 safety grid into water box <input type="checkbox"/> <input type="checkbox"/> <input type="checkbox"/> <input type="checkbox"/> <input type="checkbox"/></p>
--	---

Notes:

Inspection report for concrete pump

Inspection report Nr: _____ Machine-Nr: _____

Error code:

- | | | | |
|------------------|---------------------|-------------------|--------------------------|
| 00 no objections | 08 corrosion | 16 porous | 24 deformation |
| 01 cracks | 09 lacquer failures | 17 burned through | 25 bear movement |
| 02 broken | 10 fraying | 18 not fixed | 26 lubrication |
| 03 leaky | 11 scratched | 19 clemp | 27 readability |
| 04 no function | 12 bendet | 20 sawing | 28 missing components |
| 05 low lifetime | 13 noises | 21 contaminated | 29 hydraulical |
| 06 worn out | 14 vibration | 22 bad contact | 30 electrical |
| 07 dirt | 15 miscellaneous | 23 temperature | 31 reinspection required |

4614 cover for rotating wave

4616 cover for chains

4617 cover for shift cylinder

4618 cover for moving parts

4619 cover for the exhaust pipe

4700 electrical system

4701 function of actuator component

4702 emergency stop function

4703 ground connections

4704 cables and wiring harness

4705 temperature switch

4800 outrigger - system

4801 transportation lock

4802 locking device

4803 backing plate

4804 jack cylinder connections

4805 pressure adjustment of jack cylinder

4900 miscellaneous

4901 additional assembled part from operator

4902 changes through operator

Competent inspector:

Date:

Name:

Signature:
(stamp)

Customer:

Signature:
(stamp)

This test report is filed into the test book

Inspection report for concrete booms

Inspection report -Nr:	Machine-Nr	Hours of operation:	
		Concrete output m³:	
Company:	Post code:	City:	
Boom Type:	Boom Nr.	NL	WV

Proof – Result of the Tests

without defects	defects	reinspection required	shut down
<input type="checkbox"/>	<input type="checkbox"/>	<input type="checkbox"/>	<input type="checkbox"/>

Reinspection until date:

Error code:

- | | | | |
|------------------|---------------------|-------------------|--------------------------|
| 00 no objections | 08 corrosion | 16 porous | 24 deformation |
| 01 cracks | 09 lacquer failures | 17 burned through | 25 bear movement |
| 02 broken | 10 fraying | 18 not fixed | 26 lubrication |
| 03 leaky | 11 scratched | 19 clemp | 27 readability |
| 04 no function | 12 bendet | 20 sawing | 28 missing components |
| 05 low lifetime | 13 noises | 21 contaminated | 29 hydraulic |
| 06 worn out | 14 vibration | 22 bad contact | 30 electrical |
| 07 dirt | 15 miscellaneous | 23 temperature | 31 reinspection required |

100 documents

101 instruction manual	<input type="checkbox"/>	<input type="checkbox"/>	<input type="checkbox"/>	<input type="checkbox"/>	
102 spare parts list	<input type="checkbox"/>	<input type="checkbox"/>	<input type="checkbox"/>	<input type="checkbox"/>	<input type="checkbox"/>

200 sub frame

201 frame connection cpl.	<input type="checkbox"/>	<input type="checkbox"/>	<input type="checkbox"/>	<input type="checkbox"/>	<input type="checkbox"/>
---------------------------	--------------------------	--------------------------	--------------------------	--------------------------	--------------------------

300 outrigger front R+L

301 transportation safety device	<input type="checkbox"/>	<input type="checkbox"/>	<input type="checkbox"/>	<input type="checkbox"/>	<input type="checkbox"/>
302 outrigger	<input type="checkbox"/>	<input type="checkbox"/>	<input type="checkbox"/>	<input type="checkbox"/>	<input type="checkbox"/>
303 extension box	<input type="checkbox"/>	<input type="checkbox"/>	<input type="checkbox"/>	<input type="checkbox"/>	<input type="checkbox"/>
304 locking device	<input type="checkbox"/>	<input type="checkbox"/>	<input type="checkbox"/>	<input type="checkbox"/>	<input type="checkbox"/>
305 slewing bearing	<input type="checkbox"/>	<input type="checkbox"/>	<input type="checkbox"/>	<input type="checkbox"/>	<input type="checkbox"/>
306 turn locking device	<input type="checkbox"/>	<input type="checkbox"/>	<input type="checkbox"/>	<input type="checkbox"/>	<input type="checkbox"/>
307 support safeguard	<input type="checkbox"/>	<input type="checkbox"/>	<input type="checkbox"/>	<input type="checkbox"/>	<input type="checkbox"/>
308 support plate	<input type="checkbox"/>	<input type="checkbox"/>	<input type="checkbox"/>	<input type="checkbox"/>	<input type="checkbox"/>
309 fixing of jack cylinder	<input type="checkbox"/>	<input type="checkbox"/>	<input type="checkbox"/>	<input type="checkbox"/>	<input type="checkbox"/>
310 jack cylinder	<input type="checkbox"/>	<input type="checkbox"/>	<input type="checkbox"/>	<input type="checkbox"/>	<input type="checkbox"/>

311 swing cylinder	<input type="checkbox"/>	<input type="checkbox"/>	<input type="checkbox"/>	<input type="checkbox"/>	<input type="checkbox"/>
--------------------	--------------------------	--------------------------	--------------------------	--------------------------	--------------------------

312 telescopic-cylinder	<input type="checkbox"/>	<input type="checkbox"/>	<input type="checkbox"/>	<input type="checkbox"/>	<input type="checkbox"/>
-------------------------	--------------------------	--------------------------	--------------------------	--------------------------	--------------------------

313 pressure adjustment	<input type="checkbox"/>	<input type="checkbox"/>	<input type="checkbox"/>	<input type="checkbox"/>	<input type="checkbox"/>
-------------------------	--------------------------	--------------------------	--------------------------	--------------------------	--------------------------

400 outrigger rear L+R

401 transportation safety device	<input type="checkbox"/>	<input type="checkbox"/>	<input type="checkbox"/>	<input type="checkbox"/>	<input type="checkbox"/>
----------------------------------	--------------------------	--------------------------	--------------------------	--------------------------	--------------------------

402 outrigger	<input type="checkbox"/>	<input type="checkbox"/>	<input type="checkbox"/>	<input type="checkbox"/>	<input type="checkbox"/>
---------------	--------------------------	--------------------------	--------------------------	--------------------------	--------------------------

403 extension box	<input type="checkbox"/>	<input type="checkbox"/>	<input type="checkbox"/>	<input type="checkbox"/>	<input type="checkbox"/>
-------------------	--------------------------	--------------------------	--------------------------	--------------------------	--------------------------

405 locking device	<input type="checkbox"/>	<input type="checkbox"/>	<input type="checkbox"/>	<input type="checkbox"/>	<input type="checkbox"/>
--------------------	--------------------------	--------------------------	--------------------------	--------------------------	--------------------------

Notes:

Inspection report for concrete booms

Inspection report Nr: _____ Boom type: _____ Machine-Nr: _____

Error code:

- | | | | |
|------------------|---------------------|-------------------|--------------------------|
| 00 no objections | 08 corrosion | 16 porous | 24 deformation |
| 01 cracks | 09 lacquer failures | 17 burned through | 25 bear movement |
| 02 broken | 10 fraying | 18 not fixed | 26 lubrication |
| 03 leaky | 11 scratched | 19 clomp | 27 readability |
| 04 no function | 12 bendet | 20 sawing | 28 missing components |
| 05 low lifetime | 13 noises | 21 contaminated | 29 hydraulical |
| 06 worn out | 14 vibration | 22 bad contact | 30 electrical |
| 07 dirt | 15 miscellaneous | 23 temperature | 31 reinspection required |

<p>406 slewing bearing <input type="checkbox"/> <input type="checkbox"/> <input type="checkbox"/> <input type="checkbox"/> <input type="checkbox"/></p> <p>407 turn locking device <input type="checkbox"/> <input type="checkbox"/> <input type="checkbox"/> <input type="checkbox"/> <input type="checkbox"/></p> <p>408 support safeguard <input type="checkbox"/> <input type="checkbox"/> <input type="checkbox"/> <input type="checkbox"/> <input type="checkbox"/></p> <p>409 support plate <input type="checkbox"/> <input type="checkbox"/> <input type="checkbox"/> <input type="checkbox"/> <input type="checkbox"/></p> <p>410 fixing of jack cylinder <input type="checkbox"/> <input type="checkbox"/> <input type="checkbox"/> <input type="checkbox"/> <input type="checkbox"/></p> <p>411 jack cylinder <input type="checkbox"/> <input type="checkbox"/> <input type="checkbox"/> <input type="checkbox"/> <input type="checkbox"/></p> <p>412 swing cylinder <input type="checkbox"/> <input type="checkbox"/> <input type="checkbox"/> <input type="checkbox"/> <input type="checkbox"/></p> <p>413 telescopic cylinder <input type="checkbox"/> <input type="checkbox"/> <input type="checkbox"/> <input type="checkbox"/> <input type="checkbox"/></p> <p>500 pedestal</p> <p>501 pedestal mounting <input type="checkbox"/> <input type="checkbox"/> <input type="checkbox"/> <input type="checkbox"/> <input type="checkbox"/></p> <p>502 sub frame <input type="checkbox"/> <input type="checkbox"/> <input type="checkbox"/> <input type="checkbox"/> <input type="checkbox"/></p> <p>503 truck frame <input type="checkbox"/> <input type="checkbox"/> <input type="checkbox"/> <input type="checkbox"/> <input type="checkbox"/></p> <p>504 pedestal (structure) <input type="checkbox"/> <input type="checkbox"/> <input type="checkbox"/> <input type="checkbox"/> <input type="checkbox"/></p> <p>505 boom valve without leaking <input type="checkbox"/> <input type="checkbox"/> <input type="checkbox"/> <input type="checkbox"/> <input type="checkbox"/></p> <p>506 boom rest <input type="checkbox"/> <input type="checkbox"/> <input type="checkbox"/> <input type="checkbox"/> <input type="checkbox"/></p> <p>507 transportation safety device <input type="checkbox"/> <input type="checkbox"/> <input type="checkbox"/> <input type="checkbox"/> <input type="checkbox"/></p> <p>508 hydraulic line <input type="checkbox"/> <input type="checkbox"/> <input type="checkbox"/> <input type="checkbox"/> <input type="checkbox"/></p> <p>600 slewing head with ball pivot</p> <p>601 slewing head <input type="checkbox"/> <input type="checkbox"/> <input type="checkbox"/> <input type="checkbox"/> <input type="checkbox"/></p> <p>602 ball pivot ring <input type="checkbox"/> <input type="checkbox"/> <input type="checkbox"/> <input type="checkbox"/> <input type="checkbox"/></p> <p>603 mounting ball pivot ring <input type="checkbox"/> <input type="checkbox"/> <input type="checkbox"/> <input type="checkbox"/> <input type="checkbox"/></p> <p>604 drive pinion <input type="checkbox"/> <input type="checkbox"/> <input type="checkbox"/> <input type="checkbox"/> <input type="checkbox"/></p>	<p>605 slewing drive mounting <input type="checkbox"/> <input type="checkbox"/> <input type="checkbox"/> <input type="checkbox"/> <input type="checkbox"/></p> <p>606 slewing stop device <input type="checkbox"/> <input type="checkbox"/> <input type="checkbox"/> <input type="checkbox"/> <input type="checkbox"/></p> <p>607 slewing drive (tooth backlash) <input type="checkbox"/> <input type="checkbox"/> <input type="checkbox"/> <input type="checkbox"/> <input type="checkbox"/></p> <p>608 slewing drive <input type="checkbox"/> <input type="checkbox"/> <input type="checkbox"/> <input type="checkbox"/> <input type="checkbox"/></p> <p>609 brake function <input type="checkbox"/> <input type="checkbox"/> <input type="checkbox"/> <input type="checkbox"/> <input type="checkbox"/></p> <p>610 speed <input type="checkbox"/> <input type="checkbox"/> <input type="checkbox"/> <input type="checkbox"/> <input type="checkbox"/></p> <p>611 pressure setting <input type="checkbox"/> <input type="checkbox"/> <input type="checkbox"/> <input type="checkbox"/> <input type="checkbox"/></p> <p>612 hydraulic lines <input type="checkbox"/> <input type="checkbox"/> <input type="checkbox"/> <input type="checkbox"/> <input type="checkbox"/></p> <p>700 slewing head with slewing column</p> <p>701 slewing head <input type="checkbox"/> <input type="checkbox"/> <input type="checkbox"/> <input type="checkbox"/> <input type="checkbox"/></p> <p>702 slewing column bearing <input type="checkbox"/> <input type="checkbox"/> <input type="checkbox"/> <input type="checkbox"/> <input type="checkbox"/></p> <p>703 slewing drive (tooth backlash) <input type="checkbox"/> <input type="checkbox"/> <input type="checkbox"/> <input type="checkbox"/> <input type="checkbox"/></p> <p>704 speed <input type="checkbox"/> <input type="checkbox"/> <input type="checkbox"/> <input type="checkbox"/> <input type="checkbox"/></p> <p>705 pressure settings <input type="checkbox"/> <input type="checkbox"/> <input type="checkbox"/> <input type="checkbox"/> <input type="checkbox"/></p> <p>706 hydraulic lines <input type="checkbox"/> <input type="checkbox"/> <input type="checkbox"/> <input type="checkbox"/> <input type="checkbox"/></p> <p>707 swivel cylinder <input type="checkbox"/> <input type="checkbox"/> <input type="checkbox"/> <input type="checkbox"/> <input type="checkbox"/></p> <p>Notes:</p> <hr/> <hr/> <hr/> <hr/>
---	---

Inspection report for concrete booms

Inspection report Nr:	Boom type:	Machine-Nr:
-----------------------	------------	-------------

- Error code:**
- | | | | |
|------------------|---------------------|-------------------|--------------------------|
| 00 no objections | 08 corrosion | 16 porous | 24 deformation |
| 01 cracks | 09 lacquer failures | 17 burned through | 25 bear movement |
| 02 broken | 10 fraying | 18 not fixed | 26 lubrication |
| 03 leaky | 11 scratched | 19 clemp | 27 readability |
| 04 no function | 12 bendet | 20 sawing | 28 missing components |
| 05 low lifetime | 13 noises | 21 contaminated | 29 hydraulical |
| 06 worn out | 14 vibration | 22 bad contact | 30 electrical |
| 07 dirt | 15 miscellaneous | 23 temperature | 31 reinspection required |

<p>800 boom</p> <p>801 „Arm 1“ <input type="checkbox"/> <input type="checkbox"/> <input type="checkbox"/> <input type="checkbox"/> <input type="checkbox"/></p> <p>802 bracket conveying line <input type="checkbox"/> <input type="checkbox"/> <input type="checkbox"/> <input type="checkbox"/> <input type="checkbox"/></p> <p>803 Drop hook <input type="checkbox"/> <input type="checkbox"/> <input type="checkbox"/> <input type="checkbox"/> <input type="checkbox"/></p> <p>804 „Arm 2“ <input type="checkbox"/> <input type="checkbox"/> <input type="checkbox"/> <input type="checkbox"/> <input type="checkbox"/></p> <p>805 bracket conveying line <input type="checkbox"/> <input type="checkbox"/> <input type="checkbox"/> <input type="checkbox"/> <input type="checkbox"/></p> <p>806 Drop hook <input type="checkbox"/> <input type="checkbox"/> <input type="checkbox"/> <input type="checkbox"/> <input type="checkbox"/></p> <p>807 „Arm 3“ <input type="checkbox"/> <input type="checkbox"/> <input type="checkbox"/> <input type="checkbox"/> <input type="checkbox"/></p> <p>808 bracket conveying line <input type="checkbox"/> <input type="checkbox"/> <input type="checkbox"/> <input type="checkbox"/> <input type="checkbox"/></p> <p>809 guidance and interlock of the arm <input type="checkbox"/> <input type="checkbox"/> <input type="checkbox"/> <input type="checkbox"/> <input type="checkbox"/></p> <p>810 „Arm 4“ <input type="checkbox"/> <input type="checkbox"/> <input type="checkbox"/> <input type="checkbox"/> <input type="checkbox"/></p> <p>811 bracket conveying line <input type="checkbox"/> <input type="checkbox"/> <input type="checkbox"/> <input type="checkbox"/> <input type="checkbox"/></p> <p>812 guidance and interlock of the arm <input type="checkbox"/> <input type="checkbox"/> <input type="checkbox"/> <input type="checkbox"/> <input type="checkbox"/></p> <p>813 „Arm 5“ <input type="checkbox"/> <input type="checkbox"/> <input type="checkbox"/> <input type="checkbox"/> <input type="checkbox"/></p> <p>814 bracket conveying line <input type="checkbox"/> <input type="checkbox"/> <input type="checkbox"/> <input type="checkbox"/> <input type="checkbox"/></p> <p>815 guidance and interlock of the arm <input type="checkbox"/> <input type="checkbox"/> <input type="checkbox"/> <input type="checkbox"/> <input type="checkbox"/></p> <p>900 joint „A“</p> <p>901 boom <input type="checkbox"/> <input type="checkbox"/> <input type="checkbox"/> <input type="checkbox"/> <input type="checkbox"/></p> <p>902 link lever <input type="checkbox"/> <input type="checkbox"/> <input type="checkbox"/> <input type="checkbox"/> <input type="checkbox"/></p> <p>903 forcing rod <input type="checkbox"/> <input type="checkbox"/> <input type="checkbox"/> <input type="checkbox"/> <input type="checkbox"/></p> <p>904 pin <input type="checkbox"/> <input type="checkbox"/> <input type="checkbox"/> <input type="checkbox"/> <input type="checkbox"/></p> <p>905 cylinder <input type="checkbox"/> <input type="checkbox"/> <input type="checkbox"/> <input type="checkbox"/> <input type="checkbox"/></p>	<p>906 boom speed <input type="checkbox"/> <input type="checkbox"/> <input type="checkbox"/> <input type="checkbox"/> <input type="checkbox"/></p> <p>907 pressure settings <input type="checkbox"/> <input type="checkbox"/> <input type="checkbox"/> <input type="checkbox"/> <input type="checkbox"/></p> <p>908 hydraulic lines <input type="checkbox"/> <input type="checkbox"/> <input type="checkbox"/> <input type="checkbox"/> <input type="checkbox"/></p> <p>909 load holding valve (piston side) <input type="checkbox"/> <input type="checkbox"/> <input type="checkbox"/> <input type="checkbox"/> <input type="checkbox"/></p> <p>910 load holding valve (rod side) <input type="checkbox"/> <input type="checkbox"/> <input type="checkbox"/> <input type="checkbox"/> <input type="checkbox"/></p> <p>1000 joint „B“</p> <p>1001 boom <input type="checkbox"/> <input type="checkbox"/> <input type="checkbox"/> <input type="checkbox"/> <input type="checkbox"/></p> <p>1002 link lever <input type="checkbox"/> <input type="checkbox"/> <input type="checkbox"/> <input type="checkbox"/> <input type="checkbox"/></p> <p>1003 forcing rod <input type="checkbox"/> <input type="checkbox"/> <input type="checkbox"/> <input type="checkbox"/> <input type="checkbox"/></p> <p>1004 pin <input type="checkbox"/> <input type="checkbox"/> <input type="checkbox"/> <input type="checkbox"/> <input type="checkbox"/></p> <p>1005 cylinder <input type="checkbox"/> <input type="checkbox"/> <input type="checkbox"/> <input type="checkbox"/> <input type="checkbox"/></p> <p>1006 boom speed <input type="checkbox"/> <input type="checkbox"/> <input type="checkbox"/> <input type="checkbox"/> <input type="checkbox"/></p> <p>1007 pressure settings <input type="checkbox"/> <input type="checkbox"/> <input type="checkbox"/> <input type="checkbox"/> <input type="checkbox"/></p> <p>1008 hydraulic lines <input type="checkbox"/> <input type="checkbox"/> <input type="checkbox"/> <input type="checkbox"/> <input type="checkbox"/></p> <p>1009 load holding valve (piston side) <input type="checkbox"/> <input type="checkbox"/> <input type="checkbox"/> <input type="checkbox"/> <input type="checkbox"/></p> <p>1010 load holding valve (rod side) <input type="checkbox"/> <input type="checkbox"/> <input type="checkbox"/> <input type="checkbox"/> <input type="checkbox"/></p> <p>Notes:</p> <hr/> <hr/> <hr/> <hr/>
--	---

Inspection report for concrete booms

Inspection report Nr: _____ Boom type: _____ Machine-Nr: _____

Error code:			
00 no objections	08 corrosion	16 porous	24 deformation
01 cracks	09 lacquer failures	17 burned through	25 bear movement
02 broken	10 fraying	18 not fixed	26 lubrication
03 leaky	11 scratched	19 clomp	27 readability
04 no function	12 bendet	20 sawing	28 missing components
05 low lifetime	13 noises	21 contaminated	29 hydraulical
06 worn out	14 vibration	22 bad contact	30 electrical
07 dirt	15 miscellaneous	23 temperature	31 reinspection required

1100 joint "C"

1101 boom	<input type="checkbox"/>	<input type="checkbox"/>	<input type="checkbox"/>	<input type="checkbox"/>	<input type="checkbox"/>
1102 link lever	<input type="checkbox"/>	<input type="checkbox"/>	<input type="checkbox"/>	<input type="checkbox"/>	<input type="checkbox"/>
1103 forcing rod	<input type="checkbox"/>	<input type="checkbox"/>	<input type="checkbox"/>	<input type="checkbox"/>	<input type="checkbox"/>
1104 pin	<input type="checkbox"/>	<input type="checkbox"/>	<input type="checkbox"/>	<input type="checkbox"/>	<input type="checkbox"/>
1105 cylinder	<input type="checkbox"/>	<input type="checkbox"/>	<input type="checkbox"/>	<input type="checkbox"/>	<input type="checkbox"/>
1106 boom speed	<input type="checkbox"/>	<input type="checkbox"/>	<input type="checkbox"/>	<input type="checkbox"/>	<input type="checkbox"/>
1107 pressure settings	<input type="checkbox"/>	<input type="checkbox"/>	<input type="checkbox"/>	<input type="checkbox"/>	<input type="checkbox"/>
1108 hydraulic lines	<input type="checkbox"/>	<input type="checkbox"/>	<input type="checkbox"/>	<input type="checkbox"/>	<input type="checkbox"/>
1109 load holding valve (piston side)	<input type="checkbox"/>	<input type="checkbox"/>	<input type="checkbox"/>	<input type="checkbox"/>	<input type="checkbox"/>
1110 load holding valve (rod side)	<input type="checkbox"/>	<input type="checkbox"/>	<input type="checkbox"/>	<input type="checkbox"/>	<input type="checkbox"/>

1200 joint "D"

1201 boom	<input type="checkbox"/>	<input type="checkbox"/>	<input type="checkbox"/>	<input type="checkbox"/>	<input type="checkbox"/>
1202 link lever	<input type="checkbox"/>	<input type="checkbox"/>	<input type="checkbox"/>	<input type="checkbox"/>	<input type="checkbox"/>
1203 forcing rod	<input type="checkbox"/>	<input type="checkbox"/>	<input type="checkbox"/>	<input type="checkbox"/>	<input type="checkbox"/>
1204 pin	<input type="checkbox"/>	<input type="checkbox"/>	<input type="checkbox"/>	<input type="checkbox"/>	<input type="checkbox"/>
1205 cylinder	<input type="checkbox"/>	<input type="checkbox"/>	<input type="checkbox"/>	<input type="checkbox"/>	<input type="checkbox"/>
1206 boom speed	<input type="checkbox"/>	<input type="checkbox"/>	<input type="checkbox"/>	<input type="checkbox"/>	<input type="checkbox"/>
1207 pressure settings	<input type="checkbox"/>	<input type="checkbox"/>	<input type="checkbox"/>	<input type="checkbox"/>	<input type="checkbox"/>
1208 hydraulic lines	<input type="checkbox"/>	<input type="checkbox"/>	<input type="checkbox"/>	<input type="checkbox"/>	<input type="checkbox"/>
1209 load holding valve (piston side)	<input type="checkbox"/>	<input type="checkbox"/>	<input type="checkbox"/>	<input type="checkbox"/>	<input type="checkbox"/>
1210 load holding valve (rod side)	<input type="checkbox"/>	<input type="checkbox"/>	<input type="checkbox"/>	<input type="checkbox"/>	<input type="checkbox"/>

1300 joint „E“

1301 boom	<input type="checkbox"/>	<input type="checkbox"/>	<input type="checkbox"/>	<input type="checkbox"/>	<input type="checkbox"/>
1302 link lever	<input type="checkbox"/>	<input type="checkbox"/>	<input type="checkbox"/>	<input type="checkbox"/>	<input type="checkbox"/>
1303 forcing rod	<input type="checkbox"/>	<input type="checkbox"/>	<input type="checkbox"/>	<input type="checkbox"/>	<input type="checkbox"/>
1304 pin	<input type="checkbox"/>	<input type="checkbox"/>	<input type="checkbox"/>	<input type="checkbox"/>	<input type="checkbox"/>
1305 cylinder	<input type="checkbox"/>	<input type="checkbox"/>	<input type="checkbox"/>	<input type="checkbox"/>	<input type="checkbox"/>
1306 boom speed	<input type="checkbox"/>	<input type="checkbox"/>	<input type="checkbox"/>	<input type="checkbox"/>	<input type="checkbox"/>
1307 pressure settings	<input type="checkbox"/>	<input type="checkbox"/>	<input type="checkbox"/>	<input type="checkbox"/>	<input type="checkbox"/>
1308 hydraulic lines	<input type="checkbox"/>	<input type="checkbox"/>	<input type="checkbox"/>	<input type="checkbox"/>	<input type="checkbox"/>
1309 load holding valve (piston side)	<input type="checkbox"/>	<input type="checkbox"/>	<input type="checkbox"/>	<input type="checkbox"/>	<input type="checkbox"/>
1310 load holding valve (rod side)	<input type="checkbox"/>	<input type="checkbox"/>	<input type="checkbox"/>	<input type="checkbox"/>	<input type="checkbox"/>

1400 concrete delivery line

1401 assembly of delivery line DN	<input type="checkbox"/>	<input type="checkbox"/>	<input type="checkbox"/>	<input type="checkbox"/>	<input type="checkbox"/>
1402 end hose DN+lenght	<input type="checkbox"/>	<input type="checkbox"/>	<input type="checkbox"/>	<input type="checkbox"/>	<input type="checkbox"/>
1403 delivery line DN	<input type="checkbox"/>	<input type="checkbox"/>	<input type="checkbox"/>	<input type="checkbox"/>	<input type="checkbox"/>
1404 rotating joints of - delivery line	<input type="checkbox"/>	<input type="checkbox"/>	<input type="checkbox"/>	<input type="checkbox"/>	<input type="checkbox"/>
1405 locking pin of the coupling	<input type="checkbox"/>	<input type="checkbox"/>	<input type="checkbox"/>	<input type="checkbox"/>	<input type="checkbox"/>

Notes:

Inspection report for concrete booms

Page 5-5

Inspection report Nr: _____ Boom type: _____ Machine-Nr: _____

Error code:

- | | | | |
|------------------|---------------------|-------------------|--------------------------|
| 00 no objections | 08 corrosion | 16 porous | 24 deformation |
| 01 cracks | 09 lacquer failures | 17 burned through | 25 bear movement |
| 02 broken | 10 fraying | 18 not fixed | 26 lubrication |
| 03 leaky | 11 scratched | 19 clemp | 27 readability |
| 04 no function | 12 bendet | 20 sawing | 28 missing components |
| 05 low lifetime | 13 noises | 21 contaminated | 29 hydraulical |
| 06 worn out | 14 vibration | 22 bad contact | 30 electrical |
| 07 dirt | 15 miscellaneous | 23 temperature | 31 reinspection required |

<p>1406 end hose safety device <input type="checkbox"/> <input type="checkbox"/> <input type="checkbox"/> <input type="checkbox"/> <input type="checkbox"/></p> <p>1407 reducer <input type="checkbox"/> <input type="checkbox"/> <input type="checkbox"/> <input type="checkbox"/> <input type="checkbox"/></p> <p>1408 gate elbow, elbow 6" <input type="checkbox"/> <input type="checkbox"/> <input type="checkbox"/> <input type="checkbox"/> <input type="checkbox"/></p> <p>1500 hydraulic system and hydraulic valves</p> <p>1501 Pressure relief valve <input type="checkbox"/> <input type="checkbox"/> <input type="checkbox"/> <input type="checkbox"/> <input type="checkbox"/></p> <p>1502 pressure settings <input type="checkbox"/> <input type="checkbox"/> <input type="checkbox"/> <input type="checkbox"/> <input type="checkbox"/></p> <p>1503 hydraulic lines <input type="checkbox"/> <input type="checkbox"/> <input type="checkbox"/> <input type="checkbox"/> <input type="checkbox"/></p> <p>1504 hand operating- (function) <input type="checkbox"/> <input type="checkbox"/> <input type="checkbox"/> <input type="checkbox"/> <input type="checkbox"/></p> <p>1505 boom control valve <input type="checkbox"/> <input type="checkbox"/> <input type="checkbox"/> <input type="checkbox"/> <input type="checkbox"/></p> <p>1506 hydraulic pump <input type="checkbox"/> <input type="checkbox"/> <input type="checkbox"/> <input type="checkbox"/> <input type="checkbox"/></p> <p>1600 electric equipment</p> <p>1601 remote control (functions) <input type="checkbox"/> <input type="checkbox"/> <input type="checkbox"/> <input type="checkbox"/> <input type="checkbox"/></p> <p>1602 emergency stop (function) <input type="checkbox"/> <input type="checkbox"/> <input type="checkbox"/> <input type="checkbox"/> <input type="checkbox"/></p> <p>1603 switch for outrigger function <input type="checkbox"/> <input type="checkbox"/> <input type="checkbox"/> <input type="checkbox"/> <input type="checkbox"/></p> <p>1604 switch for boom function <input type="checkbox"/> <input type="checkbox"/> <input type="checkbox"/> <input type="checkbox"/> <input type="checkbox"/></p> <p>1605 wiring harness <input type="checkbox"/> <input type="checkbox"/> <input type="checkbox"/> <input type="checkbox"/> <input type="checkbox"/></p> <p>1606 central lubrication <input type="checkbox"/> <input type="checkbox"/> <input type="checkbox"/> <input type="checkbox"/> <input type="checkbox"/></p>	<p>1700 sticker sets</p> <p>1701 safety hints <input type="checkbox"/> <input type="checkbox"/> <input type="checkbox"/> <input type="checkbox"/> <input type="checkbox"/></p> <p>1702 description <input type="checkbox"/> <input type="checkbox"/> <input type="checkbox"/> <input type="checkbox"/> <input type="checkbox"/></p> <p>1703 operating <input type="checkbox"/> <input type="checkbox"/> <input type="checkbox"/> <input type="checkbox"/> <input type="checkbox"/></p> <p>1704 short operating instruction <input type="checkbox"/> <input type="checkbox"/> <input type="checkbox"/> <input type="checkbox"/> <input type="checkbox"/></p> <p>1705 sticker „ don't use the boom as crane“ <input type="checkbox"/> <input type="checkbox"/> <input type="checkbox"/> <input type="checkbox"/> <input type="checkbox"/></p> <p>1706 sticker „guideline operating with boom- and concrete pump“ <input type="checkbox"/> <input type="checkbox"/> <input type="checkbox"/> <input type="checkbox"/> <input type="checkbox"/></p> <p>1707 name plate <input type="checkbox"/> <input type="checkbox"/> <input type="checkbox"/> <input type="checkbox"/> <input type="checkbox"/></p> <p>1708 sticker „danger high voltage“ <input type="checkbox"/> <input type="checkbox"/> <input type="checkbox"/> <input type="checkbox"/> <input type="checkbox"/></p> <p>Competent inspector:</p> <p>Date: _____</p> <p>Name: _____</p> <p>Signature: _____ (stamp)</p> <p>Customer:</p> <p>Signature: _____ (stamp)</p>
---	--

Inspection report for concrete pump

Inspection report Nr:	Machine-Nr:	Hours of operation:
		Concrete output m ³ :
Company:	Post code:	City:

NL	WV
----	----

Proof – Result of the tests

without defects	defects	reinspection required	shut down
<input type="checkbox"/>	<input type="checkbox"/>	<input type="checkbox"/>	<input type="checkbox"/>

Reinspection until date:

Error code:

- | | | | |
|------------------|---------------------|-------------------|--------------------------|
| 00 no objections | 08 corrosion | 16 porous | 24 deformation |
| 01 cracks | 09 lacquer failures | 17 burned through | 25 bear movement |
| 02 broken | 10 fraying | 18 not fixed | 26 lubrication |
| 03 leaky | 11 scratched | 19 clomp | 27 readability |
| 04 no fuction | 12 bendet | 20 sawing | 28 missing components |
| 05 low livetime | 13 noises | 21 contaminated | 29 hydraulical |
| 06 worn out | 14 vibration | 22 bad contact | 30 electrical |
| 07 dirt | 15 miscellaneous | 23 temperature | 31 reinspection required |

2000 documents

2001 operating manual	<input type="checkbox"/>	<input type="checkbox"/>	<input type="checkbox"/>	<input type="checkbox"/>	<input type="checkbox"/>
2002 spare parts list	<input type="checkbox"/>	<input type="checkbox"/>	<input type="checkbox"/>	<input type="checkbox"/>	<input type="checkbox"/>

2100 drive assembly

2101 coupling and flange	<input type="checkbox"/>	<input type="checkbox"/>	<input type="checkbox"/>	<input type="checkbox"/>	<input type="checkbox"/>
--------------------------	--------------------------	--------------------------	--------------------------	--------------------------	--------------------------

2200 gear box

<input type="checkbox"/>	<input type="checkbox"/>	<input type="checkbox"/>	<input type="checkbox"/>	<input type="checkbox"/>
--------------------------	--------------------------	--------------------------	--------------------------	--------------------------

2300 hydraulic pump (main)

<input type="checkbox"/>	<input type="checkbox"/>	<input type="checkbox"/>	<input type="checkbox"/>	<input type="checkbox"/>
--------------------------	--------------------------	--------------------------	--------------------------	--------------------------

2400 oil-tank

<input type="checkbox"/>	<input type="checkbox"/>	<input type="checkbox"/>	<input type="checkbox"/>	<input type="checkbox"/>
--------------------------	--------------------------	--------------------------	--------------------------	--------------------------

2500 drive shaft

<input type="checkbox"/>	<input type="checkbox"/>	<input type="checkbox"/>	<input type="checkbox"/>	<input type="checkbox"/>
--------------------------	--------------------------	--------------------------	--------------------------	--------------------------

2700 hydraulic control system

2701 pressure relief valve	<input type="checkbox"/>	<input type="checkbox"/>	<input type="checkbox"/>	<input type="checkbox"/>	<input type="checkbox"/>
----------------------------	--------------------------	--------------------------	--------------------------	--------------------------	--------------------------

2702 pressure setting	<input type="checkbox"/>	<input type="checkbox"/>	<input type="checkbox"/>	<input type="checkbox"/>	<input type="checkbox"/>
-----------------------	--------------------------	--------------------------	--------------------------	--------------------------	--------------------------

2703 hydraulic line	<input type="checkbox"/>	<input type="checkbox"/>	<input type="checkbox"/>	<input type="checkbox"/>	<input type="checkbox"/>
---------------------	--------------------------	--------------------------	--------------------------	--------------------------	--------------------------

2704 mechanical operation by hand	<input type="checkbox"/>	<input type="checkbox"/>	<input type="checkbox"/>	<input type="checkbox"/>	<input type="checkbox"/>
-----------------------------------	--------------------------	--------------------------	--------------------------	--------------------------	--------------------------

2800 oil –cooler	<input type="checkbox"/>	<input type="checkbox"/>	<input type="checkbox"/>	<input type="checkbox"/>	<input type="checkbox"/>
------------------	--------------------------	--------------------------	--------------------------	--------------------------	--------------------------

2900 accumulator	<input type="checkbox"/>	<input type="checkbox"/>	<input type="checkbox"/>	<input type="checkbox"/>	<input type="checkbox"/>
------------------	--------------------------	--------------------------	--------------------------	--------------------------	--------------------------

2901 proofs of the required tests according to accumulator regulation	<input type="checkbox"/>	<input type="checkbox"/>	<input type="checkbox"/>	<input type="checkbox"/>	<input type="checkbox"/>
---	--------------------------	--------------------------	--------------------------	--------------------------	--------------------------

2902 pressure gauge	<input type="checkbox"/>	<input type="checkbox"/>	<input type="checkbox"/>	<input type="checkbox"/>	<input type="checkbox"/>
---------------------	--------------------------	--------------------------	--------------------------	--------------------------	--------------------------

Notes:

Inspection report for concrete pump

Inspection report Nr: _____ Machine-Nr: _____

Error code:

- | | | | |
|------------------|---------------------|-------------------|--------------------------|
| 00 no objections | 08 corrosion | 16 porous | 24 deformation |
| 01 cracks | 09 lacquer failures | 17 burned through | 25 bear movement |
| 02 broken | 10 fraying | 18 not fixed | 26 lubrication |
| 03 leaky | 11 scratched | 19 clemp | 27 readability |
| 04 no function | 12 bendet | 20 sawing | 28 missing components |
| 05 low lifetime | 13 noises | 21 contamitated | 29 hydraulical |
| 06 worn out | 14 vibration | 22 bad contact | 30 electrical |
| 07 dirt | 15 miscellaneous | 23 temperature | 31 reinspection required |

<p>3000 central lubrication <input type="checkbox"/> <input type="checkbox"/> <input type="checkbox"/> <input type="checkbox"/> <input type="checkbox"/></p> <p>3100 hydraulic motor <input type="checkbox"/> <input type="checkbox"/> <input type="checkbox"/> <input type="checkbox"/> <input type="checkbox"/></p> <p>3200 hydraulic lines <input type="checkbox"/> <input type="checkbox"/> <input type="checkbox"/> <input type="checkbox"/> <input type="checkbox"/></p> <p>3300 air compressor <input type="checkbox"/> <input type="checkbox"/> <input type="checkbox"/> <input type="checkbox"/> <input type="checkbox"/></p> <p>3400 control panel <input type="checkbox"/> <input type="checkbox"/> <input type="checkbox"/> <input type="checkbox"/> <input type="checkbox"/></p> <p>3500 concrete pump <input type="checkbox"/> <input type="checkbox"/> <input type="checkbox"/> <input type="checkbox"/> <input type="checkbox"/></p> <p>3700 S-valve <input type="checkbox"/> <input type="checkbox"/> <input type="checkbox"/> <input type="checkbox"/> <input type="checkbox"/></p> <p>3800 hopper <input type="checkbox"/> <input type="checkbox"/> <input type="checkbox"/> <input type="checkbox"/> <input type="checkbox"/></p> <p>4100 sub frame <input type="checkbox"/> <input type="checkbox"/> <input type="checkbox"/> <input type="checkbox"/> <input type="checkbox"/></p> <p>4200 water tank <input type="checkbox"/> <input type="checkbox"/> <input type="checkbox"/> <input type="checkbox"/> <input type="checkbox"/></p> <p>4300 axle <input type="checkbox"/> <input type="checkbox"/> <input type="checkbox"/> <input type="checkbox"/> <input type="checkbox"/></p> <p>4400 water pump <input type="checkbox"/> <input type="checkbox"/> <input type="checkbox"/> <input type="checkbox"/> <input type="checkbox"/></p> <p>4500 vibrator <input type="checkbox"/> <input type="checkbox"/> <input type="checkbox"/> <input type="checkbox"/> <input type="checkbox"/></p>	<p>4600 safety guards, equipment</p> <p>4601 stair <input type="checkbox"/> <input type="checkbox"/> <input type="checkbox"/> <input type="checkbox"/> <input type="checkbox"/></p> <p>4602 safety for stair <input type="checkbox"/> <input type="checkbox"/> <input type="checkbox"/> <input type="checkbox"/> <input type="checkbox"/></p> <p>4603 handrail <input type="checkbox"/> <input type="checkbox"/> <input type="checkbox"/> <input type="checkbox"/> <input type="checkbox"/></p> <p>4604 hopper grid (fixing device) <input type="checkbox"/> <input type="checkbox"/> <input type="checkbox"/> <input type="checkbox"/> <input type="checkbox"/></p> <p>4606 distance of grid rods <input type="checkbox"/> <input type="checkbox"/> <input type="checkbox"/> <input type="checkbox"/> <input type="checkbox"/></p> <p>4607 distance from grid to agitator <input type="checkbox"/> <input type="checkbox"/> <input type="checkbox"/> <input type="checkbox"/> <input type="checkbox"/></p> <p>4609 agitator have to stop if grid is open <input type="checkbox"/> <input type="checkbox"/> <input type="checkbox"/> <input type="checkbox"/> <input type="checkbox"/></p> <p>4610 accumulator have to dump if grid is open <input type="checkbox"/> <input type="checkbox"/> <input type="checkbox"/> <input type="checkbox"/> <input type="checkbox"/></p> <p>4612 cleaning flap hopper <input type="checkbox"/> <input type="checkbox"/> <input type="checkbox"/> <input type="checkbox"/> <input type="checkbox"/></p> <p>4613 safety grid into water box <input type="checkbox"/> <input type="checkbox"/> <input type="checkbox"/> <input type="checkbox"/> <input type="checkbox"/></p>
--	---

Notes:

Inspection report for concrete pump

Page 3-3

Inspection report Nr:

Machine-Nr:

Error code:

00 no objections	08 corrosion	16 porous	24 deformation
01 cracks	09 lacquer failures	17 burned through	25 bear movement
02 broken	10 fraying	18 not fixed	26 lubrication
03 leaky	11 scratched	19 clemp	27 readability
04 no function	12 bendet	20 sawing	28 missing components
05 low lifetime	13 noises	21 contamitated	29 hydraulical
06 worn out	14 vibration	22 bad contact	30 electrical
07 dirt	15 miscellaneous	23 temperature	31 reinspection required

4614 cover for rotating wave

4616 cover for chains

4617 cover for shift cylinder

4618 cover for moving parts

4619 cover for the exhaust pipe

4700 electrical system

4701 function of actuator component

4702 emergency stop function

4703 ground connections

4704 cables and wiring harness

4705 temperature switch

4800 outrigger - system

4801 transportation lock

4802 locking device

4803 backing plate

4804 jack cylinder connections

4805 pressure adjustment of jack cylinder

4900 miscellaneous

4901 additional assembled part from operator

4902 changes through operator

Competent inspector:

Date:

Name:

Signature:
(stamp)

Customer:

Signature:
(stamp)

This test report is filed into the test book

Inspection report for concrete booms

Inspection report -Nr:	Machine-Nr	Hours of operation:
		Concrete output m ³ :
Company:	Post code:	City:
Boom Type:	Boom Nr.	NL WV

Proof – Result of the Tests

without defects	defects	reinspection required	shut down
<input type="checkbox"/>	<input type="checkbox"/>	<input type="checkbox"/>	<input type="checkbox"/>

Reinspection until date:

Error code:

- | | | | |
|------------------|---------------------|-------------------|--------------------------|
| 00 no objections | 08 corrosion | 16 porous | 24 deformation |
| 01 cracks | 09 lacquer failures | 17 burned through | 25 bear movement |
| 02 broken | 10 fraying | 18 not fixed | 26 lubrication |
| 03 leaky | 11 scratched | 19 clemp | 27 readability |
| 04 no function | 12 bendet | 20 sawing | 28 missing components |
| 05 low lifetime | 13 noises | 21 contaminated | 29 hydraulic |
| 06 worn out | 14 vibration | 22 bad contact | 30 electrical |
| 07 dirt | 15 miscellaneous | 23 temperature | 31 reinspection required |

<p>100 documents</p> <p>101 instruction manual <input type="checkbox"/> <input type="checkbox"/> <input type="checkbox"/> <input type="checkbox"/> <input type="checkbox"/></p> <p>102 spare parts list <input type="checkbox"/> <input type="checkbox"/> <input type="checkbox"/> <input type="checkbox"/> <input type="checkbox"/></p> <p>200 sub frame</p> <p>201 frame connection cpl. <input type="checkbox"/> <input type="checkbox"/> <input type="checkbox"/> <input type="checkbox"/> <input type="checkbox"/></p> <p>300 outrigger front R+L</p> <p>301 transportation safety device <input type="checkbox"/> <input type="checkbox"/> <input type="checkbox"/> <input type="checkbox"/> <input type="checkbox"/></p> <p>302 outrigger <input type="checkbox"/> <input type="checkbox"/> <input type="checkbox"/> <input type="checkbox"/> <input type="checkbox"/></p> <p>303 extension box <input type="checkbox"/> <input type="checkbox"/> <input type="checkbox"/> <input type="checkbox"/> <input type="checkbox"/></p> <p>304 locking device <input type="checkbox"/> <input type="checkbox"/> <input type="checkbox"/> <input type="checkbox"/> <input type="checkbox"/></p> <p>305 slewing bearing <input type="checkbox"/> <input type="checkbox"/> <input type="checkbox"/> <input type="checkbox"/> <input type="checkbox"/></p> <p>306 turn locking device <input type="checkbox"/> <input type="checkbox"/> <input type="checkbox"/> <input type="checkbox"/> <input type="checkbox"/></p> <p>307 support safeguard <input type="checkbox"/> <input type="checkbox"/> <input type="checkbox"/> <input type="checkbox"/> <input type="checkbox"/></p> <p>308 support plate <input type="checkbox"/> <input type="checkbox"/> <input type="checkbox"/> <input type="checkbox"/> <input type="checkbox"/></p> <p>309 fixing of jack cylinder <input type="checkbox"/> <input type="checkbox"/> <input type="checkbox"/> <input type="checkbox"/> <input type="checkbox"/></p> <p>310 jack cylinder <input type="checkbox"/> <input type="checkbox"/> <input type="checkbox"/> <input type="checkbox"/> <input type="checkbox"/></p>	<p>311 swing cylinder <input type="checkbox"/> <input type="checkbox"/> <input type="checkbox"/> <input type="checkbox"/> <input type="checkbox"/></p> <p>312 telescopic-cylinder <input type="checkbox"/> <input type="checkbox"/> <input type="checkbox"/> <input type="checkbox"/> <input type="checkbox"/></p> <p>313 pressure adjustment <input type="checkbox"/> <input type="checkbox"/> <input type="checkbox"/> <input type="checkbox"/> <input type="checkbox"/></p> <p>400 outrigger rear L+R</p> <p>401 transportation safety device <input type="checkbox"/> <input type="checkbox"/> <input type="checkbox"/> <input type="checkbox"/> <input type="checkbox"/></p> <p>402 outrigger <input type="checkbox"/> <input type="checkbox"/> <input type="checkbox"/> <input type="checkbox"/> <input type="checkbox"/></p> <p>403 extension box <input type="checkbox"/> <input type="checkbox"/> <input type="checkbox"/> <input type="checkbox"/> <input type="checkbox"/></p> <p>405 locking device <input type="checkbox"/> <input type="checkbox"/> <input type="checkbox"/> <input type="checkbox"/> <input type="checkbox"/></p> <p>Notes:</p> <hr/> <hr/> <hr/> <hr/> <hr/>
--	---

Inspection report for concrete booms

Inspection report Nr: _____ Boom type: _____ Machine-Nr: _____

Error code:

- | | | | |
|------------------|---------------------|-------------------|--------------------------|
| 00 no objections | 08 corrosion | 16 porous | 24 deformation |
| 01 cracks | 09 lacquer failures | 17 burned through | 25 bear movement |
| 02 broken | 10 fraying | 18 not fixed | 26 lubrication |
| 03 leaky | 11 scratched | 19 clemp | 27 readability |
| 04 no function | 12 bendet | 20 sawing | 28 missing components |
| 05 low lifetime | 13 noises | 21 contaminated | 29 hydraulical |
| 06 worn out | 14 vibration | 22 bad contact | 30 electrical |
| 07 dirt | 15 miscellaneous | 23 temperature | 31 reinspection required |

<p>406 slewing bearing <input type="checkbox"/> <input type="checkbox"/> <input type="checkbox"/> <input type="checkbox"/> <input type="checkbox"/></p> <p>407 turn locking device <input type="checkbox"/> <input type="checkbox"/> <input type="checkbox"/> <input type="checkbox"/> <input type="checkbox"/></p> <p>408 support safeguard <input type="checkbox"/> <input type="checkbox"/> <input type="checkbox"/> <input type="checkbox"/> <input type="checkbox"/></p> <p>409 support plate <input type="checkbox"/> <input type="checkbox"/> <input type="checkbox"/> <input type="checkbox"/> <input type="checkbox"/></p> <p>410 fixing of jack cylinder <input type="checkbox"/> <input type="checkbox"/> <input type="checkbox"/> <input type="checkbox"/> <input type="checkbox"/></p> <p>411 jack cylinder <input type="checkbox"/> <input type="checkbox"/> <input type="checkbox"/> <input type="checkbox"/> <input type="checkbox"/></p> <p>412 swing cylinder <input type="checkbox"/> <input type="checkbox"/> <input type="checkbox"/> <input type="checkbox"/> <input type="checkbox"/></p> <p>413 telescopic cylinder <input type="checkbox"/> <input type="checkbox"/> <input type="checkbox"/> <input type="checkbox"/> <input type="checkbox"/></p> <p>500 pedestal</p> <p>501 pedestal mounting <input type="checkbox"/> <input type="checkbox"/> <input type="checkbox"/> <input type="checkbox"/> <input type="checkbox"/></p> <p>502 sub frame <input type="checkbox"/> <input type="checkbox"/> <input type="checkbox"/> <input type="checkbox"/> <input type="checkbox"/></p> <p>503 truck frame <input type="checkbox"/> <input type="checkbox"/> <input type="checkbox"/> <input type="checkbox"/> <input type="checkbox"/></p> <p>504 pedestal (structure) <input type="checkbox"/> <input type="checkbox"/> <input type="checkbox"/> <input type="checkbox"/> <input type="checkbox"/></p> <p>505 boom valve without leaking <input type="checkbox"/> <input type="checkbox"/> <input type="checkbox"/> <input type="checkbox"/> <input type="checkbox"/></p> <p>506 boom rest <input type="checkbox"/> <input type="checkbox"/> <input type="checkbox"/> <input type="checkbox"/> <input type="checkbox"/></p> <p>507 transportation safety device <input type="checkbox"/> <input type="checkbox"/> <input type="checkbox"/> <input type="checkbox"/> <input type="checkbox"/></p> <p>508 hydraulic line <input type="checkbox"/> <input type="checkbox"/> <input type="checkbox"/> <input type="checkbox"/> <input type="checkbox"/></p> <p>600 slewing head with ball pivot</p> <p>601 slewing head <input type="checkbox"/> <input type="checkbox"/> <input type="checkbox"/> <input type="checkbox"/> <input type="checkbox"/></p> <p>602 ball pivot ring <input type="checkbox"/> <input type="checkbox"/> <input type="checkbox"/> <input type="checkbox"/> <input type="checkbox"/></p> <p>603 mounting ball pivot ring <input type="checkbox"/> <input type="checkbox"/> <input type="checkbox"/> <input type="checkbox"/> <input type="checkbox"/></p> <p>604 drive pinion <input type="checkbox"/> <input type="checkbox"/> <input type="checkbox"/> <input type="checkbox"/> <input type="checkbox"/></p>	<p>605 slewing drive mounting <input type="checkbox"/> <input type="checkbox"/> <input type="checkbox"/> <input type="checkbox"/> <input type="checkbox"/></p> <p>606 slewing stop device <input type="checkbox"/> <input type="checkbox"/> <input type="checkbox"/> <input type="checkbox"/> <input type="checkbox"/></p> <p>607 slewing drive (tooth backlash) <input type="checkbox"/> <input type="checkbox"/> <input type="checkbox"/> <input type="checkbox"/> <input type="checkbox"/></p> <p>608 slewing drive <input type="checkbox"/> <input type="checkbox"/> <input type="checkbox"/> <input type="checkbox"/> <input type="checkbox"/></p> <p>609 brake function <input type="checkbox"/> <input type="checkbox"/> <input type="checkbox"/> <input type="checkbox"/> <input type="checkbox"/></p> <p>610 speed <input type="checkbox"/> <input type="checkbox"/> <input type="checkbox"/> <input type="checkbox"/> <input type="checkbox"/></p> <p>611 pressure setting <input type="checkbox"/> <input type="checkbox"/> <input type="checkbox"/> <input type="checkbox"/> <input type="checkbox"/></p> <p>612 hydraulic lines <input type="checkbox"/> <input type="checkbox"/> <input type="checkbox"/> <input type="checkbox"/> <input type="checkbox"/></p> <p>700 slewing head with slewing column</p> <p>701 slewing head <input type="checkbox"/> <input type="checkbox"/> <input type="checkbox"/> <input type="checkbox"/> <input type="checkbox"/></p> <p>702 slewing column bearing <input type="checkbox"/> <input type="checkbox"/> <input type="checkbox"/> <input type="checkbox"/> <input type="checkbox"/></p> <p>703 slewing drive (tooth backlash) <input type="checkbox"/> <input type="checkbox"/> <input type="checkbox"/> <input type="checkbox"/> <input type="checkbox"/></p> <p>704 speed <input type="checkbox"/> <input type="checkbox"/> <input type="checkbox"/> <input type="checkbox"/> <input type="checkbox"/></p> <p>705 pressure settings <input type="checkbox"/> <input type="checkbox"/> <input type="checkbox"/> <input type="checkbox"/> <input type="checkbox"/></p> <p>706 hydraulic lines <input type="checkbox"/> <input type="checkbox"/> <input type="checkbox"/> <input type="checkbox"/> <input type="checkbox"/></p> <p>707 swivel cylinder <input type="checkbox"/> <input type="checkbox"/> <input type="checkbox"/> <input type="checkbox"/> <input type="checkbox"/></p> <p>Notes:</p> <hr/> <hr/> <hr/> <hr/>
---	---

Inspection report for concrete booms

Inspection report Nr:	Boom type:	Machine-Nr:
-----------------------	------------	-------------

Error code:

00 no objections	08 corrosion	16 porous	24 deformation
01 cracks	09 lacquer failures	17 burned through	25 bear movement
02 broken	10 fraying	18 not fixed	26 lubrication
03 leaky	11 scratched	19 clomp	27 readability
04 no function	12 bendet	20 sawing	28 missing components
05 low lifetime	13 noises	21 contaminated	29 hydraulical
06 worn out	14 vibration	22 bad contact	30 electrical
07 dirt	15 miscellaneous	23 temperature	31 reinspection required

<p>800 boom</p> <p>801 „Arm 1“ <input type="checkbox"/> <input type="checkbox"/> <input type="checkbox"/> <input type="checkbox"/> <input type="checkbox"/></p> <p>802 bracket conveying line <input type="checkbox"/> <input type="checkbox"/> <input type="checkbox"/> <input type="checkbox"/> <input type="checkbox"/></p> <p>803 Drop hook <input type="checkbox"/> <input type="checkbox"/> <input type="checkbox"/> <input type="checkbox"/> <input type="checkbox"/></p> <p>804 „Arm 2“ <input type="checkbox"/> <input type="checkbox"/> <input type="checkbox"/> <input type="checkbox"/> <input type="checkbox"/></p> <p>805 bracket conveying line <input type="checkbox"/> <input type="checkbox"/> <input type="checkbox"/> <input type="checkbox"/> <input type="checkbox"/></p> <p>806 Drop hook <input type="checkbox"/> <input type="checkbox"/> <input type="checkbox"/> <input type="checkbox"/> <input type="checkbox"/></p> <p>807 „Arm 3“ <input type="checkbox"/> <input type="checkbox"/> <input type="checkbox"/> <input type="checkbox"/> <input type="checkbox"/></p> <p>808 bracket conveying line <input type="checkbox"/> <input type="checkbox"/> <input type="checkbox"/> <input type="checkbox"/> <input type="checkbox"/></p> <p>809 guidance and interlock of the arm <input type="checkbox"/> <input type="checkbox"/> <input type="checkbox"/> <input type="checkbox"/> <input type="checkbox"/></p> <p>810 „Arm 4“ <input type="checkbox"/> <input type="checkbox"/> <input type="checkbox"/> <input type="checkbox"/> <input type="checkbox"/></p> <p>811 bracket conveying line <input type="checkbox"/> <input type="checkbox"/> <input type="checkbox"/> <input type="checkbox"/> <input type="checkbox"/></p> <p>812 guidance and interlock of the arm <input type="checkbox"/> <input type="checkbox"/> <input type="checkbox"/> <input type="checkbox"/> <input type="checkbox"/></p> <p>813 „Arm 5“ <input type="checkbox"/> <input type="checkbox"/> <input type="checkbox"/> <input type="checkbox"/> <input type="checkbox"/></p> <p>814 bracket conveying line <input type="checkbox"/> <input type="checkbox"/> <input type="checkbox"/> <input type="checkbox"/> <input type="checkbox"/></p> <p>815 guidance and interlock of the arm <input type="checkbox"/> <input type="checkbox"/> <input type="checkbox"/> <input type="checkbox"/> <input type="checkbox"/></p> <p>900 joint „A“</p> <p>901 boom <input type="checkbox"/> <input type="checkbox"/> <input type="checkbox"/> <input type="checkbox"/> <input type="checkbox"/></p> <p>902 link lever <input type="checkbox"/> <input type="checkbox"/> <input type="checkbox"/> <input type="checkbox"/> <input type="checkbox"/></p> <p>903 forcing rod <input type="checkbox"/> <input type="checkbox"/> <input type="checkbox"/> <input type="checkbox"/> <input type="checkbox"/></p> <p>904 pin <input type="checkbox"/> <input type="checkbox"/> <input type="checkbox"/> <input type="checkbox"/> <input type="checkbox"/></p> <p>905 cylinder <input type="checkbox"/> <input type="checkbox"/> <input type="checkbox"/> <input type="checkbox"/> <input type="checkbox"/></p>	<p>906 boom speed <input type="checkbox"/> <input type="checkbox"/> <input type="checkbox"/> <input type="checkbox"/> <input type="checkbox"/></p> <p>907 pressure settings <input type="checkbox"/> <input type="checkbox"/> <input type="checkbox"/> <input type="checkbox"/> <input type="checkbox"/></p> <p>908 hydraulic lines <input type="checkbox"/> <input type="checkbox"/> <input type="checkbox"/> <input type="checkbox"/> <input type="checkbox"/></p> <p>909 load holding valve (piston side) <input type="checkbox"/> <input type="checkbox"/> <input type="checkbox"/> <input type="checkbox"/> <input type="checkbox"/></p> <p>910 load holding valve (rod side) <input type="checkbox"/> <input type="checkbox"/> <input type="checkbox"/> <input type="checkbox"/> <input type="checkbox"/></p> <p>1000 joint „B“</p> <p>1001 boom <input type="checkbox"/> <input type="checkbox"/> <input type="checkbox"/> <input type="checkbox"/> <input type="checkbox"/></p> <p>1002 link lever <input type="checkbox"/> <input type="checkbox"/> <input type="checkbox"/> <input type="checkbox"/> <input type="checkbox"/></p> <p>1003 forcing rod <input type="checkbox"/> <input type="checkbox"/> <input type="checkbox"/> <input type="checkbox"/> <input type="checkbox"/></p> <p>1004 pin <input type="checkbox"/> <input type="checkbox"/> <input type="checkbox"/> <input type="checkbox"/> <input type="checkbox"/></p> <p>1005 cylinder <input type="checkbox"/> <input type="checkbox"/> <input type="checkbox"/> <input type="checkbox"/> <input type="checkbox"/></p> <p>1006 boom speed <input type="checkbox"/> <input type="checkbox"/> <input type="checkbox"/> <input type="checkbox"/> <input type="checkbox"/></p> <p>1007 pressure settings <input type="checkbox"/> <input type="checkbox"/> <input type="checkbox"/> <input type="checkbox"/> <input type="checkbox"/></p> <p>1008 hydraulic lines <input type="checkbox"/> <input type="checkbox"/> <input type="checkbox"/> <input type="checkbox"/> <input type="checkbox"/></p> <p>1009 load holding valve (piston side) <input type="checkbox"/> <input type="checkbox"/> <input type="checkbox"/> <input type="checkbox"/> <input type="checkbox"/></p> <p>1010 load holding valve (rod side) <input type="checkbox"/> <input type="checkbox"/> <input type="checkbox"/> <input type="checkbox"/> <input type="checkbox"/></p> <p>Notes:</p> <hr/> <hr/> <hr/> <hr/>
--	---

Inspection report for concrete booms

Inspection report Nr: _____ Boom type: _____ Machine-Nr: _____

- | | | | |
|------------------|---------------------|-------------------|--------------------------|
| Error code: | | | |
| 00 no objections | 08 corrosion | 16 porous | 24 deformation |
| 01 cracks | 09 lacquer failures | 17 burned through | 25 bear movement |
| 02 broken | 10 fraying | 18 not fixed | 26 lubrication |
| 03 leaky | 11 scratched | 19 clomp | 27 readability |
| 04 no function | 12 bendet | 20 sawing | 28 missing components |
| 05 low lifetime | 13 noises | 21 contaminated | 29 hydraulical |
| 06 worn out | 14 vibration | 22 bad contact | 30 electrical |
| 07 dirt | 15 miscellaneous | 23 temperature | 31 reinspection required |

<p>1100 joint "C"</p> <p>1101 boom <input type="checkbox"/> <input type="checkbox"/> <input type="checkbox"/> <input type="checkbox"/> <input type="checkbox"/></p> <p>1102 link lever <input type="checkbox"/> <input type="checkbox"/> <input type="checkbox"/> <input type="checkbox"/> <input type="checkbox"/></p> <p>1103 forcing rod <input type="checkbox"/> <input type="checkbox"/> <input type="checkbox"/> <input type="checkbox"/> <input type="checkbox"/></p> <p>1104 pin <input type="checkbox"/> <input type="checkbox"/> <input type="checkbox"/> <input type="checkbox"/> <input type="checkbox"/></p> <p>1105 cylinder <input type="checkbox"/> <input type="checkbox"/> <input type="checkbox"/> <input type="checkbox"/> <input type="checkbox"/></p> <p>1106 boom speed <input type="checkbox"/> <input type="checkbox"/> <input type="checkbox"/> <input type="checkbox"/> <input type="checkbox"/></p> <p>1107 pressure settings <input type="checkbox"/> <input type="checkbox"/> <input type="checkbox"/> <input type="checkbox"/> <input type="checkbox"/></p> <p>1108 hydraulic lines <input type="checkbox"/> <input type="checkbox"/> <input type="checkbox"/> <input type="checkbox"/> <input type="checkbox"/></p> <p>1109 load holding valve (piston side) <input type="checkbox"/> <input type="checkbox"/> <input type="checkbox"/> <input type="checkbox"/> <input type="checkbox"/></p> <p>1110 load holding valve (rod side) <input type="checkbox"/> <input type="checkbox"/> <input type="checkbox"/> <input type="checkbox"/> <input type="checkbox"/></p> <p>1200 joint "D"</p> <p>1201 boom <input type="checkbox"/> <input type="checkbox"/> <input type="checkbox"/> <input type="checkbox"/> <input type="checkbox"/></p> <p>1202 link lever <input type="checkbox"/> <input type="checkbox"/> <input type="checkbox"/> <input type="checkbox"/> <input type="checkbox"/></p> <p>1203 forcing rod <input type="checkbox"/> <input type="checkbox"/> <input type="checkbox"/> <input type="checkbox"/> <input type="checkbox"/></p> <p>1204 pin <input type="checkbox"/> <input type="checkbox"/> <input type="checkbox"/> <input type="checkbox"/> <input type="checkbox"/></p> <p>1205 cylinder <input type="checkbox"/> <input type="checkbox"/> <input type="checkbox"/> <input type="checkbox"/> <input type="checkbox"/></p> <p>1206 boom speed <input type="checkbox"/> <input type="checkbox"/> <input type="checkbox"/> <input type="checkbox"/> <input type="checkbox"/></p> <p>1207 pressure settings <input type="checkbox"/> <input type="checkbox"/> <input type="checkbox"/> <input type="checkbox"/> <input type="checkbox"/></p> <p>1208 hydraulic lines <input type="checkbox"/> <input type="checkbox"/> <input type="checkbox"/> <input type="checkbox"/> <input type="checkbox"/></p> <p>1209 load holding valve (piston side) <input type="checkbox"/> <input type="checkbox"/> <input type="checkbox"/> <input type="checkbox"/> <input type="checkbox"/></p> <p>1210 load holding valve (rod side) <input type="checkbox"/> <input type="checkbox"/> <input type="checkbox"/> <input type="checkbox"/> <input type="checkbox"/></p>	<p>1300 joint „E“</p> <p>1301 boom <input type="checkbox"/> <input type="checkbox"/> <input type="checkbox"/> <input type="checkbox"/> <input type="checkbox"/></p> <p>1302 link lever <input type="checkbox"/> <input type="checkbox"/> <input type="checkbox"/> <input type="checkbox"/> <input type="checkbox"/></p> <p>1303 forcing rod <input type="checkbox"/> <input type="checkbox"/> <input type="checkbox"/> <input type="checkbox"/> <input type="checkbox"/></p> <p>1304 pin <input type="checkbox"/> <input type="checkbox"/> <input type="checkbox"/> <input type="checkbox"/> <input type="checkbox"/></p> <p>1305 cylinder <input type="checkbox"/> <input type="checkbox"/> <input type="checkbox"/> <input type="checkbox"/> <input type="checkbox"/></p> <p>1306 boom speed <input type="checkbox"/> <input type="checkbox"/> <input type="checkbox"/> <input type="checkbox"/> <input type="checkbox"/></p> <p>1307 pressure settings <input type="checkbox"/> <input type="checkbox"/> <input type="checkbox"/> <input type="checkbox"/> <input type="checkbox"/></p> <p>1308 hydraulic lines <input type="checkbox"/> <input type="checkbox"/> <input type="checkbox"/> <input type="checkbox"/> <input type="checkbox"/></p> <p>1309 load holding valve (piston side) <input type="checkbox"/> <input type="checkbox"/> <input type="checkbox"/> <input type="checkbox"/> <input type="checkbox"/></p> <p>1310 load holding valve (rod side) <input type="checkbox"/> <input type="checkbox"/> <input type="checkbox"/> <input type="checkbox"/> <input type="checkbox"/></p> <p>1400 concrete delivery line</p> <p>1401 assembly of delivery line DN <input type="checkbox"/> <input type="checkbox"/> <input type="checkbox"/> <input type="checkbox"/> <input type="checkbox"/></p> <p>1402 end hose DN+lenght <input type="checkbox"/> <input type="checkbox"/> <input type="checkbox"/> <input type="checkbox"/> <input type="checkbox"/></p> <p>1403 delivery line DN <input type="checkbox"/> <input type="checkbox"/> <input type="checkbox"/> <input type="checkbox"/> <input type="checkbox"/></p> <p>1404 rotating joints of - delivery line <input type="checkbox"/> <input type="checkbox"/> <input type="checkbox"/> <input type="checkbox"/> <input type="checkbox"/></p> <p>1405 locking pin of the coupling <input type="checkbox"/> <input type="checkbox"/> <input type="checkbox"/> <input type="checkbox"/> <input type="checkbox"/></p> <p>Notes:</p> <hr/> <hr/> <hr/>
---	--

Inspection report for concrete booms

Inspection report Nr: _____ Boom type: _____ Machine-Nr: _____

Error code:

00 no objections	08 corrosion	16 porous	24 deformation
01 cracks	09 lacquer failures	17 burned through	25 bear movement
02 broken	10 fraying	18 not fixed	26 lubrication
03 leaky	11 scratched	19 clomp	27 readability
04 no function	12 bendet	20 sawing	28 missing components
05 low lifetime	13 noises	21 contaminated	29 hydraulical
06 worn out	14 vibration	22 bad contact	30 electrical
07 dirt	15 miscellaneous	23 temperature	31 reinspection required

<p>1406 end hose safety device <input type="checkbox"/> <input type="checkbox"/> <input type="checkbox"/> <input type="checkbox"/> <input type="checkbox"/></p> <p>1407 reducer <input type="checkbox"/> <input type="checkbox"/> <input type="checkbox"/> <input type="checkbox"/> <input type="checkbox"/></p> <p>1408 gate elbow, elbow 6" <input type="checkbox"/> <input type="checkbox"/> <input type="checkbox"/> <input type="checkbox"/> <input type="checkbox"/></p> <p>1500 hydraulic system and hydraulic valves</p> <p>1501 Pressure relief valve <input type="checkbox"/> <input type="checkbox"/> <input type="checkbox"/> <input type="checkbox"/> <input type="checkbox"/></p> <p>1502 pressure settings <input type="checkbox"/> <input type="checkbox"/> <input type="checkbox"/> <input type="checkbox"/> <input type="checkbox"/></p> <p>1503 hydraulic lines <input type="checkbox"/> <input type="checkbox"/> <input type="checkbox"/> <input type="checkbox"/> <input type="checkbox"/></p> <p>1504 hand operating-(function) <input type="checkbox"/> <input type="checkbox"/> <input type="checkbox"/> <input type="checkbox"/> <input type="checkbox"/></p> <p>1505 boom control valve <input type="checkbox"/> <input type="checkbox"/> <input type="checkbox"/> <input type="checkbox"/> <input type="checkbox"/></p> <p>1506 hydraulic pump <input type="checkbox"/> <input type="checkbox"/> <input type="checkbox"/> <input type="checkbox"/> <input type="checkbox"/></p> <p>1600 electric equipment</p> <p>1601 remote control (functions) <input type="checkbox"/> <input type="checkbox"/> <input type="checkbox"/> <input type="checkbox"/> <input type="checkbox"/></p> <p>1602 emergency stop (function) <input type="checkbox"/> <input type="checkbox"/> <input type="checkbox"/> <input type="checkbox"/> <input type="checkbox"/></p> <p>1603 switch for outrigger function <input type="checkbox"/> <input type="checkbox"/> <input type="checkbox"/> <input type="checkbox"/> <input type="checkbox"/></p> <p>1604 switch for boom function <input type="checkbox"/> <input type="checkbox"/> <input type="checkbox"/> <input type="checkbox"/> <input type="checkbox"/></p> <p>1605 wiring harness <input type="checkbox"/> <input type="checkbox"/> <input type="checkbox"/> <input type="checkbox"/> <input type="checkbox"/></p> <p>1606 central lubrication <input type="checkbox"/> <input type="checkbox"/> <input type="checkbox"/> <input type="checkbox"/> <input type="checkbox"/></p>	<p>1700 sticker sets</p> <p>1701 safety hints <input type="checkbox"/> <input type="checkbox"/> <input type="checkbox"/> <input type="checkbox"/> <input type="checkbox"/></p> <p>1702 description <input type="checkbox"/> <input type="checkbox"/> <input type="checkbox"/> <input type="checkbox"/> <input type="checkbox"/></p> <p>1703 operating <input type="checkbox"/> <input type="checkbox"/> <input type="checkbox"/> <input type="checkbox"/> <input type="checkbox"/></p> <p>1704 short operating instruction <input type="checkbox"/> <input type="checkbox"/> <input type="checkbox"/> <input type="checkbox"/> <input type="checkbox"/></p> <p>1705 sticker „don't use the boom as crane" <input type="checkbox"/> <input type="checkbox"/> <input type="checkbox"/> <input type="checkbox"/> <input type="checkbox"/></p> <p>1706 sticker „guideline operating with boom- and concrete pump" <input type="checkbox"/> <input type="checkbox"/> <input type="checkbox"/> <input type="checkbox"/> <input type="checkbox"/></p> <p>1707 name plate <input type="checkbox"/> <input type="checkbox"/> <input type="checkbox"/> <input type="checkbox"/> <input type="checkbox"/></p> <p>1708 sticker „danger high voltage" <input type="checkbox"/> <input type="checkbox"/> <input type="checkbox"/> <input type="checkbox"/> <input type="checkbox"/></p> <p>Competent inspector:</p> <p>Date: _____</p> <p>Name: _____</p> <p>Signature: _____ (stamp)</p> <p>Customer:</p> <p>Signature: _____ (stamp)</p>
--	---

Inspection report for concrete pump

Inspection report Nr:	Machine-Nr:	Hours of operation:
		Concrete output m³:
Company:	Post code:	City:

NL	WV
----	----

Proof – Result of the tests

without defects	defects	reinspection required	shut down
<input type="checkbox"/>	<input type="checkbox"/>	<input type="checkbox"/>	<input type="checkbox"/>

Reinspection until date:

Error code:

- | | | | |
|------------------|---------------------|-------------------|--------------------------|
| 00 no objections | 08 corrosion | 16 porous | 24 deformation |
| 01 cracks | 09 lacquer failures | 17 burned through | 25 bear movement |
| 02 broken | 10 fraying | 18 not fixed | 26 lubrication |
| 03 leaky | 11 scratched | 19 clomp | 27 readability |
| 04 no fuction | 12 bendet | 20 sawing | 28 missing components |
| 05 low livetime | 13 noises | 21 contaminated | 29 hydraulic |
| 06 worn out | 14 vibration | 22 bad contact | 30 electrical |
| 07 dirt | 15 miscellaneous | 23 temperature | 31 reinspection required |

2000 documents

2001 operating manual

2002 spare parts list

2100 drive assembly

2101 coupling and flange

2200 gear box

2300 hydraulic pump (main)

2400 oil-tank

2500 drive shaft

2700 hydraulic control system

2701 pressure relief valve

2702 pressure setting

2703 hydraulic line

2704 mechanical operation by hand

2800 oil –cooler

2900 accumulator

2901 proofs of the required tests according to accumulator regulation

2902 pressure gauge

Notes:

Inspection report for concrete pump

Page 2-3

Inspection report Nr: _____ Machine-Nr: _____

Error code:

- | | | | |
|------------------|---------------------|-------------------|--------------------------|
| 00 no objections | 08 corrosion | 16 porous | 24 deformation |
| 01 cracks | 09 lacquer failures | 17 burned through | 25 bear movement |
| 02 broken | 10 fraying | 18 not fixed | 26 lubrication |
| 03 leaky | 11 scratched | 19 clemp | 27 readability |
| 04 no function | 12 bendet | 20 sawing | 28 missing components |
| 05 low lifetime | 13 noises | 21 contaminated | 29 hydraulical |
| 06 worn out | 14 vibration | 22 bad contact | 30 electrical |
| 07 dirt | 15 miscellaneous | 23 temperature | 31 reinspection required |

- | | |
|---------------------------------|--|
| 3000 central lubrication | <input type="checkbox"/> <input type="checkbox"/> <input type="checkbox"/> <input type="checkbox"/> <input type="checkbox"/> |
| 3100 hydraulic motor | <input type="checkbox"/> <input type="checkbox"/> <input type="checkbox"/> <input type="checkbox"/> <input type="checkbox"/> |
| 3200 hydraulic lines | <input type="checkbox"/> <input type="checkbox"/> <input type="checkbox"/> <input type="checkbox"/> <input type="checkbox"/> |
| 3300 air compressor | <input type="checkbox"/> <input type="checkbox"/> <input type="checkbox"/> <input type="checkbox"/> <input type="checkbox"/> |
| 3400 control panel | <input type="checkbox"/> <input type="checkbox"/> <input type="checkbox"/> <input type="checkbox"/> <input type="checkbox"/> |
| 3500 concrete pump | <input type="checkbox"/> <input type="checkbox"/> <input type="checkbox"/> <input type="checkbox"/> <input type="checkbox"/> |
| 3700 S-valve | <input type="checkbox"/> <input type="checkbox"/> <input type="checkbox"/> <input type="checkbox"/> <input type="checkbox"/> |
| 3800 hopper | <input type="checkbox"/> <input type="checkbox"/> <input type="checkbox"/> <input type="checkbox"/> <input type="checkbox"/> |
| 4100 sub frame | <input type="checkbox"/> <input type="checkbox"/> <input type="checkbox"/> <input type="checkbox"/> <input type="checkbox"/> |
| 4200 water tank | <input type="checkbox"/> <input type="checkbox"/> <input type="checkbox"/> <input type="checkbox"/> <input type="checkbox"/> |
| 4300 axle | <input type="checkbox"/> <input type="checkbox"/> <input type="checkbox"/> <input type="checkbox"/> <input type="checkbox"/> |
| 4400 water pump | <input type="checkbox"/> <input type="checkbox"/> <input type="checkbox"/> <input type="checkbox"/> <input type="checkbox"/> |
| 4500 vibrator | <input type="checkbox"/> <input type="checkbox"/> <input type="checkbox"/> <input type="checkbox"/> <input type="checkbox"/> |

4600 safety guards, equipment

- | | |
|--|--|
| 4601 stair | <input type="checkbox"/> <input type="checkbox"/> <input type="checkbox"/> <input type="checkbox"/> <input type="checkbox"/> |
| 4602 safety for stair | <input type="checkbox"/> <input type="checkbox"/> <input type="checkbox"/> <input type="checkbox"/> <input type="checkbox"/> |
| 4603 handrail | <input type="checkbox"/> <input type="checkbox"/> <input type="checkbox"/> <input type="checkbox"/> <input type="checkbox"/> |
| 4604 hopper grid
(fixing device) | <input type="checkbox"/> <input type="checkbox"/> <input type="checkbox"/> <input type="checkbox"/> <input type="checkbox"/> |
| 4606 distance of grid rods | <input type="checkbox"/> <input type="checkbox"/> <input type="checkbox"/> <input type="checkbox"/> <input type="checkbox"/> |
| 4607 distance from grid to
agitator | <input type="checkbox"/> <input type="checkbox"/> <input type="checkbox"/> <input type="checkbox"/> <input type="checkbox"/> |
| 4609 agitator have to stop
if grid is open | <input type="checkbox"/> <input type="checkbox"/> <input type="checkbox"/> <input type="checkbox"/> <input type="checkbox"/> |
| 4610 accumulator have to
dump if grid is open | <input type="checkbox"/> <input type="checkbox"/> <input type="checkbox"/> <input type="checkbox"/> <input type="checkbox"/> |
| 4612 cleaning flap hopper | <input type="checkbox"/> <input type="checkbox"/> <input type="checkbox"/> <input type="checkbox"/> <input type="checkbox"/> |
| 4613 safety grid into water
box | <input type="checkbox"/> <input type="checkbox"/> <input type="checkbox"/> <input type="checkbox"/> <input type="checkbox"/> |

Notes:

Inspection report for concrete pump

Inspection report Nr: _____

Machine-Nr: _____

Error code:

00 no objections	08 corrosion	16 porous	24 deformation
01 cracks	09 lacquer failures	17 burned through	25 bear movement
02 broken	10 fraying	18 not fixed	26 lubrication
03 leaky	11 scratched	19 clomp	27 readability
04 no function	12 bendet	20 sawing	28 missing components
05 low lifetime	13 noises	21 contaminated	29 hydraulical
06 worn out	14 vibration	22 bad contact	30 electrical
07 dirt	15 miscellaneous	23 temperature	31 reinspection required

4614 cover for rotating wave

4616 cover for chains

4617 cover for shift cylinder

4618 cover for moving parts

4619 cover for the exhaust pipe

4700 electrical system

4701 function of actuator component

4702 emergency stop function

4703 ground connections

4704 cables and wiring harness

4705 temperature switch

4800 outrigger - system

4801 transportation lock

4802 locking device

4803 backing plate

4804 jack cylinder connections

4805 pressure adjustment of jack cylinder

4900 miscellaneous

4901 additional assembled part from operator

4902 changes through operator

Competent inspector:

Date:

Name:

Signature:
(stamp)

Customer:

Signature:
(stamp)

This test report is filed into the test book

Inspection report for concrete booms

Inspection report -Nr:	Machine-Nr:	Hours of operation:
		Concrete output m³:
Company:	Post code:	City:
Boom Type:	Boom Nr.:	NL WV

Proof – Result of the Tests

without defects	defects	reinspection required	shut down
<input type="checkbox"/>	<input type="checkbox"/>	<input type="checkbox"/>	<input type="checkbox"/>

Reinspection until date:

Error code:

- | | | | |
|------------------|---------------------|-------------------|--------------------------|
| 00 no objections | 08 corrosion | 16 porous | 24 deformation |
| 01 cracks | 09 lacquer failures | 17 burned through | 25 bear movement |
| 02 broken | 10 fraying | 18 not fixed | 26 lubrication |
| 03 leaky | 11 scratched | 19 clomp | 27 readability |
| 04 no function | 12 bendet | 20 sawing | 28 missing components |
| 05 low lifetime | 13 noises | 21 contaminated | 29 hydraulic |
| 06 worn out | 14 vibration | 22 bad contact | 30 electrical |
| 07 dirt | 15 miscellaneous | 23 temperature | 31 reinspection required |

100 documents

101 instruction manual	<input type="checkbox"/>	<input type="checkbox"/>	<input type="checkbox"/>	<input type="checkbox"/>
102 spare parts list	<input type="checkbox"/>	<input type="checkbox"/>	<input type="checkbox"/>	<input type="checkbox"/>

200 sub frame

201 frame connection cpl.	<input type="checkbox"/>	<input type="checkbox"/>	<input type="checkbox"/>	<input type="checkbox"/>
---------------------------	--------------------------	--------------------------	--------------------------	--------------------------

300 outrigger front R+L

301 transportation safety device	<input type="checkbox"/>	<input type="checkbox"/>	<input type="checkbox"/>	<input type="checkbox"/>
302 outrigger	<input type="checkbox"/>	<input type="checkbox"/>	<input type="checkbox"/>	<input type="checkbox"/>
303 extension box	<input type="checkbox"/>	<input type="checkbox"/>	<input type="checkbox"/>	<input type="checkbox"/>
304 locking device	<input type="checkbox"/>	<input type="checkbox"/>	<input type="checkbox"/>	<input type="checkbox"/>
305 slewing bearing	<input type="checkbox"/>	<input type="checkbox"/>	<input type="checkbox"/>	<input type="checkbox"/>
306 turn locking device	<input type="checkbox"/>	<input type="checkbox"/>	<input type="checkbox"/>	<input type="checkbox"/>
307 support safeguard	<input type="checkbox"/>	<input type="checkbox"/>	<input type="checkbox"/>	<input type="checkbox"/>
308 support plate	<input type="checkbox"/>	<input type="checkbox"/>	<input type="checkbox"/>	<input type="checkbox"/>
309 fixing of jack cylinder	<input type="checkbox"/>	<input type="checkbox"/>	<input type="checkbox"/>	<input type="checkbox"/>
310 jack cylinder	<input type="checkbox"/>	<input type="checkbox"/>	<input type="checkbox"/>	<input type="checkbox"/>

311 swing cylinder	<input type="checkbox"/>	<input type="checkbox"/>	<input type="checkbox"/>	<input type="checkbox"/>
--------------------	--------------------------	--------------------------	--------------------------	--------------------------

312 telescopic-cylinder	<input type="checkbox"/>	<input type="checkbox"/>	<input type="checkbox"/>	<input type="checkbox"/>
-------------------------	--------------------------	--------------------------	--------------------------	--------------------------

313 pressure adjustment	<input type="checkbox"/>	<input type="checkbox"/>	<input type="checkbox"/>	<input type="checkbox"/>
-------------------------	--------------------------	--------------------------	--------------------------	--------------------------

400 outrigger rear L+R

401 transportation safety device	<input type="checkbox"/>	<input type="checkbox"/>	<input type="checkbox"/>	<input type="checkbox"/>
402 outrigger	<input type="checkbox"/>	<input type="checkbox"/>	<input type="checkbox"/>	<input type="checkbox"/>
403 extension box	<input type="checkbox"/>	<input type="checkbox"/>	<input type="checkbox"/>	<input type="checkbox"/>
405 locking device	<input type="checkbox"/>	<input type="checkbox"/>	<input type="checkbox"/>	<input type="checkbox"/>

Notes:

Inspection report for concrete booms

Inspection report Nr: _____ Boom type: _____ Machine-Nr: _____

- Error code:**
- | | | | |
|------------------|---------------------|-------------------|--------------------------|
| 00 no objections | 08 corrosion | 16 porous | 24 deformation |
| 01 cracks | 09 lacquer failures | 17 burned through | 25 bear movement |
| 02 broken | 10 fraying | 18 not fixed | 26 lubrication |
| 03 leaky | 11 scratched | 19 clemp | 27 readability |
| 04 no function | 12 bendet | 20 sawing | 28 missing components |
| 05 low lifetime | 13 noises | 21 contaminated | 29 hydraulical |
| 06 worn out | 14 vibration | 22 bad contact | 30 electrical |
| 07 dirt | 15 miscellaneous | 23 temperature | 31 reinspection required |

<p>406 slewing bearing <input type="checkbox"/> <input type="checkbox"/> <input type="checkbox"/> <input type="checkbox"/> <input type="checkbox"/></p> <p>407 turn locking device <input type="checkbox"/> <input type="checkbox"/> <input type="checkbox"/> <input type="checkbox"/> <input type="checkbox"/></p> <p>408 support safeguard <input type="checkbox"/> <input type="checkbox"/> <input type="checkbox"/> <input type="checkbox"/> <input type="checkbox"/></p> <p>409 support plate <input type="checkbox"/> <input type="checkbox"/> <input type="checkbox"/> <input type="checkbox"/> <input type="checkbox"/></p> <p>410 fixing of jack cylinder <input type="checkbox"/> <input type="checkbox"/> <input type="checkbox"/> <input type="checkbox"/> <input type="checkbox"/></p> <p>411 jack cylinder <input type="checkbox"/> <input type="checkbox"/> <input type="checkbox"/> <input type="checkbox"/> <input type="checkbox"/></p> <p>412 swing cylinder <input type="checkbox"/> <input type="checkbox"/> <input type="checkbox"/> <input type="checkbox"/> <input type="checkbox"/></p> <p>413 telescopic cylinder <input type="checkbox"/> <input type="checkbox"/> <input type="checkbox"/> <input type="checkbox"/> <input type="checkbox"/></p> <p>500 pedestal</p> <p>501 pedestal mounting <input type="checkbox"/> <input type="checkbox"/> <input type="checkbox"/> <input type="checkbox"/> <input type="checkbox"/></p> <p>502 sub frame <input type="checkbox"/> <input type="checkbox"/> <input type="checkbox"/> <input type="checkbox"/> <input type="checkbox"/></p> <p>503 truck frame <input type="checkbox"/> <input type="checkbox"/> <input type="checkbox"/> <input type="checkbox"/> <input type="checkbox"/></p> <p>504 pedestal (structure) <input type="checkbox"/> <input type="checkbox"/> <input type="checkbox"/> <input type="checkbox"/> <input type="checkbox"/></p> <p>505 boom valve without leaking <input type="checkbox"/> <input type="checkbox"/> <input type="checkbox"/> <input type="checkbox"/> <input type="checkbox"/></p> <p>506 boom rest <input type="checkbox"/> <input type="checkbox"/> <input type="checkbox"/> <input type="checkbox"/> <input type="checkbox"/></p> <p>507 transportation safety device <input type="checkbox"/> <input type="checkbox"/> <input type="checkbox"/> <input type="checkbox"/> <input type="checkbox"/></p> <p>508 hydraulic line <input type="checkbox"/> <input type="checkbox"/> <input type="checkbox"/> <input type="checkbox"/> <input type="checkbox"/></p> <p>600 slewing head with ball pivot</p> <p>601 slewing head <input type="checkbox"/> <input type="checkbox"/> <input type="checkbox"/> <input type="checkbox"/> <input type="checkbox"/></p> <p>602 ball pivot ring <input type="checkbox"/> <input type="checkbox"/> <input type="checkbox"/> <input type="checkbox"/> <input type="checkbox"/></p> <p>603 mounting ball pivot ring <input type="checkbox"/> <input type="checkbox"/> <input type="checkbox"/> <input type="checkbox"/> <input type="checkbox"/></p> <p>604 drive pinion <input type="checkbox"/> <input type="checkbox"/> <input type="checkbox"/> <input type="checkbox"/> <input type="checkbox"/></p>	<p>605 slewing drive mounting <input type="checkbox"/> <input type="checkbox"/> <input type="checkbox"/> <input type="checkbox"/> <input type="checkbox"/></p> <p>606 slewing stop device <input type="checkbox"/> <input type="checkbox"/> <input type="checkbox"/> <input type="checkbox"/> <input type="checkbox"/></p> <p>607 slewing drive (tooth backlash) <input type="checkbox"/> <input type="checkbox"/> <input type="checkbox"/> <input type="checkbox"/> <input type="checkbox"/></p> <p>608 slewing drive <input type="checkbox"/> <input type="checkbox"/> <input type="checkbox"/> <input type="checkbox"/> <input type="checkbox"/></p> <p>609 brake function <input type="checkbox"/> <input type="checkbox"/> <input type="checkbox"/> <input type="checkbox"/> <input type="checkbox"/></p> <p>610 speed <input type="checkbox"/> <input type="checkbox"/> <input type="checkbox"/> <input type="checkbox"/> <input type="checkbox"/></p> <p>611 pressure setting <input type="checkbox"/> <input type="checkbox"/> <input type="checkbox"/> <input type="checkbox"/> <input type="checkbox"/></p> <p>612 hydraulic lines <input type="checkbox"/> <input type="checkbox"/> <input type="checkbox"/> <input type="checkbox"/> <input type="checkbox"/></p> <p>700 slewing head with slewing column</p> <p>701 slewing head <input type="checkbox"/> <input type="checkbox"/> <input type="checkbox"/> <input type="checkbox"/> <input type="checkbox"/></p> <p>702 slewing column bearing <input type="checkbox"/> <input type="checkbox"/> <input type="checkbox"/> <input type="checkbox"/> <input type="checkbox"/></p> <p>703 slewing drive (tooth backlash) <input type="checkbox"/> <input type="checkbox"/> <input type="checkbox"/> <input type="checkbox"/> <input type="checkbox"/></p> <p>704 speed <input type="checkbox"/> <input type="checkbox"/> <input type="checkbox"/> <input type="checkbox"/> <input type="checkbox"/></p> <p>705 pressure settings <input type="checkbox"/> <input type="checkbox"/> <input type="checkbox"/> <input type="checkbox"/> <input type="checkbox"/></p> <p>706 hydraulic lines <input type="checkbox"/> <input type="checkbox"/> <input type="checkbox"/> <input type="checkbox"/> <input type="checkbox"/></p> <p>707 swivel cylinder <input type="checkbox"/> <input type="checkbox"/> <input type="checkbox"/> <input type="checkbox"/> <input type="checkbox"/></p> <p>Notes:</p> <hr/> <hr/> <hr/> <hr/>
---	---

Inspection report for concrete booms

Inspection report Nr: _____ Boom type: _____ Machine-Nr: _____

Error code:			
00 no objections	08 corrosion	16 porous	24 deformation
01 cracks	09 lacquer failures	17 burned through	25 bear movement
02 broken	10 fraying	18 not fixed	26 lubrication
03 leaky	11 scratched	19 clomp	27 readability
04 no function	12 bendet	20 sawing	28 missing components
05 low lifetime	13 noises	21 contaminated	29 hydraulical
06 worn out	14 vibration	22 bad contact	30 electrical
07 dirt	15 miscellaneous	23 temperature	31 reinspection required

<p>800 boom</p> <p>801 „Arm 1“ <input type="checkbox"/> <input type="checkbox"/> <input type="checkbox"/> <input type="checkbox"/> <input type="checkbox"/></p> <p>802 bracket conveying line <input type="checkbox"/> <input type="checkbox"/> <input type="checkbox"/> <input type="checkbox"/> <input type="checkbox"/></p> <p>803 Drop hook <input type="checkbox"/> <input type="checkbox"/> <input type="checkbox"/> <input type="checkbox"/> <input type="checkbox"/></p> <p>804 „Arm 2“ <input type="checkbox"/> <input type="checkbox"/> <input type="checkbox"/> <input type="checkbox"/> <input type="checkbox"/></p> <p>805 bracket conveying line <input type="checkbox"/> <input type="checkbox"/> <input type="checkbox"/> <input type="checkbox"/> <input type="checkbox"/></p> <p>806 Drop hook <input type="checkbox"/> <input type="checkbox"/> <input type="checkbox"/> <input type="checkbox"/> <input type="checkbox"/></p> <p>807 „Arm 3“ <input type="checkbox"/> <input type="checkbox"/> <input type="checkbox"/> <input type="checkbox"/> <input type="checkbox"/></p> <p>808 bracket conveying line <input type="checkbox"/> <input type="checkbox"/> <input type="checkbox"/> <input type="checkbox"/> <input type="checkbox"/></p> <p>809 guidance and interlock of the arm <input type="checkbox"/> <input type="checkbox"/> <input type="checkbox"/> <input type="checkbox"/> <input type="checkbox"/></p> <p>810 „Arm 4“ <input type="checkbox"/> <input type="checkbox"/> <input type="checkbox"/> <input type="checkbox"/> <input type="checkbox"/></p> <p>811 bracket conveying line <input type="checkbox"/> <input type="checkbox"/> <input type="checkbox"/> <input type="checkbox"/> <input type="checkbox"/></p> <p>812 guidance and interlock of the arm <input type="checkbox"/> <input type="checkbox"/> <input type="checkbox"/> <input type="checkbox"/> <input type="checkbox"/></p> <p>813 „Arm 5“ <input type="checkbox"/> <input type="checkbox"/> <input type="checkbox"/> <input type="checkbox"/> <input type="checkbox"/></p> <p>814 bracket conveying line <input type="checkbox"/> <input type="checkbox"/> <input type="checkbox"/> <input type="checkbox"/> <input type="checkbox"/></p> <p>815 guidance and interlock of the arm <input type="checkbox"/> <input type="checkbox"/> <input type="checkbox"/> <input type="checkbox"/> <input type="checkbox"/></p> <p>900 joint „A“</p> <p>901 boom <input type="checkbox"/> <input type="checkbox"/> <input type="checkbox"/> <input type="checkbox"/> <input type="checkbox"/></p> <p>902 link lever <input type="checkbox"/> <input type="checkbox"/> <input type="checkbox"/> <input type="checkbox"/> <input type="checkbox"/></p> <p>903 forcing rod <input type="checkbox"/> <input type="checkbox"/> <input type="checkbox"/> <input type="checkbox"/> <input type="checkbox"/></p> <p>904 pin <input type="checkbox"/> <input type="checkbox"/> <input type="checkbox"/> <input type="checkbox"/> <input type="checkbox"/></p> <p>905 cylinder <input type="checkbox"/> <input type="checkbox"/> <input type="checkbox"/> <input type="checkbox"/> <input type="checkbox"/></p>	<p>906 boom speed <input type="checkbox"/> <input type="checkbox"/> <input type="checkbox"/> <input type="checkbox"/> <input type="checkbox"/></p> <p>907 pressure settings <input type="checkbox"/> <input type="checkbox"/> <input type="checkbox"/> <input type="checkbox"/> <input type="checkbox"/></p> <p>908 hydraulic lines <input type="checkbox"/> <input type="checkbox"/> <input type="checkbox"/> <input type="checkbox"/> <input type="checkbox"/></p> <p>909 load holding valve (piston side) <input type="checkbox"/> <input type="checkbox"/> <input type="checkbox"/> <input type="checkbox"/> <input type="checkbox"/></p> <p>910 load holding valve (rod side) <input type="checkbox"/> <input type="checkbox"/> <input type="checkbox"/> <input type="checkbox"/> <input type="checkbox"/></p> <p>1000 joint „B“</p> <p>1001 boom <input type="checkbox"/> <input type="checkbox"/> <input type="checkbox"/> <input type="checkbox"/> <input type="checkbox"/></p> <p>1002 link lever <input type="checkbox"/> <input type="checkbox"/> <input type="checkbox"/> <input type="checkbox"/> <input type="checkbox"/></p> <p>1003 forcing rod <input type="checkbox"/> <input type="checkbox"/> <input type="checkbox"/> <input type="checkbox"/> <input type="checkbox"/></p> <p>1004 pin <input type="checkbox"/> <input type="checkbox"/> <input type="checkbox"/> <input type="checkbox"/> <input type="checkbox"/></p> <p>1005 cylinder <input type="checkbox"/> <input type="checkbox"/> <input type="checkbox"/> <input type="checkbox"/> <input type="checkbox"/></p> <p>1006 boom speed <input type="checkbox"/> <input type="checkbox"/> <input type="checkbox"/> <input type="checkbox"/> <input type="checkbox"/></p> <p>1007 pressure settings <input type="checkbox"/> <input type="checkbox"/> <input type="checkbox"/> <input type="checkbox"/> <input type="checkbox"/></p> <p>1008 hydraulic lines <input type="checkbox"/> <input type="checkbox"/> <input type="checkbox"/> <input type="checkbox"/> <input type="checkbox"/></p> <p>1009 load holding valve (piston side) <input type="checkbox"/> <input type="checkbox"/> <input type="checkbox"/> <input type="checkbox"/> <input type="checkbox"/></p> <p>1010 load holding valve (rod side) <input type="checkbox"/> <input type="checkbox"/> <input type="checkbox"/> <input type="checkbox"/> <input type="checkbox"/></p> <p>Notes:</p> <hr/> <hr/> <hr/> <hr/>
--	---

Inspection report for concrete booms

Inspection report Nr: _____ Boom type: _____ Machine-Nr: _____

- | | | | |
|------------------|---------------------|-------------------|--------------------------|
| Error code: | | | |
| 00 no objections | 08 corrosion | 16 porous | 24 deformation |
| 01 cracks | 09 lacquer failures | 17 burned through | 25 bear movement |
| 02 broken | 10 fraying | 18 not fixed | 26 lubrication |
| 03 leaky | 11 scratched | 19 clemp | 27 readability |
| 04 no function | 12 bendet | 20 sawing | 28 missing components |
| 05 low lifetime | 13 noises | 21 contaminated | 29 hydraulical |
| 06 worn out | 14 vibration | 22 bad contact | 30 electrical |
| 07 dirt | 15 miscellaneous | 23 temperature | 31 reinspection required |

1100 joint "C"

- | | | | | | |
|--|--------------------------|--------------------------|--------------------------|--------------------------|--------------------------|
| 1101 boom | <input type="checkbox"/> | <input type="checkbox"/> | <input type="checkbox"/> | <input type="checkbox"/> | <input type="checkbox"/> |
| 1102 link lever | <input type="checkbox"/> | <input type="checkbox"/> | <input type="checkbox"/> | <input type="checkbox"/> | <input type="checkbox"/> |
| 1103 forcing rod | <input type="checkbox"/> | <input type="checkbox"/> | <input type="checkbox"/> | <input type="checkbox"/> | <input type="checkbox"/> |
| 1104 pin | <input type="checkbox"/> | <input type="checkbox"/> | <input type="checkbox"/> | <input type="checkbox"/> | <input type="checkbox"/> |
| 1105 cylinder | <input type="checkbox"/> | <input type="checkbox"/> | <input type="checkbox"/> | <input type="checkbox"/> | <input type="checkbox"/> |
| 1106 boom speed | <input type="checkbox"/> | <input type="checkbox"/> | <input type="checkbox"/> | <input type="checkbox"/> | <input type="checkbox"/> |
| 1107 pressure settings | <input type="checkbox"/> | <input type="checkbox"/> | <input type="checkbox"/> | <input type="checkbox"/> | <input type="checkbox"/> |
| 1108 hydraulic lines | <input type="checkbox"/> | <input type="checkbox"/> | <input type="checkbox"/> | <input type="checkbox"/> | <input type="checkbox"/> |
| 1109 load holding valve
(piston side) | <input type="checkbox"/> | <input type="checkbox"/> | <input type="checkbox"/> | <input type="checkbox"/> | <input type="checkbox"/> |
| 1110 load holding valve
(rod side) | <input type="checkbox"/> | <input type="checkbox"/> | <input type="checkbox"/> | <input type="checkbox"/> | <input type="checkbox"/> |

1200 joint "D"

- | | | | | | |
|--|--------------------------|--------------------------|--------------------------|--------------------------|--------------------------|
| 1201 boom | <input type="checkbox"/> | <input type="checkbox"/> | <input type="checkbox"/> | <input type="checkbox"/> | <input type="checkbox"/> |
| 1202 link lever | <input type="checkbox"/> | <input type="checkbox"/> | <input type="checkbox"/> | <input type="checkbox"/> | <input type="checkbox"/> |
| 1203 forcing rod | <input type="checkbox"/> | <input type="checkbox"/> | <input type="checkbox"/> | <input type="checkbox"/> | <input type="checkbox"/> |
| 1204 pin | <input type="checkbox"/> | <input type="checkbox"/> | <input type="checkbox"/> | <input type="checkbox"/> | <input type="checkbox"/> |
| 1205 cylinder | <input type="checkbox"/> | <input type="checkbox"/> | <input type="checkbox"/> | <input type="checkbox"/> | <input type="checkbox"/> |
| 1206 boom speed | <input type="checkbox"/> | <input type="checkbox"/> | <input type="checkbox"/> | <input type="checkbox"/> | <input type="checkbox"/> |
| 1207 pressure settings | <input type="checkbox"/> | <input type="checkbox"/> | <input type="checkbox"/> | <input type="checkbox"/> | <input type="checkbox"/> |
| 1208 hydraulic lines | <input type="checkbox"/> | <input type="checkbox"/> | <input type="checkbox"/> | <input type="checkbox"/> | <input type="checkbox"/> |
| 1209 load holding valve
(piston side) | <input type="checkbox"/> | <input type="checkbox"/> | <input type="checkbox"/> | <input type="checkbox"/> | <input type="checkbox"/> |
| 1210 load holding valve
(rod side) | <input type="checkbox"/> | <input type="checkbox"/> | <input type="checkbox"/> | <input type="checkbox"/> | <input type="checkbox"/> |

1300 joint „E“

- | | | | | | |
|--|--------------------------|--------------------------|--------------------------|--------------------------|--------------------------|
| 1301 boom | <input type="checkbox"/> | <input type="checkbox"/> | <input type="checkbox"/> | <input type="checkbox"/> | <input type="checkbox"/> |
| 1302 link lever | <input type="checkbox"/> | <input type="checkbox"/> | <input type="checkbox"/> | <input type="checkbox"/> | <input type="checkbox"/> |
| 1303 forcing rod | <input type="checkbox"/> | <input type="checkbox"/> | <input type="checkbox"/> | <input type="checkbox"/> | <input type="checkbox"/> |
| 1304 pin | <input type="checkbox"/> | <input type="checkbox"/> | <input type="checkbox"/> | <input type="checkbox"/> | <input type="checkbox"/> |
| 1305 cylinder | <input type="checkbox"/> | <input type="checkbox"/> | <input type="checkbox"/> | <input type="checkbox"/> | <input type="checkbox"/> |
| 1306 boom speed | <input type="checkbox"/> | <input type="checkbox"/> | <input type="checkbox"/> | <input type="checkbox"/> | <input type="checkbox"/> |
| 1307 pressure settings | <input type="checkbox"/> | <input type="checkbox"/> | <input type="checkbox"/> | <input type="checkbox"/> | <input type="checkbox"/> |
| 1308 hydraulic lines | <input type="checkbox"/> | <input type="checkbox"/> | <input type="checkbox"/> | <input type="checkbox"/> | <input type="checkbox"/> |
| 1309 load holding valve
(piston side) | <input type="checkbox"/> | <input type="checkbox"/> | <input type="checkbox"/> | <input type="checkbox"/> | <input type="checkbox"/> |
| 1310 load holding valve
(rod side) | <input type="checkbox"/> | <input type="checkbox"/> | <input type="checkbox"/> | <input type="checkbox"/> | <input type="checkbox"/> |

1400 concrete delivery line

- | | | | | | |
|--|--------------------------|--------------------------|--------------------------|--------------------------|--------------------------|
| 1401 assembly of delivery
line DN | <input type="checkbox"/> | <input type="checkbox"/> | <input type="checkbox"/> | <input type="checkbox"/> | <input type="checkbox"/> |
| 1402 end hose
DN+lenght | <input type="checkbox"/> | <input type="checkbox"/> | <input type="checkbox"/> | <input type="checkbox"/> | <input type="checkbox"/> |
| 1403 delivery line
DN | <input type="checkbox"/> | <input type="checkbox"/> | <input type="checkbox"/> | <input type="checkbox"/> | <input type="checkbox"/> |
| 1404 rotating joints of -
delivery line | <input type="checkbox"/> | <input type="checkbox"/> | <input type="checkbox"/> | <input type="checkbox"/> | <input type="checkbox"/> |
| 1405 locking pin of the
coupling | <input type="checkbox"/> | <input type="checkbox"/> | <input type="checkbox"/> | <input type="checkbox"/> | <input type="checkbox"/> |

Notes:

--	--

Inspection report for concrete booms

Inspection report Nr: _____ Boom type: _____ Machine-Nr: _____

Error code:

00 no objections	08 corrosion	16 porous	24 deformation
01 cracks	09 lacquer failures	17 burned through	25 bear movement
02 broken	10 fraying	18 not fixed	26 lubrication
03 leaky	11 scratched	19 clemp	27 readability
04 no function	12 bendet	20 sawing	28 missing components
05 low lifetime	13 noises	21 contamitated	29 hydraulical
06 worn out	14 vibration	22 bad contact	30 electrical
07 dirt	15 miscellaneous	23 temperature	31 reinspection required

<p>1406 end hose safety device <input type="checkbox"/> <input type="checkbox"/> <input type="checkbox"/> <input type="checkbox"/> <input type="checkbox"/></p> <p>1407 reducer <input type="checkbox"/> <input type="checkbox"/> <input type="checkbox"/> <input type="checkbox"/> <input type="checkbox"/></p> <p>1408 gate elbow, elbow 6" <input type="checkbox"/> <input type="checkbox"/> <input type="checkbox"/> <input type="checkbox"/> <input type="checkbox"/></p> <p>1500 hydraulic system and hydraulic valves</p> <p>1501 Pressure relief valve <input type="checkbox"/> <input type="checkbox"/> <input type="checkbox"/> <input type="checkbox"/> <input type="checkbox"/></p> <p>1502 pressure settings <input type="checkbox"/> <input type="checkbox"/> <input type="checkbox"/> <input type="checkbox"/> <input type="checkbox"/></p> <p>1503 hydraulic lines <input type="checkbox"/> <input type="checkbox"/> <input type="checkbox"/> <input type="checkbox"/> <input type="checkbox"/></p> <p>1504 hand operating-(function) <input type="checkbox"/> <input type="checkbox"/> <input type="checkbox"/> <input type="checkbox"/> <input type="checkbox"/></p> <p>1505 boom control valve <input type="checkbox"/> <input type="checkbox"/> <input type="checkbox"/> <input type="checkbox"/> <input type="checkbox"/></p> <p>1506 hydraulic pump <input type="checkbox"/> <input type="checkbox"/> <input type="checkbox"/> <input type="checkbox"/> <input type="checkbox"/></p> <p>1600 electric equipment</p> <p>1601 remote control (functions) <input type="checkbox"/> <input type="checkbox"/> <input type="checkbox"/> <input type="checkbox"/> <input type="checkbox"/></p> <p>1602 emergency stop (function) <input type="checkbox"/> <input type="checkbox"/> <input type="checkbox"/> <input type="checkbox"/> <input type="checkbox"/></p> <p>1603 switch for outrigger function <input type="checkbox"/> <input type="checkbox"/> <input type="checkbox"/> <input type="checkbox"/> <input type="checkbox"/></p> <p>1604 switch for boom function <input type="checkbox"/> <input type="checkbox"/> <input type="checkbox"/> <input type="checkbox"/> <input type="checkbox"/></p> <p>1605 wiring harness <input type="checkbox"/> <input type="checkbox"/> <input type="checkbox"/> <input type="checkbox"/> <input type="checkbox"/></p> <p>1606 central lubrication <input type="checkbox"/> <input type="checkbox"/> <input type="checkbox"/> <input type="checkbox"/> <input type="checkbox"/></p>	<p>1700 sticker sets</p> <p>1701 safety hints <input type="checkbox"/> <input type="checkbox"/> <input type="checkbox"/> <input type="checkbox"/> <input type="checkbox"/></p> <p>1702 description <input type="checkbox"/> <input type="checkbox"/> <input type="checkbox"/> <input type="checkbox"/> <input type="checkbox"/></p> <p>1703 operating <input type="checkbox"/> <input type="checkbox"/> <input type="checkbox"/> <input type="checkbox"/> <input type="checkbox"/></p> <p>1704 short operating instruction <input type="checkbox"/> <input type="checkbox"/> <input type="checkbox"/> <input type="checkbox"/> <input type="checkbox"/></p> <p>1705 sticker „ don't use the boom as crane“ <input type="checkbox"/> <input type="checkbox"/> <input type="checkbox"/> <input type="checkbox"/> <input type="checkbox"/></p> <p>1706 sticker „guideline operating with boom- and concrete pump“ <input type="checkbox"/> <input type="checkbox"/> <input type="checkbox"/> <input type="checkbox"/> <input type="checkbox"/></p> <p>1707 name plate <input type="checkbox"/> <input type="checkbox"/> <input type="checkbox"/> <input type="checkbox"/> <input type="checkbox"/></p> <p>1708 sticker „danger high voltage“ <input type="checkbox"/> <input type="checkbox"/> <input type="checkbox"/> <input type="checkbox"/> <input type="checkbox"/></p> <p>Competent inspector:</p> <p>Date: _____</p> <p>Name: _____</p> <p>Signature: _____ (stamp)</p> <p>Customer:</p> <p>Signature: _____ (stamp)</p>
--	--

Inspection report for concrete pump			Page 1-3
Inspection report Nr:	Machine-Nr:	Hours of operation:	
		Concrete output m³:	
Company:	Post code:	City:	
		NL	WV
Proof – Result of the tests			
without defects <input type="checkbox"/>	defects <input type="checkbox"/>	reinspection required <input type="checkbox"/>	shut down <input type="checkbox"/>
Reinspection until date:			
Error code:			
00 no objections	08 corrosion	16 porous	24 deformation
01 cracks	09 lacquer failures	17 burned through	25 bear movement
02 broken	10 fraying	18 not fixed	26 lubrication
03 leaky	11 scratched	19 clomp	27 readability
04 no fuction	12 bendet	20 sawing	28 missing components
05 low livetime	13 noises	21 contaminated	29 hydraulical
06 worn out	14 vibration	22 bad contact	30 electrical
07 dirt	15 miscellaneous	23 temperature	31 reinspection required
2000 documents		2700 hydraulic control system	
2001 operating manual	<input type="checkbox"/> <input type="checkbox"/> <input type="checkbox"/> <input type="checkbox"/> <input type="checkbox"/>	2701 pressure relief valve	<input type="checkbox"/> <input type="checkbox"/> <input type="checkbox"/> <input type="checkbox"/> <input type="checkbox"/>
2002 spare parts list	<input type="checkbox"/> <input type="checkbox"/> <input type="checkbox"/> <input type="checkbox"/> <input type="checkbox"/>	2702 pressure setting	<input type="checkbox"/> <input type="checkbox"/> <input type="checkbox"/> <input type="checkbox"/> <input type="checkbox"/>
2100 drive assembly		2703 hydraulic line	<input type="checkbox"/> <input type="checkbox"/> <input type="checkbox"/> <input type="checkbox"/> <input type="checkbox"/>
2101 coupling and flange	<input type="checkbox"/> <input type="checkbox"/> <input type="checkbox"/> <input type="checkbox"/> <input type="checkbox"/>	2704 mechanical operation by hand	<input type="checkbox"/> <input type="checkbox"/> <input type="checkbox"/> <input type="checkbox"/> <input type="checkbox"/>
2200 gear box		2800 oil –cooler	<input type="checkbox"/> <input type="checkbox"/> <input type="checkbox"/> <input type="checkbox"/> <input type="checkbox"/>
2200 gear box	<input type="checkbox"/> <input type="checkbox"/> <input type="checkbox"/> <input type="checkbox"/> <input type="checkbox"/>	2900 accumulator	<input type="checkbox"/> <input type="checkbox"/> <input type="checkbox"/> <input type="checkbox"/> <input type="checkbox"/>
2300 hydraulic pump (main)		2901 proofs of the required tests according to accumulator regulation	<input type="checkbox"/> <input type="checkbox"/> <input type="checkbox"/> <input type="checkbox"/> <input type="checkbox"/>
2300 hydraulic pump (main)	<input type="checkbox"/> <input type="checkbox"/> <input type="checkbox"/> <input type="checkbox"/> <input type="checkbox"/>	2902 pressure gauge	<input type="checkbox"/> <input type="checkbox"/> <input type="checkbox"/> <input type="checkbox"/> <input type="checkbox"/>
2400 oil-tank			
2400 oil-tank	<input type="checkbox"/> <input type="checkbox"/> <input type="checkbox"/> <input type="checkbox"/> <input type="checkbox"/>		
2500 drive shaft			
2500 drive shaft	<input type="checkbox"/> <input type="checkbox"/> <input type="checkbox"/> <input type="checkbox"/> <input type="checkbox"/>		
		Notes:	

Inspection report for concrete pump

Page 2-3

Inspection report Nr:

Machine-Nr:

Error code:

- | | | | |
|------------------|---------------------|-------------------|--------------------------|
| 00 no objections | 08 corrosion | 16 porous | 24 deformation |
| 01 cracks | 09 lacquer failures | 17 burned through | 25 bear movement |
| 02 broken | 10 fraying | 18 not fixed | 26 lubrication |
| 03 leaky | 11 scratched | 19 clemp | 27 readability |
| 04 no function | 12 bendet | 20 sawing | 28 missing components |
| 05 low lifetime | 13 noises | 21 contaminated | 29 hydraulical |
| 06 worn out | 14 vibration | 22 bad contact | 30 electrical |
| 07 dirt | 15 miscellaneous | 23 temperature | 31 reinspection required |

<p>3000 central lubrication <input type="checkbox"/> <input type="checkbox"/> <input type="checkbox"/> <input type="checkbox"/> <input type="checkbox"/></p> <p>3100 hydraulic motor <input type="checkbox"/> <input type="checkbox"/> <input type="checkbox"/> <input type="checkbox"/> <input type="checkbox"/></p> <p>3200 hydraulic lines <input type="checkbox"/> <input type="checkbox"/> <input type="checkbox"/> <input type="checkbox"/> <input type="checkbox"/></p> <p>3300 air compressor <input type="checkbox"/> <input type="checkbox"/> <input type="checkbox"/> <input type="checkbox"/> <input type="checkbox"/></p> <p>3400 control panel <input type="checkbox"/> <input type="checkbox"/> <input type="checkbox"/> <input type="checkbox"/> <input type="checkbox"/></p> <p>3500 concrete pump <input type="checkbox"/> <input type="checkbox"/> <input type="checkbox"/> <input type="checkbox"/> <input type="checkbox"/></p> <p>3700 S-valve <input type="checkbox"/> <input type="checkbox"/> <input type="checkbox"/> <input type="checkbox"/> <input type="checkbox"/></p> <p>3800 hopper <input type="checkbox"/> <input type="checkbox"/> <input type="checkbox"/> <input type="checkbox"/> <input type="checkbox"/></p> <p>4100 sub frame <input type="checkbox"/> <input type="checkbox"/> <input type="checkbox"/> <input type="checkbox"/> <input type="checkbox"/></p> <p>4200 water tank <input type="checkbox"/> <input type="checkbox"/> <input type="checkbox"/> <input type="checkbox"/> <input type="checkbox"/></p> <p>4300 axle <input type="checkbox"/> <input type="checkbox"/> <input type="checkbox"/> <input type="checkbox"/> <input type="checkbox"/></p> <p>4400 water pump <input type="checkbox"/> <input type="checkbox"/> <input type="checkbox"/> <input type="checkbox"/> <input type="checkbox"/></p> <p>4500 vibrator <input type="checkbox"/> <input type="checkbox"/> <input type="checkbox"/> <input type="checkbox"/> <input type="checkbox"/></p>	<p>4600 safety guards, equipment</p> <p>4601 stair <input type="checkbox"/> <input type="checkbox"/> <input type="checkbox"/> <input type="checkbox"/> <input type="checkbox"/></p> <p>4602 safety for stair <input type="checkbox"/> <input type="checkbox"/> <input type="checkbox"/> <input type="checkbox"/> <input type="checkbox"/></p> <p>4603 handrail <input type="checkbox"/> <input type="checkbox"/> <input type="checkbox"/> <input type="checkbox"/> <input type="checkbox"/></p> <p>4604 hopper grid (fixing device) <input type="checkbox"/> <input type="checkbox"/> <input type="checkbox"/> <input type="checkbox"/> <input type="checkbox"/></p> <p>4606 distance of grid rods <input type="checkbox"/> <input type="checkbox"/> <input type="checkbox"/> <input type="checkbox"/> <input type="checkbox"/></p> <p>4607 distance from grid to agitator <input type="checkbox"/> <input type="checkbox"/> <input type="checkbox"/> <input type="checkbox"/> <input type="checkbox"/></p> <p>4609 agitator have to stop if grid is open <input type="checkbox"/> <input type="checkbox"/> <input type="checkbox"/> <input type="checkbox"/> <input type="checkbox"/></p> <p>4610 accumulator have to dump if grid is open <input type="checkbox"/> <input type="checkbox"/> <input type="checkbox"/> <input type="checkbox"/> <input type="checkbox"/></p> <p>4612 cleaning flap hopper <input type="checkbox"/> <input type="checkbox"/> <input type="checkbox"/> <input type="checkbox"/> <input type="checkbox"/></p> <p>4613 safety grid into water box <input type="checkbox"/> <input type="checkbox"/> <input type="checkbox"/> <input type="checkbox"/> <input type="checkbox"/></p>
--	---

Notes:

Inspection report for concrete pump

Inspection report Nr: _____ Machine-Nr: _____

Error code:

00 no objections	08 corrosion	16 porous	24 deformation
01 cracks	09 lacquer failures	17 burned through	25 bear movement
02 broken	10 fraying	18 not fixed	26 lubrication
03 leaky	11 scratched	19 clemp	27 readability
04 no function	12 bendet	20 sawing	28 missing components
05 low lifetime	13 noises	21 contaminated	29 hydraulical
06 worn out	14 vibration	22 bad contact	30 electrical
07 dirt	15 miscellaneous	23 temperature	31 reinspection required

4614 cover for rotating wave

4616 cover for chains

4617 cover for shift cylinder

4618 cover for moving parts

4619 cover for the exhaust pipe

4700 electrical system

4701 function of actuator component

4702 emergency stop function

4703 ground connections

4704 cables and wiring harness

4705 temperature switch

4800 outrigger - system

4801 transportation lock

4802 locking device

4803 backing plate

4804 jack cylinder connections

4805 pressure adjustment of jack cylinder

4900 miscellaneous

4901 additional assembled part from operator

4902 changes through operator

Competent inspector:

Date:

Name:

Signature:
(stamp)

Customer:

Signature:
(stamp)

This test report is filed into the test book

Inspection report for concrete booms

Inspection report -Nr:	Machine-Nr	Hours of operation:	
		Concrete output m³:	
Company:	Post code:	City:	
Boom Type:	Boom Nr.	NL	WV

Proof – Result of the Tests

without defects	defects	reinspection required	shut down
<input type="checkbox"/>	<input type="checkbox"/>	<input type="checkbox"/>	<input type="checkbox"/>

Reinspection until date:

Error code:

- | | | | |
|------------------|---------------------|-------------------|--------------------------|
| 00 no objections | 08 corrosion | 16 porous | 24 deformation |
| 01 cracks | 09 lacquer failures | 17 burned through | 25 bear movement |
| 02 broken | 10 fraying | 18 not fixed | 26 lubrication |
| 03 leaky | 11 scratched | 19 clemp | 27 readability |
| 04 no function | 12 bendet | 20 sawing | 28 missing components |
| 05 low lifetime | 13 noises | 21 contaminated | 29 hydraulical |
| 06 worn out | 14 vibration | 22 bad contact | 30 electrical |
| 07 dirt | 15 miscellaneous | 23 temperature | 31 reinspection required |

<p>100 documents</p> <p>101 instruction manual <input type="checkbox"/> <input type="checkbox"/> <input type="checkbox"/> <input type="checkbox"/> <input type="checkbox"/></p> <p>102 spare parts list <input type="checkbox"/> <input type="checkbox"/> <input type="checkbox"/> <input type="checkbox"/> <input type="checkbox"/></p> <p>200 sub frame</p> <p>201 frame connection cpl. <input type="checkbox"/> <input type="checkbox"/> <input type="checkbox"/> <input type="checkbox"/> <input type="checkbox"/></p> <p>300 outrigger front R+L</p> <p>301 transportation safety device <input type="checkbox"/> <input type="checkbox"/> <input type="checkbox"/> <input type="checkbox"/> <input type="checkbox"/></p> <p>302 outrigger <input type="checkbox"/> <input type="checkbox"/> <input type="checkbox"/> <input type="checkbox"/> <input type="checkbox"/></p> <p>303 extension box <input type="checkbox"/> <input type="checkbox"/> <input type="checkbox"/> <input type="checkbox"/> <input type="checkbox"/></p> <p>304 locking device <input type="checkbox"/> <input type="checkbox"/> <input type="checkbox"/> <input type="checkbox"/> <input type="checkbox"/></p> <p>305 slewing bearing <input type="checkbox"/> <input type="checkbox"/> <input type="checkbox"/> <input type="checkbox"/> <input type="checkbox"/></p> <p>306 turn locking device <input type="checkbox"/> <input type="checkbox"/> <input type="checkbox"/> <input type="checkbox"/> <input type="checkbox"/></p> <p>307 support safeguard <input type="checkbox"/> <input type="checkbox"/> <input type="checkbox"/> <input type="checkbox"/> <input type="checkbox"/></p> <p>308 support plate <input type="checkbox"/> <input type="checkbox"/> <input type="checkbox"/> <input type="checkbox"/> <input type="checkbox"/></p> <p>309 fixing of jack cylinder <input type="checkbox"/> <input type="checkbox"/> <input type="checkbox"/> <input type="checkbox"/> <input type="checkbox"/></p> <p>310 jack cylinder <input type="checkbox"/> <input type="checkbox"/> <input type="checkbox"/> <input type="checkbox"/> <input type="checkbox"/></p>	<p>311 swing cylinder <input type="checkbox"/> <input type="checkbox"/> <input type="checkbox"/> <input type="checkbox"/> <input type="checkbox"/></p> <p>312 telescopic-cylinder <input type="checkbox"/> <input type="checkbox"/> <input type="checkbox"/> <input type="checkbox"/> <input type="checkbox"/></p> <p>313 pressure adjustment <input type="checkbox"/> <input type="checkbox"/> <input type="checkbox"/> <input type="checkbox"/> <input type="checkbox"/></p> <p>400 outrigger rear L+R</p> <p>401 transportation safety device <input type="checkbox"/> <input type="checkbox"/> <input type="checkbox"/> <input type="checkbox"/> <input type="checkbox"/></p> <p>402 outrigger <input type="checkbox"/> <input type="checkbox"/> <input type="checkbox"/> <input type="checkbox"/> <input type="checkbox"/></p> <p>403 extension box <input type="checkbox"/> <input type="checkbox"/> <input type="checkbox"/> <input type="checkbox"/> <input type="checkbox"/></p> <p>405 locking device <input type="checkbox"/> <input type="checkbox"/> <input type="checkbox"/> <input type="checkbox"/> <input type="checkbox"/></p> <p>Notes:</p> <hr/> <hr/> <hr/> <hr/> <hr/>
--	---

Inspection report for concrete booms

Inspection report Nr: _____ Boom type: _____ Machine-Nr: _____

Error code:

- | | | | |
|------------------|---------------------|-------------------|--------------------------|
| 00 no objections | 08 corrosion | 16 porous | 24 deformation |
| 01 cracks | 09 lacquer failures | 17 burned through | 25 bear movement |
| 02 broken | 10 fraying | 18 not fixed | 26 lubrication |
| 03 leaky | 11 scratched | 19 clomp | 27 readability |
| 04 no function | 12 bendet | 20 sawing | 28 missing components |
| 05 low lifetime | 13 noises | 21 contaminated | 29 hydraulic |
| 06 worn out | 14 vibration | 22 bad contact | 30 electrical |
| 07 dirt | 15 miscellaneous | 23 temperature | 31 reinspection required |

<p>406 slewing bearing <input type="checkbox"/> <input type="checkbox"/> <input type="checkbox"/> <input type="checkbox"/> <input type="checkbox"/></p> <p>407 turn locking device <input type="checkbox"/> <input type="checkbox"/> <input type="checkbox"/> <input type="checkbox"/> <input type="checkbox"/></p> <p>408 support safeguard <input type="checkbox"/> <input type="checkbox"/> <input type="checkbox"/> <input type="checkbox"/> <input type="checkbox"/></p> <p>409 support plate <input type="checkbox"/> <input type="checkbox"/> <input type="checkbox"/> <input type="checkbox"/> <input type="checkbox"/></p> <p>410 fixing of jack cylinder <input type="checkbox"/> <input type="checkbox"/> <input type="checkbox"/> <input type="checkbox"/> <input type="checkbox"/></p> <p>411 jack cylinder <input type="checkbox"/> <input type="checkbox"/> <input type="checkbox"/> <input type="checkbox"/> <input type="checkbox"/></p> <p>412 swing cylinder <input type="checkbox"/> <input type="checkbox"/> <input type="checkbox"/> <input type="checkbox"/> <input type="checkbox"/></p> <p>413 telescopic cylinder <input type="checkbox"/> <input type="checkbox"/> <input type="checkbox"/> <input type="checkbox"/> <input type="checkbox"/></p> <p>500 pedestal</p> <p>501 pedestal mounting <input type="checkbox"/> <input type="checkbox"/> <input type="checkbox"/> <input type="checkbox"/> <input type="checkbox"/></p> <p>502 sub frame <input type="checkbox"/> <input type="checkbox"/> <input type="checkbox"/> <input type="checkbox"/> <input type="checkbox"/></p> <p>503 truck frame <input type="checkbox"/> <input type="checkbox"/> <input type="checkbox"/> <input type="checkbox"/> <input type="checkbox"/></p> <p>504 pedestal (structure) <input type="checkbox"/> <input type="checkbox"/> <input type="checkbox"/> <input type="checkbox"/> <input type="checkbox"/></p> <p>505 boom valve without leaking <input type="checkbox"/> <input type="checkbox"/> <input type="checkbox"/> <input type="checkbox"/> <input type="checkbox"/></p> <p>506 boom rest <input type="checkbox"/> <input type="checkbox"/> <input type="checkbox"/> <input type="checkbox"/> <input type="checkbox"/></p> <p>507 transportation safety device <input type="checkbox"/> <input type="checkbox"/> <input type="checkbox"/> <input type="checkbox"/> <input type="checkbox"/></p> <p>508 hydraulic line <input type="checkbox"/> <input type="checkbox"/> <input type="checkbox"/> <input type="checkbox"/> <input type="checkbox"/></p> <p>600 slewing head with ball pivot</p> <p>601 slewing head <input type="checkbox"/> <input type="checkbox"/> <input type="checkbox"/> <input type="checkbox"/> <input type="checkbox"/></p> <p>602 ball pivot ring <input type="checkbox"/> <input type="checkbox"/> <input type="checkbox"/> <input type="checkbox"/> <input type="checkbox"/></p> <p>603 mounting ball pivot ring <input type="checkbox"/> <input type="checkbox"/> <input type="checkbox"/> <input type="checkbox"/> <input type="checkbox"/></p> <p>604 drive pinion <input type="checkbox"/> <input type="checkbox"/> <input type="checkbox"/> <input type="checkbox"/> <input type="checkbox"/></p>	<p>605 slewing drive mounting <input type="checkbox"/> <input type="checkbox"/> <input type="checkbox"/> <input type="checkbox"/> <input type="checkbox"/></p> <p>606 slewing stop device <input type="checkbox"/> <input type="checkbox"/> <input type="checkbox"/> <input type="checkbox"/> <input type="checkbox"/></p> <p>607 slewing drive (tooth backlash) <input type="checkbox"/> <input type="checkbox"/> <input type="checkbox"/> <input type="checkbox"/> <input type="checkbox"/></p> <p>608 slewing drive <input type="checkbox"/> <input type="checkbox"/> <input type="checkbox"/> <input type="checkbox"/> <input type="checkbox"/></p> <p>609 brake function <input type="checkbox"/> <input type="checkbox"/> <input type="checkbox"/> <input type="checkbox"/> <input type="checkbox"/></p> <p>610 speed <input type="checkbox"/> <input type="checkbox"/> <input type="checkbox"/> <input type="checkbox"/> <input type="checkbox"/></p> <p>611 pressure setting <input type="checkbox"/> <input type="checkbox"/> <input type="checkbox"/> <input type="checkbox"/> <input type="checkbox"/></p> <p>612 hydraulic lines <input type="checkbox"/> <input type="checkbox"/> <input type="checkbox"/> <input type="checkbox"/> <input type="checkbox"/></p> <p>700 slewing head with slewing column</p> <p>701 slewing head <input type="checkbox"/> <input type="checkbox"/> <input type="checkbox"/> <input type="checkbox"/> <input type="checkbox"/></p> <p>702 slewing column bearing <input type="checkbox"/> <input type="checkbox"/> <input type="checkbox"/> <input type="checkbox"/> <input type="checkbox"/></p> <p>703 slewing drive (tooth backlash) <input type="checkbox"/> <input type="checkbox"/> <input type="checkbox"/> <input type="checkbox"/> <input type="checkbox"/></p> <p>704 speed <input type="checkbox"/> <input type="checkbox"/> <input type="checkbox"/> <input type="checkbox"/> <input type="checkbox"/></p> <p>705 pressure settings <input type="checkbox"/> <input type="checkbox"/> <input type="checkbox"/> <input type="checkbox"/> <input type="checkbox"/></p> <p>706 hydraulic lines <input type="checkbox"/> <input type="checkbox"/> <input type="checkbox"/> <input type="checkbox"/> <input type="checkbox"/></p> <p>707 swivel cylinder <input type="checkbox"/> <input type="checkbox"/> <input type="checkbox"/> <input type="checkbox"/> <input type="checkbox"/></p> <p>Notes:</p> <hr/> <hr/> <hr/> <hr/>
---	---

Inspection report for concrete booms

Inspection report Nr: _____ Boom type: _____ Machine-Nr: _____

- | | | | |
|------------------|---------------------|-------------------|--------------------------|
| Error code: | | | |
| 00 no objections | 08 corrosion | 16 porous | 24 deformation |
| 01 cracks | 09 lacquer failures | 17 burned through | 25 bear movement |
| 02 broken | 10 fraying | 18 not fixed | 26 lubrication |
| 03 leaky | 11 scratched | 19 clomp | 27 readability |
| 04 no function | 12 bendet | 20 sawing | 28 missing components |
| 05 low lifetime | 13 noises | 21 contaminated | 29 hydraulical |
| 06 worn out | 14 vibration | 22 bad contact | 30 electrical |
| 07 dirt | 15 miscellaneous | 23 temperature | 31 reinspection required |

<p>800 boom</p> <p>801 „Arm 1“ <input type="checkbox"/> <input type="checkbox"/> <input type="checkbox"/> <input type="checkbox"/> <input type="checkbox"/></p> <p>802 bracket conveying line <input type="checkbox"/> <input type="checkbox"/> <input type="checkbox"/> <input type="checkbox"/> <input type="checkbox"/></p> <p>803 Drop hook <input type="checkbox"/> <input type="checkbox"/> <input type="checkbox"/> <input type="checkbox"/> <input type="checkbox"/></p> <p>804 „Arm 2“ <input type="checkbox"/> <input type="checkbox"/> <input type="checkbox"/> <input type="checkbox"/> <input type="checkbox"/></p> <p>805 bracket conveying line <input type="checkbox"/> <input type="checkbox"/> <input type="checkbox"/> <input type="checkbox"/> <input type="checkbox"/></p> <p>806 Drop hook <input type="checkbox"/> <input type="checkbox"/> <input type="checkbox"/> <input type="checkbox"/> <input type="checkbox"/></p> <p>807 „Arm 3“ <input type="checkbox"/> <input type="checkbox"/> <input type="checkbox"/> <input type="checkbox"/> <input type="checkbox"/></p> <p>808 bracket conveying line <input type="checkbox"/> <input type="checkbox"/> <input type="checkbox"/> <input type="checkbox"/> <input type="checkbox"/></p> <p>809 guidance and interlock of the arm <input type="checkbox"/> <input type="checkbox"/> <input type="checkbox"/> <input type="checkbox"/> <input type="checkbox"/></p> <p>810 „Arm 4“ <input type="checkbox"/> <input type="checkbox"/> <input type="checkbox"/> <input type="checkbox"/> <input type="checkbox"/></p> <p>811 bracket conveying line <input type="checkbox"/> <input type="checkbox"/> <input type="checkbox"/> <input type="checkbox"/> <input type="checkbox"/></p> <p>812 guidance and interlock of the arm <input type="checkbox"/> <input type="checkbox"/> <input type="checkbox"/> <input type="checkbox"/> <input type="checkbox"/></p> <p>813 „Arm 5“ <input type="checkbox"/> <input type="checkbox"/> <input type="checkbox"/> <input type="checkbox"/> <input type="checkbox"/></p> <p>814 bracket conveying line <input type="checkbox"/> <input type="checkbox"/> <input type="checkbox"/> <input type="checkbox"/> <input type="checkbox"/></p> <p>815 guidance and interlock of the arm <input type="checkbox"/> <input type="checkbox"/> <input type="checkbox"/> <input type="checkbox"/> <input type="checkbox"/></p> <p>900 joint „A“</p> <p>901 boom <input type="checkbox"/> <input type="checkbox"/> <input type="checkbox"/> <input type="checkbox"/> <input type="checkbox"/></p> <p>902 link lever <input type="checkbox"/> <input type="checkbox"/> <input type="checkbox"/> <input type="checkbox"/> <input type="checkbox"/></p> <p>903 forcing rod <input type="checkbox"/> <input type="checkbox"/> <input type="checkbox"/> <input type="checkbox"/> <input type="checkbox"/></p> <p>904 pin <input type="checkbox"/> <input type="checkbox"/> <input type="checkbox"/> <input type="checkbox"/> <input type="checkbox"/></p> <p>905 cylinder <input type="checkbox"/> <input type="checkbox"/> <input type="checkbox"/> <input type="checkbox"/> <input type="checkbox"/></p>	<p>906 boom speed <input type="checkbox"/> <input type="checkbox"/> <input type="checkbox"/> <input type="checkbox"/> <input type="checkbox"/></p> <p>907 pressure settings <input type="checkbox"/> <input type="checkbox"/> <input type="checkbox"/> <input type="checkbox"/> <input type="checkbox"/></p> <p>908 hydraulic lines <input type="checkbox"/> <input type="checkbox"/> <input type="checkbox"/> <input type="checkbox"/> <input type="checkbox"/></p> <p>909 load holding valve (piston side) <input type="checkbox"/> <input type="checkbox"/> <input type="checkbox"/> <input type="checkbox"/> <input type="checkbox"/></p> <p>910 load holding valve (rod side) <input type="checkbox"/> <input type="checkbox"/> <input type="checkbox"/> <input type="checkbox"/> <input type="checkbox"/></p> <p>1000 joint „B“</p> <p>1001 boom <input type="checkbox"/> <input type="checkbox"/> <input type="checkbox"/> <input type="checkbox"/> <input type="checkbox"/></p> <p>1002 link lever <input type="checkbox"/> <input type="checkbox"/> <input type="checkbox"/> <input type="checkbox"/> <input type="checkbox"/></p> <p>1003 forcing rod <input type="checkbox"/> <input type="checkbox"/> <input type="checkbox"/> <input type="checkbox"/> <input type="checkbox"/></p> <p>1004 pin <input type="checkbox"/> <input type="checkbox"/> <input type="checkbox"/> <input type="checkbox"/> <input type="checkbox"/></p> <p>1005 cylinder <input type="checkbox"/> <input type="checkbox"/> <input type="checkbox"/> <input type="checkbox"/> <input type="checkbox"/></p> <p>1006 boom speed <input type="checkbox"/> <input type="checkbox"/> <input type="checkbox"/> <input type="checkbox"/> <input type="checkbox"/></p> <p>1007 pressure settings <input type="checkbox"/> <input type="checkbox"/> <input type="checkbox"/> <input type="checkbox"/> <input type="checkbox"/></p> <p>1008 hydraulic lines <input type="checkbox"/> <input type="checkbox"/> <input type="checkbox"/> <input type="checkbox"/> <input type="checkbox"/></p> <p>1009 load holding valve (piston side) <input type="checkbox"/> <input type="checkbox"/> <input type="checkbox"/> <input type="checkbox"/> <input type="checkbox"/></p> <p>1010 load holding valve (rod side) <input type="checkbox"/> <input type="checkbox"/> <input type="checkbox"/> <input type="checkbox"/> <input type="checkbox"/></p> <p>Notes:</p> <hr/> <hr/> <hr/> <hr/>
--	---

Inspection report for concrete booms

Inspection report Nr: _____ Boom type: _____ Machine-Nr: _____

- | | | | |
|------------------|---------------------|-------------------|--------------------------|
| Error code: | | | |
| 00 no objections | 08 corrosion | 16 porous | 24 deformation |
| 01 cracks | 09 lacquer failures | 17 burned through | 25 bear movement |
| 02 broken | 10 fraying | 18 not fixed | 26 lubrication |
| 03 leaky | 11 scratched | 19 clemp | 27 readability |
| 04 no function | 12 bendet | 20 sawing | 28 missing components |
| 05 low lifetime | 13 noises | 21 contaminated | 29 hydraulical |
| 06 worn out | 14 vibration | 22 bad contact | 30 electrical |
| 07 dirt | 15 miscellaneous | 23 temperature | 31 reinspection required |

1100 joint "C"

- | | | | | | |
|--|--------------------------|--------------------------|--------------------------|--------------------------|--------------------------|
| 1101 boom | <input type="checkbox"/> | <input type="checkbox"/> | <input type="checkbox"/> | <input type="checkbox"/> | <input type="checkbox"/> |
| 1102 link lever | <input type="checkbox"/> | <input type="checkbox"/> | <input type="checkbox"/> | <input type="checkbox"/> | <input type="checkbox"/> |
| 1103 forcing rod | <input type="checkbox"/> | <input type="checkbox"/> | <input type="checkbox"/> | <input type="checkbox"/> | <input type="checkbox"/> |
| 1104 pin | <input type="checkbox"/> | <input type="checkbox"/> | <input type="checkbox"/> | <input type="checkbox"/> | <input type="checkbox"/> |
| 1105 cylinder | <input type="checkbox"/> | <input type="checkbox"/> | <input type="checkbox"/> | <input type="checkbox"/> | <input type="checkbox"/> |
| 1106 boom speed | <input type="checkbox"/> | <input type="checkbox"/> | <input type="checkbox"/> | <input type="checkbox"/> | <input type="checkbox"/> |
| 1107 pressure settings | <input type="checkbox"/> | <input type="checkbox"/> | <input type="checkbox"/> | <input type="checkbox"/> | <input type="checkbox"/> |
| 1108 hydraulic lines | <input type="checkbox"/> | <input type="checkbox"/> | <input type="checkbox"/> | <input type="checkbox"/> | <input type="checkbox"/> |
| 1109 load holding valve
(piston side) | <input type="checkbox"/> | <input type="checkbox"/> | <input type="checkbox"/> | <input type="checkbox"/> | <input type="checkbox"/> |
| 1110 load hokding valve
(rod side) | <input type="checkbox"/> | <input type="checkbox"/> | <input type="checkbox"/> | <input type="checkbox"/> | <input type="checkbox"/> |

1200 joint "D"

- | | | | | | |
|--|--------------------------|--------------------------|--------------------------|--------------------------|--------------------------|
| 1201 boom | <input type="checkbox"/> | <input type="checkbox"/> | <input type="checkbox"/> | <input type="checkbox"/> | <input type="checkbox"/> |
| 1202 link lever | <input type="checkbox"/> | <input type="checkbox"/> | <input type="checkbox"/> | <input type="checkbox"/> | <input type="checkbox"/> |
| 1203 forcing rod | <input type="checkbox"/> | <input type="checkbox"/> | <input type="checkbox"/> | <input type="checkbox"/> | <input type="checkbox"/> |
| 1204 pin | <input type="checkbox"/> | <input type="checkbox"/> | <input type="checkbox"/> | <input type="checkbox"/> | <input type="checkbox"/> |
| 1205 cylinder | <input type="checkbox"/> | <input type="checkbox"/> | <input type="checkbox"/> | <input type="checkbox"/> | <input type="checkbox"/> |
| 1206 boom speed | <input type="checkbox"/> | <input type="checkbox"/> | <input type="checkbox"/> | <input type="checkbox"/> | <input type="checkbox"/> |
| 1207 pressure settings | <input type="checkbox"/> | <input type="checkbox"/> | <input type="checkbox"/> | <input type="checkbox"/> | <input type="checkbox"/> |
| 1208 hydraulic lines | <input type="checkbox"/> | <input type="checkbox"/> | <input type="checkbox"/> | <input type="checkbox"/> | <input type="checkbox"/> |
| 1209 load holding valve
(piston side) | <input type="checkbox"/> | <input type="checkbox"/> | <input type="checkbox"/> | <input type="checkbox"/> | <input type="checkbox"/> |
| 1210 load holding valve
(rod side) | <input type="checkbox"/> | <input type="checkbox"/> | <input type="checkbox"/> | <input type="checkbox"/> | <input type="checkbox"/> |

1300 joint „E“

- | | | | | | |
|--|--------------------------|--------------------------|--------------------------|--------------------------|--------------------------|
| 1301 boom | <input type="checkbox"/> | <input type="checkbox"/> | <input type="checkbox"/> | <input type="checkbox"/> | <input type="checkbox"/> |
| 1302 link lever | <input type="checkbox"/> | <input type="checkbox"/> | <input type="checkbox"/> | <input type="checkbox"/> | <input type="checkbox"/> |
| 1303 forcing rod | <input type="checkbox"/> | <input type="checkbox"/> | <input type="checkbox"/> | <input type="checkbox"/> | <input type="checkbox"/> |
| 1304 pin | <input type="checkbox"/> | <input type="checkbox"/> | <input type="checkbox"/> | <input type="checkbox"/> | <input type="checkbox"/> |
| 1305 cylinder | <input type="checkbox"/> | <input type="checkbox"/> | <input type="checkbox"/> | <input type="checkbox"/> | <input type="checkbox"/> |
| 1306 boom speed | <input type="checkbox"/> | <input type="checkbox"/> | <input type="checkbox"/> | <input type="checkbox"/> | <input type="checkbox"/> |
| 1307 pressure settings | <input type="checkbox"/> | <input type="checkbox"/> | <input type="checkbox"/> | <input type="checkbox"/> | <input type="checkbox"/> |
| 1308 hydraulic lines | <input type="checkbox"/> | <input type="checkbox"/> | <input type="checkbox"/> | <input type="checkbox"/> | <input type="checkbox"/> |
| 1309 load holding valve
(piston side) | <input type="checkbox"/> | <input type="checkbox"/> | <input type="checkbox"/> | <input type="checkbox"/> | <input type="checkbox"/> |
| 1310 load holding valve
(rod side) | <input type="checkbox"/> | <input type="checkbox"/> | <input type="checkbox"/> | <input type="checkbox"/> | <input type="checkbox"/> |

1400 concrete delivery line

- | | | | | | |
|--|--------------------------|--------------------------|--------------------------|--------------------------|--------------------------|
| 1401 assembly of delivery
line DN | <input type="checkbox"/> | <input type="checkbox"/> | <input type="checkbox"/> | <input type="checkbox"/> | <input type="checkbox"/> |
| 1402 end hose
DN+lenght | <input type="checkbox"/> | <input type="checkbox"/> | <input type="checkbox"/> | <input type="checkbox"/> | <input type="checkbox"/> |
| 1403 delivery line
DN | <input type="checkbox"/> | <input type="checkbox"/> | <input type="checkbox"/> | <input type="checkbox"/> | <input type="checkbox"/> |
| 1404 rotating joints of -
delivery line | <input type="checkbox"/> | <input type="checkbox"/> | <input type="checkbox"/> | <input type="checkbox"/> | <input type="checkbox"/> |
| 1405 locking pin of the
coupling | <input type="checkbox"/> | <input type="checkbox"/> | <input type="checkbox"/> | <input type="checkbox"/> | <input type="checkbox"/> |

Notes:

--	--

Inspection report for concrete booms

Inspection report Nr: _____ Boom type: _____ Machine-Nr: _____

Error code:

00 no objections	08 corrosion	16 porous	24 deformation
01 cracks	09 lacquer failures	17 burned through	25 bear movement
02 broken	10 fraying	18 not fixed	26 lubrication
03 leaky	11 scratched	19 clemp	27 readability
04 no function	12 bendet	20 sawing	28 missing components
05 low lifetime	13 noises	21 contaminated	29 hydraulical
06 worn out	14 vibration	22 bad contact	30 electrical
07 dirt	15 miscellaneous	23 temperature	31 reinspection required

<p>1406 end hose safety device <input type="checkbox"/> <input type="checkbox"/> <input type="checkbox"/> <input type="checkbox"/> <input type="checkbox"/></p> <p>1407 reducer <input type="checkbox"/> <input type="checkbox"/> <input type="checkbox"/> <input type="checkbox"/> <input type="checkbox"/></p> <p>1408 gate elbow, elbow 6" <input type="checkbox"/> <input type="checkbox"/> <input type="checkbox"/> <input type="checkbox"/> <input type="checkbox"/></p> <p>1500 hydraulic system and hydraulic valves</p> <p>1501 Pressure relief valve <input type="checkbox"/> <input type="checkbox"/> <input type="checkbox"/> <input type="checkbox"/> <input type="checkbox"/></p> <p>1502 pressure settings <input type="checkbox"/> <input type="checkbox"/> <input type="checkbox"/> <input type="checkbox"/> <input type="checkbox"/></p> <p>1503 hydraulic lines <input type="checkbox"/> <input type="checkbox"/> <input type="checkbox"/> <input type="checkbox"/> <input type="checkbox"/></p> <p>1504 hand operating-(function) <input type="checkbox"/> <input type="checkbox"/> <input type="checkbox"/> <input type="checkbox"/> <input type="checkbox"/></p> <p>1505 boom control valve <input type="checkbox"/> <input type="checkbox"/> <input type="checkbox"/> <input type="checkbox"/> <input type="checkbox"/></p> <p>1506 hydraulic pump <input type="checkbox"/> <input type="checkbox"/> <input type="checkbox"/> <input type="checkbox"/> <input type="checkbox"/></p> <p>1600 electric equipment</p> <p>1601 remote control (functions) <input type="checkbox"/> <input type="checkbox"/> <input type="checkbox"/> <input type="checkbox"/> <input type="checkbox"/></p> <p>1602 emergency stop (function) <input type="checkbox"/> <input type="checkbox"/> <input type="checkbox"/> <input type="checkbox"/> <input type="checkbox"/></p> <p>1603 switch for outrigger function <input type="checkbox"/> <input type="checkbox"/> <input type="checkbox"/> <input type="checkbox"/> <input type="checkbox"/></p> <p>1604 switch for boom function <input type="checkbox"/> <input type="checkbox"/> <input type="checkbox"/> <input type="checkbox"/> <input type="checkbox"/></p> <p>1605 wiring harness <input type="checkbox"/> <input type="checkbox"/> <input type="checkbox"/> <input type="checkbox"/> <input type="checkbox"/></p> <p>1606 central lubrication <input type="checkbox"/> <input type="checkbox"/> <input type="checkbox"/> <input type="checkbox"/> <input type="checkbox"/></p>	<p>1700 sticker sets</p> <p>1701 safety hints <input type="checkbox"/> <input type="checkbox"/> <input type="checkbox"/> <input type="checkbox"/> <input type="checkbox"/></p> <p>1702 description <input type="checkbox"/> <input type="checkbox"/> <input type="checkbox"/> <input type="checkbox"/> <input type="checkbox"/></p> <p>1703 operating <input type="checkbox"/> <input type="checkbox"/> <input type="checkbox"/> <input type="checkbox"/> <input type="checkbox"/></p> <p>1704 short operating instruction <input type="checkbox"/> <input type="checkbox"/> <input type="checkbox"/> <input type="checkbox"/> <input type="checkbox"/></p> <p>1705 sticker „ don't use the boom as crane“ <input type="checkbox"/> <input type="checkbox"/> <input type="checkbox"/> <input type="checkbox"/> <input type="checkbox"/></p> <p>1706 sticker „guideline operating with boom- and concrete pump“ <input type="checkbox"/> <input type="checkbox"/> <input type="checkbox"/> <input type="checkbox"/> <input type="checkbox"/></p> <p>1707 name plate <input type="checkbox"/> <input type="checkbox"/> <input type="checkbox"/> <input type="checkbox"/> <input type="checkbox"/></p> <p>1708 sticker „danger high voltage“ <input type="checkbox"/> <input type="checkbox"/> <input type="checkbox"/> <input type="checkbox"/> <input type="checkbox"/></p> <p>Competent inspector:</p> <p>Date: _____</p> <p>Name: _____</p> <p>Signature: _____ (stamp)</p> <p>Customer:</p> <p>Signature: _____ (stamp)</p>
--	--

Inspection report for concrete pump

Inspection report Nr:	Machine-Nr:	Hours of operation:
		Concrete output m ³ :
Company:	Post code:	City:

NL	WV
----	----

Proof – Result of the tests

without defects	defects	reinspection required	shut down
<input type="checkbox"/>	<input type="checkbox"/>	<input type="checkbox"/>	<input type="checkbox"/>

Reinspection until date:

Error code:

- | | | | |
|------------------|---------------------|-------------------|--------------------------|
| 00 no objections | 08 corrosion | 16 porous | 24 deformation |
| 01 cracks | 09 lacquer failures | 17 burned through | 25 bear movement |
| 02 broken | 10 fraying | 18 not fixed | 26 lubrication |
| 03 leaky | 11 scratched | 19 clomp | 27 readability |
| 04 no fuction | 12 bendet | 20 sawing | 28 missing components |
| 05 low livetime | 13 noises | 21 contaminated | 29 hydraulical |
| 06 worn out | 14 vibration | 22 bad contact | 30 electrical |
| 07 dirt | 15 miscellaneous | 23 temperature | 31 reinspection required |

2000 documents

2001 operating manual

2002 spare parts list

2100 drive assembly

2101 coupling and flange

2200 gear box

2300 hydraulic pump (main)

2400 oil-tank

2500 drive shaft

2700 hydraulic control system

2701 pressure relief valve

2702 pressure setting

2703 hydraulic line

2704 mechanical operation by hand

2800 oil –cooler

2900 accumulator

2901 proofs of the required tests according to accumulator regulation

2902 pressure gauge

Notes:

Inspection report for concrete pump

Inspection report Nr: _____ Machine-Nr: _____

Error code:

- | | | | |
|------------------|---------------------|-------------------|--------------------------|
| 00 no objections | 08 corrosion | 16 porous | 24 deformation |
| 01 cracks | 09 lacquer failures | 17 burned through | 25 bear movement |
| 02 broken | 10 fraying | 18 not fixed | 26 lubrication |
| 03 leaky | 11 scratched | 19 clemp | 27 readability |
| 04 no function | 12 bendet | 20 sawing | 28 missing components |
| 05 low lifetime | 13 noises | 21 contamitated | 29 hydraulical |
| 06 worn out | 14 vibration | 22 bad contact | 30 electrical |
| 07 dirt | 15 miscellaneous | 23 temperature | 31 reinspection required |

- | | | | | | |
|--------------------------|--------------------------|--------------------------|--------------------------|--------------------------|--------------------------|
| 3000 central lubrication | <input type="checkbox"/> | <input type="checkbox"/> | <input type="checkbox"/> | <input type="checkbox"/> | <input type="checkbox"/> |
| 3100 hydraulic motor | <input type="checkbox"/> | <input type="checkbox"/> | <input type="checkbox"/> | <input type="checkbox"/> | <input type="checkbox"/> |
| 3200 hydraulic lines | <input type="checkbox"/> | <input type="checkbox"/> | <input type="checkbox"/> | <input type="checkbox"/> | <input type="checkbox"/> |
| 3300 air compressor | <input type="checkbox"/> | <input type="checkbox"/> | <input type="checkbox"/> | <input type="checkbox"/> | <input type="checkbox"/> |
| 3400 control panel | <input type="checkbox"/> | <input type="checkbox"/> | <input type="checkbox"/> | <input type="checkbox"/> | <input type="checkbox"/> |
| 3500 concrete pump | <input type="checkbox"/> | <input type="checkbox"/> | <input type="checkbox"/> | <input type="checkbox"/> | <input type="checkbox"/> |
| 3700 S-valve | <input type="checkbox"/> | <input type="checkbox"/> | <input type="checkbox"/> | <input type="checkbox"/> | <input type="checkbox"/> |
| 3800 hopper | <input type="checkbox"/> | <input type="checkbox"/> | <input type="checkbox"/> | <input type="checkbox"/> | <input type="checkbox"/> |
| 4100 sub frame | <input type="checkbox"/> | <input type="checkbox"/> | <input type="checkbox"/> | <input type="checkbox"/> | <input type="checkbox"/> |
| 4200 water tank | <input type="checkbox"/> | <input type="checkbox"/> | <input type="checkbox"/> | <input type="checkbox"/> | <input type="checkbox"/> |
| 4300 axle | <input type="checkbox"/> | <input type="checkbox"/> | <input type="checkbox"/> | <input type="checkbox"/> | <input type="checkbox"/> |
| 4400 water pump | <input type="checkbox"/> | <input type="checkbox"/> | <input type="checkbox"/> | <input type="checkbox"/> | <input type="checkbox"/> |
| 4500 vibrator | <input type="checkbox"/> | <input type="checkbox"/> | <input type="checkbox"/> | <input type="checkbox"/> | <input type="checkbox"/> |

4600 safety guards, equipment

- | | | | | | |
|--|--------------------------|--------------------------|--------------------------|--------------------------|--------------------------|
| 4601 stair | <input type="checkbox"/> | <input type="checkbox"/> | <input type="checkbox"/> | <input type="checkbox"/> | <input type="checkbox"/> |
| 4602 safety for stair | <input type="checkbox"/> | <input type="checkbox"/> | <input type="checkbox"/> | <input type="checkbox"/> | <input type="checkbox"/> |
| 4603 handrail | <input type="checkbox"/> | <input type="checkbox"/> | <input type="checkbox"/> | <input type="checkbox"/> | <input type="checkbox"/> |
| 4604 hopper grid
(fixing device) | <input type="checkbox"/> | <input type="checkbox"/> | <input type="checkbox"/> | <input type="checkbox"/> | <input type="checkbox"/> |
| 4606 distance of grid rods | <input type="checkbox"/> | <input type="checkbox"/> | <input type="checkbox"/> | <input type="checkbox"/> | <input type="checkbox"/> |
| 4607 distance from grid to
agitator | <input type="checkbox"/> | <input type="checkbox"/> | <input type="checkbox"/> | <input type="checkbox"/> | <input type="checkbox"/> |
| 4609 agitator have to stop
if grid is open | <input type="checkbox"/> | <input type="checkbox"/> | <input type="checkbox"/> | <input type="checkbox"/> | <input type="checkbox"/> |
| 4610 accumulator have to
dump if grid is open | <input type="checkbox"/> | <input type="checkbox"/> | <input type="checkbox"/> | <input type="checkbox"/> | <input type="checkbox"/> |
| 4612 cleaning flap hopper | <input type="checkbox"/> | <input type="checkbox"/> | <input type="checkbox"/> | <input type="checkbox"/> | <input type="checkbox"/> |
| 4613 safety grid into water
box | <input type="checkbox"/> | <input type="checkbox"/> | <input type="checkbox"/> | <input type="checkbox"/> | <input type="checkbox"/> |

Notes:

Inspection report for concrete pump

Inspection report Nr:

Machine-Nr:

Error code:

00 no objections	08 corrosion	16 porous	24 deformation
01 cracks	09 lacquer failures	17 burned through	25 bear movement
02 broken	10 fraying	18 not fixed	26 lubrication
03 leaky	11 scratched	19 clemp	27 readability
04 no function	12 bendet	20 sawing	28 missing components
05 low lifetime	13 noises	21 contamitated	29 hydraulical
06 worn out	14 vibration	22 bad contact	30 electrical
07 dirt	15 miscellaneous	23 temperature	31 reinspection required

- 4614 cover for rotating wave
- 4616 cover for chains
- 4617 cover for shift cylinder
- 4618 cover for moving parts
- 4619 cover for the exhaust pipe

4700 electrical system

- 4701 function of actuator component
- 4702 emergency stop function
- 4703 ground connections
- 4704 cables and wiring harness
- 4705 temperature switch

4800 outrigger - system

- 4801 transportation lock
- 4802 locking device
- 4803 backing plate

4804 jack cylinder connections

4805 pressure adjustment of jack cylinder

4900 miscellaneous

4901 additional assembled part from operator

4902 changes through operator

Competent inspector:

Date:

Name:

Signature:
(stamp)

Customer:

Signature:
(stamp)

This test report is filed into the test book