



*MODEL SHOWN: STANDARD  
HOPPER WITH DUAL SHIFT  
SWING CYLINDER UNIT*

**REED** TRAILER MOUNTED CONCRETE PUMP MODEL *B50* ILLUSTRATED PARTS MANUAL CONTAINS THE FOLLOWING GROUPS AND FIGURES:

### **GROUP 00 HOW TO USE PARTS MANUAL**

- FIGURE 00** TABLE OF CONTENTS
- FIGURE 01** HOW TO USE PARTS MANUAL
- FIGURE 02** HOW TO ORDER PARTS

### **GROUP 10 FINAL INSTALLATION**

- FIGURE 00** TABLE OF CONTENTS
- FIGURE 01** STANDARD HOPPER WITH SINGLE SHIFT INSTALLATION
- FIGURE 02** HARSH MIX HOPPER WITH SINGLE SHIFT INSTALLATION
- FIGURE 03** STANDARD HOPPER WITH DUAL SHIFT INSTALLATION
- FIGURE 04** HARSH MIX HOPPER WITH DUAL SHIFT INSTALLATION
- FIGURE 05** DECALASSEMBLY

### **GROUP 20 HOPPER INSTALLATION**

- FIGURE 00** TABLE OF CONTENTS
- FIGURE 01** STANDARD HOPPER INSTALLATION
- FIGURE 02** HARSH MIX HOPPER INSTALLATION
- FIGURE 03** HOPPER CLEAN OUT DOOR ASSEMBLY
- FIGURE 04** STANDARD HOPPER AGITATOR ASSEMBLY
- FIGURE 05** HARSH MIX HOPPER AGITATOR ASSEMBLY
- FIGURE 06** STANDARD HOPPER AGITATOR MOTOR ASSEMBLY
- FIGURE 07** HARSH MIX HOPPER AGITATOR MOTOR ASSEMBLY
- FIGURE 08** 3 SPOOL CONTROL VALVE ASSEMBLY
- FIGURE 09** 3 SPOOL CONTROL VALVE SUBASSEMBLY

**GROUP 30 TANK INSTALLATION**

<b>FIGURE</b>	<b>00</b>	TABLE OF CONTENTS
<b>FIGURE</b>	<b>01</b>	TANK INSTALLATION
<b>FIGURE</b>	<b>02</b>	HYDRAULIC TANK ASSEMBLY
<b>FIGURE</b>	<b>03</b>	SWING TUBE CIRCUIT MANIFOLD ASSEMBLY
<b>FIGURE</b>	<b>04</b>	SWING TUBE CIRCUIT MAIN SOLENOID VALVE ASSEMBLY
<b>FIGURE</b>	<b>05</b>	SWING TUBE CIRCUIT PILOT SOLENOID VALVE ASSEMBLY
<b>FIGURE</b>	<b>06</b>	BALL VALVE ASSEMBLY
<b>FIGURE</b>	<b>07</b>	DRIVE CYLINDER CIRCUIT MANIFOLD ASSEMBLY
<b>FIGURE</b>	<b>08</b>	DRIVE CYLINDER CIRCUIT MAIN SOLENOID VALVE ASSEMBLY
<b>FIGURE</b>	<b>09</b>	DRIVE CYLINDER CIRCUIT PILOT SOLENOID VALVE ASSEMBLY
<b>FIGURE</b>	<b>10</b>	ACCUMULATOR ASSEMBLY
<b>FIGURE</b>	<b>11</b>	ACCUMULATOR BLADDER REPAIR KIT

**GROUP 40 POWER TRAIN INSTALLATION**

<b>FIGURE</b>	<b>00</b>	TABLE OF CONTENTS
<b>FIGURE</b>	<b>01</b>	POWER TRAIN INSTALLATION
<b>FIGURE</b>	<b>02</b>	HYDRAULIC PUMPS ASSEMBLY
<b>FIGURE</b>	<b>03</b>	SINGLE AUXILIARY PUMP ASSEMBLY
<b>FIGURE</b>	<b>04</b>	DOUBLE AUXILIARY PUMP ASSEMBLY
<b>FIGURE</b>	<b>05</b>	MAIN PUMP ASSEMBLY
<b>FIGURE</b>	<b>06</b>	BATTERY MOUNTING ASSEMBLY

**GROUP 50 CONTROLS INSTALLATION**

<b>FIGURE</b>	<b>00</b>	TABLE OF CONTENTS
<b>FIGURE</b>	<b>01</b>	CONTROLS INSTALLATION
<b>FIGURE</b>	<b>02</b>	CONTROL BOX ASSEMBLY
<b>FIGURE</b>	<b>03</b>	50 FEET CABLE REMOTE CONTROL ASSEMBLY
<b>FIGURE</b>	<b>04</b>	100 FEET CABLE REMOTE CONTROL ASSEMBLY
<b>FIGURE</b>	<b>05</b>	RADIO REMOTE CONTROL ASSEMBLY

**GROUP 60 PUMPING TRAIN INSTALLATION**

<b>FIGURE</b>	<b>00</b>	TABLE OF CONTENTS
<b>FIGURE</b>	<b>01</b>	SINGLE SHIFT PUMPING TRAIN INSTALLATION
<b>FIGURE</b>	<b>02</b>	DUAL SHIFT PUMPING TRAIN INSTALLATION
<b>FIGURE</b>	<b>03</b>	SINGLE SHIFT SWING VALVE ASSEMBLY
<b>FIGURE</b>	<b>04</b>	DUAL SHIFT SWING VALVE ASSEMBLY
<b>FIGURE</b>	<b>05</b>	SINGLE SHIFT SWING RAM CYLINDER SUBASSEMBLY
<b>FIGURE</b>	<b>06</b>	DUAL SHIFT SWING RAM CYLINDER SUBASSEMBLY
<b>FIGURE</b>	<b>07</b>	MATERIAL CYLINDER ASSEMBLY
<b>FIGURE</b>	<b>08</b>	FLUSHBOX ASSEMBLY
<b>FIGURE</b>	<b>09</b>	HYDRAULIC DRIVE CYLINDER ASSEMBLY
<b>FIGURE</b>	<b>10</b>	HYDRAULIC DRIVE CYLINDER SUBASSEMBLY



# TRAILER MOUNTED PUMP MODEL B50IL- LUSTRATED PART MANUAL

**B50**  
**PARTS**  
GROUP 00  
FIGURE 00  
PAGE 03

## GROUP 70 FRAME INSTALLATION

FIGURE	00	TABLE OF CONTENTS
FIGURE	01	FRAME INSTALLATION
FIGURE	02	HUB AND BRAKE ASSEMBLY
FIGURE	03	NON-OPERATOR SIDE ELECTRIC BRAKE ASSEMBLY
FIGURE	04	OPERATOR SIDE ELECTRIC BRAKE ASSEMBLY

## GROUP 80 OPTIONAL INSTALLATION

FIGURE	00	TABLE OF CONTENTS
FIGURE	01	OPTIONAL INSTALLATION
FIGURE	02	LUBE SYSTEM ASSEMBLY
FIGURE	03	12 VOLT LUBE PUMP ASSEMBLY
FIGURE	04	HOPPER VIBRATOR ASSEMBLY
FIGURE	05	THROTTLE SOLENOID ASSEMBLY
FIGURE	06	ACCUMULATOR CHARGE KIT
FIGURE	07	OPTIONAL TOOL KIT ASSEMBLY
FIGURE	08	ACTUATOR BRAKES ASSEMBLY
FIGURE	09	WATER PUMP INSTALLATION
FIGURE	10	WATER PUMP CONTROL VALVE ASSEMBLY
FIGURE	11	WATER PUMP MOTOR ASSEMBLY
FIGURE	12	WATER PUMP ASSEMBLY
FIGURE	13	NON-OPERATOR SIDE HYDRAULIC BRAKE ASSEMBLY
FIGURE	14	OPERATOR SIDE HYDRAULIC BRAKE ASSEMBLY
FIGURE	15	HYDRAULIC OUTRIGGER CYLINDER ASSEMBLY
FIGURE	16	1 SPOOL CONTROL VALVE ASSEMBLY
FIGURE	17	1 SPOOL CONTROL VALVE SUBASSEMBLY
FIGURE	18	2 SPOOL CONTROL VALVE ASSEMBLY
FIGURE	19	2 SPOOL CONTROL VALVE SUBASSEMBLY
FIGURE	20	SIDE DOOR ASSEMBLY
FIGURE	21	50 FEET STROKE COUNTER REMOTE CONTROLLER
FIGURE	22	100 FEET STROKE COUNTER REMOTE CONTROLLER



*MODEL SHOWN: STANDARD HOPPER WITH  
DUAL SHIFT SWING CYLINDER UNIT*

REVISION:



# TRAILER MOUNTED PUMP MODEL *B50* HOW TO USE PART MANUAL

*B50*  
PARTS  
GROUP 00  
FIGURE 01  
PAGE 01

## I. Purpose

This parts manual is prepared, issued and/or revised by **REED** Manufacturing, for the exclusive use of its customers and is intended for use in provisioning, requisitioning, storing and issuing replaceable **REED** trailer mounted pump Model *B50*. The contents are proprietary to **REED** and are subject to change without notice. The use of any part of this document by any other person or persons or for any other purpose without the written consent of **REED** is expressly prohibited. In addition, **REED** expressly disclaims any and all responsibility arising in or any way related to such **REED**'s prior written consent thereto.

The parts number consent of this document, arrangement and breakdown sequence of items is compatible with Military Standards (**MS**) and Air Transport Association Specification (**ATA**).

## II. GENERAL SYSTEM OF ASSEMBLY ORDER - Detailed Parts List (Refer to Next Page)

1. This area refers to the corresponding illustration

### MODEL - GROUP - FIGURE - PAGE

A. **MODEL** shows which is **REED**'s model number.

B. **GROUP** should be divided with:

00	MODEL <i>B50</i> PARTS MANUAL
10	FINAL INSTALLATION
20	HOPPER INSTALLATION
30	TANK INSTALLATION
40	POWER TRAIN INSTALLATION
50	CONTROL INSTALLATION
60	PUMPING TRAIN INSTALLATION
70	FRAME INSTALLATION
80	OPTIONAL INSTALLATION

C. **FIGURE** belong to the group. Please see page of contents and each group.

D. **PAGE** numbers follow to the right of each figure number.

2. The **ITEM NUMBER** corresponds to the item number shown for the part in illustration. Parts with item number preceded by a dash (such as: -1, -5, -12 etc.) are not illustrated.

3. **PART NUMBERS** that carry a **REED** part number.



# TRAILER MOUNTED PUMP MODEL B50 HOW TO USE PART MANUAL

**B50**  
**PARTS**  
**GROUP 00**  
**FIGURE 01**  
**PAGE 02**

2

3

4

5

1



## SINGLE SHIFT SWING VALVE ASSEMBLY

01 B50  
PARTS  
GROUP 60  
FIGURE 03  
PAGE 02

ITEM NO.	REED'S PART NO.	DESCRIPTION					QTY
		1	2	3	4	5	
-1	60-03	Assembly, Single Shift Swing Valve (See Group 60, Figure 01 for NHA)					Ref
-2	86321	• Assembly, Outlet Group					1
3		• • Nut					6
4	72482	• • Outlet, Machine 5"					1
5		• • Fitting, Grease					2
6	79895	• • Kit, Outlet Seal					1
7	77761	• • • O-Ring, Large					1
8	77762	• • • O-Ring, Small					1
9	86504	• • • Seal, Modified Outlet Thick					1
10	77763	• • • Band, Guide					1
11	77765	• • • Seal, Outlet, Thick					1
12	72309	• • Housing, Outlet Seal					1
13		• • Bolt, Hex					6
14		• • Nut, Nylock (attaching parts)					6
15		• • Washer, Lock (attaching parts)					6
16	70042	• • Outlet, Chromed					1
17		• • Bolt, Hex (attaching parts)					6
-18	86317	• Assembly, Swing Tube Group					1
19	85965	• • Weldment, Harsh Swing Tube					1
20	86085	• • Seal, 6 Inch Single Lip					1
21	72310	• • Ring, 6 Inch Single Lip Wear					1
22	86031	• • Plate, Wear					1
23	86086	• • Ring, Anti Chip					2
24		• • Bolt, Flat Head					4
25		• • Washer, Lock					4
26		• • Nut, Hex					4
27		• • Bolt, Hex					6
28		• • Washer, Lock					6
29	85962	• • Seal, Flange Bearing					1
30		• • Pin, Dowel					1
31		• • Fitting, Grease 90					2
32	85133	• • Bearing, 3 Inch Spline Flange					1
33	85294	• • Washer, Thrust					1
34	85134	• • Spacer, Swing Tube Nut					1
35	70825	• • Nut, Swing Tube					1
36		• • Pin, Cotter					1
-37	86319	• Assembly, Swing Tube Single Shift Group					1
38		• • Bolt, Hex					1
39		• • Washer, Flat					1
40		• • Washer, Lock					1
41	85131	• • Crank, 3 Inch Single Splined Bell					1

Continued On Next Page

REVISION:

2

3

4

5

REVISION:



# TRAILER MOUNTED PUMP MODEL B50 HOW TO USE PART MANUAL

**B50**  
**PARTS**  
GROUP 00  
FIGURE 01  
PAGE 03

2

3

4

5

1



## SINGLE SHIFT SWING VALVE ASSEMBLY

01 B50  
PARTS  
GROUP 60  
FIGURE 03  
PAGE 02

ITEM NO.	REED'S PART NO.	DESCRIPTION					QTY
		1	2	3	4	5	
-1	60-03	Assembly, Single Shift Swing Valve (See Group 60, Figure 01 for NHA)					Ref
-2	86321	• Assembly, Outlet Group					1
3		• • Nut					6
4	72482	• • Outlet, Machine 5"					1
5		• • Fitting, Grease					2
6	79895	• • Kit, Outlet Seal					1
7	77761	• • • O-Ring, Large					1
8	77762	• • • O-Ring, Small					1
9	86504	• • • Seal, Modified Outlet Thick					1
10	77763	• • • Band, Guide					1
11	77765	• • • Seal, Outlet, Thick					1
12	72309	• • Housing, Outlet Seal					1
13		• • Bolt, Hex					6
14		• • Nut, Nylock (attaching parts)					6
15		• • Washer, Lock (attaching parts)					6
16	70042	• • Outlet, Chromed					1
17		• • Bolt, Hex (attaching parts)					6
-18	86317	• Assembly, Swing Tube Group					1
19	85965	• • Weldment, Harsh Swing Tube					1
20	86085	• • Seal, 6 Inch Single Lip					1
21	72310	• • Ring, 6 Inch Single Lip Wear					1
22	86031	• • Plate, Wear					1
23	86086	• • Ring, Anti Chip					2
24		• • Bolt, Flat Head					4
25		• • Washer, Lock					4
26		• • Nut, Hex					4
27		• • Bolt, Hex					6
28		• • Washer, Lock					6
29	85962	• • Seal, Flange Bearing					1
30		• • Pin, Dowel					1
31		• • Fitting, Grease 90					2
32	85133	• • Bearing, 3 Inch Spline Flange					1
33	85294	• • Washer, Thrust					1
34	85134	• • Spacer, Swing Tube Nut					1
35	70825	• • Nut, Swing Tube					1
36		• • Pin, Cotter					1
-37	86319	• Assembly, Swing Tube Single Shift Group					1
38		• • Bolt, Hex					1
39		• • Washer, Flat					1
40		• • Washer, Lock					1
41	85131	• • Crank, 3 Inch Single Splined Bell					1

Continued On Next Page

REVISION:

2

3

4

5

REVISION:



## TRAILER MOUNTED PUMP MODEL *B50* HOW TO USE PART MANUAL

*B50*  
**PARTS**  
GROUP 00  
FIGURE 01  
PAGE 04

### 4. DESCRIPTION

**A.** The **INDENTURE SYSTEM** used in the parts list shows the relationship of one part to another. For a given item, the number of indentures depicts the relationship of the item to the components of the item as follows:

1 2 3 4 5

Assembly (or Installation)

- **Detail** part of assembly
- **Subassembly**
- **Attaching** parts for subassembly
  - **Detail** part of subassembly
  - **Sub-sub-assembly**
  - **Attaching** parts for sub-sub-assembly
    - **Detail** part of sub-sub-assembly
    - **Sub-sub-sub-assembly**
    - **Attaching** parts of sub-sub-sub-assembly
    - **Detail** part of sub-sub-sub-assembly

**B.** “See Group 60, Figure 02 for **NHA**”

Identifies the illustrated parts chapter location; indicates where the Next Higher Assembly (NHA) of the item shown.

**C.** “See Group 60, Figure 07 For **DET**”

Identifies the illustrated parts chapter location; indicates where the item and its Detailed Breakdown (DET) is shown.

**D.** “See Group 30, Figure 05 for **REF**” or “See Vendor Chapter For **REF**”

Identifies the illustrated parts chapter where the part is, and if listed and illustrated in Vendor Chapter. It is used as a cross-reference (**REF**).

### 5. QUANTITY

**A.** Reference (**REF**) indicates the item that is listed previously in the Next Higher Assembly (**NHA**) and then again in this figure.

**B.** As Required (**A/R**) indicates the part and required quantity as required.

**C.** A number entry indicates the quantity of the part used in its next higher application.

6. Functionally related assemblies are illustrated in phantom (— — — —) but not listed on the detail parts list page.

1. Always give serial number and model of **REED** trailer mounted concrete pump Model **B50**. (Refer to each unit name plate shown below). NOTE: This manual is being released to cover unit starting with serial number **3-05-1-2253** to current production. Some components used on earlier units differ from current productions. Where this occurs, the part is identified by a serial number.

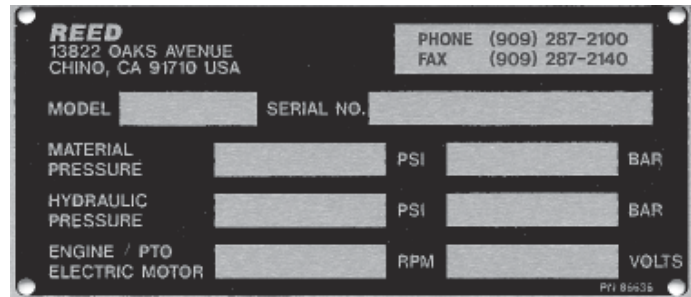

2. Always specify part number and complete name of parts ordered.

- A. Turn to table of contents in the desired installation. Refer to main group in which part should be listed.
- B. Find title of figure in which the part should be shown. Note figure number.

**REED** TRAILER MOUNTED PUMP 01 MODEL B50 GROUP 60 PUMPING TRAIN INSTALLATION

01 B50 PARTS GROUP 60 FIGURE 00 PAGE 01

REED TRAILER MOUNTED CONCRETE PUMP 01 MODEL B50 ILLUSTRATED PARTS MANUAL GROUP 60 PUMPING TRAIN INSTALLATION CONTAINS THE FOLLOWING FIGURES:

- FIGURE 00 TABLE OF CONTENTS
- FIGURE 01 SINGLE SHIFT PUMPING TRAIN INSTALLATION
- FIGURE 02 DUAL SHIFT PUMPING TRAIN INSTALLATION
- FIGURE 03 SINGLE SHIFT SWING VALVE ASSEMBLY
- FIGURE 04 DUAL SHIFT SWING VALVE ASSEMBLY
- FIGURE 05 SINGLE SHIFT SWING RAM CYLINDER SUBASSEMBLY
- FIGURE 06 DUAL SHIFT SWING RAM CYLINDER SUBASSEMBLY
- FIGURE 07 MATERIAL CYLINDER ASSEMBLY
- FIGURE 08 FLUSHBOX ASSEMBLY
- FIGURE 09 HYDRAULIC DRIVE CYLINDER ASSEMBLY
- FIGURE 10 HYDRAULIC DRIVE CYLINDER SUBASSEMBLIES

REVISION:





# TRAILER MOUNTED PUMP MODEL B50 HOT TO ORDER PARTS

**B50**  
**PARTS**  
**GROUP 00**  
**FIGURE 02**  
**PAGE 02**



## SINGLE SHIFT SWING VALVE ASSEMBLY

01 B50  
PARTS  
GROUP 60  
FIGURE 03  
PAGE 01

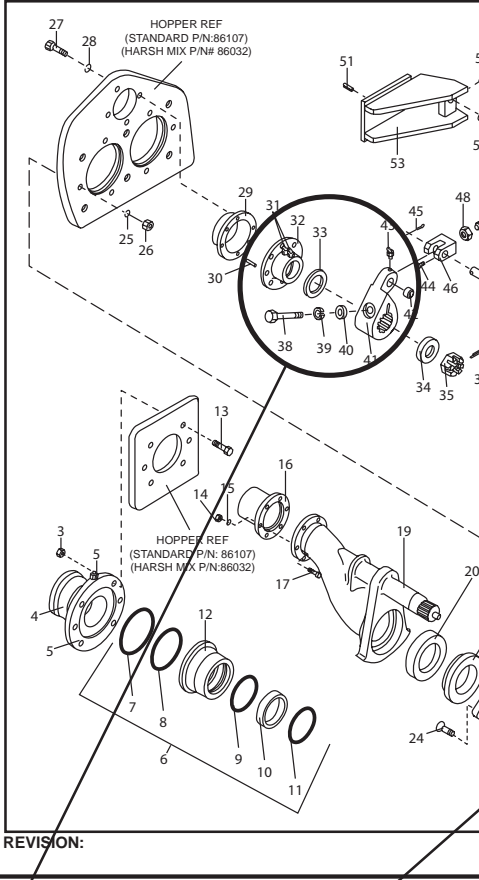

## DUAL SHIFT SWING VALVE ASSEMBLY

01 B50  
PARTS  
GROUP 60  
FIGURE 04  
PAGE 02

ITEM NO.	REED'S PART NO.	DESCRIPTION					QTY
		1	2	3	4	5	
-1	60-04	Assembly, Single Shift Swing Valve (See Group 60, Figure 02 for NHA)					Ref
-2	86321	• Assembly, Outlet Group					1
3		• Nut					6
4	72482	• Outlet, Machine 5"					1
5		• Fitting, Grease					2
6	79895	• Kit, Outlet Seal					1
7	77761	• O-Ring, Large					1
8	77762	• O-Ring, Small					1
9	86504	• Seal, Modified Outlet Thick					1
10	77763	• Band, Guide					1
11	77765	• Seal, Outlet, Thick					1
12	72309	• Housing, Outlet Seal					1
13		• Bolt, Hex					6
14		• Nut, Nylock (attaching parts)					6
15		• Washer, Lock (attaching parts)					6
16	70042	• Outlet, Chromed					1
17		• Bolt, Hex (attaching parts)					6
-18	86317	• Assembly, Swing Tube Group					1
19	85965	• Weldment, Harsh Swing Tube					1
20	86085	• Seal, 6 Inch Single Lip					1
21	72310	• Ring, 6 Inch Single Lip Wear					1
22	86031	• Plate, Wear					1
23	86086	• Ring, Anti Chip					2
24		• Bolt, Flat Head					4
25		• Washer, Lock					4
26		• Nut, Hex					4
27		• Bolt, Hex					6
28		• Washer, Lock					6
29	85962	• Seal, Flange Bearing					1
30		• Pin, Dowel					1
31		• Fitting, Grease 90					2
32	86186	• Bearing, 3 Inch Spine Flange					4
33	85294	• Washer, Thrust					1
34	86184	• Spacer, Swing Tube Nut					1
35	70825	• Nut, Swing Tube					1
36		• Pin, Cotter					1
-37	86320	• Assembly, Swing Tube Dual Shift Group					1
38		• Plug, Pipe					4
39	86052	• Pin, Spring					4
40		• Fitting, Grease 90					2
41	86441	• Retainer, Swing Ram					2

DASH (-) ITEM NOT ILLUSTRATED

REVISION:

- C. Turn to corresponding page, find the group and figure.
- D. Check your required part and its attaching parts and match with illustration page.
- E. Refer to corresponding item number in the part list page. Part numbers are located in the part number column.
- F. When ordering variable or optional miscellaneous parts which are not found in this parts chapter, follow the above outlined procedure of how to order parts.
  - 1) When applicable, give model and serial number of the component for which parts are desired.
  - 2) In a specific, difficult to describe situation, a marked-up photograph or detailed sketch would be helpful.

REVISION:



## TRAILER MOUNTED PUMP MODEL *B50* HOW TO ORDER PARTS

*B50*  
PARTS  
GROUP 00  
FIGURE 02  
PAGE 03

3. Do not designate quantity by "set." State specifically how many parts are wanted.
4. Always give complete address and full shipping instructions. Specify shipping instructions, truck freight, air freight. United Parcel Service (UPS), or FedEx and DHL are available in designated areas.

### 5. TO ORDER

#### A. BY MAIL

Attention: Parts Department  
**REED**  
13822 Oaks Avenue  
Chino, CA. 91710

#### B. BY FAX

(909) 287 - 2141

#### C. BY PHONE

(909) 287 - 2100

6. Part return without authorization will not be accepted. If it is necessary to return parts for any reason, written authorization may be obtained from **REED** Parts Department, Chino, CA. 91710. A Parts Return Authorization form is provided when **REED** deems its necessary to have the part returned for evaluation. The form is issued by the Warranty of Parts Department of **REED**.
  - A. The form will be filled by **REED** unless requesting necessary information and you will receive a copy as well as shipping tag.
  - B. Attach shipping tag to part insert return original invoice.
  - C. Ship part to **REED** PREPAID.
  - D. Part must be returned to **REED** within 30 days from date of authorization.

REVISION:

**REED** TRAILER MOUNTED CONCRETE PUMP MODEL *B50* ILLUSTRATED PARTS MANUAL GROUP 10 FINAL INSTALLATION CONTAINS THE FOLLOWING FIGURES:

- FIGURE 00** TABLE OF CONTENTS
- FIGURE 01** STANDARD HOPPER WITH SINGLE SHIFT INSTALLATION
- FIGURE 02** STANDARD HOPPER WITH DUAL SHIFT INSTALLATION
- FIGURE 03** DECAL ASSEMBLY



**SHOWN MODEL STANDARD HOPPER WITH  
DUAL SHIFT SWING CYLINDER UNIT**



# STANDARD HOPPER WITH SINGLE SHIFT FINAL INSTALLATION

**B50**  
**PARTS**  
GROUP 10  
FIGURE 01  
PAGE 01

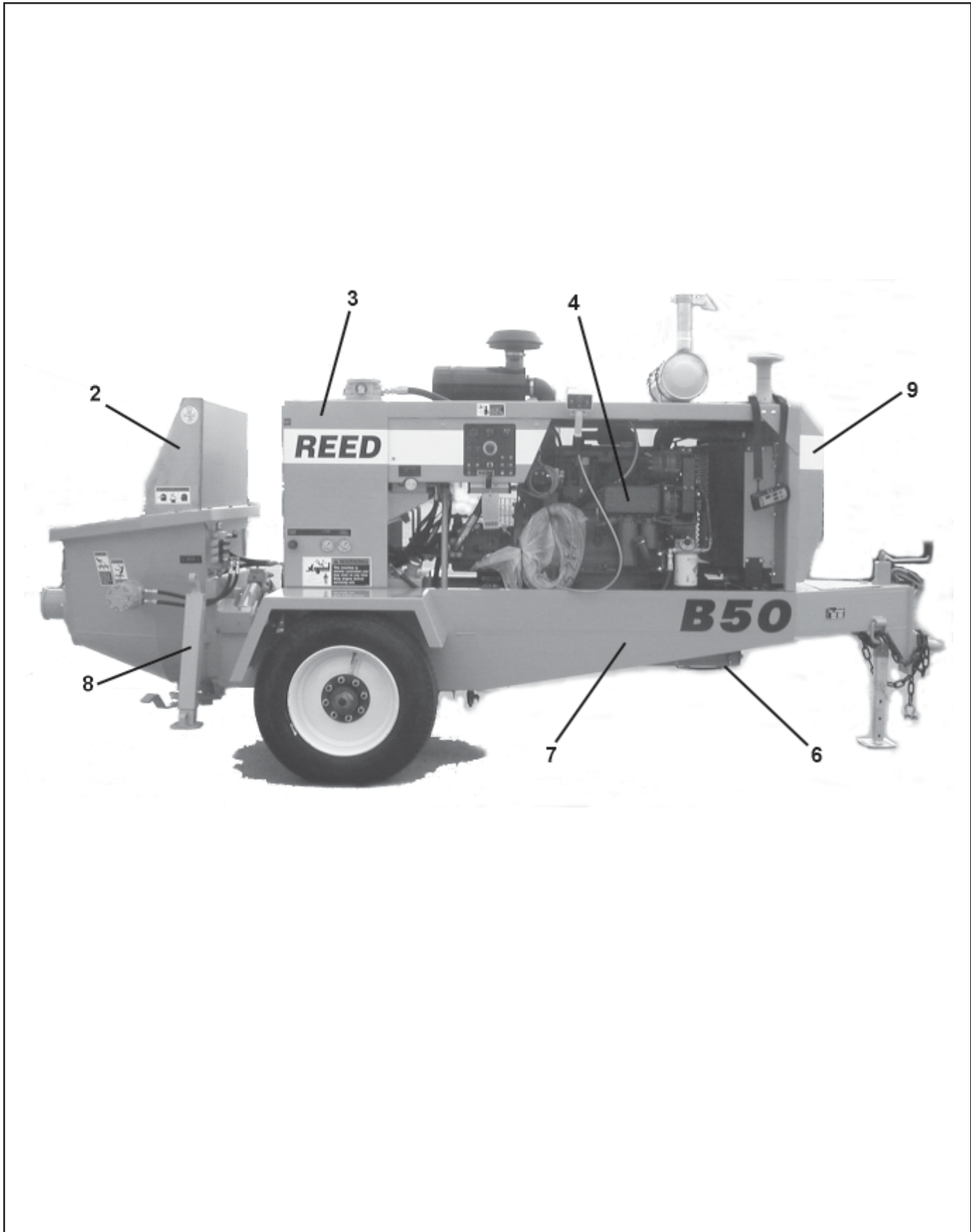

REVISION:



# STANDARD HOPPER WITH SINGLE SHIFT FINAL INSTALLATION

**B50**  
**PARTS**  
GROUP 10  
FIGURE 01  
PAGE 02

ITEM NO.	REED'S PART NO.	DESCRIPTION					QTY
		1	2	3	4	5	
-1	<b>B50A-V04</b>	Installation, <b>B50</b> Standard Hopper with Single Shift Final					<b>Ref</b>
2	20-01	• Installation, Standard Hopper (See Group 20, Figure 01 for DET)					1
3	30-01	• Installation, Tank (See Group 30, Figure 01 for DET)					1
4	40-01	• Installation, Power Train (See Group 40, Figure 01 for DET)					1
5	50-01	• Installation Control (See Group 50 Figure 01 for DET)					1
6	60-01	• Installation, Single Shift Pumping Train (See Group 60, Figure 01 for DET)					1
7	70-01	• Installation, Frame (See Group 70, Figure 01 for DET)					1
8	80-01	• Installation, Optional (See Group 80, Figure 01 for DET)					1
9	10-05	• Kit, <b>B50</b> Decal (See Group 10, Figure 05 for DET)					1

DASH (-) ITEM NOT ILLUSTRATED

REVISION:



**STANDARD HOPPER WITH DUAL  
SHIFT FINAL INSTALLATION**

**B50  
PARTS  
GROUP 10  
FIGURE 02  
PAGE 01**

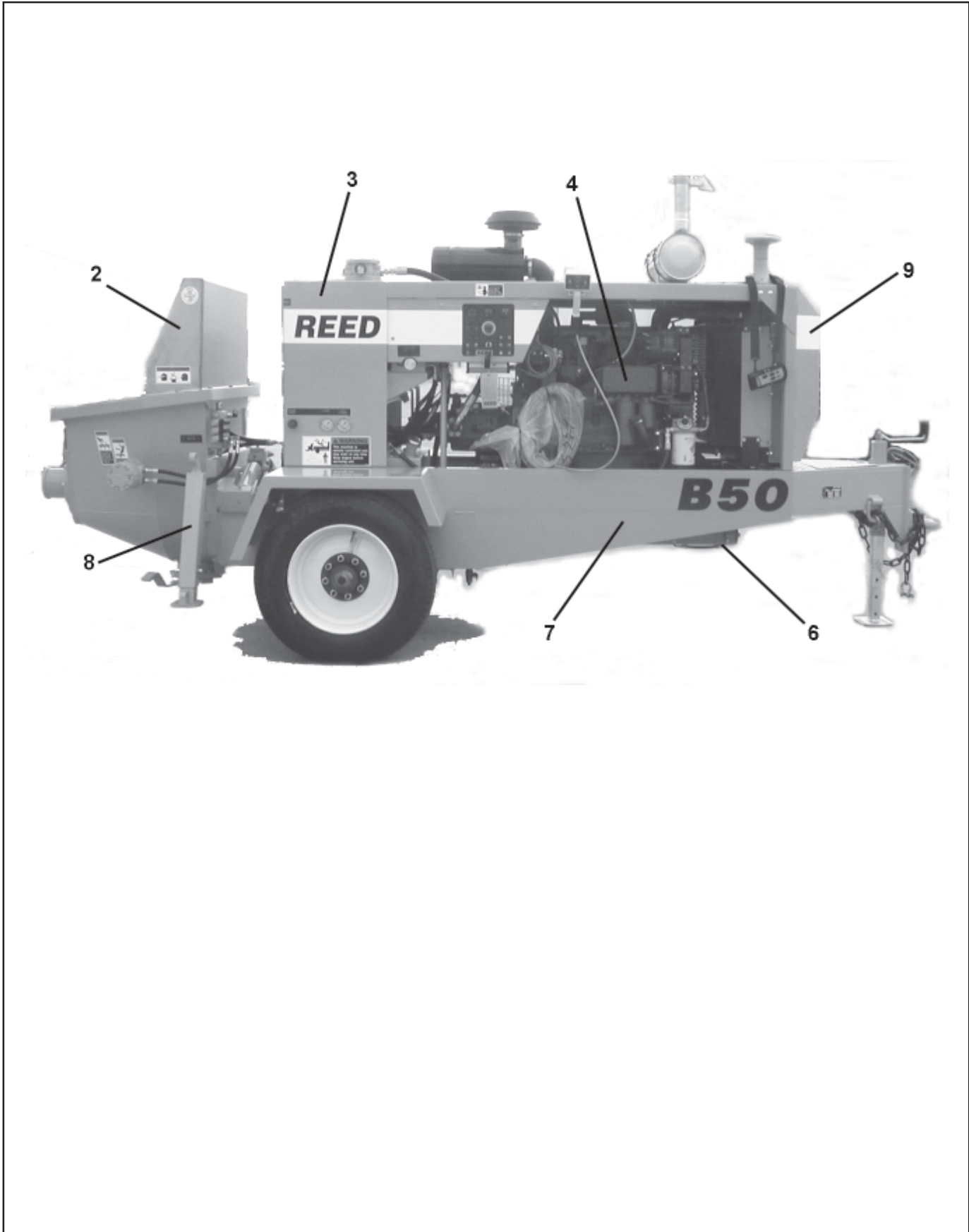

REVISION:



## STANDARD HOPPER WITH DUAL SHIFT FINAL INSTALLATION

**B50**  
**PARTS**  
GROUP 10  
FIGURE 02  
PAGE 02

ITEM NO.	REED'S PART NO.	DESCRIPTION					QTY
		1	2	3	4	5	
-1	<b>B50C-V04</b>	Installation, <b>B50</b> Standard Hopper with Dual Shift Final					<b>Ref</b>
2	20-01	• Installation, Standard Hopper (See Group 20, Figure 01 for DET)					1
3	30-01	• Installation, Tank (See Group 30, Figure 01 for DET)					1
4	40-01	• Installation, Power Train (See Group 40, Figure 01 for DET)					1
5	50-01	• Installation Control (See Group 50 Figure 01 for DET)					1
6	60-02	• Installation, Dual Shift Pumping Train (See Group 60, Figure 02 for DET)					1
7	70-01	• Installation, Frame (See Group 70, Figure 01 for DET)					1
8	80-01	• Installation, Optional (See Group 80, Figure 01 for DET)					1
9	10-05	• Kit, <b>B50</b> Decal (See Group 10, Figure 05 for DET)					1

DASH (-) ITEM NOT ILLUSTRATED

REVISION:

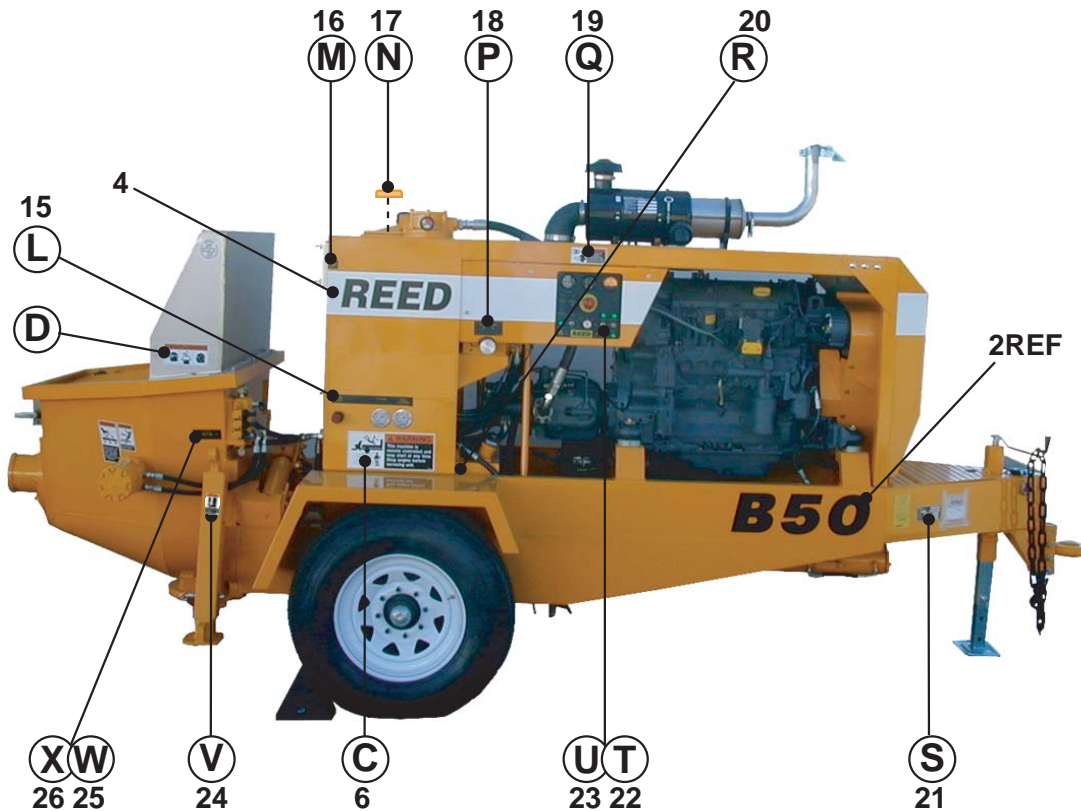
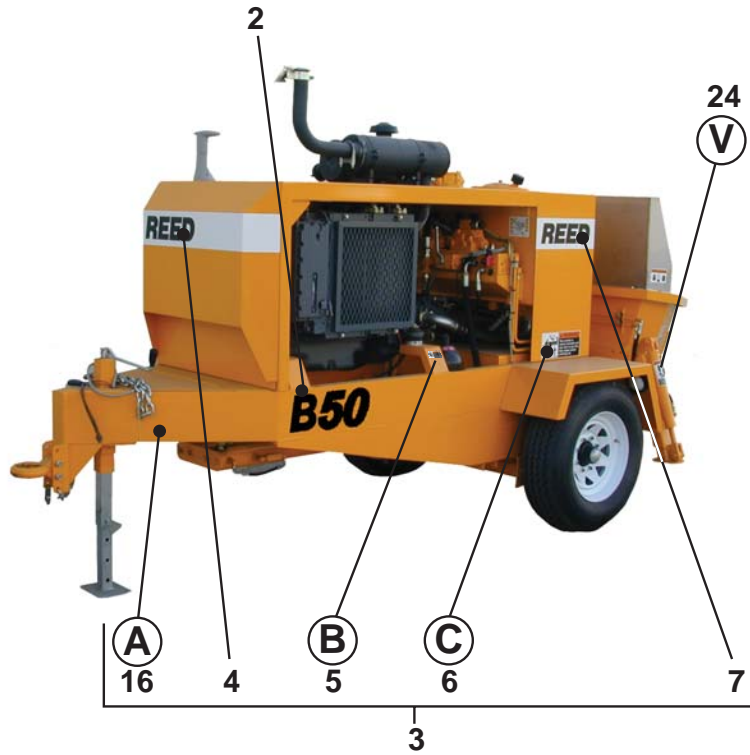

**A**

SHOWN MODEL HARSH MIX HOPPER WITH  
DUAL SHIFT SWING CYLINDER UNIT





## DECAL ASSEMBLY

**B50**  
**PARTS**  
GROUP 10  
FIGURE 05  
PAGE 02



ITEM NO.	REED'S PART NO.	DESCRIPTION					QTY
		1	2	3	4	5	
-1	10-05	Kit, <b>B50</b> Decal (See Group 10, Figure 01, 02, 03, and 04 for NHA)					Ref
2	86703	• Decal, <b>B50</b> 6 Inch Black					2
3	85425	• Kit, B-Series Decal					1
4	85418	•• Decal, <b>REED</b> 4-1/2 Inch Black and White 48 Inch					2
5	800916	•• Decal, Warning, Keep Hand Out of Water Box					1
6	800924	•• Decal, Warning, This Machine is Remote Controlled...					2
7	85416	•• Decal, <b>REED</b> 4-1/2 Inch Black and White 20 Inch					1
8	800922	•• Decal, Warning, Before Opening a Blocked Pipeline					1
9	800921	•• Decal, Warning, Do Not Operate at Pressures...					1
10	73132	•• Decal, <b>REED</b> 4-1/2 Inch					1
11	800931	•• Decal, <b>ACPA</b> Member					1
12	800929A	•• Decal, Warning					2
13	800917	•• Decal, Warning, Keep Hand Out of Hopper and Valve					2
14	800918	•• Decal, Warning, Do Not Stand on Hopper Grate					2
15	85684	•• Decal, B-Series Gauge					1
16	85844	•• Decal, Oil					1
17	75020	•• Decal, Hydraulic Oil					1
18	85413	•• Decal, Volume Control					1
19	800926	•• Decal, Warning, Do Not Operate This Machine without					1
20	75017	•• Decal, Diesel Fuel Only					1
21	86636	•• Nameplate, <b>REED</b> , Serial No.					1
22	85332	• Decal, <b>B50</b> Control Box Panel					1
23	85410	• Decal, <b>B50</b> Remote Control					1
24	800919	• Decal, Optional, Warning, Stand Clear Outriggers When					2
25	83845	• Decal, Outriggers (Optional Items)					1
26	83846	• Decal, Agitator (Optional Items)					1

DASH (-) ITEM NOT ILLUSTRATED

REVISION:

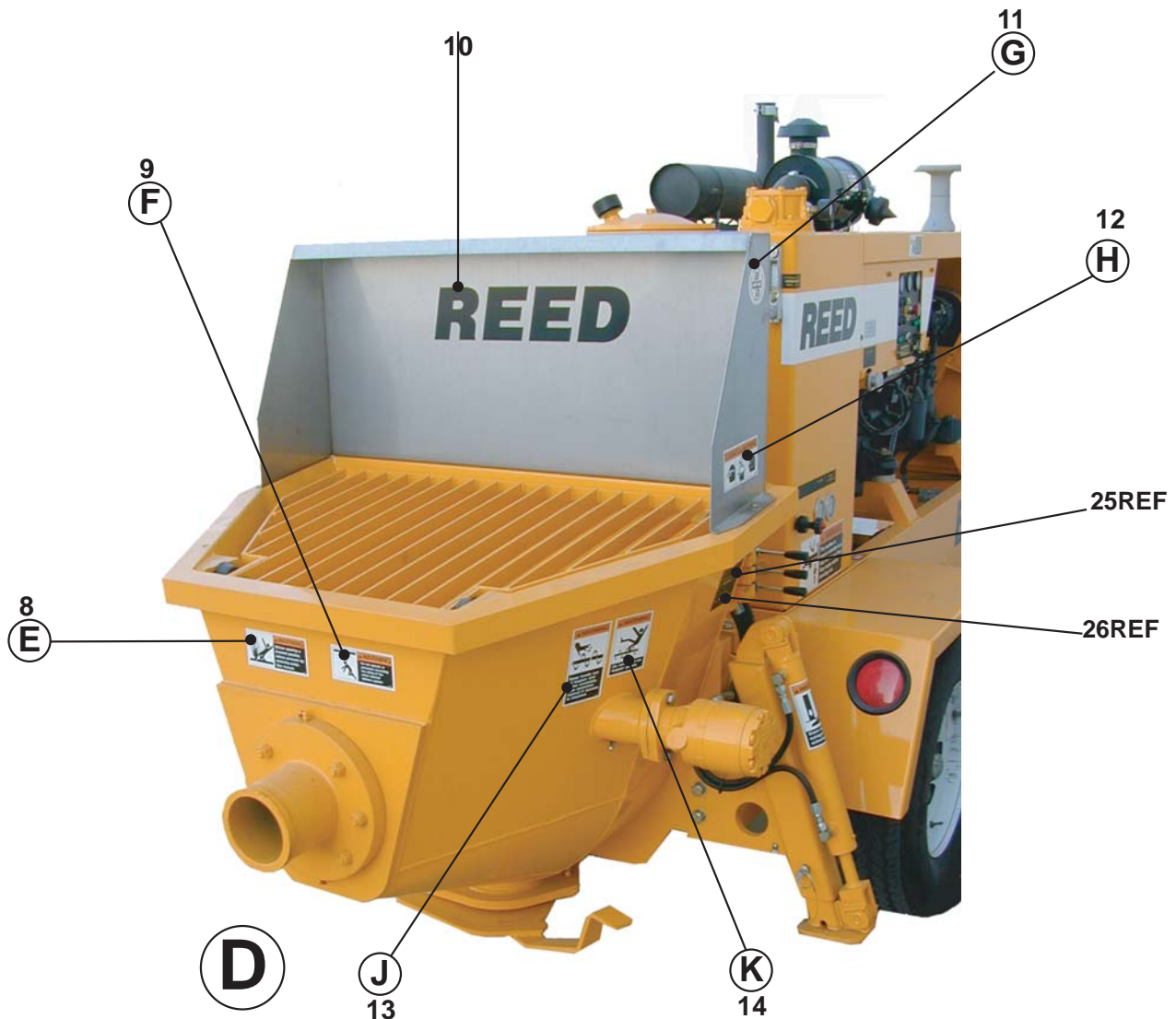

SHOWN MODEL  
HARSH MIX HOPPER UNIT



### ⚠ WARNING

Before opening a blocked pipeline, relieve pressure by reversing pump. See manual.

800922

6



9



### ⚠ WARNING

Do not operate at pressures exceeding the rating of the entire material delivery system.

### ⚠ ADVERTENCIA

No utilizar a presiones que excedan la presión nominal de todo el material de la línea de entrega.

800921

Do not paint over this label/No pintar encima de ésta etiqueta



## CUIDADO ⚠ WARNING



800929A



12

11





**J**

13



**K**

14

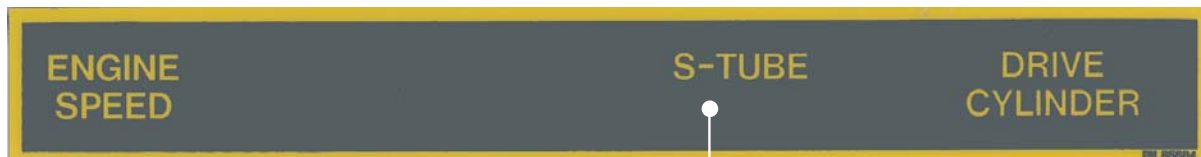

**L**

15

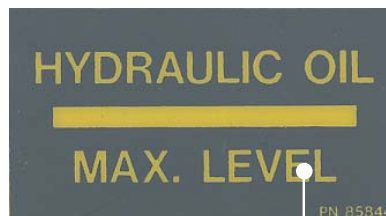

**M**

16



# DECAL ASSEMBLY

B50  
PARTS  
GROUP 10  
FIGURE 05  
PAGE 06

**HYDRAULIC OIL**

(N)

17

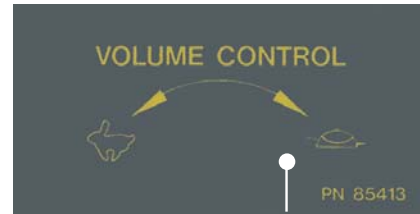

(P)

18



(Q)

19

**DIESEL FUEL  
ONLY**

(R)

20

<b>REED</b> 13822 OAKS AVENUE CHINO, CA 91710 USA		PHONE (909) 287-2100 FAX (909) 287-2140		
MODEL	_____	SERIAL NO.	_____	
MATERIAL PRESSURE	_____	PSI	_____	BAR
HYDRAULIC PRESSURE	_____	PSI	_____	BAR
ENGINE / PTO ELECTRIC MOTOR	_____	R	_____	VOLTS

PN 85413

(S)

21

REVISION:

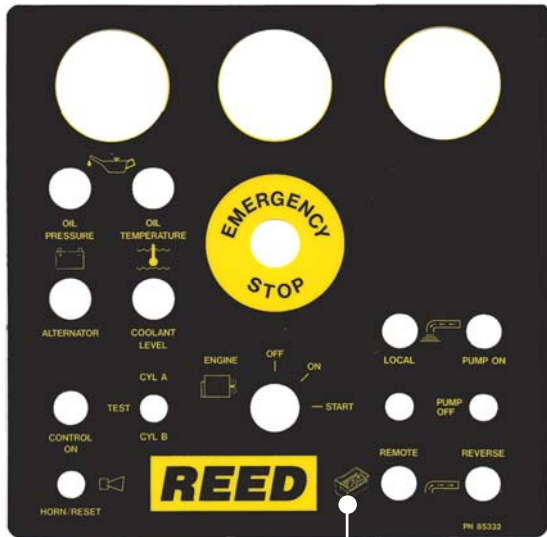

**T** 22

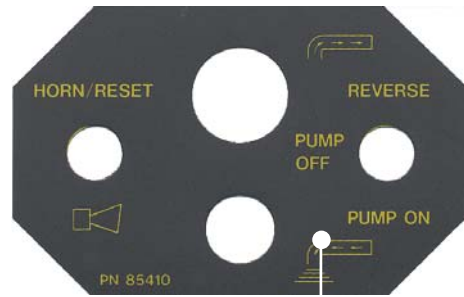

**U** 23



**W** 25



**V** 24



## DECAL ASSEMBLY

**B50**  
**PARTS**  
GROUP 10  
FIGURE 05  
PAGE 08

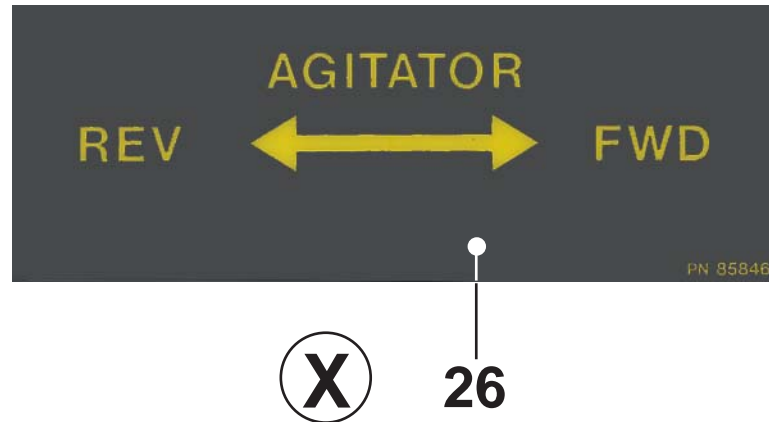

ITEM NO.	REED'S PART NO.	DESCRIPTION					QTY
		1	2	3	4	5	
-1	10-05	Kit, <b>B50</b> Decal (See Group 10, Figure 01, 02, 03, and 04 for NHA)					Ref
2	86703	• Decal, <b>B50</b> 6 Inch Black					2
3	85425	• Kit, B-Series Decal					1
4	85418	•• Decal, <b>REED</b> 4-1/2 Inch Black and White 48 Inch					2
5	800916	•• Decal, Warning, Keep Hand Out of Water Box					1
6	800924	•• Decal, Warning, This Machine is Remote Controlled...					2
7	85416	•• Decal, <b>REED</b> 4-1/2 Inch Black and White 20 Inch					1
8	800922	•• Decal, Warning, Before Opening a Blocked Pipeline					1
9	800921	•• Decal, Warning, Do Not Operate at Pressures...					1
10	73132	•• Decal, <b>REED</b> 4-1/2 Inch					1
11	800931	•• Decal, <b>ACPA</b> Member					1
12	800929A	•• Decal, Warning					2
13	800917	•• Decal, Warning, Keep Hand Out of Hopper and Valve					2
14	800918	•• Decal, Warning, Do Not Stand on Hopper Grate					2
15	85684	•• Decal, B-Series Gauge					1
16	85844	•• Decal, Oil					1
17	75020	•• Decal, Hydraulic Oil					1
18	85413	•• Decal, Volume Control					1
19	800926	•• Decal, Warning, Do Not Operate This Machine without					1
20	75017	•• Decal, Diesel Fuel Only					1
21	86636	•• Nameplate, <b>REED</b> , Serial No.					1
22	85332	• Decal, <b>B50</b> Control Box Panel					1
23	85410	• Decal, <b>B50</b> Remote Control					1
24	800919	• Decal, Optional, Warning, Stand Clear Outriggers When					2
25	83845	• Decal, Outriggers (Optional Items)					1
26	83846	• Decal, Agitator (Optional Items)					1

DASH (-) ITEM NOT ILLUSTRATED

REVISION:



**TRAILER MOUNTED PUMP MODEL *B50*  
ILLUSTRATED PARTS MANUAL**

***B50*  
PARTS  
GROUP 10  
FIGURE 06  
PAGE 01**

THIS PAGE INTENTIONALLY LEFT BLANK





## TRAILER MOUNTED PUMP MODEL *B50* GROUP 20 HOPPER INSTALLATION

*B50*  
PARTS  
GROUP 20  
FIGURE 00  
PAGE 01

**REED** TRAILER MOUNTED CONCRETE PUMP MODEL *B50* ILLUSTRATED PARTS MANUAL GROUP 20 HOPPER INSTALLATION CONTAINS THE FOLLOWING FIGURES:

- FIGURE 00** TABLE OF CONTENTS
- FIGURE 01** STANDARD HOPPER INSTALLATION-NO MIXER
- FIGURE 02** STANDARD HOPPER INSTALLATION-WITH MIXER
- FIGURE 03** HOPPER CLEAN OUT DOOR ASSEMBLY
- FIGURE 04** STANDARD HOPPER AGITATOR ASSEMBLY
- FIGURE 05** STANDARD HOPPER AGITATOR MOTOR ASSEMBLY
- FIGURE 06** 3 SPOOL CONTROL VALVE ASSEMBLY
- FIGURE 07** 3 SPOOL CONTROL VALVE SUBASSEMBLY



REVISION:



# STANDARD HOPPER INSTALLATION-NO MIXER

B50  
PARTS  
GROUP 20  
FIGURE 01  
PAGE 01

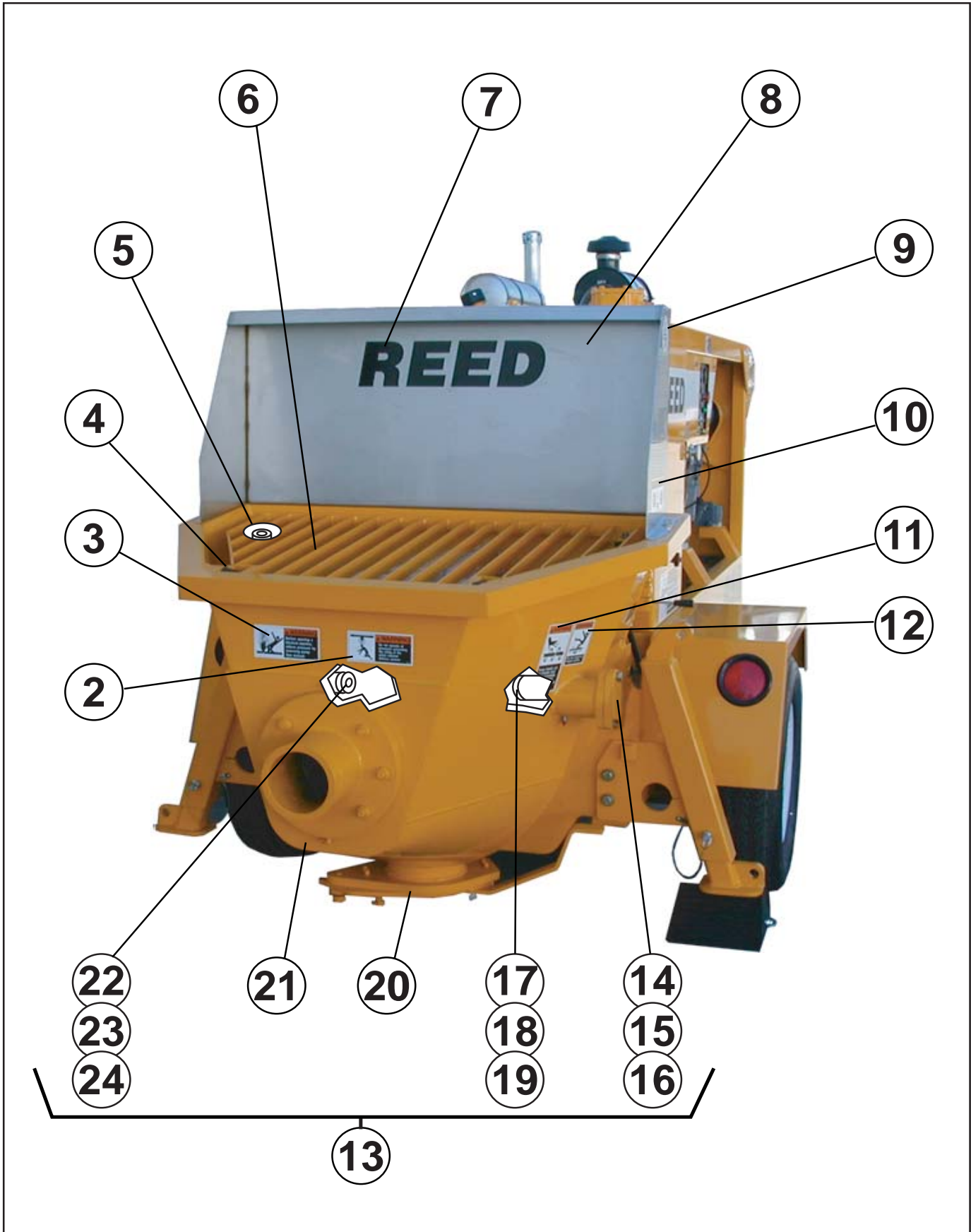

REVISION:



## STANDARD HOPPER INSTALLATION-NO MIXER

**B50**  
**PARTS**  
GROUP 20  
FIGURE 01  
PAGE 02

ITEM NO.	REED'S PART NO.	DESCRIPTION					QTY
		1	2	3	4	5	
-1	20-01	Installation, Standard Hopper-No Mixer (See Group 10, Figure 01 and Figure 02 for NHA)					Ref
2	800921	• Decal, Warning, Do Not Operate at Pressures...					1
3	800922	• Decal, Warning, Before Operating a Blocked Pipeline...					1
4	86118	• Mount, Hopper Grate					2
5	86083	• Bumper, Hopper Grate					2
6	86113	• Grate, Standard Hopper					1
7	73132	• Decal, <b>REED</b> 4-1/2 Inch					1
8	85390	• Guard, Splash					1
9	800931	• Decal, <b>ACPA</b> Member					1
10	800929A	• Decal, Warning					2
11	800918	• Decal, Warning, Do Not Stand on Hopper Grate					2
12	800917	• Decal, Warning, Keep Hand Out of Hopper and Valve					2
13	86313	• Assembly, Standard Hopper					1
14	73433	•• Cover, Remix Outside					1
15		•• Bolt, Hex (attaching parts)					2
16		•• Washer, SPL Lock (attaching parts)					2
17	73434	•• Cover, Remix Inside					1
18		•• Bolt, Hex (attaching parts)					6
19		•• Washer, SPL Lock (attaching parts)					6
20	86542	•• Assembly, Clean Out Door (See Group 20, Figure 03 for DET)					1
21	86107	•• Weldment, Standard Hopper					1
22	86623	•• Seal, Agitator					1
23		•• Bolt, Hex (attaching parts)					1
24		•• Washer, Flat (attaching parts)					1
-25	86322	• Assembly, Standard Hopper Agitator (Optional Item) (See Group 20, Figure 04 for DET)					1
-25	20-08	• Assembly, 3 Spool Control Valve (Optional Item) (See Group 20, Figure 08 for DET)					1

DASH (-) ITEM NOT ILLUSTRATED

REVISION:



# STANDARD HOPPER INSTALLATION-WITH MIXER

B50  
PARTS  
GROUP 20  
FIGURE 02  
PAGE 01

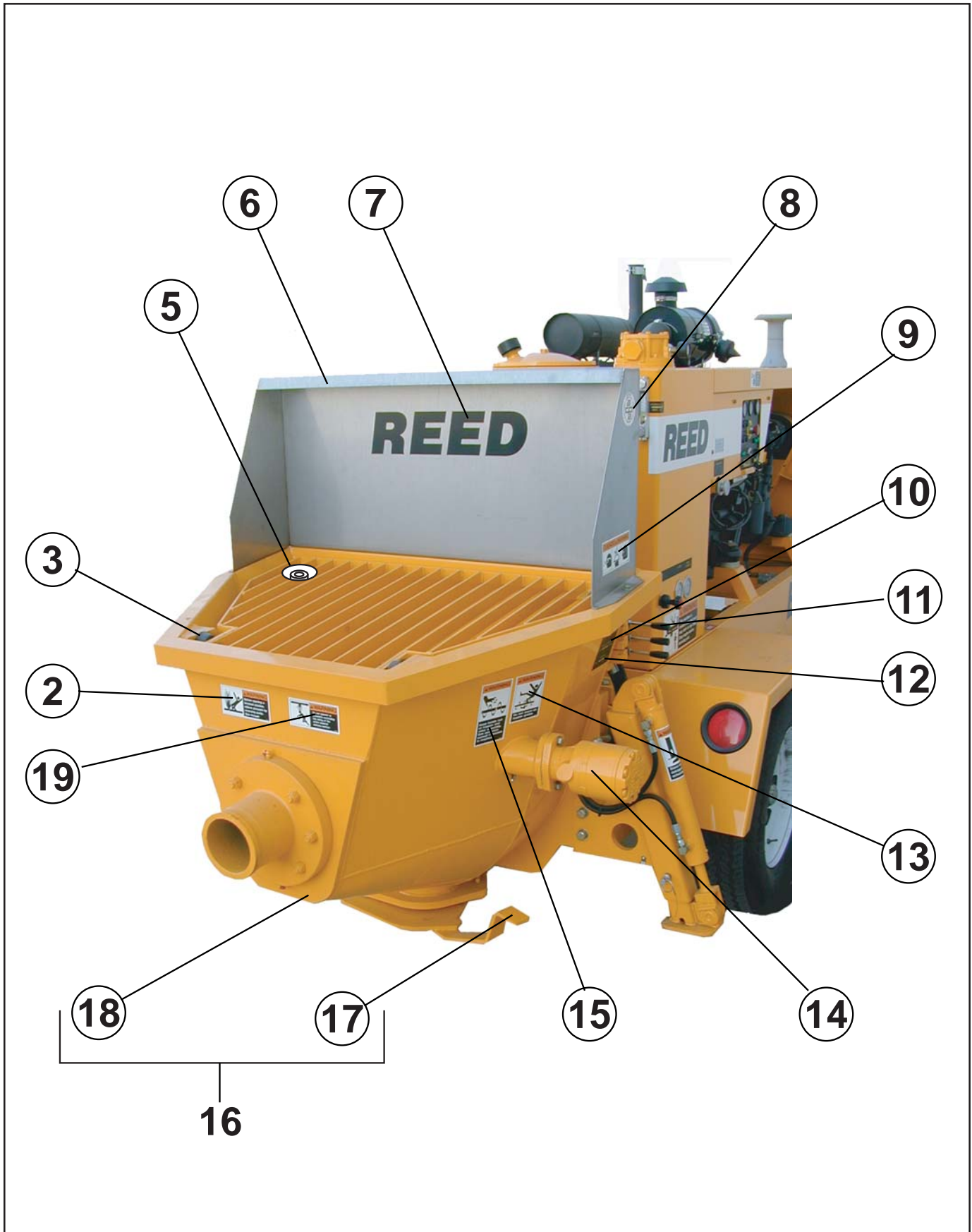

REVISION:



## STANDARD HOPPER INSTALLATION-WITH MIXER

**B50**  
**PARTS**  
GROUP 20  
FIGURE 02  
PAGE 02

ITEM NO.	REED'S PART NO.	DESCRIPTION					QTY
		1	2	3	4	5	
-1	20-02	Installation, Standard Hopper-With Mixer (See Group 10, Figure 03 and Figure 04 for NHA)					Ref
2	800922	• Decal, Warning, Before Opening a Blocked Pipeline					1
3	86118	• Mount, Hopper Grate					2
4	86113	• Grate, Standard Hopper					1
5	86083	• Bumper, Hopper Grate					2
6	85390	• Guard, Splash					1
7	73132	• Decal, <b>REED</b> 4-1/2 Inch					1
8	800931	• Decal, ACPA Member					1
9	800929A	• Decal, <b>Warning</b>					2
10	83845	• • Decal, Outriggers (Optional Items)					1
11	20-08	• Assembly, 3 Spool Control Valve (See Group 20, Figure 08 for DET)					1
12	83846	• Decal, Agitator					1
13	800917	• Decal, Warning, Keep Hand Out of Hopper and Valve					2
14	86322	• Assembly, Standard Hopper Agitator (Optional Item) (See Group 20, Figure 04 for DET)					1
15	800918	• Decal, Warning, Do Not Stand on Hopper Grate					2
16	86107	• Weldment, Standard Hopper					1
17	86542	• • Assembly, Clean Out Door (See Group 20, Figure 03 for DET)					1
18	86032	• • Weldment, Harsh Mix Hopper					1
19	800921	• Decal, Warning, Do Not Operate at Pressures Exceeding					1

DASH (-) ITEM NOT ILLUSTRATED

REVISION:



# HOPPER CLEAN OUT DOOR ASSEMBLY (ROUNDED)

B50  
PARTS  
GROUP 20  
FIGURE 03  
PAGE 01

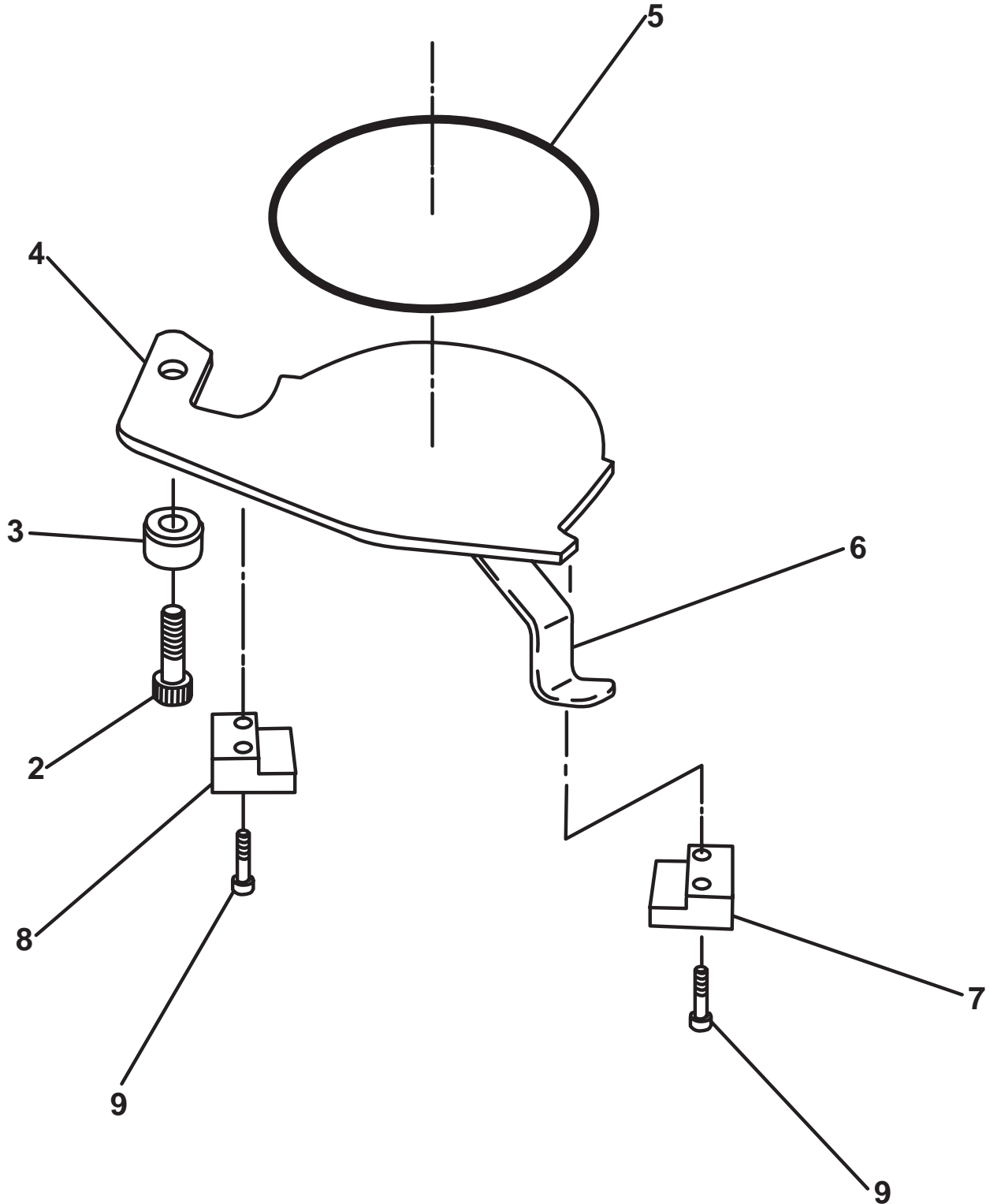

REVISION:



# ROUNDED CLEAN OUT DOOR ASSEMBLY

**B50**  
**PARTS**  
GROUP 20  
FIGURE 03  
PAGE 02

ITEM NO.	REED'S PART NO.	DESCRIPTION					QTY
		1	2	3	4	5	
-1	#86542	Assembly, Rounded Clean Out Door (See Group 20, Figure 01 and 02 for NHA)					Ref
2		• Bolt, Shoulder					1
3	85367	• Boss, Clean Out Door					1
4	86988	• Door, Clean Out					1
5	78142	• Assembly, 3 FT Cord					1
6	85369	• Handle, Clean Out Door					1
7	85313	• Block, Clean Out Door					2
8		• Capscrew, Socket Head					4
9	85368	• Bolt, Mod					2
10		• Nut, Jam					2
-11	85312	• Plate Seal					1
-12	85371	• Neck, Clean Out Door					1

DASH (-) ITEM NOT ILLUSTRATED

REVISION:

## STANDARD HOPPER AGITATOR ASSEMBLY

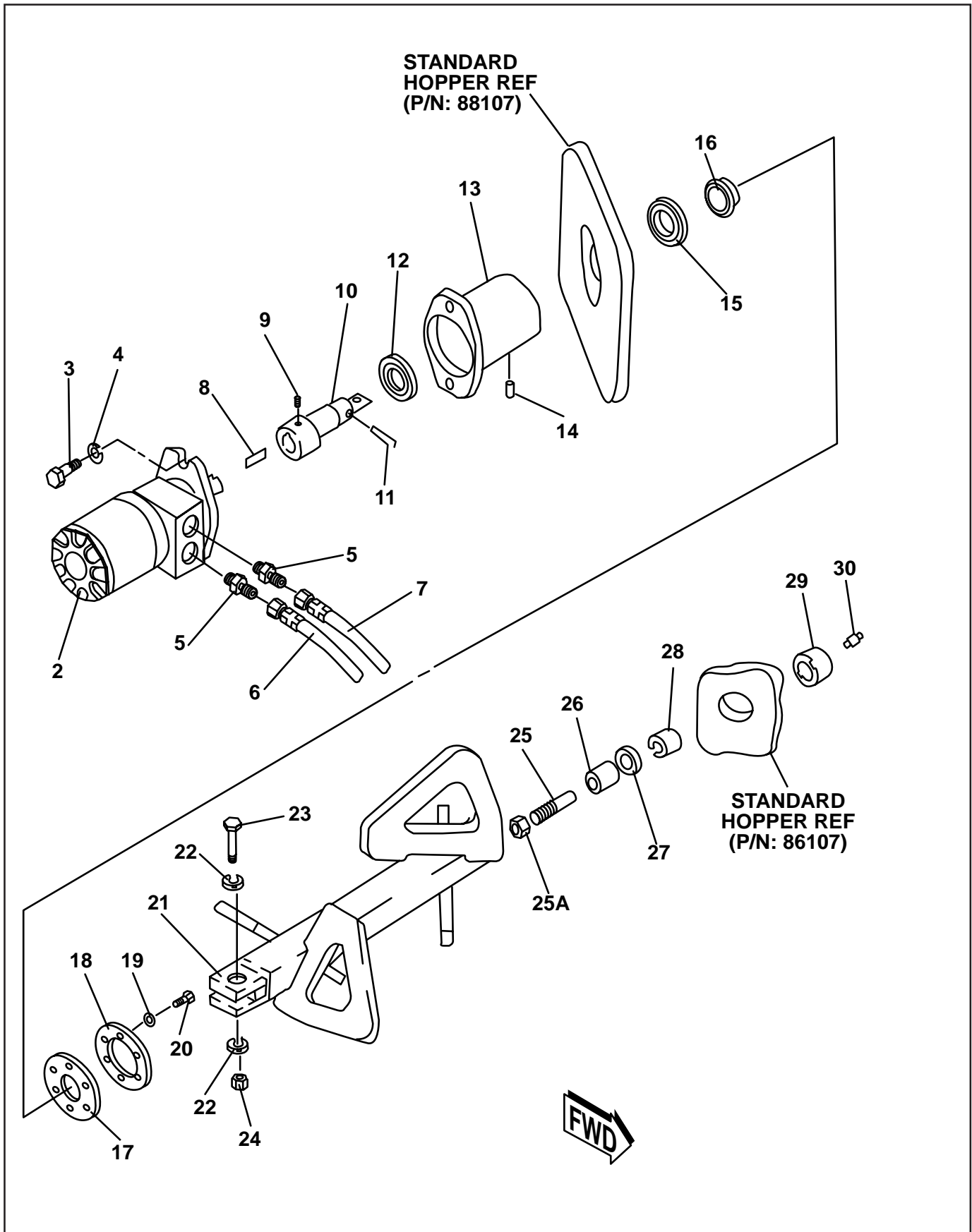





# STANDARD HOPPER AGITATOR ASSEMBLY

**B50**  
**PARTS**  
GROUP 20  
FIGURE 04  
PAGE 02

ITEM NO.	REED'S PART NO.	DESCRIPTION					QTY
		1	2	3	4	5	
-1	86322	Assembly, Standard Hopper Agitator (Optional Item) (See Group 20, Figure 01 for NHA)					Ref
2	85811	• Assembly, Standard Hopper Agitator Motor (See Group 20, Figure 06 for DET)					1
3		• Bolt, Hex (attaching parts)					2
4		• Washer, Lock (attaching parts)					2
5		• Fitting, STR					2
6	85658-010	• Assembly, Hose					1
7	85658-011	• Assembly, Hose					1
8	30216	• Key					1
9	80374	• Screw, Set					1
10	85923	• Shift, Agitator					1
11	86758	• Pin, Spring					1
12	85979	• Bearing, with Seal Ball					1
13	70226	• Housing, Bearing with Flange (Welded on Std. Hopper)					1
14	80516	• Fitting, 45 Grease					1
15	85978	• Bearing, Plain Ball					1
16	85976	• Ring, Agitator Wear					1
17	70212	• Seal					1
18	70211	• Flange, Seal					1
19	86743	• Washer, Lock (attaching parts)					6
20	86744	• Bolt, Hex (attaching parts)					6
21	86330	• Weldment, Standard Hopper Agitator Shaft					1
22		• Washer, Flat Washer 1/2"					2
23	86756	• Screw, Hex Head Cap (attaching parts)					1
24	80075	• Nut (attaching parts)					1
25	70214	• Shaft, Idle					1
25A	80030	• 20 MM Hex Lock Nut					1
26	77877	• Spacer					1
27	86186	• Washer					1
28	70219	• Bearing, Idler					1
29	70210	• Housing, Idler Bearing (Welded on Standard Hopper)					1
30		• Fitting, STR Grease					1
33		• Bolt, Hex (attaching parts)					1

DASH (-) ITEM NOT ILLUSTRATED

REVISION:



# STANDARD HOPPER AGITATOR MOTOR ASSEMBLY

**B50**  
**PARTS**  
GROUP 20  
FIGURE 05  
PAGE 01

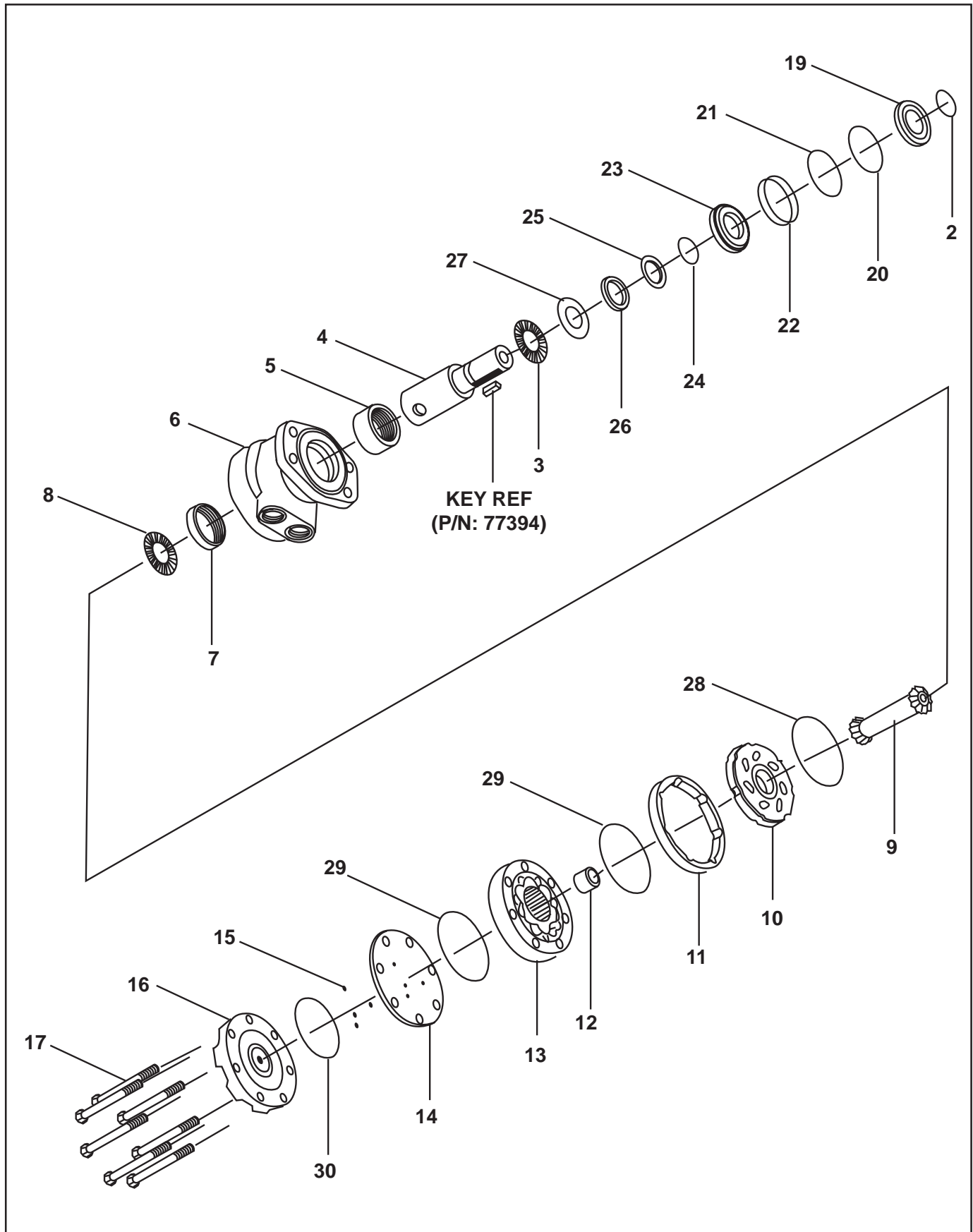

REVISION:



## STANDARD HOPPER AGITATOR MOTOR ASSEMBLY

**B50**  
**PARTS**  
GROUP 20  
FIGURE 05  
PAGE 02

ITEM NO.	REED'S PART NO.	DESCRIPTION					QTY
		1	2	3	4	5	
-1	85811	Assembly, Standard Hopper Agitator Motor (See Group 20, Figure 04 for NHA)					Ref
2		• Ring Wire					1
3		• Bearing, Front Thrust					1
4		• Kit, Shaft					1
5		• Bearing, Front Housing					1
6		• Kit, Housing					1
7		• Bearing, Rear Housing					1
8		• Bearing, Rear Thrust					1
9		• Kit, Drive Link					1
10		• Bearing, Front Thrust					1
11		• Manifold					1
12		• Boot Manifold					1
13		• Kit, Free Turn Rotor					1
14		• Plate, Balance					1
15		• Ball, Steel					4
16		• Cover, Motor End					1
17		• Bolt, Hex (attaching part)					7
-18	85809SK	• Kit, Seal					1
19		• • Seal, Dust					1
20		• • Ring, Split Wire					1
21		• • Shim, Metal Back Up					1
22		• • Seal, High Pressure					1
23		• • Carrier, Seal					1
24		• • Shim, Metal Back Up					1
25		• • Seal, Polyamid					1
26		• • Seal, Shaft					1
27		• • Washer, Thrust					1
28		• • Seal, Rear Housing					1
29		• • Seal, Body					2
30		• • Seal, End Cover					1

DASH (-) ITEM NOT ILLUSTRATED

REVISION:



# 3 SPOOL CONTROL VALVE ASSEMBLY

B50  
PARTS  
GROUP 20  
FIGURE 06  
PAGE 01

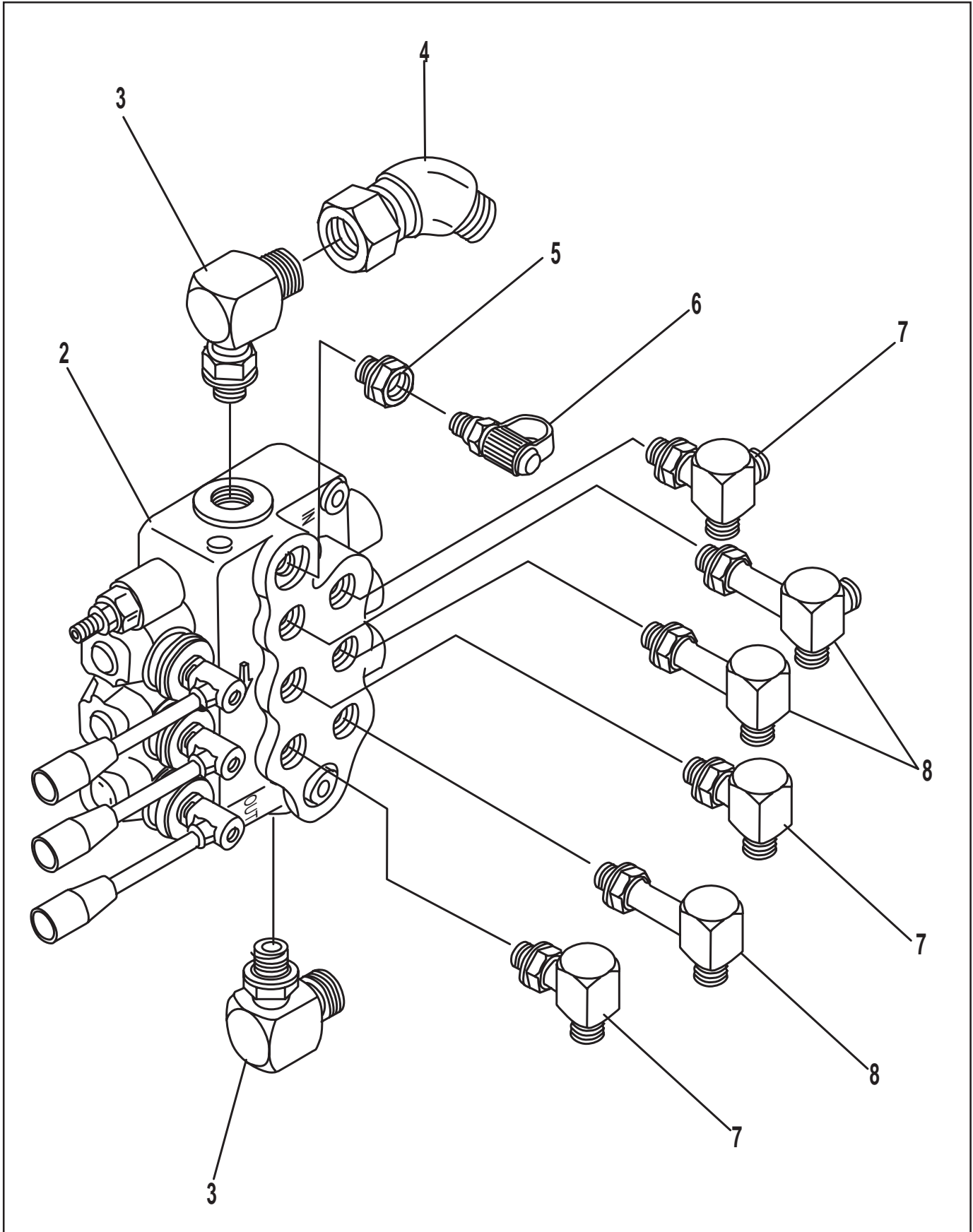

REVISION:



### 3 SPOOL CONTROL VALVE ASSEMBLY

**B50**  
**PARTS**  
GROUP 20  
FIGURE 06  
PAGE 02

ITEM NO.	REED'S PART NO.	DESCRIPTION					QTY
		1	2	3	4	5	
-1	20-08	Assembly, 3 Spool Control Valve (See Group 20, Figure 01 and Figure 02 for NHA)					Ref
2	74471	• Sub-Assembly, Agitator Control Valve (See Group 20, Figure 10 for DET)					1
3		• Fitting, 90					2
4		• Swivel, 45					1
5		• Reducer, 8-6					1
6	800083	• Fitting, Mini Check (Port)					1
7		• Fitting, 90					3
8		• Fitting, 90					3
-9		• Bolt, Hex					2
-10		• Washer, SPL Lock					2

DASH (-) ITEM NOT ILLUSTRATED

REVISION:

## 3 SPOOL CONTROL VALVE SUBASSEMBLY

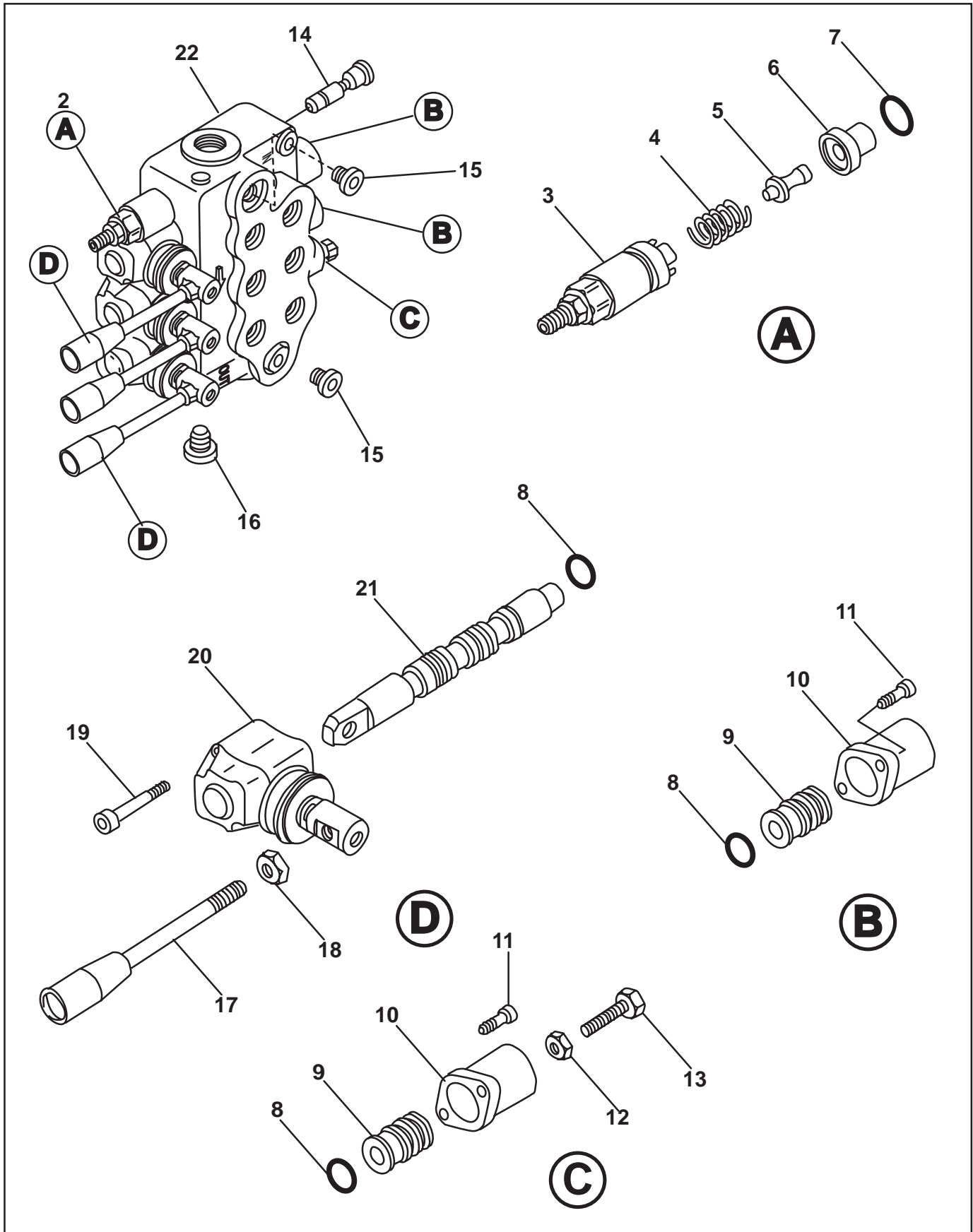

REVISION:



### 3 SPOOL CONTROL VALVE SUBASSEMBLY

**B50**  
**PARTS**  
GROUP 20  
FIGURE 07  
PAGE 02

ITEM NO.	REED'S PART NO.	DESCRIPTION					QTY
		1	2	3	4	5	
-1	74471	Sub-Assembly, 3 Spool Control Valve (See Group 20, Figure 08 for NHA)					Ref
2	85706	Cartridge, Relief					1
3		• • Kit, Screw					1
4		• • Spring					1
5		• • Pin, Screw Kit					1
6		• • Ring					1
7		• • O-Ring					1
8		• O-Ring					4
9		• Kit, Spool Control					3
10		• Cap, Spool					3
11		• Screw, Soc (attaching parts)					6
12		• Nut					1
13		• Bolt, Hex					1
14		• Kit, VRS					1
15		• Plug					2
16		• Plug					1
17		• Handle, Remixer Valve					3
18		• Nut (attaching parts)					3
19		• Screw, SOC					6
20		• Lever, L					3
21		• Spool					3
22		• Body, Valve					1

DASH (-) ITEM NOT ILLUSTRATED

REVISION:



**TRAILER MOUNTED PUMP MODEL *B50*  
ILLUSTRATED PARTS MANUAL**

***B50*  
PARTS  
GROUP 20  
FIGURE 08  
PAGE 01**

THIS PAGE INTENTIONALLY LEFT BLANK





## TRAILER MOUNTED PUMP MODEL *B50* GROUP 30 TANK INSTALLATION

*B50*  
PARTS  
GROUP 30  
FIGURE 01  
PAGE 00

**REED** TRAILER MOUNTED CONCRETE PUMP MODEL *B50* ILLUSTRATED PARTS MANUAL GROUP 30 HYDRAULIC TANK INSTALLATION CONTAINS THE FOLLOWING FIGURES:

- FIGURE 00** TABLE OF CONTENTS
- FIGURE 01** TANK INSTALLATION
- FIGURE 02** HYDRAULIC TANK ASSEMBLY
- FIGURE 03** SWING TUBE CIRCUIT MANIFOLD ASSEMBLY
- FIGURE 04** SWING TUBE CIRCUIT MAIN SOLENOID VALVE ASSEMBLY
- FIGURE 05** SWING TUBE CIRCUIT PILOT SOLENOID VALVE ASSEMBLY
- FIGURE 06** BALL VALVE ASSEMBLY
- FIGURE 07** DRIVE CYLINDER CIRCUIT MANIFOLD ASSEMBLY
- FIGURE 08** DRIVE CYLINDER CIRCUIT MAIN SOLENOID VALVE ASSEMBLY
- FIGURE 09** DRIVE CYLINDER CIRCUIT PILOT SOLENOID VALVE ASSEMBLY
- FIGURE 10** ACCUMULATOR ASSEMBLY
- FIGURE 11** ACCUMULATOR BLADDER REPAIR KIT

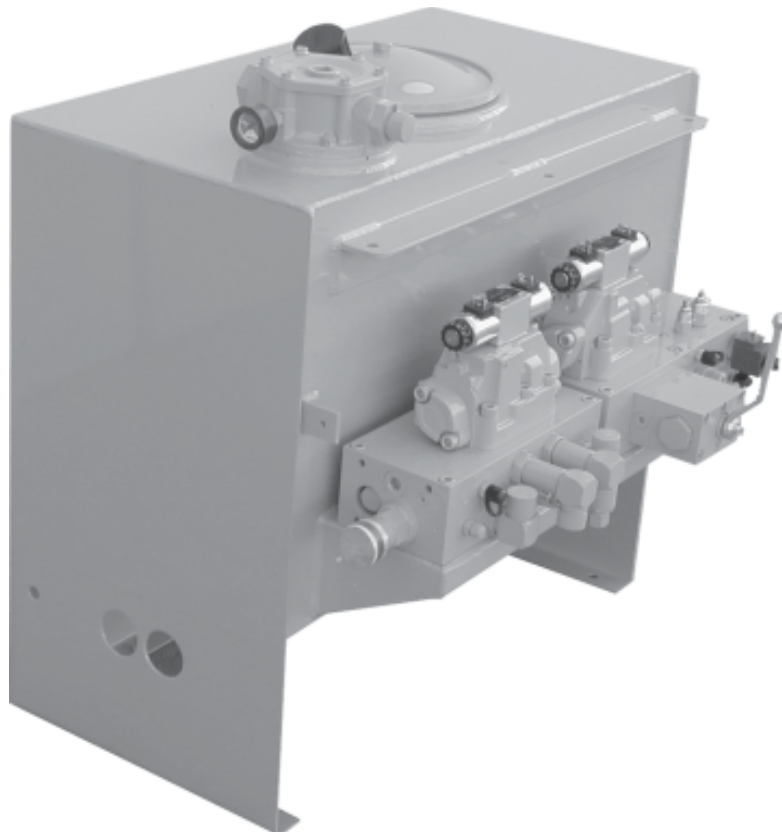

REVISION:

## TRAILER MOUNTED PUMP MODEL B50 GROUP 30 TANK INSTALLATION

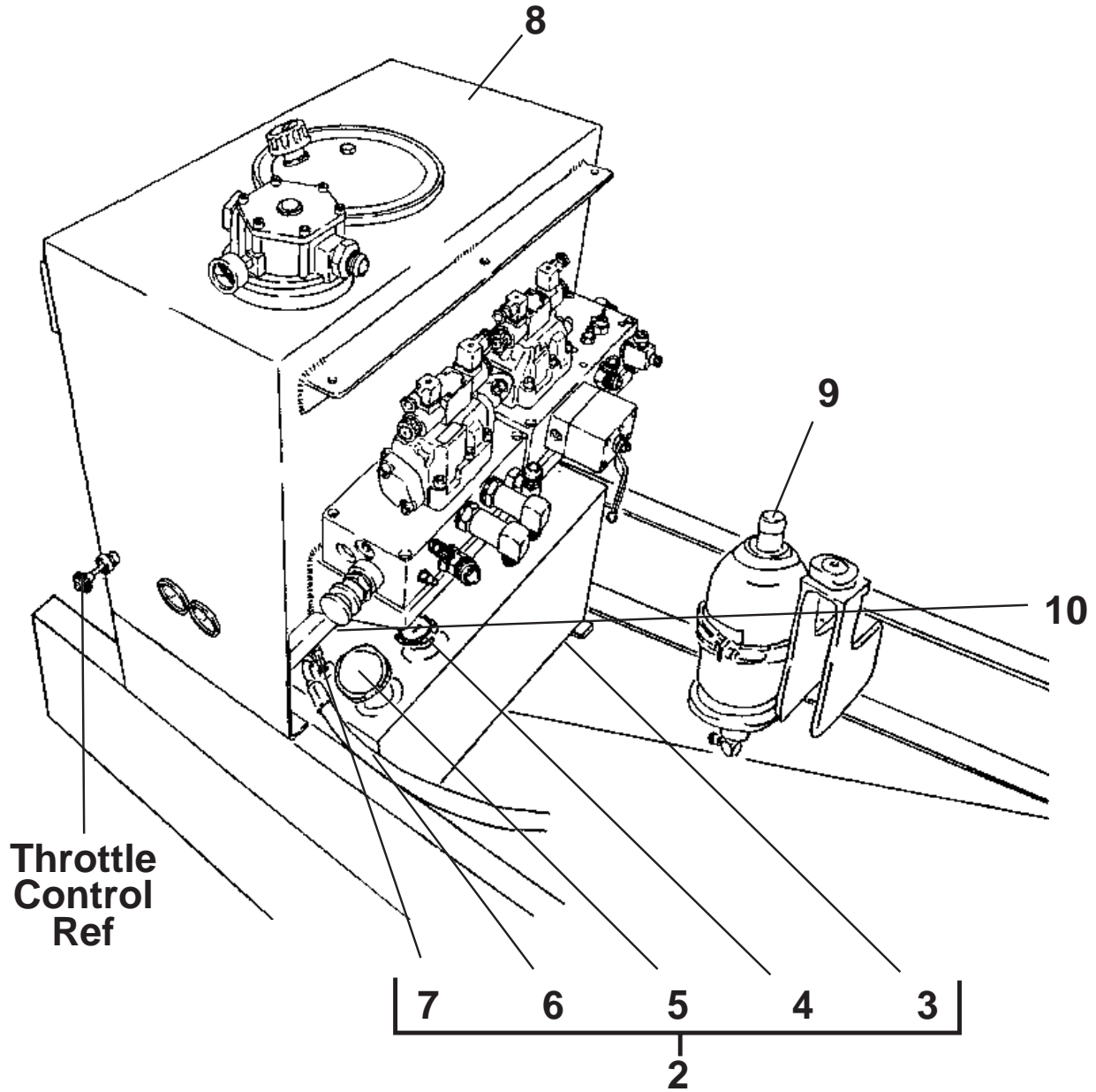



# TANK INSTALLATION

**B50**  
**PARTS**  
GROUP 30  
FIGURE 01  
PAGE 02

ITEM NO.	REED'S PART NO.	DESCRIPTION					QTY
		1	2	3	4	5	
-1	30-01	Installation, Tank (See Group 10, Figure 01, 02, 03, and 04 for NHA)					Ref
2	85363	• Assembly, Fuel Tank					1
3	85111	• • Weldment, Fuel Tank					1
4	85569	• • Gauge, Fuel					1
5	85570	• • Cap, Fuel					1
6	85862	• • Assembly, Fuel Pick Up Tube					2
7		• • Elbow, 90					2
8	85361	• Assembly, Hydraulic Tank (See Group 30, Figure 02 for DET)					1
9	30-10	• Assembly, Accumulator (See Group 30, Figure 10 for DET)					1
10	85815	• Valve, Solenoid					1
-11	85701	• • Cartridge, Solenoid Valve					1
-12	85702	• • Coil, 12 VDC					1
-13	74716	• Hose, 6 Feet Fuel					1
-14	10577	• Clamp, Fuel Hose					2
-15	86365	• Kit, Hose (See SCHEMATIC Section, Page 05 for DET)					1

DASH (-) ITEM NOT ILLUSTRATED

REVISION:

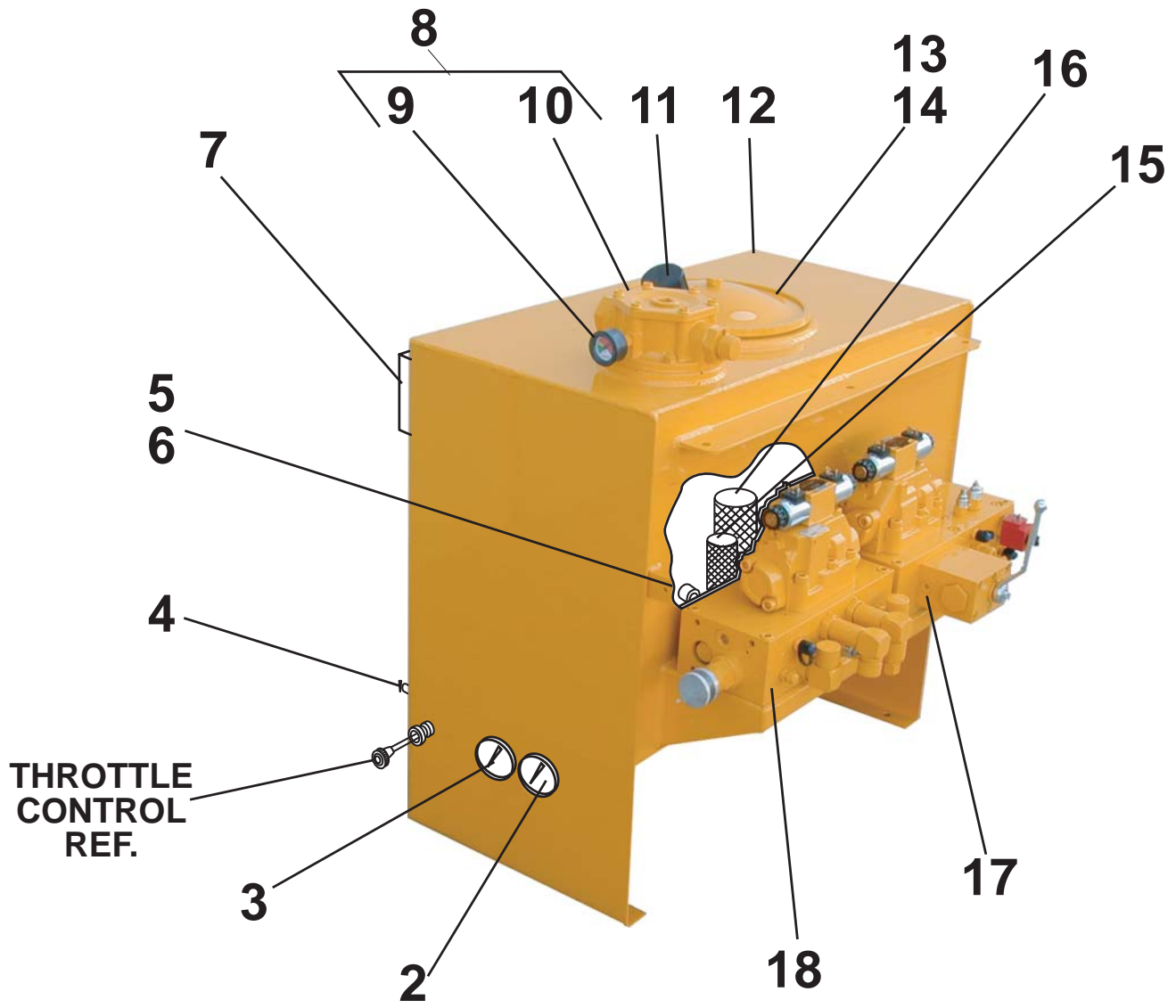



# HYDRAULIC TANK ASSEMBLY

**B50**  
**PARTS**  
GROUP 30  
FIGURE 02  
PAGE 02

ITEM NO.	REED'S PART NO.	DESCRIPTION					QTY
		1	2	3	4	5	
-1	85361	Assembly, Hydraulic Tank (See Group 30, Figure 01 for NHA)					Ref
2	70366	• Gauge, 3,000 PSI Hydraulic					1
3	74562	• Gauge, 6,000 PSI Hydraulic					1
4	801025	• Cock, Drain					1
5	85574	• Valve, 2 Inch Check					1
6	10981	• Nipple, 2 Inch					1
7	74509	• Gauge, Sight					1
8	85282	• Filter, Return					1
9	85575	• • Gauge, Return Filter					1
10	85283	• • Element, Return Filter					1
11	85537	• • Filter, Breather					1
12	85102	• • Weldment, Hydraulic Tank					1
13	85824	• • End Cover, Hydraulic Tank					1
14	85867	• • Gasket, End Cover					1
15	79247	• Separator, Magnetic					1
16	800230	• Separator, Magnetic					1
17	85249	• Assembly, Swing Tube Circuit Manifold (See Group 30, Figure 03 for DET)					1
18	85248	• Assembly, Drive Cylinder Circuit Manifold (See Group 30, Figure 07 for DET)					1
-19	78598	• Plug, Hoffman					A/R

DASH (-) ITEM NOT ILLUSTRATED

REVISION:

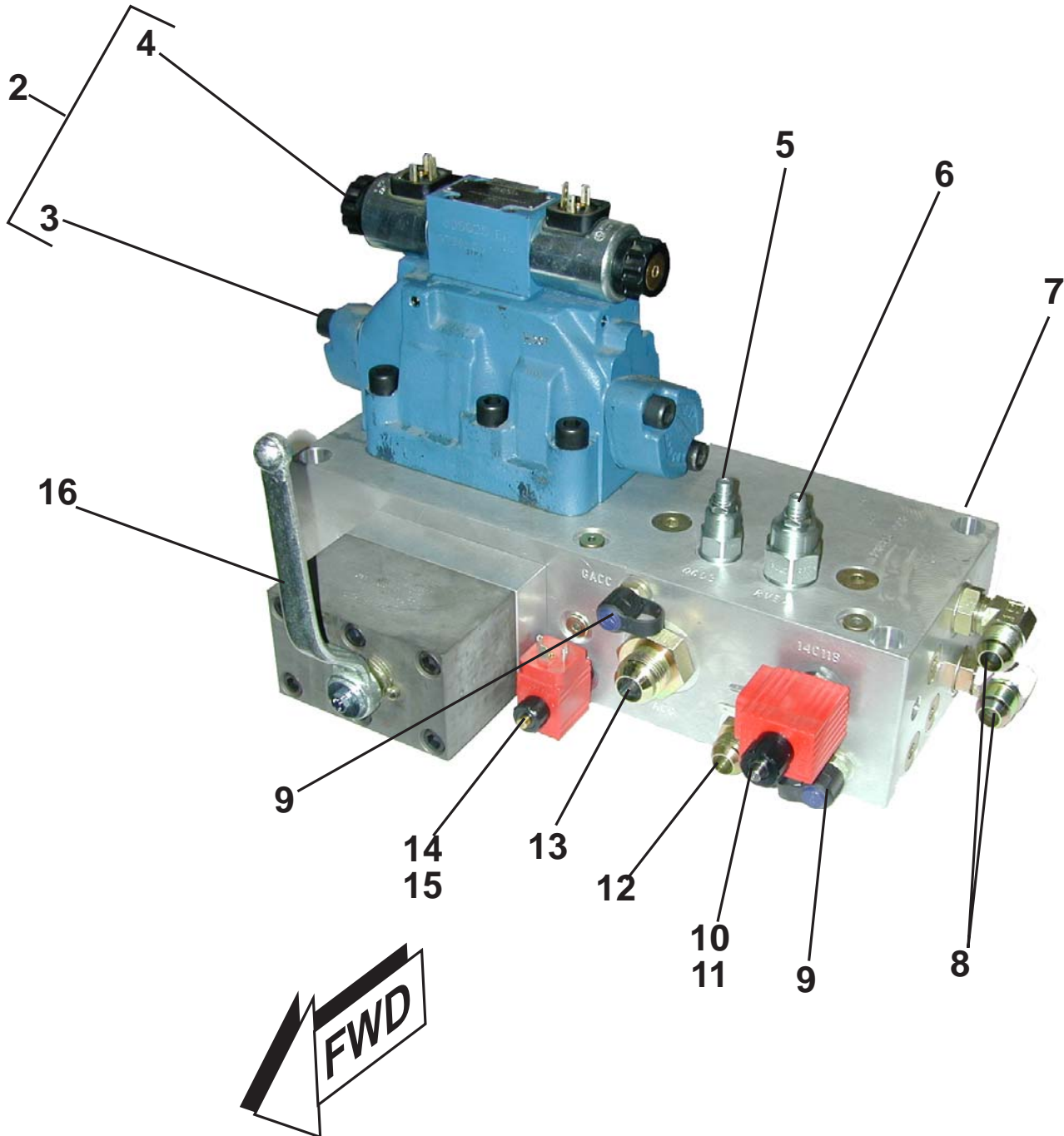



# SWING TUBE CIRCUIT MANIFOLD ASSEMBLY

**B50**  
**PARTS**  
GROUP 30  
FIGURE 03  
PAGE 02

ITEM NO.	REED'S PART NO.	DESCRIPTION					QTY
		1	2	3	4	5	
-1	85249	Assembly, Swing Tube Circuit Manifold (See Group 30, Figure 02 for NHA)					Ref
2	85693	• Assembly, Swing Tube Circuit Solenoid Valve					1
3	85694	• • Assembly, Swing Tube Circuit Main Solenoid Valve (See Group 30, Figure 04 for DET)					1
4	85695	• • Assembly, Swing Tube Circuit Pilot Solenoid Valve (See Group 30, Figure 05 for DET)					1
5	85704	• Cartridge, Unloader Valve					1
-5A	85704SK	• • Kit, Unloader Valve Cartridge Seal					1
6	85703	• Cartridge, Relief Valve					1
-6A	85703SK	• • Kit, Relief Valve Cartridge Seal					1
7		• Body, Swing Tube Circuit Manifold					1
8		• Elbow, 90					2
9	78593	• Port, Mini Check					2
10	85701	• Cartridge, SV4 Solenoid Valve					1
11	85702	• • Coil, SV4 Solenoid Valve Cartridge					1
12		• Fitting, STR					1
13		• Fitting, STR					1
14	857699	• Cartridge, SV3 Solenoid Valve					1
15	85700	• • Coil, SV3 Solenoid Valve Cartridge					1
16	85705	• Assembly, Ball Valve (See Group 30, Figure 06 for DET)					1

DASH (-) ITEM NOT ILLUSTRATED

REVISION:



# SWING TUBE CIRCUIT MAIN SOLENOID VALVE ASSEMBLY

B50  
PARTS  
GROUP 30  
FIGURE 04  
PAGE 01

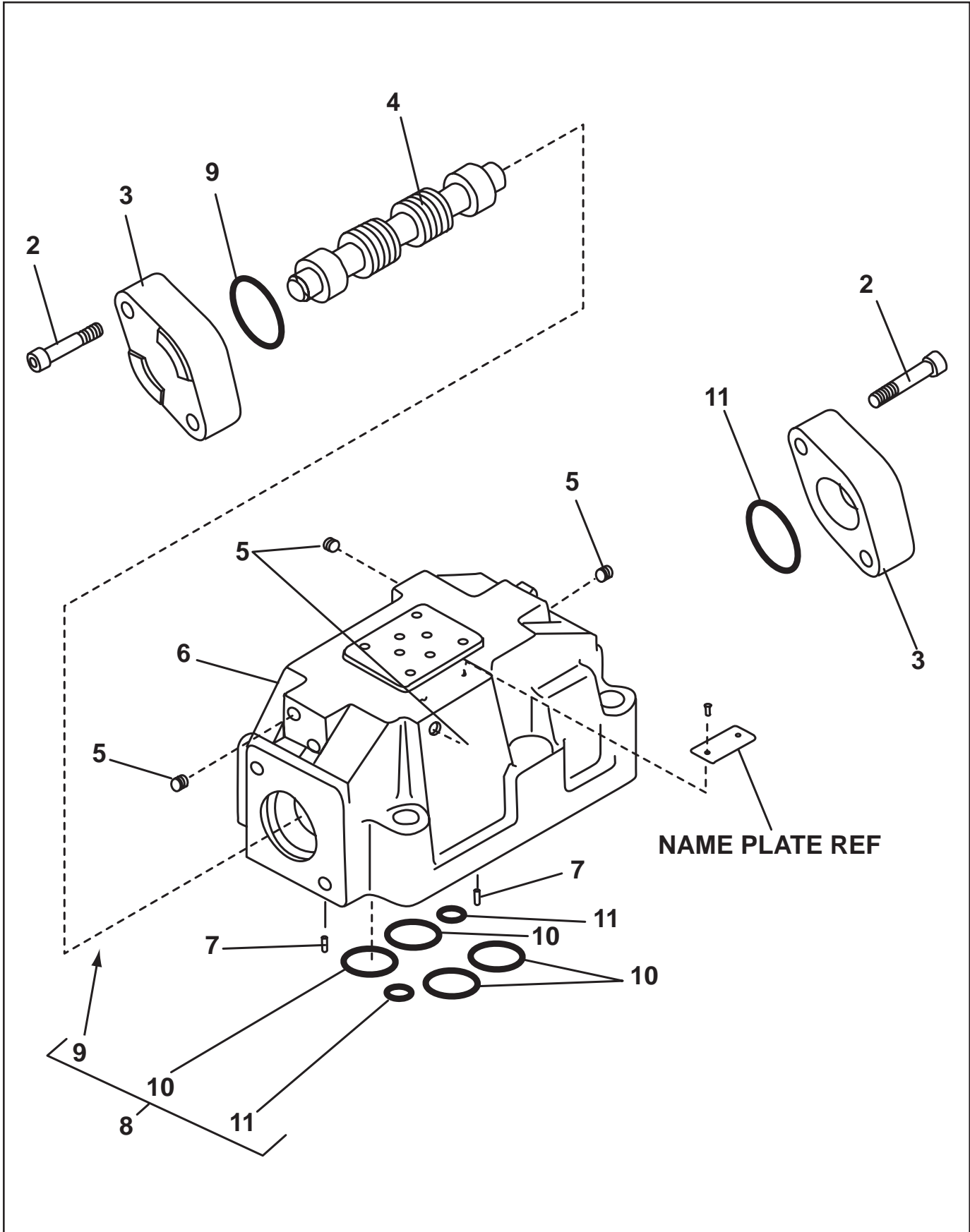

REVISION:





# SWING TUBE CIRCUIT MAIN SOLENOID VALVE ASSEMBLY

**B50**  
**PARTS**  
GROUP 30  
FIGURE 04  
PAGE 02

ITEM NO.	REED'S PART NO.	DESCRIPTION					QTY
		1	2	3	4	5	
-1	85694	Assembly, Swing Tube Circuit Main Solenoid Valve (See Group 30, Figure 03 for NHA)					Ref
2					• Screw, SOC	4	
3					• Cover	2	
4					• Spool	1	
5					• Plug	4	
6					• Housing, Cartridge	1	
7					• Pin, Grooved	2	
8	74994				• Kit, Seal	1	
9					• • O-Ring	2	
10					• • O-Ring	4	
11					• • O-Ring	2	

DASH (-) ITEM NOT ILLUSTRATED

REVISION:



# SWING TUBE CIRCUIT PILOT SOLENOID VALVE ASSEMBLY

B50  
PARTS  
GROUP 30  
FIGURE 05  
PAGE 01

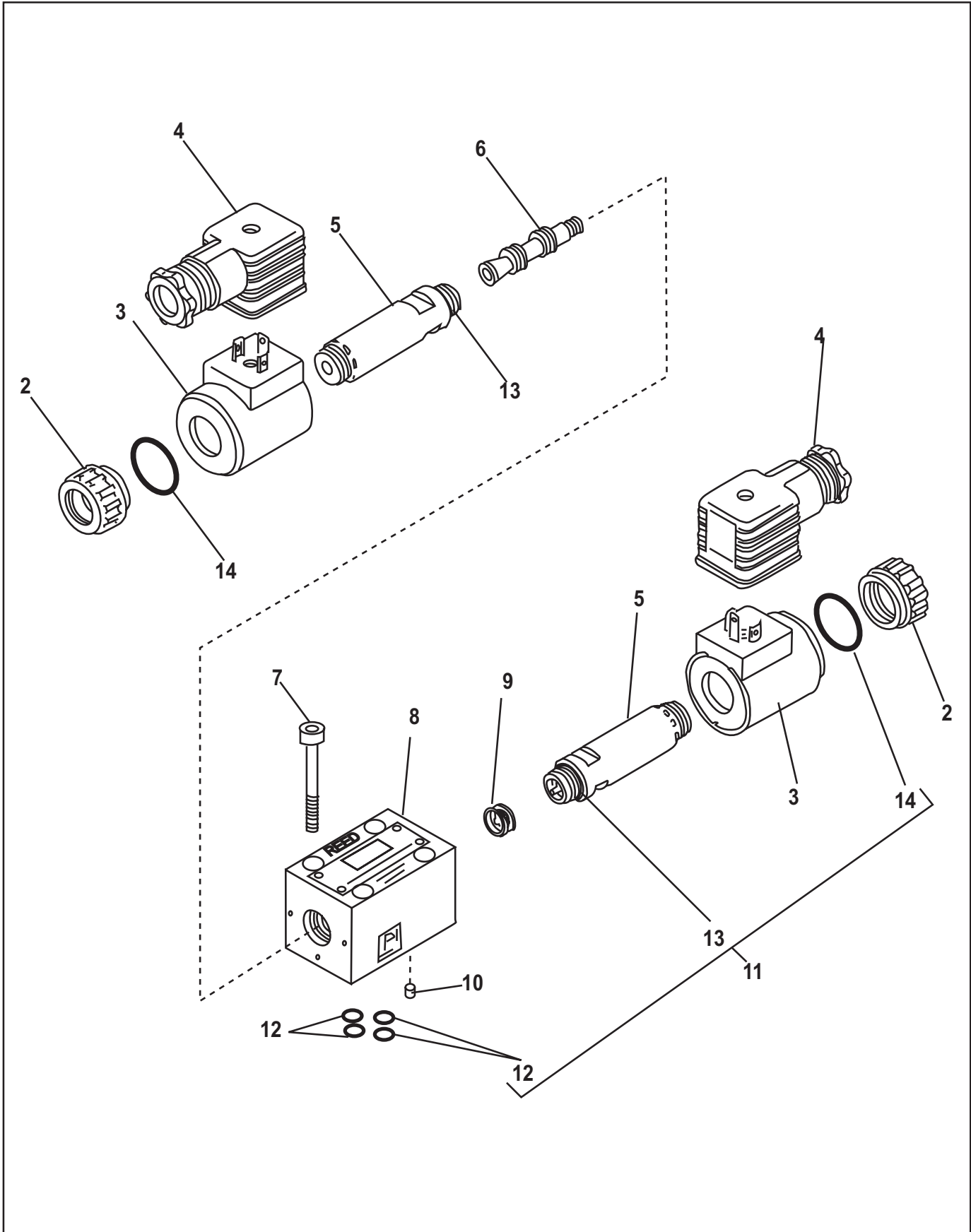

REVISION:



# SWING TUBE CIRCUIT PILOT SOLENOID VALVE ASSEMBLY

**B50**  
**PARTS**  
GROUP 30  
FIGURE 05  
PAGE 02

ITEM NO.	REED'S PART NO.	DESCRIPTION					QTY
		1	2	3	4	5	
-1	15-Aug	Assembly, Swing Tube Circuit Pilot Solenoid Valve (See Group 30, Figure 03 for NHA)					Ref
2		• Cap, Coil					2
3	85692	• Coil Solenoid					2
4	74597	• Connector, Plug					2
5		• Armature					2
6		• Spool					1
7		• Screw SOC					4
8		• Housing, Solenoid Valve					1
9		• Detent					1
10		• Orifice					1
11	72313	• Kit, O-Ring					1
12		• • O-Ring					4
13		• • O-Ring					2
14		• • O-Ring					2

DASH (-) ITEM NOT ILLUSTRATED

REVISION:



# BALL VALVE ASSEMBLY

*B50*  
PARTS  
GROUP 30  
FIGURE 06  
PAGE 01

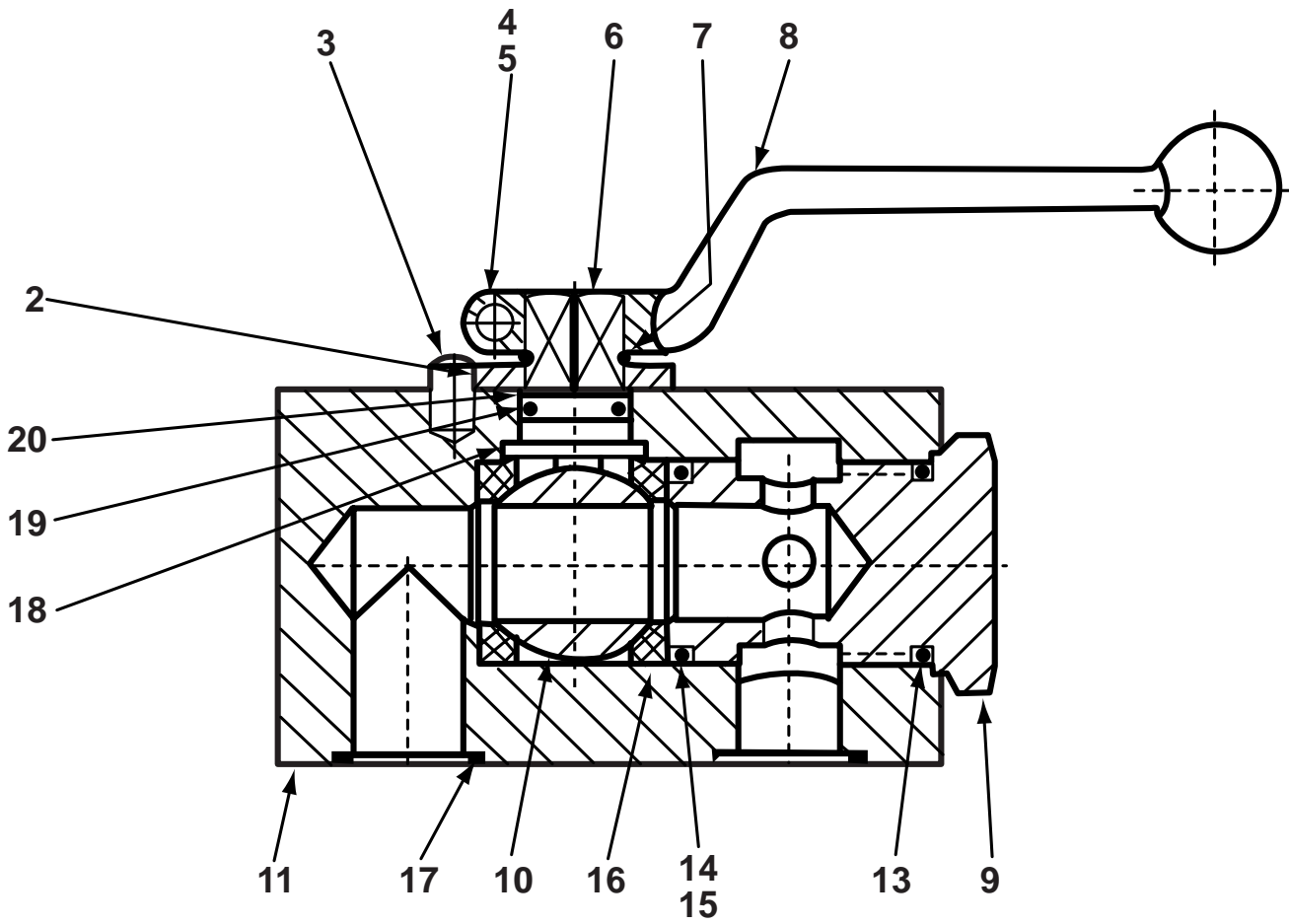

REVISION:



# BALL VALVE ASSEMBLY

**B50**  
**PARTS**  
GROUP 30  
FIGURE 06  
PAGE 02

ITEM NO.	REED'S PART NO.	DESCRIPTION	QTY
		1 2 3 4 5	
-1	85705	Assembly, Ball Valve (See Group 30, Figure 03 for NHA)	Ref
2		• Washer, Limit	1
3		• Pin, Stop	1
4		• Bolt, Hex	1
5		• Nut, Hex	1
6		• Handle, Control	1
7		• Spindle, Control	1
8		• Retainer, Spring	1
9		• Plug	1
10		• Ball	1
11		• Housing	1
-12		• Kit, Seal	1
13		• • O-Ring	1
14		• • O-Ring	1
15		• • Ring, Back Up	1
16		• • Seal, Bowl	2
17		• • O-Ring	1
18		• • Washer, Thrust	1
19		• • O-Ring	1
20		• • Ring, Back Up	1

DASH (-) ITEM NOT ILLUSTRATED

REVISION:



# DRIVE CYLINDER CIRCUIT MANIFOLD ASSEMBLY

**B50**  
**PARTS**  
GROUP 30  
FIGURE 07  
PAGE 01

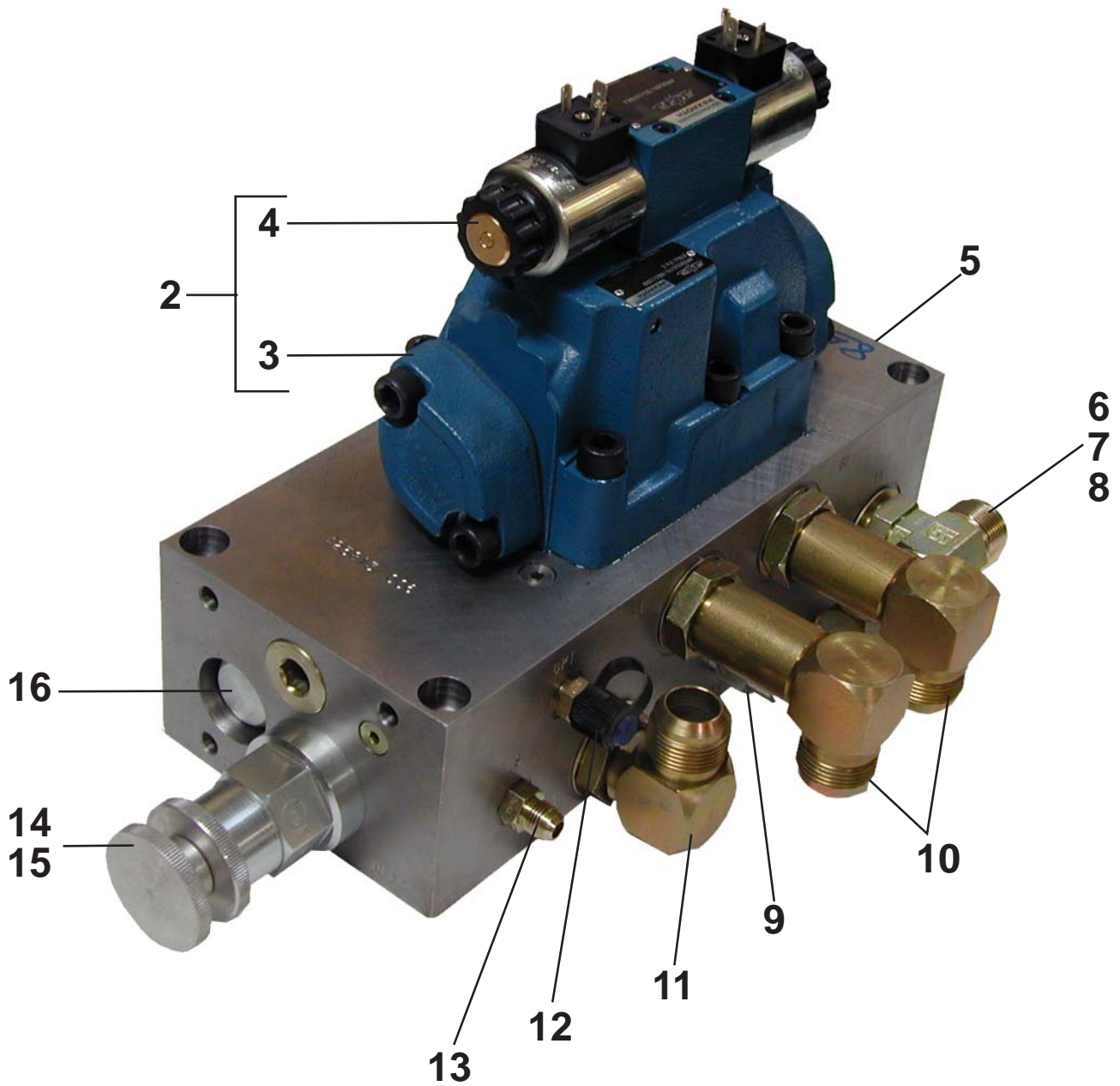

REVISION:



# DRIVE CYLINDER CIRCUIT MANIFOLD ASSEMBLY

**B50**  
**PARTS**  
GROUP 30  
FIGURE 07  
PAGE 02

ITEM NO.	REED'S PART NO.	DESCRIPTION					QTY
		1	2	3	4	5	
-1	85248	Assembly, Drive Cylinder Circuit Manifold (See Group 30, Figure 02 for NHA)					Ref
2	85689	• Assembly, Drive Cylinder Circuit Solenoid Valve					1
3	85690	• • Assembly, Drive Cylinder Circuit Main Solenoid Valve (See Group 30, Figure 08 for DET)					1
4	85691	• • Assembly, Drive Cylinder Circuit Pilot Solenoid Valve (See Group 30, Figure 09 for DET)					1
5		• Body, Drive Cylinder Circuit Manifold					1
6		• Tee					1
7		• Reducer					1
8		• Plug					1
9	85696	• Cartridge, Relief Valve					1
10		• Elbow, 90					2
11		• Elbow, 45					1
12	78593	• Port, Mini Check					1
13		• Fitting, STR					1
14	85697	• Cartridge, Flow Control Valve					1
15	85697SK	• Kit, Flow Control Valve Cartridge Seal					1
16	85698	• Cartridge, Check Valve					1

DASH (-) ITEM NOT ILLUSTRATED

REVISION:



# DRIVE CYLINDER CIRCUIT MAIN SOLENOID VALVE ASSEMBLY

B50  
PARTS  
GROUP 30  
FIGURE 08  
PAGE 01

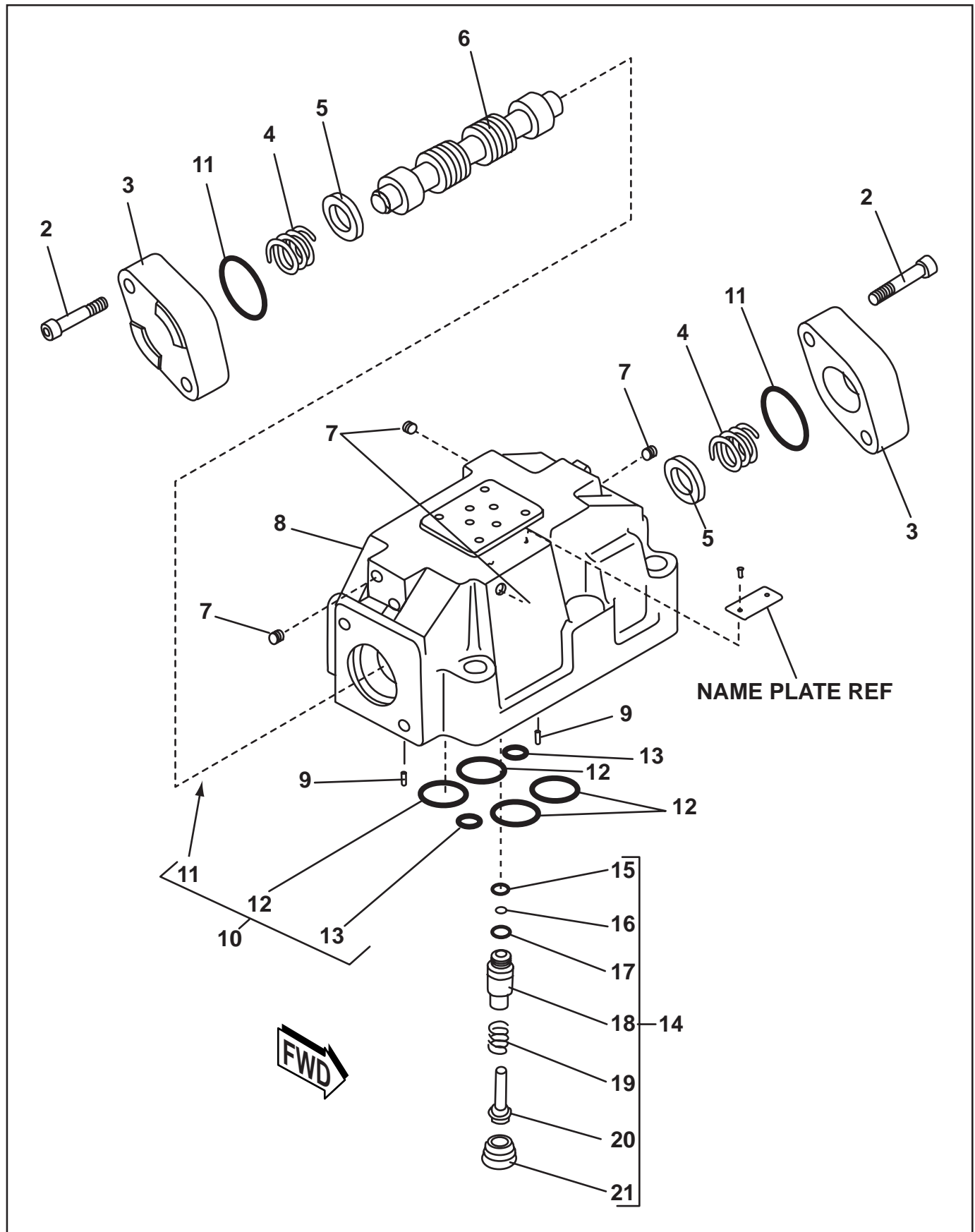

REVISION:





## DRIVE CYLINDER CIRCUIT MAIN SOLENOID VALVE ASSEMBLY

**B50**  
**PARTS**  
GROUP 30  
FIGURE 08  
PAGE 02

ITEM NO.	REED'S PART NO.	DESCRIPTION					QTY
		1	2	3	4	5	
-1	85690	Assembly, Drive Cylinder Circuit Main Solenoid Valve (See Group 30, Figure 07 for NHA)					Ref
2		• Screw, SOC					4
3		• Cover					2
4		• Spring, Compression					2
5		• Plate, Spring					2
6		• Spool					1
7		• Plug					4
8		• Housing, Cartridge					1
9		• • Pin, Grooved					2
10	74994	• • Kit, Seal					1
11		• • O-Ring					2
12		• • O-Ring					4
13		• • O-Ring					2
14	73147	• Sub-Assembly, Pilot Pressure Valve					1
15		• • O-Ring					1
16		• • Circlip					1
17		• • O-Ring					1
18		• • Sleeve					1
19		• • Spring, Compression					1
20		• • Cone					1
21		• • Valve Seat					1

DASH (-) ITEM NOT ILLUSTRATED

REVISION:



# DRIVE CYLINDER CIRCUIT PILOT SOLENOID VALVE ASSEMBLY

B50  
PARTS  
GROUP 30  
FIGURE 09  
PAGE 01

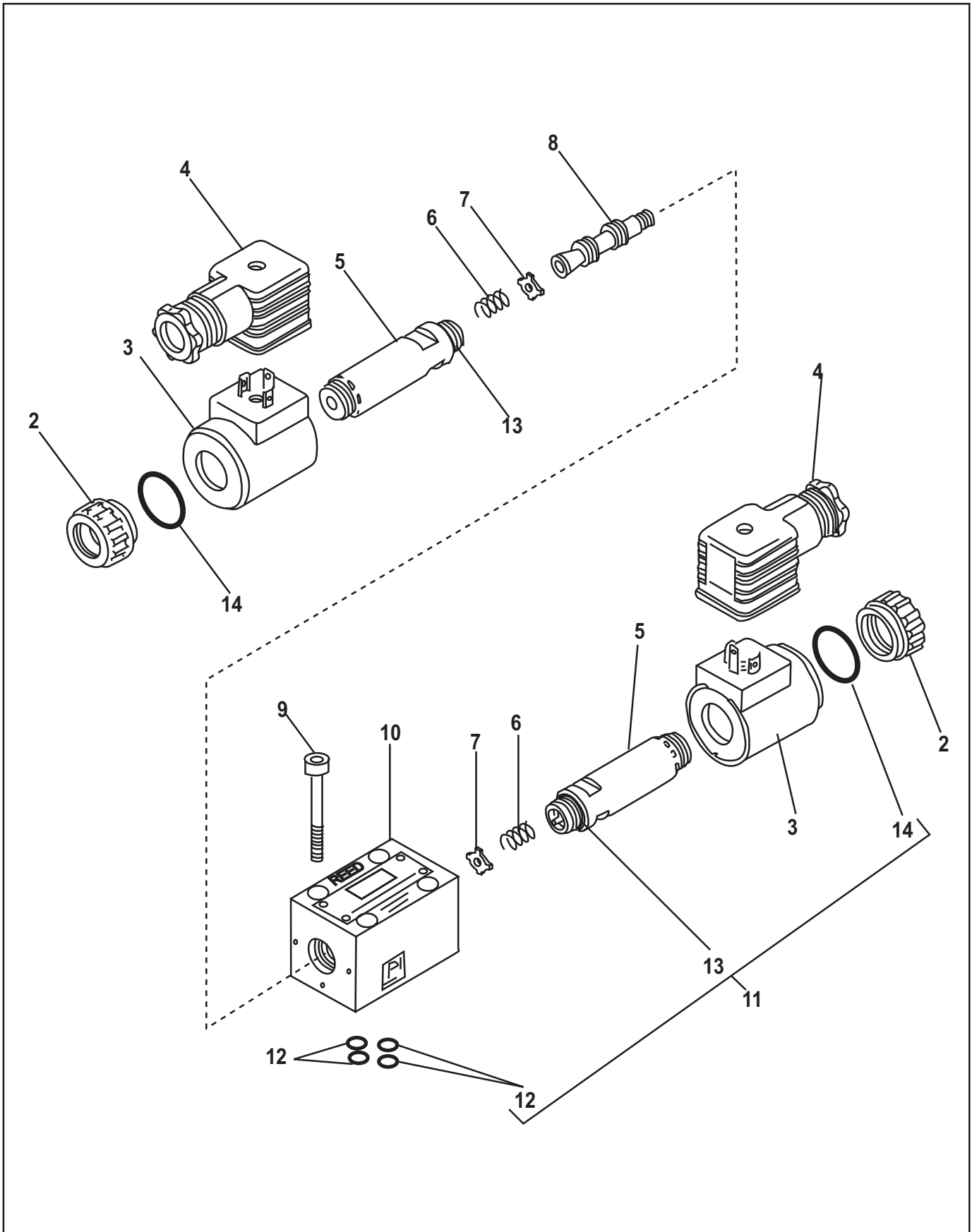

REVISION:



# DRIVE CYLINDER CIRCUIT PILOT SOLENOID VALVE ASSEMBLY

**B50**  
**PARTS**  
GROUP 30  
FIGURE 09  
PAGE 02

ITEM NO.	REED'S PART NO.	DESCRIPTION					QTY
		1	2	3	4	5	
-1	85695	Assembly, Swing Tube Circuit Pilot Solenoid Valve (See Group 30, Figure 03 for NHA)					Ref
2					• Cap, Coil	2	
3	85692				• Coil, Solenoid	2	
4	74597				• Connector, Plug	2	
5					• Armature	2	
6					• Spool	1	
7					• Screw, SOC	4	
8					• Housing, Solenoid Valve	1	
9					• Detent	1	
10					• Orifice	1	
11	72313				• Kit, O-Ring	1	
12					• • O-Ring	4	
13					• • O-Ring	2	
14					• • O-Ring	2	

DASH (-) ITEM NOT ILLUSTRATED

REVISION:

## ACCUMULATOR ASSEMBLY

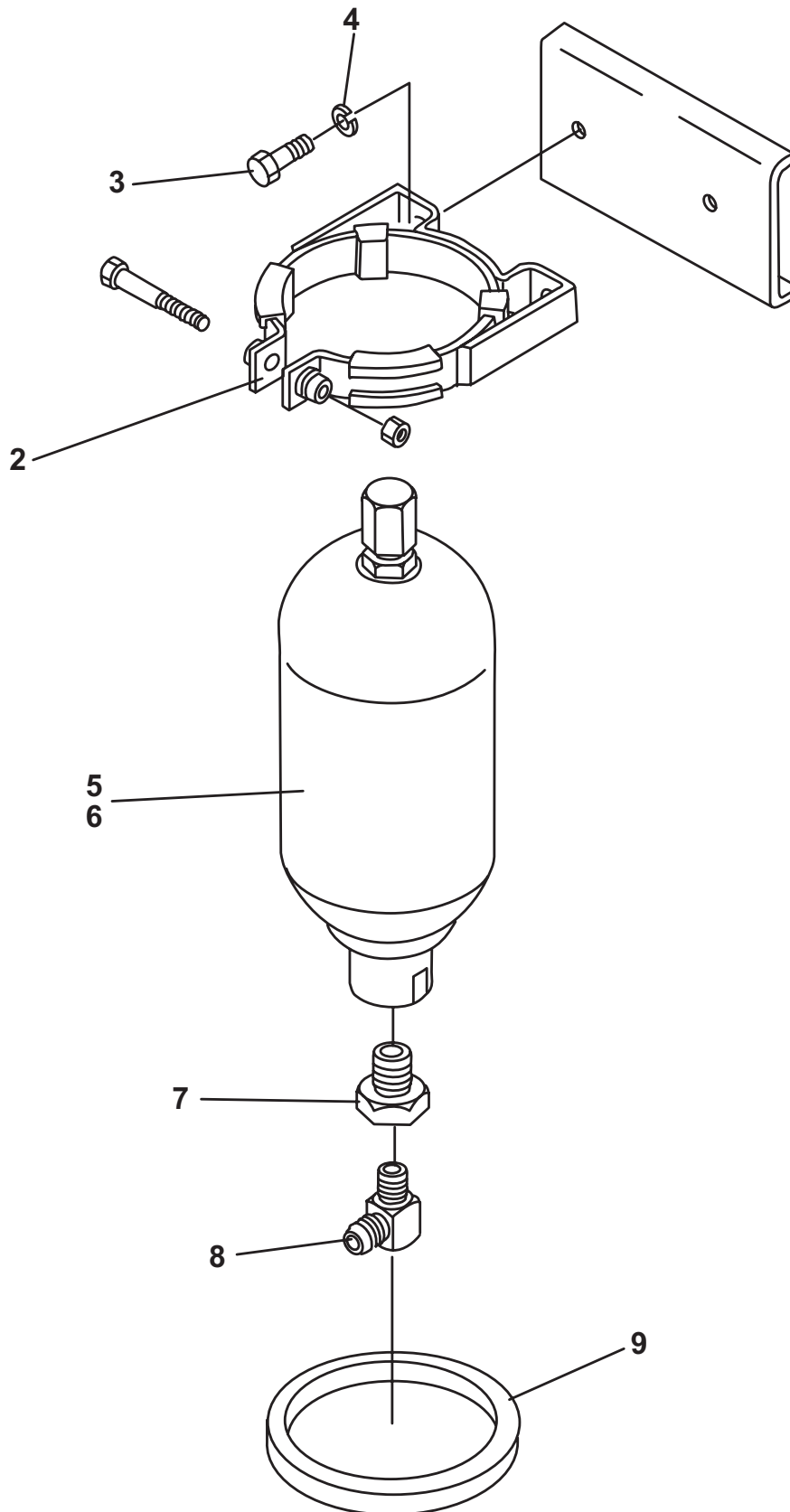



# ACCUMULATOR ASSEMBLY

**B50**  
**PARTS**  
GROUP 30  
FIGURE 10  
PAGE 02

ITEM NO.	REED'S PART NO.	DESCRIPTION	QTY
		1 2 3 4 5	
-1	30-10	Assembly, Accumulator (See Group 30, Figure 01 for NHA)	Ref
2	73171	• Bracket, Accumulator	1
3		• Bolt, Hex (attaching parts)	2
4		• Washer, Lock (attaching parts)	2
5	74515	• Accumulator, 1 Gal	1
6	30-11	• Kit, Bladder Repair (See Group 30, Figure 11 for REF)	1
7		• Reducer	1
8		• Elbow, 90	1
9	801028	• Grommet, Accumulator	1
-10	71460	• Kit, Accumulator Charge (See Group 80, Figure 07 for REF)	Ref

DASH (-) ITEM NOT ILLUSTRATED

REVISION:



# ACCUMULATOR BLADDER REPAIR KIT

**B50**  
**PARTS**  
GROUP 30  
FIGURE 11  
PAGE 01

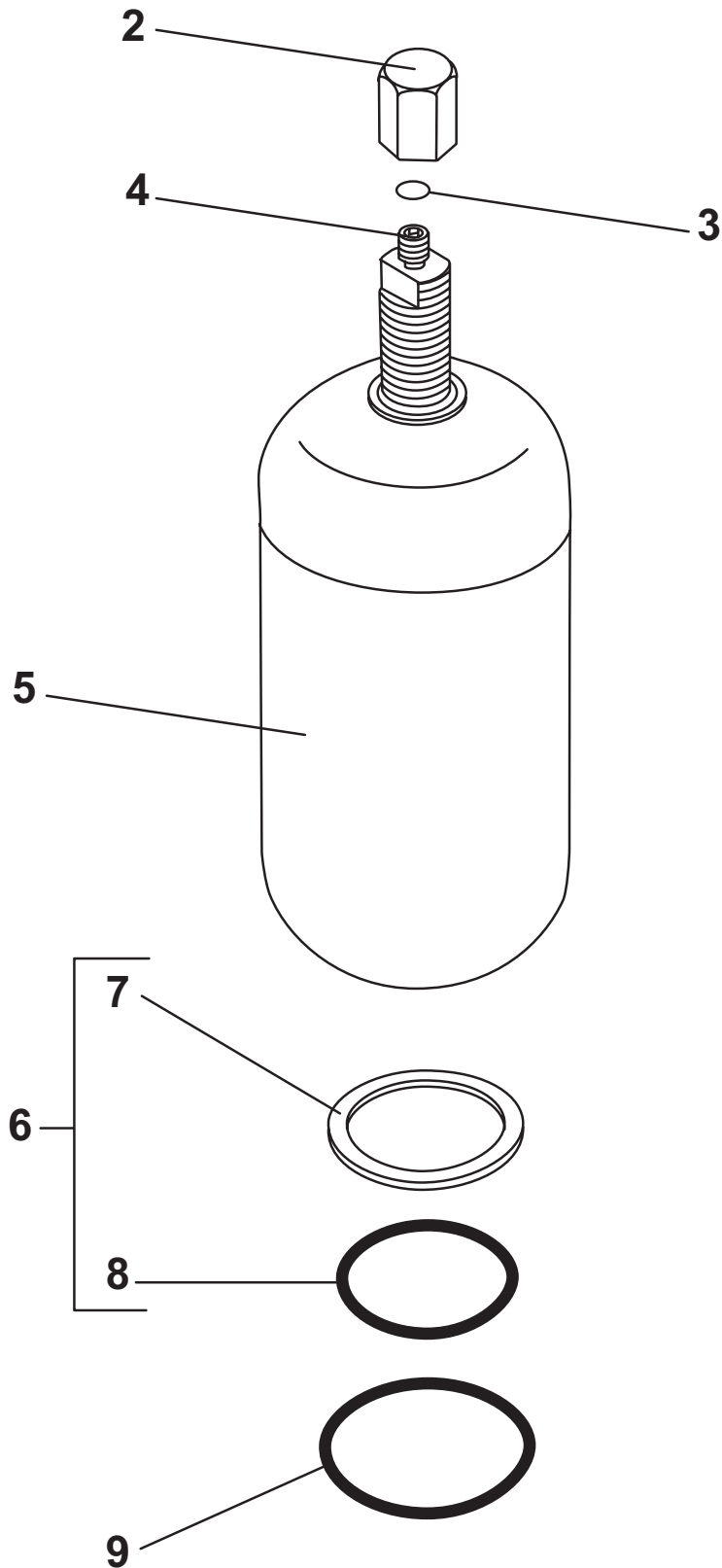

REVISION:



# ACCUMULATOR BLADDER REPAIR KIT

**B50**  
**PARTS**  
GROUP 30  
FIGURE 11  
PAGE 02

ITEM NO.	REED'S PART NO.	DESCRIPTION					QTY
		1	2	3	4	5	
-1	30-11	Kit, Bladder Repair (Also See Group 30, Figure 10 for NHA)					Ref
2		• Cap, Valve Seal					1
3		• O-Ring					1
4		• Core, Gas Valve					1
5	74516	• Bladder, 1 Gal					1
6	85812	• Kit, Bladder Seal					1
7		• • Ring, Flat					1
8		• • O-Ring					1
9		• Ring, Back Up					1

DASH (-) ITEM NOT ILLUSTRATED



**TRAILER MOUNTED PUMP MODEL *B50*  
ILLUSTRATED PARTS MANUAL**

*B50*  
**PARTS  
GROUP 30  
FIGURE 12  
PAGE 01**

THIS PAGE INTENTIONALLY LEFT BLANK



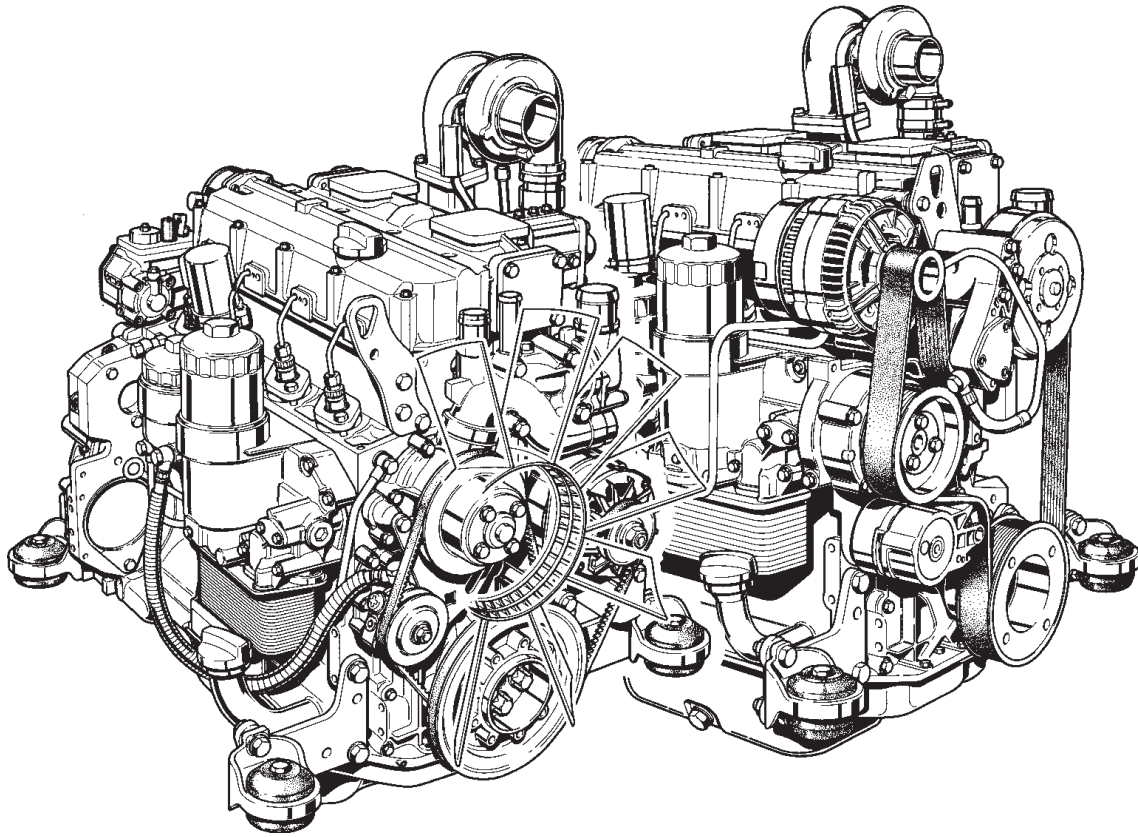

**REED** TRAILER MOUNTED CONCRETE PUMP MODEL **B50** ILLUSTRATED PARTS MANUAL GROUP 40 POWER TRAIN INSTALLATION CONTAINS THE FOLLOWING FIGURES:

- FIGURE 00** TABLE OF CONTENTS
- FIGURE 01** POWER TRAIN INSTALLATION
- FIGURE 02** HYDRAULIC PUMPS ASSEMBLY
- FIGURE 03** SINGLE AUXILIARY PUMP ASSEMBLY
- FIGURE 04** DOUBLE AUXILIARY PUMP ASSEMBLY
- FIGURE 05** MAIN PUMP ASSEMBLY
- FIGURE 06** BATTERY MOUNTING ASSEMBLY

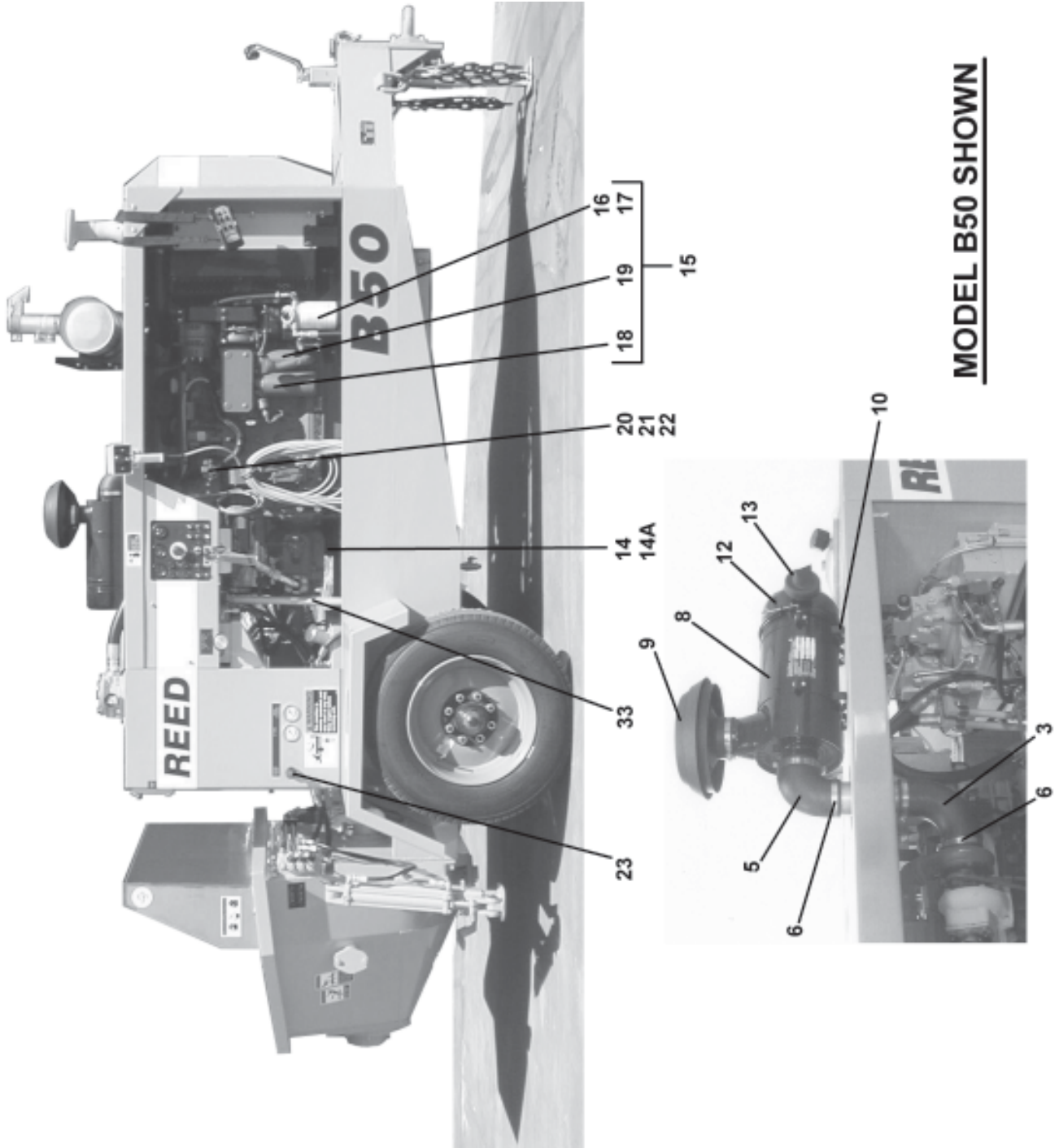



# POWER TRAIN INSTALLATION

**B50**  
**PARTS**  
GROUP 40  
FIGURE 01  
PAGE 02

ITEM NO.	REED'S PART NO.	DESCRIPTION					QTY
		1	2	3	4	5	
-1	40-01	Installation, Power Train (See Group 10, Figure 01, 02, 03 and 04 for NHA)					Ref
2	40-02	• Assembly, Main and Auxiliary Pumps (See Group 40, Figure 02 for DET)					1
3	87187	• Elbow, 3 Inch Rubber					1
-4	87212	• Bracket, Fuel Filter Mount					4
5	87188	• Elbow, Reducer					1
6	74461	• Clamp					4
7	10577	• Clamp, Hose					2
8	87190	• Cleaner, Air					1
8A	87241	• • Element, Air Cleaner					1
9	87189	• Hood, Inlet					1
10	78193	• Band, Mounting					2
11	87242	• Nut, Wing					2
11A	85348	• Switch, 12 VDC Solenoid					1
12	87243	• Cap, Dust					1
13	87244	• Valve, Vaculator					1
14	BW10270	• Mount, Engine					2
14A	BW10267	• Washer, Fender 3/4"					4
15	87143	• Assembly, Engine (See Vendor Section, Figure 01 for REF)					1
16	87245	• • Element, Water Separator Filter					1
17	74716	• • Hose, 7 Feet Fuel					1
18	74500	• • Element, Oil Filter					1
19	87239	• • Element, Fuel Filter					1
20	87192	• Bracket, Start Solenoid					1
21	78202	• Coupler, Throttle Cable					1
22	72294	• Bolt, Throttle Control					1
23	78201	• Cable, Throttle Control					1
33	85426	• Tube, Hydraulic Cylinders					2

REVISION:



# POWER TRAIN INSTALLATION

**B50**  
**PARTS**  
GROUP 40  
FIGURE 01  
PAGE 03

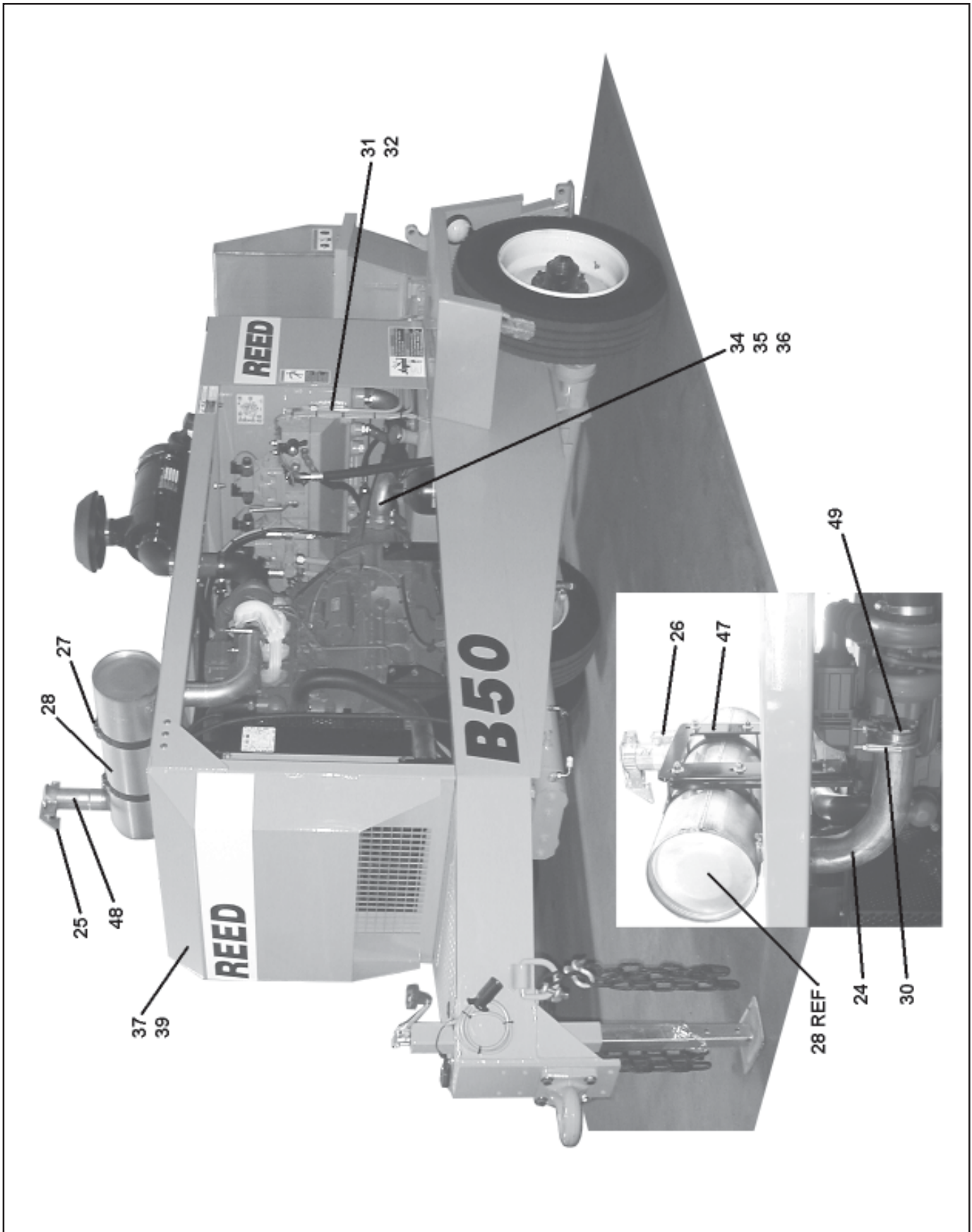

REVISION:



# POWER TRAIN INSTALLATION

**B50**  
**PARTS**  
GROUP 40  
FIGURE 01  
PAGE 04

ITEM NO.	REED'S PART NO.	DESCRIPTION					QTY
		1	2	3	4	5	
24	86648	• Elbow, Exhaust 3"					1
25	73475	• Cap, Rain 3"					1
26	87199	• Clamp 3"					2
27	87199	• Band, Air Cleaner Mounting					2
28	87197	• Muffler, Exhaust					1
-29	73269	• Strap, Ground					1
30	77258	• Clamp					2
31	85429	• Tube, Hydraulic Shift Cylinder					1
32	85428	• Tube, Hydraulic Shift Cylinder					1
33	85426	• Tube, Hydraulic Cylinders					2
34	85661-003	• Hose, Main Pump Suction					1
35	74310	• Clamp, Severe Service					1
36	85732	• Adapter, Suction					1
37	BW10277	• Cooler, Oil					1
38	40-06	• Assembly, Battery Mounting (See Group 40, Figure 06 for DET)					1
39	87164	• Ring, Air Intake					1
-40	86728-025	• Elbow-MB-MJ90-20-16					2
-41	81002	• Fitting-MB-MJ8-10					1
-42	86911-008	• Stem 2" 90 32C4-39FL90					2
-43	86264-006	• Split Flange Code 61 32 SAE					2
-44	87162	• Bracket, Cooler Mount-LH					1
-45	87163	• Bracket, Cooler Mount-RH					1
-46	87194	• Assembly, Engine Wiring Harness (See Schematic Section, Page 11 for REF)					1
47	87595	• Mount, Muffler					1
48	87465	• Tube, Exhaust					1
49	87627	• Flange, Exhaust					1

DASH (-) ITEM NOT ILLUSTRATED

REVISION:



# HYDRAULIC PUMPS ASSEMBLY

**B50**  
**PARTS**  
GROUP 40  
FIGURE 02  
PAGE 01

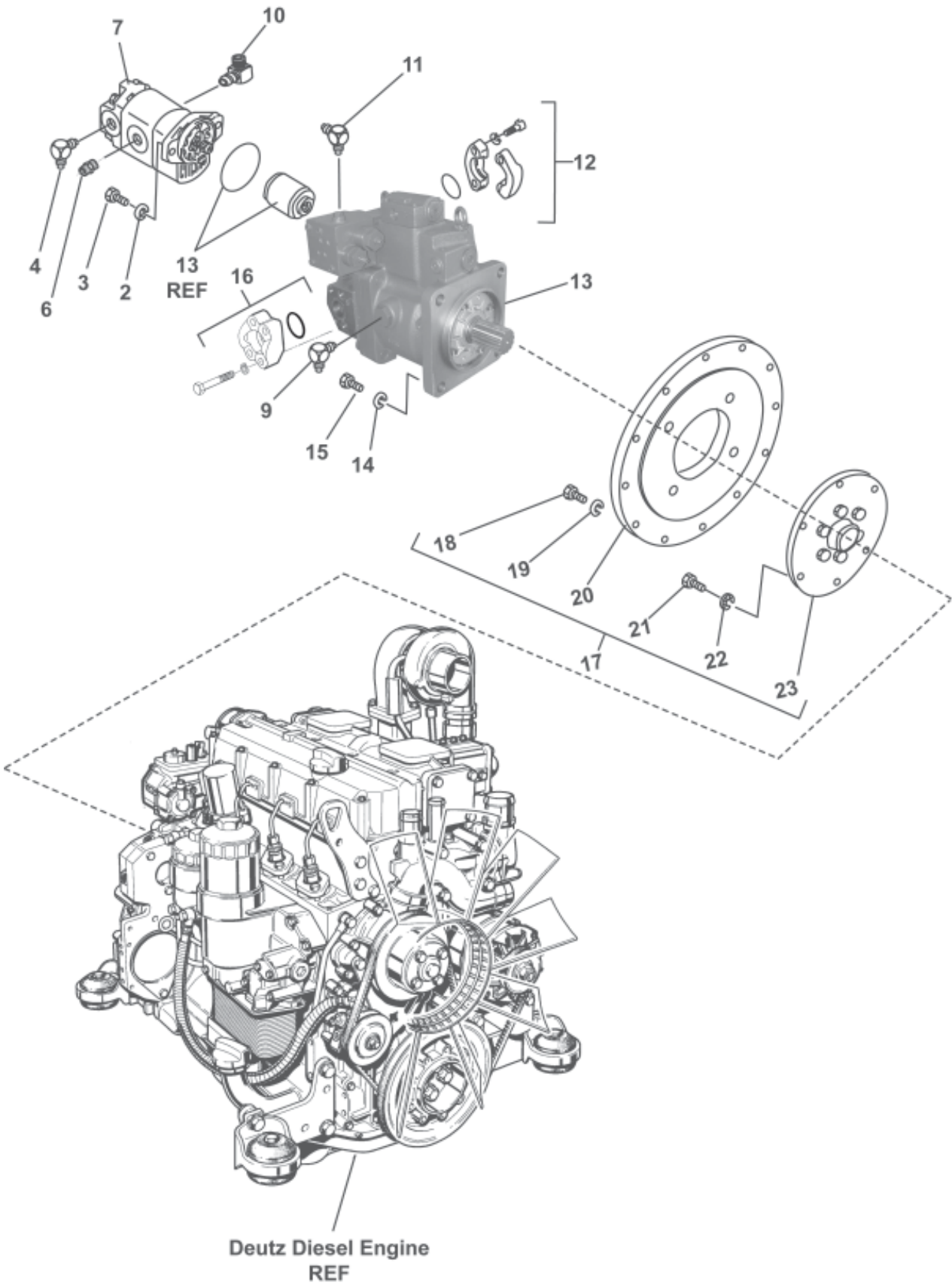

REVISION:



## HYDRAULIC PUMPS ASSEMBLY

**B50**  
**PARTS**  
GROUP 40  
FIGURE 02  
PAGE 02

ITEM NO.	REED'S PART NO.	DESCRIPTION					QTY
		1	2	3	4	5	
-1	40-02	Assembly, Hydraulic Pump (See Group 40, Figure 01 for NHA)					Ref
2		• Washer, Lock					2
3		• Bolt, Hex					2
4	86728-014	• Fitting, Elbow MB-MJ90-10-10					1
5	87153	• Assembly, Double Auxiliary Pump (See Group 40, Figure 04 for DET)					1
6	86900-017	• Fitting, Adaptor MB-MJ-10-10					1
7	86912-006	• Stem ML90-20-16					1
8	86911-009	• Stem ML90-40-40					1
9	NPN	• Fitting, Elbow MB-MJ90-12-10					1
10	86728-023	• Fitting, Elbow MB-MJ90-16-16					1
11	NPN	• Fitting, Elbow MB-MJ90-4-6					1
12	86264-007	• Kit, Split Flange-Code 61-40SAE					1
13	85124-004	• Assembly, Main Pump (See Group 40, Figure 05 for DET) (Also See Vendor Section, Figure 02 for REF)					1
14		• Washer, Lock (attaching parts)					4
15		• Bolt, Hex (attaching parts)					4
16	86265-003	• Kit, Split Flange-Code 62-20SAE					1
17	87360	• Assembly, Flywheel Coupling (Pump Drive)					1
18		• • Bolt, Hex					12
19		• • Washer, SPL					12
20		• • Plate, Flywheel					1
21		• • Screw					6
22		• • Washer					6
23		• • Drive, Flywheel					1

DASH (-) ITEM NOT ILLUSTRATED

REVISION:



# DOUBLE AUXILIARY PUMP ASSEMBLY

B50  
PARTS  
GROUP 40  
FIGURE 03  
PAGE 01

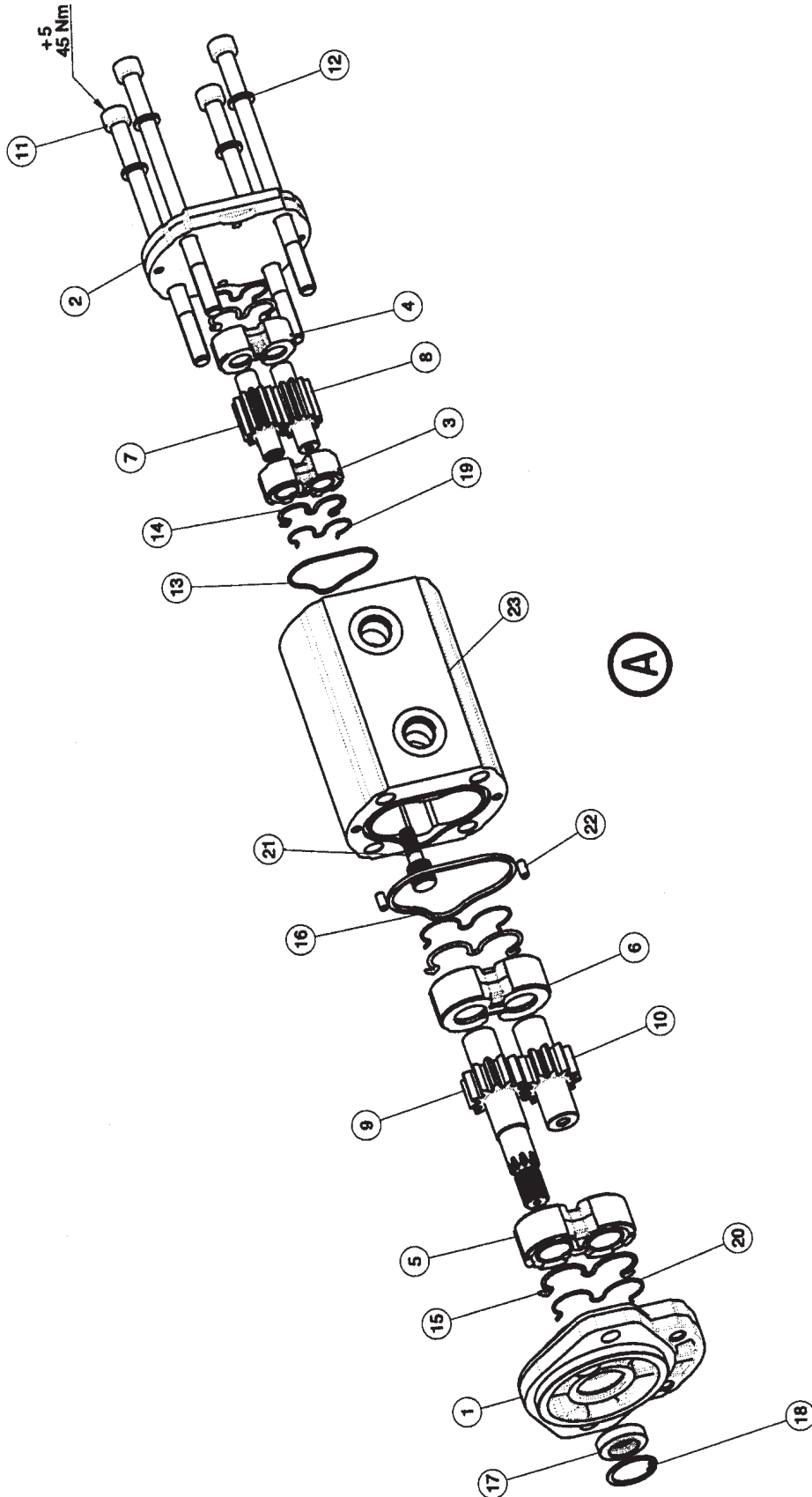

REVISION:





# DOUBLE AUXILIARY PUMP ASSEMBLY

**B50**  
**PARTS**  
GROUP 40  
FIGURE 03  
PAGE 02

ITEM NO.	REED'S PARTS NO.	DESCRIPTION	QTY
		1 2 3 4 5	
A	87153	Assembly, Double Auxiliary Pump (See Group 40, Figure 02 for NHA) (Also See Vendor Section, Figure 02 for REF)	Ref
1		• Cover, Front	1
2		• Cover, Twin Rear	1
3		• Plate, Thrust	1
4		• Plate, Thrust	1
5		• Plate, Thrust	1
6		• Plate, Thrust	1
7		• Gear, Drive	1
8		• Gear, Driven	1
9		• Shaft, Drive	1
10		• Shaft, Driven	1
11		• Screw	4
12		• Washer	4
13		• O-Ring	1
14		• Seal	2
15		• Seal	2
16		• Plate, Seal	1
17		• Seal, Shaft	1
18		• Ring	1
19		• Plate, Anti-Intrusion	2
20		• Ring, Back-Up	2
21		• Hub	1
22		• Pin, Dowel	2
23		• Body	1

REVISION:

## DOUBLE AUXILIARY PUMP ASSEMBLY

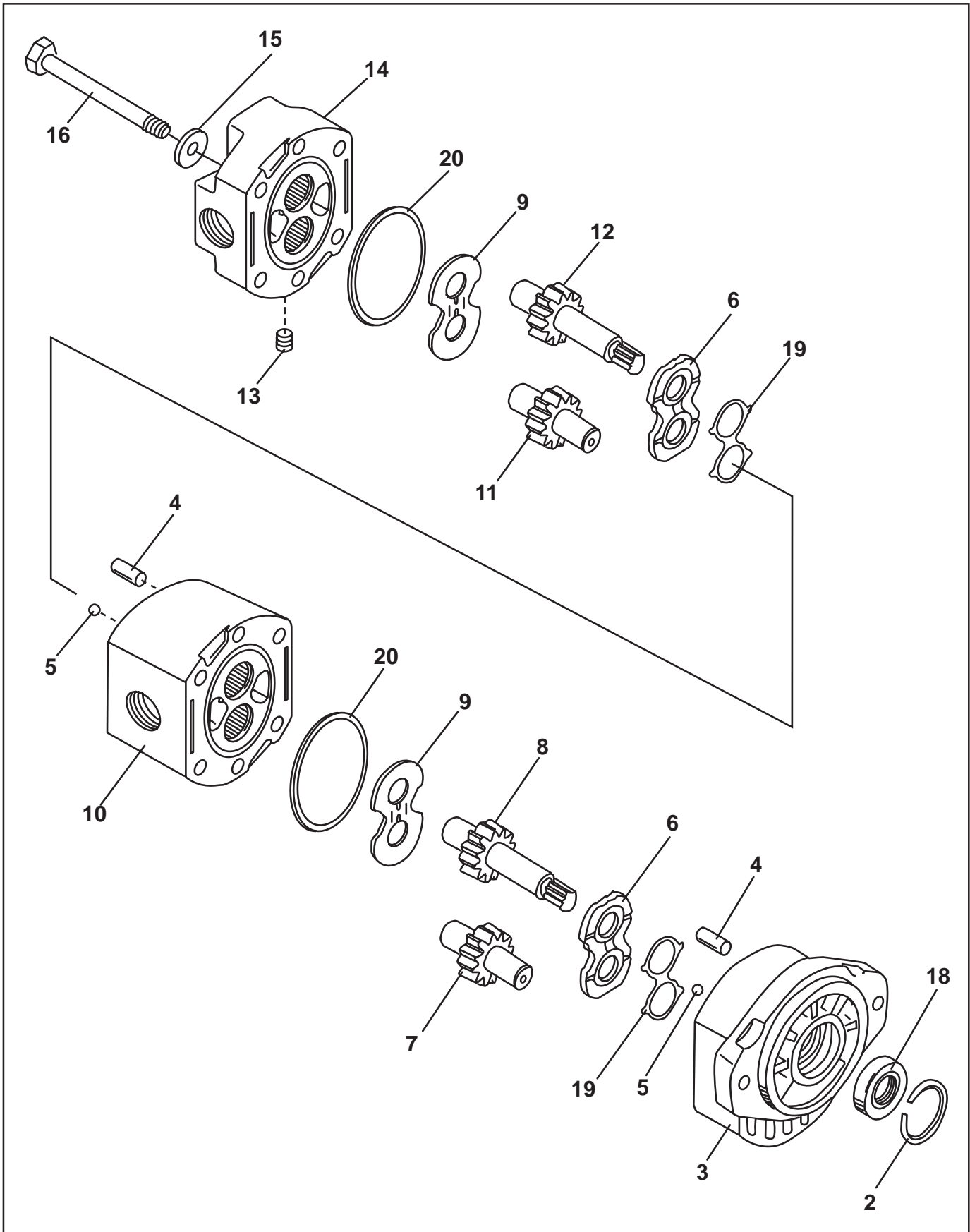

REVISION:



## DOUBLE AUXILIARY PUMP ASSEMBLY

**B50**  
**PARTS**  
GROUP 40  
FIGURE 04  
PAGE 02

ITEM NO.	REED'S PART NO.	DESCRIPTION					QTY
		1	2	3	4	5	
-1	73156	• Assembly, Double Auxiliary Pump (See Group 40, Figure 02 for NHA)					Ref
2		• Retainer					1
3		• Assembly, Body					1
4		• Pin, Dowel					4
5		• Bearing, Ball					4
6		• Plate, Wear					2
7		• Gear, Driven					1
8		• Gear, Drive					1
9		• Plate, Thrust					2
10		• Assembly, Middle Body					1
11		• Gear, Rear Driven					1
12		• Cover, Rear Drive					1
13		• Plug, Pipe					1
14		• Assembly, Cover					1
15		• Washer, Flat (attaching parts)					4
16		• Screw, Hex (attaching parts)					4
-17	79598	• Kit, Seal					1
18		• • Seal, Shaft					1
19		• • Rubber, Space					2
20		• • Ring, Square Cut					2

DASH (-) ITEM NOT ILLUSTRATED

REVISION:



# KAWASAKI MODEL K3VL MAIN HYDRAULIC PUMP ASSEMBLY

**B50**  
**PARTS**  
GROUP 40  
FIGURE 05  
PAGE 01

Attached Drawing No.1 Exploded Drawing

## Main Pump

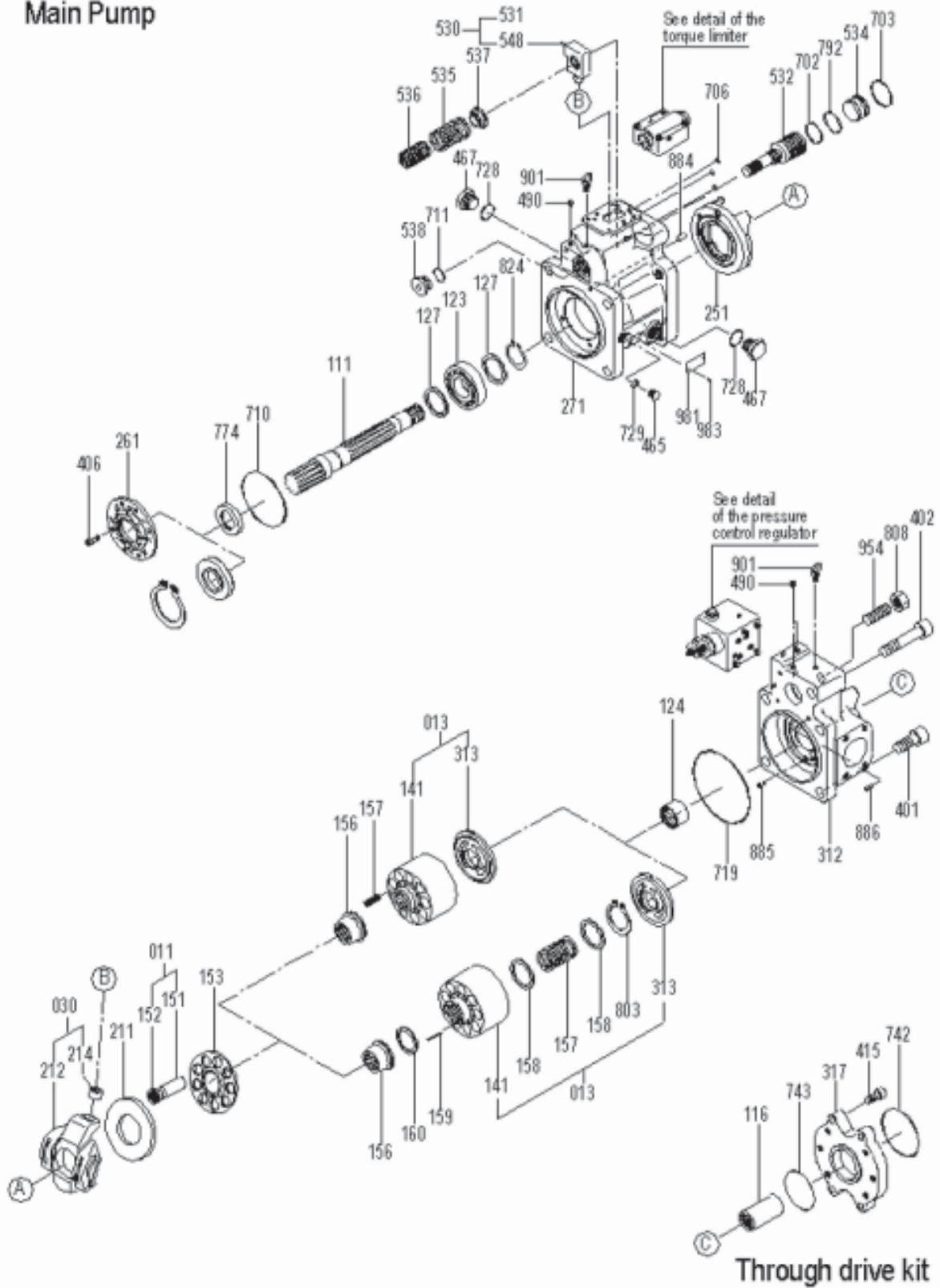

REVISION:



**KAWASAKI MODEL K3VL  
MAIN HYDRAULIC PUMP ASSEMBLY**

**B50  
PARTS  
GROUP 40  
FIGURE 05  
PAGE 02**

ITEM NO.	REED'S PART NO.	DESCRIPTION					QTY
		1	2	3	4	5	
-1	85124-004	• Assembly, Main Pump (See Group 40, Figure 02 for NHA) (Also See Vendor Section, Figure 02 for Complete Info)					Ref
2							
3							
4							
5							
6							
7							
8							
9							
23							
33							
34							
44							
45							
46							
47							
-48							
49							
50							
51							
52							

DASH (-) ITEM NOT ILLUSTRATED

REVISION:



# BATTERY MOUNT ASSEMBLY

**B50**  
**PARTS**  
GROUP 40  
FIGURE 06  
PAGE 01

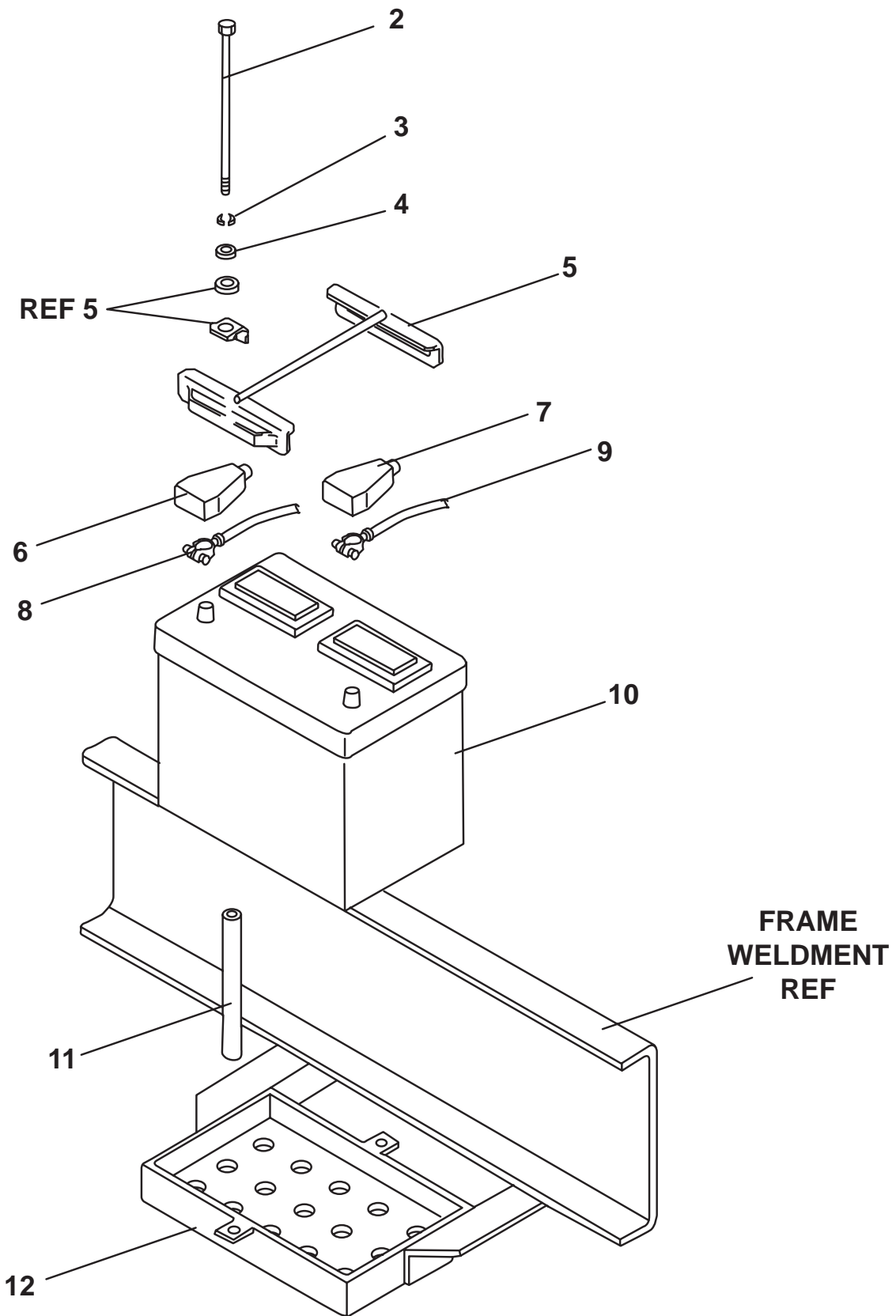

REVISION:



# BATTERY MOUNT ASSEMBLY

**B50**  
**PARTS**  
GROUP 40  
FIGURE 06  
PAGE 02

ITEM NO.	REED'S PART NO.	DESCRIPTION	QTY
		1 2 3 4 5	
-1	40-06	Assembly, Battery Mounting (See Group 40, Figure 01 for NHA)	Ref
2		• Bolt, Hex	2
3		• Washer, Lock	2
4		• Washer, Flat	2
5	72945	• Holder, Battery Dopwn	1
6	77720	• Insulator, Negative Battery (Black)	1
7	77719	• Insulator, Positive Battery (Red)	1
8	75116	• Cable, Negative Battery (Black)	1
9	72016	• Cable, 24 Inch Long Positive Battery (Red)	1
10	77075	• Battery, 12 VDC	1
11	73753	• Spacer, Battery Mounting	2
12	72954	• Weldment, Battery Box	1
-13	72014	• Cable, 36 Inch Long Battery Top	1
-14	85348	• Connector, SPNO 12 VDC	1

DASH (-) ITEM NOT ILLUSTRATED

REVISION:



**TRAILER MOUNTED PUMP MODEL  
B50 ILLUSTRATED PARTS MANUAL**

**B50  
PARTS  
GROUP 40  
FIGURE 07  
PAGE 01**

**THIS PAGE INTENTIONALLY LEFT BLANK**





# TRAILER MOUNTED PUMP MODEL B50 GROUP 50 CONTROLS INSTALLATION

**B50**  
**PARTS**  
GROUP 50  
FIGURE 00  
PAGE 00

**REED** TRAILER MOUNTED CONCRETE PUMP MODEL **B50** ILLUSTRATED PARTS MANUAL GROUP 50 CONTROLS INSTALLATION CONTAINS THE FOLLOWING FIGURES:

<b>FIGURE</b>	<b>00</b>	TABLE OF CONTENTS
<b>FIGURE</b>	<b>01</b>	CONTROLS INSTALLATION
<b>FIGURE</b>	<b>02</b>	CONTROL BOX ASSEMBLY
<b>FIGURE</b>	<b>03</b>	50 FEET CABLE REMOTE CONTROL ASSEMBLY
<b>FIGURE</b>	<b>04</b>	100 FEET CABLE REMOTE CONTROL ASSEMBLY
<b>FIGURE</b>	<b>05</b>	RADIO REMOTE CONTROL ASSEMBLY

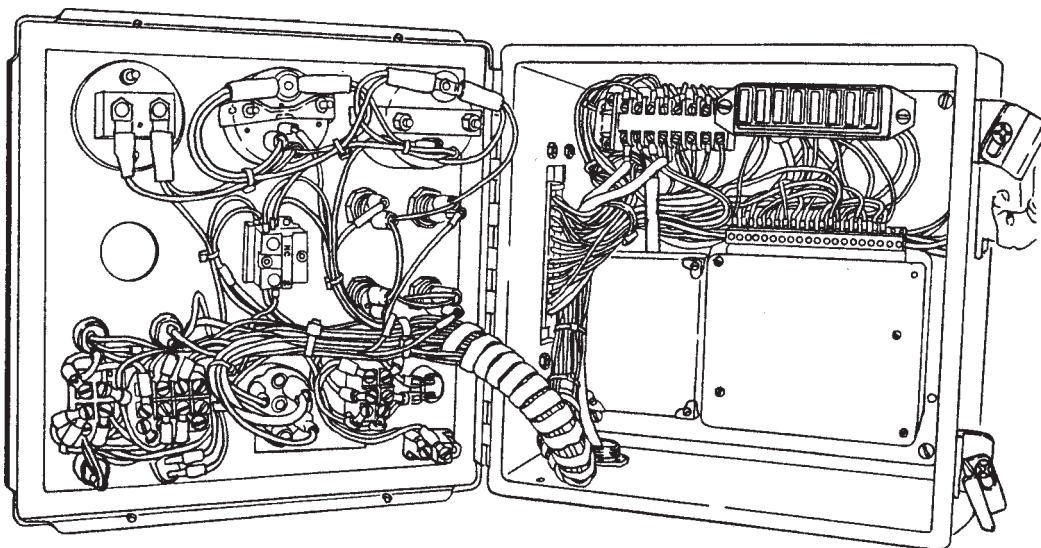

REVISION:



# CONTROL INSTALLATION

**B50**  
**PARTS**  
GROUP 50  
FIGURE 01  
PAGE 01

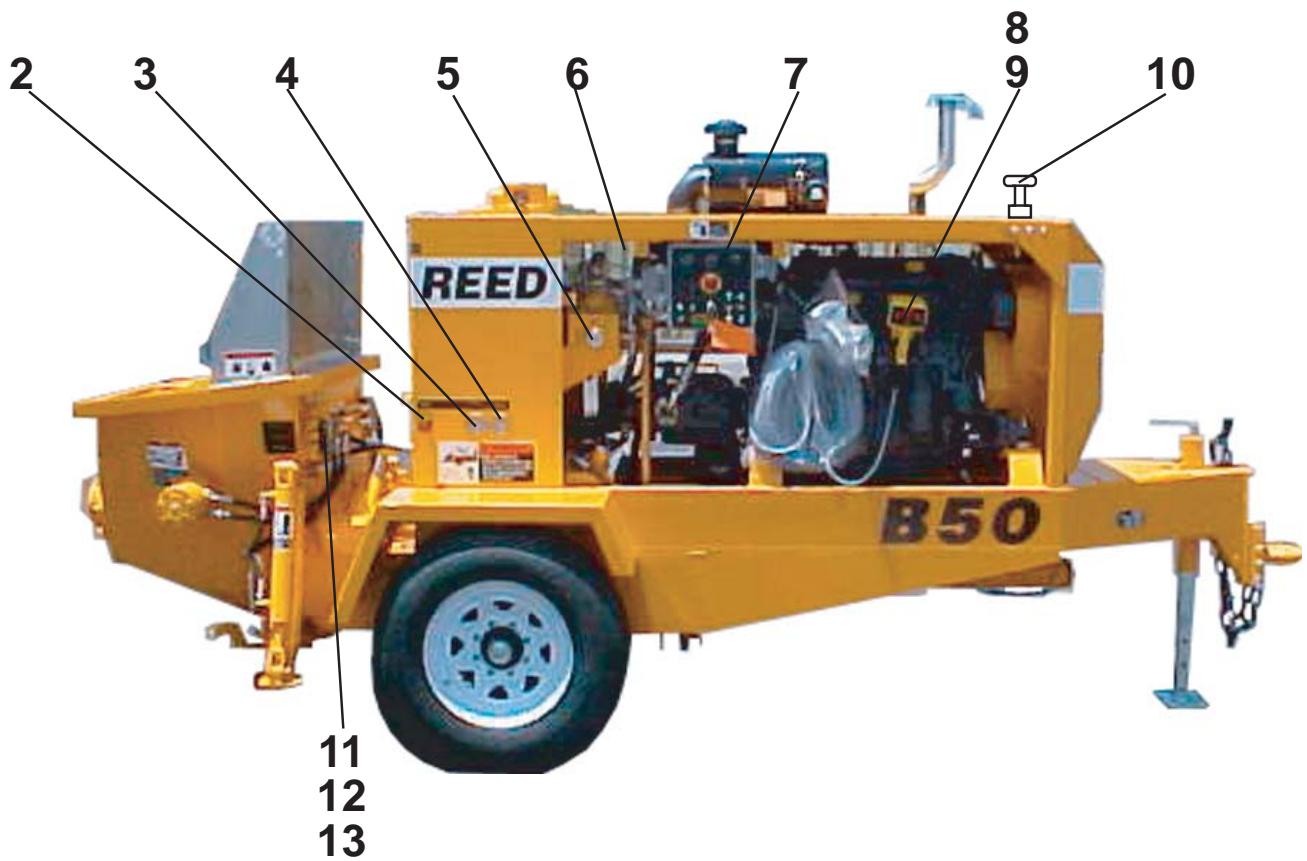

REVISION:



# CONTROL INSTALLATION

**B50**  
**PARTS**  
GROUP 50  
FIGURE 01  
PAGE 02

ITEM NO.	REED'S PART NO.	DESCRIPTION					QTY
		1	2	3	4	5	
-1	50-01	Installation, Control (See Group 10, Figure 01, 02, 03, and 04 for NHA)					Ref
2	78201	• Cable, Throttle Control (See Group 40, Figure 01 for REF)					1
3	70366	• Gauge, 3,000 PSI Hydraulic (See Group 30, Figure 02 for REF)					1
4	74562	• Gauge, 6,000 PSI Hydraulic (See Group 30, Figure 02 for REF)					1
5	85697	• Cartridge, Flow Control Valve (See Group 30, Figure 07 for REF)					1
6	800347	• Horn, 12 V					1
7	85358	• Assembly, Control Box (See Group 50, Figure 02 for DET)					1
8	85359	• Assembly, 50 Feet Cable Remote Control (See Group 50, Figure 03 for DET)					1
9	85359A	• Assembly, 100 Feet Cable Remote Control (See Group 50, Figure 04 for DET)					1
10	85818	• Assembly, Radio Remote Control (Optional Item) (See Group 50, Figure 05 for DET)					1
11	20-09	• Assembly, 3 Spool Control Valve (Optional Item) (See Group 20, Figure 08 for REF)					1
12	80-16	• Assembly, 1 Spool Control Valve (Optional Item) (See Group 80, Figure 16 for REF)					1
13	80-18	• Assembly, 2 Spool Control Valve (Optional Item) (See Group 80, Figure 18 for REF)					1

DASH (-) ITEM NOT ILLUSTRATED

REVISION:

## CONTROL BOX ASSEMBLY

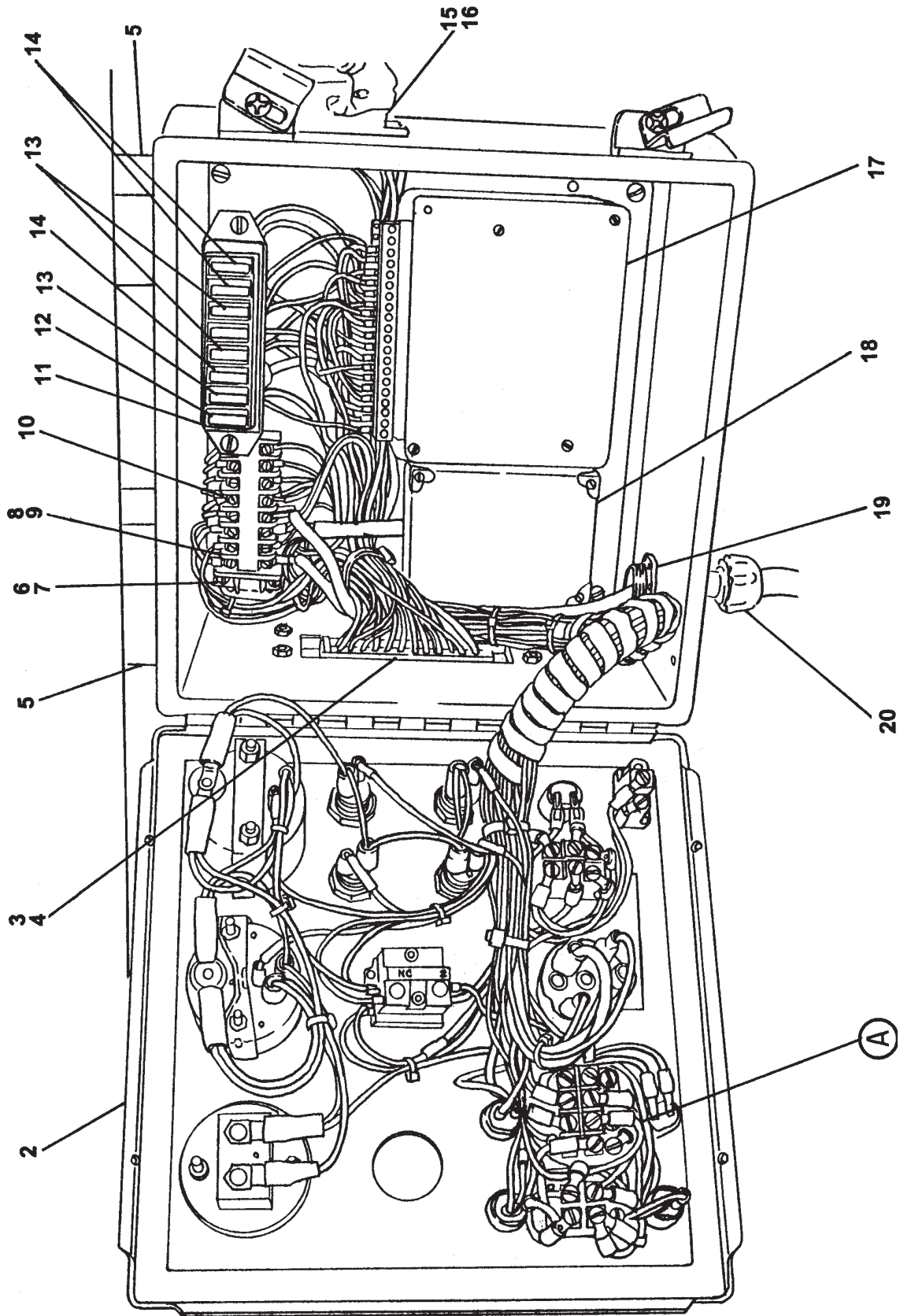



# CONTROL BOX ASSEMBLY

**B50**  
**PARTS**  
GROUP 50  
FIGURE 02  
PAGE 02

ITEM NO.	REED'S PART NO.	DESCRIPTION					QTY
		1	2	3	4	5	
-1	85358	Assembly, Control Box (See Group 50, Figure 01 for NHA)					Ref
2	85400	• Box, Control					1
3	78696	• Insert, Connector					1
4	78697	• Base, Connector					1
5	73748	• Bumper					4
6	75654	• End, Barrier					1
7	72821	• Rail, 0.333 Feet Barrier					1
8	72820	• Terminal					8
9	72824	• Jumper					2
10	85354	• Block, Fuse					1
11	85419	• Stand Off					1
12	800447	• Fuse, 25					1
13	800449	• Fuse, 10					4
14	90392	• Fuse, 5					3
15	79963	• Insert, Connector					1
16	79965	• Base, Connector					1
17	85596	• Box, Black					1
18	85334	• Box, Pump Black					1
19	10528	• Nut					1
20	10523	• Relief, Strain					1

DASH (-) ITEM NOT ILLUSTRATED

REVISION:

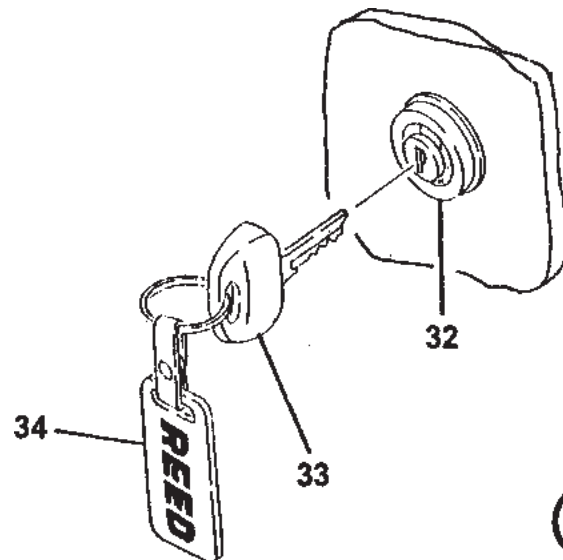



## CONTROL BOX ASSEMBLY

**B50**  
**PARTS**  
GROUP 50  
FIGURE 02  
PAGE 04

ITEM NO.	REED'S PART NO.	DESCRIPTION					QTY
		1	2	3	4	5	
21	78687	• Tachometer					1
22	78203	• Gauge, Water Temperature					1
23	74240	• Meter, Engine Hour					1
24	85342	• Operator, Emergency Stop					1
25	85343	• Block, Contact					1
26	85344	• Bulb, Emergency Stop					1
27	85332	• Decal, Control Box					1
28	85355	• Pilot, Light					4
29	78563	• Switch, Local / Remote					1
30	72003	• Switch, Pump On / Reverse					1
31	85356	• Pilot, Light					1
32	71154	• Switch, Ignition					1
33	71155	• • Key (Pair)					1
34	72862	• Gauge, Proximity Switch					1
35	85346	• Switch, CYL A / CYL B					1
36	85347	• Switch, Horn / Reset					1
37	73775	• Indicator, Red Light 14 VDC					4
38	72022	• Bulb, Indicator					4
-39	85396	• Assembly, Engine Wiring Harness (See Schematic Section, Page 11 for REF)					1
-40	86533	• Assembly, Trailer Wiring Harnessw (See Schematic Section, Page 12 for REF)					1

DASH (-) ITEM NOT ILLUSTRATED

REVISION:



# 50 FEET CABLE REMOTE CONTROL ASSEMBLY

B50  
PARTS  
GROUP 50  
FIGURE 03  
PAGE 01

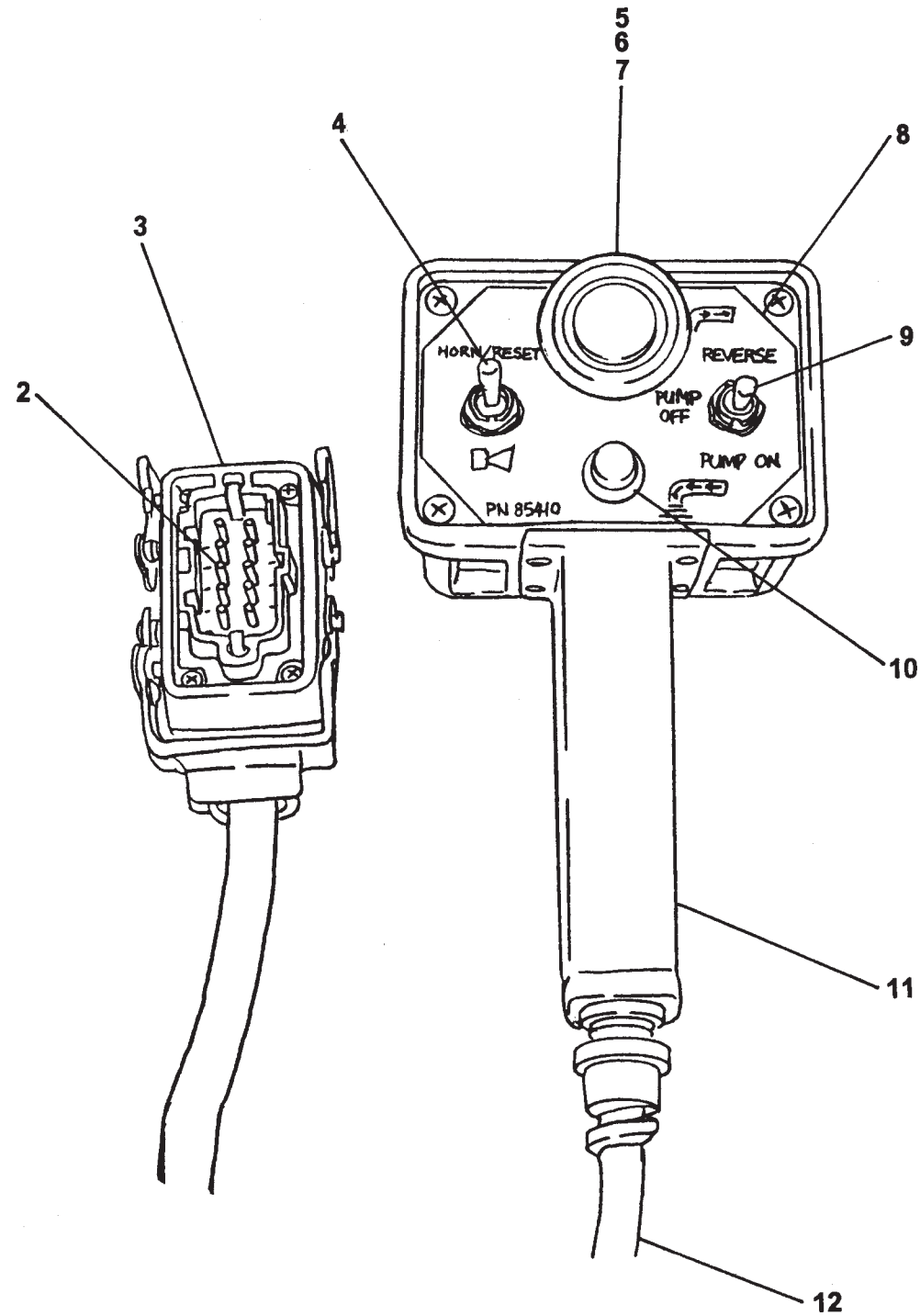

REVISION:





# 50 FEET CABLE REMOTE CONTROL ASSEMBLY

**B50**  
**PARTS**  
GROUP 50  
FIGURE 03  
PAGE 02

ITEM NO.	REED'S PART NO.	DESCRIPTION	QTY
		1 2 3 4 5	
-1	85359	Assembly, 50 Feet Cable Remote Control (See Group 50, Figure 01 for NHA)	Ref
2	79964	• Connector, Insert	1
3	79966	• Connector, Hood	1
4	85347	• Switch, Horn / Reset	1
5	85342	• Operator, Emergency Stop	1
6	85343	• Block, Contact	1
7	85344	• Bulb, Emergency Stop	1
8	85410	• Decal, Remote Control Box	1
9	72003	• Switch, Pump On / Reverse	1
10	85355	• Pilot, Light	1
11	71999	• Pistol, Grip	1
12	85620	• Cable, 50 Feet Remote Control	1

DASH (-) ITEM NOT ILLUSTRATED

REVISION:

# REED

## 100 FEET CABLE REMOTE CONTROL ASSEMBLY

B50  
PARTS  
GROUP 50  
FIGURE 04  
PAGE 01

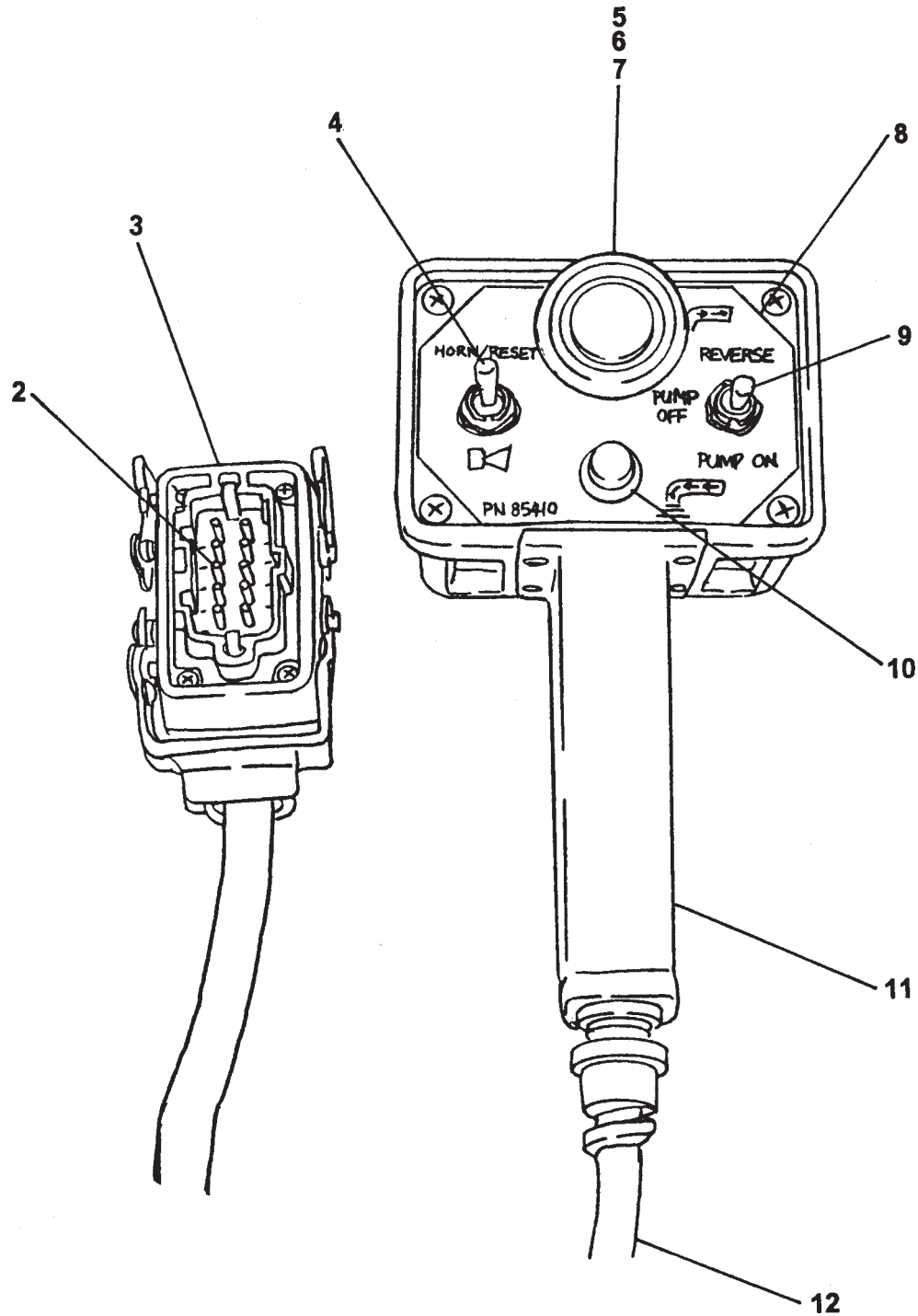

REVISION:



# 100 FEET CABLE REMOTE CONTROL ASSEMBLY

**B50**  
**PARTS**  
GROUP 50  
FIGURE 04  
PAGE 02

ITEM NO.	REED'S PART NO.	DESCRIPTION	QTY
		1 2 3 4 5	
-1	85359	Assembly, 100 Feet Cable Remote Control (See Group 50, Figure 01 for NHA)	Ref
2	79964	• Connector, Insert	1
3	79966	• Connector, Hood	1
4	85347	• Switch, Horn / Reset	1
5	85342	• Operator, Emergency Stop	1
6	85343	• Block, Contact	1
7	85344	• Bulb, Emergency Stop	1
8	85410	• Decal, Remote Control Box	1
9	72003	• Switch, Pump On / Reverse	1
10	85355	• Pilot, Light	1
11	71999	• Pistol, Grip	1
12	85816	• Cable, 100 Feet Remote Control	1

DASH (-) ITEM NOT ILLUSTRATED

REVISION:



# OPTIONAL RADIO REMOTE CONTROL ASSEMBLY

**B50**  
**PARTS**  
GROUP 50  
FIGURE 05  
PAGE 01



REVISION:



**OPTIONAL RADIO REMOTE  
CONTROL ASSEMBLY**

**B50  
PARTS  
GROUP 50  
FIGURE 05  
PAGE 02**

THIS GROUP 50, FIGURE PARTS NUMBER 85818,  
**OPTIONAL RADIO REMOTE CONTROL ASSEMBLY,**  
DETAIL PARTS LIST IS NOT AVAILABLE THIS REVISION.

REVISION:



**OPTIONAL RADIO REMOTE  
CONTROL ASSEMBLY**

**B50  
PARTS  
GROUP 50  
FIGURE 06  
PAGE 01**

THIS PAGE INTENTIONALLY LEFT BLANK



**TRAILER MOUNTED PUMP MODEL B50  
GROUP 60 PUMPING TRAIN INSTALLATION**

**B50  
PARTS  
GROUP 60  
FIGURE 00  
PAGE 01**

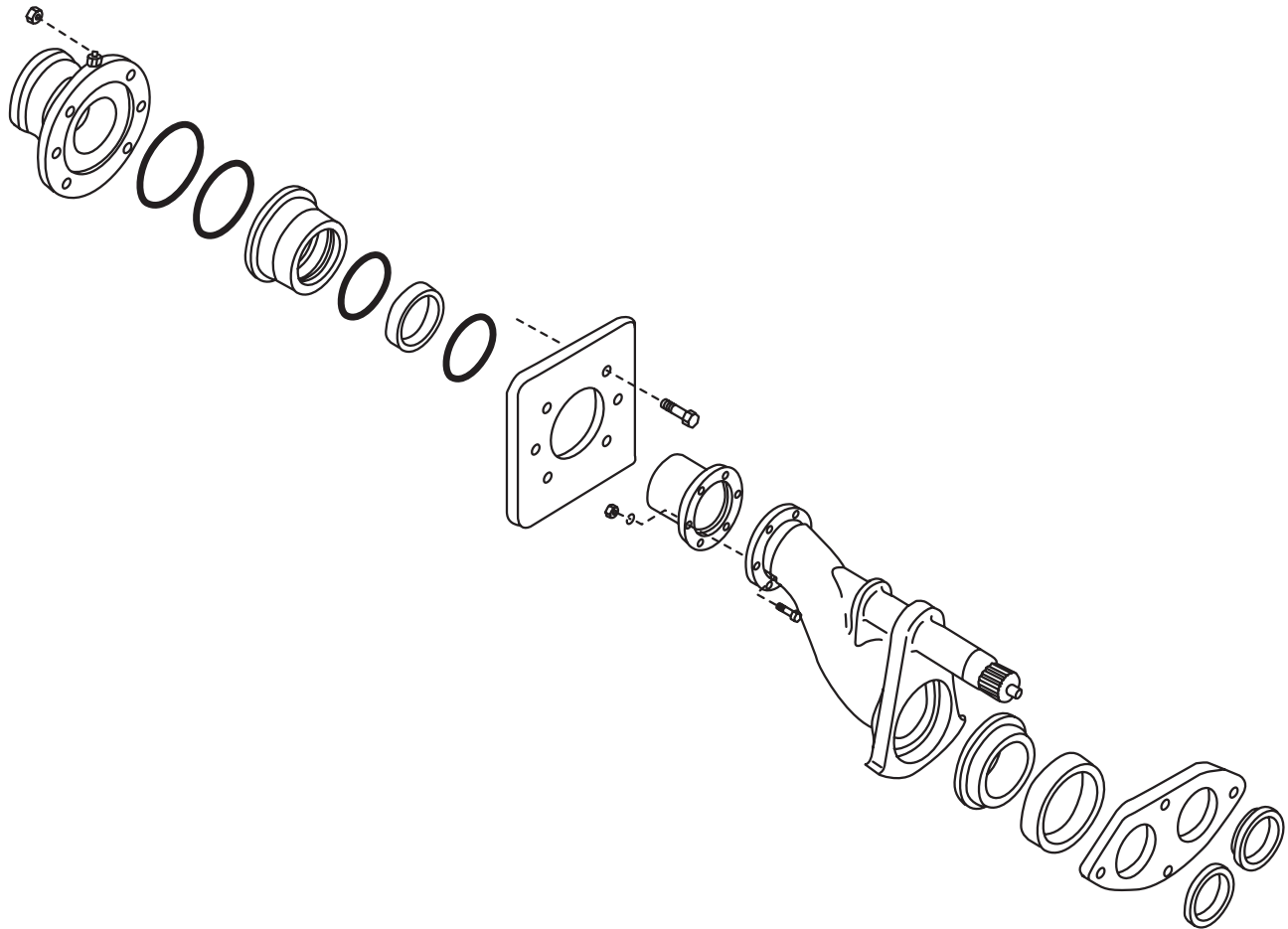

**REED TRAILER MOUNTED CONCRETE PUMP MODEL B50 ILLUSTRATED PARTS MANUAL GROUP 60 PUMPING TRAIN INSTALLATION CONTAINS THE FOLLOWING FIGURES:**

- FIGURE 00** TABLE OF CONTENTS
- FIGURE 01** SINGLE SHIFT PUMPING TRAIN INSTALLATION
- FIGURE 02** DUAL SHIFT PUMPING TRAIN INSTALLATION
- FIGURE 03** SINGLE SHIFT SWING VALVE ASSEMBLY
- FIGURE 04** DUAL SHIFT SWING VALVE ASSEMBLY
- FIGURE 05** SINGLE SHIFT SWING RAM CYLINDER SUBASSEMBLY
- FIGURE 06** DUAL SHIFT SWING RAM CYLINDER SUBASSEMBLY
- FIGURE 07** MATERIAL CYLINDER ASSEMBLY
- FIGURE 08** FLUSHBOX ASSEMBLY
- FIGURE 09** HYDRAULIC DRIVE CYLINDER ASSEMBLY
- FIGURE 10** HYDRAULIC DRIVE CYLINDER SUBASSEMBLIES

REVISION:



# SINGLE SHIFT PUMPING TRAIN INSTALLATION

**B50**  
**PARTS**  
GROUP 60  
FIGURE 01  
PAGE 01

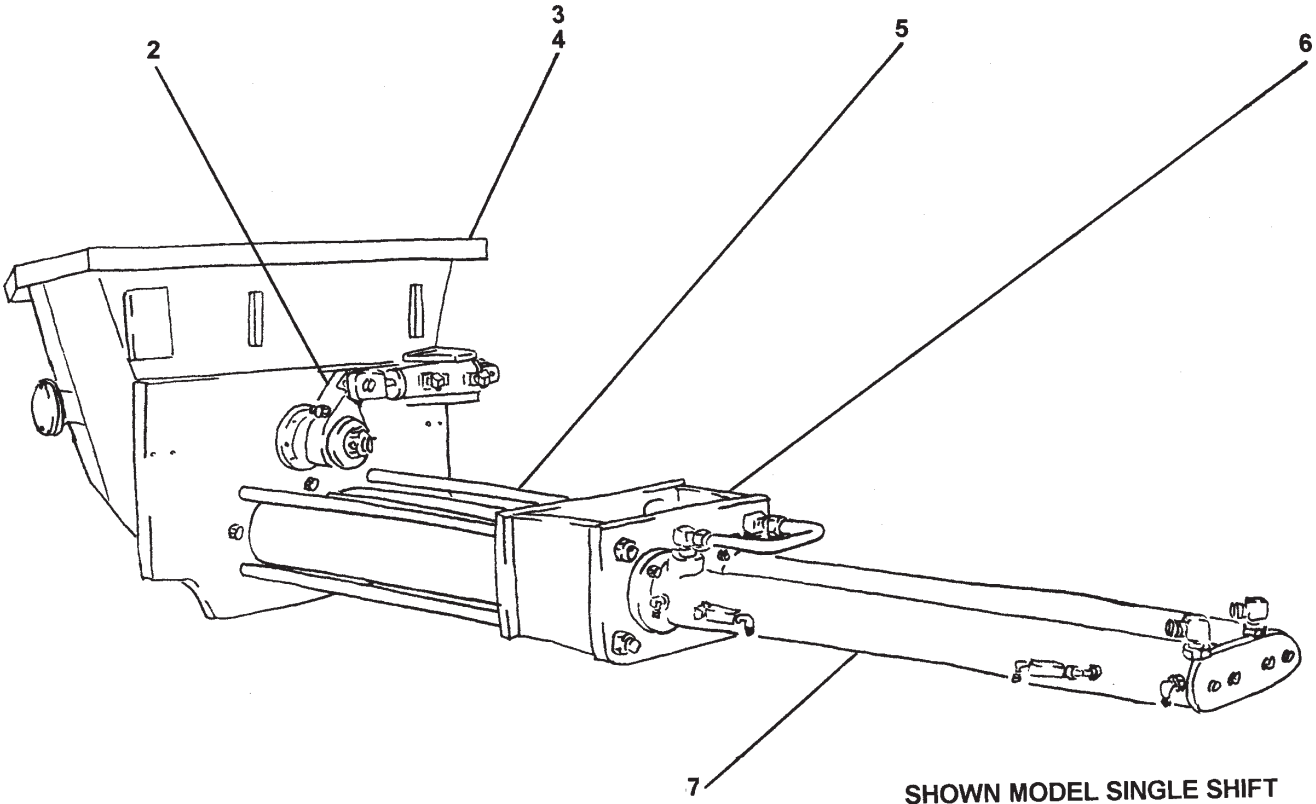

SHOWN MODEL SINGLE SHIFT  
STANDARD HOPPER UNIT

REVISION:





# SINGLE SHIFT PUMPING TRAIN INSTALLATION

**B50**  
**PARTS**  
GROUP 60  
FIGURE 01  
PAGE 02

ITEM NO.	REED'S PART NO.	DESCRIPTION	QTY
		1 2 3 4 5	
-1	60-01	Installation, Single Shift Pumping Train (See Group 10, Figure 01 and Figure 03 for NHA)	Ref
2	60-03	• Assembly, Single Shift Swing Valve (See Group 60, Figure 03 for DET)	1
3	20-01	• Installation, Standard Hopper (See Group 20, Figure 01 for REF)	Ref
4	20-02	• Installation, Harsh Mix Hopper (See Group 20, Figure 02 for REF)	Ref
5	86309	• Assembly, Material Cylinder (See Group 60, Figure 07 for DET)	1
6	60-08	• Assembly, Flushbox (See Group 60, Figure 08 for DET)	1
7	86304	• Assembly, Hydraulic Drive Cylinder (See Group 60, Figure 09 for DET)	1

DASH (-) ITEM NOT ILLUSTRATED

REVISION:

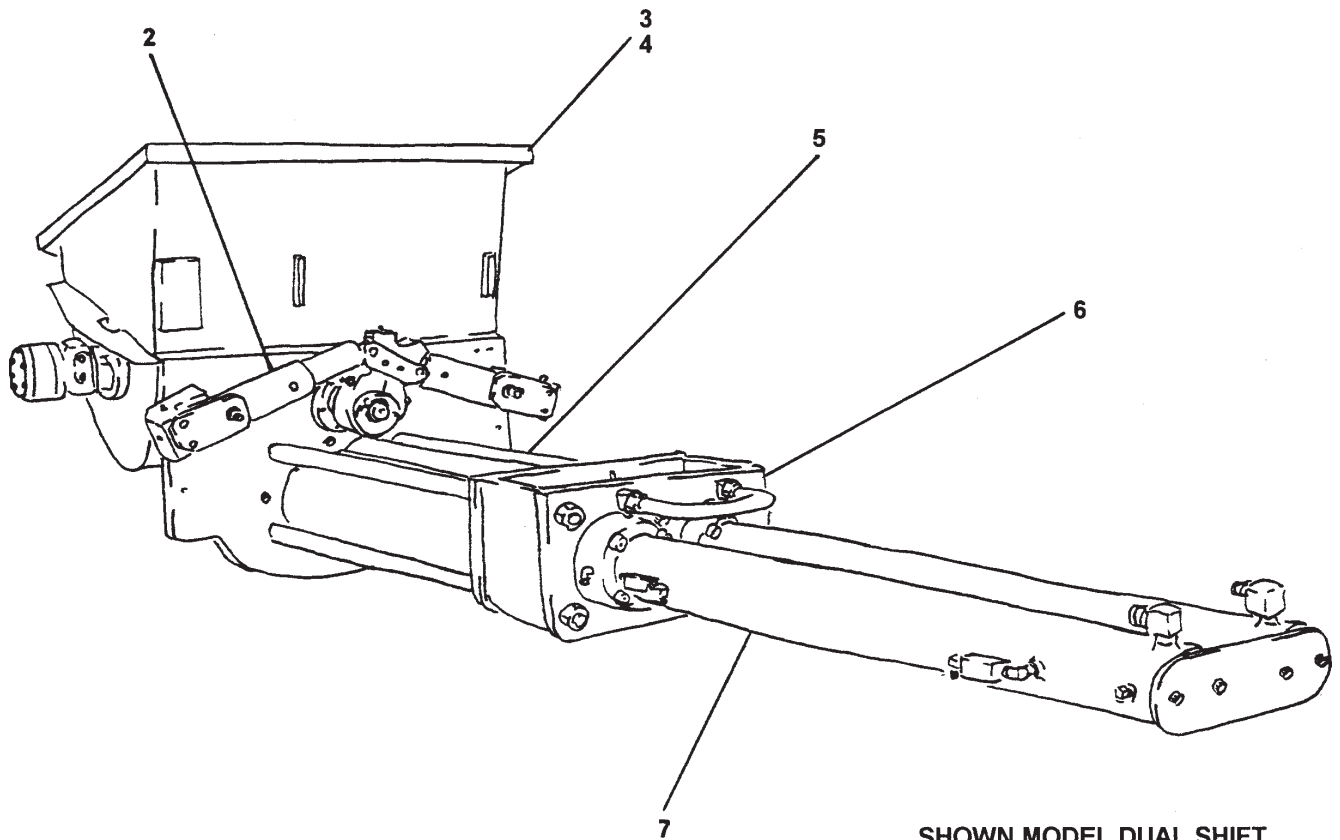

SHOWN MODEL DUAL SHIFT  
HARSH MIX HOPPER UNIT



# DUAL SHIFT PUMPING TRAIN INSTALLATION

**B50**  
**PARTS**  
GROUP 60  
FIGURE 02  
PAGE 02

ITEM NO.	REED'S PART NO.	DESCRIPTION	QTY
		1 2 3 4 5	
-1	60-02	Installation, Dual Shift Pumping Train (See Group 10, Figure 02 and Figure 04 for NHA)	Ref
2	60-04	• Assembly, Dual Shift Swing Valve (See Group 60, Figure 04 for DET)	1
3	20-01	• Installation, Standard Hopper (See Group 20, Figure 01 for REF)	Ref
4	20-02	• Installation, Harsh Mix Hopper (See Group 20, Figure 02 for REF)	Ref
5	86309	• Assembly, Material Cylinder (See Group 60, Figure 07 for DET)	1
6	60-08	• Assembly, Flushbox (See Group 60, Figure 08 for DET)	1
7	86304	• Assembly, Hydraulic Drive Cylinder (See Group 60, Figure 09 for DET)	1

DASH (-) ITEM NOT ILLUSTRATED

REVISION:

## SINGLE SHIFT SWING VALVE ASSEMBLY

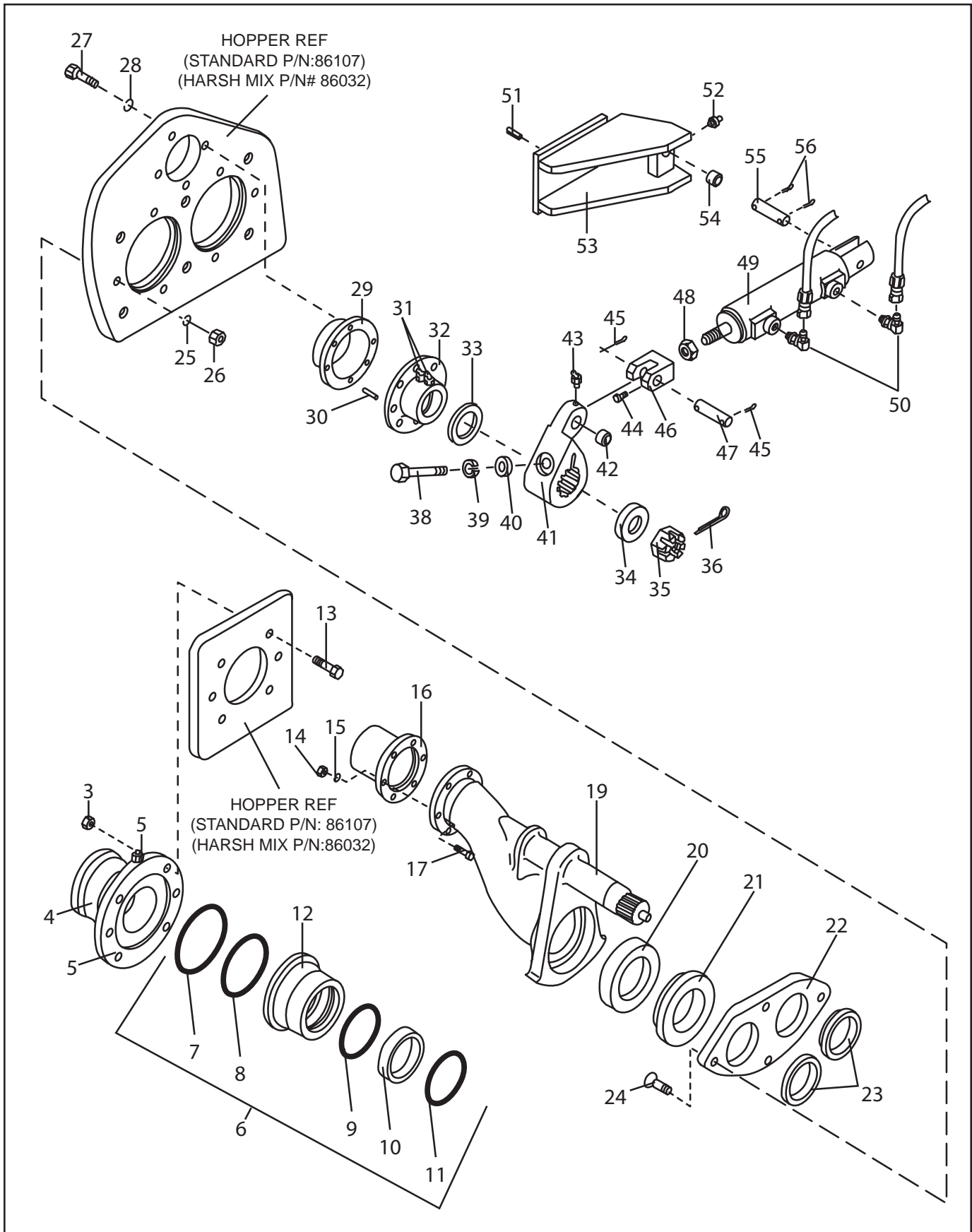

REVISION:



## SINGLE SHIFT SWING VALVE ASSEMBLY

**B50**  
**PARTS**  
GROUP 60  
FIGURE 03  
PAGE 02

ITEM NO.	REED'S PART NO.	DESCRIPTION					QTY
		1	2	3	4	5	
-1	60-03	Assembly, Single Shift Swing Valve (See Group 60, Figure 01 for NHA)					Ref
-2	86321	• Assembly, Outlet Group					1
3		• • Nut					6
4	72482	• • Outlet, Machine 5"					1
5		• • Fitting, Grease					2
6	79895	• • Kit, Outlet Seal					1
7	77761	• • • O-Ring, Large					1
8	77762	• • • O-Ring, Small					1
9	86504	• • • Seal, Modified Outlet Thick					1
10	77763	• • • Band, Guide					1
11	77765	• • • Seal, Outlet, Thick					1
12	72309	• • Housing, Outlet Seal					1
13		• • Bolt, Hex					6
14		• • Nut, Nylock (attaching parts)					6
15		• • Washer, Lock (attaching parts)					6
16	70042	• • Outlet, Chromed					1
17		• • Bolt, Hex (attaching parts)					6
-18	86317	• Assembly, Swing Tube Group					1
19	85965	• • Weldment, Harsh Swing Tube					1
20	86085	• • Seal, 6 Inch Single Lip					1
21	72310	• • Ring, 6 Inch Single Lip Wear					1
22	86031	• • Plate, Wear					1
23	86086	• • Ring, Anti Chip					2
24		• • Bolt, Flat Head					4
25		• • Washer, Lock					4
26		• • Nut, Hex					4
27		• • Bolt, Hex					6
28		• • Washer, Lock					6
29	85962	• • Seal, Flange Bearing					1
30		• • Pin, Dowel					1
31		• • Fitting, Grease 90					2
32	85133	• • Bearing, 3 Inch Spline Flange					1
33	85294	• • Washer, Thrust					1
34	85134	• • Spacer, Swing Tube Nut					1
35	70825	• • Nut, Swing Tube					1
36		• • Pin, Cotter					1
-37	86319	• Assembly, Swing Tube Single Shift Group					1
38		• • Bolt, Hex					1
39		• • Washer, Flat					1
40		• • Washer, Lock					1
41	85131	• • Crank, 3 Inch Single Splined Bell					1

**Continued On Next Page**

REVISION:

## SINGLE SHIFT SWING VALVE ASSEMBLY

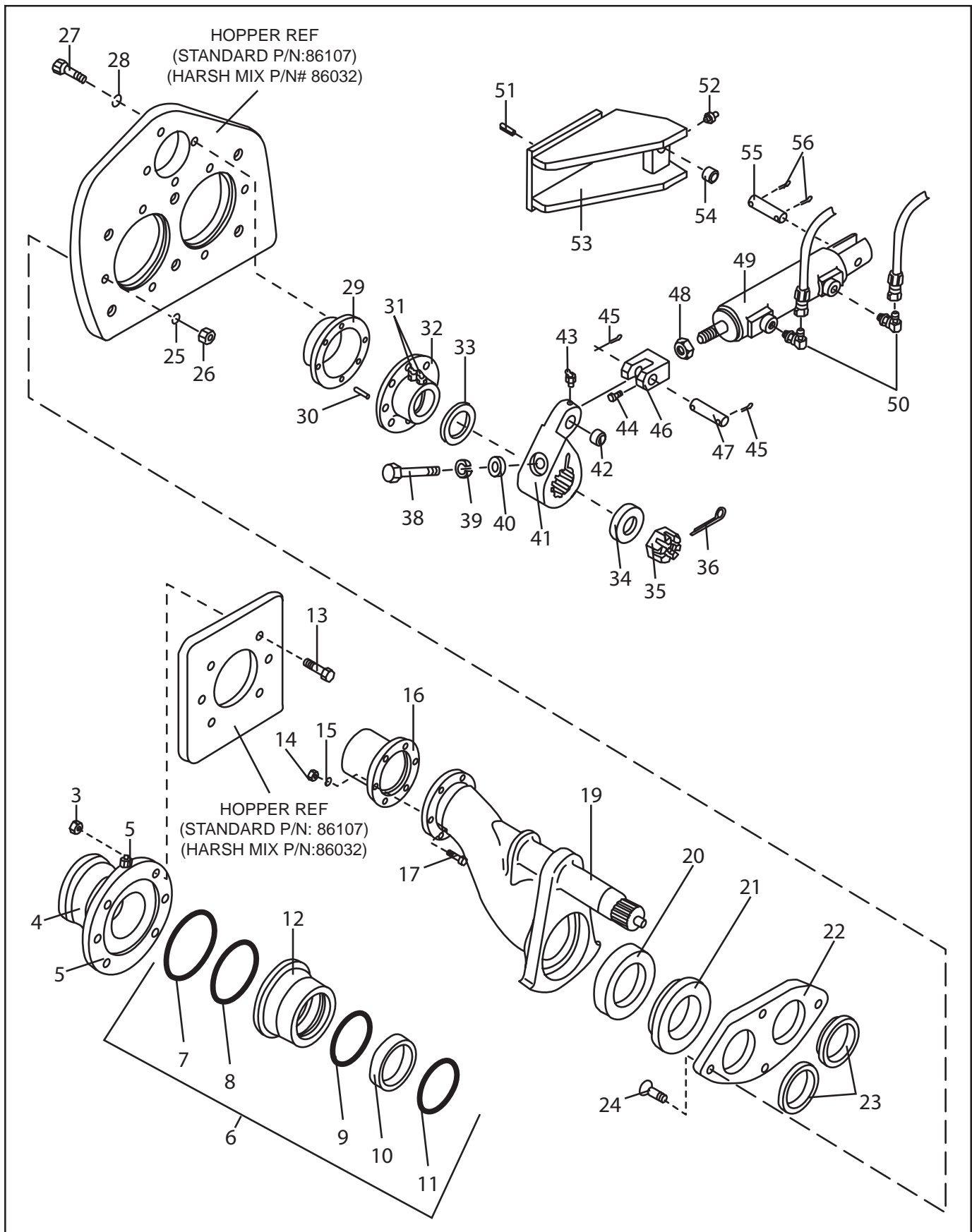

REVISION:



# SINGLE SHIFT SWING VALVE ASSEMBLY

**B50**  
**PARTS**  
GROUP 60  
FIGURE 03  
PAGE 04

ITEM NO.	REED'S PART NO.	DESCRIPTION					QTY
		1	2	3	4	5	
42	85538	• • •	Race, Inner			1	
43		• •	Fitting, Grease 90			1	
44		• •	Bolt, Hex			1	
45		• •	Pin, Cotter			2	
46	86135	• •	Clevis, Swing Ram Cylinder			1	
47	86150	• •	Pin, Clevis			1	
48		• •	Nut, Hex			1	
49	86221	• •	Assembly, Single Shift Swing Ram Cylinder (See Group 60, Figure 05 for DET)			1	
50		• •	Fitting, 90			2	
51	86052	• •	Pin, Spring			2	
52		• •	Fitting, Grease STR			1	
53	85947	• •	Bracket, Single Shift Swing Cylinder			1	
54	71011	• • •	Bushing, Shift Cylinder			1	
55	74207	• •	Pin, Clevis			1	
56		• •	Pin, Cotter			2	

DASH (-) ITEM NOT ILLUSTRATED

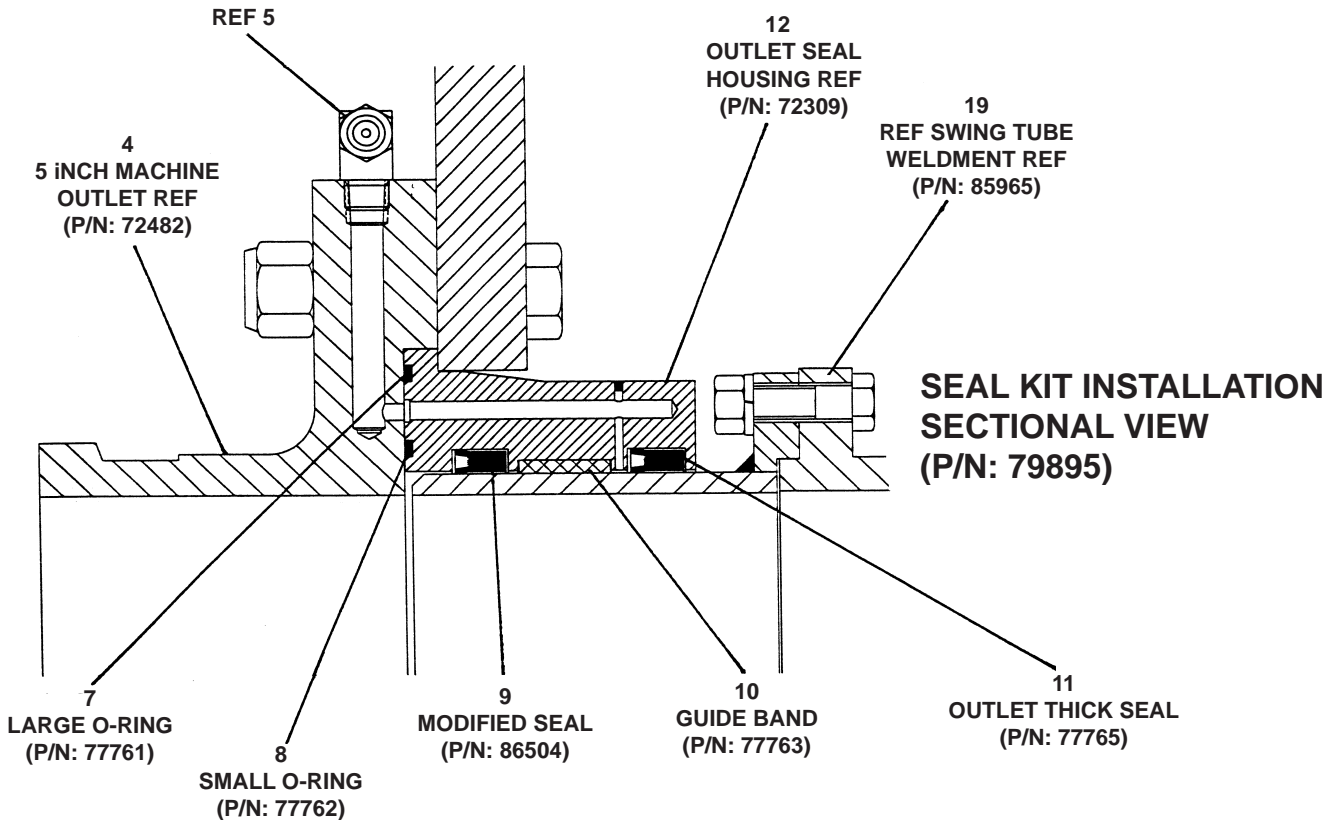

REVISION:



# DUAL SHIFT SWING VALVE ASSEMBLY

**B50**  
**PARTS**  
GROUP 60  
FIGURE 04  
PAGE 01

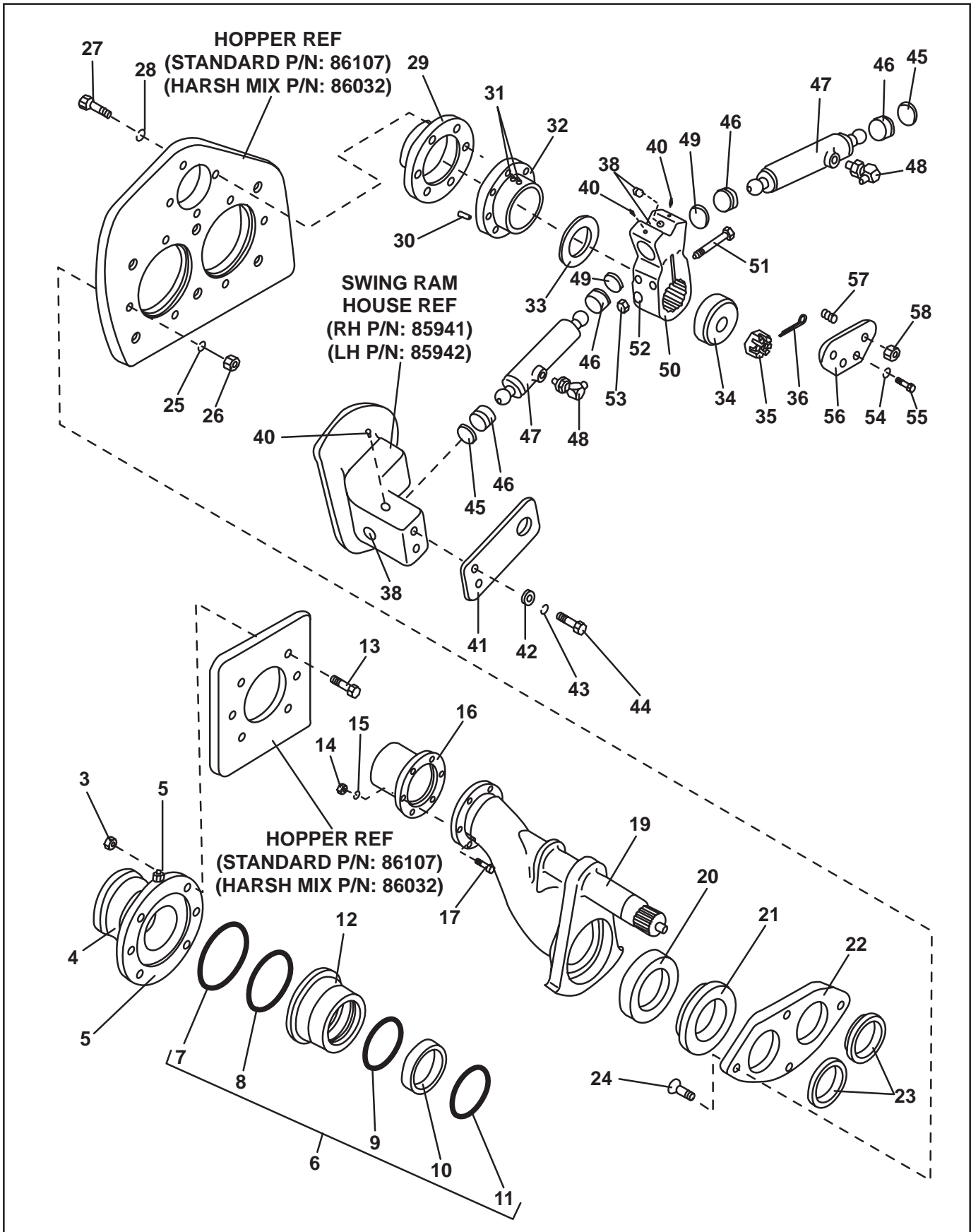

REVISION:





## DUAL SHIFT SWING VALVE ASSEMBLY

**B50**  
**PARTS**  
GROUP 60  
FIGURE 04  
PAGE 02

ITEM NO.	REED'S PART NO.	DESCRIPTION					QTY
		1	2	3	4	5	
-1	60-04	Assembly, Single Shift Swing Valve (See Group 60, Figure 02 for NHA)					Ref
-2	86321	• Assembly, Outlet Group					1
3		• • Nut					6
4	72482	• • Outlet, Machine 5"					1
5		• • Fitting, Grease					2
6	79895	• • Kit, Outlet Seal					1
7	77761	• • • O-Ring, Large					1
8	77762	• • • O-Ring, Small					1
9	86504	• • • Seal, Modified Outlet Thick					1
10	77763	• • • Band, Guide					1
11	77765	• • • Seal, Outlet, Thick					1
12	72309	• • Housing, Outlet Seal					1
13		• • Bolt, Hex					6
14		• • Nut, Nylock (attaching parts)					6
15		• • Washer, Lock (attaching parts)					6
16	70042	• • Outlet, Chromed					1
17		• • Bolt, Hex (attaching parts)					6
-18	86317	• Assembly, Swing Tube Group					1
19	85965	• • Weldment, Harsh Swing Tube					1
20	86085	• • Seal, 6 Inch Single Lip					1
21	72310	• • Ring, 6 Inch Single Lip Wear					1
22	86031	• • Plate, Wear					1
23	86086	• • Ring, Anti Chip					2
24		• • Bolt, Flat Head					4
25		• • Washer, Lock					4
26		• • Nut, Hex					4
27		• • Bolt, Hex					6
28		• • Washer, Lock					6
29	85962	• • Seal, Flange Bearing					1
30		• • Pin, Dowel					1
31		• • Fitting, Grease 90					2
32	85133	• • Bearing, 3 Inch Spline Flange					1
33	85294	• • Washer, Thrust					1
34	85134	• • Spacer, Swing Tube Nut					1
35	70825	• • Nut, Swing Tube					1
36		• • Pin, Cotter					1
-37	86320	• Assembly, Swing Tube Dual Shift Group					1
38		• • Plug, Pipe					4
39	86052	• • Pin, Spring					4
40		• • Fitting, Grease 90					2
41	86441	• • Retainer, Swing Ram					2

DASH (-) ITEM NOT ILLUSTRATED

REVISION:

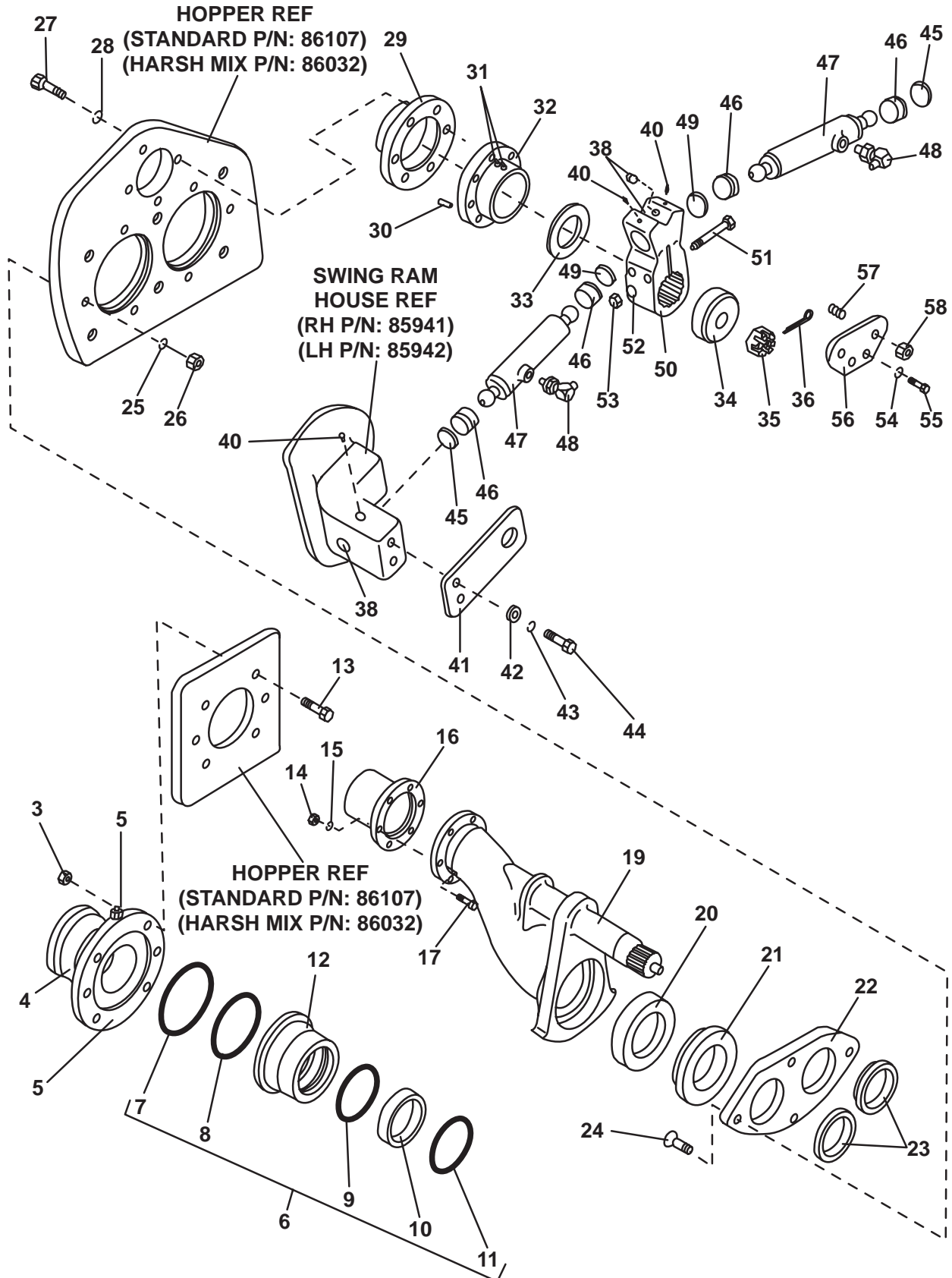



# DUAL SHIFT SWING VALVE ASSEMBLY

**B50**  
**PARTS**  
 GROUP 60  
 FIGURE 04  
 PAGE 04

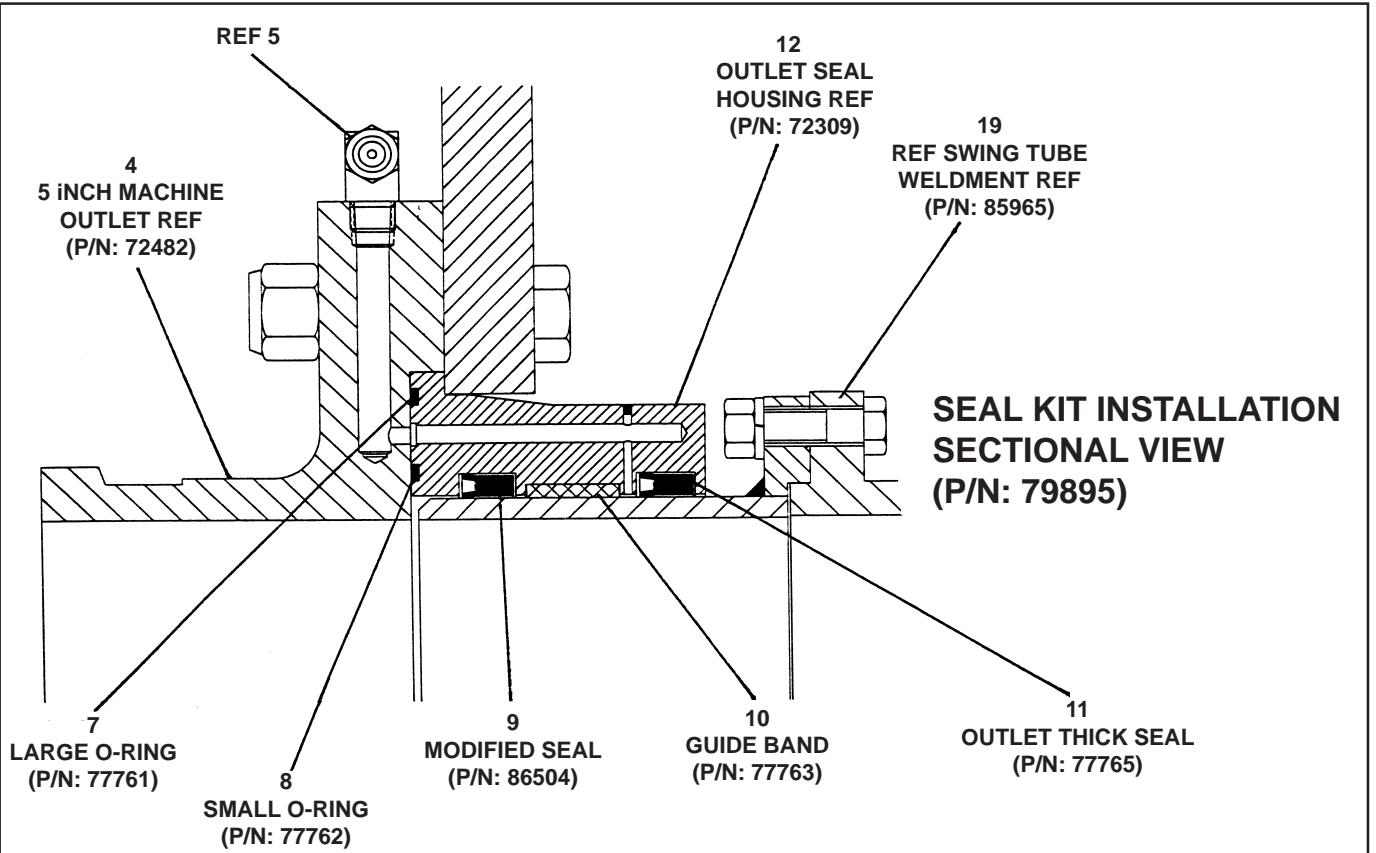

ITEM NO.	REED'S PART NO.	DESCRIPTION					QTY
		1	2	3	4	5	
42		••	Washer, Flat (attaching parts)				4
43		••	Washer, Lock (attaching parts)				4
44		••	Bolt, Hex (attaching parts)				4
45	75501	••	Spacer				2
46	76798	••	Socket, Ball				4
47	86220	••	Assembly, Dual Shift Swing Ram Cylinder (See Group 60, Figure 06 for DET)				1
48	75502	••	Fitting, 90				2
49	75501	••	Spacer				2
50	85956	••	Crank, 3 Inch Dual Shift Splined Bell				1
51		••	Bolt, Hex (attaching parts)				2
52		••	Washer, SPL Lock (attaching parts)				2
53		••	Nut, Hex (attaching parts)				2
54		••	Washer, Lock				2
55	86283	••	Bolt, Hex				2
56	86282	••	Retainer, Dual Shift Cylinder				1
57		••	Stud				2
58		••	Nut, Hex				2

DASH (-) ITEM NOT ILLUSTRATED

REVISION:

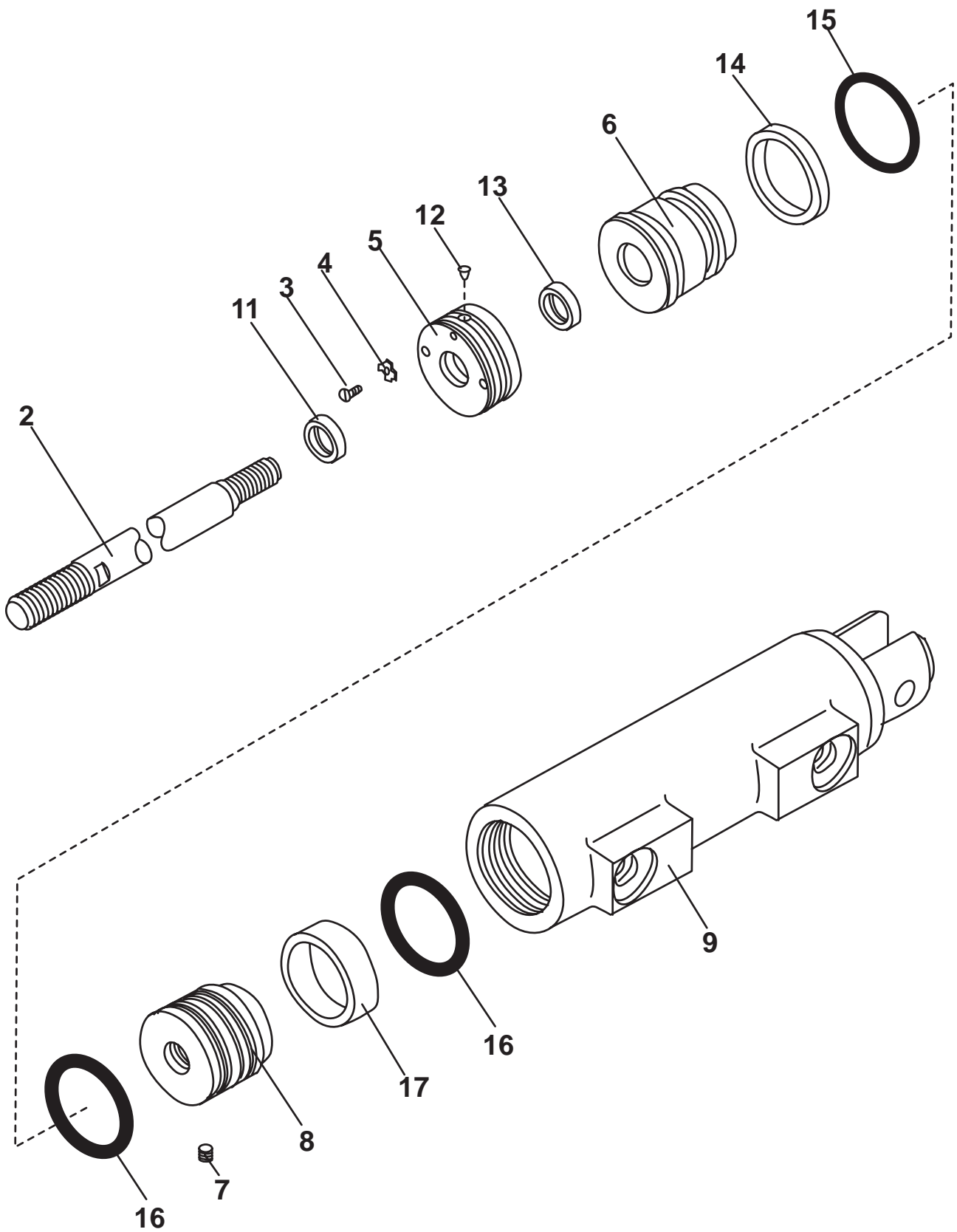



# SWING SHIFT SWING RAM CYLINDER ASSEMBLY

**B50**  
**PARTS**  
GROUP 60  
FIGURE 05  
PAGE 02

ITEM NO.	REED'S PART NO.	DESCRIPTION					QTY
		1	2	3	4	5	
-1	86221	Assembly, Single Shift Swing Ram Cylinder (See Group 60, Figure 03 for NHA)					Ref
2		• Rod, Cylinder					1
3		• Screw, Cap					1
4		• Washer, Lock					1
5		• Ring, Threaded					1
6		• Gland, Head					1
7		• Screw, Set					1
8		• Ring, Threaded					1
9		• Weldment, Cylinder Case					1
-10	86221-SK	• Kit, Seal					1
11		• • Wiper, Rod					1
12		• • Plug, Nylon					11
13		• • U-Cup					1
14		• • Seal, Back Up					1
15		• • O-Ring					1
16		• • Seal, Piston					2
17		• • Ring, Wear					1

DASH (-) ITEM NOT ILLUSTRATED

REVISION:

## DUAL SHIFT SWING RAM CYLINDER ASSEMBLY

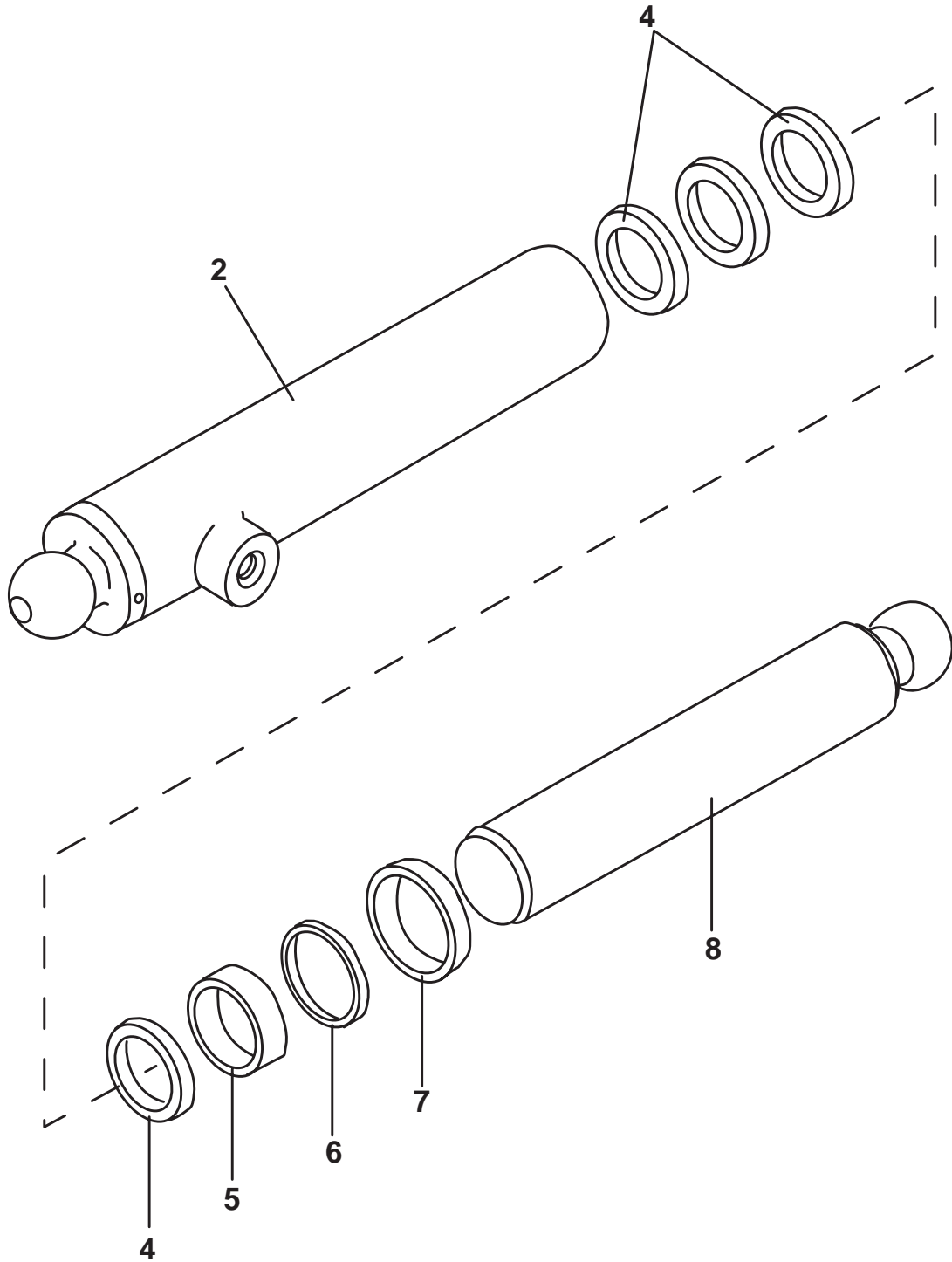



# DUAL SHIFT SWING CYLINDER ASSEMBLY

**B50**  
**PARTS**  
GROUP 60  
FIGURE 06  
PAGE 02

ITEM NO.	REED'S PART NO.	DESCRIPTION					QTY
		1	2	3	4	5	
-1	86220	Assembly, Swing Ram Cylinder (See Group 60, Figure 04 for NHA)					Ref
2		• Weldment, Cylinder Case					1
-3	86220-SK	• Kit, Seal					1
4		•• Ring, Wear					1
5		•• U-Cup					1
6		•• Ring, Back Up					4
7		•• Wiper, Rod					1
8		• Weldment, Cylinder Rod					1

DASH (-) ITEM NOT ILLUSTRATED

REVISION:

**HOPPER REF**  
(STANDARD P/N: 86107)  
(HARSH MIX P/N: 86032)

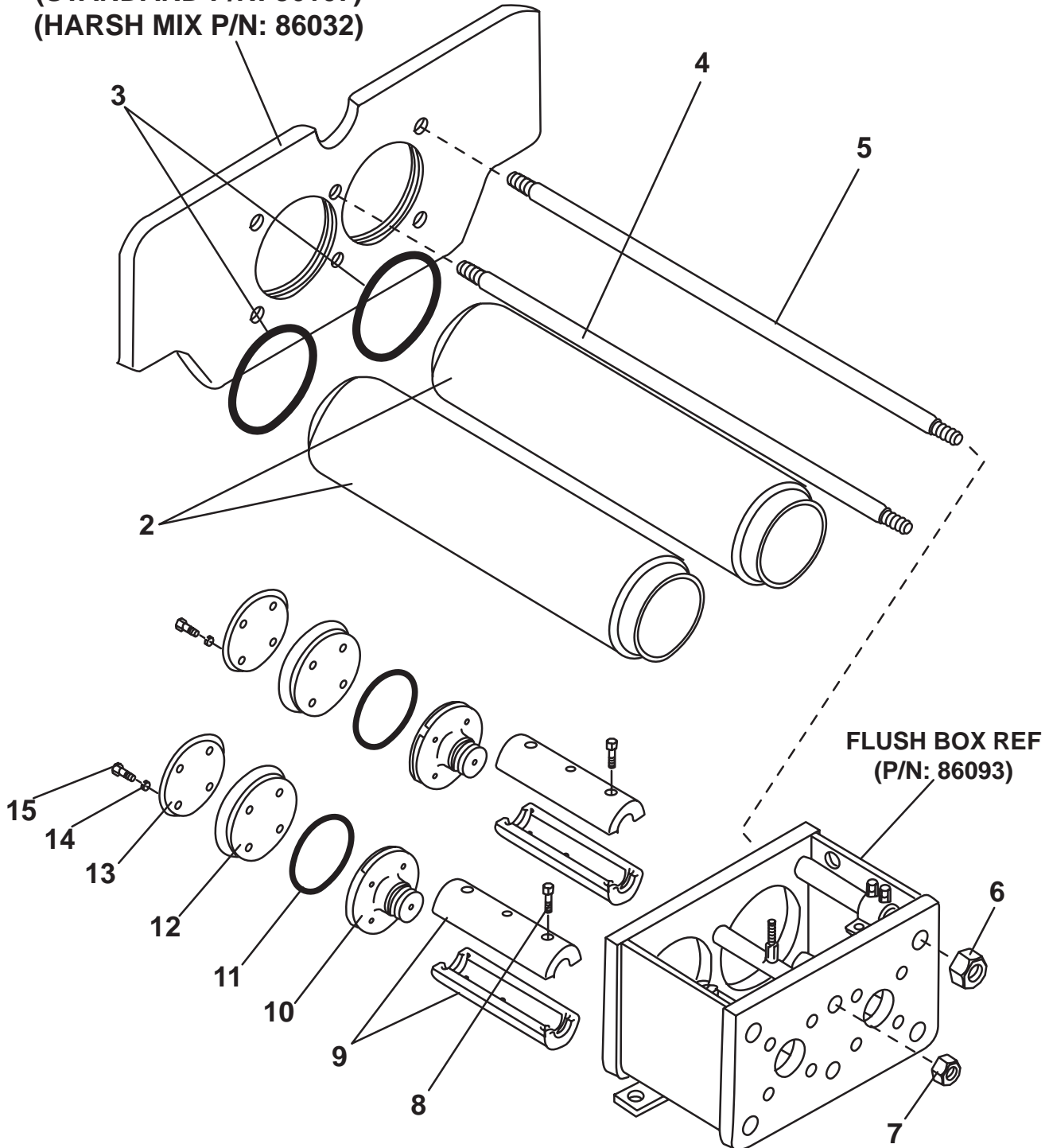





# MATERIAL CYLINDER ASSEMBLY

**B50**  
**PARTS**  
GROUP 60  
FIGURE 07  
PAGE 02

ITEM NO.	REED'S PART NO.	DESCRIPTION					QTY
		1	2	3	4	5	
-1	86309	Assembly, Material Cylinder (See Group 60, Figure 01 and Figure 02 for NHA)					Ref
2	86148	• Cylinder, Material					2
3	86149	• O-Ring, Material Cylinder					2
4	86047	• Rod, Tie					2
5	86046	• Rod, Tie					4
6		• Nut, Hex (attaching parts)					4
7		• Nut, Hex (attaching parts)					2
8		• Screw, Cap					4
9	86101	• Coupling, Piston					2
10	77194	• Adapter, 6 Inch Piston					2
11	77120	• Ring, 6 Inch Wear					2
12	70048	• Cup, 6 Inch Piston					2
13	70057	• Plate, 6 Inch Piston					2
14		• Washer, Star (attaching parts)					8
15		• Bolt, Hex (attaching parts)					8

DASH (-) ITEM NOT ILLUSTRATED

REVISION:

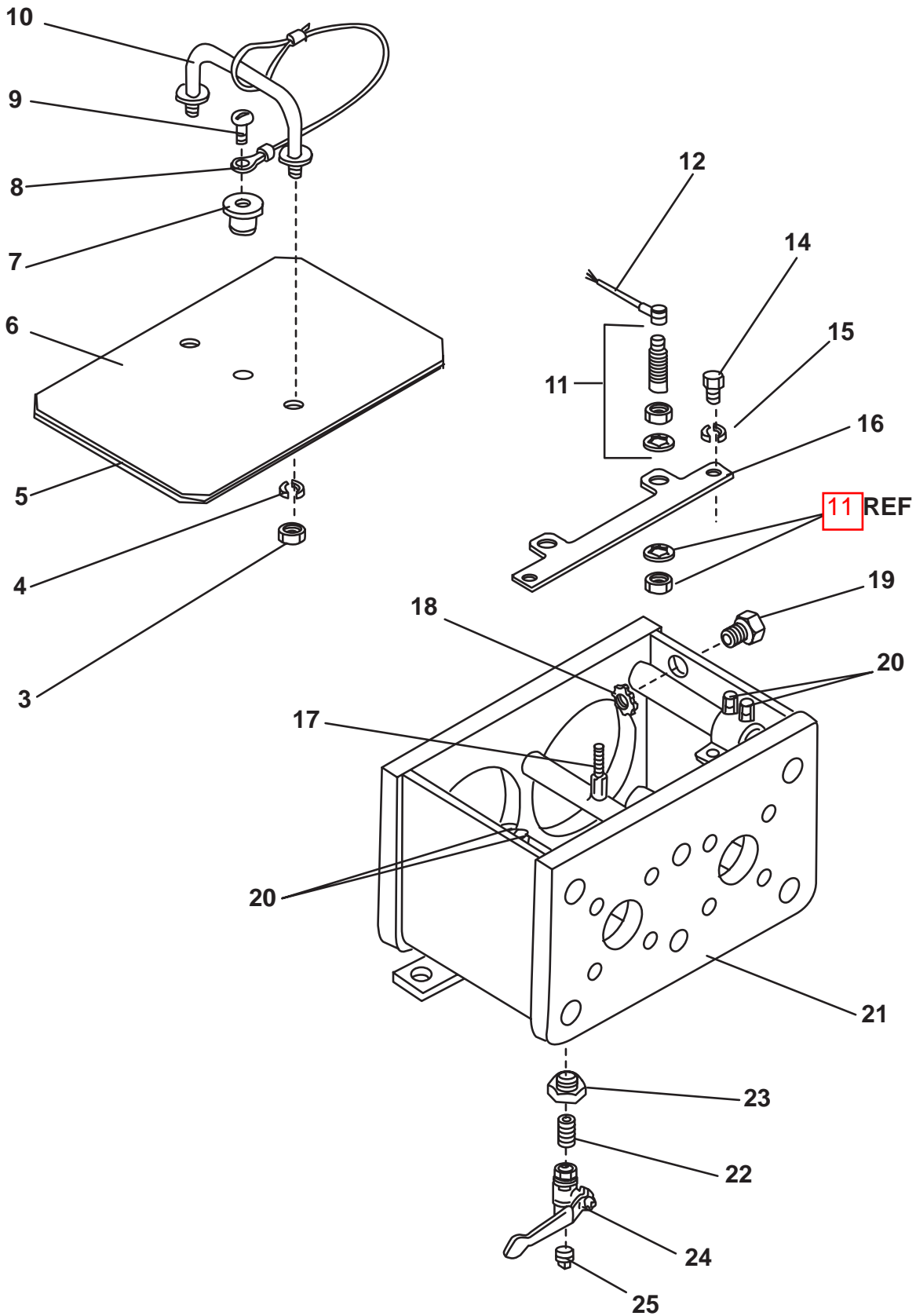



# FLUSH BOX ASSEMBLY

**B50**  
**PARTS**  
GROUP 60  
FIGURE 08  
PAGE 02

ITEM NO.	REED'S PART NO.	DESCRIPTION	QTY
		1 2 3 4 5	
-1	60-08	Assembly, Flushbox (See Group 60, Figure 01 and Figure 02 for NHA)	Ref
-2	86106	• Assembly, Flush Box Cover	1
3		• • Nut, Hex	2
4		• • Washer, Lock	2
5	13257	• • Weatherstrip, Rubber	A/R
6	86010	• • Weldment, Flush Box Cover	1
7	86105	• • Knob	1
8	800418	• • Lanyard	1
9		• • Screw, Round Head	1
10	79056	• • Handle, Splash Guard	1
11	77998	• Sensor, Proximity Switch	2
12	77990	• Cable, Proximity Switch	2
-13	86307	• Assembly, 6 Inch Flush Box Group	1
14		• • Bolt, Hex	2
15		• • Washer, Lock	2
16	86006	• • Bracket, Proximity Switch	1
17	86665	• • Stud	1
18	10528	• • Nut	1
19	73783	• • Conduit, Fitting	1
20		• • Bolt, Hex	4
21	86093	• • Weldment, Flush Box	1
22	10224	• Bushing, Hex	1
23	10355	• Nipple	1
24	56413	• Valve, Ball	1
25	74944	• Plug	1

DASH (-) ITEM NOT ILLUSTRATED

REVISION:

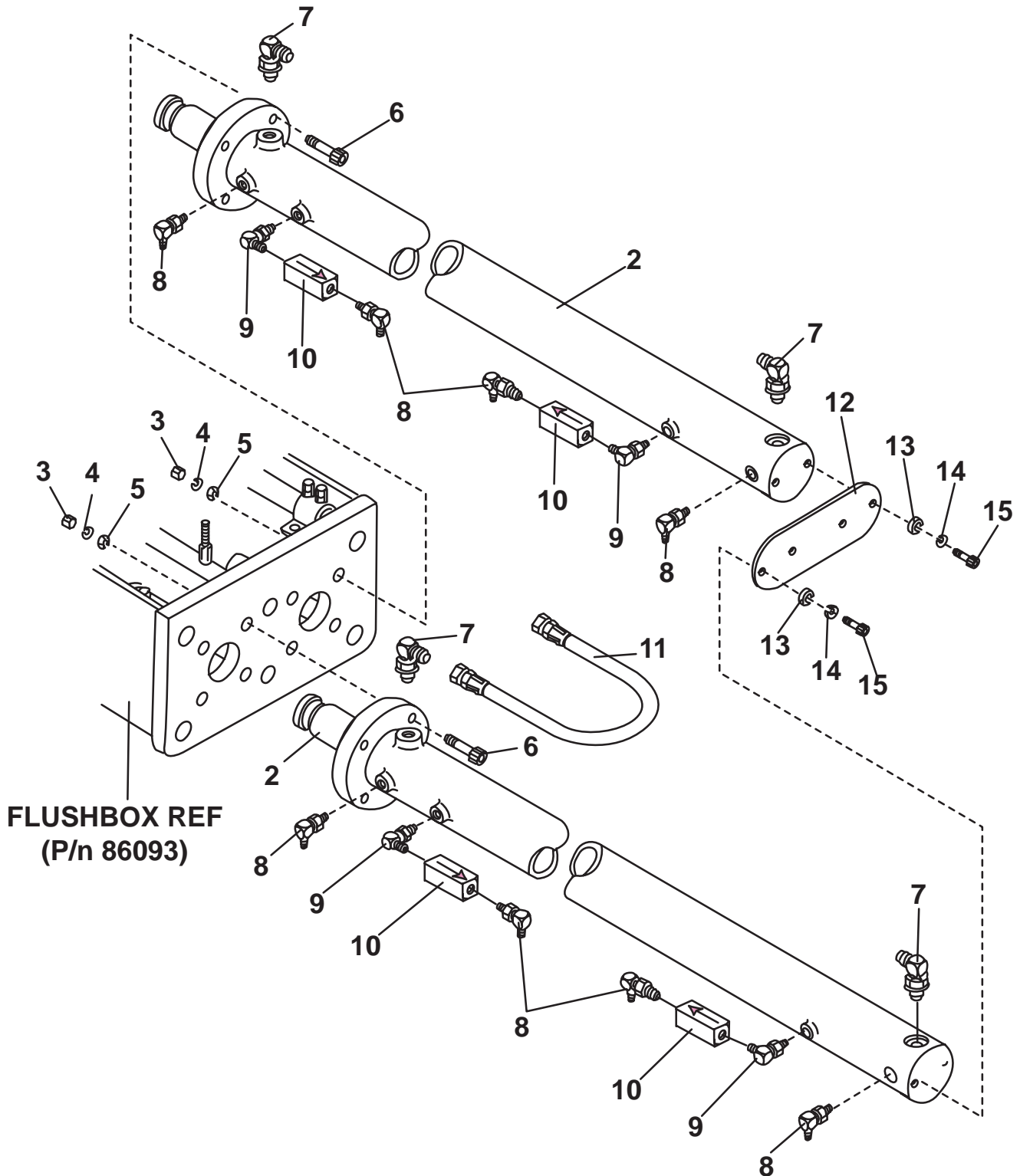



# HYDRAULIC DRIVE CYLINDER ASSEMBLY

**B50**  
**PARTS**  
GROUP 60  
FIGURE 09  
PAGE 02

ITEM NO.	REED'S PART NO.	DESCRIPTION					QTY
		1	2	3	4	5	
-1	86304	Assembly, Hydraulic Drive Cylinder (See Group 60, Figure 01 and Figure 02 for NHA)					Ref
2	86223	• Assembly, Drive Cylinder (See Group 60, Figure 10 for DET)					1
3		• Nut, Hex (attaching parts)					8
4		• Washer, Lock (attaching parts)					8
5	73396	• Washer, Thread (attaching parts)					8
6		• Bolt (attaching parts)					8
7		• Fitting, 90					4
8		• Fitting, 90					8
9		• Fitting, 90					4
10	78961	• Valve, Check					4
11	85427	• Assembly, Tube					1
12	86544	• Plate, End					1
13		• Washer, Flat (attaching parts)					4
14		• Washer, Lock (attaching parts)					4
15		• Bolt, Hex (attaching parts)					4

DASH (-) ITEM NOT ILLUSTRATED

REVISION:

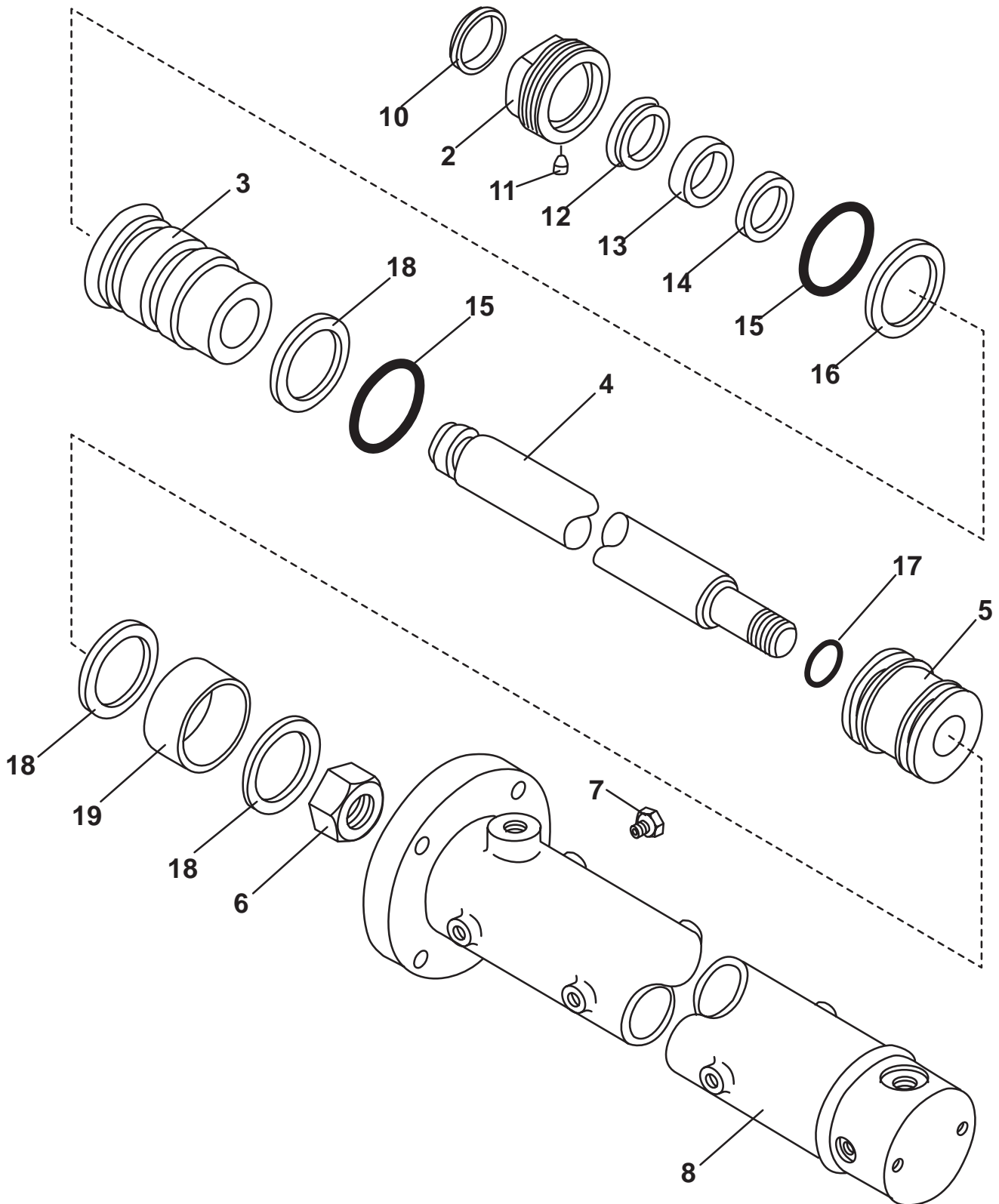



# DRIVE CYLINDER ASSEMBLY

**B50**  
**PARTS**  
GROUP 60  
FIGURE 10  
PAGE 02

ITEM NO.	REED'S PART NO.	DESCRIPTION					QTY
		1	2	3	4	5	
-1	86223	Assembly, Drive Cylinder (See Group 60, Figure 09 for NHA)					Ref
2		• Ring, Threaded					1
3		• Gland, Head					1
4		• Rod, Cylinder					1
5		• Piston					1
6		• Nut, Piston					4
7		• Plug					4
8		• Weldment, Cylinder Case					1
-9	86223-SK	• Kit, Seal					1
10		• • Wiper, Rod					1
11		• • Plug, Nylon					1
12		• • Ring, Back Up					1
13		• • U-Cup					1
14		• • Seal, Buffer					1
15		• • O-Ring					2
16		• • Ring, Back Up					2
17		• • O-Ring					1
18		• • Seal, Piston					2
19		• • Ring, Wear					1

DASH (-) ITEM NOT ILLUSTRATED

REVISION:



**TRAILER MOUNTED PUMP MODEL *B50*  
GROUP 60 PUMPING TRAIN INSTALLATION**

***B50*  
PARTS  
GROUP 60  
FIGURE 11  
PAGE 01**

THIS PAGE INTENTIONALLY LEFT BLANK





## TRAILER MOUNTED PUMP MODEL *B50* GROUP 70 FRAME INSTALLATION

*B50*  
PARTS  
GROUP 70  
FIGURE 00  
PAGE 01

**REED** TRAILER MOUNTED CONCRETE PUMP MODEL *B50* ILLUSTRATED PARTS MANUAL GROUP 70 FRAME INSTALLATION CONTAINS THE FOLLOWING FIGURES:

<b>FIGURE</b>	<b>00</b>	TABLE OF CONTENTS
<b>FIGURE</b>	<b>01</b>	FRAME INSTALLATION
<b>FIGURE</b>	<b>02</b>	HUB AND BRAKE ASSEMBLY
<b>FIGURE</b>	<b>03</b>	NON-OPERATOR SIDE ELECTRIC BRAKE ASSEMBLY
<b>FIGURE</b>	<b>04</b>	OPERATOR SIDE ELECTRIC BRAKE ASSEMBLY



REVISION:

## FRAME INSTALLATION

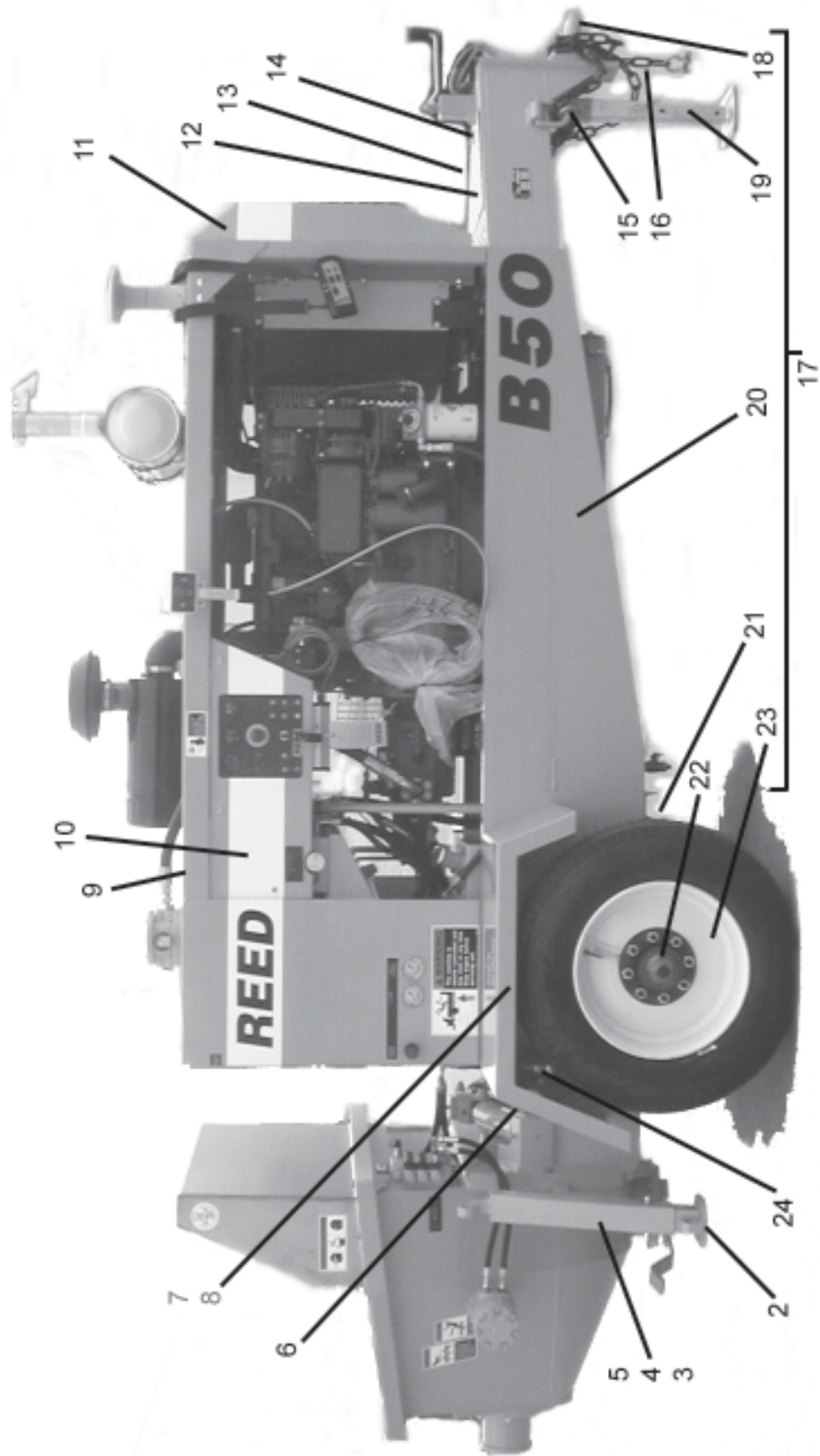



# FRAME INSTALLATION

**B50**  
**PARTS**  
GROUP 70  
FIGURE 01  
PAGE 02

ITEM NO.	REED'S PART NO.	DESCRIPTION					QTY
		1	2	3	4	5	
-1	70-01	Installation, Frame (See Group 10, Figure 01, 02, 03, and 04 for NHA)					Ref
2	86553	• Weldment, Outrigger Inner					2
3	86557	• Weldment, Outrigger Outer Tube					2
4	85595	• Pin, Outrigger Safety					2
5	800418	• Lanyard, Q/R Pin					2
6	72948	• Light, Tail					2
7	86959	• Weldment, Right Fender					1
8	86960	• Weldment, Left Fender					1
9	87129	• Assembly, Top Panel					1
10	85391	• Cover, Control Box					1
11	87141	• Cover, Front					1
12	85338	• Cover, Tool Box					1
13	86533	• Assembly, Trailer Wiring Harness (See Schematic Section, Page 12 for REF)					1
14	77705	• Kit, Break Away					1
15	87085	• Connector, Chain					4
16	86730	• Chain, 3/8 Proof Coil-5 FT					2
17	87174	• Assembly, Frame					1
18	87037	• • Drawbar					1
19	85527	• • Weldment, Jack					1
20	87135	• • Weldment, Frame					1
21	86924	• • Axle-9000 Lbs					1
22	70-02	• • Assembly, Hub and Brake (See Group 70, Figure 02 for DET)					1
23	86923	• • Assembly, Wheel and Tire					2
24	72949	• Grommet, Trailer					3

DASH (-) ITEM NOT ILLUSTRATED

REVISION:

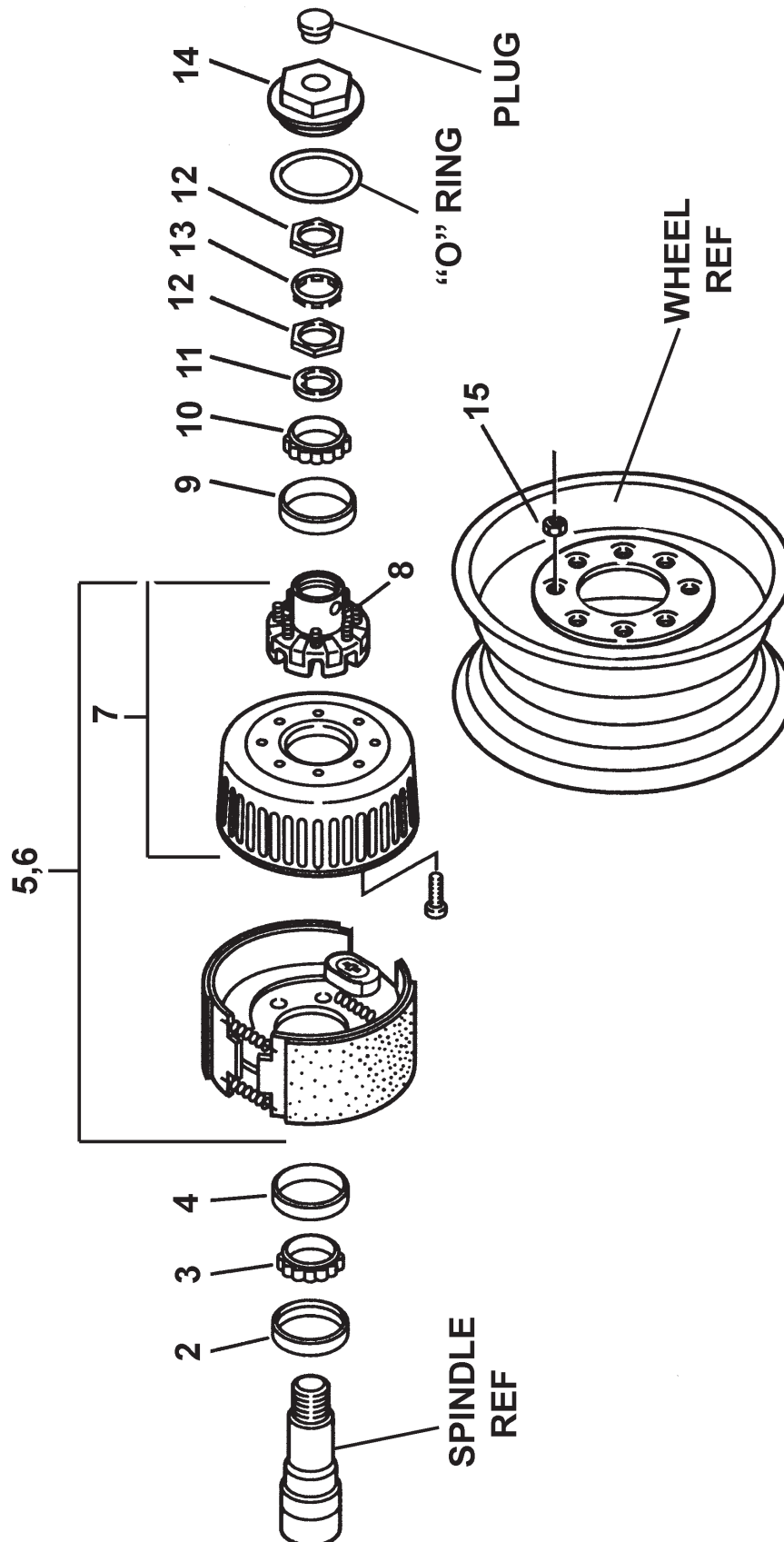



# HUB AND BRAKE ASSEMBLY

**B50**  
**PARTS**  
GROUP 70  
FIGURE 02  
PAGE 02

ITEM NO.	REED'S PART NO.	DESCRIPTION	QTY
		1 2 3 4 5	
-1	70-02	Assembly, Hub and Brake (Left And Right Side) (See Group 70, Figure 01 for NHA)	Ref
2	-	• Seal, Double Lip Grease	2
3	-	• Bearing, Inner	2
4	-	• Race, Inner Bearing	2
5	LH	• Assembly, Non-Operator Side Electric Brake (Set) (See Group 70, Figure 03 for DET)	1
6	RH	• Assembly, Operator Side Electric Brake (Set) (See Group 70, Figure 04 for DET)	1
7	-	• Assembly, Drum and Hub	2
8	-	• Stud, Wheel	16
9	-	• Race, Outer Bearing	2
10	-	• Bearing, Outer	2
11	-	• Washer, Spindle	2
12	-	• Nut, Spindle	4
13	-	• Washer, Tang	2
14	-	• Cap, Oil	2
15	-	• Nut, Wheel	16

DASH (-) ITEM NOT ILLUSTRATED

REVISION:

## NON OPERATOR SIDE ELECTRIC BRAKE ASSEMBLY

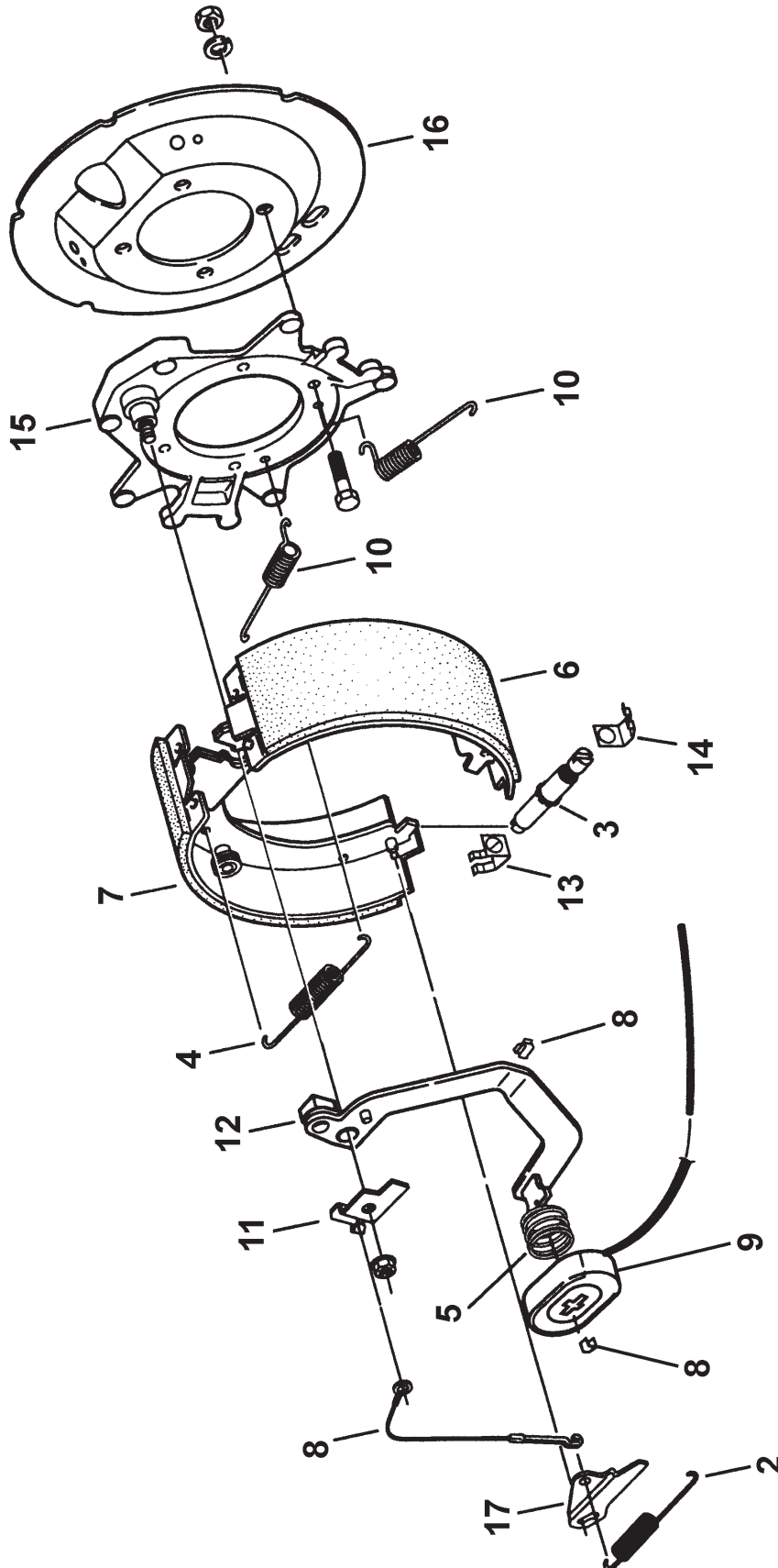

REVISION:



# NON OPERATOR SIDE ELECTRIC BRAKE ASSEMBLY

**B50**  
**PARTS**  
GROUP 70  
FIGURE 03  
PAGE 02

ITEM NO.	REED'S PART NO.	DESCRIPTION					QTY
		1	2	3	4	5	
-1	LH	Assembly, Non-Operator Side Electric Brake (See Group 70, Figure 02 for NHA)					Ref
2		• Spring, Adjuster Screw					1
3		• Sub-Assembly, Adjuster Screw					1
4		• Spring, Shoe Retractor					1
5		• Spring, Shoe Hold Down					1
6		• Shoe and Lining, Secondary					1
7		• Shoe and Lining, Primary					1
8		• Clip, Wire and Magnet					2
9		• Sub-Assembly, Magnet					1
10		• Spring, Centering					2
11		• Retainer, Arm/Shoe					1
12		• Lever, Non-Operator Side					1
13		• Clip, Adjuster (Barrel End)					1
14		• Clip, Adjuster (Thread End)					1
15		• Assembly, Backing Plate					1
16		• Shield, Dust					1
17		• Lever, Adjuster					1
18		• Cable, Adjuster					1

DASH (-) ITEM NOT ILLUSTRATED

REVISION:

## OPERATOR SIDE ELECTRIC BRAKE ASSEMBLY

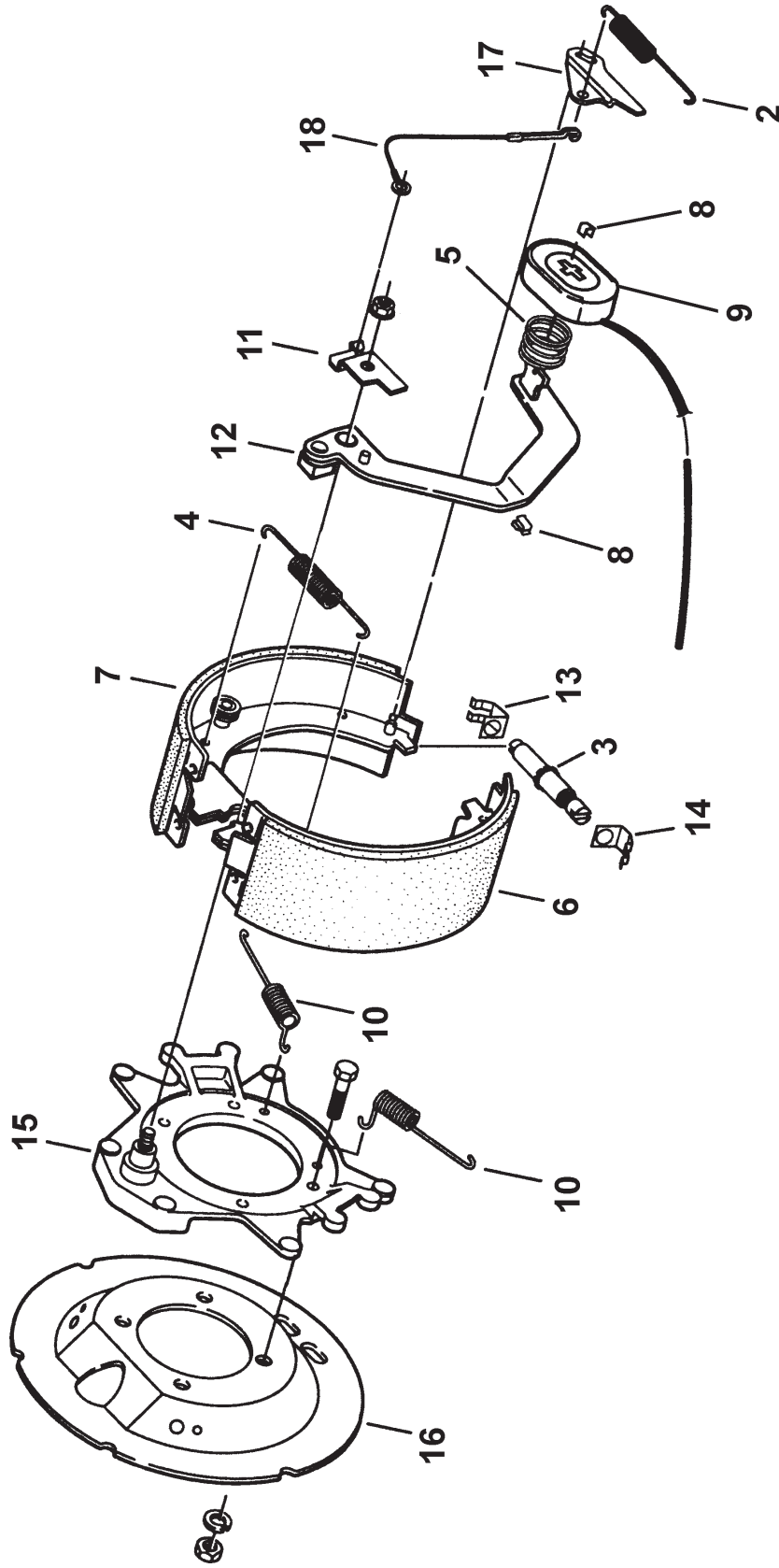

REVISION:





# OPERATOR SIDE ELECTRIC BRAKE ASSEMBLY

**B50**  
**PARTS**  
GROUP 70  
FIGURE 04  
PAGE 02

ITEM NO.	REED'S PART NO.	DESCRIPTION					QTY
		1	2	3	4	5	
-1	RH	Assembly, Operator Side Electric Brake (See Group 70, Figure 02 for NHA)					Ref
2		• Spring, Adjuster Screw					1
3		• Sub-Assembly, Adjuster Screw					1
4		• Spring, Shoe Retractor					1
5		• Spring, Shoe Hold Down					1
6		• Shoe and Lining, Secondary					1
7		• Shoe and Lining, Primary					1
8		• Clip, Wire and Magnet					2
9		• Sub-Assembly, Magnet					1
10		• Spring, Centering					2
11		• Retainer, Arm/Shoe					1
12		• Lever, Operator Side					1
13		• Clip, Adjuster (Barrel End)					1
14		• Clip, Adjuster (Thread End)					1
15		• Assembly, Backing Plate					1
16		• Shield, Dust					1
17		• Lever, Adjuster					1
18		• Cable, Adjuster					1

DASH (-) ITEM NOT ILLUSTRATED

REVISION:



**TRAILER MOUNTED PUMP MODEL  
B50 ILLUSTRATED PARTS MANUAL**

**B50  
PARTS  
GROUP 70  
FIGURE 05  
PAGE 01**

THIS PAGE INTENTIONALLY LEFT BLANK



**REED** TRAILER MOUNTED CONCRETE PUMP MODEL **B50** ILLUSTRATED PARTS MANUAL GROUP 80 OPTIONAL INSTALLATION CONTAINS THE FOLLOWING FIGURES:

<b>FIGURE</b>	<b>00</b>	TABLE OF CONTENTS
<b>FIGURE</b>	<b>01</b>	OPTIONAL INSTALLATION
<b>FIGURE</b>	<b>02</b>	LUBE SYSTEM ASSEMBLY
<b>FIGURE</b>	<b>03</b>	12 VOLT LUBE PUMP ASSEMBLY
<b>FIGURE</b>	<b>04</b>	HOPPER VIBRATOR ASSEMBLY
<b>FIGURE</b>	<b>05</b>	THROTTLE SOLENOID ASSEMBLY
<b>FIGURE</b>	<b>06</b>	ACCUMULATOR CHARGE KIT
<b>FIGURE</b>	<b>07</b>	OPTIONAL TOOL KIT ASSEMBLY
<b>FIGURE</b>	<b>08</b>	ACTUATOR BRAKES ASSEMBLY
<b>FIGURE</b>	<b>09</b>	WATER PUMP INSTALLATION
<b>FIGURE</b>	<b>10</b>	WATER PUMP CONTROL VALVE ASSEMBLY
<b>FIGURE</b>	<b>11</b>	WATER PUMP MOTOR ASSEMBLY
<b>FIGURE</b>	<b>12</b>	WATER PUMP ASSEMBLY
<b>FIGURE</b>	<b>13</b>	NON-OPERATOR SIDE HYDRAULIC BRAKE ASSM.
<b>FIGURE</b>	<b>14</b>	OPERATOR SIDE HYDRAULIC BRAKE ASSEMBLY
<b>FIGURE</b>	<b>15</b>	HYDRAULIC OUTRIGGER CYLINDER ASSEMBLY
<b>FIGURE</b>	<b>16</b>	1 SPOOL CONTROL VALVE ASSEMBLY
<b>FIGURE</b>	<b>17</b>	1 SPOOL CONTROL VALVE SUBASSEMBLY
<b>FIGURE</b>	<b>18</b>	2 SPOOL CONTROL VALVE ASSEMBLY
<b>FIGURE</b>	<b>19</b>	2 SPOOL CONTROL VALVE SUBASSEMBLY
<b>FIGURE</b>	<b>20</b>	SIDE DOOR ASSEMBLY
<b>FIGURE</b>	<b>21</b>	50 FEET STROKE COUNTER REMOTE CONTROLLER
<b>FIGURE</b>	<b>22</b>	100 FEET STROKE COUNTER REMOTE CONTROLLER

# REED

## OPTIONAL INSTALLATION

**B50**  
**PARTS**  
GROUP 80  
FIGURE 01  
PAGE 01

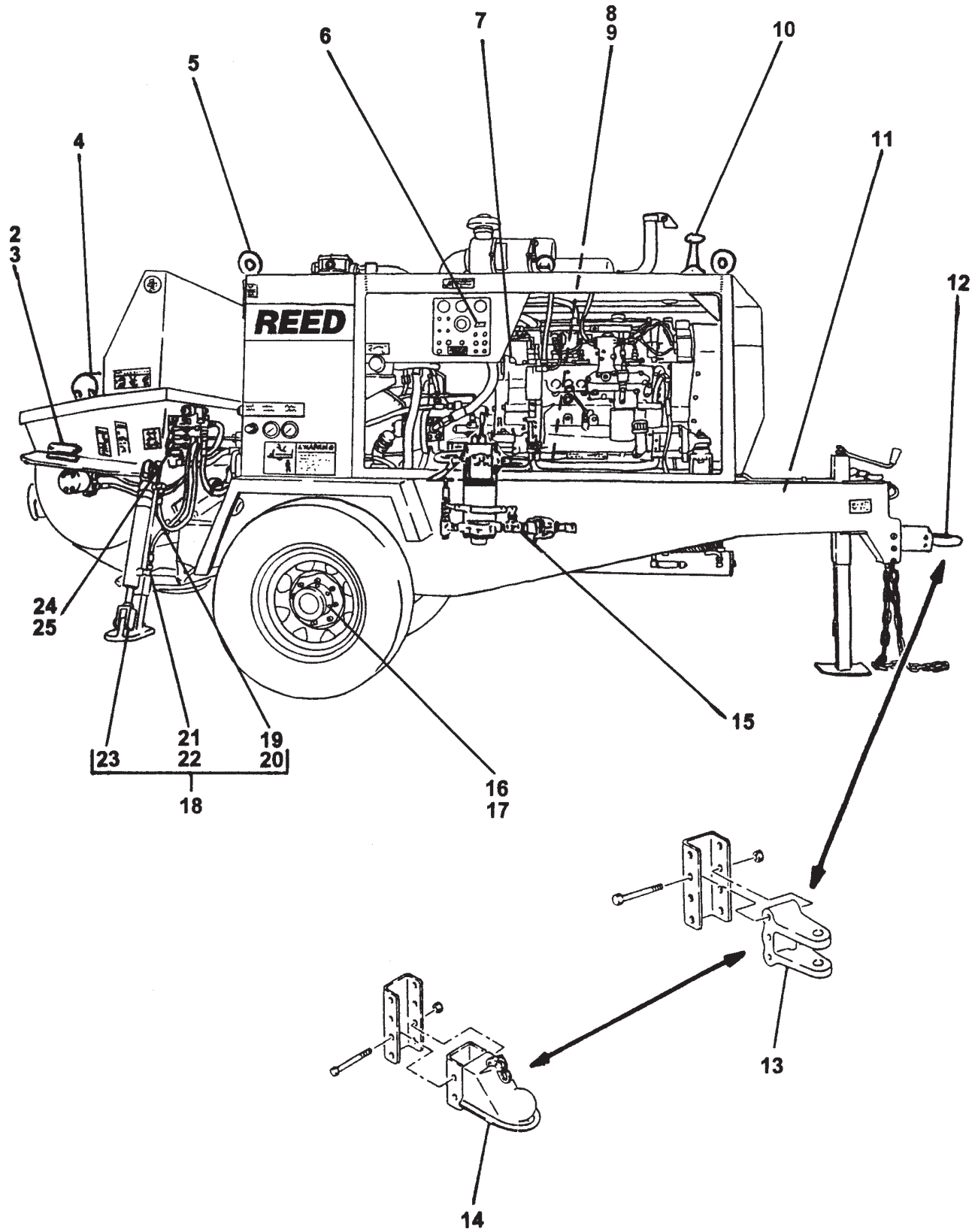

REVISION:



## OPTIONAL INSTALLATION

**B50**  
**PARTS**  
GROUP 80  
FIGURE 01  
PAGE 02

ITEM NO.	REED'S PART NO.	DESCRIPTION					QTY
		1	2	3	4	5	
-1	80-01	Installation, Optional (See Group 10, Figure 01 02, 03 and 04 for NHA)					Ref
2	80-02	• Assembly, Lube System (See Group 80, Figure 02 for DET)					1
3	78736	• Assembly, Lube Pump (See Group 80, Figure 03 for DET)					1
4	71429	• Assembly, Hopper Vibration (See Group 80, Figure 04 for DET)					1
5	85810	• Assembly, Optional Lifting					1
6	85774	• Assembly, Stroke Counter					1
7	77012	• Assembly, Throttle Solenoid (See Group 80, Figure 05 for DET)					1
8	71460	• Kit, Accumulator Charge (See Group 80, Figure 06 for DET)					1
9	30-11	• Kit, Bladder Repair (See Group 30, Figure 11 for REF)					1
10	85818	• Assembly, Radio Remote Control (See Group 50, Figure 05 for REF)					1
11	79020	• Assembly, Optional Tool Kit (See Group 80, Figure 07 for DET)					1
12	75413	• Assembly, Actuator Brake (See Group 80, Figure 08 for DET)					1
13	71050	• Assembly, Adjustable 1 Inch Clevis					1
14	71099	• Assembly, Adjustable Ball Coupler 2-5/16"					1
15	86400	• Installation, Water Pump (See Group 80, Figure 09 for DET)					1
16	80-13	• Assembly, Non-Operator Side Hydraulic Brake (See Group 80, Figure 13 for DET)					1
17	80-14	• Assembly, Operator Side Hydraulic Brake (See Group 80, Figure 14 for DET)					1
18	85677	• Assembly, Hydraulic Outrigger					1
19	85685	• • Assembly, Tube					2
20	85686	• • Assembly, Tube					2
21	85659-010	• • Assembly, Hose (See Schematic Section, Figure 05 for REF)					4
22		• • Elbow, 90					4
23	85640	• • Assembly, Hydraulic Outrigger Cylinder (See Group 80, Figure 15 for DET)					2
24	80-16	• Assembly, 1 Spool Valve (See Group 80, Figure 16 for DET)					1
25	80-18	• Assembly, 2 Spool Valve (See Group 80, Figure 18 for DET)					1
-26	85943	• Assembly, Side Door (See Group 80, Figure 20 for DET)					1
-27	85960	• Assembly, 50 Feet Remote Control Stroke Counter (See Group 80, Figure 21 for DET)					1
-28	85960A	• Assembly, 100 Feet Remote Control Stroke Counter (See Group 80, Figure 22 for DET)					1

DASH (-) ITEM NOT ILLUSTRATED

REVISION:

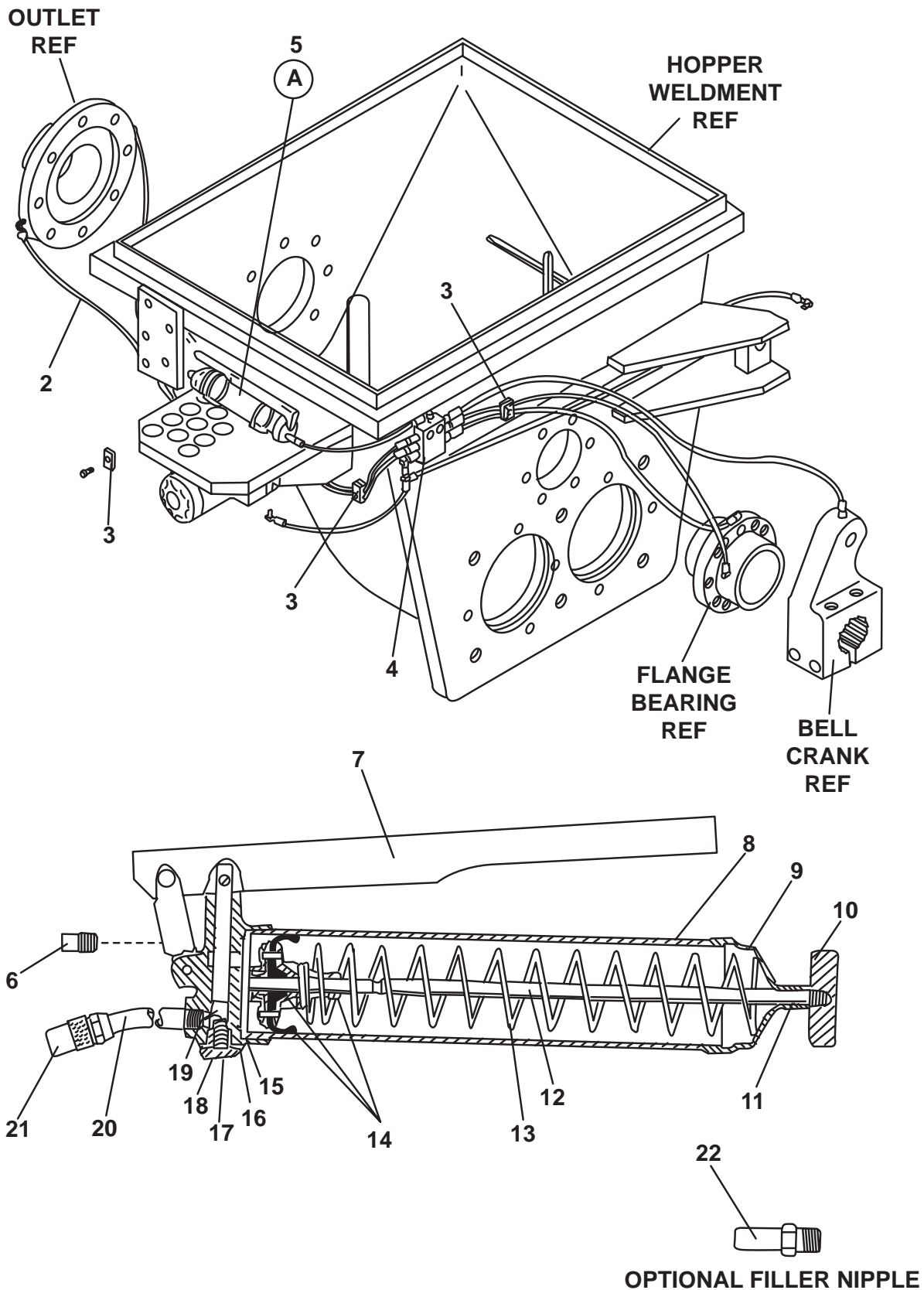



## LUBE SYSTEM ASSEMBLY

**B50**  
**PARTS**  
GROUP 80  
FIGURE 02  
PAGE 02

ITEM NO.	REED'S PART NO.	DESCRIPTION					QTY
		1	2	3	4	5	
-1	80-02	Assembly, Lube System (See Group 80, Figure 01 for NHA)					Ref
2		• Assembly, Lube Hose					A/R
3	75436	• Clamp, Pipe					3
4	72355	• Block, 6 Station Lube System					1
5	78532	• Gun, Grease					1
6		• • Plug					1
7		• • Handle, Pumping					1
8		• • Tube, Container					1
9		• • Cup, Tube					1
10		• • Handle, Follower					1
11		• • Spacer					1
12		• • Rod, Follower					1
13		• • Spring					1
14		• • Sub-Assembly, Follower					1
15		• • Packing, Container					1
16		• • Gasket					1
17		• • Housing, Spring					1
18		• • Spring					1
19		• • Ball, Check					1
20		• • Extension, Nozzle					1
21		• • Coupler, Hydraulic					1
22		• • Nipple, Filler (Optional Item)					1

DASH (-) ITEM NOT ILLUSTRATED

REVISION:



# LUBE PUMP ASSEMBLY

**B50**  
**PARTS**  
GROUP 80  
FIGURE 03  
PAGE 01

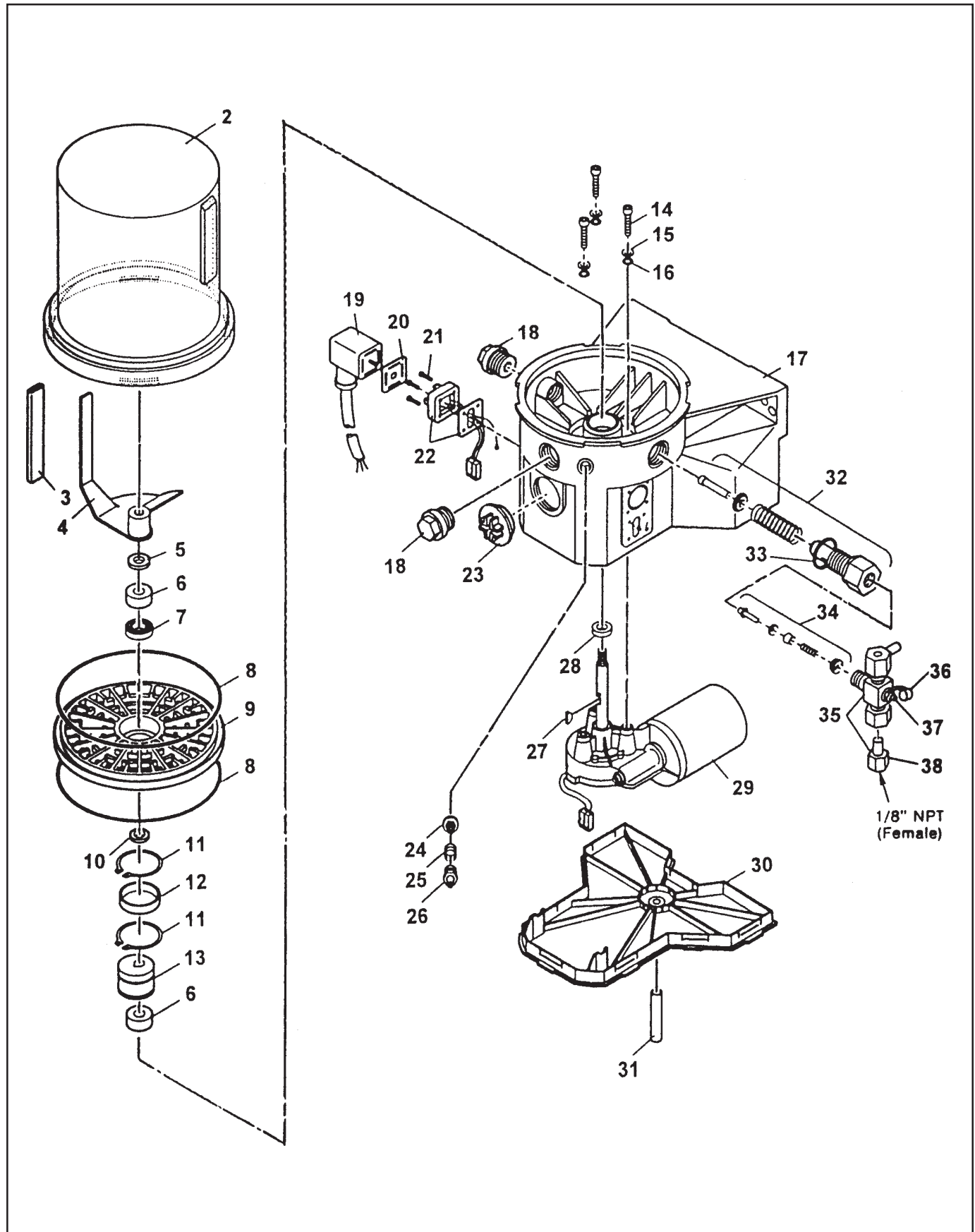

REVISION:





# LUBE PUMP ASSEMBLY

**B50**  
**PARTS**  
GROUP 80  
FIGURE 03  
PAGE 02

ITEM NO.	REED'S PART NO.	DESCRIPTION					QTY
		1	2	3	4	5	
-1	78736	Assembly, Lube Pump (See Group 80, Figure 01 for NHA)					Ref
2		• Reservoir					1
3		• House					1
4		• Paddle, Stirring					1
5		• Washer					1
6		• Ring, Bearing					2
7		• Bearing					1
8		• O-Ring					2
9		• Plate, Intermediate					1
10		• Shim					1
11		• Ring, Snap					2
12		• Ring, Inner					1
13		• Cam, Eccentric					1
14		• Screw					3
15		• Washer					3
16		• O-Ring					3
17		• Housing, Pump					1
18		• Plug, Closure					2
19		• Socket with Cord					1
20		• Packing, Flat					1
21		• Screw					4
22		• Plug					1
23		• Plug, Sealing					1
24		• Insert, Filter					1
25		• Spring					1
26		• Fitting, Grease					1
27		• Key, Woodruff					1
28		• Seal, Radial					1
29		• Motor, 12 VDC					1
30		• Cover, Housing					1
31		• Hose					1
32		• Element, Pump					1
33		• Gasket					1
34		• Valve, Check					1
35		• Assembly, Pressure Reliefs					1
36		• Cap, Grease					1
37		• Fitting, Grease					1
38		• Assembly, Adapter for Relief					1

DASH (-) ITEM NOT ILLUSTRATED

REVISION:

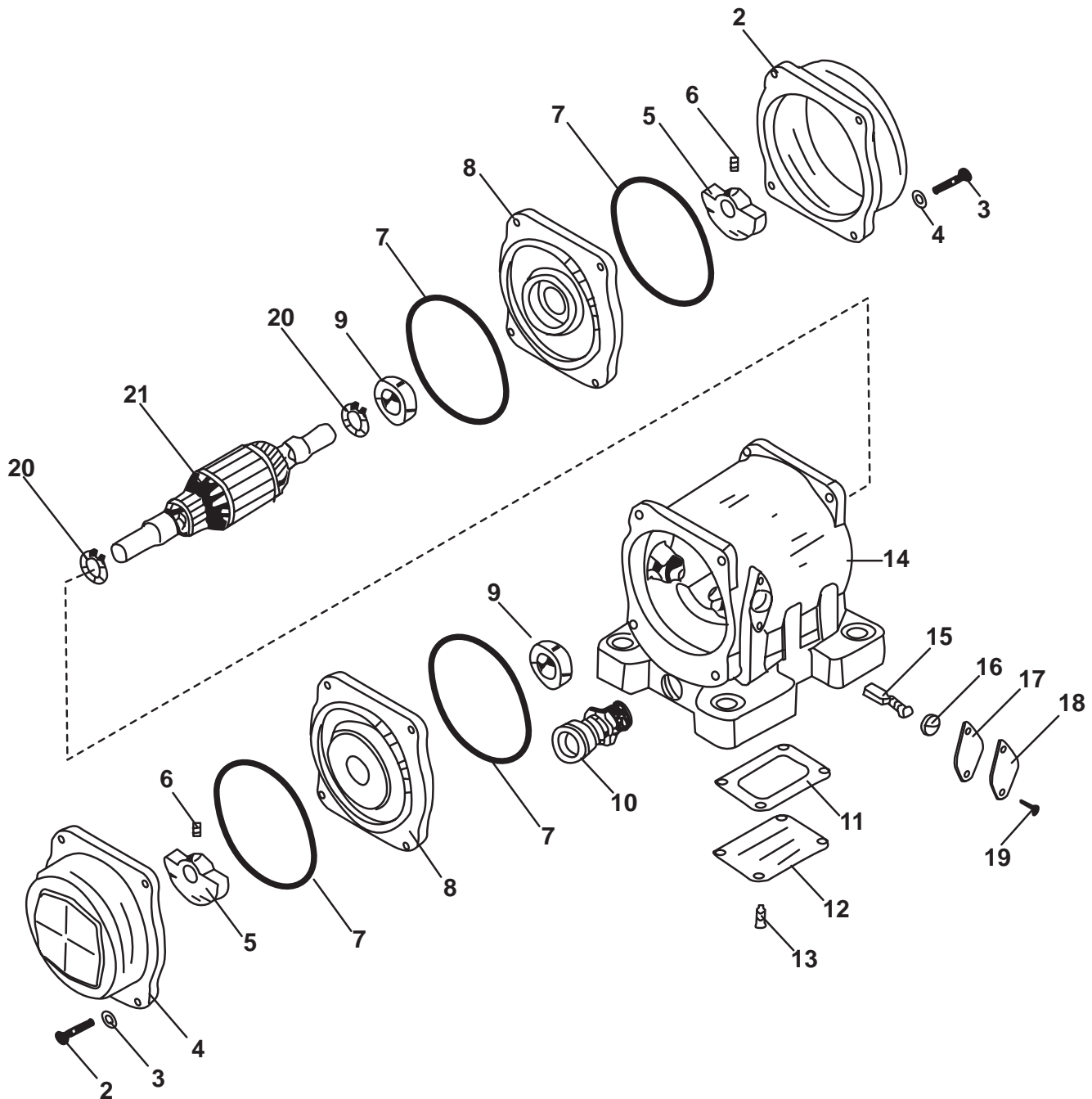



# HOPPER VIBRATOR ASSEMBLY

**B50**  
**PARTS**  
GROUP 80  
FIGURE 04  
PAGE 02

ITEM NO.	REED'S PART NO.	DESCRIPTION					QTY
		1	2	3	4	5	
-1	71429	Assembly, Hopper Vibrator (See Group 80, Figure 01 for NHA)					Ref
2		• Cap, End					2
3		• Bolt (attaching parts)					8
4		• Washer, Lock (attaching parts)					8
5		• Weight					2
6		• Screw, Set (attaching parts)					2
7		• O-Ring					4
8		• Bell, End					2
9		• Bearing					2
10		• Holder, Cord					1
11		• Gasket					1
12		• Cover, Box					1
13		• Screw, (attaching parts)					4
14		• Sub-Assembly, Housing					1
15		• Brush					1
16		• Cap, Brush					2
17		• Gasket					2
18		• Cover, Brush					2
19		• Screw (attaching parts)					4
20		• Ring, Snap					2
21		• Assembly, Armature					1

DASH (-) ITEM NOT ILLUSTRATED

REVISION:

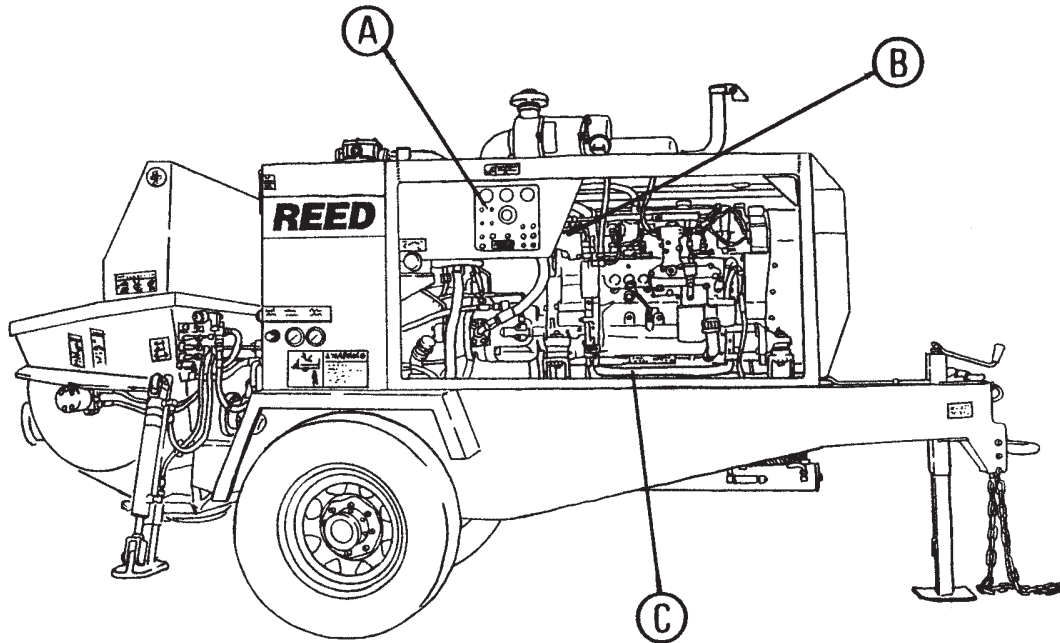

CONTROL BOX REF  
(P/N:85358)

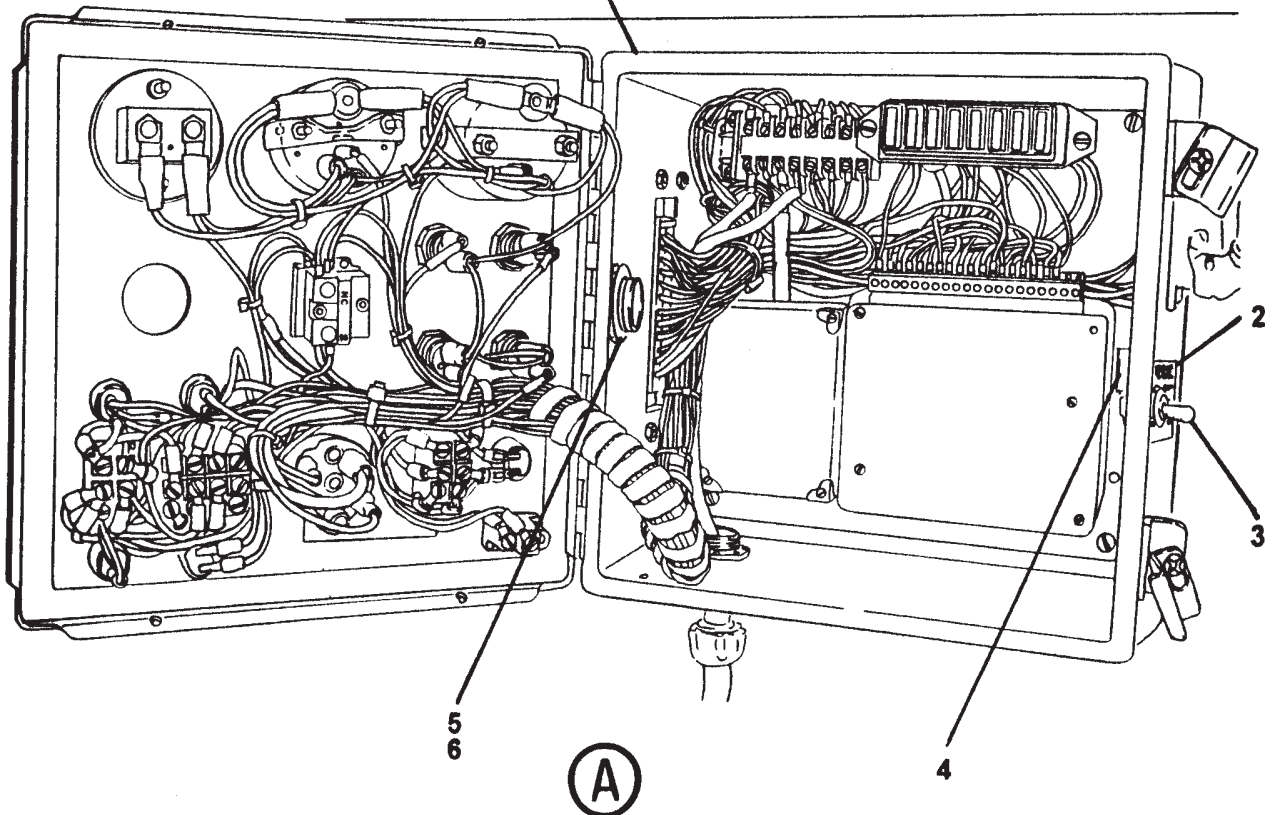



## THROTTLE SOLENOID ASSEMBLY

**B50**  
**PARTS**  
GROUP 80  
FIGURE 05  
PAGE 02

ITEM NO.	REED'S PART NO.	DESCRIPTION	QTY
		1 2 3 4 5	
-1	86134	Assembly, Throttle Solenoid (See Group 80, Figure 01 for NHA)	Ref
2	86131	• Case, Charge Kit	1
3	72965	• Switch, ON/OFF/ON Toggle	1
4	71955	• Relay, 12V	1
5	10523	• Relief, Strain	1
6	10528	• Nut, Bonding Type Lock	1
7	77012	• Solenoid, Throttle	1
8		• • Solenoid	1
9	71955	• • Relay, 12V	1
10	72294	• • Bolt, Throttle Control	1
11	78202	• • Coupler	1
12	85615	• Cable, 7 Feet 14AWG-2C	A/R
13	85617	• Cable, 6 Feet 14AWG-4C	A/R
14	801359	• Holder, Fuse with Cover	1
15	801360	• Fuse, 50AMP	1
16		• Bolt, Hex	1
17		• Washer, Flat	2
18		• Nut, Lock	1

DASH (-) ITEM NOT ILLUSTRATED

REVISION:

# REED

## THROTTLE SOLENOID ASSEMBLY

B50  
PARTS  
GROUP 80  
FIGURE 05  
PAGE 03

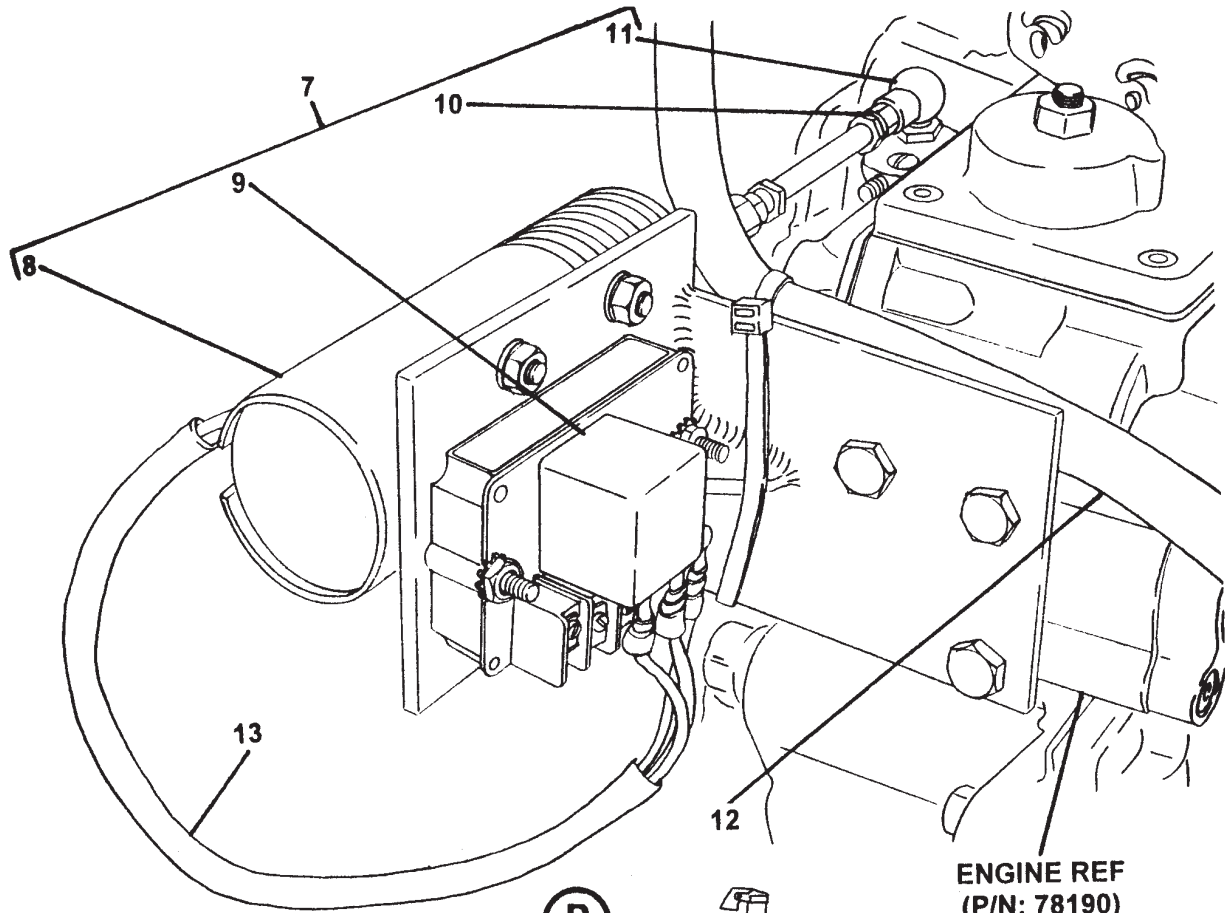

(B)

ENGINE REF  
(P/N: 78190)

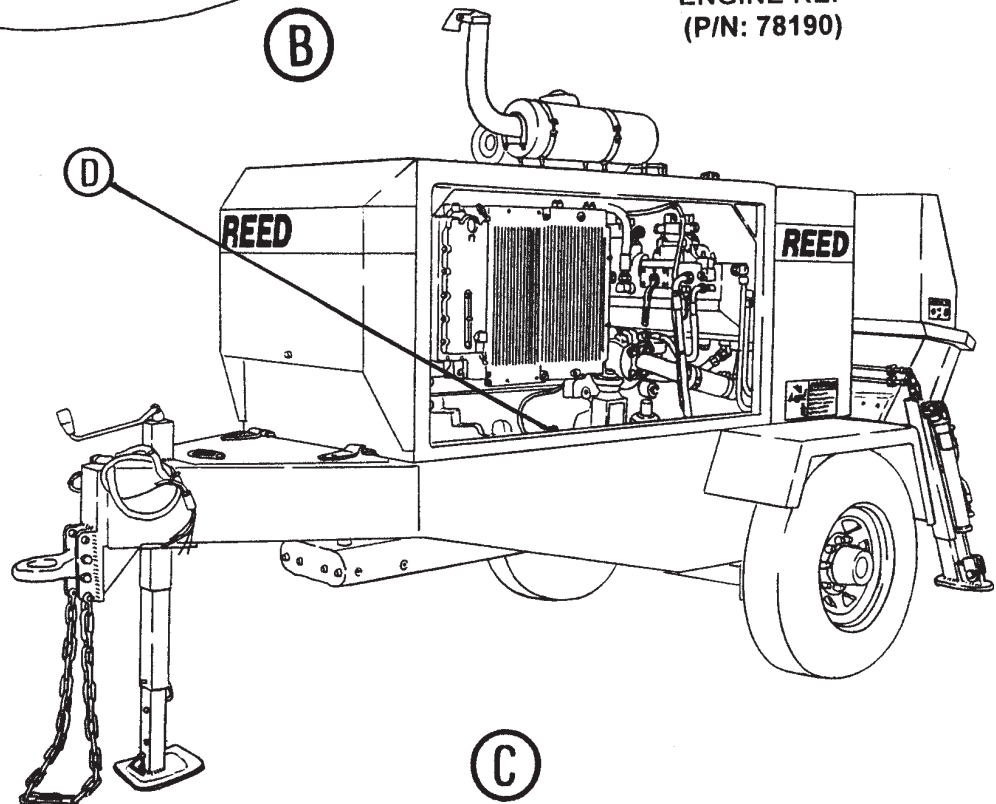

(C)

REVISION:



# THROTTLE SOLENOID ASSEMBLY

**B50**  
**PARTS**  
GROUP 80  
FIGURE 05  
PAGE 04

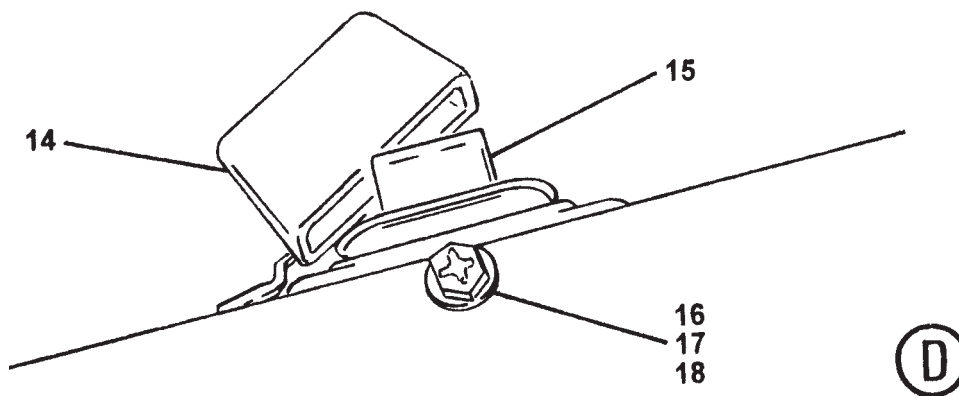

ITEM NO.	REED'S PART NO.	DESCRIPTION	QTY
		1 2 3 4 5	
-1	86134	Assembly, Throttle Solenoid (See Group 80, Figure 01 for NHA)	<b>Ref</b>
2	86131	• Case, Charge Kit	1
3	72965	• Switch, ON/OFF/ON Toggle	1
4	71955	• Relay, 12V	1
5	10523	• Relief, Strain	1
6	10528	• Nut, Bonding Type Lock	1
7	77012	• Solenoid, Throttle	1
8		• • Solenoid	1
9	71955	• • Relay, 12V	1
10	72294	• • Bolt, Throttle Control	1
11	78202	• • Coupler	1
12	85615	• Cable, 7 Feet 14AWG-2C	A/R
13	85617	• Cable, 6 Feet 14AWG-4C	A/R
14	801359	• Holder, Fuse with Cover	1
15	801360	• Fuse, 50AMP	1
16		• Bolt, Hex	1
17		• Washer, Flat	2
18		• Nut, Lock	1

DASH (-) ITEM NOT ILLUSTRATED

REVISION:

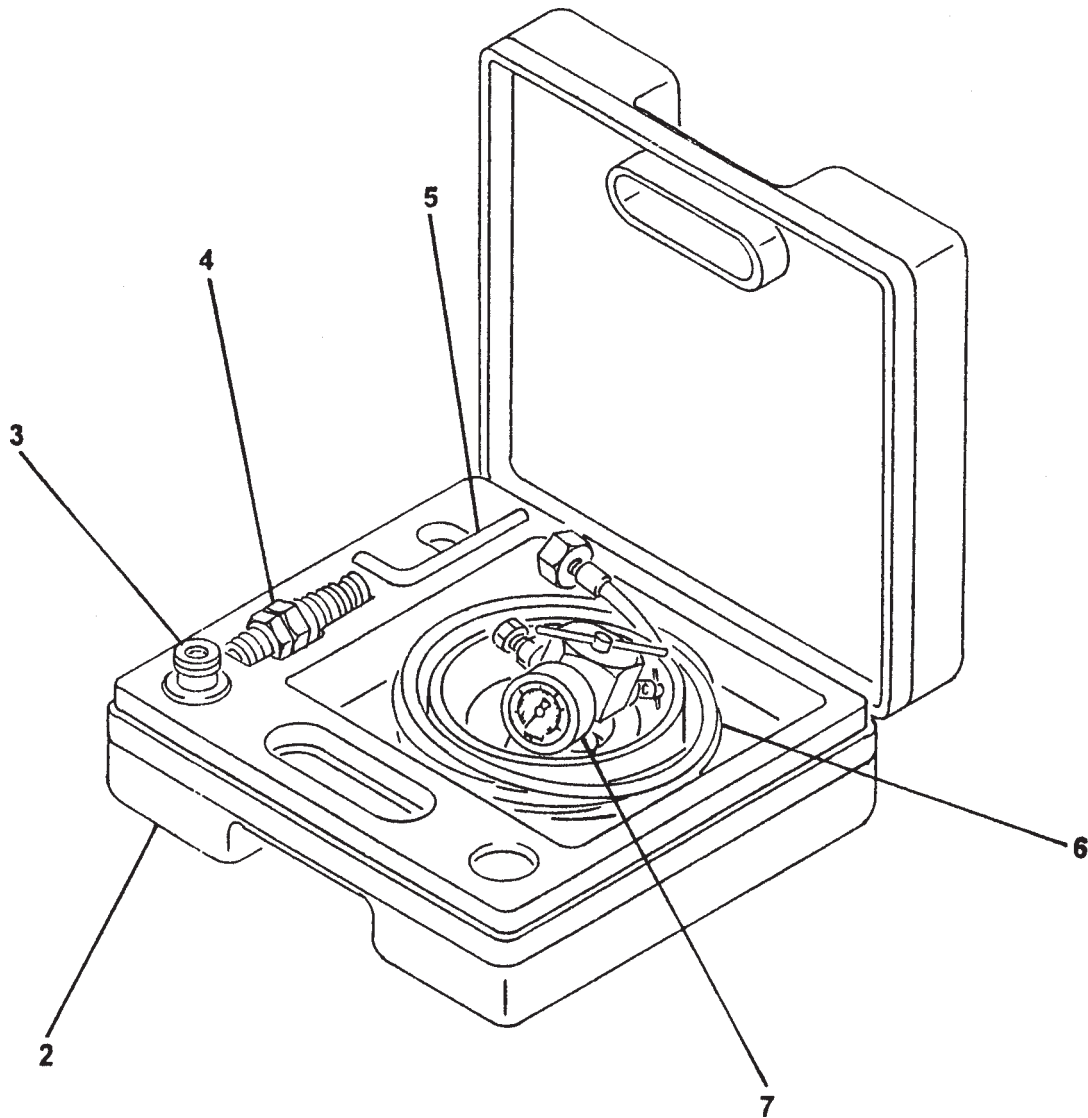





# ACCUMULATOR CHARGE KIT

**B50**  
**PARTS**  
GROUP 80  
FIGURE 06  
PAGE 02

ITEM NO.	REED'S PART NO.	DESCRIPTION					QTY
		1	2	3	4	5	
-1	71460	Kit, Accumulator Charge (See Group 80, Figure 01 for NHA)					Ref
2		• Case, Charge Kit					1
3		• Adapter, FPK / SB					1
4		• Adapter, G4					1
5		• Wrench, Allen					1
6		• Hose, Charging					1
7		• Unit, FPK Charging and Gagging					1

DASH (-) ITEM NOT ILLUSTRATED

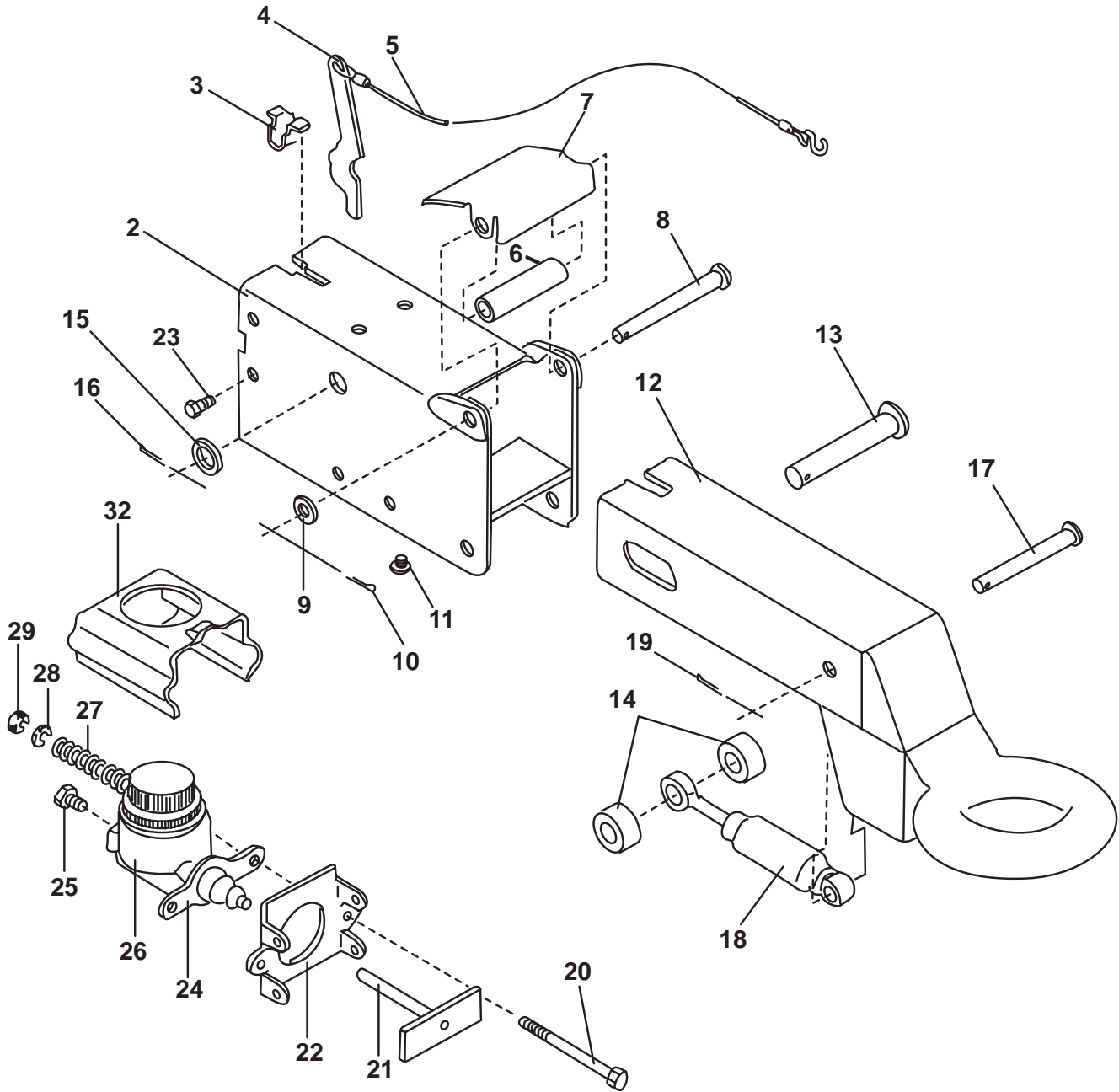



## ACTUATOR BRAKES ASSEMBLY

**B50**  
**PARTS**  
GROUP 80  
FIGURE 08  
PAGE 02

ITEM NO.	REED'S PART NO.	DESCRIPTION					QTY
		1	2	3	4	5	
-1	85807	Assembly, Actuator Brakes (See Group 80, Figure 01 for NHA)					Ref
2		• Case, Outer					1
3		• Spring, Breakaway					1
4		• Lever, Breakaway Pine					1
5		• • S-Hook					1
6		• Roller, Front					1
7		• Cover, Front Roller					1
8		• Pin, Front Roller					1
9		• Washer, Front Roller Pin					1
10		• Pin, Cotter					1
11		• Bearing					2
12		• Lunette Eye, Inner Side					1
13		• Pin, Master					1
14		• Roller, Rear					2
15		• Washer, Master Pin					1
16		• Pin, Cotter					1
17		• Pin, Damper					1
18		• Damper					1
19		• Pin, Cotter					1
20		• Bolt, Hex					2
21		• Rod, Push					1
22		• Plate, Cylinder Mounting					1
23		• Bolt, Self Tapping					4
24		• Cylinder, Master					1
25		• Connector, Orifice					1
26		• Cap, Master Cylinder with Gasket					1
27		• Spring					2
28		• Washer					2
29		• Nut, Hex					2
-30	71025	• Surge Brake Actuator, 6000 LB					1
-31	71052	• Hydraulic Brake Kit, 12IN x 2					1
-33	71026	• Brake Line Kit (Use With 71052)					1

DASH (-) ITEM NOT ILLUSTRATED

REVISION:

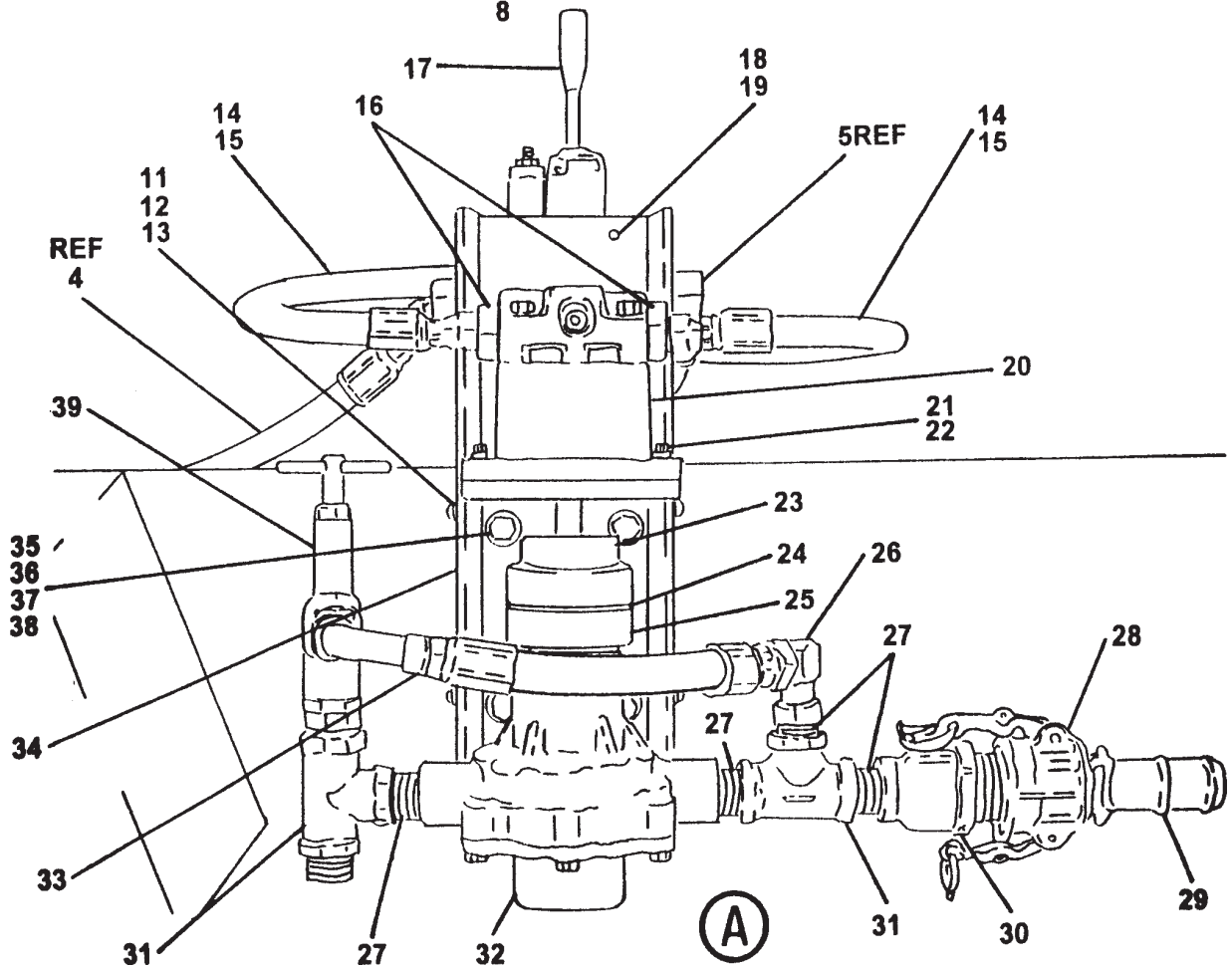
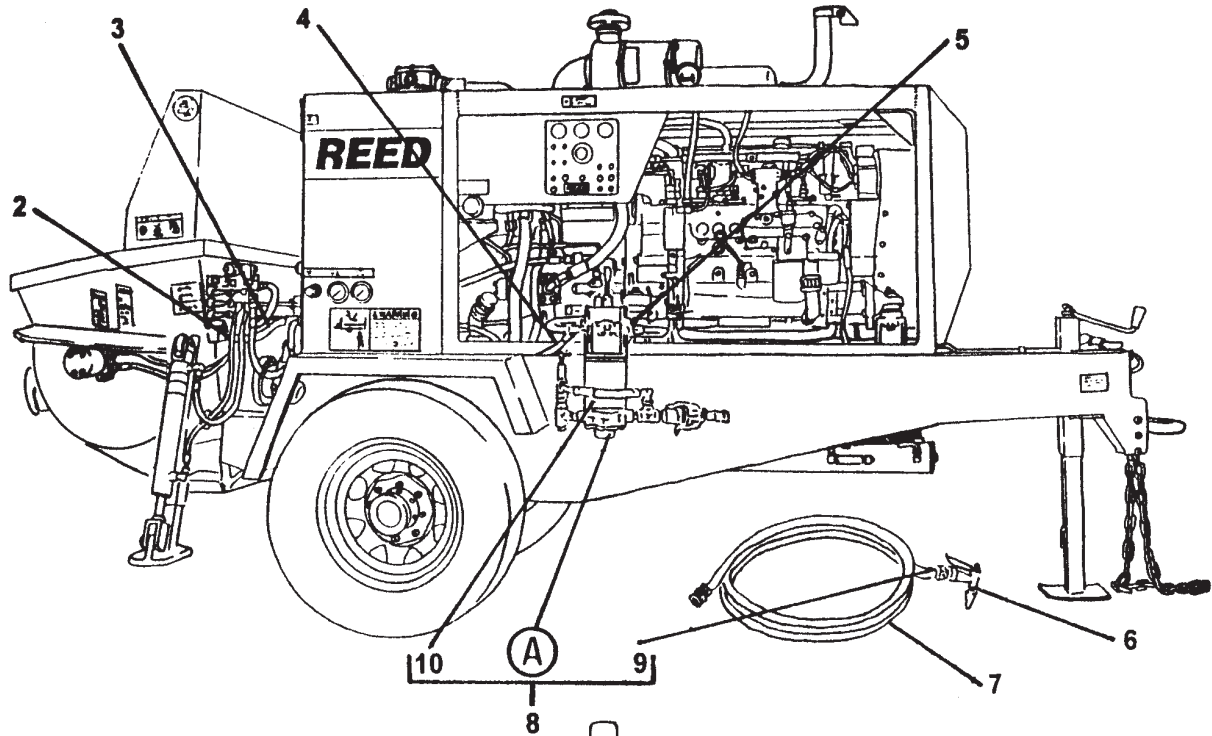



# WATER PUMP INSTALLATION

**B50**  
**PARTS**  
GROUP 80  
FIGURE 09  
PAGE 02

ITEM NO.	REED'S PART NO.	DESCRIPTION					QTY
		1	2	3	4	5	
-1	86400	Installation, Water Pump (See Group 80, Figure 01 for NHA)					Ref
2	86384	• Sleeve, Power Beyond					1
3		• Assembly, Hose					1
4		• Assembly, Hose					1
5		• Assembly, Hose					1
6	800098	• Nozzle, Garden Hose					1
7	86267	• Hose, Garden 20 FT					1
8	86200	• Kit, Wash Pump					1
9	800371	• • Fitting, Garden Hose					1
10	86199	• • Cover, Wash Pump					1
11		• • Screw (Attaching Parts)					4
12		• • Washer, SPL Lock (Attaching Parts)					4
13		• • Washer, Flat (Attaching Parts)					4
14		• • Fitting, 90					2
15	85658-002	• • Assembly, Hose					2
16		• • Fitting, STR					2
17	86397	• • Assembly, Water Pump Control Valve (See Group 80, Figure 10 for DET)					1
18		• • Bolt, (Attaching Parts)					2
19		• • Washer, SPL Lock (Attaching Parts)					2
20	78152	• • Assembly, Water Pump Motor (See Group 80, Figure 11 for DET)					1
21		• • Bolt, Hex (Attaching Parts)					2
22		• • Washer, SPL Lock (Attaching Parts)					2
23	78153	• • Coupling, Wash Motor					1
24	78155	• • Spider					1
25	78154	• • Coupling, Wash Pump					1
26		• • Fitting, 90					1
27	40047	• • Nipple, Close, Pipe					5
28	10947	• • Coupling, Female Cam / Groove					1
29	10948	• • Coupling, Male Cam / Groove					1
30	86398	• • Reducer, Bell					1
31	10228	• • Tee					2
32	78157	• • Assembly, Water Pump (See Group 80, Figure 12 for DET)					1
33	85657-022	• • Assembly, Hose					1
34	86196	• • Weldment, Wash Pump Base					1
35		• • Bolt, Hex (Attaching Parts)					4
36		• • Washer, Flat (Attaching Parts)					8
37		• • Washer, SPL Lock (Attaching Parts)					4
38		• • Nut, Lock (Attaching Parts)					4
39	78128	• • Valve, Relief					1

DASH (-) ITEM NOT ILLUSTRATED

REVISION:

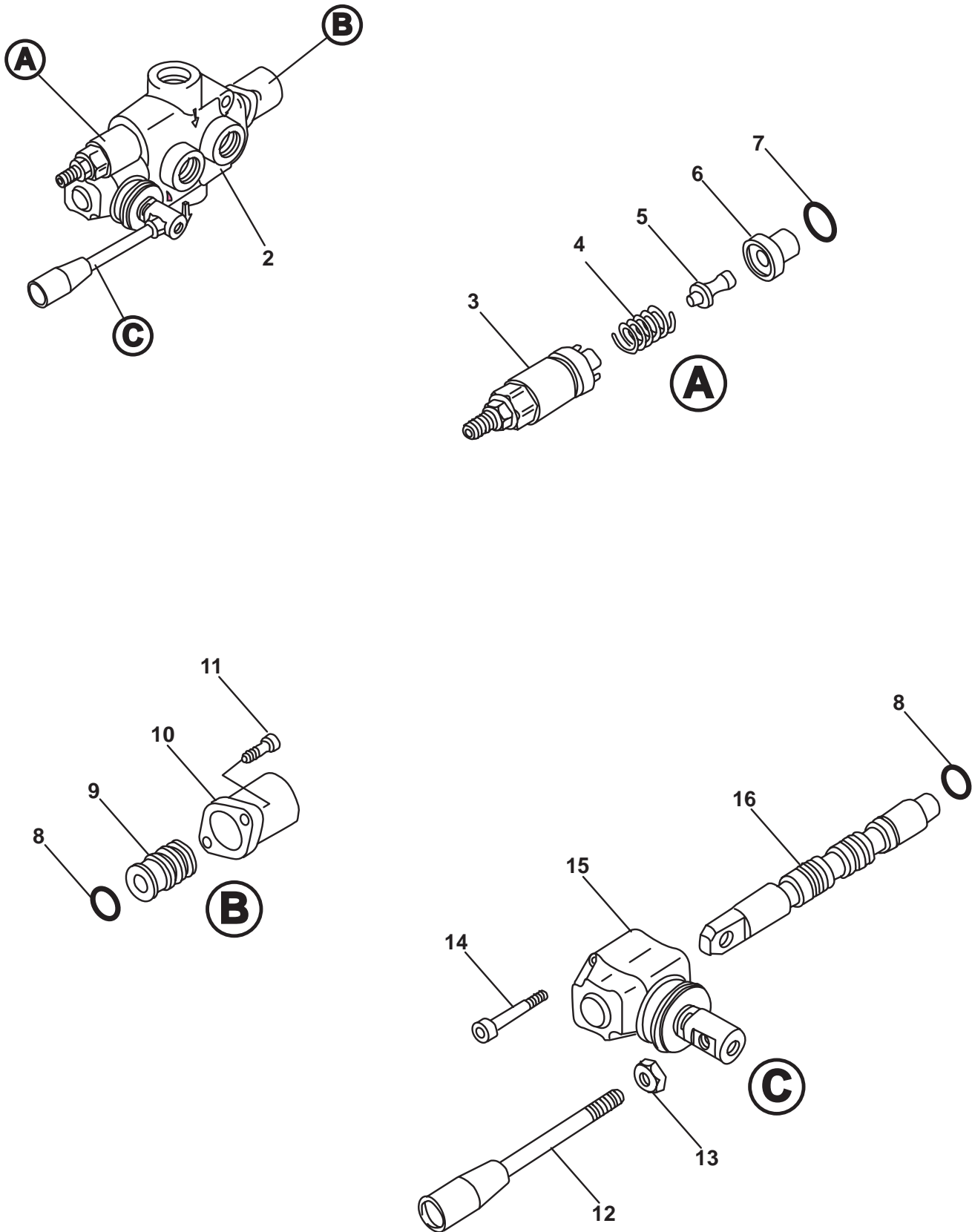



# WATER PUMP CONTROL VALVE ASSEMBLY

**B50**  
**PARTS**  
GROUP 80  
FIGURE 10  
PAGE 02

ITEM NO.	REED'S PART NO.	DESCRIPTION	QTY
		1 2 3 4 5	Ref
-1	86397	Assembly, Water Pump Control Valve (See Group 80, Figure 09 for NHA)	Ref
2		• Body, Valve	1
3		• Kit, Screw	1
4		• Spring	1
5		• Pin, Screw Kit	1
6		• Ring	1
7		• O-Ring	1
8		• O-Ring	2
9		• Kit, Spool Control	1
10		• Cap, Spool	1
11		• Screw, SOC (Attaching Parts)	2
12		• Handle, Remixer Valve	1
13		• Nut (Attaching Parts)	1
14		• Screw, SOC	2
15		• Lever, L	1
16		• Spool	1

DASH (-) ITEM NOT ILLUSTRATED

REVISION:

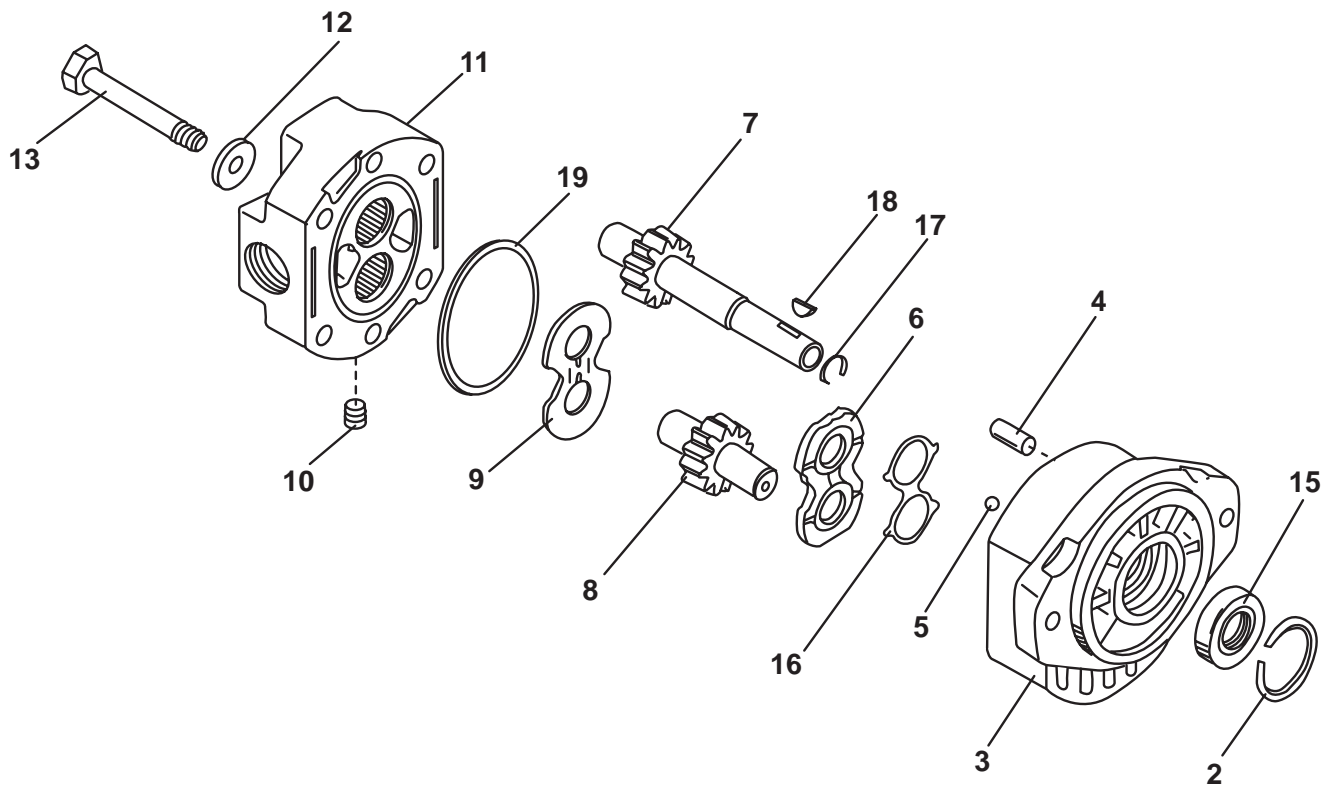





# WATER PUMP MOTOR ASSEMBLY

**B50**  
**PARTS**  
GROUP 80  
FIGURE 11  
PAGE 02

ITEM NO.	REED'S PART NO.	DESCRIPTION	QTY
		1 2 3 4 5	Ref
-1	78152	Assembly, Wash Pump Motor (See Group 80, Figure 09 for NHA)	Ref
2		• Retainer	1
3		• Assembly, body	1
4		• Pin, Dowell	2
5		• Bearing, Ball	2
6		• Plate, Wear	1
7		• Gear, Driven Wear	1
8		• Gear, Driven Wear	1
9		• Plate, Thrust	1
10		• Plug, Pipe	4
11		• Assembly, Cover	1
12		• Washer (Attaching Parts)	4
13		• Screw, Hex (Attaching Parts)	4
14		• Kit, Seal	1
15		• • Brush	1
16		• • Cap, Brush	1
17		• • Gasket	1
18		• • Cover, Brush	1

DASH (-) ITEM NOT ILLUSTRATED

REVISION:

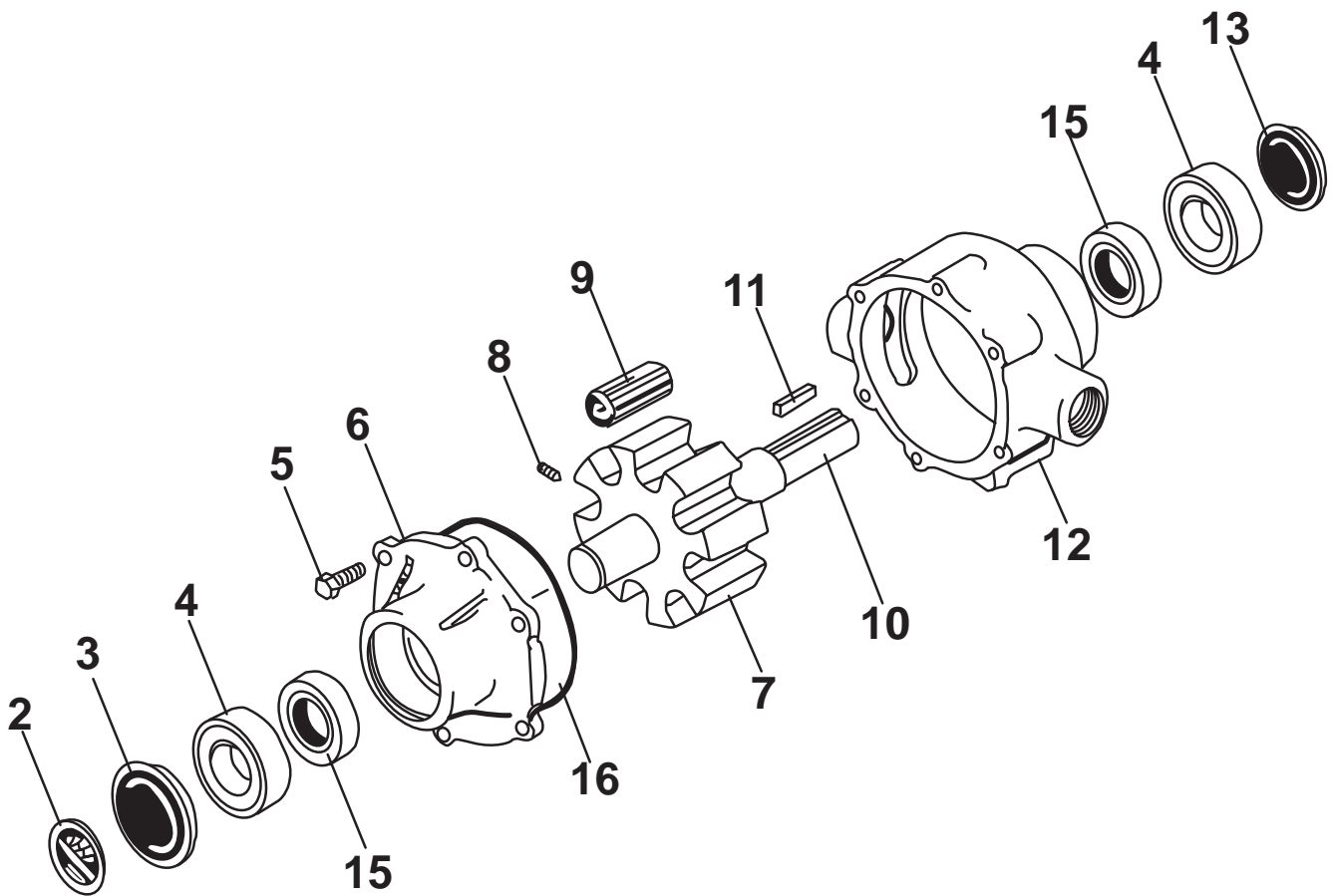



# WATER PUMP ASSEMBLY

**B50**  
**PARTS**  
GROUP 80  
FIGURE 12  
PAGE 02

ITEM NO.	REED'S PART NO.	DESCRIPTION	QTY
		1 2 3 4 5	
-1	78157	Assembly, Wash Water Pump (See Group 80, Figure 09 for NHA)	Ref
2		• Plate, Name	1
3		• Cover, Bearing Rear	1
4		• Bearing, Sealed Bowl	2
5		• Endplate, (Ni-Resist) with Seal	1
6		• Bolt, Hex (Attaching Parts)	6
7		• Rotor, (Ni-Resist) with Shaft	1
8		• Screw, Set (Attaching Parts)	1
9		• Roller, Teflon	1
10		• Shaft	1
11		• Key	1
12		• Body, (Ni-Resist) with Seal	1
13		• Cover, Bearing Shaft	1
-14	72329	• Kit, Seal	1
15		• • Seal, Buna	2
16		• • Gasket, End Plate O-Ring	1

DASH (-) ITEM NOT ILLUSTRATED

REVISION:

## NON-OPERATOR SIDE HYDRAULIC BRAKE ASSEMBLY

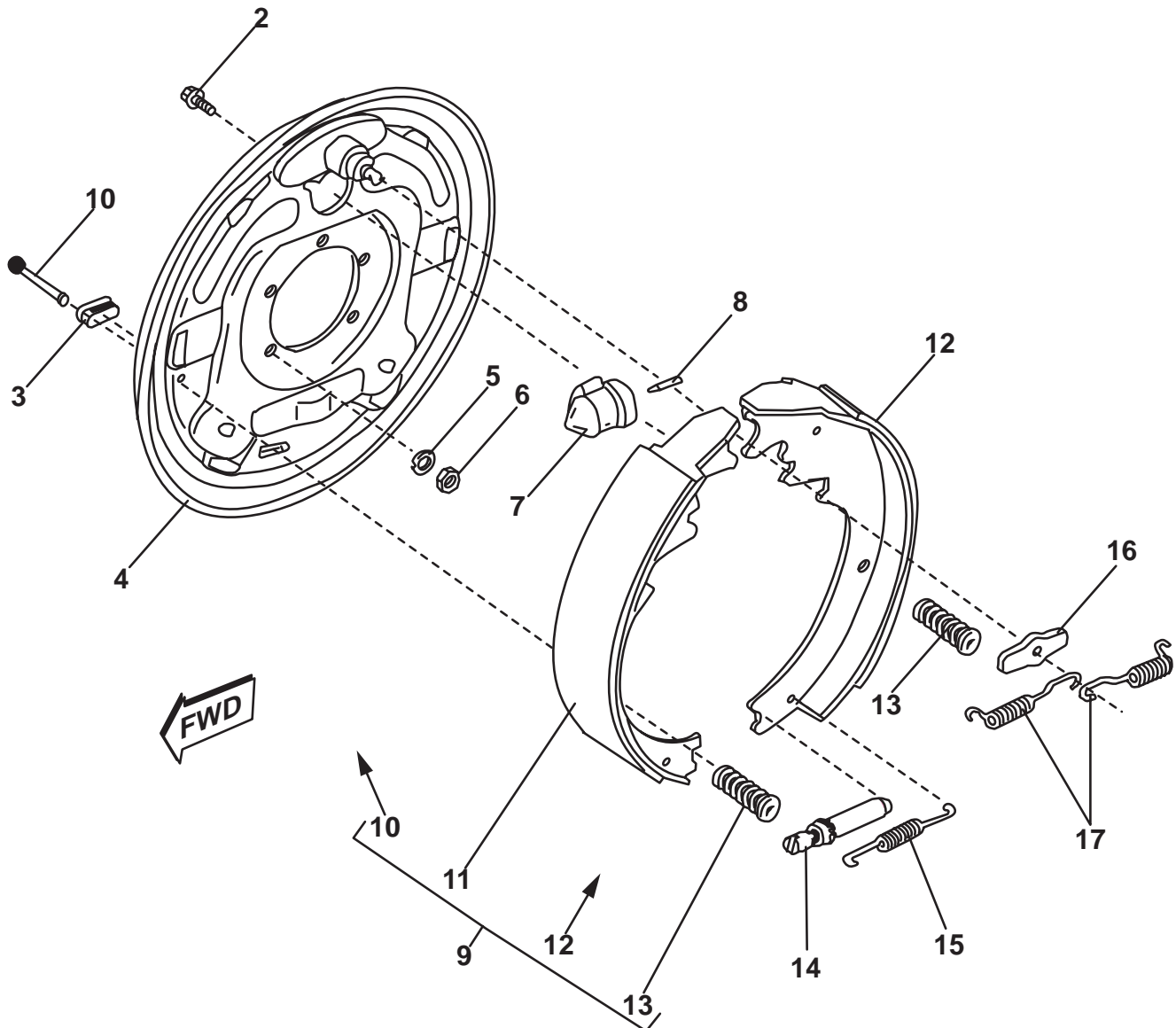



## NON-OPERATOR SIDE HYDRAULIC BRAKE ASSEMBLY

**B50**  
**PARTS**  
GROUP 80  
FIGURE 13  
PAGE 02

ITEM NO.	REED'S PART NO.	DESCRIPTION					QTY
		1	2	3	4	5	
-1	80-12	Assembly, Non-Operator Side Hydraulic Brake (See Group 80, Figure 01 for NHA)					Ref
2		• Screw, with Washer					1
3		• Plug					2
4		• Plate, Backing					1
5		• Washer, Lock (Attaching Parts)					5
6		• Nut, Brake Mounting (Attaching Parts)					5
7		• Cylinder, Non-Operator Side Brake					1
8		• Rod, Push					1
9		• Kit, Non-Operator Side Shoe and Lining					1
10		• • Pin, Shoe Hold Down					2
11		• • Primary, Non-Operator Side					1
12		• • Secondary, Non-Operator Side					1
13		• • Pin, Shoe Hold Down					2
14		• Assembly, Adjuster					1
15		• Spring, Adjusting Screw					1
16		• Washer, Anchor Post					1
17		• Spring, Retractor					2

DASH (-) ITEM NOT ILLUSTRATED

REVISION:

## OPERATOR SIDE HYDRAULIC BRAKE ASSEMBLY

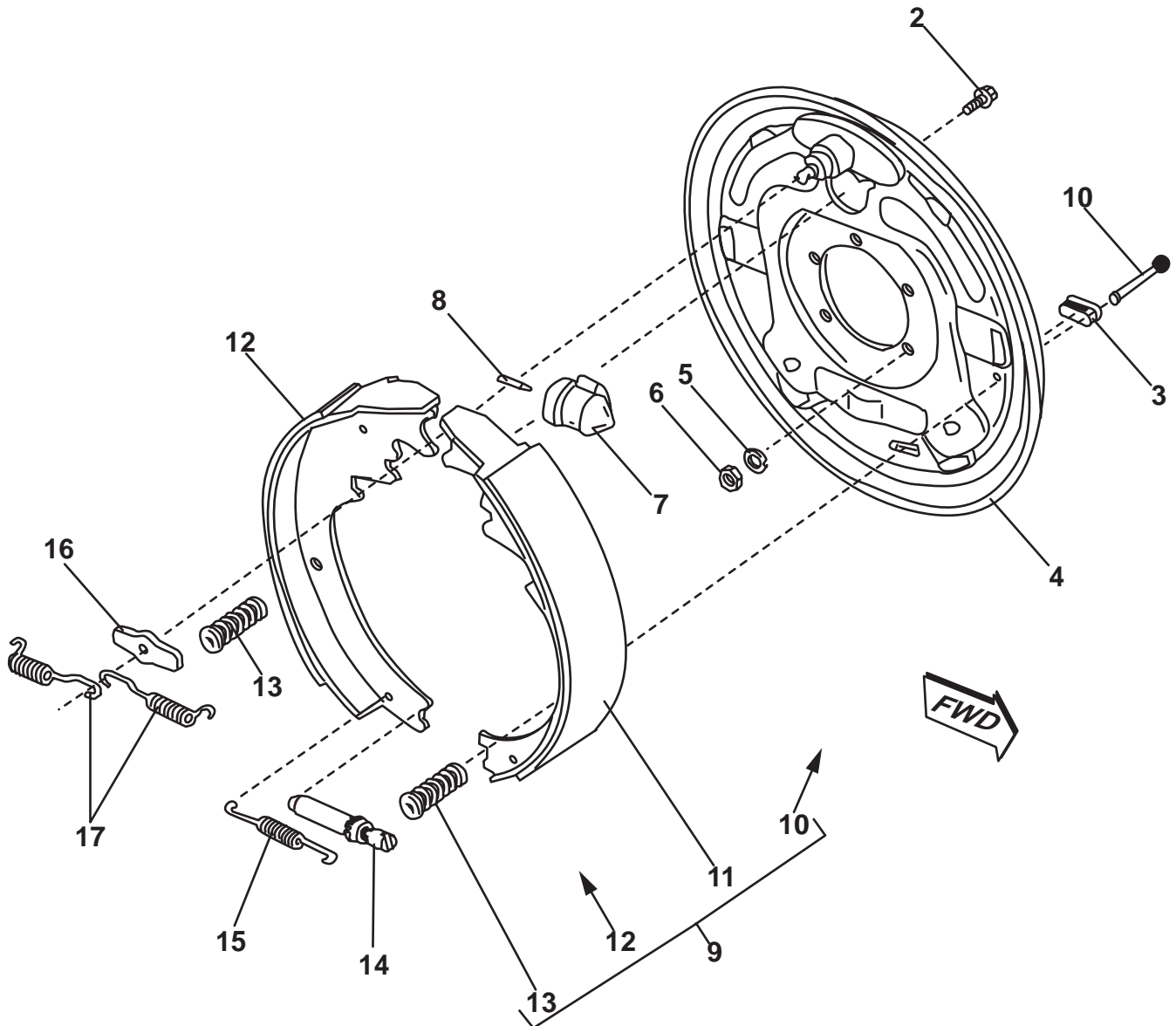



# OPERATOR SIDE HYDRAULIC BRAKE ASSEMBLY

**B50**  
**PARTS**  
GROUP 80  
FIGURE 14  
PAGE 02

ITEM NO.	REED'S PART NO.	DESCRIPTION	QTY
		1 2 3 4 5	
-1	80-13	Assembly, Non-Operator Side Hydraulic Brake (See Group 80, Figure 01 for NHA)	Ref
2		• Screw, with Washer	1
3		• Plug	2
4		• Plate, Backing	1
5		• Washer, Lock (Attaching Parts)	5
6		• Nut, Brake Mounting (Attaching Parts)	5
7		• Cylinder, Operator Side Brake	1
8		• Rod, Push	1
9		• Kit, Operator Side Shoe and Lining	1
10		• • Pin, Shoe Hold Down	2
11		• • Primary, Operator Side	1
12		• • Secondary, Operator Side	1
13		• • Pin, Shoe Hold Down	2
14		• Assembly, Adjuster	1
15		• Spring, Adjusting Screw	1
16		• Washer, Anchor Post	1
17		• Spring, Retractor	2

DASH (-) ITEM NOT ILLUSTRATED

REVISION:

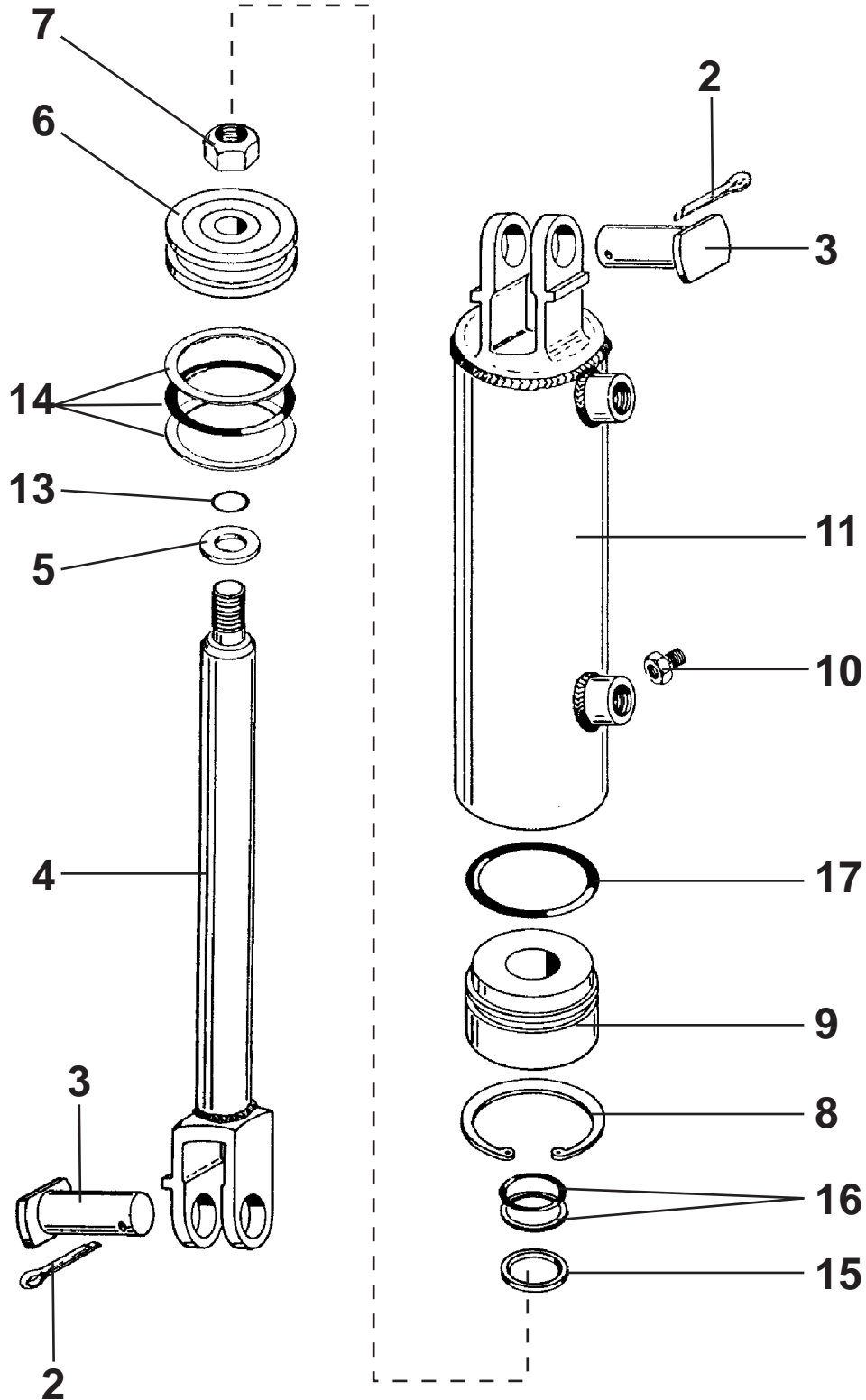





# HYDRAULIC OUTRIGGER CYLINDER ASSEMBLY

**B50**  
**PARTS**  
GROUP 80  
FIGURE 15  
PAGE 02

ITEM NO.	REED'S PART NO.	DESCRIPTION					QTY
		1	2	3	4	5	
-1	85640	Assembly, Hydraulic Outrigger Cylinder (See Group 80, Figure 01 for NHA)					Ref
2		• Pin, Safety					2
3		• Pin, Clevis					2
4		• Assembly, Shaft					1
5		• Washer, Steel					1
6		• Piston					1
7		• Nut, Piston Lock					1
8		• Ring, Head Lock					1
9		• Head					1
10		• Screw, Head Set					1
11		• Assembly, Tube					1
12	74497	• Kit, Seal					1
13		• • O-Ring, Small					1
14		• • Sub-Assembly, Piston O-Ring					1
15		• • Wiper, Rod					1
16		• • Packing, Shaft (Pair)					1
17		• • O-Ring, Head					1

DASH (-) ITEM NOT ILLUSTRATED

REVISION:



# 1 SPOOL CONTROL VALVE ASSEMBLY

B50  
PARTS  
GROUP 80  
FIGURE 16  
PAGE 01

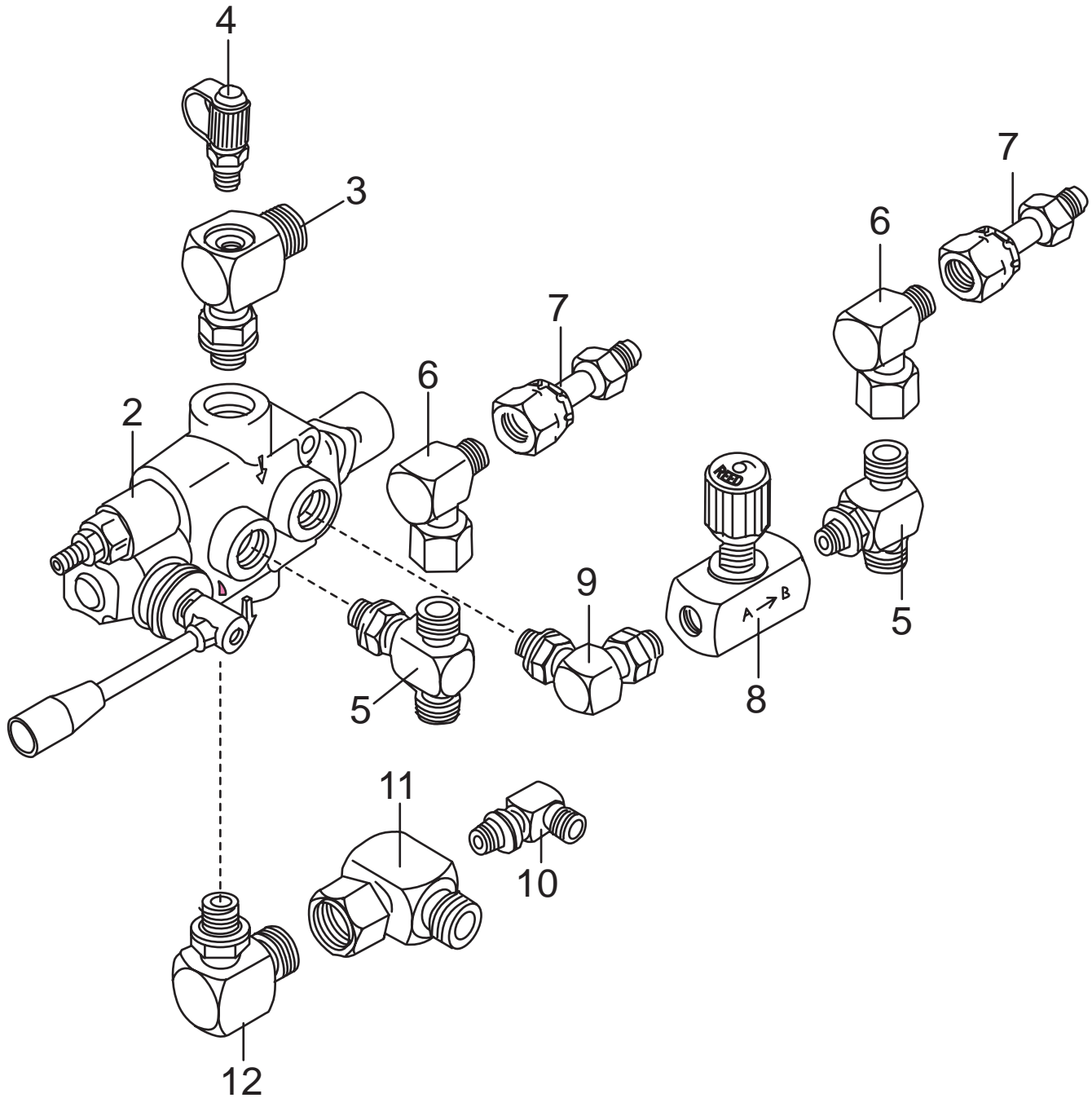

REVISION:



# 1 SPOOL CONTROL VALVE ASSEMBLY

**B50**  
**PARTS**  
GROUP 80  
FIGURE 16  
PAGE 02

ITEM NO.	REED'S PART NO.	DESCRIPTION	QTY
		1 2 3 4 5	
-1	80-16	Assembly, 1 Spool Control Valve (See Group 80, Figure 01 for NHA)	Ref
2	74584	• Sub-Assembly, 1 Spool Control Valve (See Group 80, Figure 17 for DET)	1
3		• Tee, Special Drill	1
4	78593	• Fitting, Mini Check (Port)	1
5		• Tee	2
6		• Fitting, 90	2
7		• Fitting, Connector	2
8		• Controller, Check	1
9		• Fitting, 90	1
10		• Fitting, 90	1
11		• Tee, Special Drill	1
12		• Fitting, 90	1

DASH (-) ITEM NOT ILLUSTRATED

REVISION:

## 1 SPOOL CONTROL VALVE SUBASSEMBLY

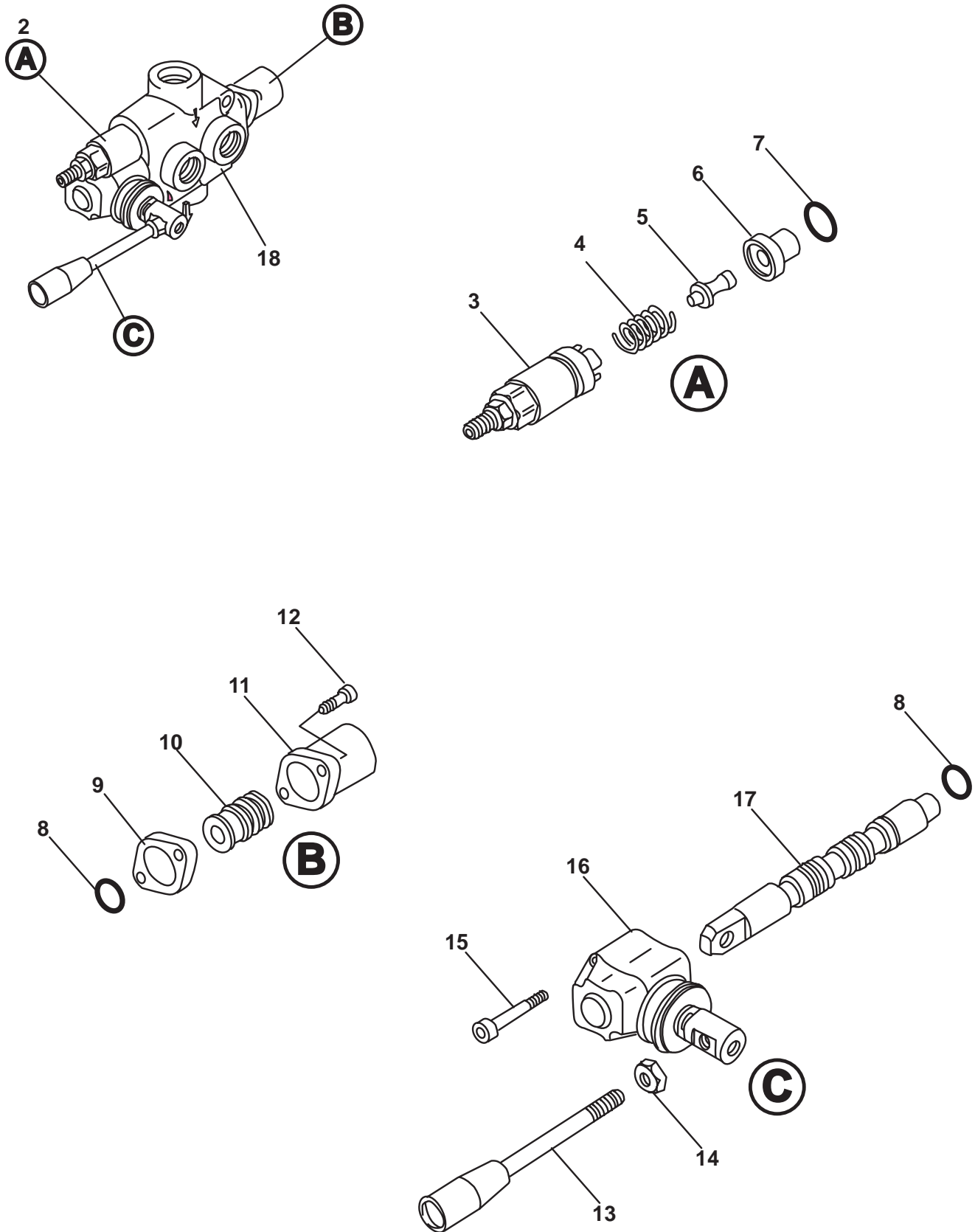



# 1 SPOOL CONTROL VALVE SUBASSEMBLY

**B50**  
**PARTS**  
GROUP 10  
FIGURE 17  
PAGE 02

ITEM NO.	REED'S PART NO.	DESCRIPTION					QTY
		1	2	3	4	5	
-1	74584	Sub-Assembly, 1 Spool Control Valve (See Group 80, Figure 16 for NHA)					Ref
2	85706	•• Cartidge, Relief					1
3		•• Kit, Screw					1
4		•• Spring					1
5		•• Pin, Screw Kit					1
6		•• Ring					1
7		•• O-Ring					1
8		• O-Ring					2
9		• Spacer					1
10		• Kit, Spool, Control					1
11		• Cap, Spool					1
12		• Screw, SOC (Attaching Parts)					2
13		• Handle, Remixer Valve					1
14		• Nut (Attaching Parts)					1
15		• Screw, SOC					2
16		• Lever, L					1
17		• Spool					1
18		• Body, Valve					1

DASH (-) ITEM NOT ILLUSTRATED

REVISION:

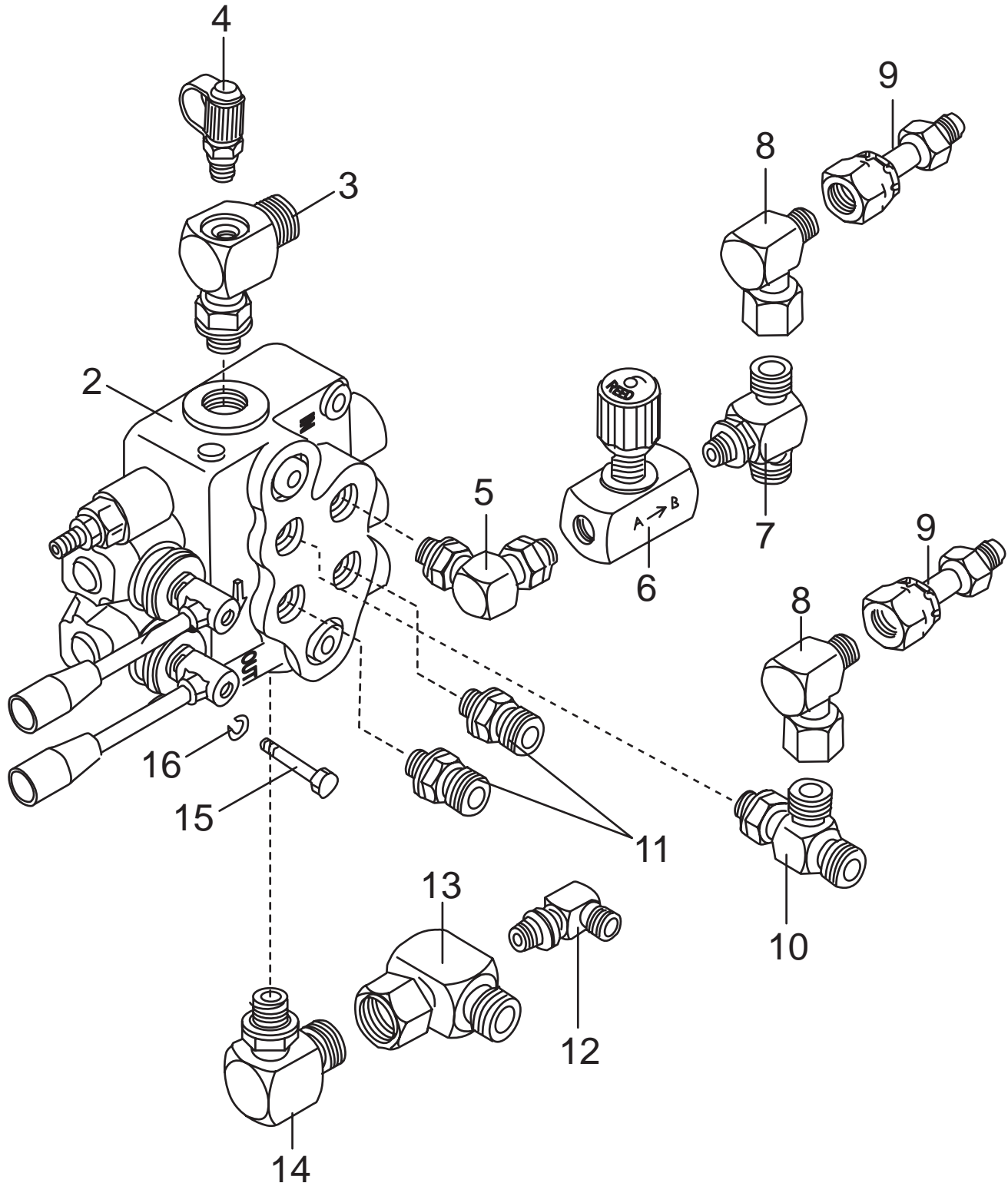



## 2 SPOOL CONTROL VALVE ASSEMBLY

**B50**  
**PARTS**  
GROUP 80  
FIGURE 18  
PAGE 02

ITEM NO.	REED'S PART NO.	DESCRIPTION					QTY
		1	2	3	4	5	
-1	80-18	Assembly, 2 Spool Control Valve (See Group 80, Figure 01 for NHA)					Ref
2	74585	• Sub-Assembly, 2 Spool Control Valve (See Group 80, Figure 20 for DET)					1
3		• tee, Special Drill					1
4	78593	• Fitting, Mini Check (Port)					1
5		• Fitting, 90					1
6		• Controller, Check					1
7		• Tee					1
8		• Fitting					2
9		• Fitting, Connector					1
10		• Tee					1
11		• Fitting, 90					2
12		• Fitting, 90					1
13		• Tee, Special Drill					1
14		• Fitting, 90					1
15		• Bolt, Hex					2
16		• Washer, SPL Lock					2

DASH (-) ITEM NOT ILLUSTRATED

REVISION:



# 2 SPOOL CONTROL VALVE SUBASSEMBLY

**B50**  
**PARTS**  
GROUP 80  
FIGURE 19  
PAGE 01

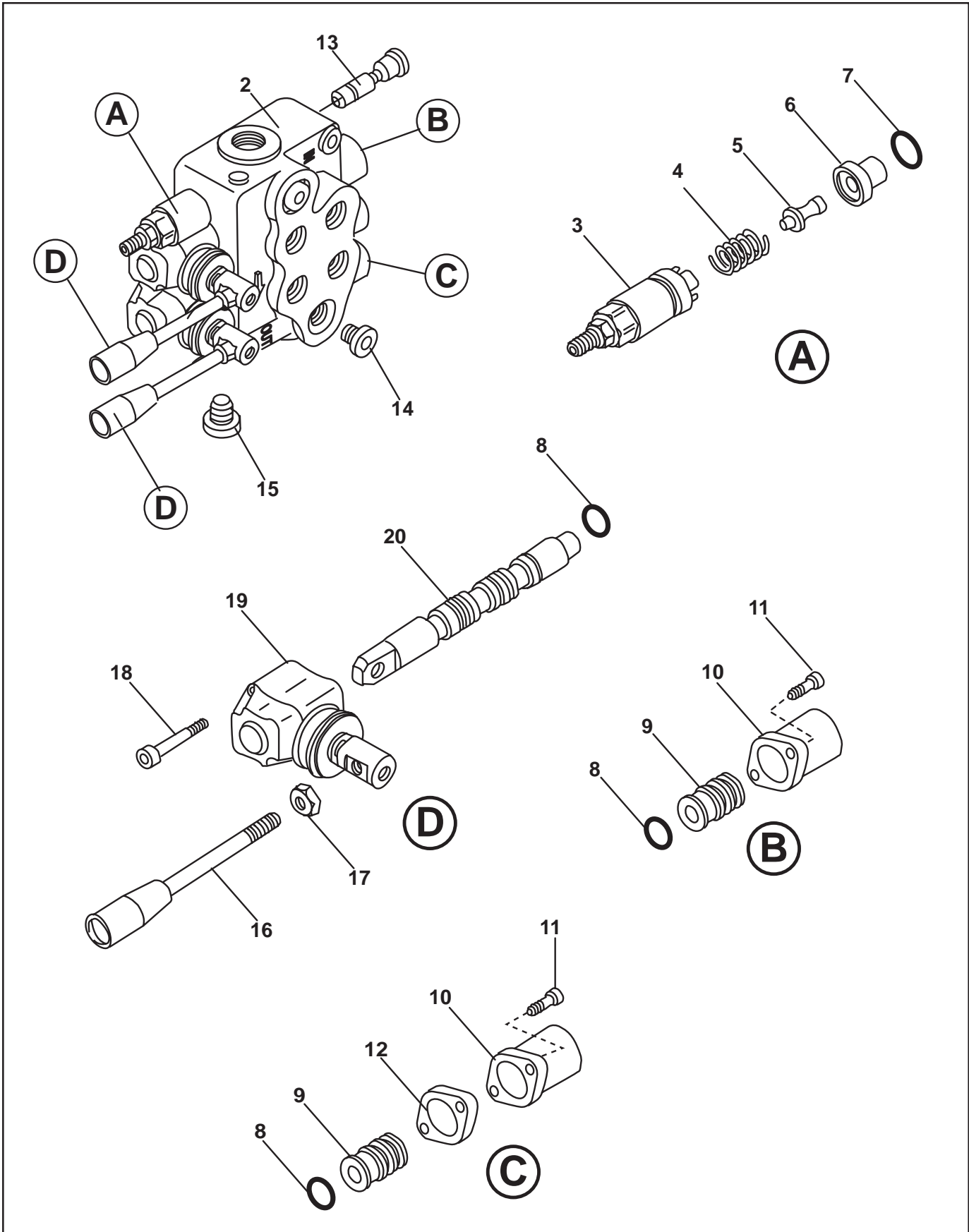

REVISION:





## 2 SPOOL CONTROL VALVE SUBASSEMBLY

**B50**  
**PARTS**  
GROUP 80  
FIGURE 19  
PAGE 02

ITEM NO.	REED'S PART NO.	DESCRIPTION					QTY
		1	2	3	4	5	
-1	74585	Sub-Assembly, 2 Spool Control Valve (See Group 80, Figure 18 for NHA)					Ref
2	85706	• Cartridge, Relief					1
3		• • Kit, Screw					1
4		• • Spring					1
5		• • Pin, Screw Kit					1
6		• • Ring					1
7		• • O-Ring					1
8		• O-ring					4
9		• Kit, Spool Control					2
10		• Cap, Spool					2
11		• Screw, SOC (Attaching Parts)					4
12		• Spacer					1
13		• Kit, VRS					1
14		• Plug					2
15		• Plug					1
16		• Handle, Remixer Valve					2
17		• Nut (Attaching Parts)					2
18		• Screw, SOC					4
19		• Lever, L					2
20		• Spool					2
21		• Body, Valve					1

DASH (-) ITEM NOT ILLUSTRATED

REVISION:



# SIDE DOOR ASSEMBLY

**B50**  
**PARTS**  
GROUP 80  
FIGURE 20  
PAGE 01

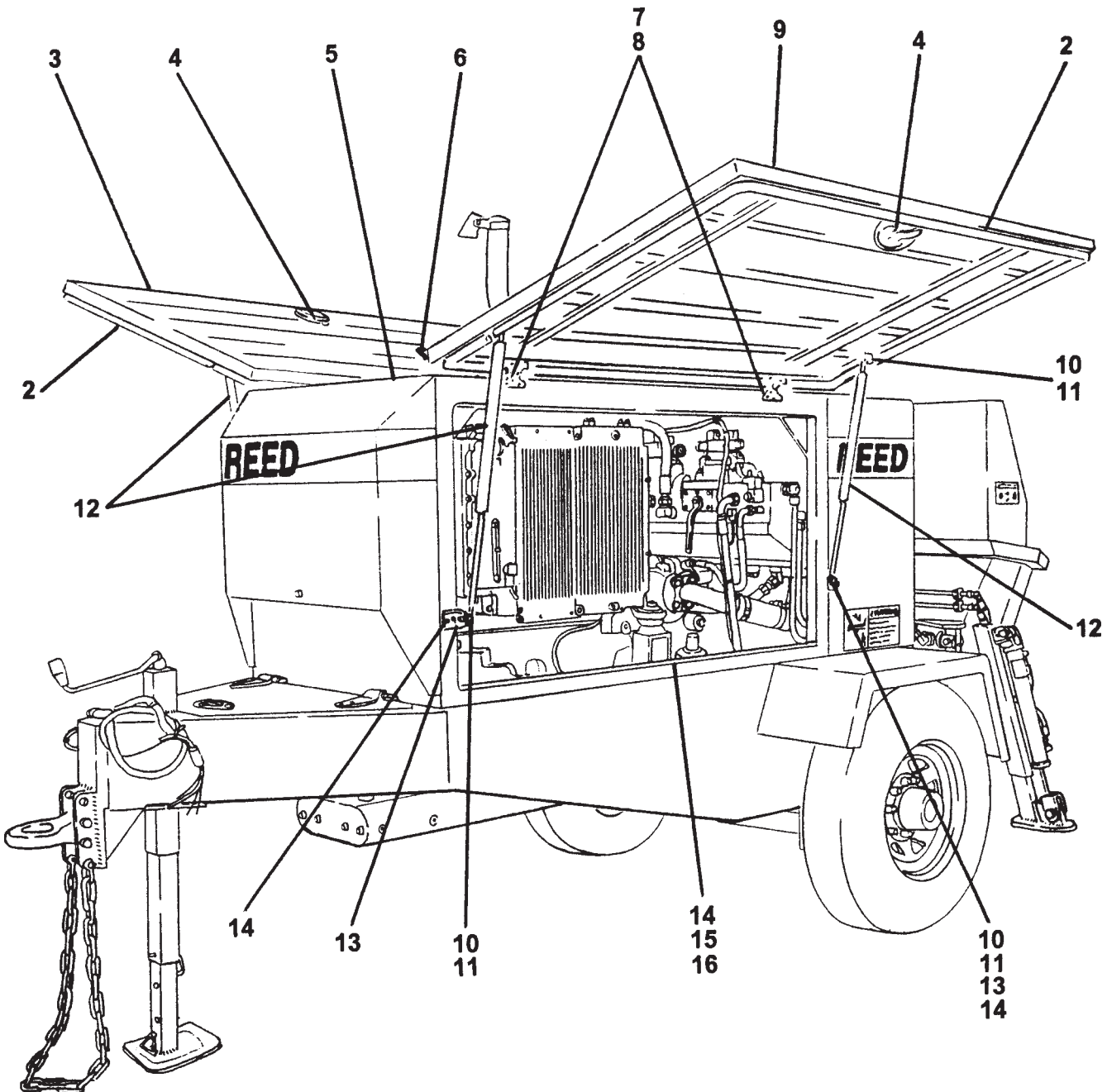

REVISION:



# SIDE DOOR ASSEMBLY

**B50**  
**PARTS**  
GROUP 80  
FIGURE 20  
PAGE 02

ITEM NO.	REED'S PART NO.	DESCRIPTION					QTY
		1	2	3	4	5	
-1	85943	Assembly, B-Series Side Door (See Group 80, Figure 01 for NHA)					Ref
2	73163	• Seal, 3/8 Bulb 15.75 FT Trim					A/R
3	85968	• Weldment, B-Series Right Hand Side Door					1
4	73767	• Latch, D Ring with Key					2
5	86144	• Structure, Lifting					1
6	71364	• Seal, 3/8 Bulb 3.5 FT Trim					A/R
7	85928	• Hinge, Machining					4
8	85945	• Screw, Button Head Cap					12
9	85967	• Weldment, B-Series Left Hand Door					1
10	75215	• Stud, Ball					8
11		• Washer, Flat					A/R
12	75214	• Spring, 130 LBS Gas					4
13	85931	• Tab, Frame Gas Spring					2
14	85944	• Screw, Button Head Cap					16
15	85939	• Angle, Left Hand Side Door					1
16	85940	• Angle, Right Hand Side Door					1

DASH (-) ITEM NOT ILLUSTRATED

REVISION:

## 50 FEET STROKE COUNTER CABLE REMOTE CONTROL ASSEMBLY

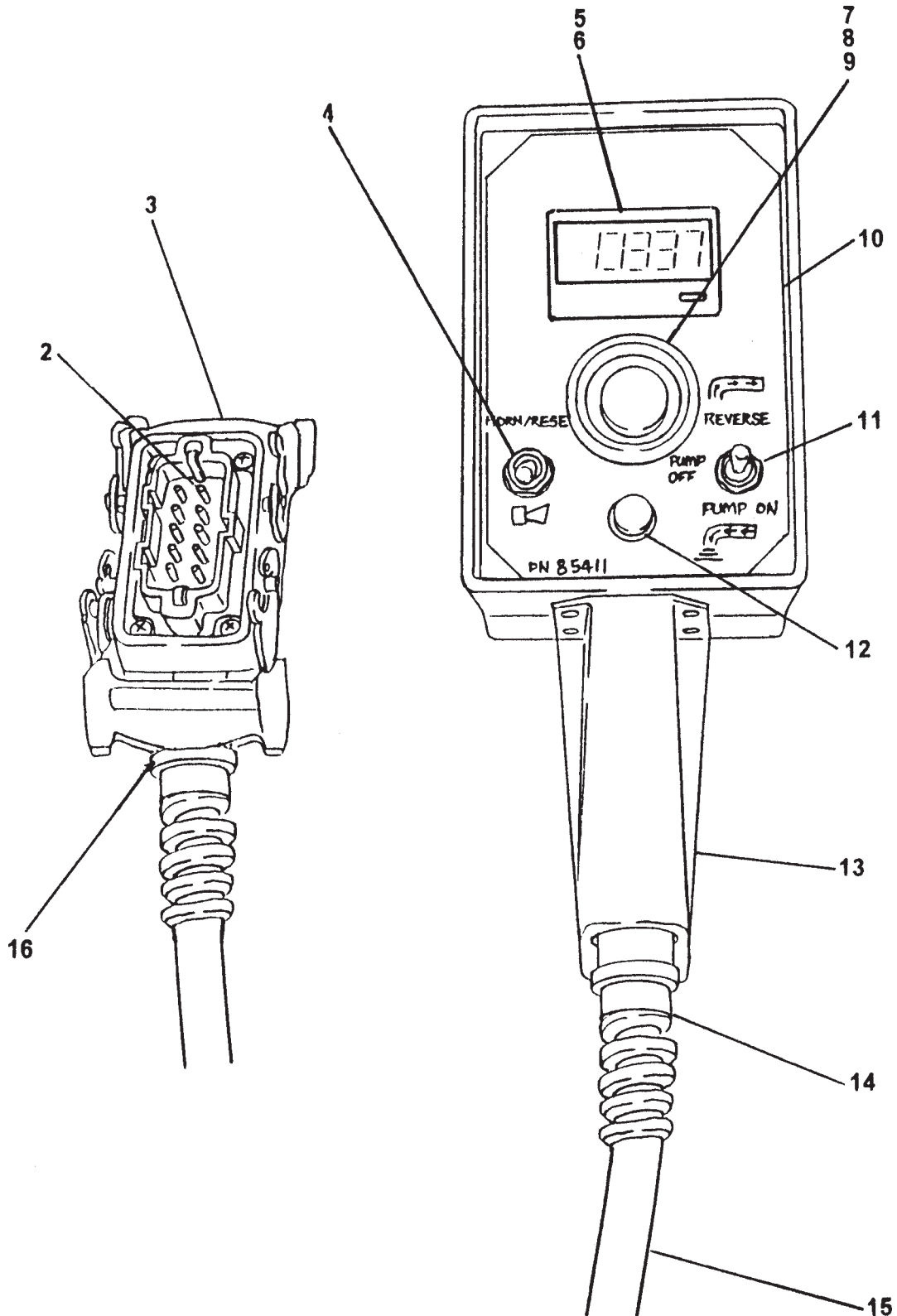



# 50 FEET STROKE COUNTER CABLE REMOTE CONTROL ASSEMBLY

**B50**  
**PARTS**  
GROUP 80  
FIGURE 21  
PAGE 02

ITEM NO.	REED'S PART NO.	DESCRIPTION	QTY
		1 2 3 4 5	
-1	85960	Assembly, 50 FT Cable Remote Control w/Stroke Counter (See Group 80, Figure 01 for NHA)	Ref
2	79964	• Connector, Insert	1
3	79966	• Connector, Hood	1
4	85347	• Switch, Horn / Reset	1
5	72330	• Counter, Stroke	1
6	74388	• Diode, Stroke Counter	1
7	85342	• Operator, Emergency Stop	1
8	85343	• Block, 1 NC Lighted Contact	1
9	85344	• Bulb, Emergency Stop	1
10	85411	• Decal, C-Series Remote Control Box	1
11	72003	• Switch, Pump On / Reverse	1
12	85355	• Pilot, Light	1
13	85961	• Enclosure, Remote Control	1
14	86133	• Relief, PG-11 Spiral Strain	1
15	85620	• Cable, 50 Feet Remote Control	1
16	86145	• Reducer, PG-16 to PG-11	1
17	72777	• Resistor, Green 100 OHM	1

REVISION:

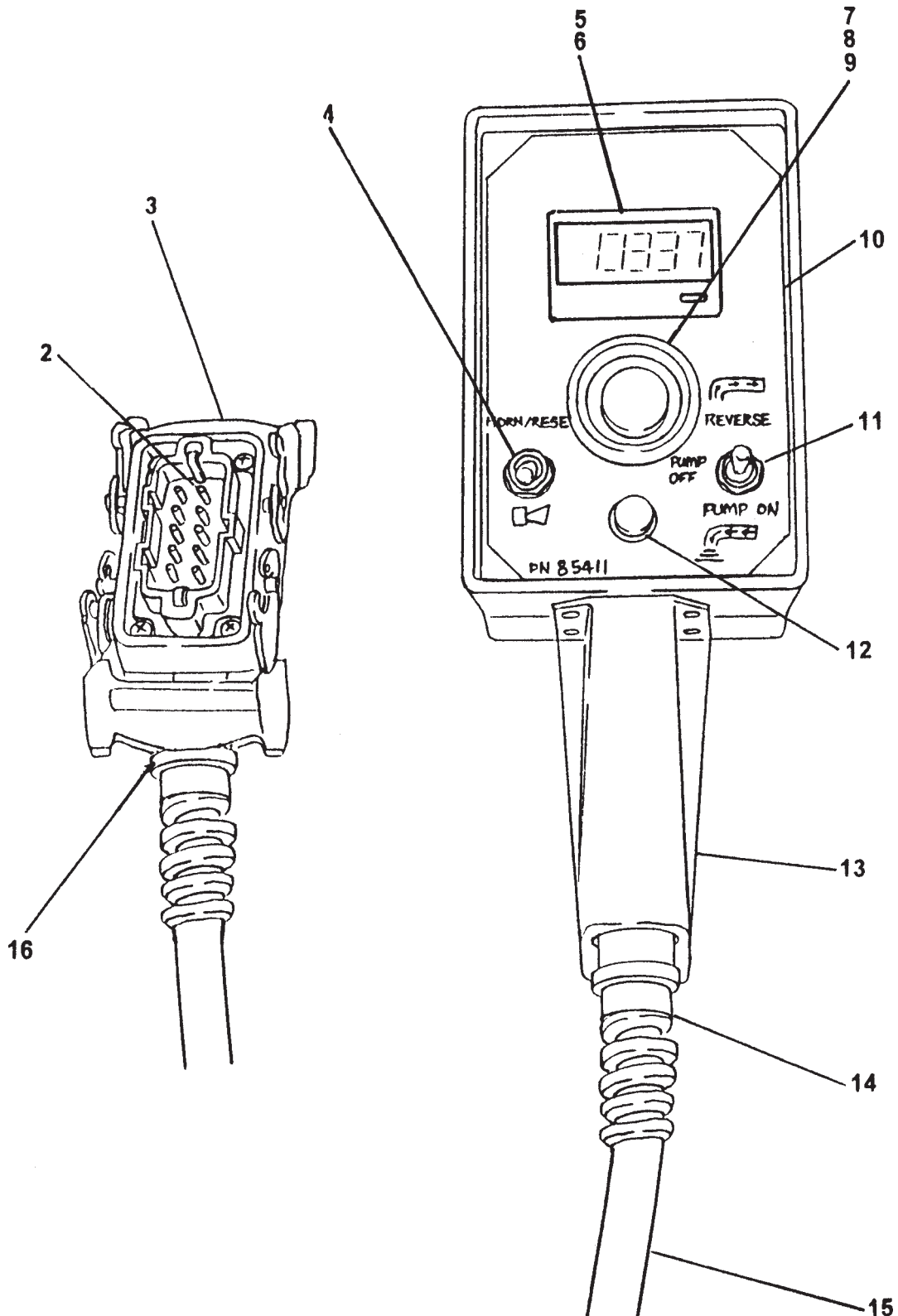



# 100 FEET STROKE COUNTER CABLE REMOTE CONTROL ASSEMBLY

**B50**  
**PARTS**  
GROUP 80  
FIGURE 22  
PAGE 02

ITEM NO.	REED'S PART NO.	DESCRIPTION	QTY
		1 2 3 4 5	
-1	85960A	Assembly, 100 FT Cable Remote Control w/Stroke Counter (See Group 80, Figure 01 for NHA)	<b>Ref</b>
2	79964	• Connector, Insert	1
3	79966	• Connector, Hood	1
4	85347	• Switch, Horn / Reset	1
5	72330	• Counter, Stroke	1
6	74388	• Diode, Stroke Counter	1
7	85342	• Operator, Emergency Stop	1
8	85343	• Block, 1 NC Lighted Contact	1
9	85344	• Bulb, Emergency Stop	1
10	85411	• Decal, C-Series Remote Control Box	1
11	72003	• Switch, Pump On / Reverse	1
12	85355	• Pilot, Light	1
13	85961	• Enclosure, Remote Control	1
14	86133	• Relief, PG-11 Spiral Strain	1
15	85816	• Cable, 100 Feet Remote Control	1
16	86145	• Reducer, PG-16 to PG-11	1
17	72777	• Resistor, Green 100 OHM	1

DASH (-) ITEM NOT ILLUSTRATED

REVISION: