



**TRAILER MOUNTED PUMP 02 MODEL B50
SINGLE SHIFT SWING TUBE CIRCUIT
HYDRAULIC COMPONENTS & SCHEMATIC**

SCMTC

PAGE 02

B & C SERIES SWING TUBE HYDRAULIC
SCHEMATIC, SINGLE SHIFT CYLINDER

DATE
11/7/01

REV.

PART NO.
86705

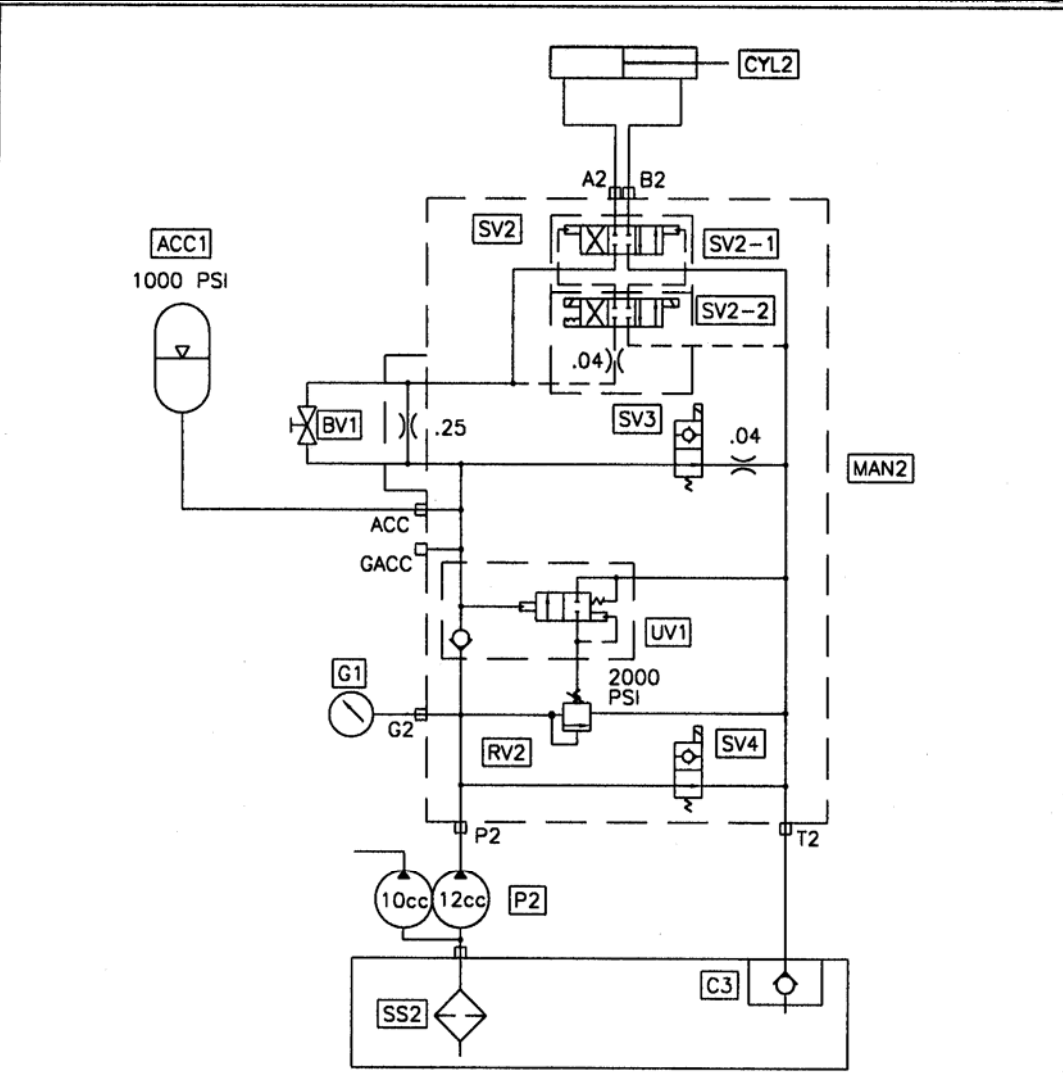

CODE	DESCRIPTION	PART NO.	QTY.
P2	Gear Pump, Parts, Group 40	73156	1
CYL2	S Tube Single Shift Cylinder	86221	1
MAN2	Manifold S Tube Circuit	85249	1
SV2	Solenoid Valve S Tube Circuit	85693	1
SV2-1	Solenoid Valve Main	85694	1
SV2-2	Solenoid Valve Pilot	85695	1
	Coil For SV2-2	85692	2
SV3	Solenoid Valve Cartridge	85699	1
	Coil For SV3	85700	1
SV4	Solenoid Valve Cartridge	85701	1
	Coil For SV4	85702	1
RV2	Relife Valve Cartridge	85703	1
UN1	Unlodng Valve Cartridge	85704	1
BV1	Ball Valve	85705	1
AAC1	Accumulator	74515	1
	Accumulator, Bladder	74516	1
G2	Pressure Gauge 3000 PSI	70366	1
SS2	Magnetic Suction Strainer 1 1/4"	79247	1
C3	Check Valve	85574	1

REVISION:



**TRAILER MOUNTED PUMP 02 MODEL B50
AGITATOR / OUTRIGGER OPTION CIRCUIT
HYDRAULIC COMPONENTS & SCHEMATIC**

SCMTC

PAGE 04

B & C SERIES SWING TUBE HYDRAULIC
SCHEMATIC, DUAL SHIFT CYLINDER

DATE
11/7/01

REV.

PART NO.
86706

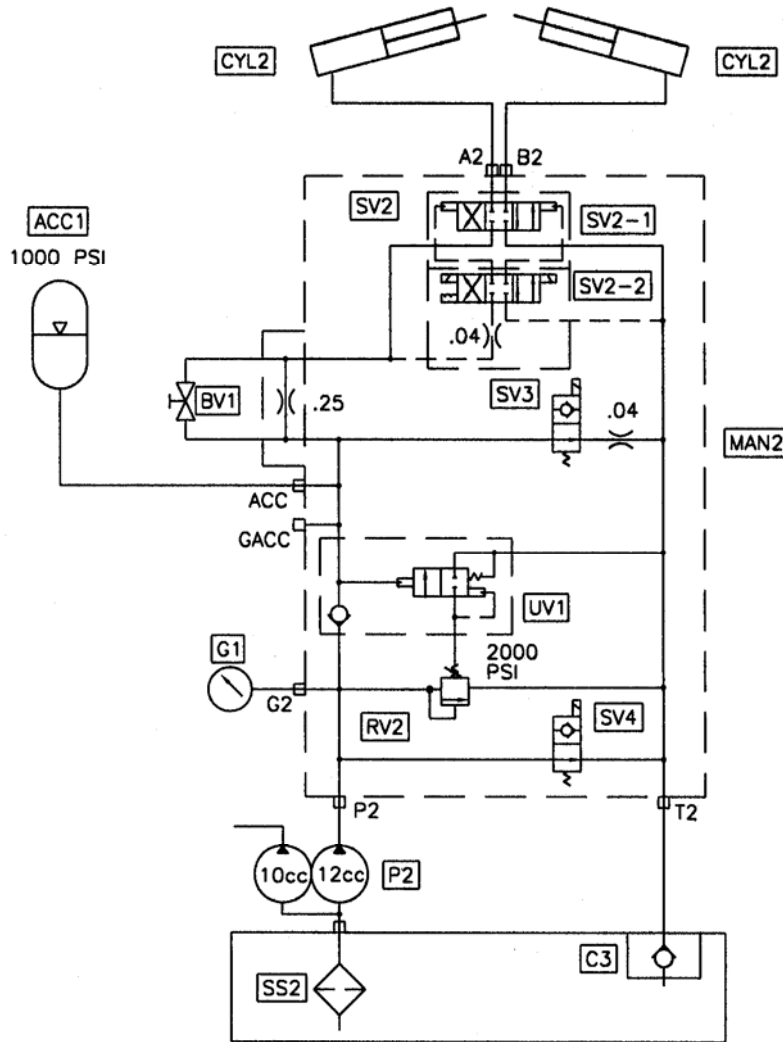

CODE	DESCRIPTION	PART NO.	QTY.
P2	Gear Pump, Parts, Group 40		
CYL2	S Tube Single Shift Cylinder	86220	2
MAN2	Manifold S Tube Circuit	85249	1
SV2	Solenoid Valve S Tube Circuit	85693	1
SV2-1	Solenoid Valve Main	85694	1
SV2-2	Solenoid Valve Pilot	85695	1
	Coil For SV2-2	85692	2
SV3	Solenoid Valve Cartridge	85699	1
	Coil For SV3	85700	1
SV4	Solenoid Valve Cartridge	85701	1
	Coil For SV4	85702	1
RV2	Relife Valve Cartrige	85703	1
UN1	Unloding Valve Cartrige	85704	1
BV1	Ball Valve	85705	1
AAC1	Accumulator	74515	1
	Accumulator, Bladder	74516	1
G2	Pressure Gauge 3000 PSI	70366	1
SS2	Magnetic Suction Strainer 1 1/4"	79247	1
C3	Check Valve	85574	1

REVISION:



**TRAILER MOUNTED PUMP 02 MODEL B50
HYDRAULIC HOSE KIT**

HOSE KIT 86365

Part No.	End #1	End #2
85666-001	Main Pump "P"	Cylinder Manifold "P1"
85666-001	Cylinder Bulkhead "A"	Cylinder "A"
85666-006	Cylinder Bulkhead "B"	Cylinder "B"
85659-001	Main pump load sense	Cylinder Manifold "LS"
85657-005	Main pump case drain	Tank return
85654-001	Cylinder Manifold "T1"	Oil Cooler "IN"
85654-001	Oil Cooler "OUT"	Return Filter Bulkhead
85659-002	Check Loop	
85659-002	Check Loop	
85659-002	Check Loop	
85659-002	Check Loop	
85659-002	Check Loop	
85663-002	Tank Suction	Tandem Pump "S"
85657-002	Tandem Pump 12cc"P"	S-Tube Manifold "P2"
85667-001	S-Tube Manifold "ACC"	Acumulator
85657-002	Bulkhead "A"	Left shift cylinder bore side
85657-002	Bulkhead "B"	Right shift cylinder bore side
85657-003	Tandem Pump 10cc"P"	Bulkhead Tee "P"
85657-002	Bulkhead Tee "P"	Bypass Valve "1"
85657-016	Bulkhead "T"	Bulkhead "P"
85657-004	Bulkhead "T"	Cylinder Manifold "T1"

SUCTION HOSES - POWER TRAIN

Part No.	End #1	End #2
85660-001	Tank Suction	Main Pump "S"
85661-001	Tank Suction	Main Pump "S"
85662-001	Tank Suction	Main Pump "S"

FUEL HOSES - 86344 FUEL GROUP

Part No.	End #1	End #2
85669-001	Fuel Tank Suction	Fuel Filter "IN"
85669-005	Fuel Filter "OUT"	Engine
74716	Engine	Fuel Tank Return

CONTROL VALVE GROUP - 86329

Part No.	End #1	End #2
85657-016	Bulkhead "P"	Agitator Valve "P"
85658-011	Agitator Valve "A"	Agitator Motor "A"
85658-010	Agitator Valve "B"	Agitator Motor "B"

HYD OUTRIGGER GROUP - 86334

Part No.	End #1	End #2
85659-010	O/R Valve "A"	RH Outrigger Bore
85659-010	O/R Valve "B"	RH Outrigger Rod
85659-010	O/R Valve Tube "A"	LH Outrigger Bore
85659-010	O/R Valve Tube "B"	LH Outrigger Rod

WATER PUMP - 86400

Part No.	End #1	End #2
85657-021	Agitator Valve "PB"	Bulkhead "P"
85657-023	Bulkhead "P"	Water Valve "P"
85657-023	Water Valve "T"	Tank
85658-002	Water Valve "B"	Motor "A"
85658-002	Water Valve "A"	Motor "B"
85657-022	Water Relief	Water Suction



**TRAILER MOUNTED PUMP 02 MODEL B50
ELECTRICAL COMPONENTS (1 OF 2)**

Code	Description	Part No.	Qty	Location
SWITCHES				
1S1	Key Switch	71154	1	Control Panel
2S2	Toggle Switch, Horn	85347	1	Control Panel
3S3	Toggle Switch, Local/Remote	78563	1	Control Panel
3S4	Toggle Switch, Pump On/Reverse	72003	1	Control Panel
3S5	Toggle Switch, Test A/B	85346	1	Control Panel
3S6	E-Stop Switch	85342	1	Control Panel
	Contact Block, 1NC for 3S6	85343	1	Control Panel
3S7	E-Stop Switch	85342	1	Remote Control
	Contact Block, 1NC for 3S7	85343	1	Remote Control
3S8	Toggle Switch, Horn	85347	1	Remote Control
3S9	Toggle Switch, Pump On/Reverse	72003	1	Remote Control
RELAYS				
1K1	Relay, Engine Start	85348	1	Engine
LIGHTS				
1L1	Light, Green, Control On	85355	1	Control Panel
1L2	Light, Red, Oil Temperature	73775	1	Control Panel
1L3	Light, Red, Coolant Level	73775	1	Control Panel
1L4	Light, Red, Oil Pressure	73775	1	Control Panel
1L5	Light, Red, Alternator	73775	1	Control Panel
	Bulb for 1L2, 1L3, 1L4, 1L5	72022	4	Control Panel
2L6	Bulb, E-Stop	85344	1	Control Panel
2L7	Light, Green, Local	85355	1	Control Panel
3L8	Light, Yellow, Remote	85356	1	Control Panel
3L9	Light, Green, Pump On	85355	1	Control Panel
3L10	Light, Green, Reverse	85355	1	Control Panel
3L11	Bulb, E-Stop	85344	1	Remote Control
3L12	Light, Green, Pump On	85355	1	Remote Control
GAUGES				
1G1	Hour Meter	74240	1	Control Panel
1G2	Tachometer	78687	1	Control Panel
1G3	Coolant Temperature Gauge	78203	1	Control Panel



**TRAILER MOUNTED PUMP 02 MODEL B50
ELECTRICAL COMPONENTS (2 OF 2)**

Code	Description	Part No.	Qty	Location
FUSES				
1F1	Fuse, 25A	800447	1	Control Panel
1F2	Fuse, 15A	90391	1	Control Panel
1F3	Fuse, 5A	90392	1	Control Panel
2F4	Fuse, 10A	800449	1	Control Panel
2F5	Fuse, 10A	800449	1	Control Panel
2F6	Fuse, 5A	90392	1	Control Panel
2F7	Fuse, 5A	90392	1	Control Panel
2F8	Fuse, 10A	800449	1	Control Panel
	Fuse Block, 8 Way	85354	1	Control Panel
SOLENOID VALVE COILS				
1Y1	Coil, Fuel Solenoid	Deutz	1	Engine
1Y2	Coil, Accumulator Bypass	85700	1	S-Tube Manifold
1Y3	Coil, S-Tube Bypass	85702	1	S-Tube Manifold
1Y4	Coil, Agitator Bypass	73184	1	Hyd. Tank
2Y5	Coil, Cylinder "B"	85692	1	S-Tube Manifold
2Y6	Coil, Cylinder "A"	85692	1	S-Tube Manifold
2Y7	Coil, S-Tube Shift "A"	85692	1	Pump Manifold
2Y8	Coil, S-Tube Shift "B"	85692	1	Pump Manifold
	Plugs for 1Y2 thru 2Y8	74597	7	Manifolds
MISCELLANEOUS				
2BB1	Black Box, Pump Control	85334	1	Control Box
2BB2	Black Box, E-Stop Logic	85596	1	Control Box
2P1	Proximity Switch, Cyl "B"	77998	1	Water Box
2P2	Proximity Switch, Cyl "A"	77998	1	Water Box
2H1	Horn	800347	1	Control Box
3R1	Resistor, 100 Ohm	72777	1	Remote Control
CONNECTORS				
X1	Connector Insert, 24 Pin, Female	78696	1	Control Box
X1	Connector Base	78697	1	Control Box
X1	Connector Insert, 24 Pin, Male	78695	1	Harness
X1	Connector Hood	800424	1	Harness
X2	Terminal Block	72820	8	Control Box
X3	Connector Insert, 10 Pin, Female	79963	1	Control Box
X3	Connector Base	79965	1	Control Box
X3	Connector Insert, 10 Pin, Male	79964	1	Remote Control
X3	Connector Hood	79966	1	Remote Control
X4	Connector, Engine, White	72926	1	Harness
X5	Connector, Engine, Yellow	76902	1	Harness

REVISION:



TRAILER MOUNTED PUMP 02 MODEL B50
CONTROL BOX
ELECTRICAL COMPONENTS

SCMTC

PAGE 09

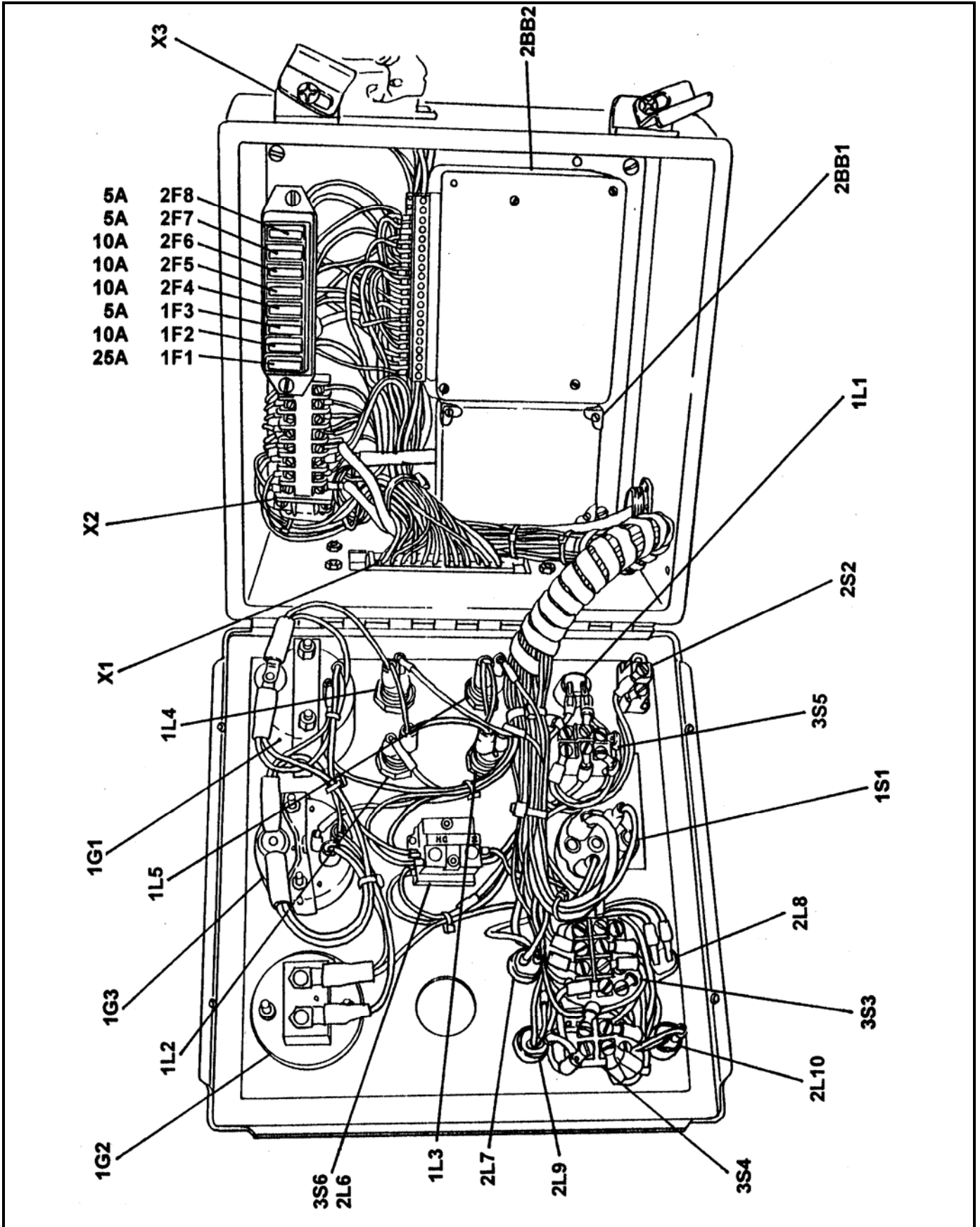

REVISION:



TRAILER MOUNTED PUMP 02 MODEL B50
CABLE REMOTE CONTROL
ELECTRICAL COMPONENTS

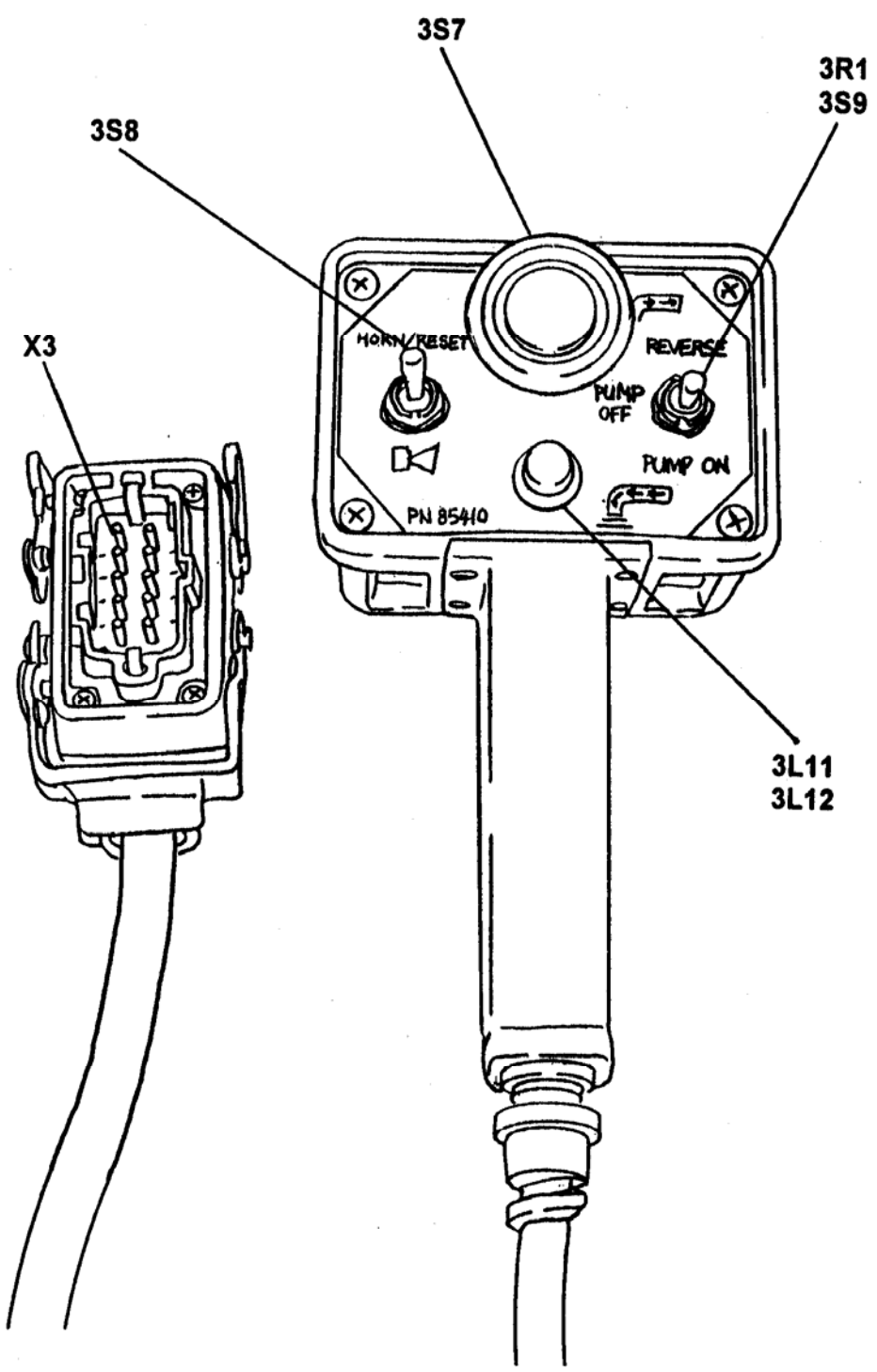



TRAILER MOUNTED PUMP 02 MODEL B50 ENGINE WIRING HARNESS

SCMTC

PAGE 11

PN 800424 HOOD
PN 78695 INSERT
PN 801479 CONNECTOR

WIRE NUMBERS
24 PIN PLUG

- 1
- 81
- 82
- 83
- 84
- 85
- 86
- 87
- 88
- 89
- 90
- 91
- 92
- 93
- 94
- 95
- 96
- 97
- 98
- 99
- 100
- 101
- 102
- 103
- 104
- 105
- 106
- 107
- 108
- 109
- 110
- 111
- 112
- 113
- 114
- 115

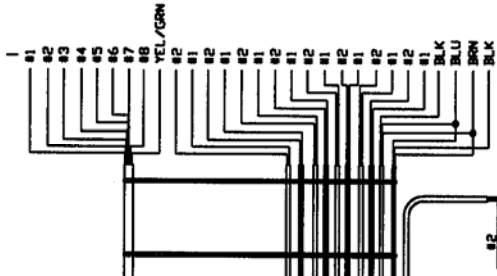

TERMINAL BLOCK

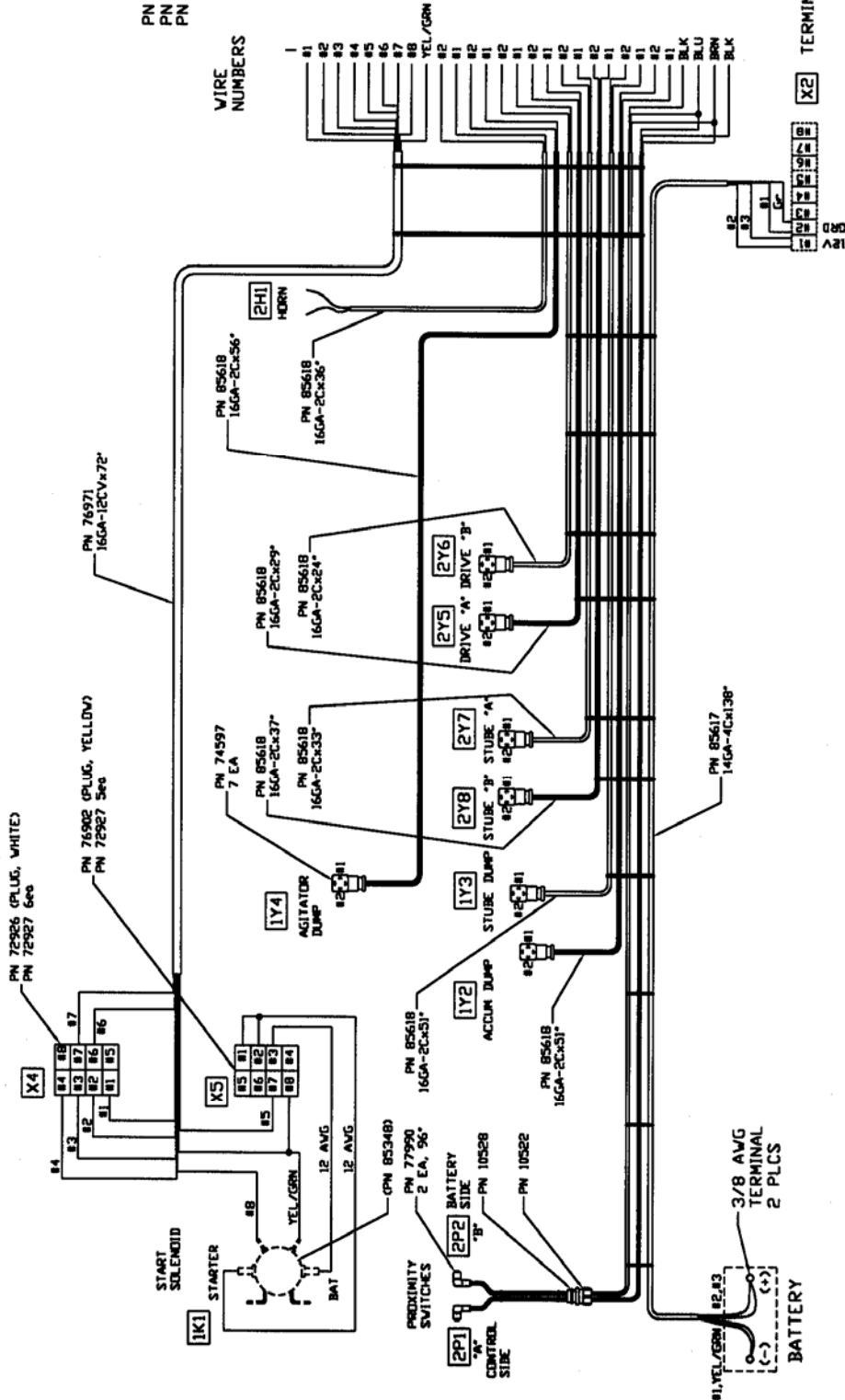
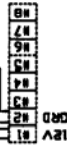

7/16/00

REVISION:



TRAILER MOUNTED PUMP 02 MODEL B50 TRAILER WIRING HARNESS

SCMTC

PAGE 12

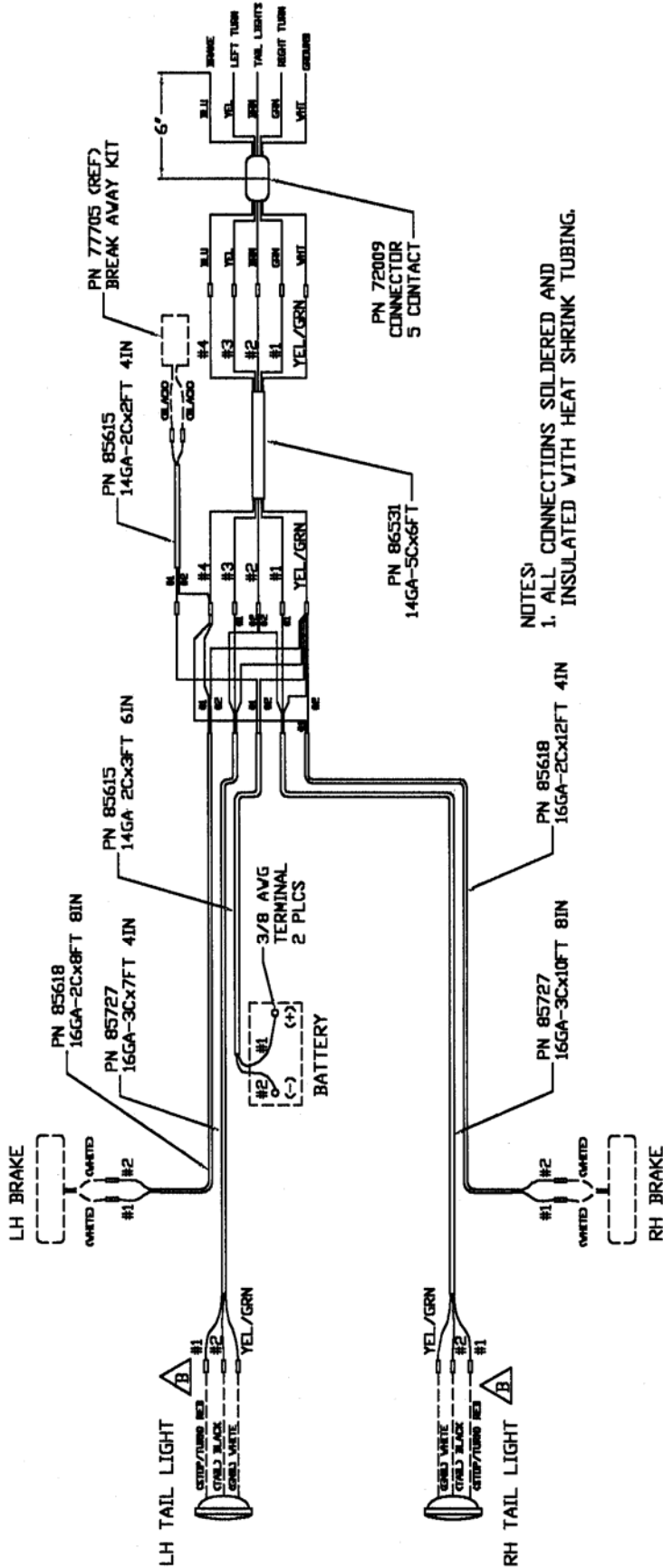

NOTES:
1. ALL CONNECTIONS SOLDERED AND INSULATED WITH HEAT SHRINK TUBING.

REED		TRAILER HARNESS		B-SERIES
		B-SERIES		SCMTC
DRAWING NO.	REV	DATE	PAGE 1 of 1	
86533	B	3/12/02		

REVISION:



TRAILER MOUNTED PUMP 02 MODEL B50
 RADIO REMOTE CONTROL OPTION
 ELECTRICAL SCHEMATIC

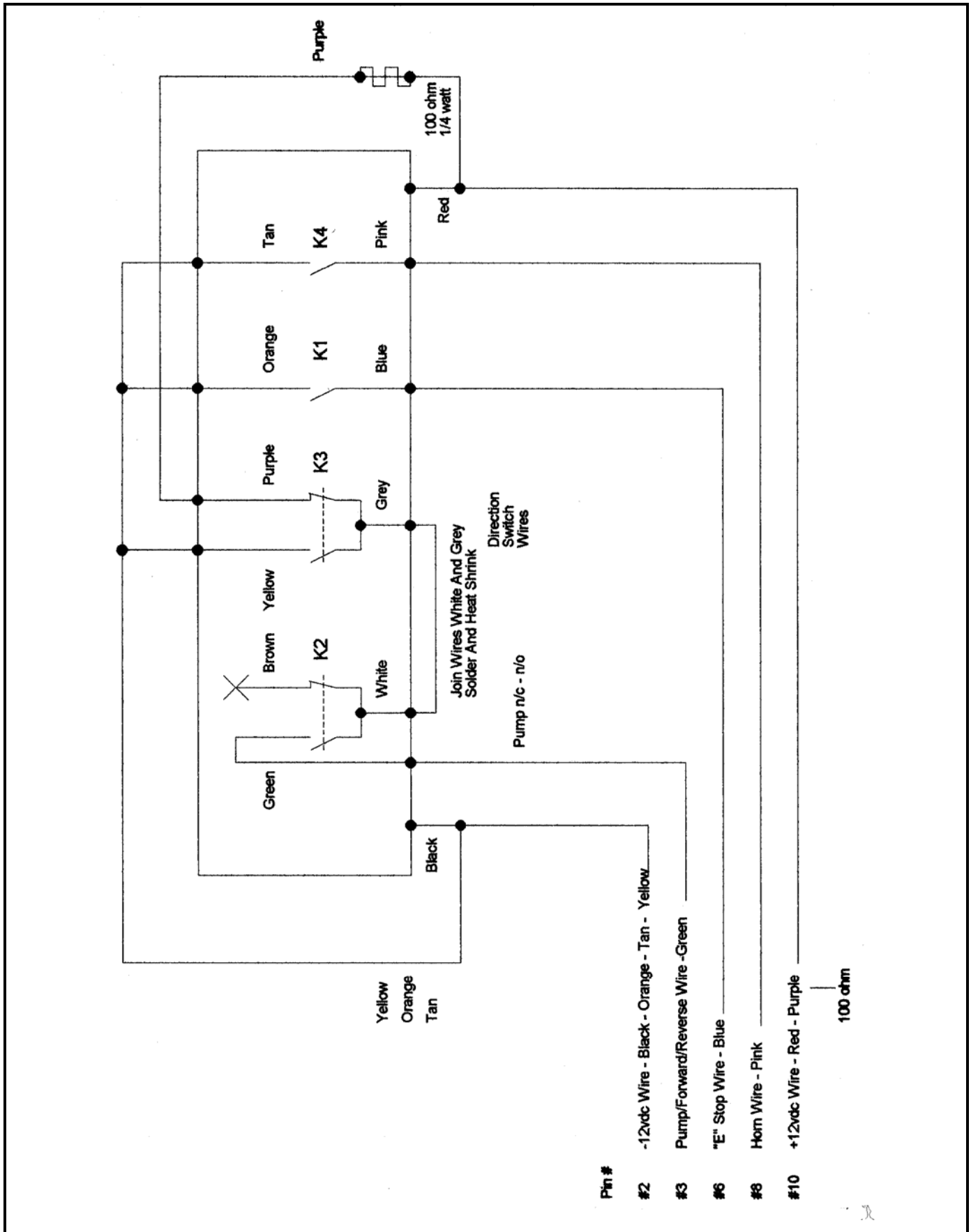

REVISION:



TRAILER MOUNTED PUMP 02 MODEL B50
 RADIO REMOTE CONTROL OPTION
 WIRING DIAGRAM

OPER.

PAGE 14

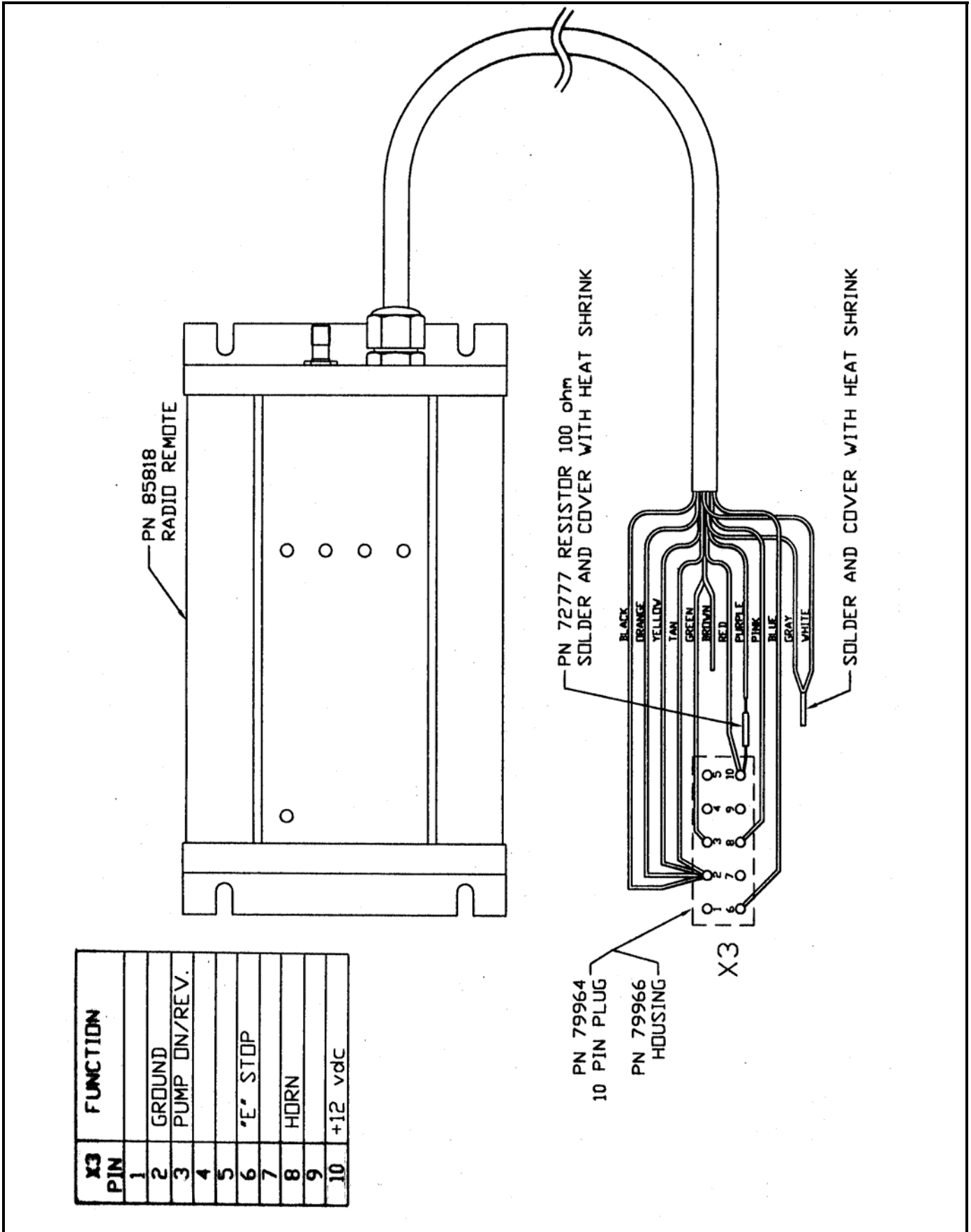

X3 PIN	FUNCTION
1	
2	GROUND
3	PUMP ON/REV.
4	
5	
6	'E' STOP
7	
8	HORN
9	
10	+12 vdc

REVISION:



TRAILER MOUNTED PUMP 02 MODEL B50
HOPPER VIBRATOR OPTION
ELECTRICAL SCHEMATIC

OPER.

PAGE 15

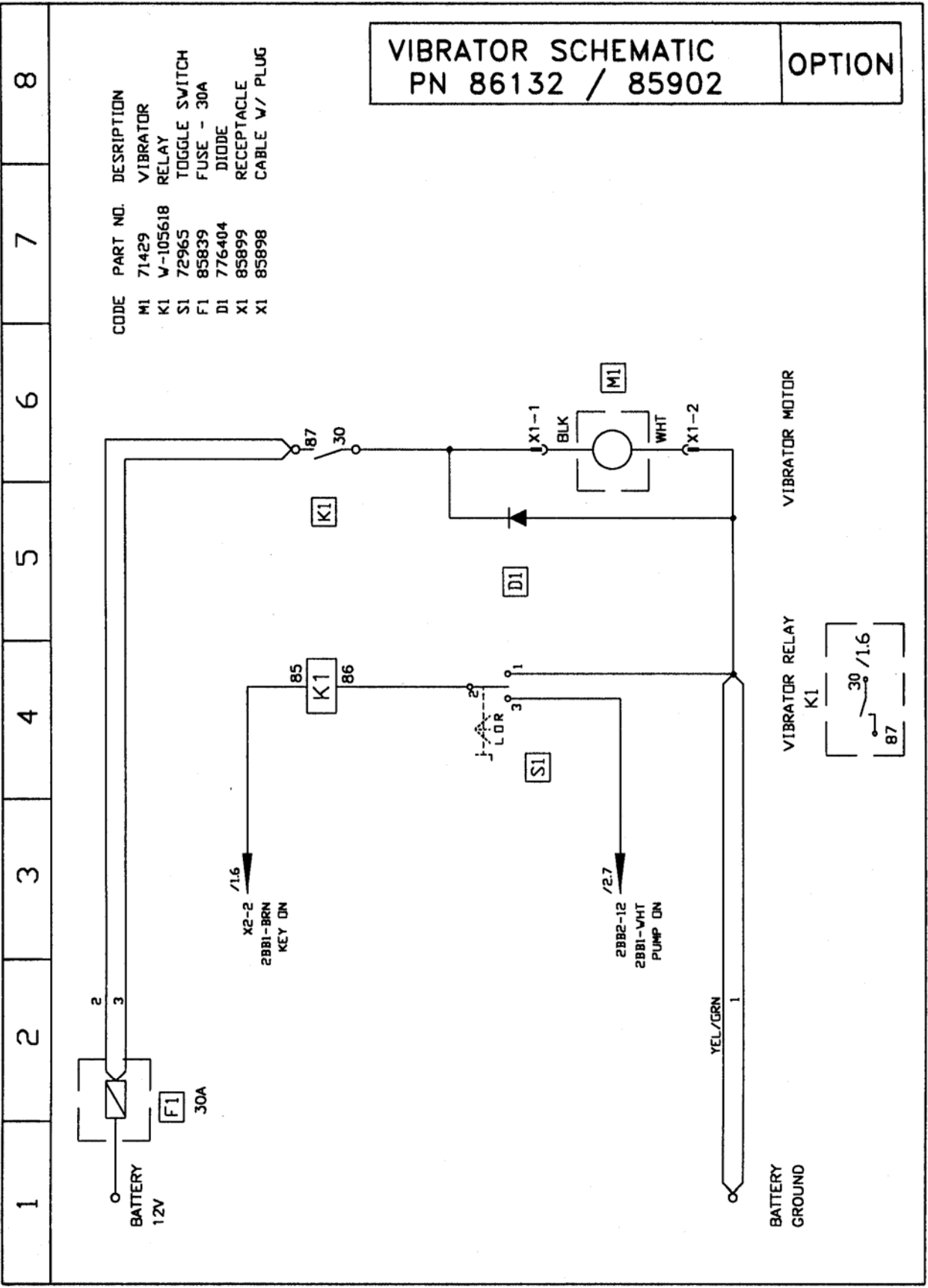

REVISION:



TRAILER MOUNTED PUMP 02 MODEL B50
STROKE COUNTER OPTION
ELECTRICAL SCHEMATIC

OPER.

PAGE 17

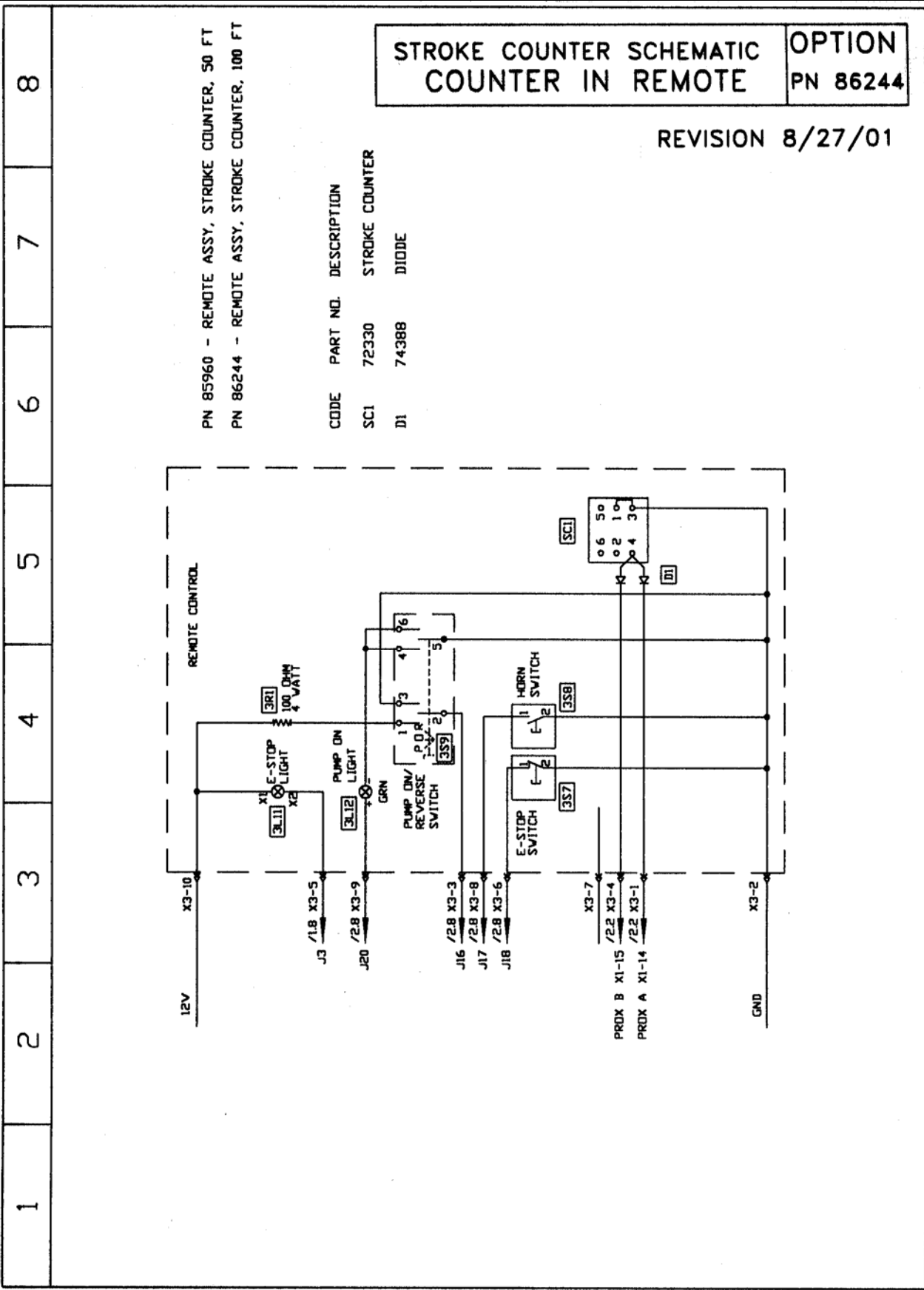

REVISION:

1 2 3

PN 85358 CONTROL BOX

PN 85359 REMOTE CONTROL

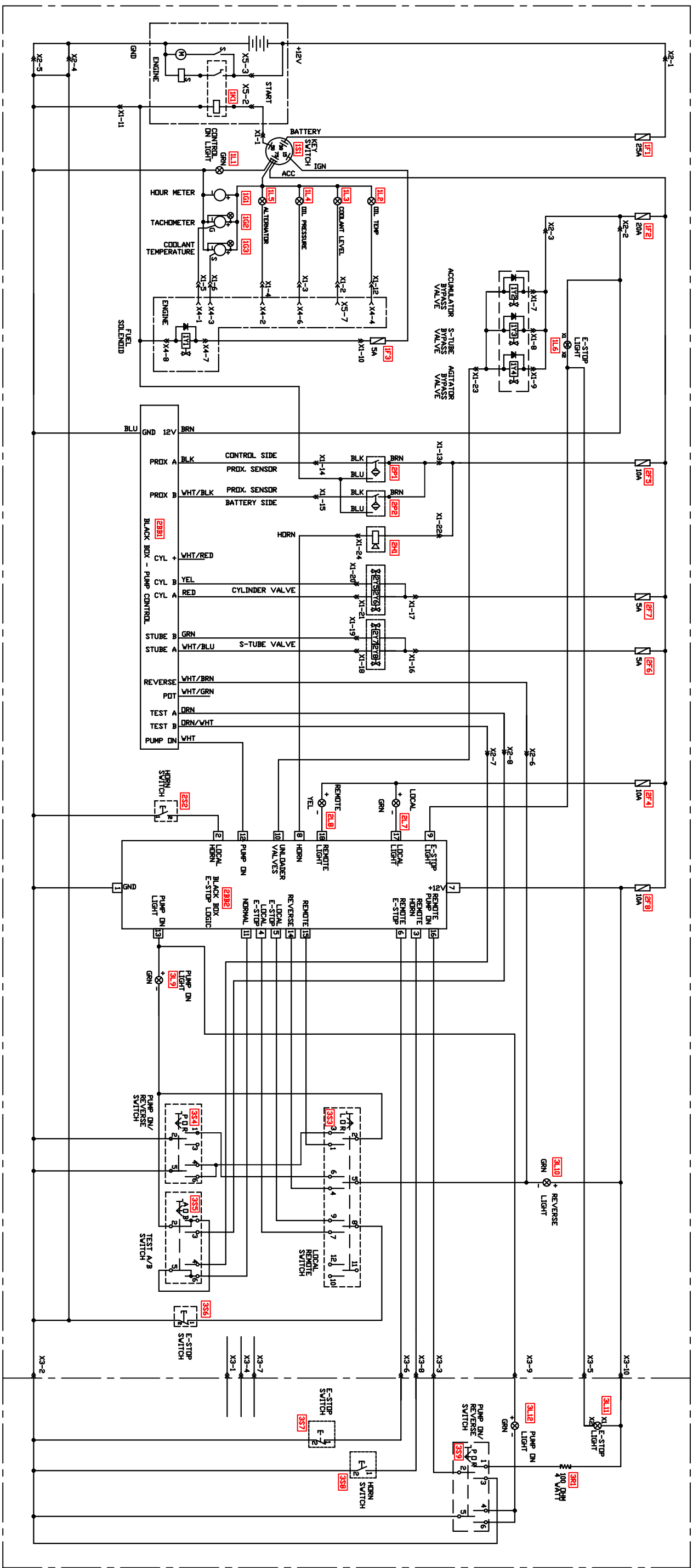

REED		ELECTRICAL SCHEMATIC		B-SERIES	
DRAWING NO.	REV	DATE	SCMTC	PAGE 1 OF 1	
86625	C	7/3/01	B-SERIES		