



**TRAILER MTD. PUMP 03 MODEL B20
DRIVE CYLINDER CIRCUIT
HYDRAULIC COMPONENTS & SCHEMATIC**

B20HP DRIVE CYLINDER CIRCUIT
HYDRAULIC SCHEMATIC

DATE
3/22/04

REV.

PART NO.
86708

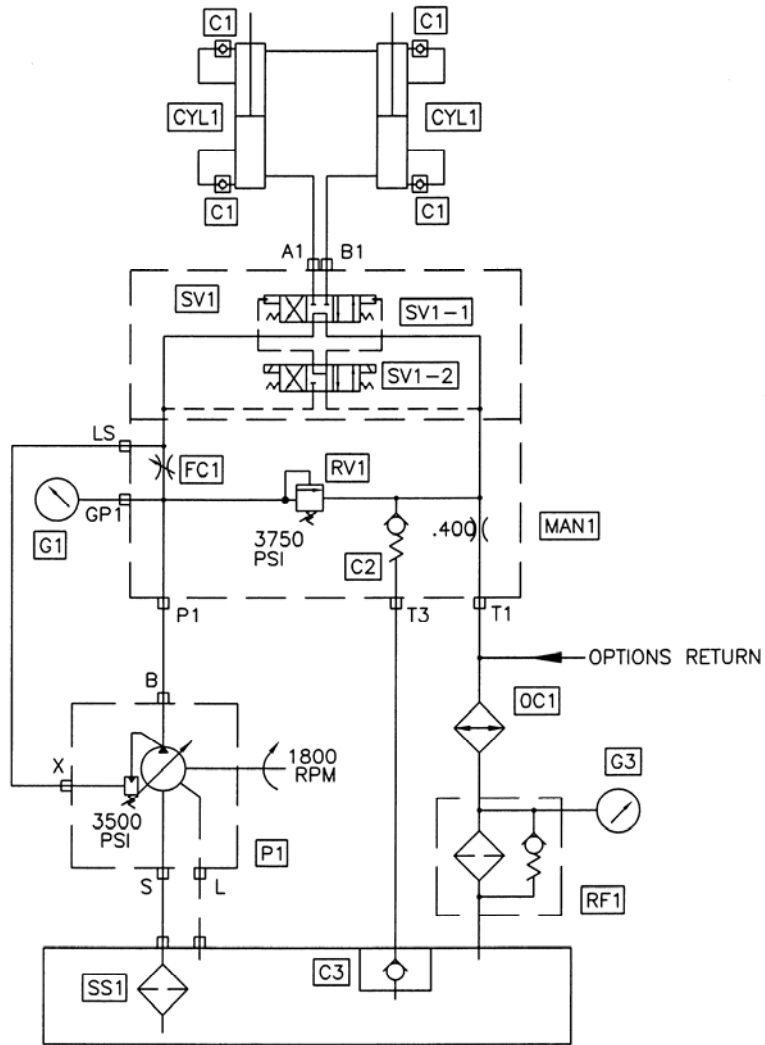

CODE	DESCRIPTION	PART NO.	QTY.
P1	Main Pump, Parts, Group 40		
CYL1	Hydraulic Drive Cylinder, Parts Group 60		
MAN1	Manifold Drive Cylinder Circuit	85248	1
SV1	Solenoid Valve, Drive Cylinder Circuit	85689	1
SV1-1	Solenoid Valve Main	85690	1
SV2-2	Solenoid Valve Pilot	85691	1
	Coil For SV2-2	85692	2
RV1	Relief Valve Cartridge	85696	1
FC1	Flow Control Valve Cartridge	85697	1
C1	Check Valve	78961	4
C2	Check Valve Cartridge	85698	1
C3	Check Valve	85574	1
G1	Pressure Gauge 6000 psi	74562	1
G3	Pressure Gauge Return	85575	1
OC1	Oil Cooler	79433	1
RF1	Return Filter	85282	1
	Return Filter Element	85283	1
SS1	Magnetic Suction Strainer 2"	801024	1



**TRAILER MTD. PUMP 03 MODEL B20
DUAL SHIFT SWING TUBE CIRCUIT
HYDRAULIC COMPONENTS & SCHEMATIC**

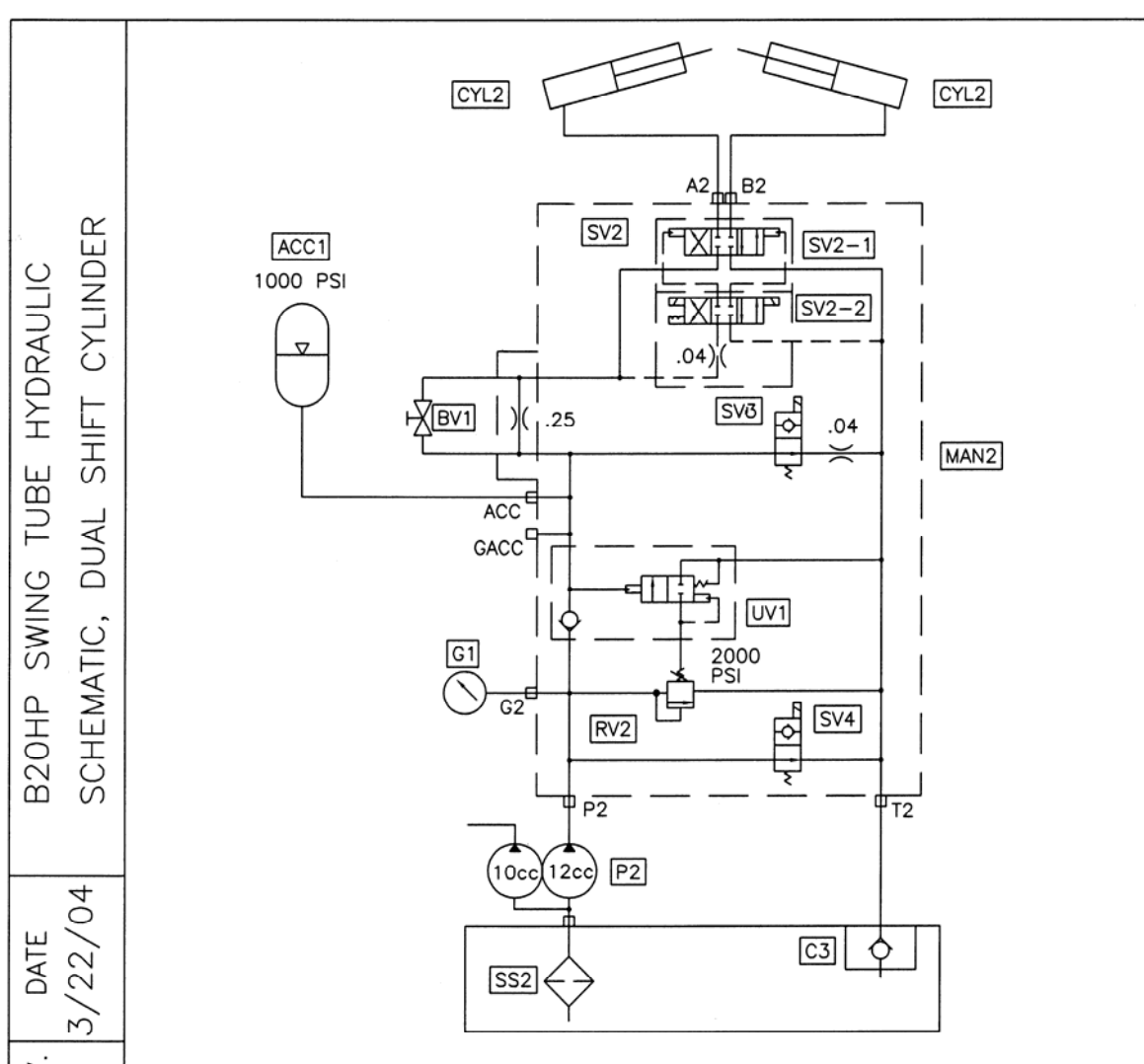

REV.	DATE	DESCRIPTION	PART NO.	QTY.
	3/22/04	B20HP SWING TUBE HYDRAULIC SCHEMATIC, DUAL SHIFT CYLINDER		
		P2	Gear Pump, Parts, Group 40	
		CYL2	S Tube Dual Shift Cylinder	2
		MAN2	Manifold S Tube Circuit	1
		SV2	Solenoid Valve S Tube Circuit	1
		SV2-1	Solenoid Valve Main	1
		SV2-2	Solenoid Valve Pilot	1
			Coil For SV2-2	2
		SV3	Solenoid Valve Cartridge	1
			Coil For SV3	1
		SV4	Solenoid Valve Cartridge	1
			Coil For SV4	1
		RV2	Relief Valve Cartridge	1
		UN1	Unloading Valve Cartridge	1
		BV1	Ball Valve	1
		AAC1	Accumulator	1
			Accumulator-Mtg Bracket	1
		G2	Pressure Gauge 3000 PSI	1
		SS2	Magnetic Suction Strainer 1 1/4"	1
		C3	Check Valve	1

REVISION:



**TRAILER MTD. PUMP 03 MODEL B20
HYDRAULIC HOSE KIT**

HOSE KIT 86365

Part No.	End #1	End #2
85666-001	Main Pump "P"	Cylinder Manifold "P1"
85666-001	Cylinder Bulkhead "A"	Cylinder "A"
85666-006	Cylinder Bulkhead "B"	Cylinder "B"
85659-001	Main pump load sense	Cylinder Manifold "LS"
85657-005	Main pump case drain	Tank return
85654-001	Cylinder Manifold "T1"	Oil Cooler "IN"
85654-001	Oil Cooler "OUT"	Return Filter Bulkhead
85659-002	Check Loop	
85659-002	Check Loop	
85659-002	Check Loop	
85659-002	Check Loop	
85659-002	Check Loop	
85663-002	Tank Suction	Tandem Pump "S"
85657-002	Tandem Pump 12cc"P"	S-Tube Manifold "P2"
85667-001	S-Tube Manifold "ACC"	Acumulator
85657-002	Bulkhead "A"	Left shift cylinder bore side
85657-002	Bulkhead "B"	Right shift cylinder bore side
85657-003	Tandem Pump 10cc"P"	Bulkhead Tee "P"
85657-002	Bulkhead Tee "P"	Bypass Valve "1"
85657-016	Bulkhead "T"	Bulkhead "P"
85657-004	Bulkhead "T"	Cylinder Manifold "T1"

SUCTION HOSES - POWER TRAIN

Part No.	End #1	End #2
85660-001	Tank Suction	Main Pump "S"
85661-001	Tank Suction	Main Pump "S"
85662-001	Tank Suction	Main Pump "S"

FUEL HOSES - 86344 FUEL GROUP

Part No.	End #1	End #2
85669-001	Fuel Tank Suction	Fuel Filter "IN"
85669-005	Fuel Filter "OUT"	Engine
74716	Engine	Fuel Tank Return

CONTROL VALVE GROUP - 86329

Part No.	End #1	End #2
85657-016	Bulkhead "P"	Agitator Valve "P"
85658-011	Agitator Valve "A"	Agitator Motor "A"
85658-010	Agitator Valve "B"	Agitator Motor "B"

HYD OUTRIGGER GROUP - 86334

Part No.	End #1	End #2
85659-010	O/R Valve "A"	RH Outrigger Bore
85659-010	O/R Valve "B"	RH Outrigger Rod
85659-010	O/R Valve Tube "A"	LH Outrigger Bore
85659-010	O/R Valve Tube "B"	LH Outrigger Rod

WATER PUMP - 86400

Part No.	End #1	End #2
85657-021	Agitator Valve "PB"	Bulkhead "P"
85657-023	Bulkhead "P"	Water Valve "P"
85657-023	Water Valve "T"	Tank
85658-002	Water Valve "B"	Motor "A"
85658-002	Water Valve "A"	Motor "B"
85657-022	Water Relief	Water Suction

REVISION:



**TRAILER MTD. PUMP 03 MODEL B20
ELECTRICAL COMPONENTS (1 OF 2)**

Code	Description	Part No.	Qty	Location
SWITCHES				
1S1	Key Switch	71154	1	Control Panel
2S2	Toggle Switch, Horn	85347	1	Control Panel
3S3	Toggle Switch, Local/Remote	78563	1	Control Panel
3S4	Toggle Switch, Pump On/Reverse	72003	1	Control Panel
3S5	Toggle Switch, Test A/B	85346	1	Control Panel
3S6	E-Stop Switch	85342	1	Control Panel
	Contact Block, 1NC for 3S6	85343	1	Control Panel
3S7	E-Stop Switch	85342	1	Remote Control
	Contact Block, 1NC for 3S7	85343	1	Remote Control
3S8	Toggle Switch, Horn	85347	1	Remote Control
3S9	Toggle Switch, Pump On/Reverse	72003	1	Remote Control
LIGHTS				
1L1	Light, Green, Control On	85355	1	Control Panel
2L6	Bulb, E-Stop	85344	1	Control Panel
2L7	Light, Green, Local	85355	1	Control Panel
3L8	Light, Yellow, Remote	85356	1	Control Panel
3L9	Light, Green, Pump On	85355	1	Control Panel
3L10	Light, Green, Reverse	85355	1	Control Panel
3L11	Bulb, E-Stop	85344	1	Remote Control
3L12	Light, Green, Pump On	85355	1	Remote Control
GAUGES				
1G1	Hour Meter	74240	1	Control Panel
FUSES				
1F1	Fuse, 25A	800447	1	Control Panel
1F2	Fuse, 20A	800448	1	Control Panel
2F4	Fuse, 10A	800449	1	Control Panel
2F5	Fuse, 10A	800449	1	Control Panel
2F6	Fuse, 5A	90392	1	Control Panel
2F7	Fuse, 5A	90392	1	Control Panel
2F8	Fuse, 10A	800449	1	Control Panel
	Fuse Block, 8 Way	85354	1	Control Panel

REVISION:



**TRAILER MTD. PUMP 03 MODEL B20
ELECTRICAL COMPONENTS (2 OF 2)**

Code	Description	Part No.	Qty	Location
SOLENOID VALVE COILS				
1Y2	Coil, Accumulator Bypass	85700	1	S-Tube Manifold
1Y3	Coil, S-Tube Bypass	85702	1	S-Tube Manifold
1Y4	Coil, Agitator Bypass	73184	1	Hyd. Tank
2Y5	Coil, Cylinder "B"	85692	1	S-Tube Manifold
2Y6	Coil, Cylinder "A"	85692	1	S-Tube Manifold
2Y7	Coil, S-Tube Shift "A"	85692	1	Pump Manifold
2Y8	Coil, S-Tube Shift "B"	85692	1	Pump Manifold
	Plugs for 1Y2 thru 2Y8	74597	7	Manifolds
MISCELLANEOUS				
2BB1	Black Box, Pump Control	85334	1	Control Box
2BB2	Black Box, E-Stop Logic	85596	1	Control Box
2P1	Proximity Switch, Cyl "B"	77998	1	Water Box
2P2	Proximity Switch, Cyl "A"	77998	1	Water Box
2H1	Horn	800347	1	Control Box
3R1	Resistor, 100 Ohm	72777	1	Remote Control
1M1	Oil Cooler	79433	1	Hood
CONNECTORS				
X1	Connector Insert, 24 Pin, Female	78696	1	Control Box
X1	Connector Base	78697	1	Control Box
X1	Connector Insert, 24 Pin, Male	78695	1	Harness
X1	Connector Hood	800424	1	Harness
X2	Terminal Block	72820	8	Control Box
X3	Connector Insert, 10 Pin, Female	79963	1	Control Box
X3	Connector Base	79965	1	Control Box
X3	Connector Insert, 10 Pin, Male	79964	1	Remote Control
X3	Connector Hood	79966	1	Remote Control

REVISION:



TRAILER MTD. PUMP 03 MODEL B20 ENGINE WIRING HARNESS

SCMTC

PAGE 07

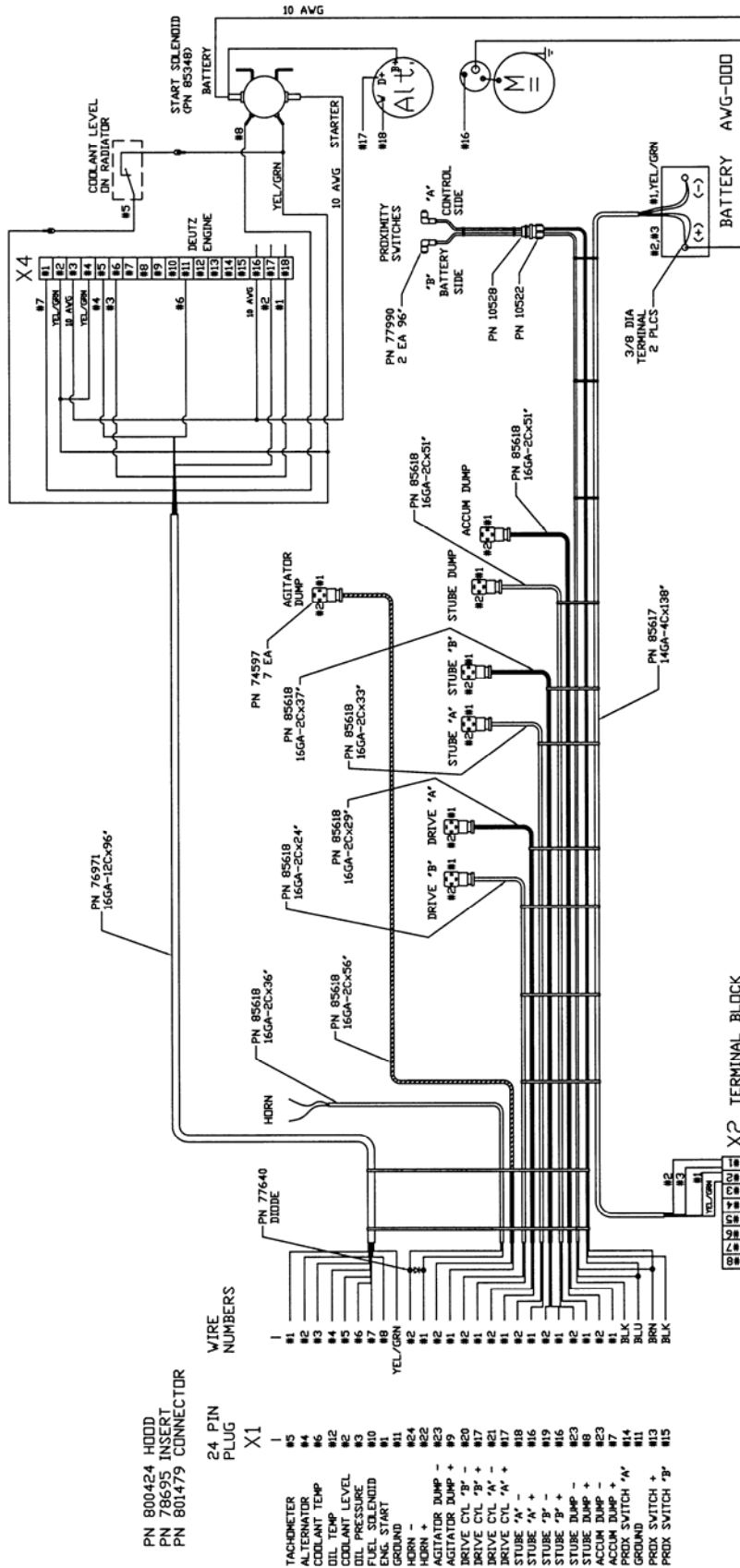

REF-REED DRAWING No. 87194

REVISION:



**TRAILER MTD. PUMP 03 MODEL B20
ELECTRICAL SCHEMATIC**

SCMTC

PAGE 08

**INSERT SIZE 11X 17
ELECTRICAL SCHEMATIC -HERE**

REVISION:



TRAILER MTD. PUMP 03 MODEL B20 CONTROL BOX ELECTRICAL COMPONENTS

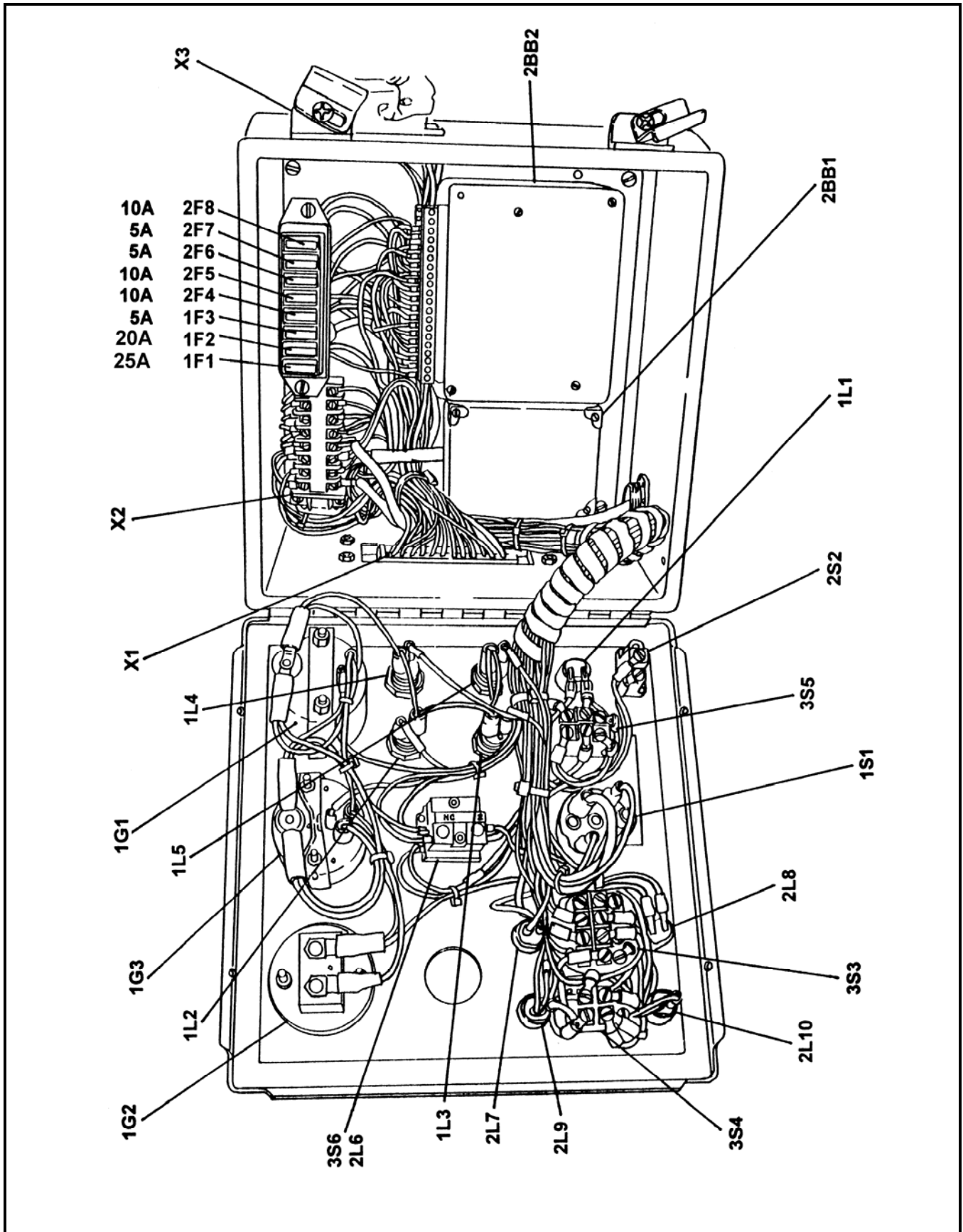

REVISION:



TRAILER MTD. PUMP 03 MODEL B20
CABLE REMOTE CONTROL
ELECTRICAL COMPONENTS

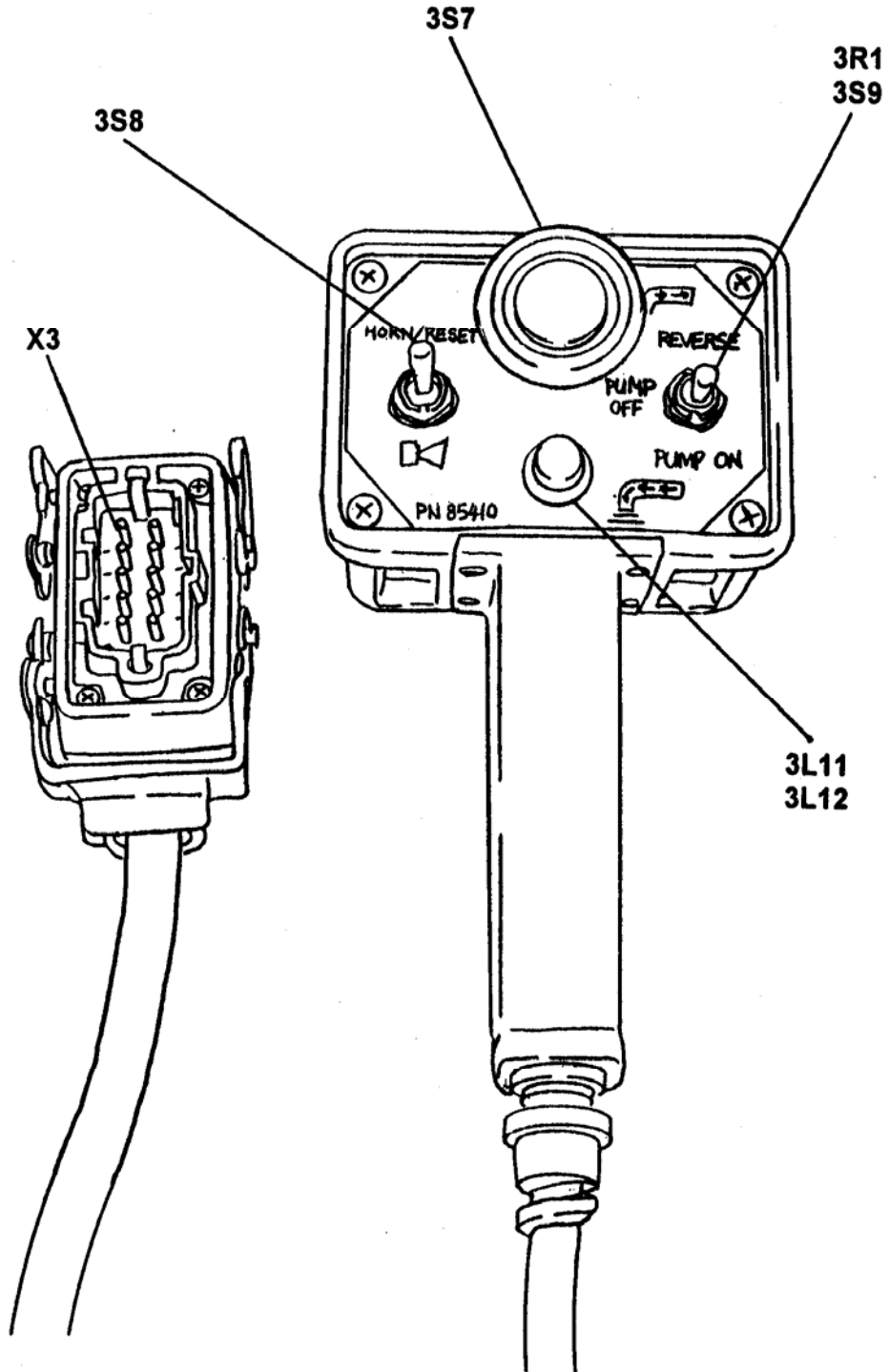



TRAILER MTD. PUMP 03 MODEL B20
 RADIO REMOTE CONTROL OPTION
 ELECTRICAL SCHEMATIC

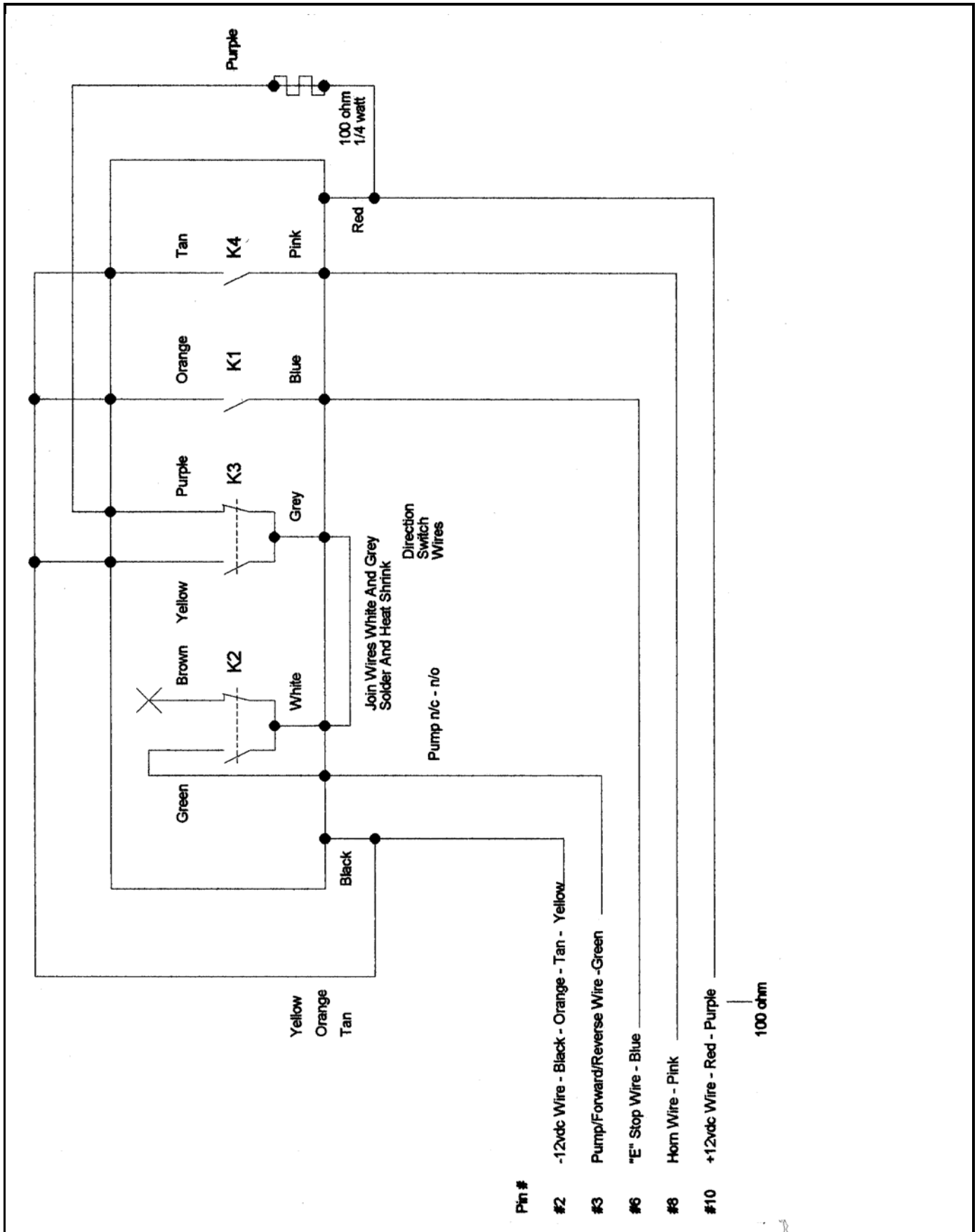

REVISION:



TRAILER MTD. PUMP 03 MODEL B20
 RADIO REMOTE CONTROL OPTION
 WIRING DIAGRAM

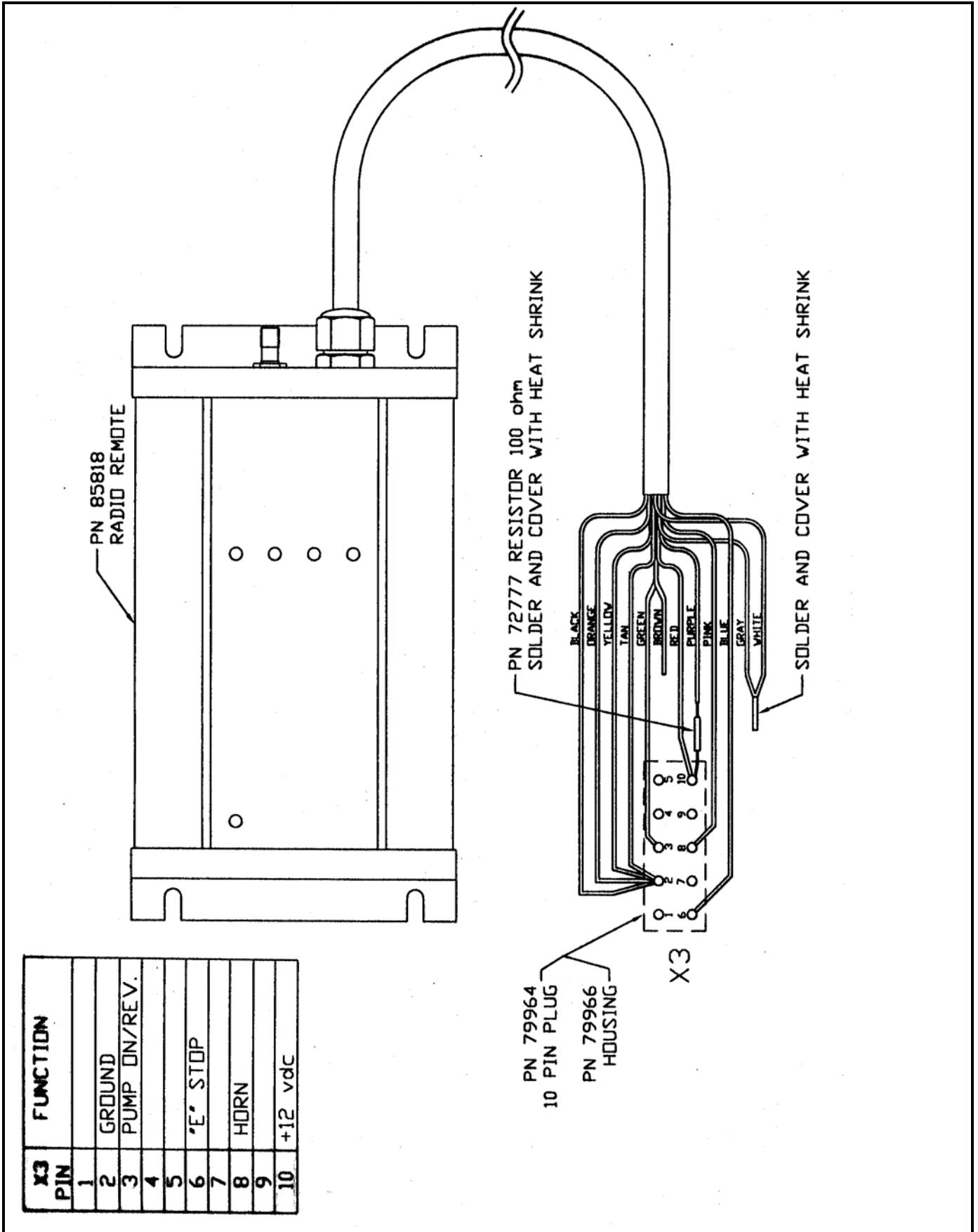

X3 PIN	FUNCTION
1	
2	GROUND
3	PUMP ON/REV.
4	
5	
6	'E' STOP
7	
8	HORN
9	
10	+12 vdc

REVISION:



TRAILER MTD. PUMP 03 MODEL B20
 RADIO REMOTE CONTROL OPTION
 ELECTRICAL SCHEMATIC

SCMTC

PAGE 13

1 2 3 4 5 6 7 8

CODE	PART NO.	DESCRIPTION
M1	71429	VIBRATOR
K1	W-105618	RELAY
S1	72965	TOGGLE SWITCH
F1	85839	FUSE - 30A
D1	776404	DIODE
X1	85899	RECEPTACLE
X1	85898	CABLE W/ PLUG

VIBRATOR SCHEMATIC
 PN 86132 / 85902
 OPTION

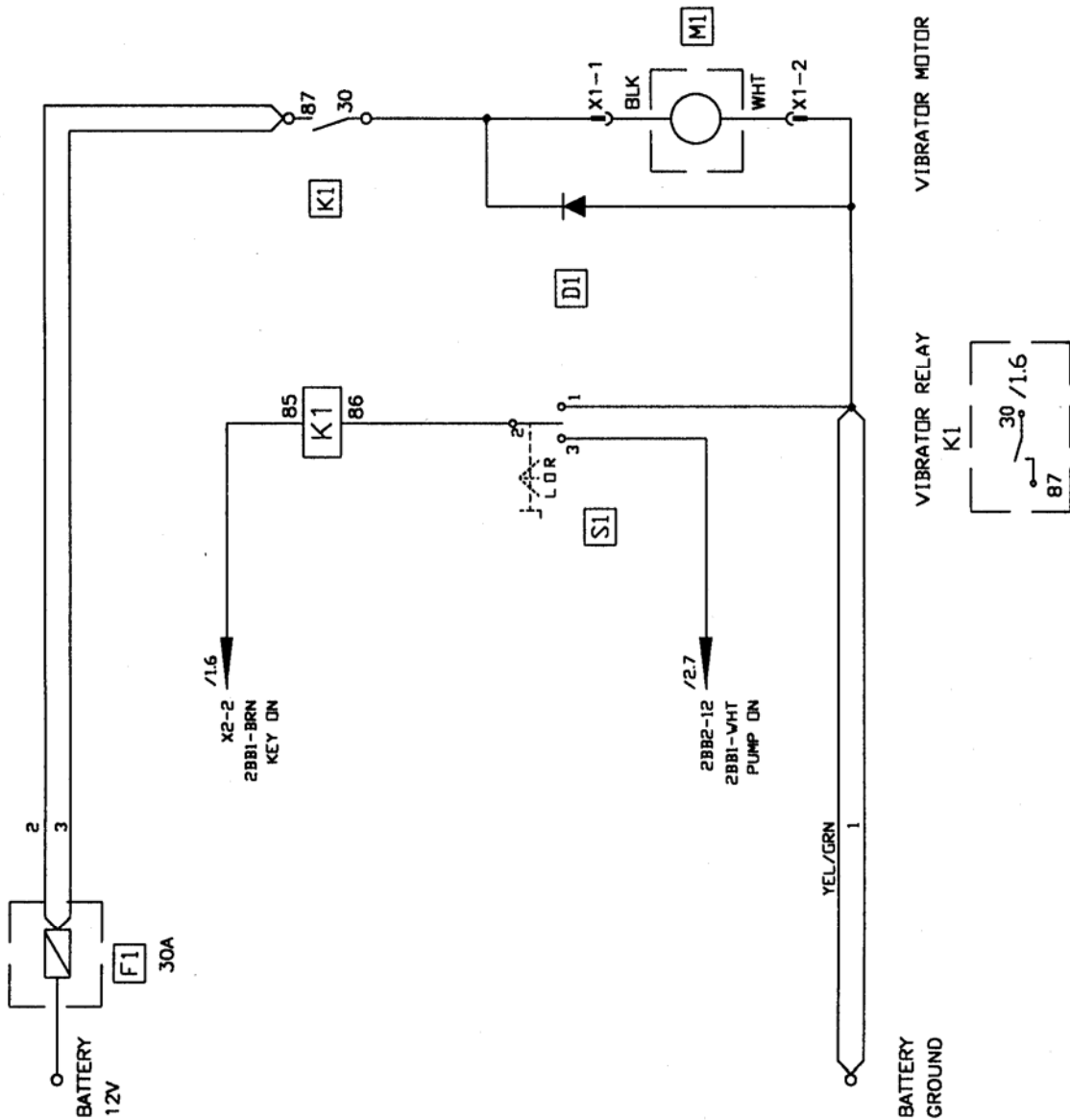

REVISION:



TRAILER MTD. PUMP 03 MODEL B20 STROKE COUNTER OPTION ELECTRICAL SCHEMATIC

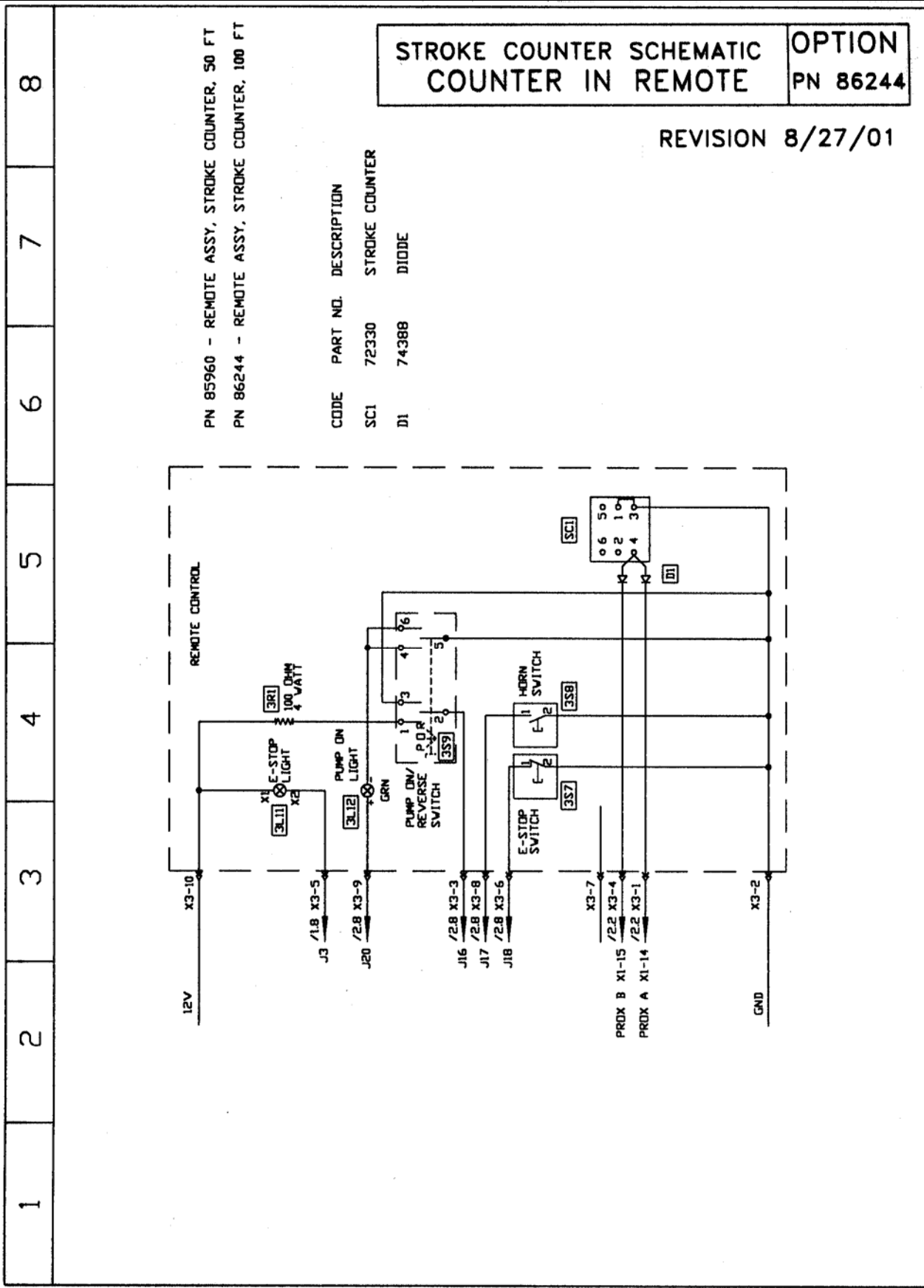

REVISION:



**TRAILER MTD. PUMP 03 MODEL B20
SINGLE SHIFT SWING TUBE CIRCUIT
HYDRAULIC COMPONENTS & SCHEMATIC**

B & C SERIES SWING TUBE HYDRAULIC
SCHEMATIC, SINGLE SHIFT CYLINDER

DATE
11/7/01

REV.
PART NO.
86705

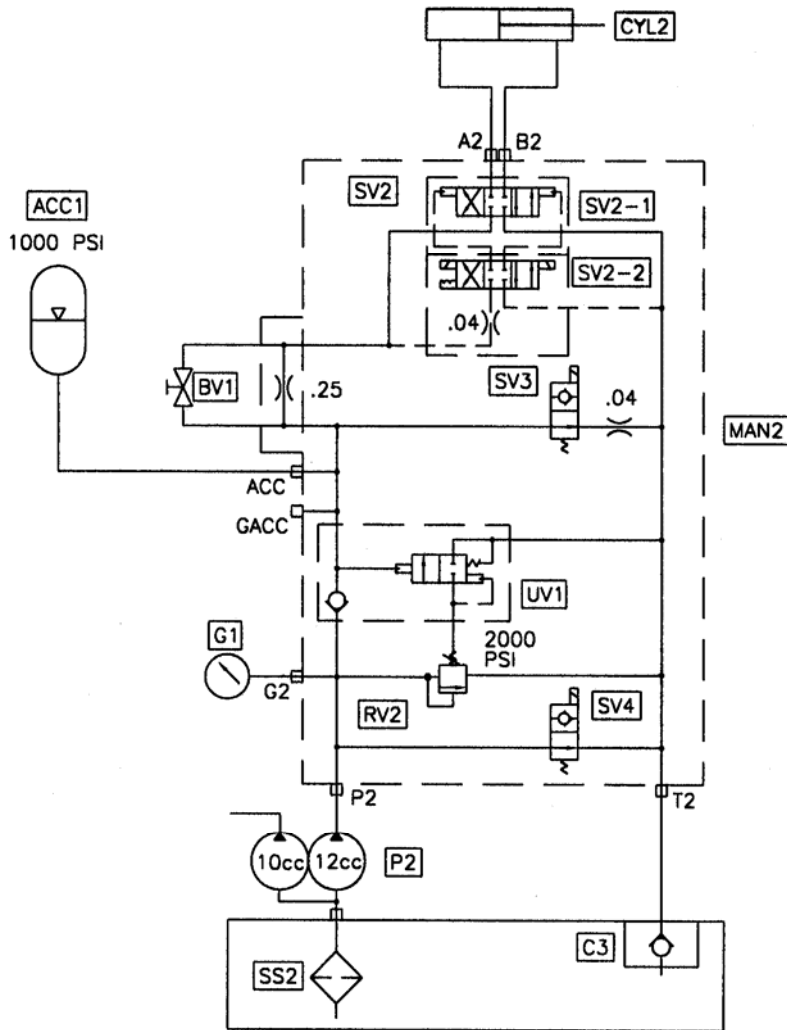

CODE	DESCRIPTION	PART NO.	QTY.
P2	Gear Pump, Parts, Group 40	73156	1
CYL2	S Tube Single Shift Cylinder	86221	1
MAN2	Manifold S Tube Circuit	85249	1
SV2	Solenoid Valve S Tube Circuit	85693	1
SV2-1	Solenoid Valve Main	85694	1
SV2-2	Solenoid Valve Pilot	85695	1
	Coil For SV2-2	85692	2
SV3	Solenoid Valve Cartridge	85699	1
	Coil For SV3	85700	1
SV4	Solenoid Valve Cartridge	85701	1
	Coil For SV4	85702	1
RV2	Relife Valve Cartrige	85703	1
UN1	Unlodng Valve Cartrige	85704	1
BV1	Ball Valve	85705	1
AAC1	Accumulator	74515	1
	Accumulator, Bladder	74516	1
G2	Pressure Gauge 3000 PSI	70366	1
SS2	Magnetic Suction Strainer 1 1/4"	79247	1
C3	Check Valve	85574	1

REVISION: