

PN 85358 CONTROL BOX

REMOTE CONTROL

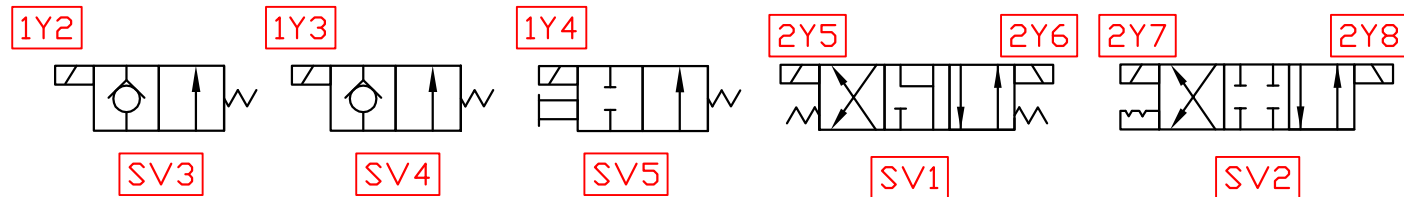
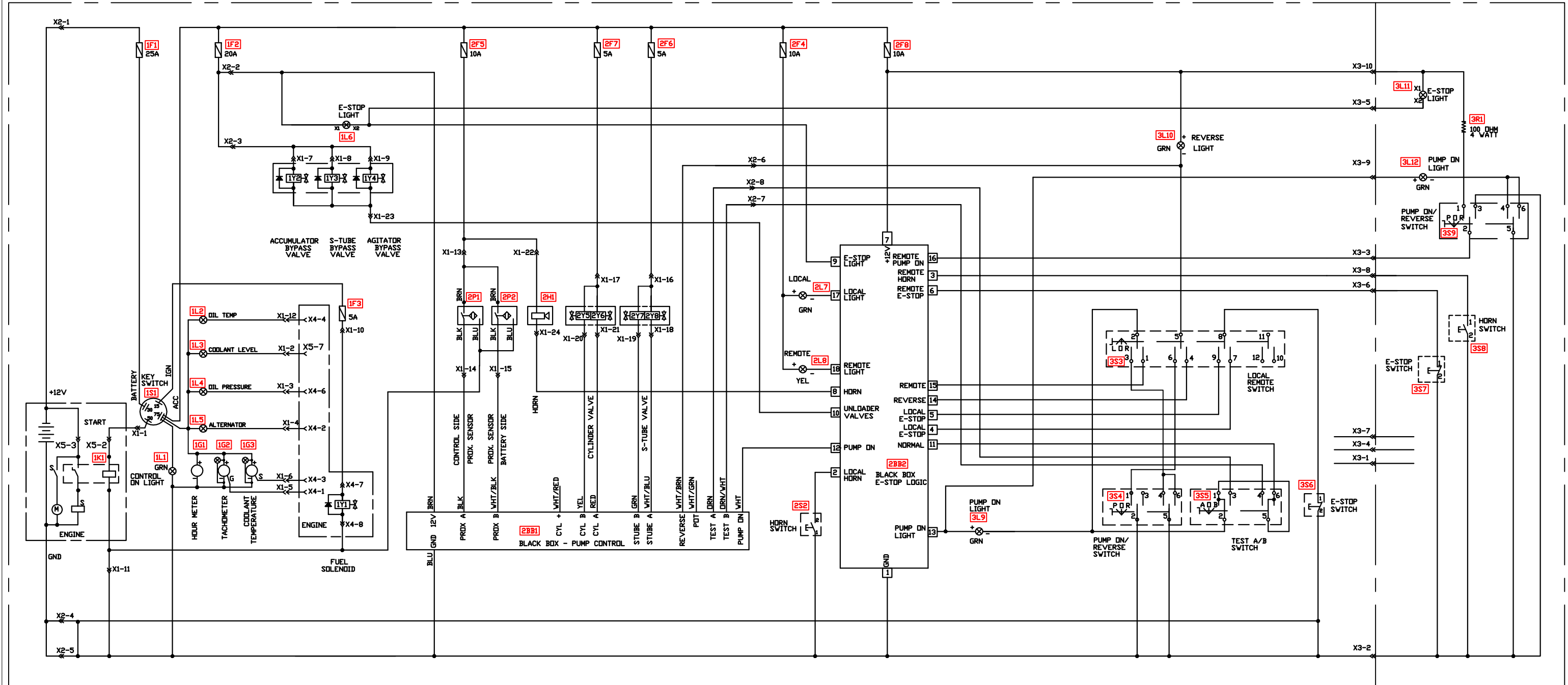

REED		
DRAWING NO. 86625	REV C	DATE 10/12/01

ELECTRICAL SCHEMATIC
B-SERIES

B-SERIES
SCMTC
PAGE10F1

PN 85358 CONTROL BOX

REMOTE CONTROL

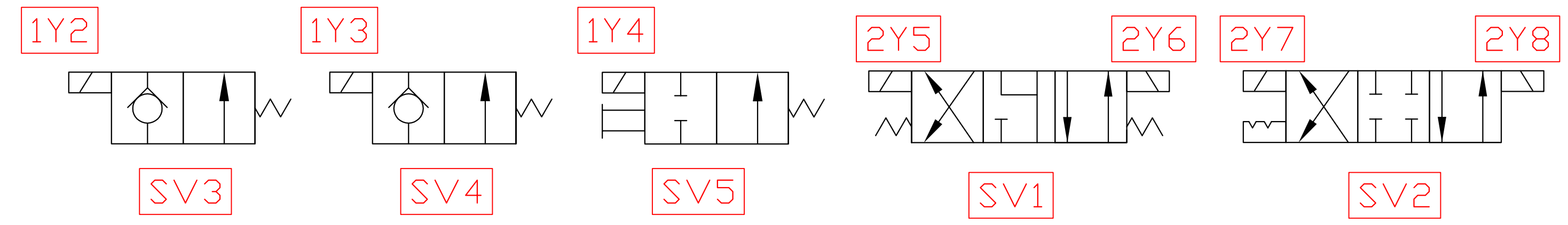
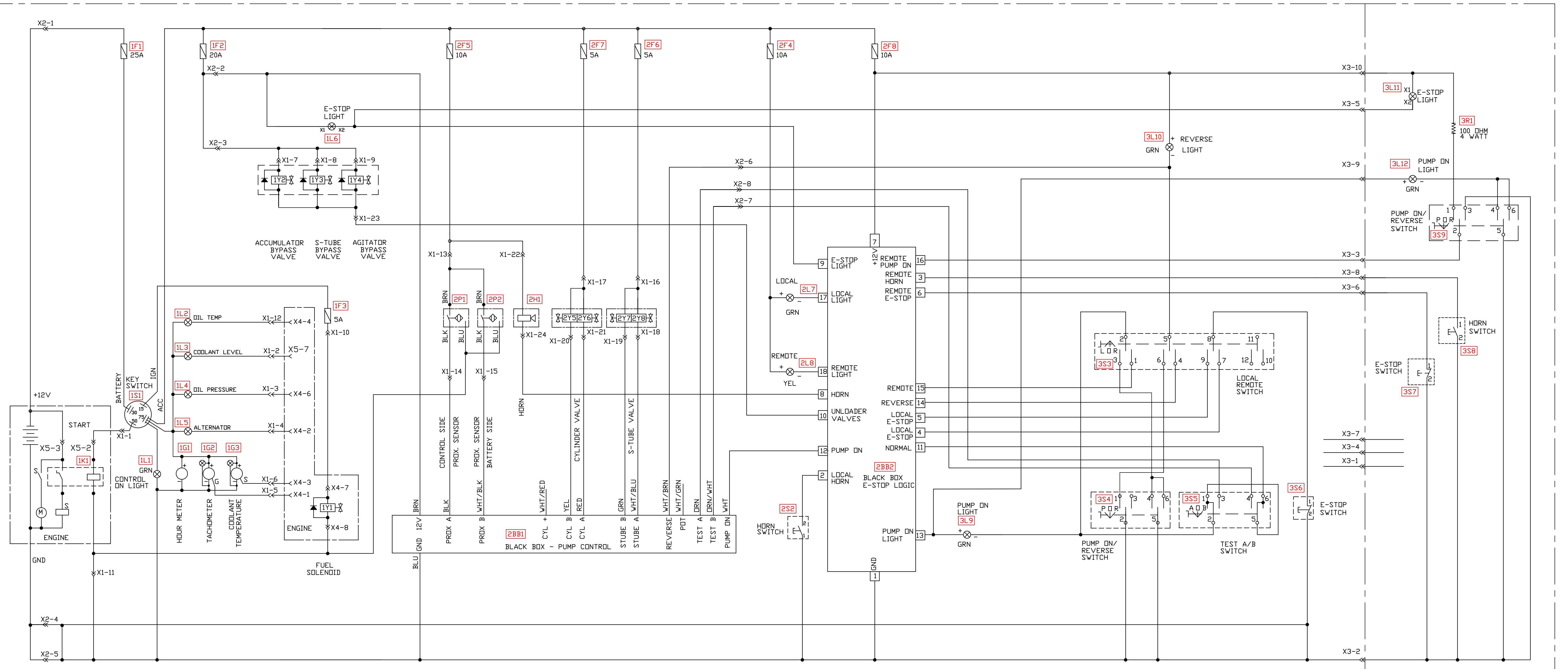

REED

ELECTRICAL SCHEMATIC B-SERIES PARTS LIST

B-SERIES

SCMTC

PAGE 1 of 1

DRAWING NO. REV DATE
86625 C 10/12/01

Code	Description	Part No.	Qty	Location	
	SWITCHES				
1S1	Key Switch	71154	1	Control Panel	
2S2	Toggle Switch, Horn	85347	1	Control Panel	
3S3	Toggle Switch, Local/Remote	78563	1	Control Panel	
3S4	Toggle Switch, Pump On/Reverse	72003	1	Control Panel	
3S5	Toggle Switch, Test A/B	85346	1	Control Panel	
3S6	E-Stop Switch	85342	1	Control Panel	
	Contact Block, 1NC for 3S6	85343	1	Control Panel	
3S7	E-Stop Switch	85342	1	Remote Control	
	Contact Block, 1NC for 3S7	85343	1	Remote Control	
3S8	Toggle Switch, Horn	85347	1	Remote Control	
3S9	Toggle Switch, Pump On/Reverse	72003	1	Remote Control	
	RELAYS				
1K1	Relay, Engine Start	85348	1	Engine	
	LIGHTS				
1L1	Light, Green, Control On	85355	1	Control Panel	
1L2	Light, Red, Oil Temperature	73775	1	Control Panel	
1L3	Light, Red, Coolant Level	73775	1	Control Panel	
1L4	Light, Red, Oil Pressure	73775	1	Control Panel	
1L5	Light, Red, Alternator	73775	1	Control Panel	
	Bulb for 1L2, 1L3, 1L4, 1L5	72022	4	Control Panel	
2L6	Bulb, E-Stop	85344	1	Control Panel	
2L7	Light, Green, Local	85355	1	Control Panel	
3L8	Light, Yellow, Remote	85356	1	Control Panel	
3L9	Light, Green, Pump On	85355	1	Control Panel	
3L10	Light, Green, Reverse	85355	1	Control Panel	
3L11	Bulb, E-Stop	85344	1	Remote Control	
3L12	Light, Green, Pump On	85355	1	Remote Control	
	GAUGES				
1G1	Hour Meter	74240	1	Control Panel	
1G2	Tachometer	78687	1	Control Panel	
1G3	Coolant Temperature Gauge	78203	1	Control Panel	

REED

ELECTRICAL SCHEMATIC
B-SERIES
PARTS LIST

B-SERIES

SCMTC

PAGE 1 of 1

DRAWING NO.
86625

REV
C

DATE
10/12/01

PN 85358 CONTROL BOX

REMOTE CONTROL

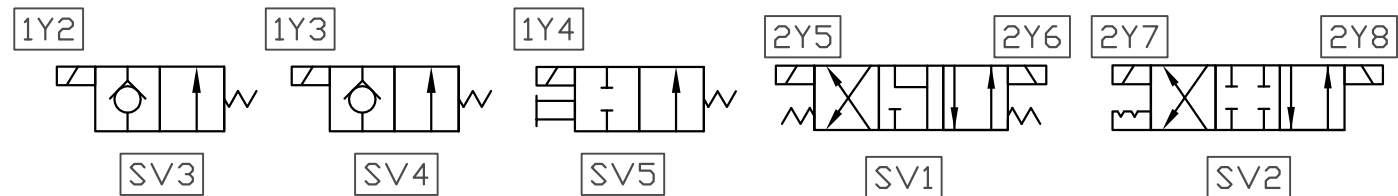
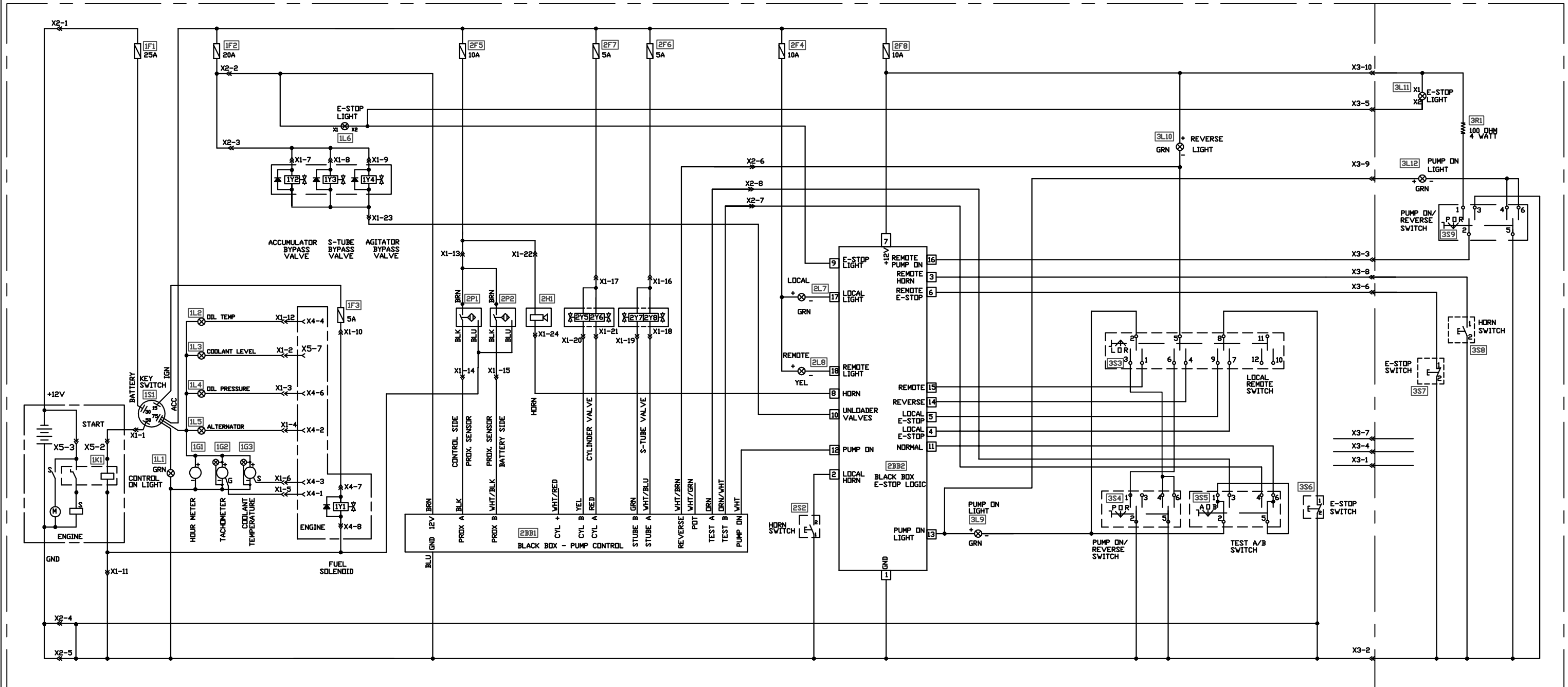

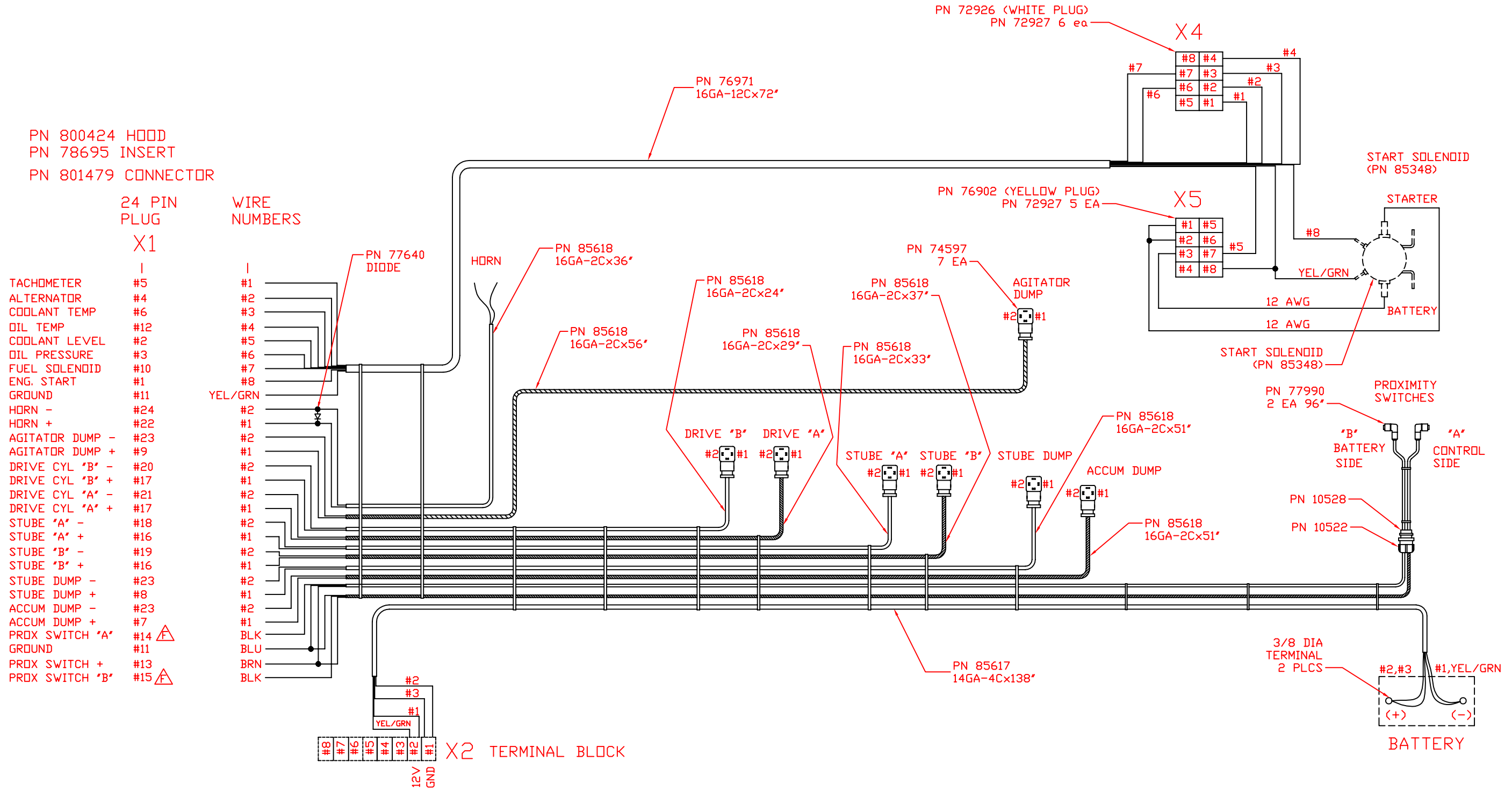

				UNLESS OTHERWISE SPECIFIED, DIMENSIONS ARE IN INCHES AND TOLERANCES ARE:			REED	CONCRETE PLACING EQUIPMENT			
				FRACT	DECIMAL	ANGLE		CHINO, CA 91710			
F	12/3/02	ECN #710	HR	1/32	.030	1/2°	TITLE WIRING HARNESS, B-SERIES				
E	5/16/02	ECN #575	SK	DO NOT SCALE DRAWING							
D	3/14/02	ECN #496	SK	CE	BY	DATE	MATERIAL		PART NUMBER	REV	
C	9/6/01	ECN #373	SK						85396	F	
B	7/10/01	ECN #347	JD	DRAWN		SK	THIS DRAWING IS THE PROPERTY OF REED MANUFACTURING AND IS LOANED WITHOUT CONSIDERATION OTHER THAN THE BORROWER'S AGREEMENT THAT IT SHALL NOT BE REPRODUCED, COPIED, LOANED, OR DISPOSED OF, DIRECTLY OR INDIRECTLY, NOR USED FOR ANY PURPOSE OTHER THAN THAT FOR WHICH IT IS SPECIFICALLY FURNISHED.		SHEET __ OF __		
A	7/5/00	ECN #208	SK								
LTR	DATE	ENGINEERING CHANGE NOTICE #	BY	APPVD							
REVISIONS											

DRAWING NO.	REV	DATE
85396	B	7/10/01

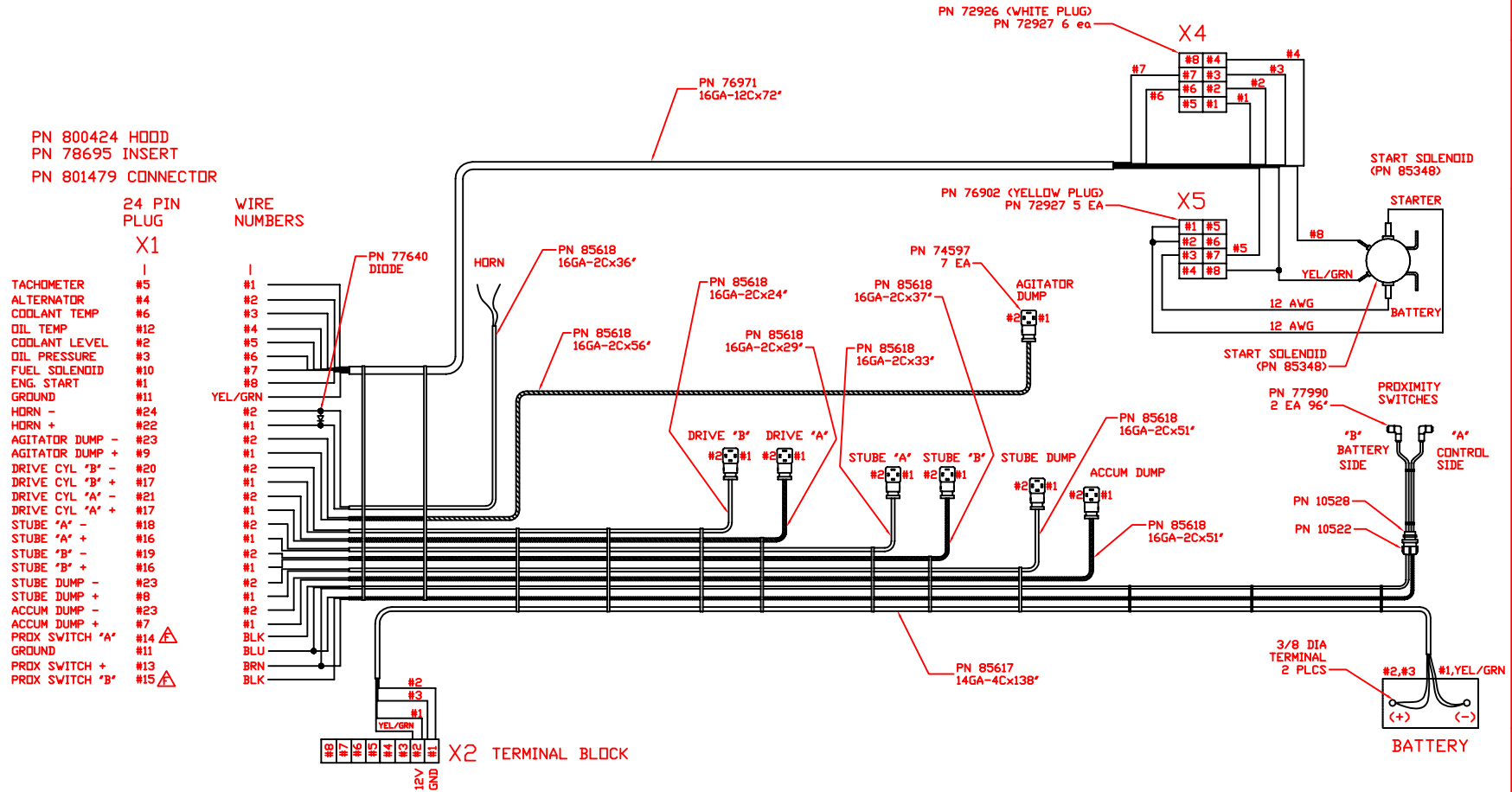

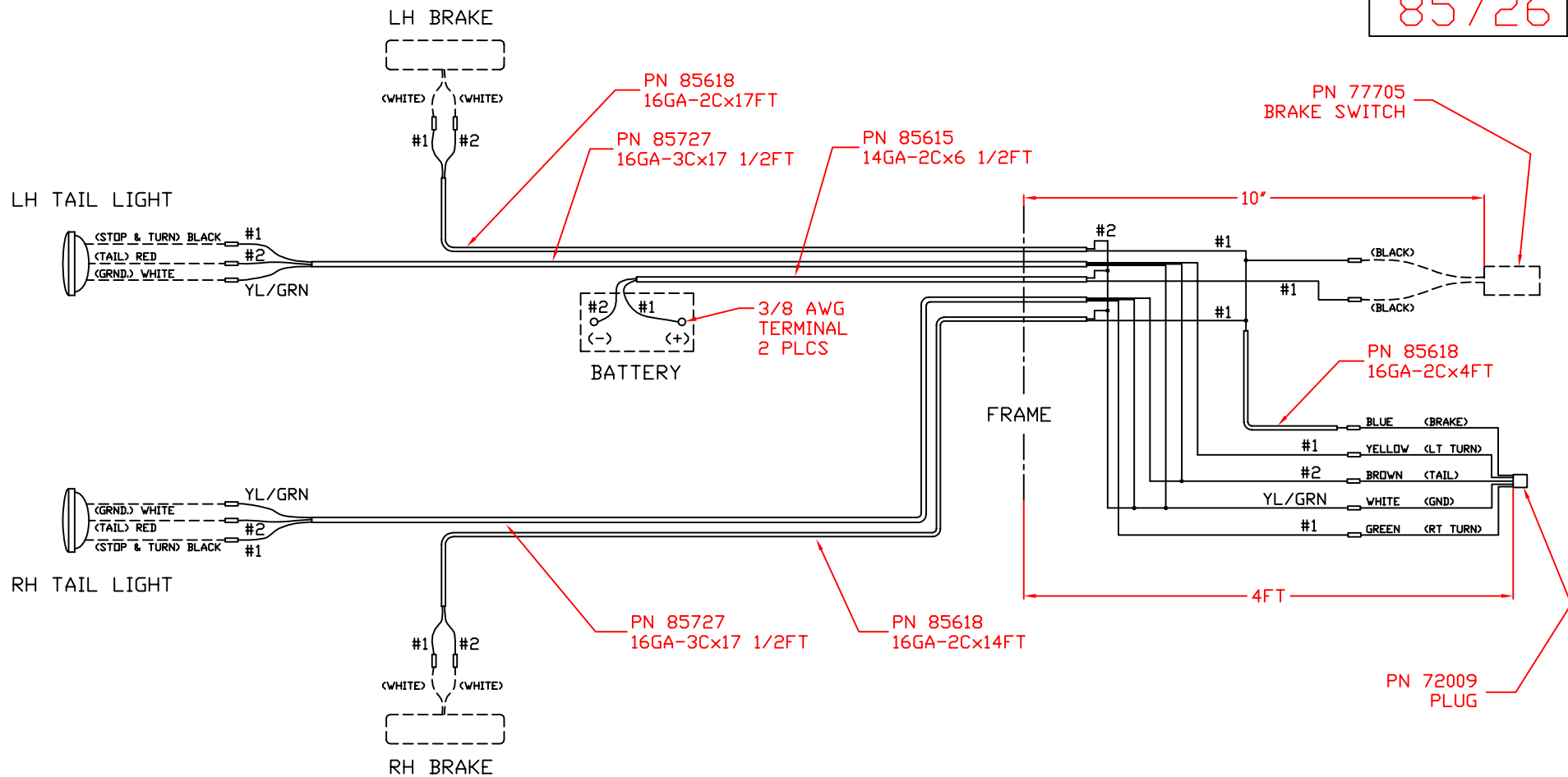

NOTES:

1. ALL CONNECTIONS SOLDERED AND INSULATED WITH HEAT SHRINK TUBING.

UNLESS OTHERWISE SPECIFIED, DIMENSIONS ARE IN INCHES AND TOLERANCES ARE:

FRACT	DECIMAL	ANGLE
1/32	.030	1/2°

REED

CONCRETE PLACING EQUIPMENT
CHINO, CA 91710

DO NOT SCALE DRAWING

TITLE **WIRING HARNESS, TRAILER**

CE

BY DATE

MATERIAL

PART NUMBER REV

LTR DATE ENGINEERING CHANGE NOTICE # BY

DRAWN SK 12/22/99

THIS DRAWING IS THE PROPERTY OF REED MANUFACTURING AND IS LOANED WITHOUT CONSIDERATION OTHER THAN THE BORROWER'S AGREEMENT THAT IT SHALL NOT BE REPRODUCED, COPIED, LOANED, OR DISPOSED OF, DIRECTLY OR INDIRECTLY, NOR USED FOR ANY PURPOSE OTHER THAN THAT FOR WHICH IT IS SPECIFICALLY FURNISHED.

85726

REVISIONS

APPVD

SHEET __ OF __