

# User manual



## **WAITZINGER CONCRETE PUMP**

THP 94/42 R 4 XXT  
THP 125/42 R 4 XXT  
THP 140 H/42 R 4 XXT



**Waitzinger  
Baumaschinen GmbH**

Lessingstraße 4  
89231 Neu-Ulm

Phone: +49 (0) 7 31/7 29 05-0  
Fax: +49 (0) 7 31/7 29 05-30

e-mail: [info@waitzinger.de](mailto:info@waitzinger.de)  
Internet: [www.waitzinger.de](http://www.waitzinger.de)

© Waitzinger Baumaschinen GmbH. All rights reserved.

This user manual is copyright to Waitzinger Baumaschinen GmbH. This document contains instructions and technical drawings and may therefore not be copied and released to third parties in whole or in part. Errors and omissions excepted.

This user manual is part of the supply of the following concrete pump:

The machine number is shown on the serial plate on the vehicle frame behind the cab:

Your appointed Waitzinger Service Office / Waitzinger Customer Service is:



## 0. Contents

<b>1.</b>	<b>Foreword</b> .....	<b>1-1</b>
<b>2.</b>	<b>Safety instructions and information</b> .....	<b>2-1</b>
2.1	Warranty and liability .....	2-1
2.2	Safety symbols .....	2-3
2.3	Safety equipment .....	2-4
2.4	Personal safety equipment .....	2-4
2.5	Ensuring safe working and safety .....	2-4
2.6	Information on risks of injury .....	2-6
2.7	Safety information for setting up .....	2-8
2.7.1	Set-up location .....	2-8
2.7.2	Hazard area .....	2-8
2.7.3	Setting up .....	2-9
2.7.3.1	General .....	2-9
2.7.3.2	Safety distances to the edges of excavation pits .....	2-9
2.7.3.3	Underground .....	2-10
2.7.3.4	Quality of ground .....	2-10
2.8	Safety instructions for remote control .....	2-11
2.9	Safety instructions for the working area .....	2-11
2.9.1	Distributor boom .....	2-12
2.9.2	Conveying pipes .....	2-12
2.9.2.1	Locking the conveying pipe connections .....	2-13
2.9.2.2	Opening the conveying pipe connections .....	2-13
2.9.3	Discharge hose .....	2-14
2.9.3.1	Hazard area for the discharge hose .....	2-14
2.9.3.2	Kinks in the discharge hose .....	2-15
2.9.3.3	Use the guide rod to hold the discharge hose .....	2-15
2.9.3.4	Securing the discharge hose with the catch .....	2-15
2.9.4	Agitator .....	2-16
2.10	Safety instructions at concrete pressures in excess of 85 bar .....	2-16
2.11	Safety instructions for maintenance and repair .....	2-16
2.12	High tension overhead electric cables .....	2-17
2.12.1	Safety distance .....	2-18
2.12.2	High-tension contacts .....	2-19
2.12.2.1	Automatic reconnection .....	2-20
2.12.3	Static discharge .....	2-20
2.12.4	Immediate measures .....	2-21
2.12.4.1	Actions after contacting a high-tension overhead cable .....	2-21



2.13	Operation in winter .....	2-20
2.14	Storms and thunderstorms .....	2-21
2.15	Noise emission measurement .....	2-21
2.16	Environmental protection .....	2-21
2.17	First aid .....	2-21
2.18	Responsible persons .....	2-22
2.18.1	Personnel .....	2-22
2.18.2	Requirements .....	2-22
2.18.3	Skills .....	2-22
2.18.4	Machine operator's responsibilities .....	2-22
2.19	Safety and warning notices .....	2-23
<b>3.</b>	<b>Technical data .....</b>	<b>3-1</b>
3.1	Leading dimensions of the truck-mounted concrete pump, .....	3-1
3.2	Truck .....	3-1
3.3	Distributor boom 42 R 4 XXT .....	3-2
3.4	Concrete pump .....	3-4
<b>4.</b>	<b>Description .....</b>	<b>4-1</b>
4.1	Proper use .....	4-1
4.2	Structure and function of the concrete pump .....	4-2
4.2.1	Structure of the concrete pump .....	4-2
4.2.2	Function of the concrete pump .....	4-4
4.2.2.1	Distributor boom .....	4-4
4.2.2.2	Outriggers .....	4-4
4.2.2.3	Control .....	4-4
4.2.2.4	Central lubrication .....	4-4
4.2.2.5	Function of the concrete pump .....	4-5
4.2.2.6	Method of operation of the concrete pump .....	4-6
<b>5.</b>	<b>Controls and displays .....</b>	<b>5-1</b>
5.1	Controls and displays for the truck-mounted concrete pump, .....	5-1
5.2	Control panel desk .....	5-2
5.3	Control panel agitator / water pump .....	5-3
5.4	Boom control block .....	5-4
5.5	Outrigger control block, left .....	5-5
5.6	Outrigger control block, right .....	5-6
5.7	Control cabinet .....	5-7
5.8	Changeover to transfer shift gearbox (in the cab) .....	5-8
5.9	Surplus concrete discharge opening .....	5-8



5.10	Water tank shut-off valve .....	5-8
5.11	Water connection, rear .....	5-9
5.12	Radio remote control / cable remote control .....	5-9
5.13	Emergency Stop button .....	5-10
5.14	Control elements on the hydraulic block .....	5-10
<b>6.</b>	<b>Driving, towing, loading .....</b>	<b>6-1</b>
6.1	Driving .....	6-1
6.1.1	Before a journey .....	6-1
6.1.2	During the journey .....	6-1
6.2	Towing .....	6-1
6.3	Loading .....	6-2
<b>7.</b>	<b>Starting up and operating .....</b>	<b>7-1</b>
a.	Personal safety equipment .....	7-1
b.	General information for operating the truck-mounted concrete pump .....	7-2
b1.	Before starting up .....	7-2
b2.	During operation .....	7-2
b3.	At the end of operations .....	7-2
7.1	Setting up the truck-mounted concrete pump .....	7-3
7.2	Adjustments and actions before starting up. ....	7-4
7.2.1	Changeover to transfer shift gearbox .....	7-4
7.2.2	Emergency Stop .....	7-5
7.2.3	Selecting the operating mode .....	7-6
7.3	Operating the outriggers .....	7-6
7.3.1	Stability checking .....	7-7
7.3.2	Extending / retracting the outriggers .....	7-7
7.3.2.1	Back-up operation .....	7-8
7.3.3	Functions at outrigger control block, left .....	7-8
7.3.4	Functions at outrigger control block, right .....	7-8
7.3.5	Building up the outrigger. ....	7-9
7.4	Distributor boom operation .....	7-10
7.4.1	Distributor boom operation using the master control block .....	7-10
7.4.1.1	Back-up slewing function .....	7-13
7.4.2	Controlling the distributor boom using the radio remote control pendant .....	7-14
7.4.3	Controlling the distributor boom using the cable remote control pendant .....	7-15
7.5	Pump operation .....	7-16
7.5.1	Motor Start/Stop, Speed control .....	7-16
7.5.2	“Pump/Suck” control at the control panel desk .....	7-16
7.5.3	“Pump/Suck” control at the radio remote control / cable remote control .....	7-17



# CONTENTS

## CHAPTER 0



7.5.4	Back-up function for “Pump/Suck”	7-17
7.5.4.1	Pumping with the control panel desk or via radio remote control/cable remote control	7-17
7.5.4.2	Pump control at the hydraulic control block	7-19
7.5.5	Agitator	7-20
7.5.6	Water pump	7-21
7.5.7	Vibrator	7-21
7.5.8	Horn/Reset	7-21
7.5.9	Light	7-22
7.5.10	Concrete pump manometer	7-22
7.5.10.1	Distributor boom manometer	7-22
7.5.10.2	Filter clogging display	7-23
7.5.10.3	Manometer for transfer shift gearbox	7-23
7.6	Instructions for pump operation	7-24
7.6.1	Instructions for pumping	7-24
7.6.1.1	Causes of blockages	7-25
7.6.2	General instructions for pumping	7-25
7.6.3	Instructions for pumping (depending on the material to be pumped)	7-26
7.6.4	Instructions for pumping (depending on the machine)	7-27
7.6.4.1	Measures to reduce the oil temperature	7-28
7.7	Cleaning the conveying pipework	7-28
7.7.1	General	7-28
7.7.2	Suction cleaning	7-28
7.7.3	Cleaning with pressurised water	7-29
7.7.4	Draining the remaining concrete	7-31
7.8	Water tank	7-31
7.8.1	Filling up / topping up with water by removing the cover	7-31
7.8.2	Filling with water using the C-coupling	7-31
7.8.3	Filling with water from the mixer truck	7-32
7.8.4	Operation in winter	7-32
<b>8.</b>	<b>Trouble-shooting</b>	<b>8-1</b>
8.1	General information	8-1
8.2	Tracing faults	8-1
<b>9.</b>	<b>Maintenance &amp; Inspection</b>	<b>9-1</b>
9.1	General information	9-1
9.2	Safety instructions for maintenance and inspection	9-1
9.2.1	Lubricants and solvents	9-2
9.2.2	Sealing rings (containing fluorine)	9-3
9.2.3	Oils and greases	9-3



9.2.4	Paints, varnishes and thinners .....	9-4
9.2.5	Glues, adhesives and solvents .....	9-4
9.2.6	Battery acid .....	9-5
9.2.7	Safety precautions when charging batteries .....	9-6
9.2.8	Safety instructions for welding work .....	9-6
9.3	Tightening torques for screw connections .....	9-7
9.4	Maintenance schedule .....	9-8
9.5	Lubrication .....	9-12
9.5.1	Central lubrication system .....	9-12
9.5.1.1	Checking the central lubrication system .....	9-12
1.	Starting the lubrication system manually .....	9-12
2.	Checking the grease points on the hopper (Fig. 9.2) .....	9-12
3.	Checking the operation of the lubrication distributor .....	9-12
4.	Checking the lubrication pipes .....	9-12
5.	Checking the grease nipples for manual lubrication .....	9-13
6.	Lubricating “manually” .....	9-13
7.	Blocked grease points .....	9-13
9.5.2	Manual lubrication .....	9-14
9.5.3	Sliding surfaces .....	9-14
9.5.4	Overview of grease points .....	9-14
9.5.5	Reference tables for hydraulic oils, greases and gear oils .....	9-16
9.6	Changing filters .....	9-19
9.6.1	General .....	9-19
9.6.2	High-pressure filters for the boom and hydraulic pumps .....	9-20
9.6.3	Return flow filter .....	9-20
9.6.4	In-line filter cartridge .....	9-21
9.7	Changing the oil .....	9-21
9.7.1	Changing the oil in the slewing gearbox .....	9-21
9.7.2	Changing the oil in the transfer shift gearbox .....	9-22
9.7.3	Changing the oil in the hydraulic system .....	9-22
9.8	Performing tests .....	9-24
9.8.1	Measuring the wall thickness of the conveying pipework .....	9-24
9.8.2	Minimum wall thicknesses and conveying pipework operating pressures .....	9-25
9.8.3	Adjusting the S-valve .....	9-26
9.8.4	Checking the chain tension on the outrigger feet .....	9-26
9.8.5	Checking the backlash in the slewing gearbox .....	9-27
9.8.6	Checking the boom backlash (ball bearing slewing rim in the slewing gearbox) .....	9-27
9.8.7	Checking the operation of the sensors .....	9-28
9.9	Replacing worn parts .....	9-29
9.9.1	Exchanging the wear plate and wear ring .....	9-29



# **CONTENTS**

## **CHAPTER 0**

---



9.9.2	Changing the conveying piston .....	9-30
9.9.3	Changing / turning the conveying cylinder .....	9-32
9.9.4	Changing the agitator blades .....	9-33
9.9.5	Changing the agitator seals .....	9-34
9.9.6	Changing the agitator wear sleeves .....	9-34
9.10	Changing the conveying pipework .....	9-35
9.11	Crack-checking on the steelwork .....	9-35
9.12	Checking the hoses .....	9-36
9.13	Cleaning the machine .....	9-36
9.14	Disposal of the machine .....	9-37
<b>10.</b>	<b>Repair work .....</b>	<b>10-1</b>
<b>11.</b>	<b>List of operators of the equipment .....</b>	<b>11-1</b>
<b>12.</b>	<b>Maintenance and modifications list .....</b>	<b>12-1</b>





## 1. Foreword

**Dear customer,**

Please read this user manual carefully before first using your truck-mounted concrete pump, so as to ensure that you use it safely and effectively.

We have written this user manual to familiarise you with the design, use, operation and operating conditions, and to list the servicing and maintenance work required, together with information on safe working.

**Before starting to use the truck-mounted concrete pump, be sure that all the safety conditions have been satisfied.**

This user manual forms part of the total documentation package for the truck-mounted concrete pump. It relates exclusively to the superstructure that is fitted to the truck. For the truck itself see the separate user manual issued by the truck manufacturer. There may be separate user manuals for certain components and options. These user manuals should also be read and complied with.





All repair work should be performed only by authorised skilled staff.

If maintenance work is neglected or improperly performed, we may no longer be liable to perform our warranty obligations under our conditions of supply.

Only original **WAITZINGER** spare parts ensure quality and interchangeability.



### **NOTE:**

-  **Safety instructions should be complied with at all times!**
-  **We reserve the right to make technical changes and improvements to the equipment and its components from the illustrations and data set out in this user manual.**
-  **This user manual is applicable only insofar as the truck-mounted concrete pump corresponds to the version and equipment described.**
-  **In the following sections the truck-mounted concrete pump is also referred to as the “machine” or “equipment”.**

Only qualified and trained personnel over 18 years of age may work on and with the truck-mounted concrete pump.

Our customer service department will be pleased to offer you further information and advice if despite consulting this user manual you encounter any problem with your truck-mounted concrete pump.

We wish you all the best in trouble-free driving and use of your truck-mounted concrete pump.

***The management***





## 2. Safety instructions and information



- ☞ In addition, please comply with the safety instructions and information for the truck itself!
- ☞ We expressly draw to your attention that we accept no liability for damage and operating failures that arise due to disregard of this user manual!

☞ This section contains safety instructions which must be complied with at all times when the machine is in operation. These instructions are highlighted in the text by particular symbols.

### 2.1 Warranty and liability

- ☞ After the machine has been delivered, check the completeness of the scope of supply against the delivery note.
- ☞ If anything is missing, or damage has occurred in transport, please report this immediately to **WAITZINGER**.
- ☞ The machine as delivered is in accordance with current technology and complies with the mandatory safety standards.
- ☞ The machine should be operated only when it is in good technical condition and in a proper manner (see section 4.2 “Proper use”). Any use other than this or beyond this is deemed to be improper use.
- ☞ If the machine is used inappropriately or improperly risks to life and limb can arise, and/or damage to the machine or other property. **WAITZINGER** accepts no liability for damage that arises under such circumstances. The risk is borne solely by the user of the machine.
- ☞ Proper use of the machine also requires compliance by the user with national regulations for accident prevention and environmental protection, with recognised professional rules for good and safe working practice and with this user manual.
- ☞ No changes, additions or modifications of any sort may be made to the machine without express permission from **WAITZINGER**. Original spare parts and approved accessories from **WAITZINGER** contribute to safety. No liability is accepted for the consequences arising from use of other parts.
- ☞ Persons working on or with the machine must have read and understood the user manual before starting work and have appropriate physical and mental capabilities.
- ☞ Disregard of these instructions and information can lead to risks to life and limb, and/or damage to the machine or other property.



☞ If, due to disregard of / failure to comply with the instructions and information in this user manual or the operating and maintenance handbook for the overall system, accidents leading to personal injuries and/or damage to property occur, this circumstance releases **WAITZINGER** from any liability for direct or consequential damages such as personal injuries, damage to property not covered by the contract, loss of profits and interruption to production that comes under the heading

**“Product liability“**

to **WAITZINGER**.



## 2.2 Safety symbols



### **DANGER:**

This symbol indicates an immediate danger to life and health of personnel! Disregard of this information can lead to serious effects on health, through to life-threatening injuries and even death.



### **WARNING:**

This symbol indicates a possible danger to life and health of personnel! Disregard of this information can lead to serious effects on health, through to life-threatening injuries.



### **CAUTION:**

This symbol indicates a situation that may possibly be dangerous! Disregard of this information can lead to minor injuries or damage to property.

These symbols are placed in front of the text to which they refer, in order to alert the operator to possible hazards before undertaking any activity on the machine / equipment.



### **NOTE:**

This symbol is used to draw the operator's attention to notes and specially useful information for technical requirements and handling the machine / equipment.

These notes assist in making the best use of the functions of the machine / equipment.

This symbol follows the text to which it relates.



### 2.3 Safety equipment

- ☞ The safety equipment fitted to the whole system must be given particular attention.
- ☞ The safety equipment must be continually checked for correct operation.
- ☞ Safety equipment that operates on the basis of set values must not be reprogrammed without expressed permission from **WAITZINGER**.
- ☞ If the safety equipment is not operational or is malfunctioning, the truck-mounted concrete pump must not be used.

### 2.4 Personal safety equipment

In the entire working area of the truck-mounted concrete pump, suitable safety equipment should be worn, particularly when handling mortar additives.

The symbols for the necessary safety equipment are shown in the graphics panel alongside.

The symbols shown are as follows:

1. Hard hat
2. Safety boots
3. Ear defenders
4. Safety gloves
5. Safety glasses
6. Face mask
7. Protective clothing
8. Safety harness



Fig. 2.1 Symbols for personal safety equipment

### 2.5 Ensuring safe working and safety

The following safety regulations were taken into account when designing the truck-mounted concrete pump:

- ☞ pr EN 12001 “Conveying, spraying and distribution machines for concrete and mortar”
- ☞ EN 292 “Safety of machines, equipment and systems”
- ☞ EN 60204-1 “Safety of machines; electrical equipment for industrial machines”
- ☞ EMC “Electromagnetic compatibility - Directive 89/336/EWG”



The following instructions for ensuring health and safety at work must be observed by the user, the supervisor and the operator of the equipment at all times:

- ☞ VBG ZH1/653 “Health and safety when operating truck-mounted concrete pumps”
- ☞ VBG ZH1/573 In the German Federal Republic – “Directives for truck-mounted concrete pumps and distributor booms”
- ☞ BGR 182 “Rules for handling truck-mounted concrete pumps and distributor booms”
- ☞ VDM 24119 “Graphical signs”
- ☞ BGG “Basic requirements, selection and qualification of truck-mounted concrete pump operators”
- ☞ VDMA “Safety Handbook”
- ☞ VBG 1 “General instructions”
- ☞ VBG 4 “Electrical systems and equipment”
- ☞ VBG 5 “Power-operated equipment”
- ☞ VBG 8 “Winches, hoists and drawgear”
- ☞ VBG 9 “Cranes”
- ☞ VBG 9a “Load-bearing equipment for use as lifting gear”
- ☞ VBG 12 “Accident prevention regulations (UVV) for vehicles”
- ☞ VBG 37 “Accident prevention regulations (UVV) for building work”
- ☞ VBG 109 “First aid”
- ☞ VBG 121 “Noise”
- ☞ VBG 125 “Safety signage at the workplace”
- ☞ EC directive 89/655/EWG “Minimum machine instructions guidelines”
- ☞ EC directive 98/37 “Essential machine guidelines”
- ☞ EC directive EN 60204-1 “Electrical equipment of machines, part 1”
- ☞ EG directive 73/23 “Insulation of cables”
- ☞ EG directive “Electromagnetic compatibility EMC”
- ☞ EG directive 92/58 “Personal safety equipment”
- ☞ EG directive 89/689 “Waste disposal”



- ☞ Work on or with the machine may be performed only by suitably instructed reliable personnel and/or technical staff.
- ☞ Before starting work it should be determined which personnel shall perform the necessary operating and maintenance work.
- ☞ When operating the machine the legislation and regulations applicable at the place of use should be observed. In the interests of safe working procedures, the user, supervision and equipment operator are responsible for complying with regulations.
- ☞ Before starting work, all necessary functional checks should be performed on the machine.
- ☞ Items not required in the immediate working process (tools, lubricants, cleaning materials, etc.) must be stowed only in their proper places, since otherwise they may obstruct safe operation.
- ☞ During cleaning work, especially with solvents or petrol washes, safety gloves and safety glasses must be worn. No naked lights or smoking when cleaning is being performed! Disposal of consumable materials to TA waste code 524.02 should be to EC directive 91/689/EWG.
- ☞ Consumables such as lubricants, cleaning materials during maintenance, repair and oil change should be collected in suitable containers and disposed of in accordance with regulations (to EC directive 75/439/EWG and statutory instruments under §§ 5a, 5b AbfG and AltöIV).

## **2.6 Information on risks of injury**

Improper use of the truck-mounted concrete pump may lead to the following injuries:

- ☞ Injuries to the eyes due to splashes of concrete, concrete mixing water or other chemical substances.
- ☞ Injuries to the eyes and other injuries due to hydraulic oil spurting out if the system is not depressurised.
- ☞ Injuries due to centrifugal forces of bursting couplings, bursting pipework or plugs blown out of the concrete conveying pipework.
- ☞ Hazards of touching electrical cables.
- ☞ Electric shock (which can be fatal) from machines with electrical drives, if electrical connections are not properly made or the connecting cables are defective.
- ☞ Danger of tipping over due to collapse of the outriggers.
- ☞ Injuries due to burns if hot parts are touched.
- ☞ Injuries due to falling pipes.
- ☞ Injuries to personnel due to inadvertent operation of the machine controls and hence inadvertent operation of the machine.





- ☞ Head and shoulder injuries due to concrete discharging from the discharge hose or concrete conveying pipes.
- ☞ Injuries due to parts falling from the concrete conveying pipes, if these are not properly aligned.
- ☞ Injury to the hose operator from the discharge hose if this was secured in the catch and then suddenly swings out on release.
- ☞ The truck-mounted concrete pump can roll away if the brakes or outriggers are released.
- ☞ Injuries due to opening the conveying pipes when they are under pressure due to a blockage.
- ☞ Injuries due to reaching into the agitator hopper, or falling into it.
- ☞ Injuries due to slipping from or on the oily and slippery walkways on the machine.
- ☞ Injuries during pumping operations due to reaching into the water tank at the same time as the piston is in motion.
- ☞ Amputation of the hand if the arm is trapped in the S-valve when cleaning with the flap elbow open.
- ☞ Injuries due to tripping over cables, hoses or reinforcing rods.
- ☞ Injuries due to being caught in the mixing hopper or its parts (chute).
- ☞ Injuries due to unsecured conveying pipes slipping down or falling down.
- ☞ Risk of crushing at the complete outriggers.
- ☞ Injuries due to unintended movement of the distributor boom following inadvertent operation of the controls.



## 2.7 Safety information for setting up



### **DANGER:**

- ☞ The distributor boom should not be moved before all the outriggers have been fully extended and all support cylinders correctly set!
- ☞ The truck-mounted concrete pump must not be driven with the distributor boom deployed!
- ☞ The safety regulations for the country in which the truck-mounted concrete pump is being operated must be complied with!

### 2.7.1 Set-up location

*When selecting the set-up location, the following aspects should be considered:*

- ☞ Check the route to the set-up location, if necessary have someone guide the driver to the location.
- ☞ Keep a safe distance from obstacles such as site cranes, buildings and equipment.
- ☞ Check there is sufficient room to extend the outriggers.
- ☞ Check there is sufficient room to deploy the distributor boom.
- ☞ Check there is sufficient ventilation to clear the vehicle exhaust gases.

### 2.7.2 Hazard area

The hazard area is the area around the truck-mounted concrete pump within which a person could encounter movements of the distributor boom, the truck and the outriggers, and thus be at risk.



### **DANGER:**

- ☞ There is a risk of crushing when slewing and extending the outriggers and when extending the support cylinders!
- ☞ The operator must continually monitor the hazard area!

- ☞ The outriggers must not be extended when personnel are in their area of movement. Interlock the outriggers hydraulically or mechanically.



- ☞ Press the Emergency Stop button immediately if anyone approaches the hazard area.
- ☞ Extending the outriggers on only one side may be performed only if the manufacturer has approved this after consideration of the stability of the arrangement, and the distributor boom is restricted so that it can only move within the slewing arc specified for the situation.

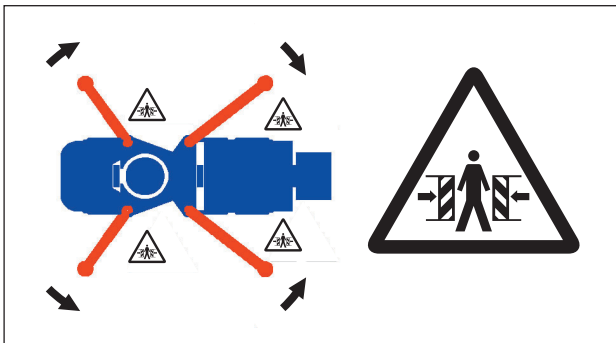

**Fig. 2.2** Crush hazard in the slewing area of the support feet

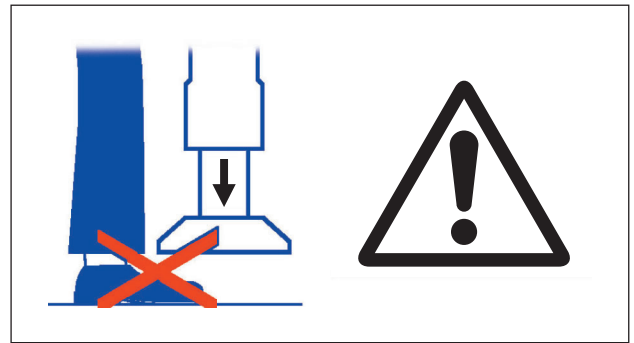

**Fig. 2.3** Crush hazard when extending the support feet

## 2.7.3 Setting up

### 2.7.3.1 General

- Set up the truck-mounted concrete pump so that stability is assured.
- It must be at a sufficient distance from embankments, pits, excavations and other holes so that the pressure of the outriggers on the ground does not cause it to break into the hole.

### 2.7.3.2 Safety distances to the edges of excavation pits

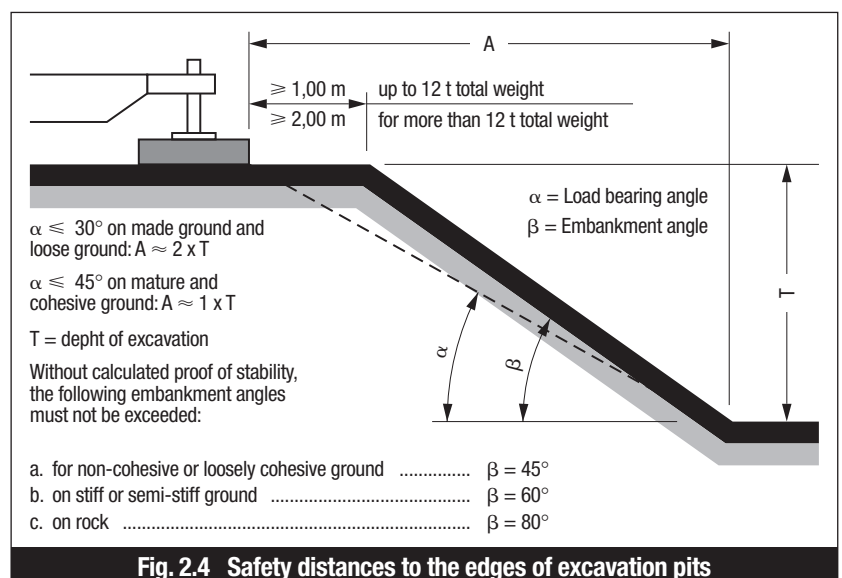

**Fig. 2.4** Safety distances to the edges of excavation pits



### 2.7.3.3 Underground

The ground must be flat, horizontal and without voids.

On sloping ground the outriggers can slip from timber baulks.

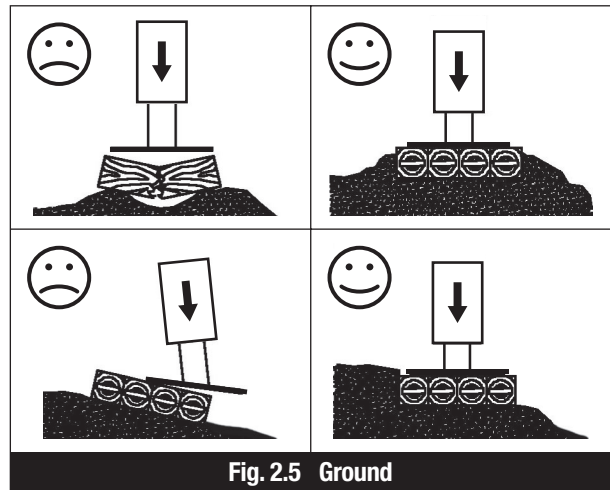

Fig. 2.5 Ground

### 2.7.3.4 Quality of ground

The ground must be of a quality sufficient to ensure the stability of the machine and the distributor boom. The outriggers exert a surface pressure up to 260 N/cm<sup>2</sup> (26 kg/cm<sup>2</sup>). If the ground quality is insufficient to accept this the bearing area should be enlarged with two crossed layers of support plates. See DIN 1054 for recommended values.

Types of ground	Permissible ground pressure N/cm <sup>2</sup> (kg/m <sup>2</sup> )
A. Backfilled ground, not artificially consolidated	0-10 (0-1)
B. Mature, obviously undisturbed ground:	
1. Silt, marsh, topsoil	0
2. Non-cohesive, sufficiently firm ground:	
fine to medium sand	15 (1,5)
Coarse sand to gravel	20 (2,0)
3. Cohesive ground:	
Mushy	0
Soft	4 (0,4)
Stiff	10 (1,0)
Semi-hard	20 (2,0)
Hard	30 (3,0)
4. Rock, unweathered with little fissuring and in a good position	150-300 (15-30)

Fig. 2.6 Permissible ground pressures for various types of ground



## 2.8 Safety instructions for remote control

- ☞ The remote control is active when the connecting cable is plugged into the machine.
- ☞ When remote control is in operation, the pendant must not be put down unless the Emergency Stop button has been pressed. To restart the machine (also after rectifying a fault), the Emergency Stop button must be released (twist it in the direction of the arrow, or pull it outwards).
- ☞ Before starting up the remote control, press the Emergency Stop button, so that all control and regulation devices for remote control are set to “0”.
- ☞ During interruptions, pauses whilst pumping takes place, also during maintenance and repair work, secure the remote control against unauthorised use e.g. by locking it in the cab or in a tool box etc.

## 2.9 Safety instructions for the working area

- ☞ During operation of the truck-mounted concrete pump, the machine operator is responsible for the entire working area. The working area must be fully within his field of view, otherwise an assistant is necessary. When leaving the machine, secure it against unauthorised use and self-acting movement.
- ☞ Barrier off the working area to other traffic in accordance with instructions.
- ☞ Personal protective clothing (hard hat, safety glasses, face mask, safety gloves, etc.) must be worn within the entire working area, in particular when working with cement or with chemical mortar additives.
- ☞ Unauthorised access to the hazard area of the machine is prohibited. If anyone is in the hazard area, first warn them, then if they still do not leave the hazard area, shut down the machine.
- ☞ Never, irrespective of whether the machine is running or not, reach with the hand into the transfer mechanism, pre-compression system, water tank, transfer tube or other moving part of the machine. Always first switch the engine off and depressurise the system.
- ☞ When climbing on to and off the machine, use the handrails and the steps. Keep steps, platforms, controls and regulation devices etc. free of dirt, oil, snow and ice.
- ☞ Whilst the machine is running never remove any guards (e.g. water tank cover), nor disable or bypass any safety devices (e.g. limit switches or mechanical catches for the grill interlocks).
- ☞ Whilst the pump is running, keep off the machine. All operation should be by remote control only.



### **DANGER:**

- ☞ Under the slewing area of the distributor boom there is a risk of injury due to falling parts.
- ☞ At the discharge hose there is a there is a risk of injury due to falling concrete.
- ☞ Unauthorised persons must leave the hazard area immediately. If necessary, stop the machine immediately.



## 2.9.1 Distributor boom

- ☞ The operator must ensure that no unauthorised person is in the hazard area.
- ☞ The distributor boom should not be moved before the outriggers have been fully extended and all support cylinders correctly set. The truck-mounted concrete pump must not be driven with the distributor boom deployed.
- ☞ Do not use the distributor boom as a crane jib or as a lever to push aside obstacles (such as trees).
- ☞ The distributor boom should be not be deployed beyond the lengths stated in the user manual.
- ☞ Add extensions to the conveying pipe to the distributor boom only if they do not place any additional load on the boom.
- ☞ When the wind reaches the critical speed, retract the distributor boom and secure it. Retract the boom and secure it also at the end of the day's work.
- ☞ If hazard areas are out of the operator's field of view, employ an assistant. Such hazard areas can be those within the slewing area of the distributor boom or the discharge hose.
- ☞ When the wind reaches the critical speed, retract the distributor boom and secure it. Retract the boom and secure it also at the end of the day's work. The machine operator must ensure that when moving the distributor boom the clearances to overhead electric cables are maintained as set out in the table.

## 2.9.2 Conveying pipes

- ☞ The machine operator must securely fasten the conveying pipes, particularly riser pipes, that are not incorporated in the distributor boom and ensure that the forces arising in the components and other parts of the design are appropriately taken up. The conveying pipes must be aligned so as to avoid kinks, sharp bends and damage in operation.



- ☞ If worn or defective components (high pressure hoses etc.) are not immediately replaced, **WAITZINGER** will not accept product liability. Conveying pipes are not under stress when the distributor boom is stowed, and can thus be replaced without problems at that time. If conveying pipes are replaced when the distributor boom is deployed, stresses may be introduced during assembly.
- ☞ To ensure a long working life for the conveying pipes, after delivering approx. 6,000 m<sup>3</sup>, rotate all conveying pipes 120° clockwise, and rotate the elbows 180°. Check the minimum wall thicknesses and operating pressure.



### WARNING:

If you use compressed air for cleaning the conveying pipes, this is at your own risk! **WAITZINGER** accepts no liability for the risks involved. If nevertheless you do use compressed air for cleaning, information can be found in an additional sheet which can be requested from **WAITZINGER** as required.

#### 2.9.2.1 Locking the conveying pipe connections

- All conveyor pipe couplings must be secured with spring clips (arrowed) against bursting open.

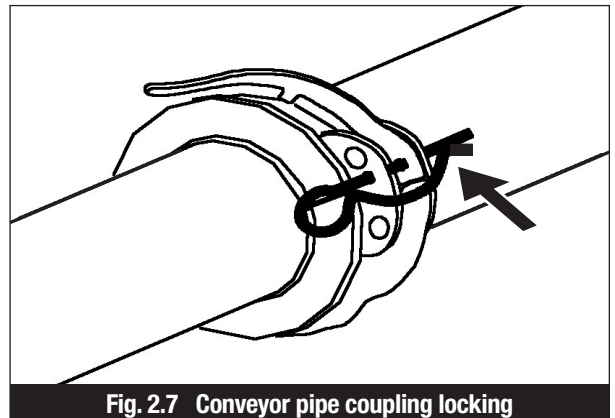

Fig. 2.7 Conveyor pipe coupling locking

#### 2.9.2.2 Opening the conveying pipe connections

- Conveying pipe connections must be knocked apart and opened only in the depressurised state.
- Always pump backwards 1-2 piston strokes.

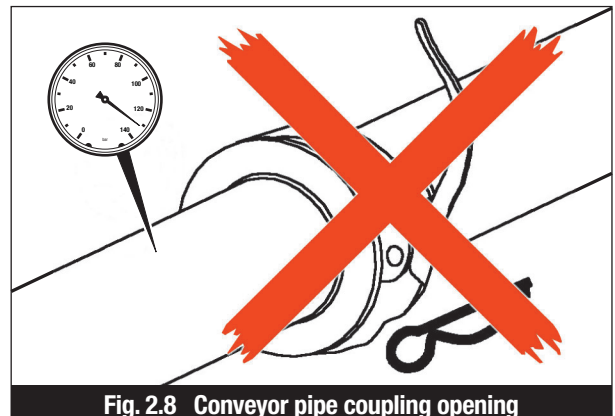

Fig. 2.8 Conveyor pipe coupling opening



### 2.9.3 Discharge hose



#### **DANGER:**

**When pumping, after interruptions, after undoing a plug or when cleaning the conveying pipes, the discharge hose can swing out.**

- ☞ The hazard area around the discharge hose has a diameter twice the length of the discharge hose.
- ☞ If anyone is within this hazard area, stop the machine immediately and press the Emergency Stop button.
- ☞ If the discharge hose becomes snagged, never use the distributor boom to pull it free. This might put the stability of the machine at risk or overload the steel structure!
- ☞ The freely suspended discharge hose must not be extended with additional couplings, discharge pieces or other hazardous discharge arrangements.
- ☞ The discharge hose must not be extended beyond the length supplied by the manufacturer.
- ☞ If the machine operator connects another discharge piece in place of the discharge hose, this must not be guided manually.
- ☞ The machine operator must use only the end hose approved by the manufacturer for delivering concrete into high places.

#### 2.9.3.1 Hazard area for the discharge hose

- ☞ When the pump is started or a blockage occurs, the end hose must hang freely.
- ☞ There is an injury risk of being struck by the discharge hose or by stones shooting out of it.

**Hazard area = 2 x discharge hose length**







### 2.9.3.2 Kinks in the discharge hose

- Never kink the discharge hose whilst the pump is running. Blockages increase the risk of accidents.

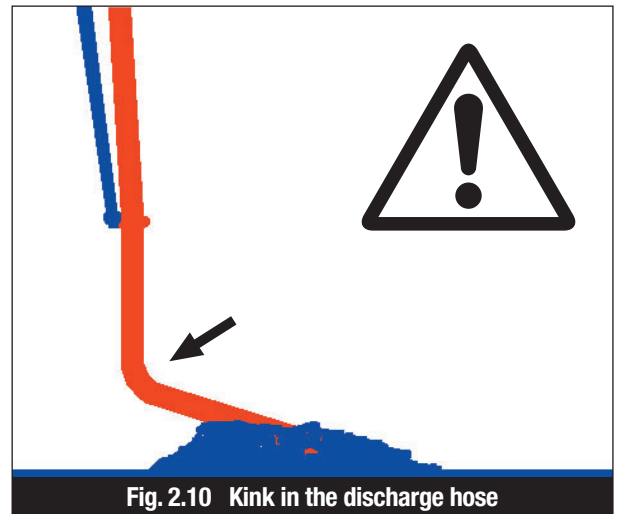

### 2.9.3.3 Use the guide rod to hold the discharge hose

- Do not hold the discharge hose by hand; if necessary to guide it use the guide rod as shown here.

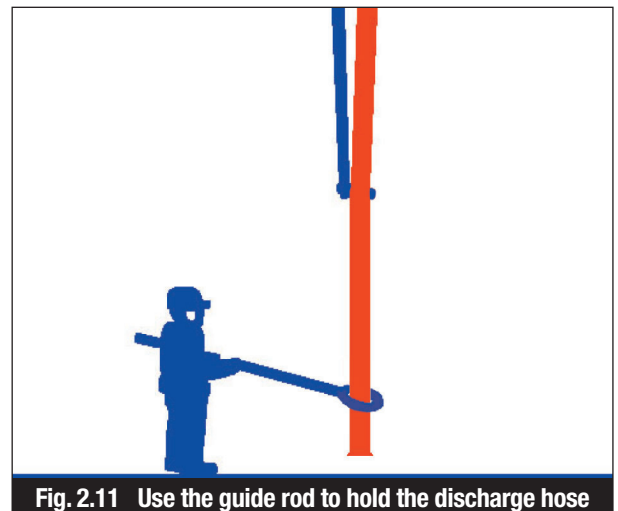

### 2.9.3.4 Securing the discharge hose with the catch

- Always secure the discharge hose with the catch

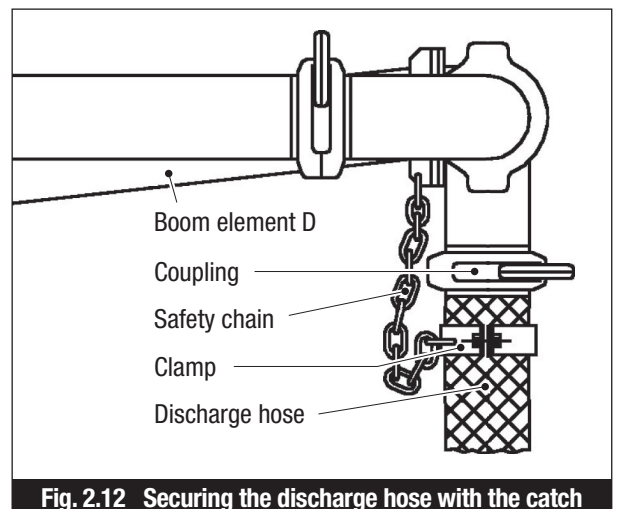



### 2.9.4 Agitator

- ☞ To avoid air being sucked into the system, leading to spurting concrete, the hopper must be kept filled with concrete up to the level of the agitator shaft.
- ☞ Keep the safety grill closed in order to avoid injuries due to reaching into the agitator hopper, or falling into it. Do not place anything on the safety grill. Do not step on the safety grill.
- ☞ Never operate the machine unless the safety grill is closed and bolted into place or otherwise secured.

### 2.10 Safety instructions at concrete pressures in excess of 85 bar

If concrete is to be pumped at pressures in excess of 85 bar, the discharge must only be through the side outlet, not through the distributor boom. The machine operator must take the following safety precautions and perform the following tests:

- a. Use only pipework supplied by the concrete pump manufacturer. At concrete pressures between 85 bar and 130 bar, high-pressure pipework is necessary.
- b. Perform a water pressure test on pipes and couplings no later than after pumping 2000 m<sup>3</sup>, at a pressure 30 % greater than the anticipated operating pressure.
- c. All couplings, seals and pipe elbows that are less than 3 m from operating personnel should be regularly replaced. (e.g. after pumping each 1,000 m<sup>3</sup> of concrete)

### 2.11 Safety instructions for maintenance and repair



#### **WARNING:**

**Rectifying faults, repairs and maintenance work may be performed only when the main drive engine is switched off, hydraulic units are depressurised and conveying pipework is also depressurised. Take out the ignition key.**

- ☞ Factory-set chokes and pressure limiting devices may not be adjusted except by trained technical staff.
- ☞ Removing the seals from safety valves is prohibited.



### WARNING:

**Before performing any electric arc welding, always unplug the cables from the control cabinet and disconnect the battery.  
To disconnect the battery, undo the positive and negative terminal connections or switch off the Nato switch at the battery if this is fitted.**

- ☞ Disconnect machines with electrical equipment such as radio remote control (receiver), controls etc. before performing electric arc welding.
- ☞ Modifications, welding and repair work on the distributor boom and all assemblies associated with it, load-bearing elements, securing points, outriggers, on the mounting frame and any part of the pump or pressure-bearing components may only be performed by persons appointed by the manufacturer. Special care must be taken in respect of boom mountings and outriggers used as hydraulic or diesel tanks.
- ☞ When replacing electrical, pneumatic or hydraulic components (valves, pumps etc.), the required data (pressure, voltage etc.) should be checked from the machine data sheet, test sheet or circuit diagram and adjusted as necessary.
- ☞ Maintenance and repair work may be carried out only after fluids have been depressurised. No changes of any sort to the hydraulics are permissible. We emphatically warn against improper repairs to hydraulics. Test certificates supplied with hydraulic components should be carefully filed away for reference.
- ☞ If any component is removed, carefully note how it was fitted and replace it correctly referring to the spare parts data sheet / service information.

## 2.12 High-tension overhead electric cables

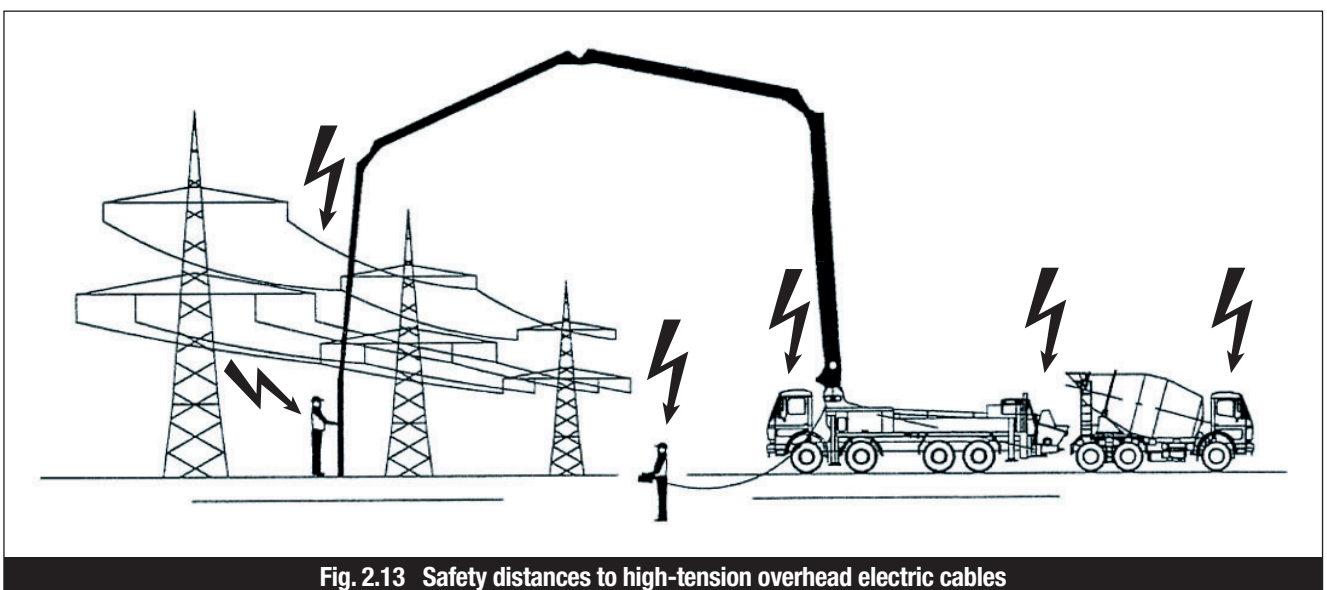

Fig. 2.13 Safety distances to high-tension overhead electric cables



### **DANGER:**

- ☞ **Direct contact with high-tension cables can cause fatalities.**
- ☞ **Even coming close to high-tension overhead electric cables can cause the machine and the surrounding ground to become live due to a flashover.**
- ☞ **Always maintain the stated safety distance.**



### 2.12.1 Safety distance

- ☞ The machine operator must ensure that when moving the distributor boom the clearances to overhead electric cables are maintained as set out in the table. The following minimum safety distances are those specified for the German Federal Republic in VDE 0105:

Nominal voltage	Minimum safety distance
up to 1.000 Volt	1,0 metre
over 1 kV bis 110 kV	3,0 metre
over 110 kV bis 220 kV	4,0 metre
over 220 kV bis 380 kV	5,0 metre
if the voltage is not known	5,0 metre

**Fig. 2.14 Minimum safety distance from overhead electric cables**

- ☞ If the minimum safety distance from overhead electric cables shown in the table cannot be maintained, the machine operator must ensure that they are
  - switched off for the duration of the work, or
  - they are shrouded or insulated in the vicinity of the concrete pump and distribution boom.
- ☞ The same minimum safe distances apply to driving underneath overhead electric cables. Make allowance for the swing of the cables and the distributor boom in the wind. High ambient humidities require safety distances greater than those listed. Refer to the regulations for the country where the machine is in use.



- ☞ If the minimum distance cannot be maintained for all possible working positions, it is essential to contact the electricity supply company.  
It may be necessary to forgo the use of the distributor boom altogether and use a separate conveyor pipe.

### 2.12.2 High-tension contacts

- ☞ High-tension contacts bring the risk of fatal injury for all persons who are on the machine and in its vicinity or are in any way connected to it (remote control, discharge hose etc.).
- ☞ High-tension contacts form a “Voltage funnel” underneath the equipment and in a circle around it. The voltage decreases as the radius increases.
- ☞ Every step within the voltage funnel is hazardous.  
A step can span two different potentials (step voltage), so that the current flows through the body in proportion to the potential difference.
- ☞ If a high-tension contact occurs, keep calm, stand still (step voltage), and don't touch anything.
- ☞ No-one else should enter the hazard area. Immediately have the high-tension cable switched off.
- ☞ After the high-tension cable has been switched off, move the machine away, help the injured and perform first aid.
- ☞ Using remote control protects the machine operator only if he is standing outside the voltage funnel.  
In all other cases all personnel risk fatal injury.
- ☞ When working close to high-tension overhead cables, have these switched off by competent electricians.

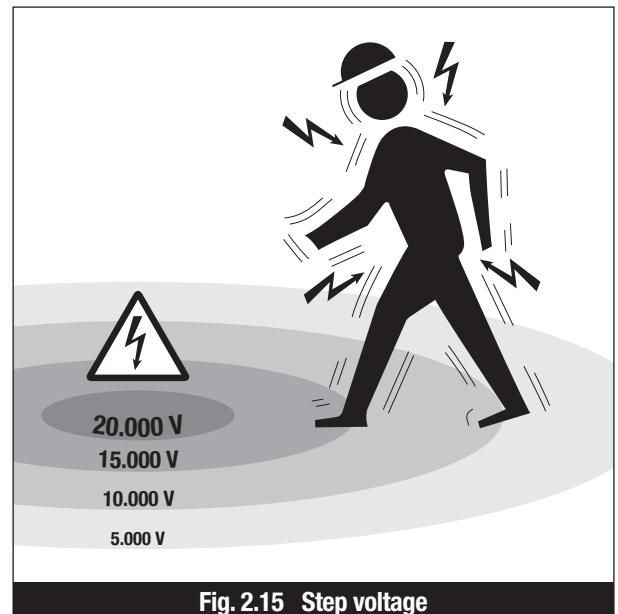

#### 2.12.2.1 Automatic reconnection

- ☞ Electrical supply systems are equipped with automatic reconnection.
- ☞ After the switchgear has tripped, the short-circuited cable is automatically reconnected after a brief interval.
- ☞ It is therefore necessary to arrange permanent disconnection.



### 2.12.3 Static discharge

- ☞ At close range to transmitting stations there can arise interference to radio and TV transmissions and hazardous static electrical discharges from the machine.
- ☞ Persons touching a statically charged machine will receive an electric shock.
- ☞ Machines close to transmitting stations should be earthed. Connect the earthing cable to a clean unpainted metal part of the machine, and anchor it in the ground with a conductive metal rod.

### 2.12.4 Immediate measures

- ☞ If an accident involving electric power occurs, immediately institute first aid measures.
- ☞ If despite all precautions a high-tension cable contact occurs, keep calm, stand still (step voltage), and don't touch anything.
- ☞ Tell those around to keep their distance (step voltage) and have the high-tension cable switched off.
- ☞ Only then can the machine be moved and the injured be assisted.

#### 2.12.4.1 Actions after contacting a high-tension overhead cable

- ☞ Stay in the machine
- ☞ Drive the machine out of the hazard area
- ☞ Warn those standing around to keep away and not to touch the machine
- ☞ Have the high-tension cable switched off
- ☞ Do not leave the machine until the high-tension cable that was contacted / damaged has been switched off

### 2.13 Operation in winter

When operating in winter, take care:

- ☞ Increased danger of slipping, especial when cleaning
- ☞ Keep steps and platforms free of snow and ice
- ☞ Risk of blockages due to ice in the conveying pipe



## 2.14 Storms and thunderstorms

- ☞ From wind force 7 (wind speed 50 km/h), stop work and move the distributor boom to the transport position.
- ☞ During thunderstorms there is a risk of lightning strikes.

## 2.15 Noise emission measurement

The noise emission measurement to EN/ISO 3744 and EN/ISO 4871 have yielded a value of  $L_{Aeq} = 81.4$  dB(A).

## 2.16 Environmental protection

- ☞ Use should be found around the building site for surplus concrete, or it should be disposed of as building waste according to the statutory requirements.
- ☞ Consumables such as lubricants, cleaning materials during maintenance, repair and oil change should be collected in suitable containers and disposed of in accordance with regulations (to EC directive 75/439/EWG and statutory instruments under §§ 5a, 5b AbfG and Altöl).

## 2.17 First aid

- ☞ Information should be sought for treatment of injuries that may arise when working with the truck-mounted concrete pump.
- ☞ Injuries must be reported to the supervisor.



## **2.18 Responsible persons**

### **2.18.1 Personnel**

The user must ensure that only personnel who have been properly trained and instructed work on or with the machine. The persons responsible for operation and maintenance must be clearly established. Furthermore he must ensure that only authorised persons use the machine.

### **2.18.2 Requirements**

The following requirements apply to all personnel concerned with operation and maintenance of the machine:

- ☞ They must be at least 18 years of age
- ☞ They must have appropriate physical and mental capabilities
- ☞ They must be in good health (calm and not under the influence of alcohol, drugs or medicines)
- ☞ They must have been trained in the operation and maintenance of the machine
- ☞ They must have proved their capability to the user
- ☞ They must be expected to fulfil their duties reliably

Personnel must not wear any loose clothing or jewellery, including rings.  
Free long hair must be secured using a hair net. This is an injury hazard since it may get caught or pulled in.

### **2.18.3 Skills**

Personnel who are being trained, taught, instructed or educated on the machine may use it only under continuous supervision of an experienced operator.

If no skilled personnel or workshop equipment etc. are available, apply to **WAITZINGER** Customer Service for maintenance of your machine.

### **2.18.4 Machine operator's responsibilities**

The user must make clear the machine operator's responsibilities (including national regulations for driving on public roads) and enable him to refuse instructions from third parties to commit unsafe actions. The machine operator must be permitted to refuse to work at a location when there are technical safety problems.





### 2.19 Safety and warning notices

Safety and warning notices are attached to the truck-mounted concrete pump as listed below. All safety and warning notices are depicted below in more detail.

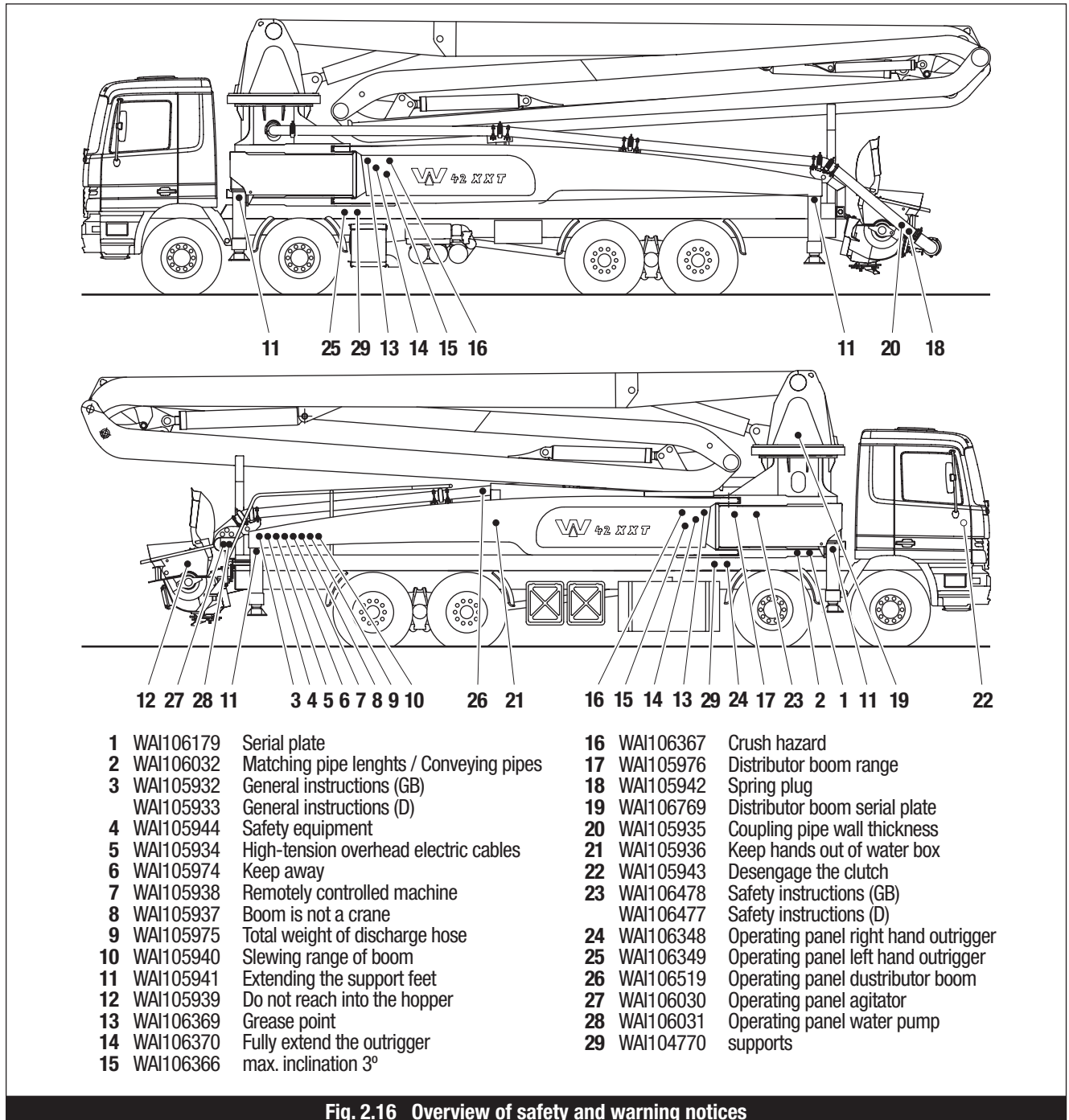

Fig. 2.16 Overview of safety and warning notices



		Waitzinger Baumaschinen GmbH Neu-Ulm / Germany			
Modell Model	<input type="text"/>	Zul. Gesamtgewicht (kg) Total weight perm. (kg)	<input type="text"/>		
Maschinen Nr. Masch.-No.	<input type="text"/>	Zul. Achslast (to.) Axle weight perm. (to.)	<input type="text"/>		
Baujahr Year of construction	<input type="text"/>	max. Abstützdruck (kp) max Outriggers press. (kp)	<input type="text"/>		
max. Hydraulikdruck max. Hydr. pressure	<input type="text"/>	max. Betondruck (bar) max. Concrete press. (bar)	<input type="text"/>		
V max. (km/h)	<input type="text"/>	max. Drehzahl max. rpm	<input type="text"/>		
<b>WAI106179</b>					

**Fig. 2.17 Item 1 - WAI106179 - Serial plate**

<b>Paßrohrängen / Förderleitung</b> <b>Delivery line / fitting pipe</b>					
max. Rohrgewicht max. weight pipe	<input type="text"/>	kg/m	Rohr Arm 1 pipe boom 1	<input type="text"/>	mm
max. Gewicht Förderbogen max. weight elbow	<input type="text"/>	kg	Rohr Arm 2 pipe boom 2	<input type="text"/>	mm
Rohr Podest pipe decking	<input type="text"/>	mm	Rohr Arm 3 pipe boom 3	<input type="text"/>	mm
Rohr Turm pipe tower	<input type="text"/>	mm	Rohr Arm 4 pipe boom 4	<input type="text"/>	mm
Rohr pipe	<input type="text"/>	<input type="text"/>	mm	Rohr Arm pipe boom	<input type="text"/>
<b>WAI106032</b>					

**Fig. 2.18 Item 2 - WAI106032 - Matching pipe lengths / Conveying pipes**



**WAITZINGER CONCRETE PUMP**

**GENERAL HINTS FOR OPERATION OF CONCRETE PUMPS**

The pump operator has to know the Operation and Maintenance Manual. He also has to know all safety regulations, which are important for the operating of a concrete pump and he has to keep them. He must be able to control the machine.

- 1. Before setting the machine into operation**
  - Make the working- and danger area safe, block it off if necessary.
  - Fill all operating fluids (hydraulic oil, fuel, water).
  - Check all safety devices (emergency stops) and control units of the Concrete Pump.
  - Lubricate all grease points and check the automatic lubrication system.
  - Check the stability of the machine.
  - Check the concrete pipes, if the piping is made carefully and regarding the wear out. (wall thickness test)
- 2. During Operation**
  - Do not let the machine run without observation.
  - Stop the machine at once, if any troubles occur which endanger the safety.
  - At concrete blocking inside the concrete pipeline, you have to suck the concrete back into hopper, and mix it with the agitator. Start pumping very carefully and slowly.
  - Do not open snap couplings at the concrete pipeline, if they are under pressure.
  - Protect your eyes against splashing concrete, especially during opening of concrete pipes.
  - Do not grab in or on moving parts. First stop engine and release the accumulator pressure.
  - Do not do any modifications regarding safety devices.
- 3. After Operation**
  - Empty the concrete pipes by suction.
  - Cleaning of concrete pipes with cleaning sponge and water.
  - Cleaning of hopper and the complete machine.
  - Carry out the daily maintenance and all repair work, which is necessary after working.

Waitzinger Baumaschinen GmbH · D-89231 Neu-Ulm

**WAI 105932**

**ETONPUMPE**

**ISE R BETONPUMPE**

ungsanleitung und alle etonpumpe kennen und

Is notwendig absperren. (raftstoff, Wasser). erheits- und

üfen der Schmieranlage

egung und

ingen auftreten, die eine Trichter zurückgefördert

öffnen, wenn die

nspritzern schützen. otor abschalten und

tsvorkehrungen

vornehmen.

- 3. Nach dem Betrieb**
  - Leersaugen der Förderleitung.
  - Reinigen der Förderleitung mit Reinigungsball und Wasser.
  - Reinigen des Trichters und der kompletten Maschine.
  - Durchführen von Wartungsarbeiten und Reparaturen, die während des Betriebes angefallen sind.

Waitzinger Baumaschinen GmbH · D-89231 Neu-Ulm

**WAI 105933**

**Fig. 2.19 Item 3 - WAI105933/WAI105932 - General instructions (GB/D)**

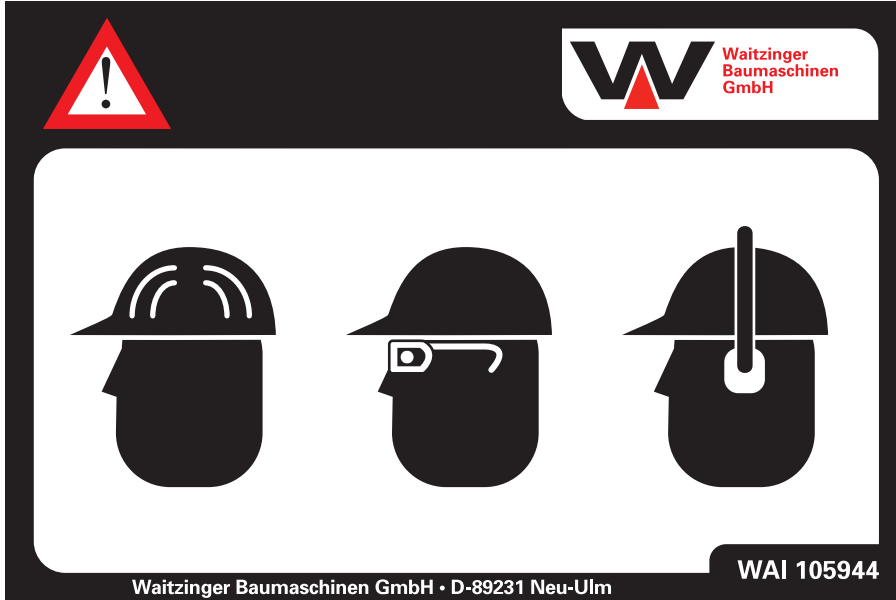

Fig. 2.20 Item 4 - WAI105944 - Safety equipment

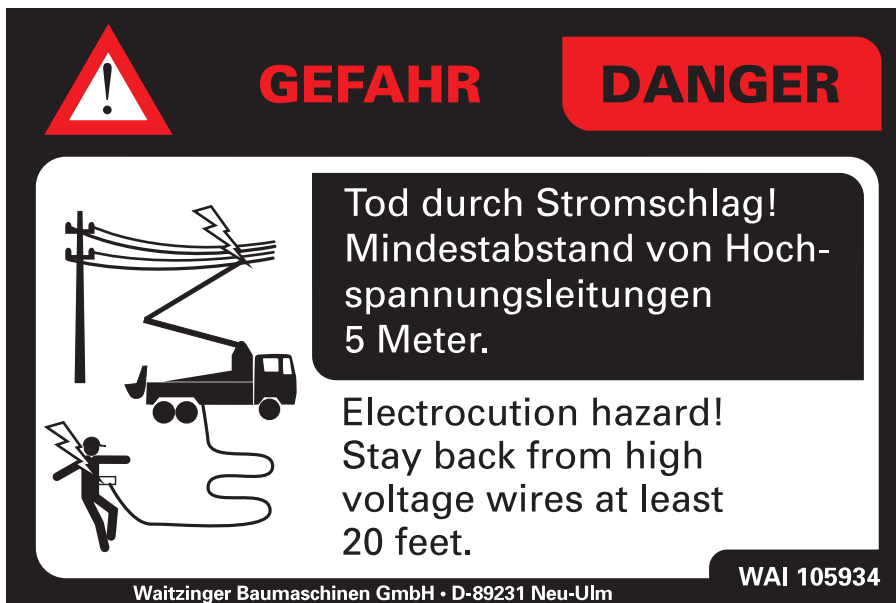

Fig. 2.21 Item 5 - WAI105934 - High-tension overhead electric cables





**GEFAHR**

**DANGER**



**Abstand halten! Berührung kann den Tod oder schwere Verletzungen herbeiführen, falls die Maschine unter Strom steht.**

Stay clear. Contact will result in death or serious injury if the unit becomes electrically charged.

Waitzinger Baumaschinen GmbH · D-89231 Neu-Ulm

**WAI 105974**

Fig. 2.22 Item 6 - WAI105974 - Keep away



**ACHTUNG**

**WARNING**



**Diese Maschine ist ferngesteuert und kann zu jedem Zeitpunkt starten. Vor Reparaturarbeiten Motor stoppen.**

This machine is remote controlled and may start at any time. Stop engine before servicing unit.

Waitzinger Baumaschinen GmbH · D-89231 Neu-Ulm

**WAI 105938**

Abb. 2.23 Item 7 - WAI105938 - Remotely controlled machine



**ACHTUNG** **WARNING**

Mast nicht als Kran oder Aufzug benutzen.

Do not use the boom as a crane or hoist.

Waltzinger Baumaschinen GmbH • D-89231 Neu-Ulm

WAI 105937

Fig. 2.24 Item 8 - WAI105937 - Boom is not a crane

**ACHTUNG** **WARNING**

Gesamtgewicht von Endschlauch, Reduzierungen und Schalenkupplungen darf mit Beton 160 kg NICHT überschreiten.

Total weight of end hose, reducers and clamps, including concrete, must NOT exceed 350 pounds.

Waltzinger Baumaschinen GmbH • D-89231 Neu-Ulm

WAI 105975

Fig. 2.25 Item 9 - WAI105975 - Total weight of discharge hose



Fig. 2.26 Item 10 - WAI105940 - Slewing range of boom



Fig. 2.27 Item 11 - WAI105941 - Extending the support feet

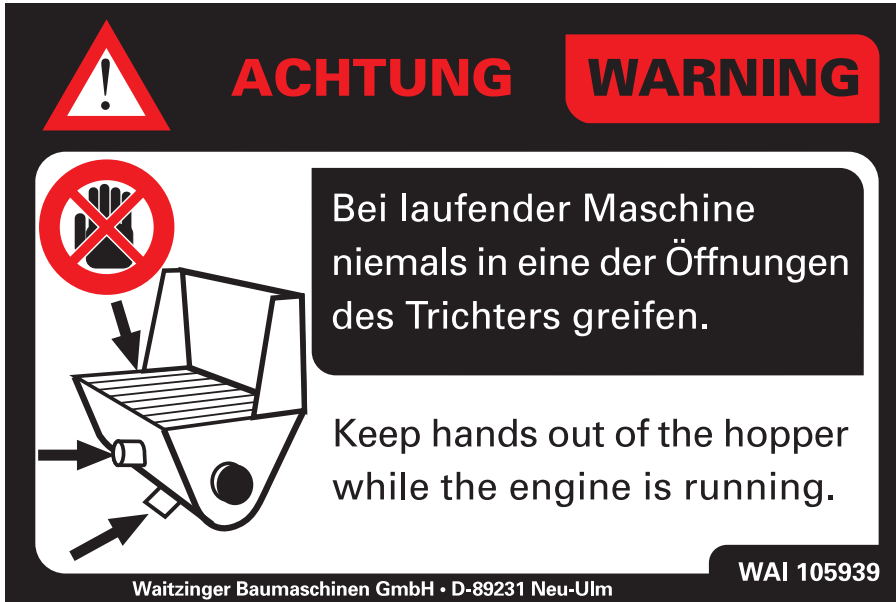

Fig. 2.28 Item 12 - WAI105939 - Do not reach into the hopper



Fig. 2.29 Item 13 - WAI106369 - Grease point

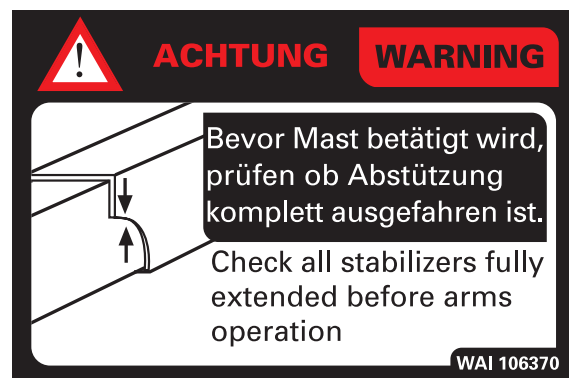

Fig. 2.30 Item 14 - WAI106370 - Fully extend the outrigger



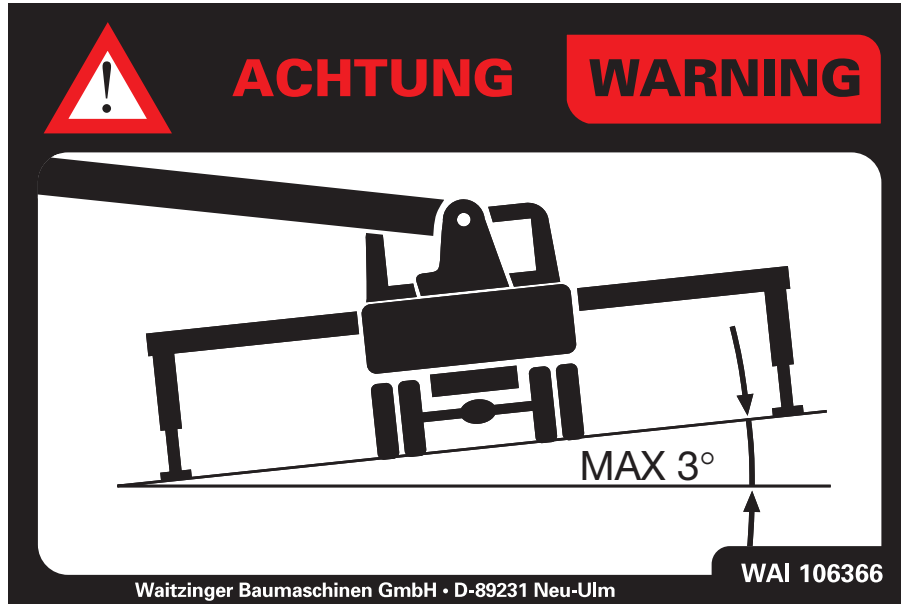

Fig. 2.31 Item 15 - WAI106366 - Max. inclination 3°



Fig. 2.32 Item 16 - WAI106367 - Crush hazard

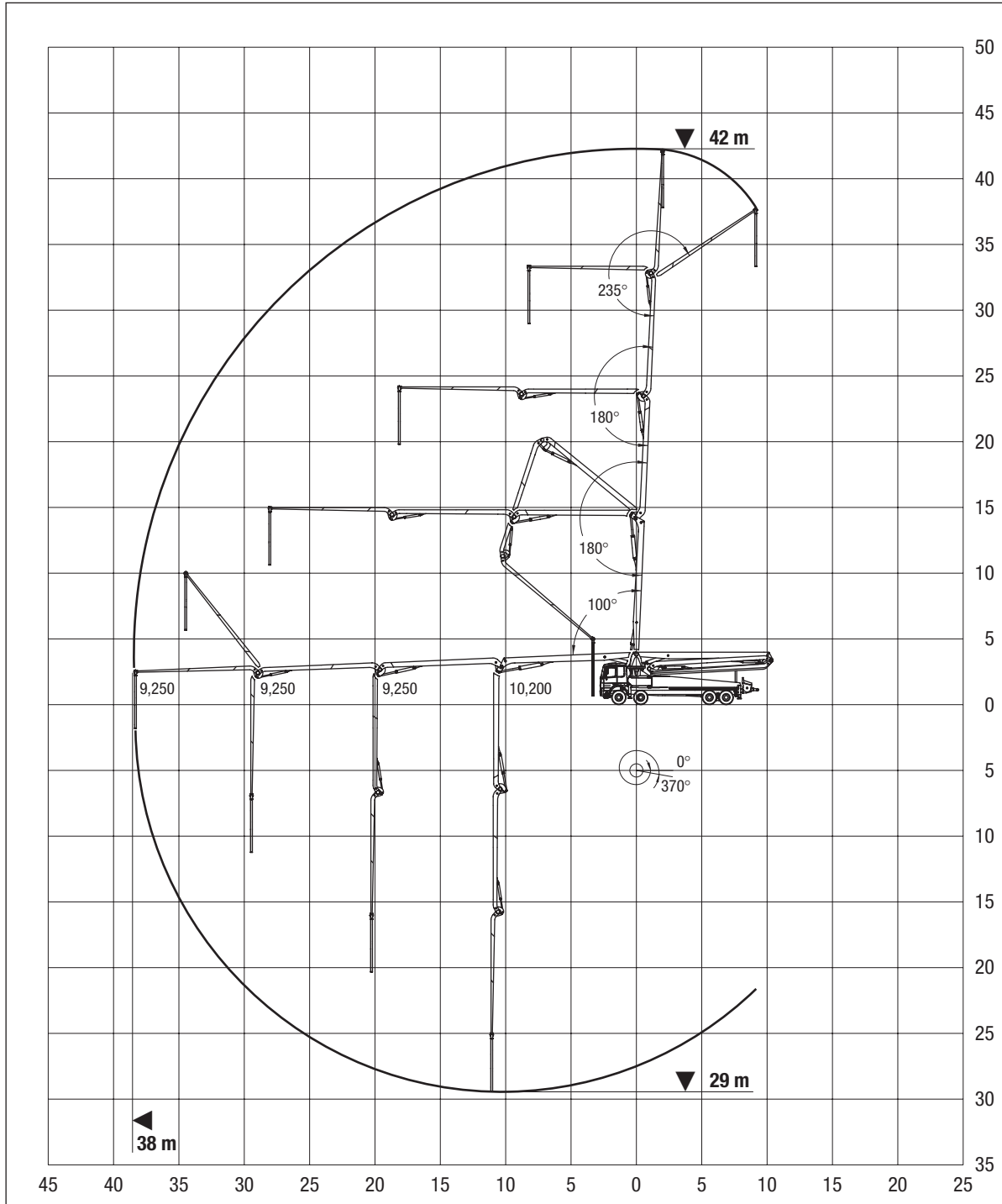

Fig. 2.33 Item 17 - WAI105976 - Distributor boom range



Fig. 2.34 Item 18 - WAI105942 - Spring plug

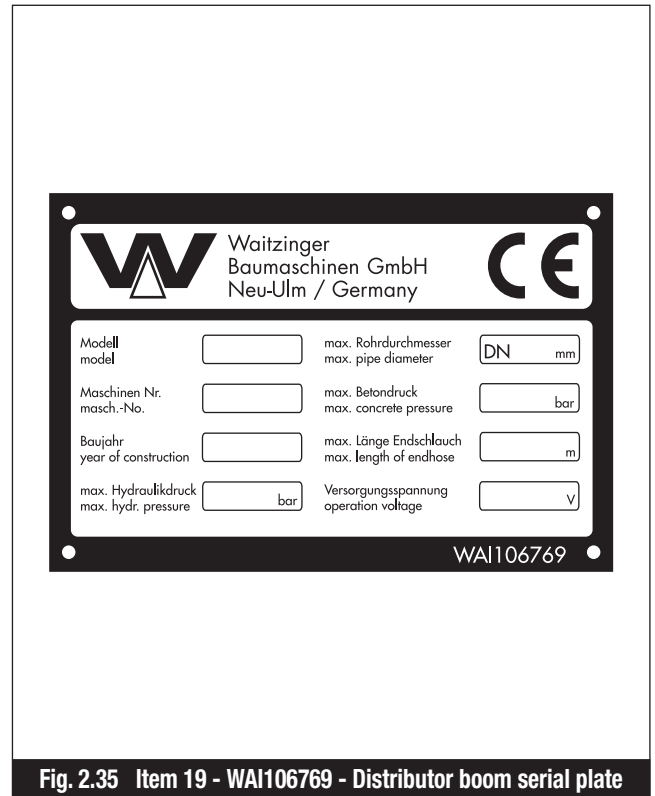

Fig. 2.35 Item 19 - WAI106769 - Distributor boom serial plate



Fig. 2.36 Item 20 - WAI105935 - Coupling pipe wall thickness



**ACHTUNG** **WARNING**

Hände nicht in den Wasserkasten/Trichter halten. Falls notwendig Motor stoppen. Unbeabsichtigtes Motorstarten verhindern.

Keep hands out of waterbox/hopper. Stop engine if access is required. Keep guards in place.

WAI 105936

Waitzinger Baumaschinen GmbH • D-89231 Neu-Ulm

Fig. 2.37 Item 21 - WAI105936 - Keep hands out of water box

**Nur den markierten Gang verwenden** **Use only the gear position with the mark**

1. Kupplung betätigen.  
2. Schalter auf "I" stellen.  
3. Gang einlegen und Kupplung lösen.

1. Press the clutch.  
2. Set switch to "I".  
3. Shift gear and release clutch.

WAI 105943

Waitzinger Baumaschinen GmbH • D-89231 Neu-Ulm

Fig. 2.38 Item 22 - WAI105943 - Disengage the clutch



### WAITZINGER CONCRETE PUMP

#### SAFETY OPERATING INSTRUCTIONS

1. Pump and boom operators must read and be familiar with the operator's manual before operating this equipment.
2. Safety devices must not be altered or removed.
3. If failures or malfunctions occur, stop operation and repair immediately.
4. Keep hands off from turning or moving machine parts.
5. If something happens to hinder the safe operation of this machine, halt use until corrected.
6. This machinery is remote controlled and may start at any time ! Stand clear.
7. If vision is obscured an assistant is required.
8. Ensure stability of unit, when in doubt of ground condition use extra blocking under outrigger legs. Operate unit on level ground.
9. Maintain safe distance from excavations. Slopes could break away.
10. Do not drive with an unfolded placing boom or unretracted outriggers.
11. Engage outrigger transport locking device before moving this machine.
12. No structural extension or additional hose should added to the boom tip selection. One tip hose 10-15 feet allowed unsupported. Additional hose and or line system require proper support of boom structure.
13. Do not use boom structure as crane, hoist or for lifting work. Use of the placing boom as a hoist is strictly prohibited.
14. Minimum distance to any electrical wires:
 

Voltage (Volt)	minimum safety distance (m)
up to 1000 V :	1m
over 1 kV to 380 kV or at unknown voltage and during high humidity :	5m
15. Boom should be folded / retracted upon completion of work and during high wind conditions. In storm conditions put boom in folded travel position.
16. Before opening any area of concrete pipeline depressurize system by reverse pumping. Then be cautious when opening couplings.
17. Only trained personnel should clean conveying pipeline with compressed air and water. A ball catcher or trap basket must be used at the discharge end.
18. Always wear approved safety helmet working around concrete pump unit. Full protective safety goggles to eliminate eye burns and damage are helpful.
19. Check machine once a year and document in checkbook, otherwise guaranty will expire.

WAI 106478

Waitzinger Baumaschinen GmbH • D-89231 Neu-Ulm

### BETONPUMPE

#### EISE

durch ausgebildete und  
 ner muß das Bedienungs-  
 ein.  
 deckt oder entfernt werden.  
 oder entfernt werden.  
 ernen.  
 le.  
 werden können, muß  
 erüstet und kann jederzeit  
 ernen.  
 itet sein. Je nach Untergrund  
 alken unterbaut werden.  
 en einhalten und Hohlräume  
 eilermast, bzw.  
 usschwanken gesichert sein.  
 hlauches ist verboten.  
 verwendet werden.  
 stand (m) \_\_\_\_\_  
 \_\_\_\_\_

15. Bei Sturm und nach Beendigung der Arbeit Maschine in Außer-Betrieb-Stellung bringen.
16. Bei Arbeiten an der Förderleitung muß sichergestellt werden, daß das System drucklos ist.
17. Nur Fachpersonal sollte die Förderleitung mit Wasser bzw. Druckluft reinigen. Auffangkorb für Reinigungsball muß montiert sein; Endschlauch entfernen.
18. Schutzhelm, Schutzbrille und Schutzkleidung müssen getragen werden.
19. Die Maschine ist mindestens einmal jährlich durch einen Sachkundigen zu prüfen und im Prüfbuch einzutragen, ansonsten erlischt der Garantieanspruch.

WAI 106477

Waitzinger Baumaschinen GmbH • D-89231 Neu-Ulm

**Fig. 2.39 Item 23 - WAI106477/WAI106478 - Safety instructions (GB/D)**

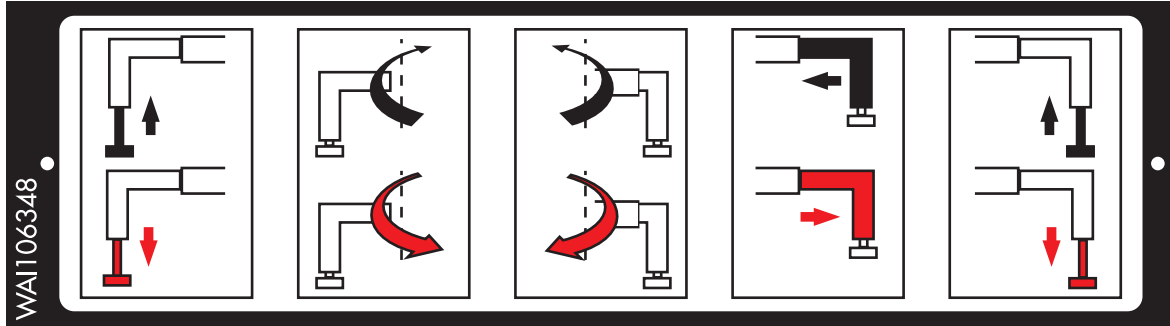

Fig. 2.40 Item 24 - WAI106348 - Operating panel right hand outrigger

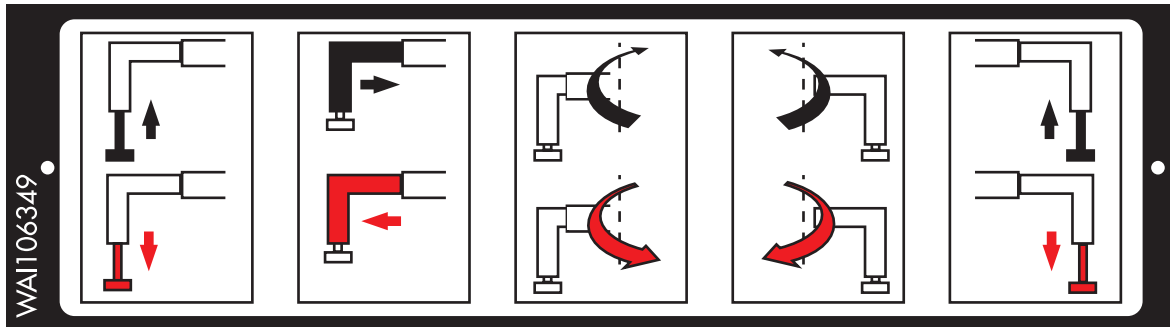

Fig. 2.41 Item 25 - WAI106349 - Operating panel left hand outrigger

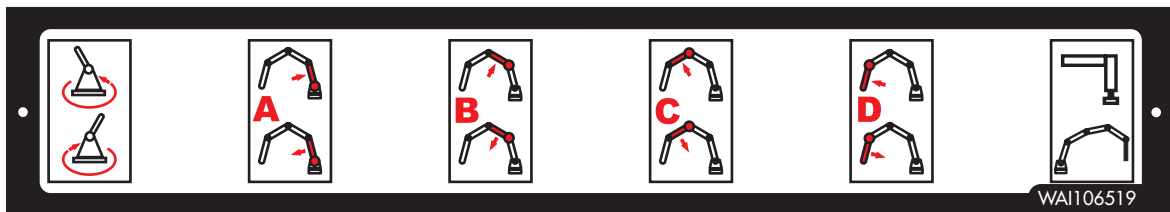

Fig. 2.42 Item 26 - WAI106519 - Operating panel distributor boom

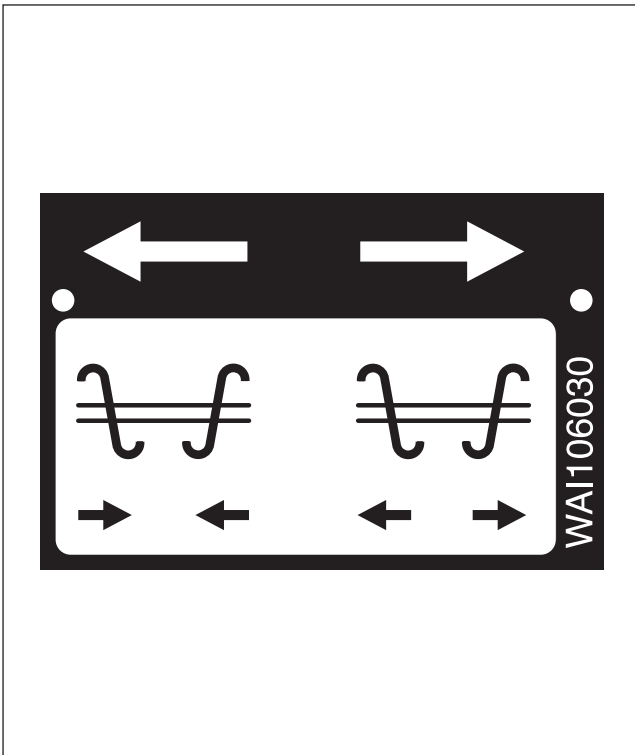

Fig. 2.43 Item 27 - WAI106030 - Operating panel agitator

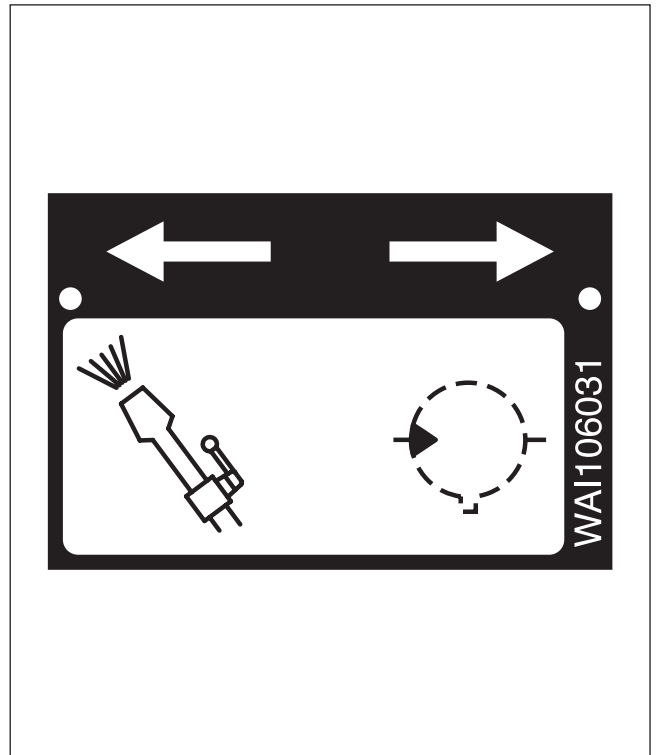

Fig. 2.44 Item 28 - WAI106031 - Operating panel water pump

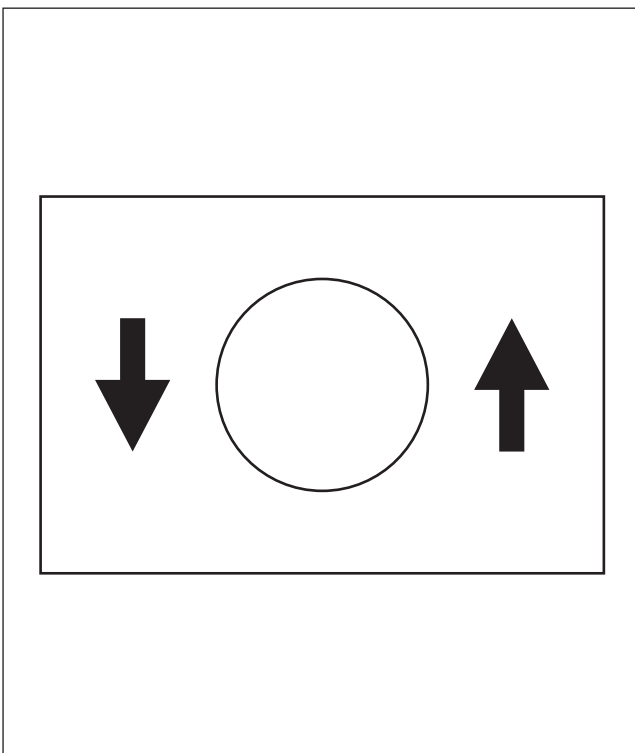

Fig. 2.45 Item 29 - WAI104770 - Operating panel supports







### 3. Technical data

#### 3.1 Leading dimensions of the truck-mounted concrete pump,

Vehicle dimensions approx. 13,070 mm x 2,500 mm x 3,980 mm  
(Length x Width x Height)

Weight approx. 31,900 kg  
(in full working order)

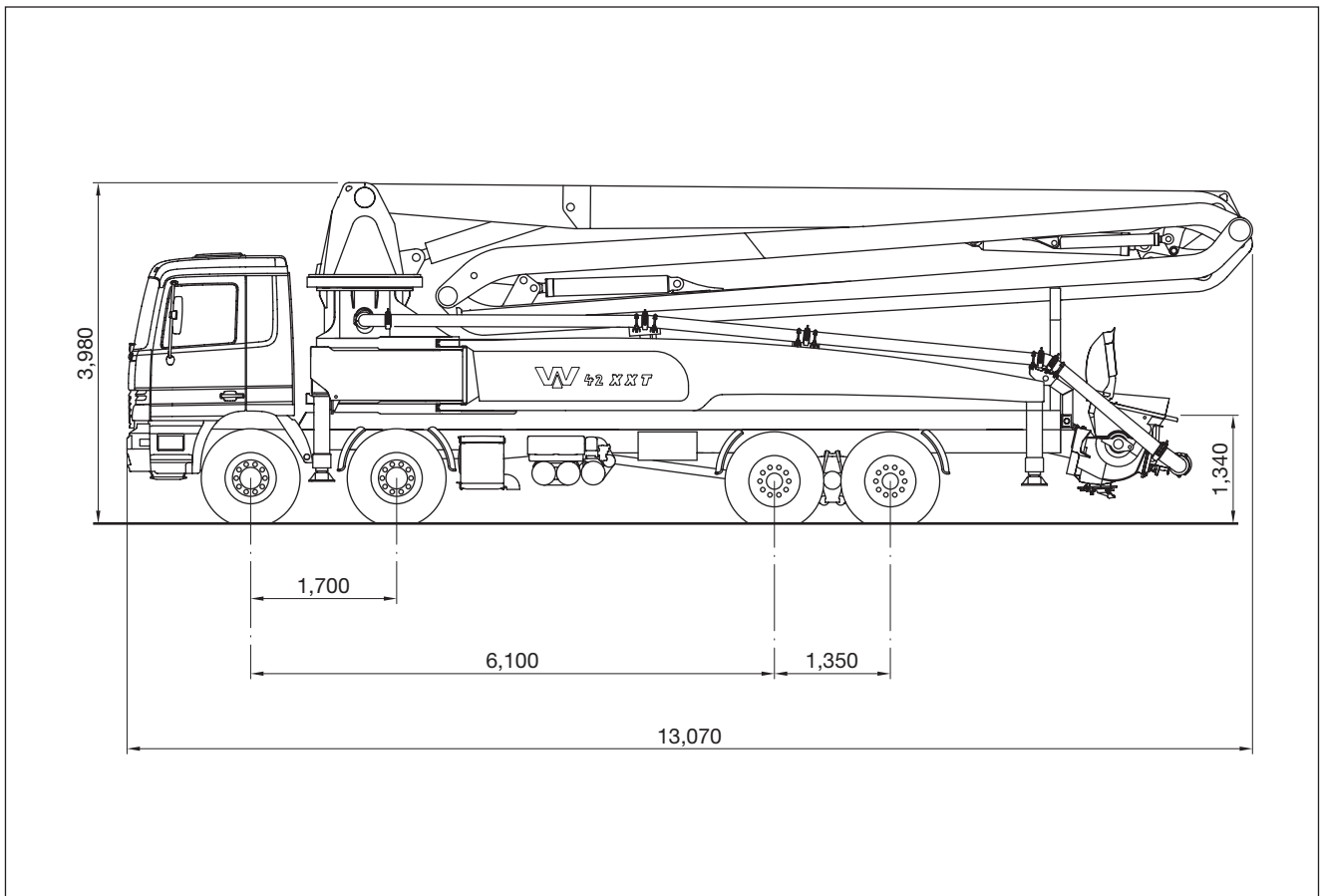

**Fig. 3.1 Leading dimensions of the truck-mounted concrete pump**

#### 3.2 Truck

Information regarding the truck can be found in the separate user manual supplied by the truck manufacturer.



### 3.3 Distributor boom 42 R 4 XXT

Horizontal reach	[mm]	38,000
Vertical reach	[mm]	42,000
Slewing range	[degrees °]	370
1 / A element rotation	[degrees °]	100
2 / B element rotation	[degrees °]	180
3 / C element rotation	[degrees °]	180
4 / D element rotation	[degrees °]	235
Concrete pipeline diameter	[mm]	125
Front outrigger setup	[mm]	8,500
Rear outrigger setup	[mm]	8,000
Length of discharge hose	[mm]	4,000
Voltage	[V]	12/24
Max. slope of ground	[degrees °]	3
Front outrigger pressure	[kN]	220
Rear outrigger pressure	[kN]	220
Max. concrete pressure	[bar]	85
Max. weight of pipework	[kg/m]	12
Max. weight of elbow	[kg]	13
Max. density of concrete	[kg/m <sup>3</sup> ]	2,4
Hydraulic pressure for distributor boom	[bar]	330
Hydraulic pressure for outriggers	[bar]	200
Secondary settings		
Element 1 up	[bar]	300
Element 2 up	[bar]	320
Element 3 up	[bar]	280
Element 4 up	[bar]	280
Rotate	[bar]	160
Telescopic extension	[bar]	100/100
Slew out front outrigger	[bar]	50
Slew in front outrigger	[bar]	80
Time element 1 up/down 100 °	[sec]	90
Time element 2 up/down 180 °	[sec]	115
Time element 3 up/down 180 °	[sec]	76
Time element 4 up/down 235 °	[sec]	51
Rotate left/right 370 °	[sec]	160

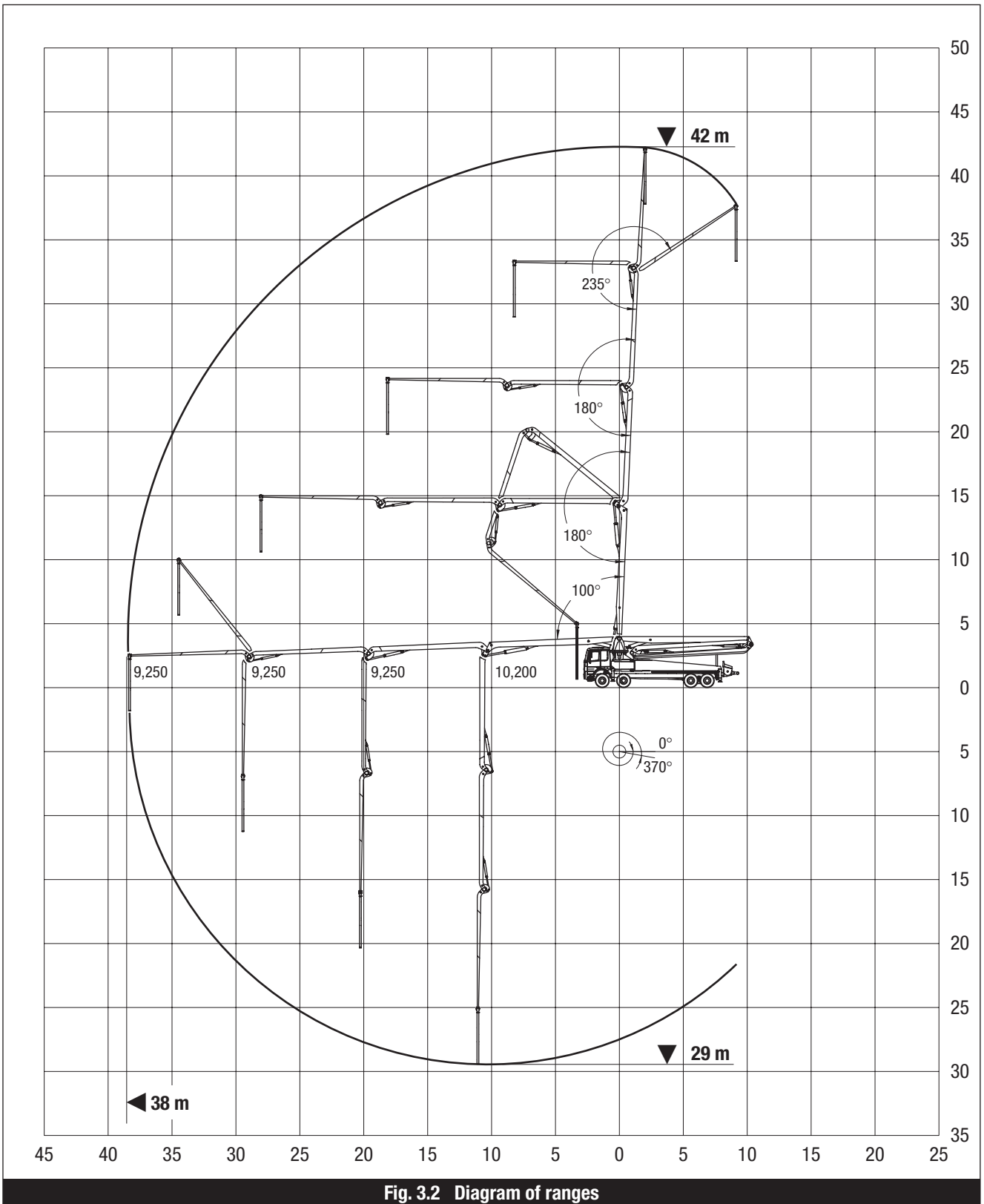

Fig. 3.2 Diagram of ranges



### 3.4 Concrete pump

	<b>94/42 R 4 XXT</b>	<b>125/42 R 4 XXT</b>	<b>140 H/42 R 4 XXT</b>
Max. concrete output, rod side	[m <sup>3</sup> /h] 94	125	140
Max. concrete output, piston side	[m <sup>3</sup> /h] 57	75	96
Max. concrete pressure, rod side	[bar] 75	55	80
Max. concrete pressure, piston side	[bar] 125	95	119
Pump cycles/min, rod side	25	25	28
Pump cycles/min, piston side	15	15	19
Conveying cylinder, D <sub>inner</sub> x stroke	[mm] 200 x 2,000	230 x 2,000	230 x 2,000
Stroke volume / double stroke	[litre] 125	166	166
Hydraulic drive cylinder, D <sub>piston</sub> /D <sub>rod</sub> x stroke	[mm] 125/80 x 2,000	125/80 x 2,000	140/80 x 2,000
Oil tank volume	[litre] 600	600	600
Water tank volume	[litre] 600	600	600
Hopper capacity	[litre] 600	600	600
Water pump pressure	[bar] 20	20	20
Max. hydraulic pressure, concrete pump	[bar] 320	320	320
Max. hydraulic pressure, agitator	[bar] 250	250	250
Max. hydraulic pressure, water pump	[bar] 250	250	250
Max. speed of cardan shaft	[rpm] 1.650	1.650	1.650

WARNING:  
Note transmission ratio from vehicle gearbox!



## **4. Description**

### **4.1 Proper use**

The truck-mounted concrete pump is a working machine and is exclusively intended for conveying concrete up a density in the pipe of 2,400 kg/m<sup>3</sup>.

The machine is not to be used for transport of goods other than transporting accessories such as pipes and hoses etc.

The maximum permissible total weight must not be exceeded.

Any use that is not covered by proper use is deemed to be improper use or misuse.  
**WAITZINGER** accepts no liability for damage that arises under such circumstances.

The truck-mounted concrete pump as delivered is in accordance with current technology and complies with recognised safety standards for construction and use.

The truck-mounted concrete pump should be operated only when it is in good technical condition and for its proper purpose.

The mandatory regulations for accident prevention applicable in the country and location of operation, and the recognised technical safety rules for safe and proper working practices, together with the instructions for operation and maintenance, must all be complied with.



## 4.2 Structure and function of the truck-mounted concrete pump

### 4.2.1 Structure of the truck-mounted concrete pump

The truck-mounted concrete pump comprises a concrete pump conveying unit mounted on a truck chassis.

The concrete pump conveying unit comprises the following major subassemblies:

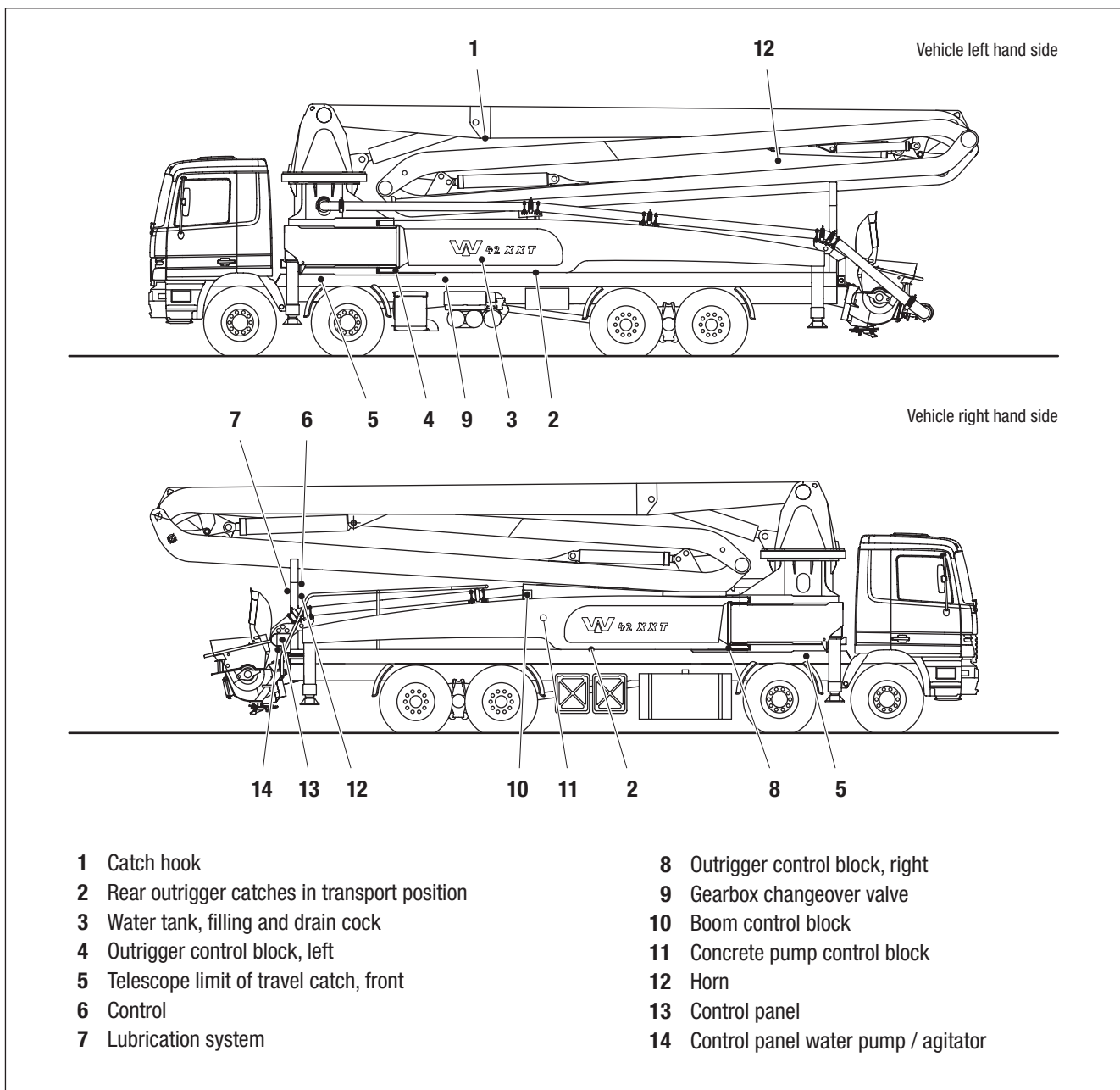

**Fig. 4.1 Main components of the truck-mounted concrete pump - sheet 1**

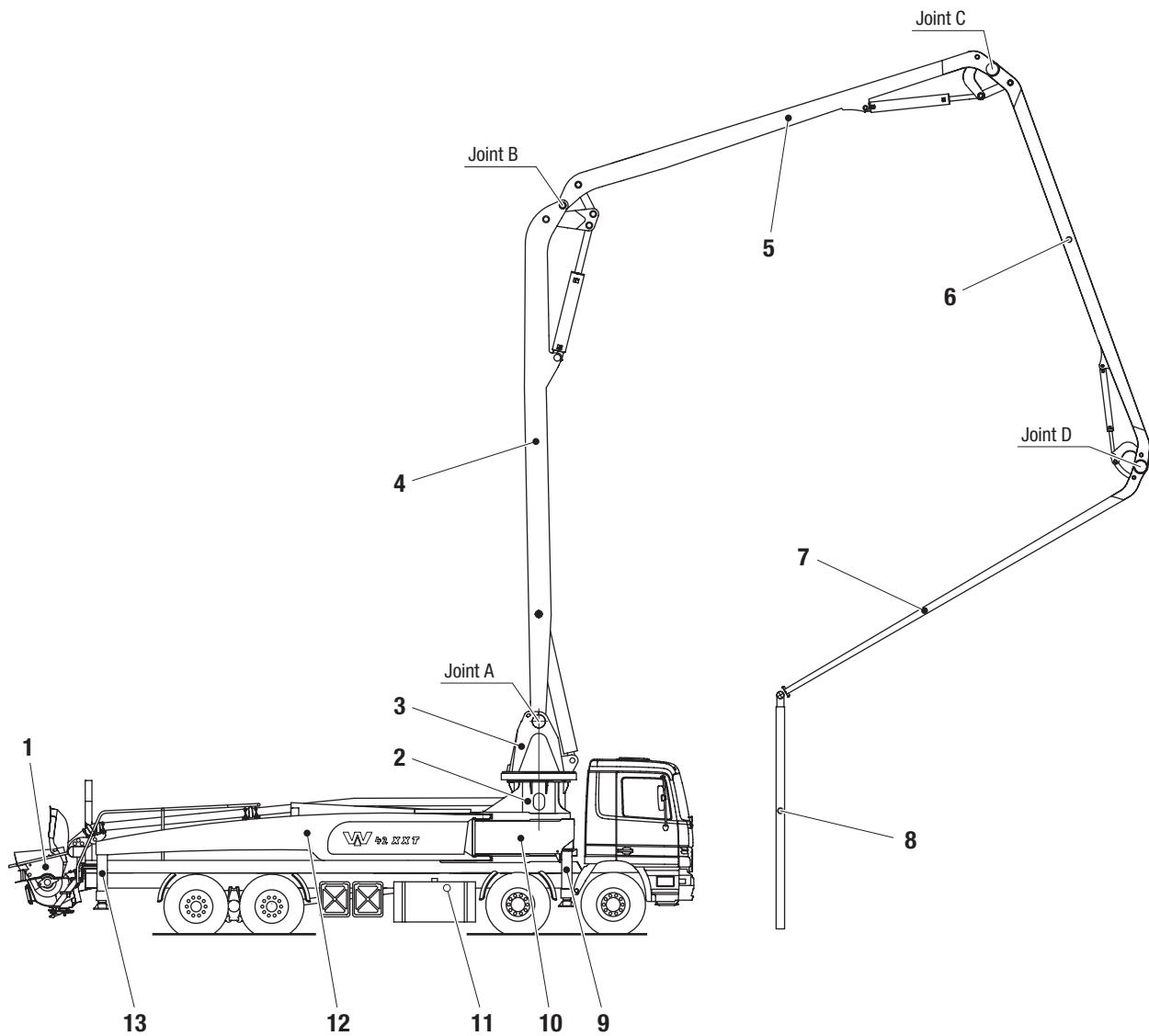

- |                  |                             |
|------------------|-----------------------------|
| 1 Pump group     | 8 Discharge hose            |
| 2 Boom block     | 9 Front outrigger cylinder  |
| 3 Slewing head   | 10 Front telescopic section |
| 4 Boom element A | 11 Transfer shift gearbox   |
| 5 Boom element B | 12 Rear outrigger           |
| 6 Boom element C | 13 Rear outrigger cylinder  |
| 7 Boom element D |                             |

**Fig. 4.2 Main components of the truck-mounted concrete pump - sheet 2**



## **4.2.2 Function of the truck-mounted concrete pump**

The concrete is delivered into the hopper and is pumped by the concrete pump through the S-valve and the conveying pipework to the discharge hose.

### **4.2.2.1 Distributor boom**

All distributor boom functions are hydraulically actuated.  
The conveying and riser pipes comprise pipes and pipe elbows.  
Snap couplings allow the pipes to be joined together and the joints to be rotated.

### **4.2.2.2 Outriggers**

The rear outriggers are swung out hydraulically. The telescopic front outriggers are hydraulically swung out and extended. The hydraulic support cylinders ensure the necessary stability of the truck-mounted concrete pump. The rear outriggers contain the water tanks with a capacity of 400 litres each.

### **4.2.2.3 Control**

The controls actuate the hydraulic systems for the concrete pump and distributor boom. The operator can use the controls either at the control panel or at the remote control pendant.

### **4.2.2.4 Central lubrication**

The central lubrication system is operated by compressed air from the pressure accumulator on the vehicle chassis. It supplies all lubrication points on the truck-mounted concrete pump (apart from the conveying piston). An optional central lubrication system is available for the conveying piston and/or distributor boom.





#### 4.2.2.5 Function of the concrete pump

The concrete pump is hydraulically driven by the vehicle engine through a transfer shift gearbox and hydraulic pump.

The controls are electric and fully automatic. In addition a back-up function can be engaged by a selection switch; this allows the concrete pump to continue to be run at a reduced speed should the control system or the sensors fail. The stroke rate can be varied between minimum and maximum.

The drive cylinders (1) are fitted with an automatic leakage compensation. The S-valve automatically compensates for wear at the wear plate and wear ring.

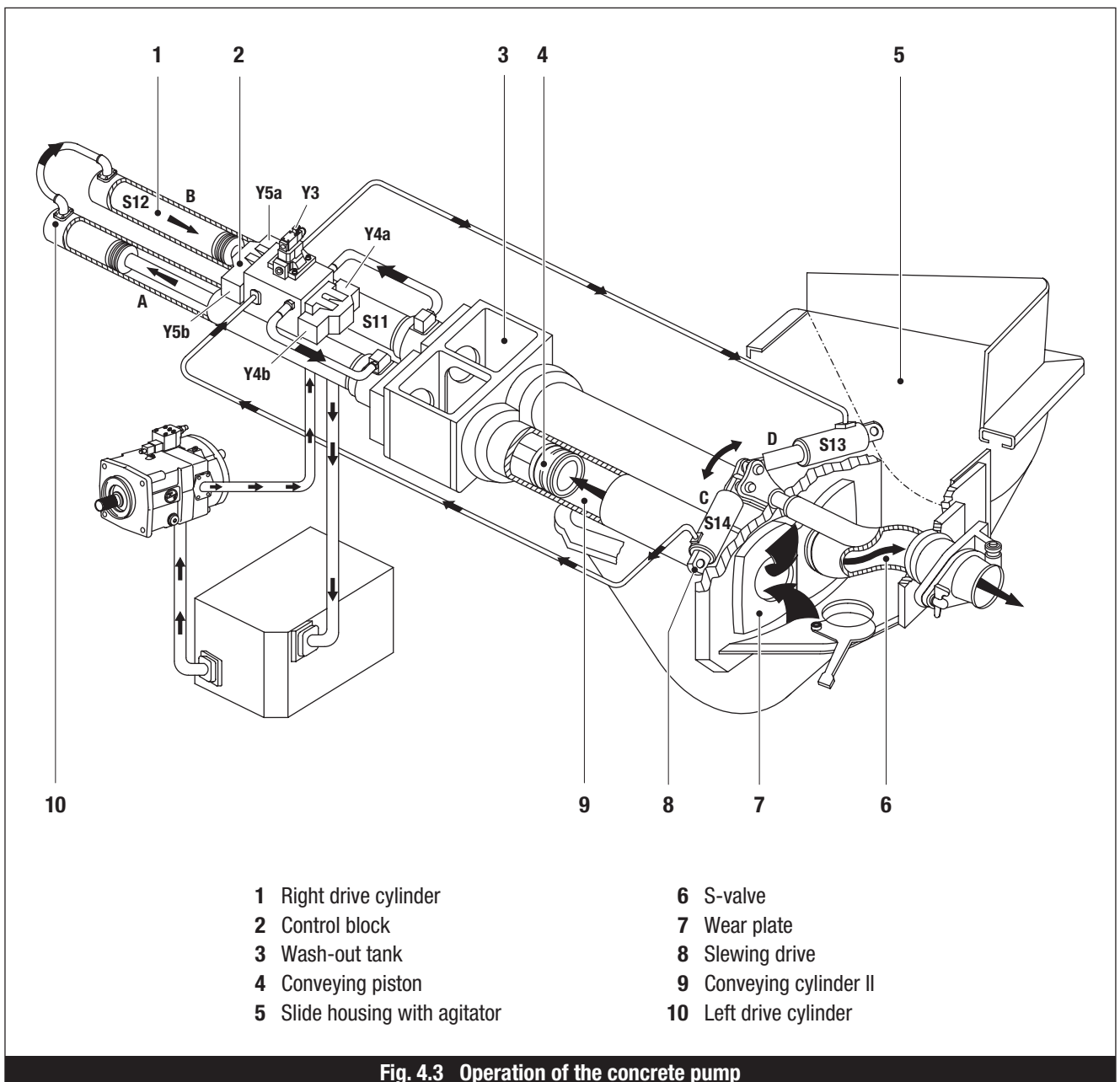

**Fig. 4.3 Operation of the concrete pump**



#### **4.2.2.6 Method of operation of the concrete pump**

*The concrete pump operates as follows:*

The oscillation cylinders are in position S13. On pumping the pressure relief valve Y3 is electrically actuated and closes, and Y4b is started. The drive cylinders move in direction "A". The concrete in the left hand conveying cylinder is pushed into the S-valve into the conveying pipe.

Concrete is sucked into the right hand conveying cylinder through the free opening in the hopper. As soon as sensor S12 trips, valves Y4b and Y5b are started. The drive cylinders remain stationary and the oscillation cylinders start to move in direction "C". The S-valve is now in line with the right hand conveying cylinder. Sensor S14 starts Y4a (and Y5b stops), and the drive cylinders move in direction "B". The right hand conveying piston now pushes concrete through the S-valve and the left cylinder sucks concrete in from the slide housing. Sensor S11 stops Y4a and Y5a swings the S-valve back in direction "D". A full cycle is now complete.



## 5. Controls and displays

### 5.1 Controls and displays for the truck-mounted concrete pump

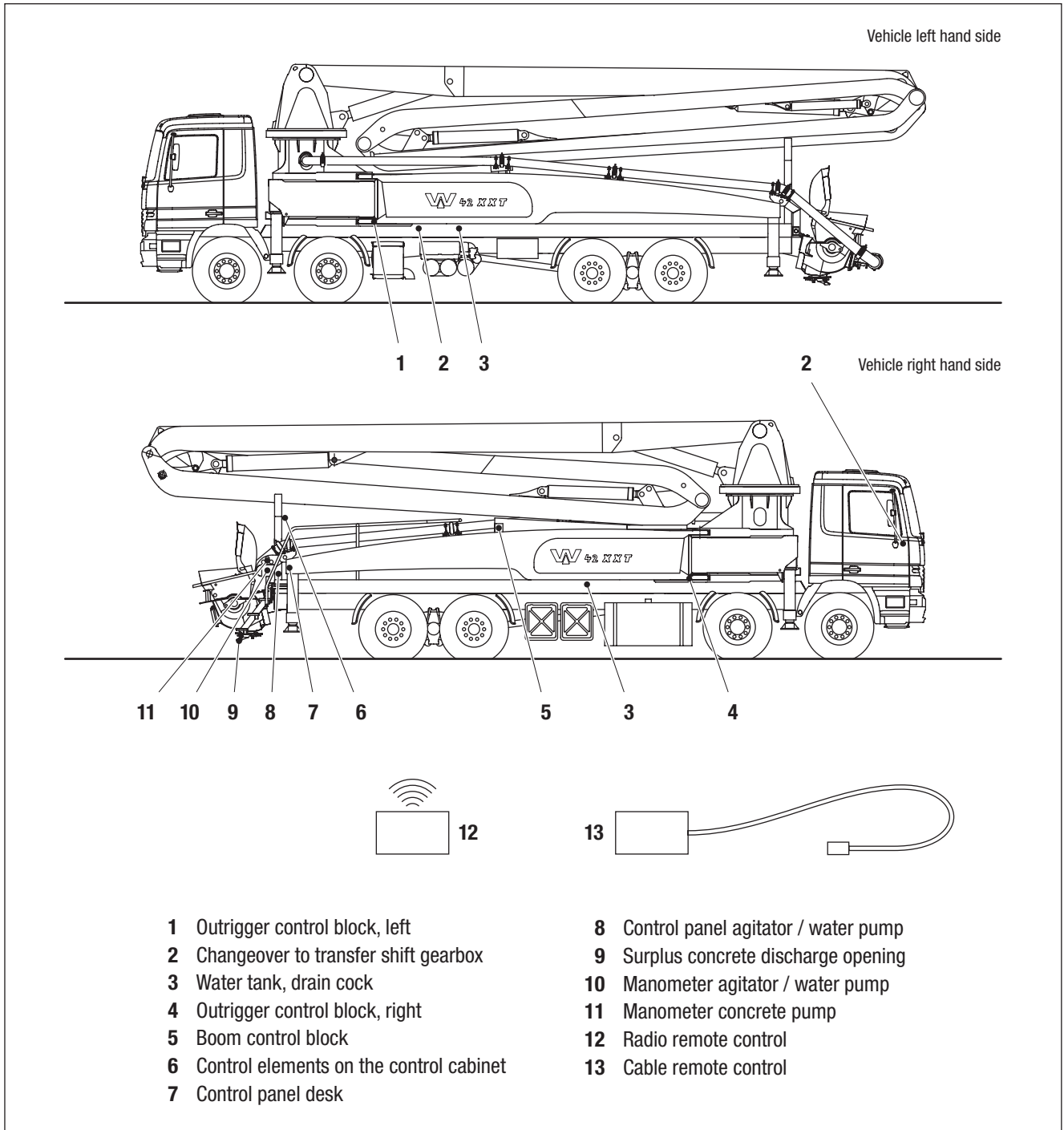

**Fig. 5.1 Controls and displays for the truck-mounted concrete pump**



### 5.2 Control panel desk



- |  |  |
|--|--|
| 1 Emergency Stop button                      | 8 Rocker switch "Vibrator Auto/Manual" |
| 2 Indicator lamp "Emergency Stop"            | 9 Rocker switch "Engine speed +/-"     |
| 3 Indicator lamp "Controls on"               | 10 Indicator lamp "Pumps"              |
| 4 Indicator lamp "Hydraulic oil temperature" | 11 Rocker switch "Pump/Suck"           |
| 5 Control panel lighting                     | 12 Indicator lamp "Suck"               |
| 6 Rocker switch "Horn-Reset/Lubrication"     | 13 Stroke rate potentiometer           |
| 7 Rocker switch "Light"                      | 14 Key switch "Desk/Remote control"    |

Fig. 5.2 Control panel desk



### 5.3 Control panel agitator / water pump

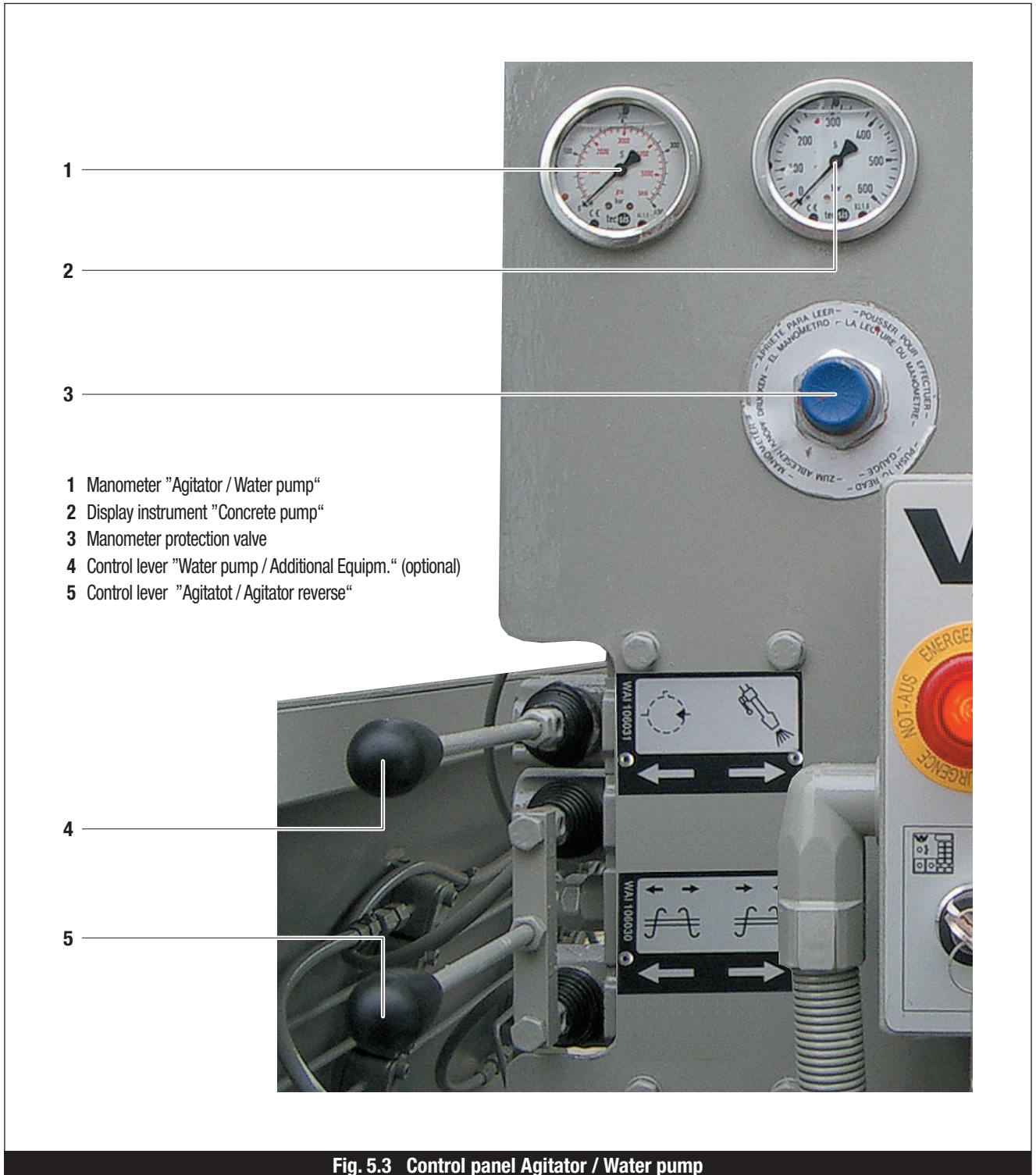



## 5.4 Boom control block

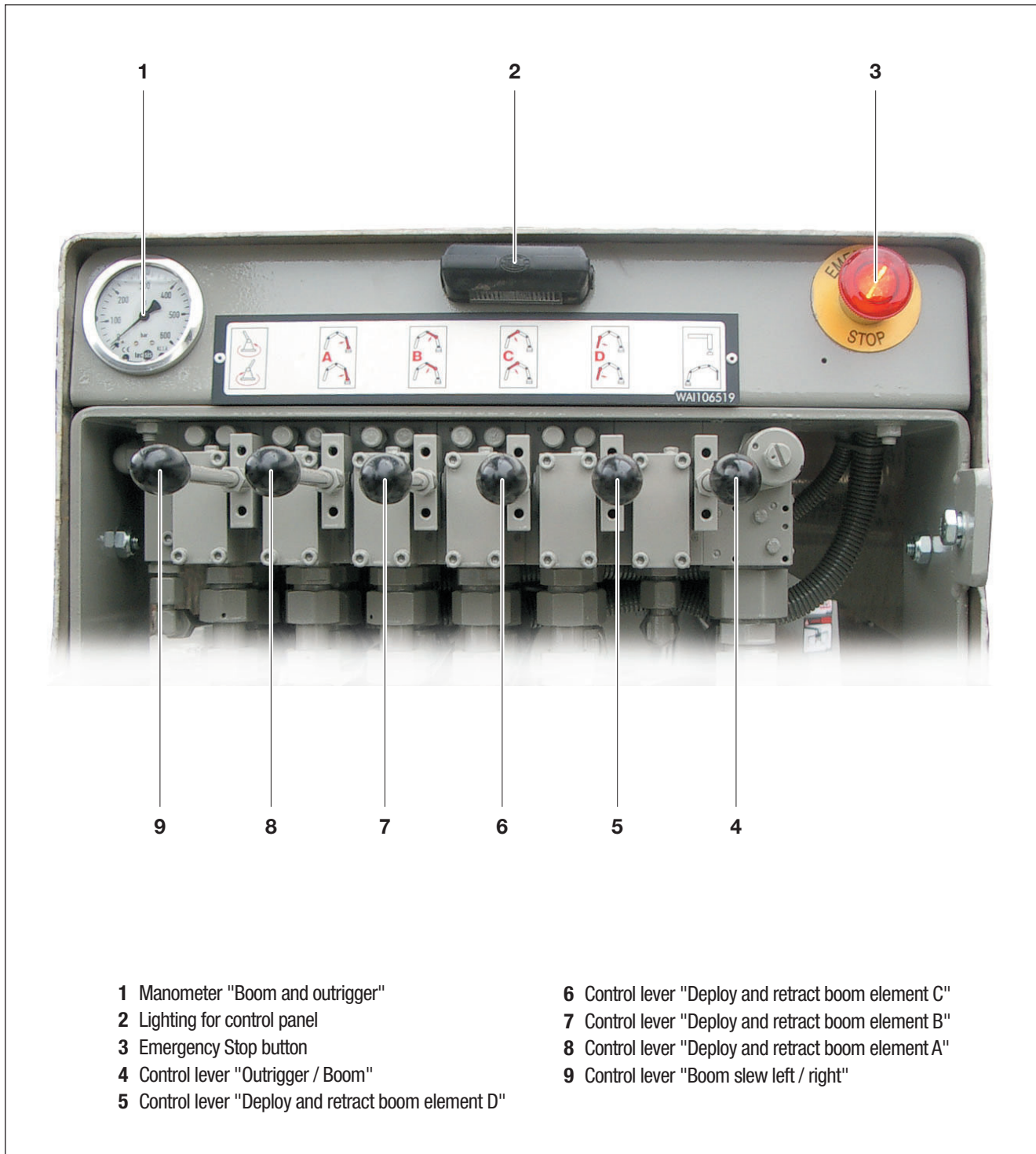

- |   |   |
|---|---|
| 1 Manometer "Boom and outrigger"                    | 6 Control lever "Deploy and retract boom element C" |
| 2 Lighting for control panel                        | 7 Control lever "Deploy and retract boom element B" |
| 3 Emergency Stop button                             | 8 Control lever "Deploy and retract boom element A" |
| 4 Control lever "Outrigger / Boom"                  | 9 Control lever "Boom slew left / right"            |
| 5 Control lever "Deploy and retract boom element D" |   |

**Fig. 5.4 Boom control panel**



## 5.5 Outrigger control block, left

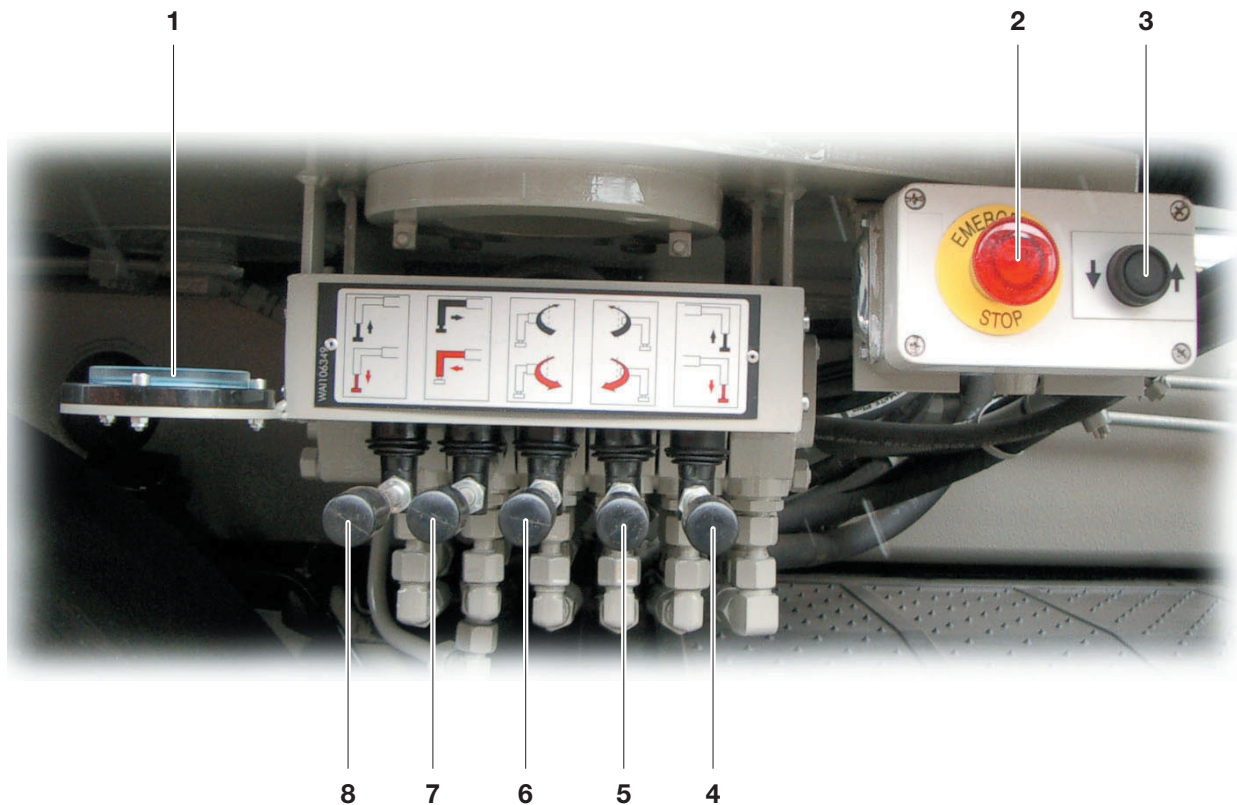

- 1 Circular level
- 2 Emergency Stop button
- 3 Outrigger safety button
- 4 Control lever "Extending / retracting the rear outrigger cylinder"
- 5 Control lever "Slewing the rear outrigger out / in"
- 6 Control lever "Slewing the front outrigger out / in"
- 7 Control lever "Extending / retracting the front outrigger telescope"
- 8 Control lever "Extending / retracting the front outrigger cylinder"

**Fig. 5.5 Left outrigger control panel**



## 5.6 Outrigger control block, right

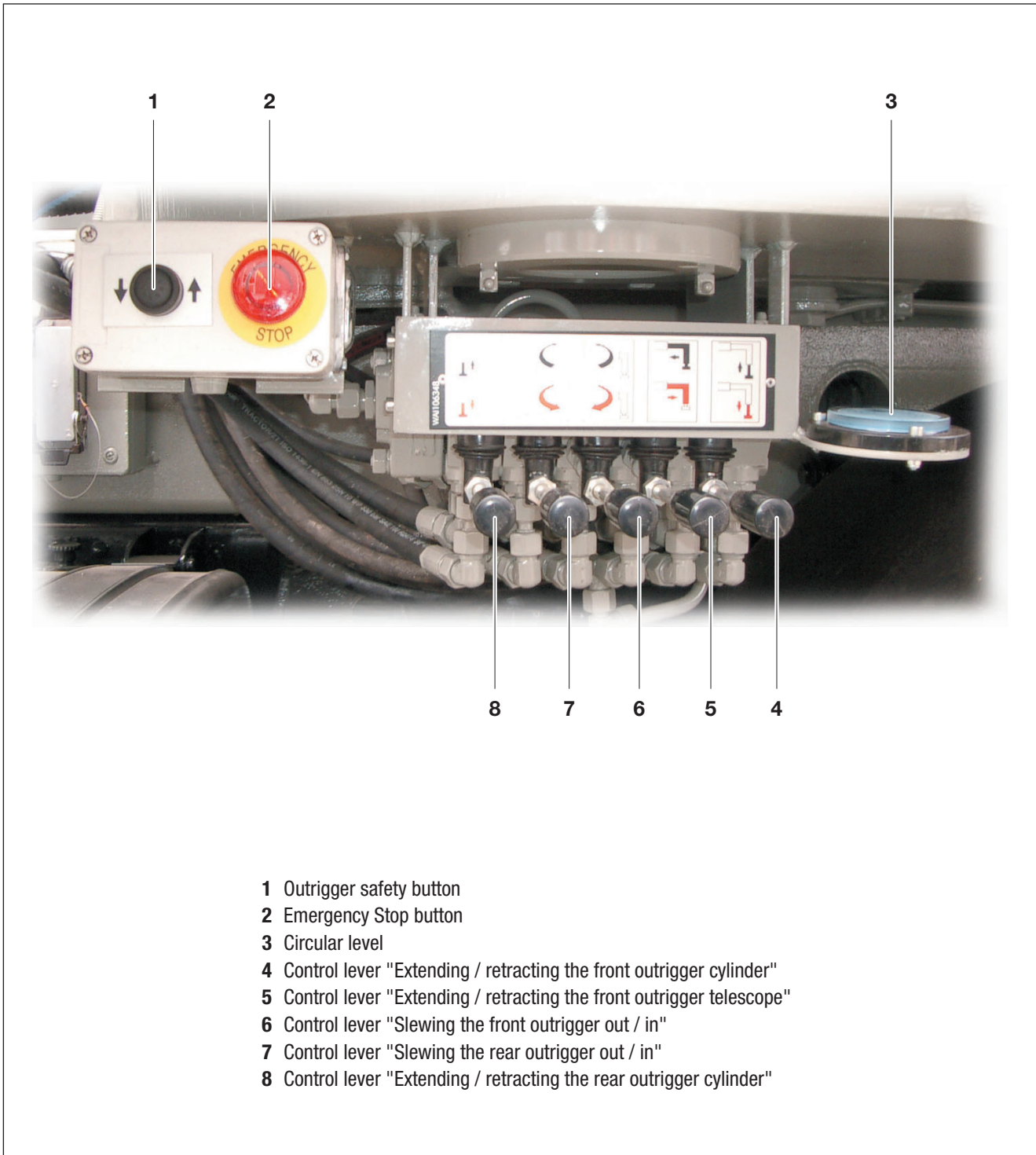

- 1 Outrigger safety button
- 2 Emergency Stop button
- 3 Circular level
- 4 Control lever "Extending / retracting the front outrigger cylinder"
- 5 Control lever "Extending / retracting the front outrigger telescope"
- 6 Control lever "Slewing the front outrigger out / in"
- 7 Control lever "Slewing the rear outrigger out / in"
- 8 Control lever "Extending / retracting the rear outrigger cylinder"

**Fig. 5.6 Right outrigger control panel**





## 5.7 Control cabinet

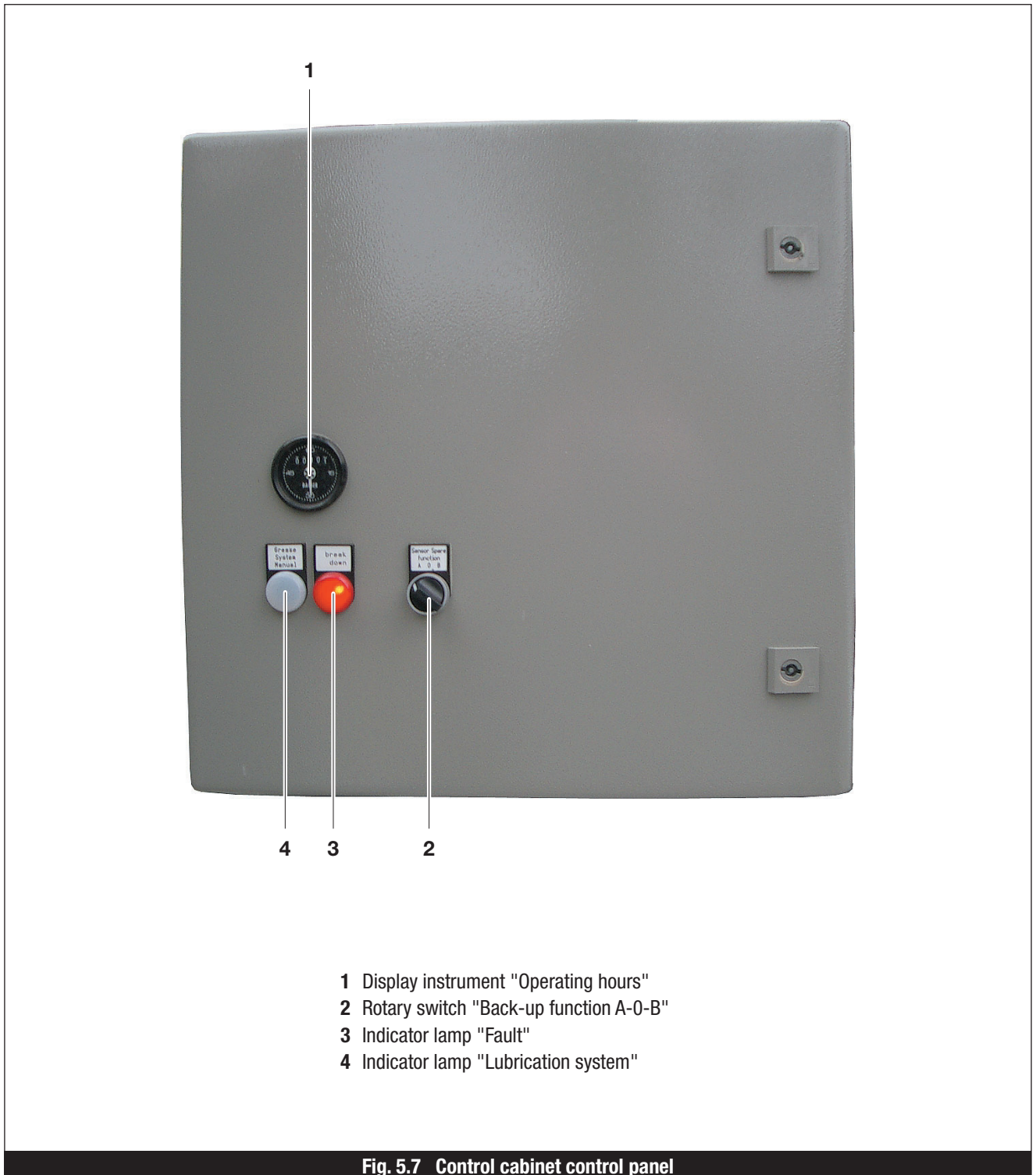



## 5.8 Changeover to transfer shift gearbox (in the cab)

- 1 Indicator lamp "Transfer shift gearbox on"
- 2 Key switch "Transfer shift gearbox on/off"

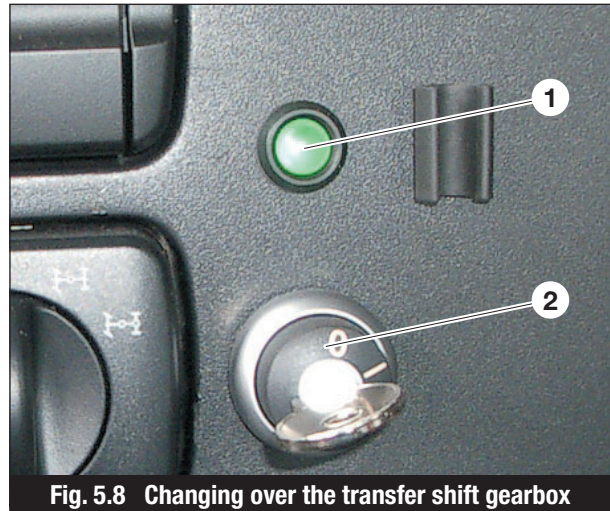

## 5.9 Surplus concrete discharge opening

- 1 Lever "Surplus concrete discharge opening"
- 2 Adjusting screws

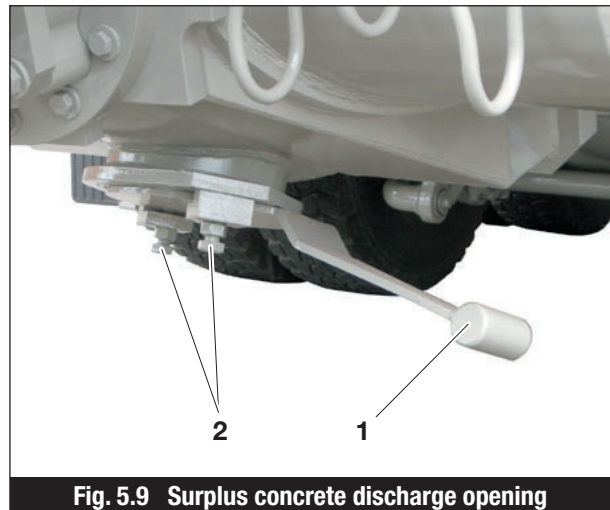

## 5.10 Water tank shut-off valve

- 1 Ball valve "Water tank filling / emptying"
- 2 Filling and emptying connection

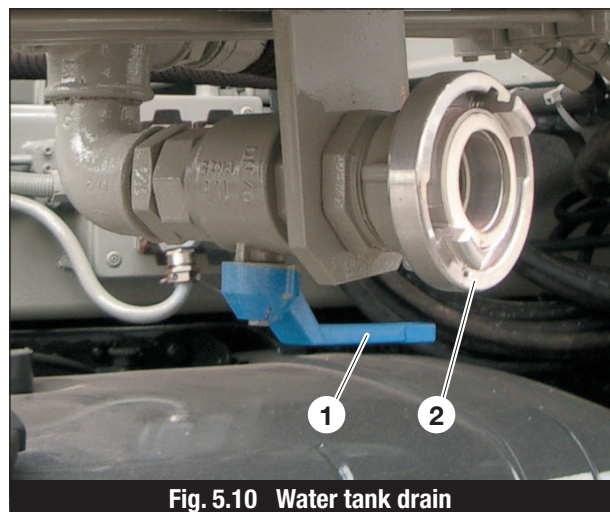



### 5.11 Water connection, rear

- 1 Geka connection for water hose
- 2 Ball valve for retaining or draining the water up to the water pump
- 3 Ball valve fro filling wash-out tank (optional)

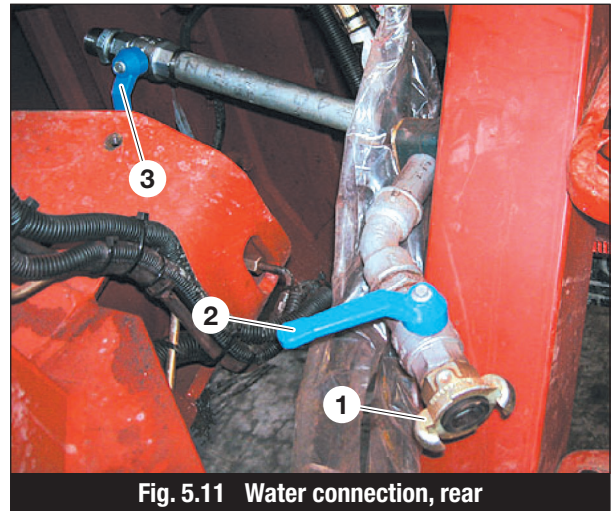

**Fig. 5.11** Water connection, rear

### 5.12 Radio remote control / cable remote control

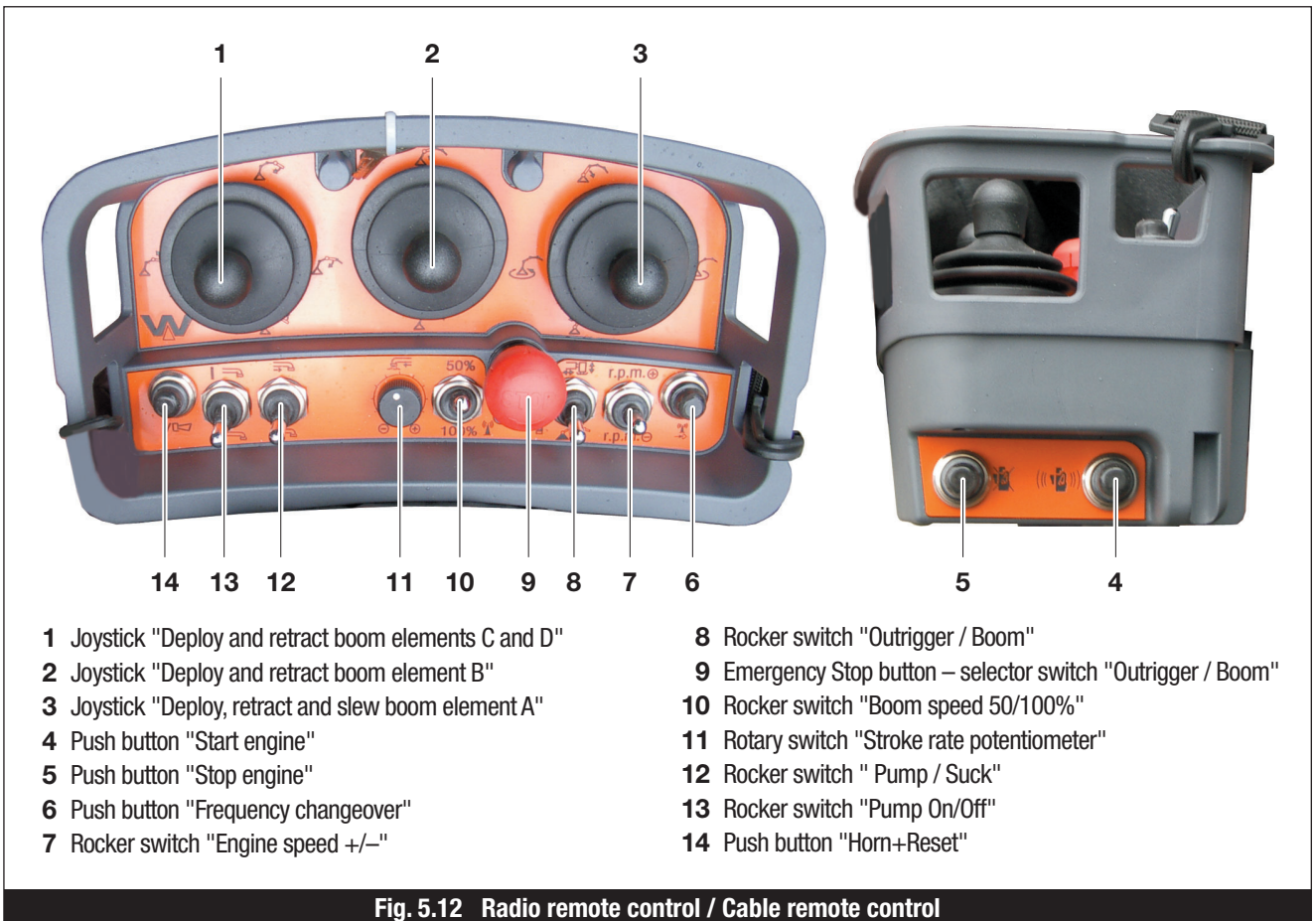

**Fig. 5.12** Radio remote control / Cable remote control



### 5.13 Emergency Stop button

**Emergency Stop buttons are fitted to the truck-mounted concrete pump at the following places:**

- ☞ Control panel desk
- ☞ Outrigger control block, right
- ☞ Boom control block
- ☞ Radio remote control
- ☞ Outrigger control block, left
- ☞ Cable remote control



**Fig. 5.13** Emergency Stop button

### 5.14 Control elements on the hydraulic block

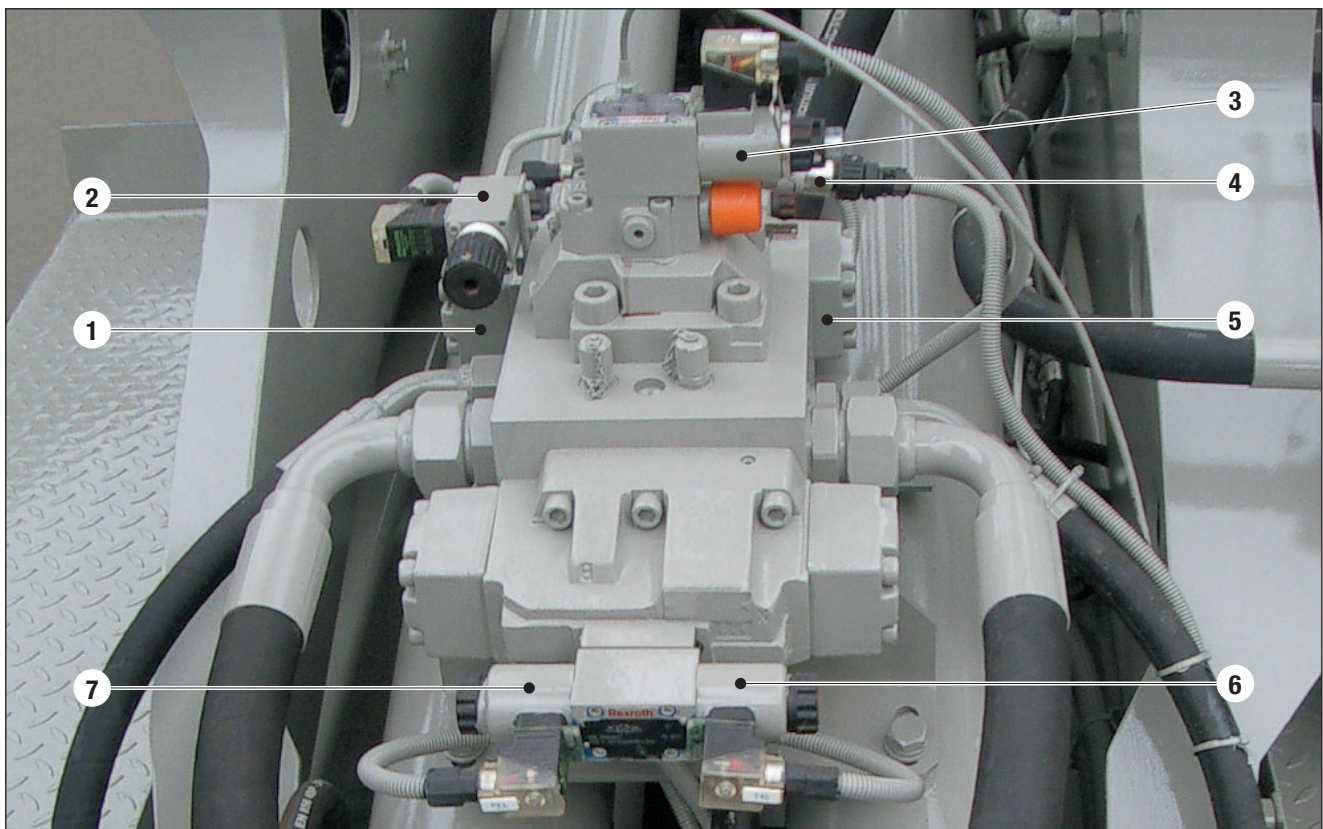

- |                   |             |
|-------------------|-------------|
| 1 Valve Y5b       | 5 Valve Y5a |
| 2 Push button     | 6 Valve Y4a |
| 3 Valve Y3        | 7 Valve Y4b |
| 4 Pressure sensor |             |

**Fig. 5.14** Hydraulic block



## 6. Driving, towing, loading

### 6.1 Driving



#### **DANGER:**

The centre of gravity of the truck-mounted concrete pump is very high, due to the nature of the design. Take extreme care when negotiating curves!

The truck-mounted concrete pump may be driven on public roads only in accordance with the applicable legislation and regulations of the country concerned. The driver must have a valid driving licence for this truck-mounted concrete pump.

#### 6.1.1 Before a journey

*The following actions must be taken before a journey:*

- take all actions as described in the vehicle manufacturer's user manual
- check all components and transport restraints on the truck-mounted concrete pump to ensure they are in good condition
- check the outrigger catches to ensure they are properly engaged
- check that all components are secured against free movement
- check that the boom is in the transport position (height)

#### 6.1.2 During the journey

Always drive the truck-mounted concrete pump having regard to the dimensions of the vehicle and its weight. Further information on driving can be found in the separate vehicle manufacturer's user manual.

## 6.2 Towing

The truck-mounted concrete pump should be towed only in accordance with the instructions of the vehicle manufacturer, and only using the attachment points provided for the purpose. For towing the truck-mounted concrete pump, the front towing ring should be used; for towing other vehicles by the truck-mounted concrete pump, the rear towing plate.

Further information on towing can be found in the separate vehicle manufacturer's user manual.



### 6.3 Loading



**CAUTION:**

**Not all the identified lifting points are suitable for lifting the complete machine. Always check before lifting!**

The attachment points for lifting the truck-mounted concrete pump are specifically identified. A transport company should be entrusted with loading and transporting by crane if necessary.



## 7. Starting up and operating

This chapter contains all the important information for the operator to safely start up and operate the truck-mounted concrete pump.



### WARNING:

Before first starting up the truck-mounted concrete pump, the operator must carefully read through this Chapter 7 “Starting up and operating” and perform all checks in accordance with the information set out in this chapter. Only when the operating safety has been assured in this way may the truck-mounted concrete pump be started up.



### NOTE:

During start-up and operation, comply with the safety instructions set out in Chapter 2!

### a. Personal safety equipment

In the entire working area of the truck-mounted concrete pump, suitable safety equipment should be worn, particularly when handling mortar additives.

The symbols for the necessary safety equipment are shown in the graphics panel alongside.

The symbols shown are as follows:

1. Hard hat
2. Safety boots
3. Ear defenders
4. Safety gloves
5. Safety glasses
6. Face mask
7. Protective clothing
8. Safety harness



Fig. 7.1 Symbols for personal safety equipment



### **b. General information for operating the truck-mounted concrete pump**

The operator must be familiar with and comply with the user manual and all safety measures for operating the truck-mounted concrete pump. He must be able to control the machine.

#### **b.1 Before starting up**

- ☞ Secure the working- and hazard area and barrier it off if necessary
- ☞ Top up the fluids (hydraulic oil, fuel, water)
- ☞ Check the functioning of all safety devices - and controls
- ☞ Lubricate all grease points and check that the lubrication system is functioning
- ☞ Check the stability of the machine
- ☞ Check the conveying pipes for alignment and degree of wear (wall thickness measurement)

#### **b.2 During operation**

- ☞ Never allow the machine to operate unattended
- ☞ Stop the machine immediately if any fault occurs that might create a safety hazard
- ☞ In the event of blockages the material must be return to the hopper immediately. Start up again slowly!
- ☞ Open the snap couplings on the conveying pipes only when the conveying system has been depressurised
- ☞ When opening pipe joints, wear safety glasses to protect the eyes from spurting concrete
- ☞ Never reach into or on to moving parts, first switch the engine off or depressurise the accumulator
- ☞ Do not modify any safety device

#### **b.3 At the end of operations**

- ☞ Empty the conveying pipes
- ☞ Clean the conveying pipes using a cleaning ball and water
- ☞ Clean the hopper and the complete machine
- ☞ Perform routine maintenance, and repair any faults that have developed whilst the machine was running





## 7.1 Setting up the truck-mounted concrete pump

Select the location having regard to the safety instructions in section 2.7, and drive the machine to the location.



**NOTE:**

**Be sure to allow sufficient space for setting up truck-mounted concrete pump! Allow additional space for the mixer truck also!**

**Fully deployed outriggers right:**

Space requirement at the front:  $8,5 \text{ m} + 0,6 \text{ m} = 9,1 \text{ m}$   
 Space requirement at the rear:  $8,0 \text{ m} + 0,6 \text{ m} = 8,6 \text{ m}$   
 Slewing range:  $0^\circ - 360^\circ$

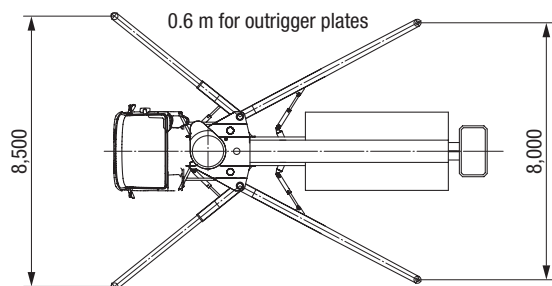

**Narrow outriggers one side:**

Space requirement at the front:  $6,1 \text{ m} + 0,6 \text{ m} = 6,7 \text{ m}$   
 Space requirement at the rear:  $5,7 \text{ m} + 0,6 \text{ m} = 6,3 \text{ m}$   
 Slewing range:  $0^\circ - 200^\circ$  oder  $360^\circ - 160^\circ$

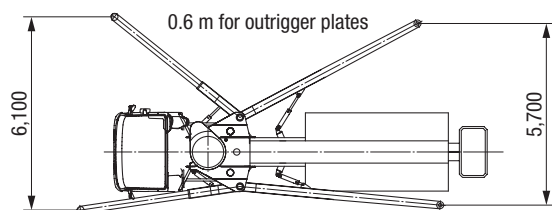

**CAUTION: Narrow outriggers may only be used when XXA controls are installed and in use!**

**Narrow outriggers on both sides:**

Space requirement at the front:  $3,7 \text{ m} + 0,6 \text{ m} = 4,3 \text{ m}$   
 Space requirement at the rear:  $3,4 \text{ m} + 0,6 \text{ m} = 4,0 \text{ m}$   
 Slewing range:  $160^\circ - 200^\circ$

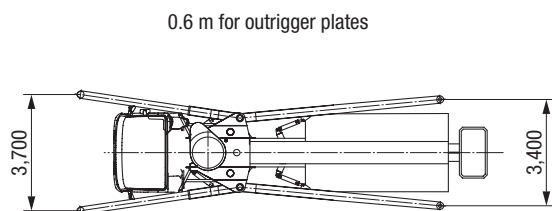

**CAUTION: Narrow outriggers may only be used when XXA controls are installed and in use!**

**Fig. 7.2 Space requirement for outriggers for the truck-mounted concrete pump**

On sloping ground put chocks behind the wheels, release the brakes and allow the truck-mounted concrete pump to roll back on to the chocks. Then apply the handbrake and extend the outriggers.

The ground must be checked for its load-bearing capability.



## 7.2 Adjustments and actions before starting up

### 7.2.1 Changing over the transfer shift gearbox

Use the key switch (2) in the cab to change over the transfer shift gearbox in the drive train from travel drive "O" to pump drive "I".

For the changeover the ignition switch must be in the "ON" position (vehicle engine can run, but need not be running), the pneumatic pressure must be more than 5 bar and the clutch fully disengaged.

The indicator lamp (1) lights up when the gearbox is switched to pump drive.

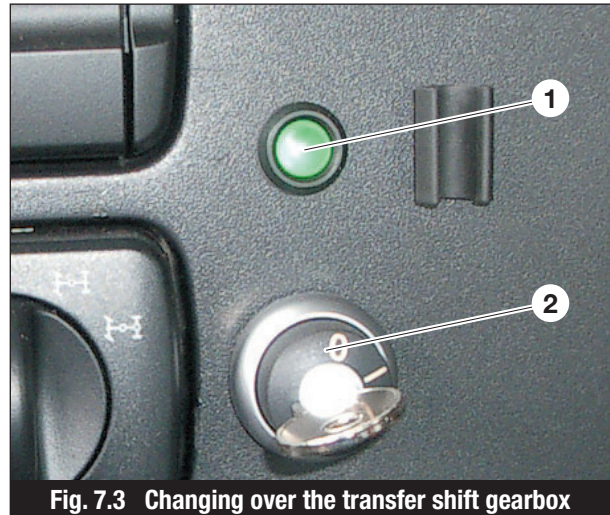

Fig. 7.3 Changing over the transfer shift gearbox

To drive the hydraulics a definite gear must be selected as shown in the information plate.

Example: 8 high



Fig. 7.4 Selecting a gear



### WARNING:

- ☞ Selecting the wrong gear can lead to overspeeding and damage to the hydraulic pumps!
- ☞ Engine braking must be disengaged!
- ☞ The handbrake must be applied!



The “Controls ON” indicator lamp (3) remains on as long as the ignition is on and the gearbox is set for pump drive. This function is independent of any Emergency Stop indication.

The vehicle engine must be running.

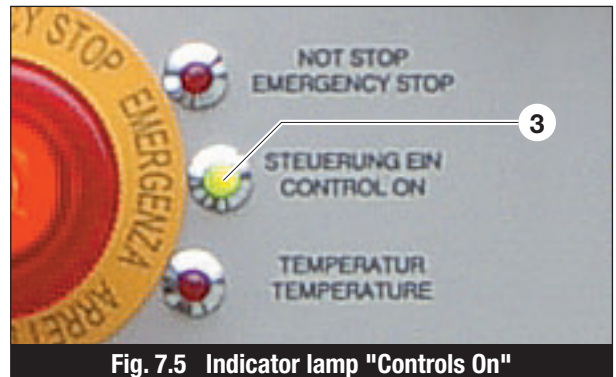

Fig. 7.5 Indicator lamp "Controls On"

### 7.2.2 Emergency Stop

The machine is fitted with 4 illuminated Emergency Stop buttons, plus an Emergency Stop button on each remote control pendant.

Each Emergency Stop button immediately switches off all functions and movements (optionally the engine can be switched off by an Emergency Stop).

*The Emergency Stop buttons are located as follows:*

- Control panel desk (Item 1, Fig. 5.2)
- Boom control block (Item 3, Fig. 5.4)
- Left hand outrigger controls (Item 2, Fig. 5.5)
- Right hand outrigger controls (Item 2, Fig. 5.6)
- Radio remote control (Item 9, Fig. 5.12)
- Cable remote control (Item 9, Fig. 5.12)

The activated Emergency Stop button is indicated in the control panel by the flashing Emergency Stop indicator lamp (Item 12, Fig. 5.2) and at the activated Emergency Stop button itself (except for remote control).

After the reason the activating the Emergency Stop button has been rectified, the activated Emergency Stop button can be released by pulling or twisting.



#### NOTE:

**The controls must be reset after an Emergency Stop by pressing the “Horn/Reset” rocker switch (Item 6, Fig. 5.2) on the control panel desk.**

All functions that were in operation when the Emergency Stop button was pressed must be restarted.



When the Emergency Stop button is pressed, the following conditions are set on the truck-mounted concrete pump:

- **Truck**  
Engine is switched to idling (or optionally switched off)
- **Truck-mounted concrete pump**  
Pumping / sucking is immediately switched off
- **Distributor boom**  
The distributor boom is halted at its current position

### 7.2.3 Selecting the operating mode

The control panel is at the right rear of the vehicle.

The functions on the control panel desk “Pump/Suck (11)” and “Stroke rate (13)” are disabled if the remote control is activated.

The key switch (14) allows switching between “Control Desk” and “Remote control”.

If the cable for remote control is plugged in, remote control is activated automatically.

In the setting “Remote control” the respective remote control pendant must be switched on, otherwise the controls are switched off in an Emergency Stop.

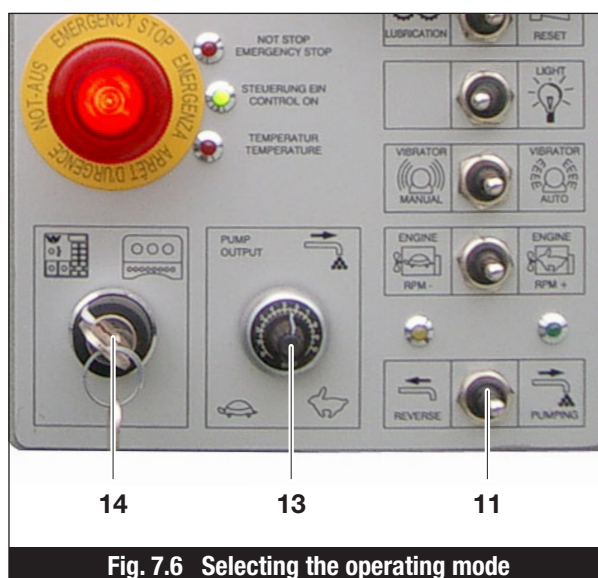

Fig. 7.6 Selecting the operating mode



#### NOTE:

The key should be withdrawn when the machine is in operation, so that no unauthorised person can tamper with the outriggers.

### 7.3 Operating the outriggers



#### DANGER:

When the outriggers are being slewed in/out or extended there is high crush risk hazard.





- ☞ The operator must continuously monitor the hazard area.
- ☞ The outrigger slew in/out and extension areas must be kept clear of all persons and objects.
- ☞ All instructions set out in Chapter 2 “Safety instructions” must be strictly complied with.

### 7.3.1 Stability checking

If the option “Stability checking” is installed, refer to the separate user manual.

### 7.3.2 Extending / retracting the outriggers



#### **DANGER:**

- ☞ For safety reasons the operator must always face towards the outrigger that is being extended / retracted and have an unimpeded view of the entire hazard area!
- ☞ When activating the functions with the respective operating lever, for safety reasons the other hand should always be keeping the safety button (Item 3, Fig. 5.5 / Item 1, Fig. 5.6) pressed!

- Moving the operating lever on the outrigger control block **downwards**, means for all functions “**Extend**”.
- Moving the operating lever on the outrigger control block **upwards**, means for all functions “**Retract**”.
- The functions “Slew out” and “Telescopic extension” can be performed concurrently for the front outriggers. This causes the front outriggers to extend automatically to their full extent.
- The outriggers are secured in the stowed position for vehicle travel by hydraulically locked catches.



#### **WARNING:**

**Before moving the vehicle and before starting work make absolutely sure that the hydraulically locked catches are engaged!**



### NOTE:

If the operating mode selector switch (Item 14, Fig. 5.2) is in the remote control position, the remote control must be switched from the Boom control mode to the Outrigger control mode, using rocker switch (Item 8, Fig. 5.12).

### 7.3.2.1 Back-up operation

If the control system fails, the outriggers can be operated manually from the master control block. To do this a send person must stand at the “Outrigger/Boom” control panel and hold the control lever (Item 4, Fig. 7.11) in the UP position.

### 7.3.3 Functions at outrigger control block, left

Move the operating lever as shown to perform the respective functions on the outrigger.

- 1 Circular level
- 2 Emergency Stop button
- 3 Outrigger safety button
- 4 Extending / retracting the rear outrigger cylinder
- 5 Slewing the rear outrigger cylinder out / in
- 6 Slewing the front outrigger cylinder out / in
- 7 Extending / retracting the front telescopic outrigger
- 8 Extending / retracting the front outrigger cylinder

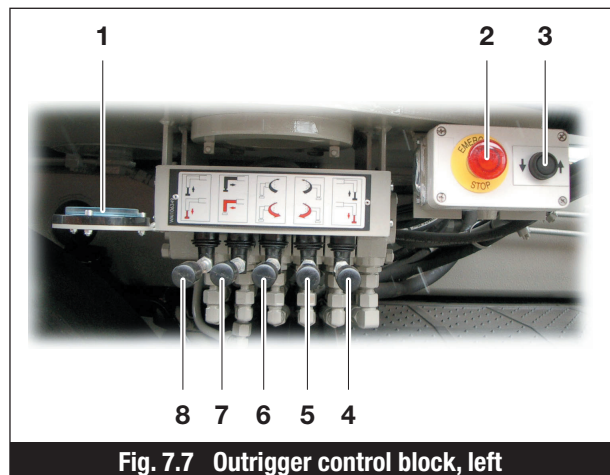

Fig. 7.7 Outrigger control block, left

### 7.3.4 Functions at outrigger control block, right

Move the operating lever as shown to perform the respective functions on the outrigger.

- 1 Outrigger safety button
- 2 Emergency Stop button
- 3 Circular level
- 4 Extending / retracting the front outrigger cylinder
- 5 Extending / retracting the front telescopic outrigger
- 6 Slewing the front outrigger cylinder out / in
- 7 Slewing the rear outrigger cylinder out / in
- 8 Extending / retracting the rear outrigger cylinder

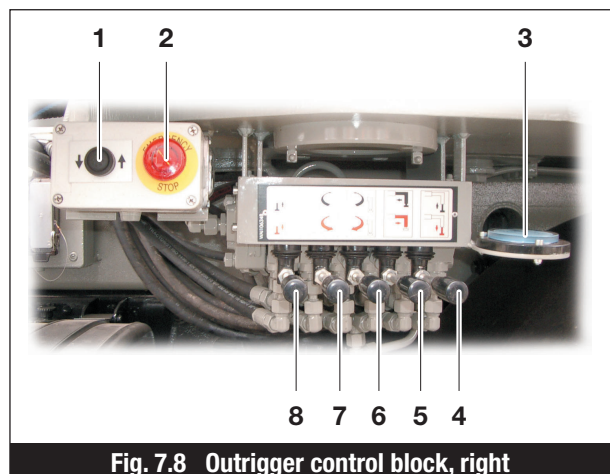

Fig. 7.8 Outrigger control block, right



### 7.3.5 Building up the outrigger

- Fully extend the outrigger and fully extend the telescopic sections.
- Extend the front telescopic outriggers until it clicks into a second registration point at the working setting (see detail, left).
- Check that the arrows match (see detail, right), indicating that the outrigger is fully extended.
- Extend the front outrigger cylinder so far that the front wheels are lifted clear of the ground.
- The rear wheels must remain gently touching the ground (braking and stability).

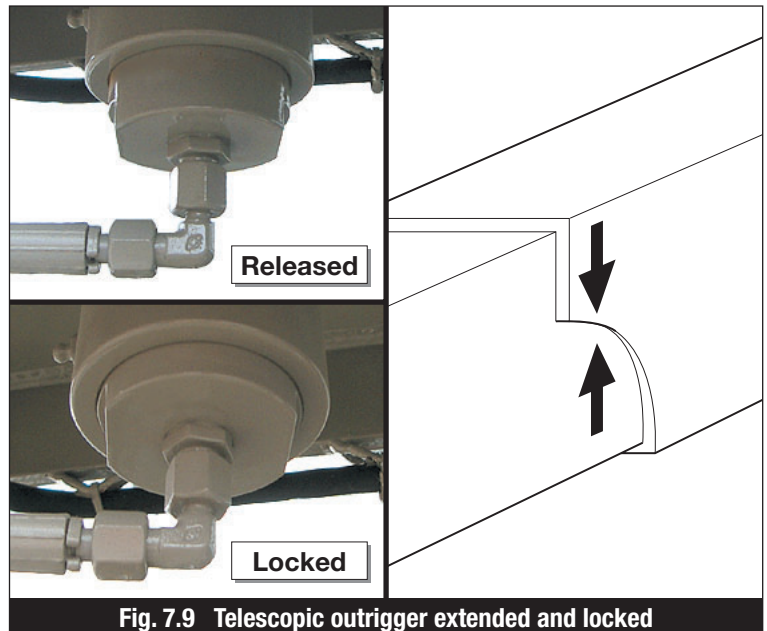

Fig. 7.9 Telescopic outrigger extended and locked

- The truck-mounted concrete pump may not stand more than 3° from level. Check the circular levels

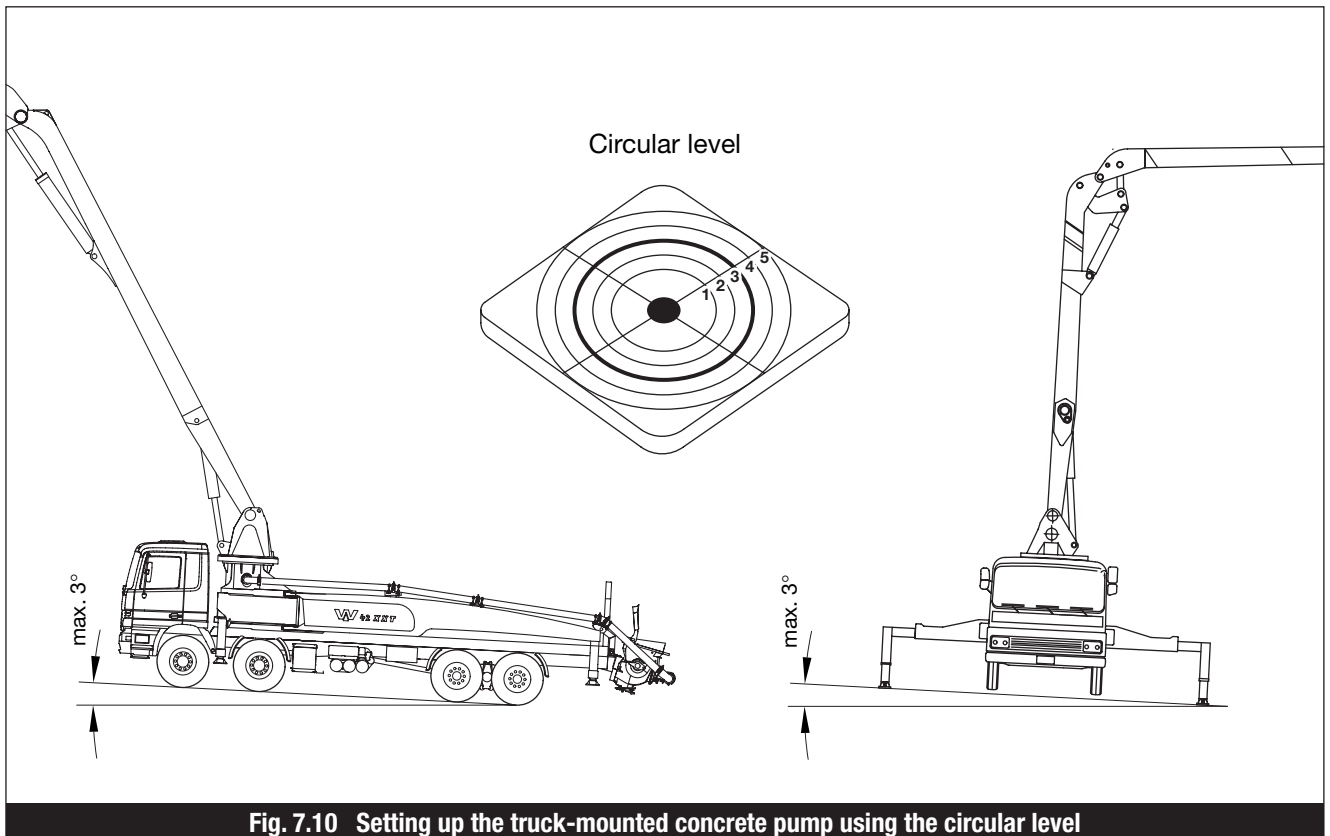

Fig. 7.10 Setting up the truck-mounted concrete pump using the circular level



### 7.4 Distributor boom operation



#### WARNING:

- Do not deploy the distributor boom until the truck-mounted concrete pump outriggers are fully extended!
- Never drive the truck when the distributor boom is deployed!
- When deploying and stowing the distributor boom there are many points against which the boom can foul and cause damage. Therefore be sure to follow the correct sequence of operations for deploying the boom!



#### NOTE:

Normally the distributor boom is controlled using the radio/cable remote control pendant. All boom functions are performed proportionally.

#### 7.4.1 Distributor boom operation using the master control block



#### NOTE:

Distributor boom operation using the master control block should only be used as back-up. Whenever possible control the boom using the radio/cable remote control pendant.

- Set the operating mode selection switch (Item 14, Fig. 7.6) to "Control panel desk".
- Control each boom element individually by moving the respective control levers Element A (8), Element B (7), Element C (6) and Element D (5) in desired direction.

Moving a control lever downwards moves the element inwards, moving a control lever upwards moves the element outwards.

- The boom rotation lever (9) controls the rotation of the boom.  
Pressing the control lever downwards rotates the boom clockwise, pressing the control lever upwards rotates the boom anticlockwise.

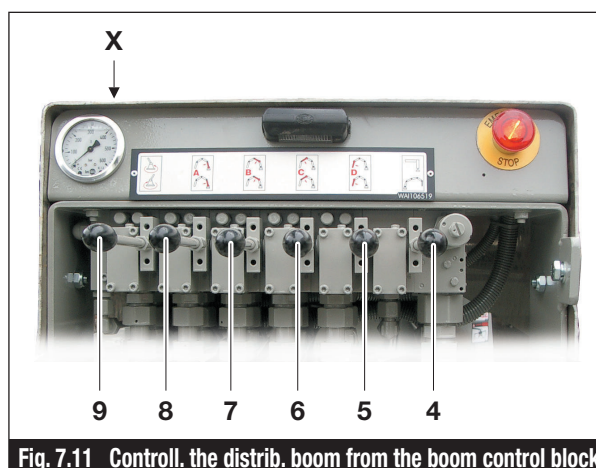
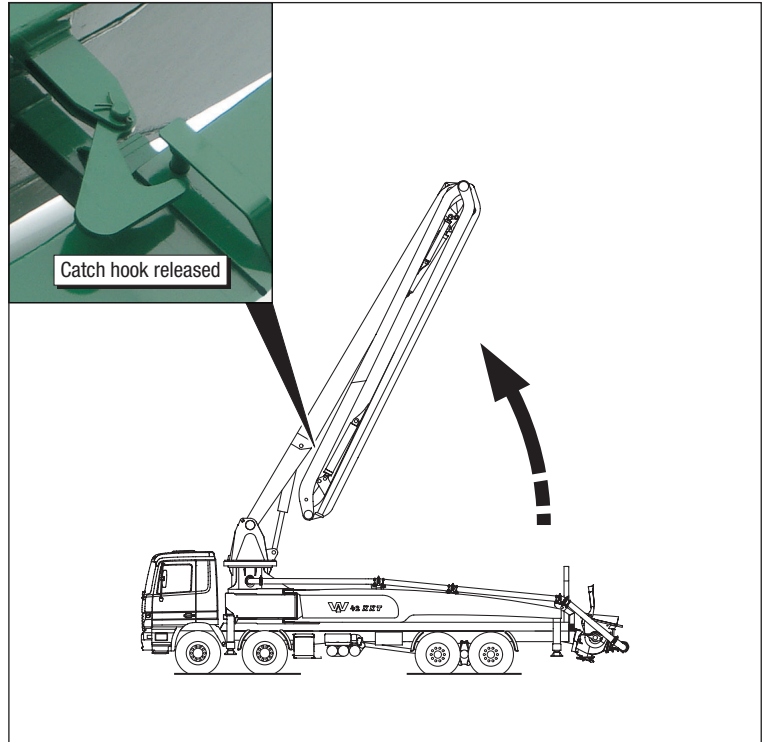

Fig. 7.11 Control. the distrib. boom from the boom control block





- Press control lever boom A (Item 8, Fig. 7.11) and deploy the boom package until the catch hook releases.



**Fig. 7.12** Deploy the boom package, the catch hook releases

- Press the boom rotation control lever (Item 9, Fig. 7.11) to rotate the boom package into the working position.

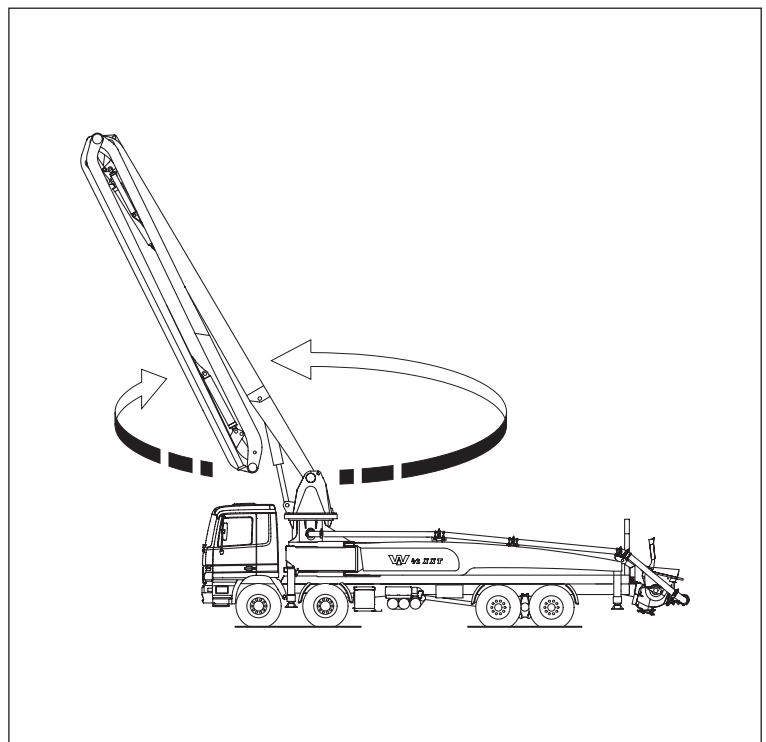

**Fig. 7.13** Slew the boom package into the working position



- Press control lever B (Item 7, Fig. 7.11) and deploy boom element B at 120° to boom element A.

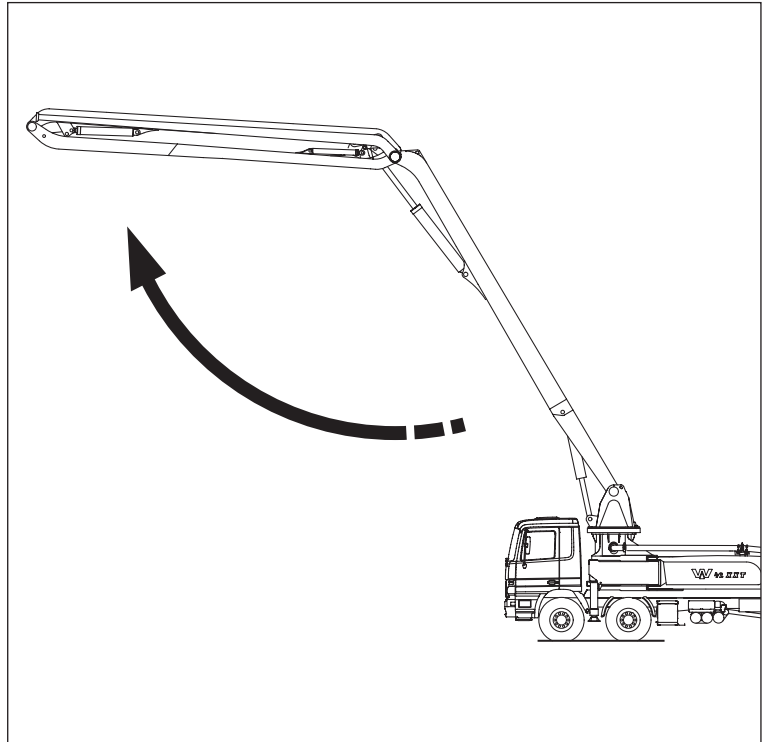

Fig. 7.14 Deploy boom element B

- Press control lever C (Item 6, Fig. 7.11) and deploy boom element C at 90° to boom element B.

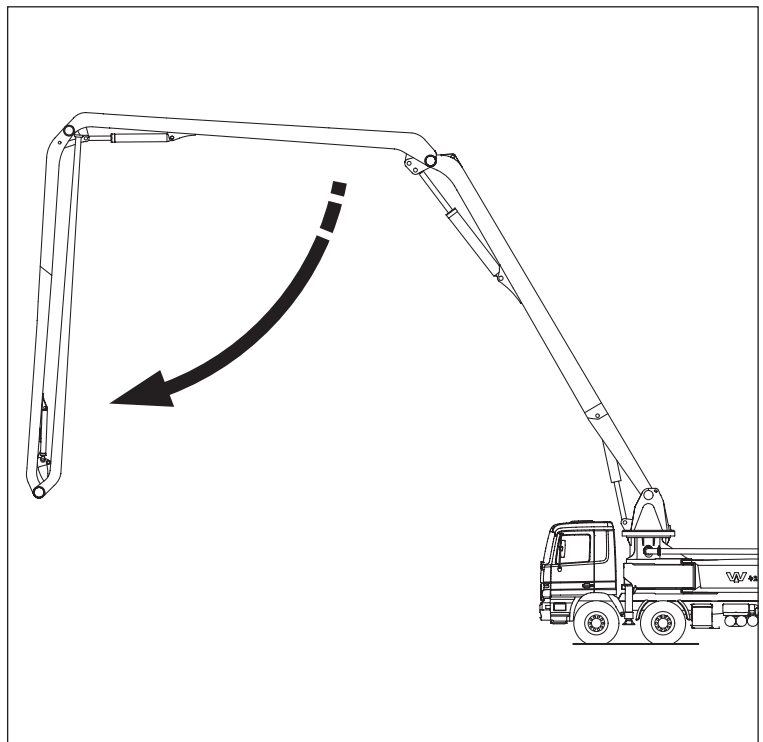
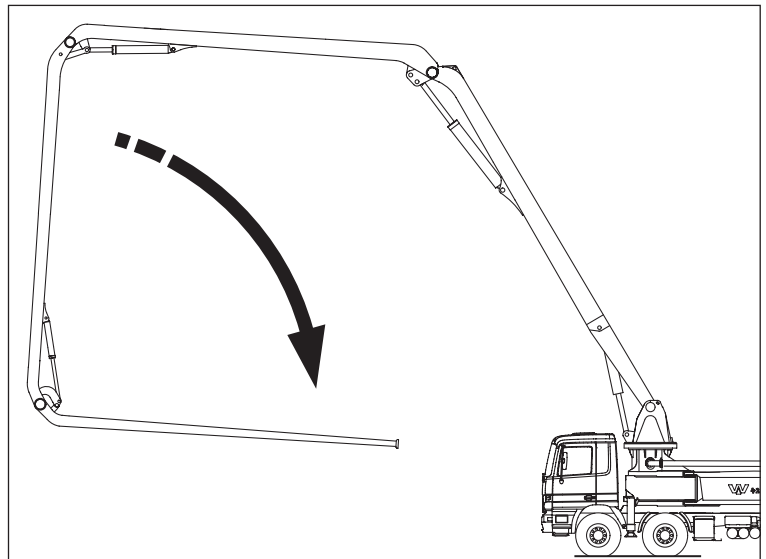

Fig. 7.15 Deploy boom element C



- Press control lever D (Item 5, Fig. 7.11) and deploy boom element D at 90° to boom element B.
- Position boom element D horizontally approx. 1 m above the ground.



**Fig. 7.16 Deploy boom element D**

- Open the discharge hose retainer (arrowed) and release the discharge hose.
- Use the control levers (Items 5 to 9, Fig. 7.11) on the boom control block to move the distributor boom into the desired working position.



**Fig. 7.17 Release the discharge hose**



### **WARNING:**

**When using manual control at the boom control block all safety circuits including Emergency Stop are disabled.**

#### **7.4.1.1 Back-up slewing function**

If the controls system fails, slewing the boom must be enabled by engaging the additional back-up controls (Item X, Fig. 7.11) by inserting a suitable screwdriver (4 mm) into the holes in the cover and pushing.



### 7.4.2 Controlling the distributor boom using the radio remote control pendant

- Set the operating mode selection switch (Item 14, Fig. 7.6) to “Remote control”.
- Activate the remote control pendant. See information in the separate user manual supplied by the manufacturer.
- Release the Emergency Stop by pressing the Horn/Reset (**14**). The horn will sound.
- Switch the selector switch “Outrigger/Boom” (**8**) to “Boom” and uncap the Emergency Stop button.
- The 50%/100% switch (**10**) controls the boom speed, 50% when pumping, 100% when deploying / stowing.
- Press the master switch “Deploy boom element A / Slew boom” (**3**) and deploy boom element A until the catch hook releases and the boom element B can be deployed (see Fig. 7.12).
- Press the master switch “Deploy boom element B” (**2**) and deploy boom element B until it is approx. 120° to boom element A (see Fig. 7.14).
- Use the joystick “Deploy boom element C and D” (**1**) to deploy boom element C to 90° to boom element B (see Fig. 7.15).
- Use the joystick “Deploy boom element C and D” (**1**) to deploy boom element D to 90° to boom element C (see Fig. 7.15).
- Position boom element D horizontally approx. 1 m above the ground.
- Open the catch and release the discharge hose (see Fig. 7.17).
- Use the joystick s(**1 to 3**) on the radio remote control to move the distributor boom to the desired working position.

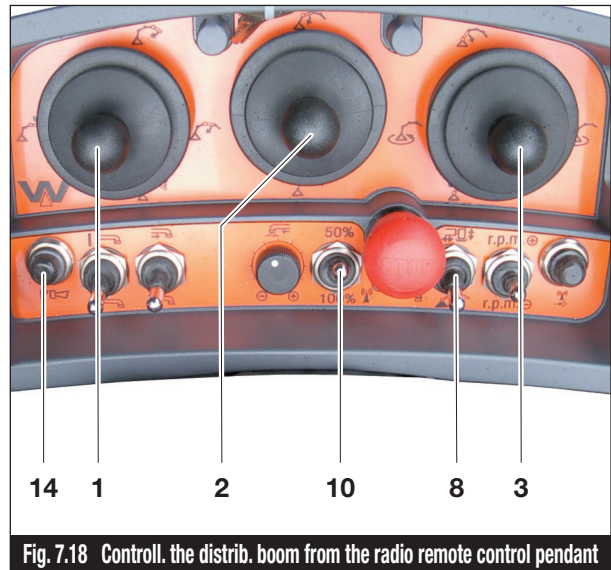
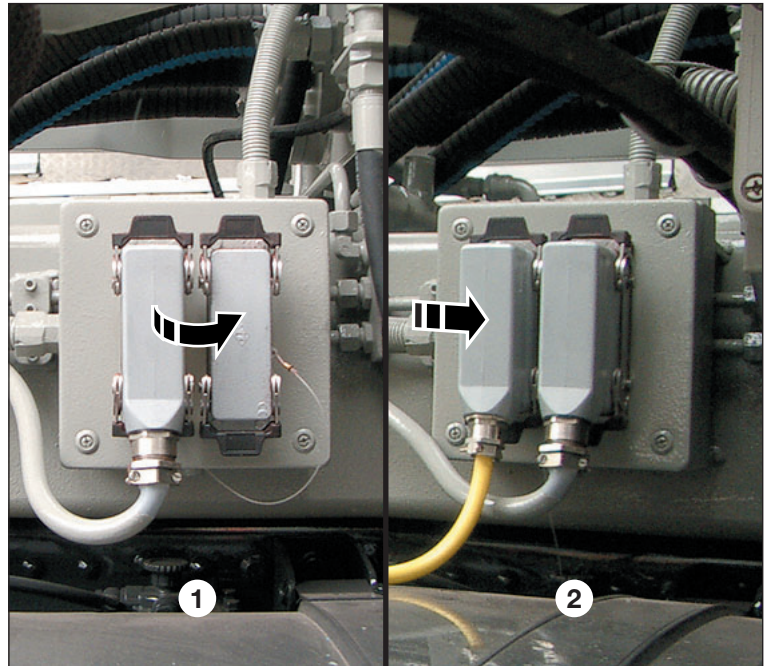

Fig. 7.18 Control. the distrib. boom from the radio remote control pendant



### 7.4.3 Controlling the distributor boom using the cable remote control pendant

- Remove the right hand protective cap.
- Unplug the “Radio” plug from the left hand socket and plug it into the free right hand socket **1**. Lock the plug in place.
- Plug the extension cable for the cable remote control into the left hand socket **2**. Lock the plug in place. Radio remote control is now deactivated.
- Set the operating mode selection switch (Item 14, Fig. 7.6) to “Remote control”.
- Release the Emergency Stop by pressing the Horn/Reset (Item 14, Fig. 7.18). The horn will sound.
- Switch the selector switch “Outrigger/ Boom” (Item 8, Fig. 7.18) to “Boom” and uncap the Emergency Stop button.
- The 50%/100% switch (Item 10, Fig. 7.18) controls the boom speed, 50% when pumping, 100% when deploying / stowing.
- Press the master switch “Deploy boom element A / Slew boom” (Item 3, Fig. 7.18) and deploy boom element A until the catch hook releases and the boom element B can be deployed (see Fig. 7.12).
- Press the master switch “Deploy boom element A / Slew boom” (Item 3, Fig. 7.18) to move the distributor boom into the position where the discharge hose retainer can be opened.
- Press the master switch “Deploy boom element B” (Item 2, Fig. 7.18) and deploy boom element B until it is approx. 120° to boom element A (see Fig. 7.14).
- Use the joystick “Deploy boom element C and D” (Item 1, Fig. 7.18) to deploy boom element C to 90° to boom element B (see Fig. 7.15).
- Use the joystick “Deploy boom element C and D” (Item 1, Fig. 7.18) to deploy boom element D to 90° to boom element C (see Fig. 7.16).
- Position boom element D horizontally approx. 1 m above the ground.
- Open the catch and release the discharge hose (see Fig. 7.17).
- Use the joystick s**(1 to 3)** on the radio remote control to move the distributor boom to the desired working position.



**Fig. 7.19 Plug the extension cable for the cable remote control**



## 7.5 Pump operation

### 7.5.1 Motor Start/Stop, Speed control

The vehicle engine can be started from the remote control pendant using the push button (Item 4, Fig. 7.20). This can only be done if the key switch (Item 14, Fig. 7.6) on the control panel desk is set to "Remote Control".

Pressing the push button (Item 5, Fig. 7.20) stops the vehicle engine, and inhibits its restart for approx. 10 sec.

Pressing the rocker switch (Item 7, Fig. 7.20 or Item 9, Fig. 7.21) brings the vehicle engine from idling to full speed within 10 sec.

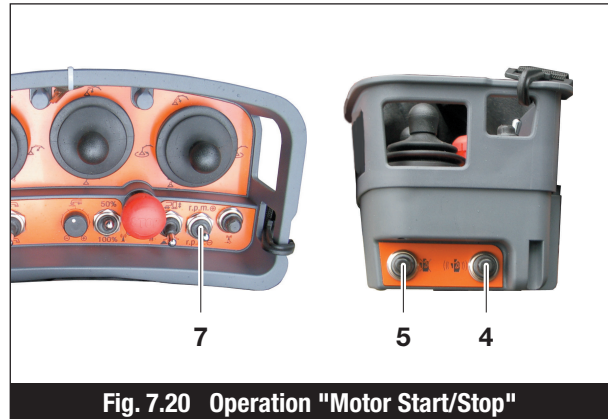

Fig. 7.20 Operation "Motor Start/Stop"

### 7.5.2 "Pump/Suck" control at the control panel desk

The operating mode selection switch (Item 14, Fig. 7.21) must be set to "Desk". The rocker switch (Item 11, Fig. 7.21) selects "Pump" or "Suck". For confirmation one of the two indicator lamps (Item 10 or 12, Fig. 7.21) will light.

The stroke rate depends on the setting of the stroke rate potentiometer (Item 13, Fig. 7.21) and the engine speed.

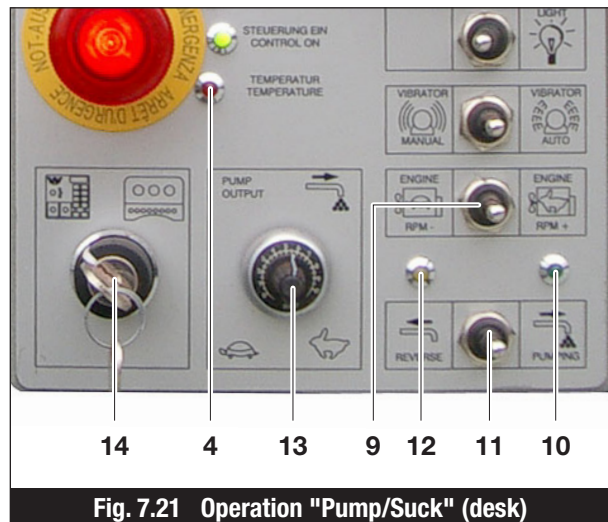

Fig. 7.21 Operation "Pump/Suck" (desk)



#### NOTE:

Opening the safety grill or pressing an Emergency Stop button (whilst the "Pump/Suck" switch is activated), will deactivate the "Pump/Suck" function.



#### NOTE:

If the hydraulic oil temperature exceeds 80 °C, the pump function is stopped and the indicator lamp (Item 4, Fig. 7.21) on the control panel desk will light. Sucking the concrete back remains available. The hydraulic system must be cooled down as quickly as possible by appropriate means (see section 7.6.4).



### 7.5.3 “Pump/Suck” control by radio remote control / cable remote control

The operating mode selection switch (Item 14, Fig. 7.6) must be set to “Radio remote control”.

The rocker switch (Item 12, Fig. 7.21) on the remote control pendant is pre-set to “Pump” or “Suck”. Select “Pump” or “Suck” using the rocker switch (Item 13, Fig. 7.21).

The stroke rate depends on the setting of the stroke rate potentiometer (Item 11, Fig. 7.22) and the engine speed.

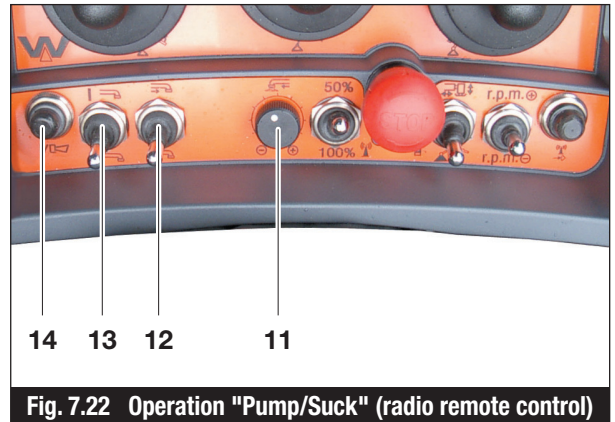

Fig. 7.22 Operation “Pump/Suck” (radio remote control)



#### NOTE:

Opening the safety grill or pressing an Emergency Stop button (whilst the “Pump/Suck” switch is activated), will deactivate the “Pump/Suck” function, which must then be restarted by switching the rocker switch (Item 13, Fig. 7.22) off and on again.

### 7.5.4 Back-up function for “Pump/Suck”



#### NOTE:

This function should only be switched on if the normal “Pump/Suck” controls are not operational!

#### 7.5.4.1 Pumping with the control panel desk or via radio remote control/cable remote control

- Set the Back-up Pump control selector switch (Item 2, Fig. 5.7) to position “A or B”  
If the pump does not start (see trouble-shooting), back-up operation may be necessary in two possible fault situations:



### Fault possibility 1: Defective sensors in the drive cylinder or oscillation cylinder

- Set the Back-up Pump control selector switch (Item 2, Fig. 5.7) to position “B”
- Set the pressure switch (Item 2, Fig. 7.23) to the anticipated pumping pressure (min. 60 bar, max. 280 bar)
- Set the key switch (Item 14, Fig. 7.21) to position “Desk” or “Remote Control”
- Switch on the “Pump/Suck” function using rocker switch (Item 11, Fig. 7.6) or rocker switch (Item 13, Fig. 7.22)



#### NOTE:

- ☞ If the pressure at the pressure switch is set too low, the stroke will be short and the S-valve may not swing over fully.
- ☞ If the pressure at the pressure switch is set too high, the pump can stop at the end of its travel.

### Fault possibility 2: Controller failure

- Set the Back-up Pump control selector switch (Item 2, Fig. 5.7) to position “B”
- Set the key switch (Item 14, Fig. 7.21) to position “Desk” or “Remote control”
- Switch on the “Pump/Suck” function using rocker switch (Item 11, Fig. 7.21) or rocker switch (Item 13, Fig. 7.22)



#### NOTE:

- ☞ The stroke rate, the power control and switching speed do not function in setting “A”.
- ☞ The concrete delivery can only be changed via engine speed.
- ☞ A lower gear should generally be engaged on the vehicle gearbox.





### 7.5.4.2 Pump control at the hydraulic control block

When controlling the valves manually, never run the engine at full speed.



#### **WARNING:**

**Valves and solenoids can be up to 100 °C temperature, risk of burns!**

- Moving the drive cylinder  
Actuate Y4 a or b using a screwdriver (4 mm) or similar tool. Then press Y3 manually and move the drive cylinder to the desired position. Simultaneously releasing Y3 and Y4 will bring the cylinder to a halt.
- Moving the oscillation cylinder  
Actuate Y5 a or b using a screwdriver (4 mm) or similar tool. Then press Y3 manually and move the drive cylinder to the desired position. Simultaneously releasing Y3 and Y4 will bring the cylinder to a halt.

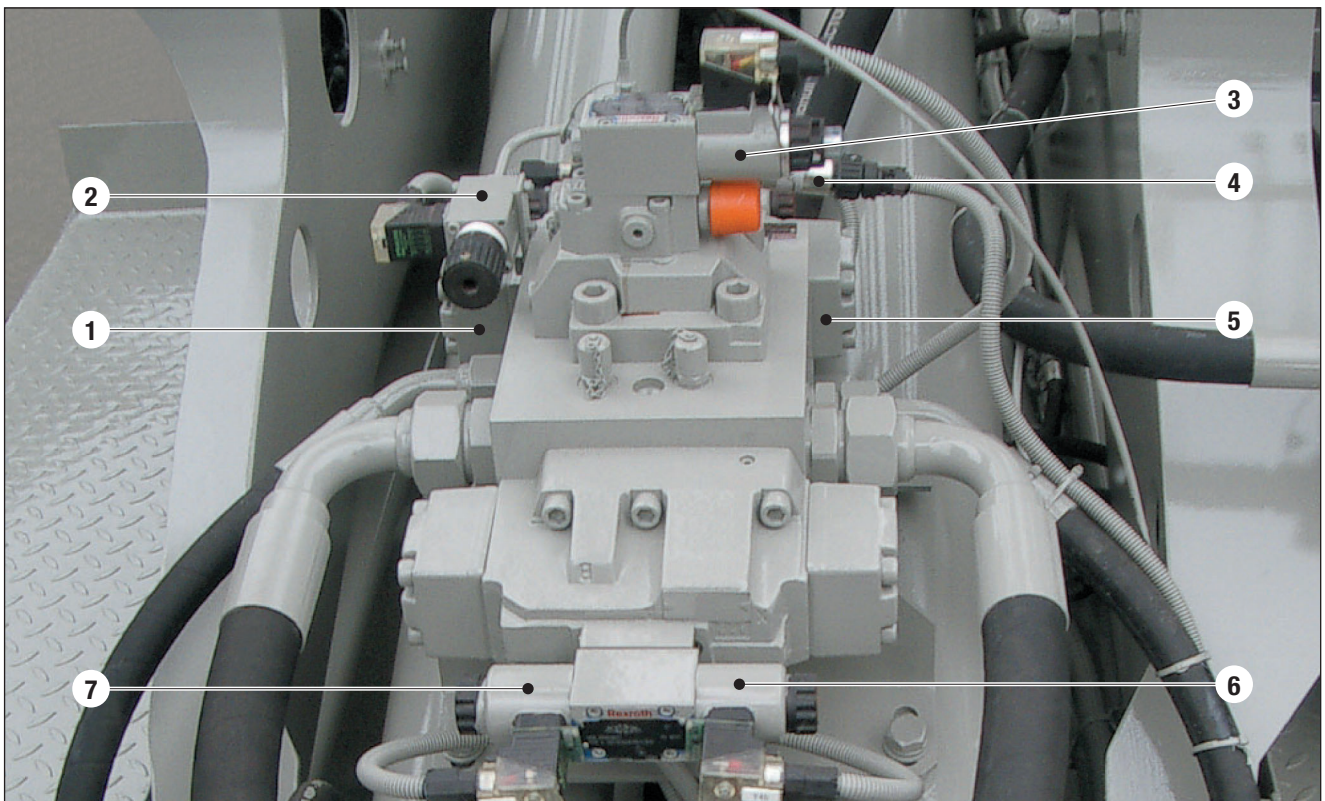

1 Valve Y5b	3 Valve Y3	5 Valve Y5a	7 Valve Y4b
2 Push button	4 Pressure sensor	6 Valve Y4a	

**Fig. 7.23 Pump hydraulic control block**



### 7.5.5 Agitator



#### **DANGER:**

- ☞ During cleaning work the control lever (Item 5, Fig. 7.24) must always be in the 0 position and must on no account be moved during the cleaning work!
- ☞ When working in the hopper, keep the vehicle engine switched off at all times!

The control lever “Agitator” (Item 5, Fig. 7.24) switches the agitator on (even when the Emergency Stop button has been pressed).

The agitator should always be set to move the concrete inwards to the centre – push the control lever to the right. Setting the agitator to move the concrete outwards (control lever to the left) should be done only for brief periods to relieve a blockage or to remix the concrete.

Opening the safety grill automatically stops the agitator.

The manometer (Item 1, Fig. 7.24) shows the actual pressure at the agitator / water pump (optionally: high pressure water pump and compressor). The maximum pressure that can be set is 210 bar.

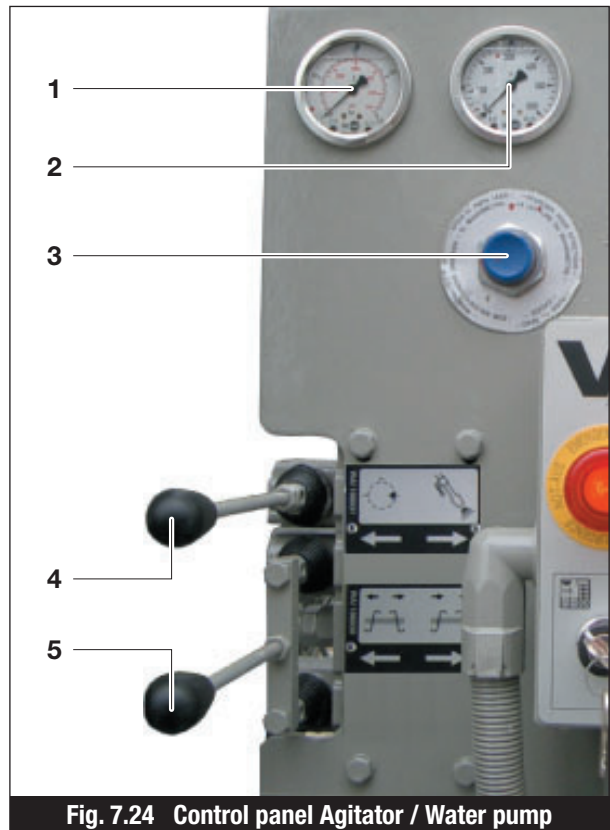

Fig. 7.24 Control panel Agitator / Water pump



### 7.5.6 Water pump

The control lever “Water pump” (Item 4, Fig. 7.24) switches the water pump on.

The manometer Item 1, Fig. 7.24) shows the actual pressure at the agitator / water pump (optionally: high pressure water pump and compressor). The maximum pressure that can be set is 210 bar.



#### NOTE:

**When the agitator is switched on, the power of the water pump is reduced.**

#### Option:

High pressure water pump or compressor, available as an option, are controlled by the same control lever (Item 4, Fig. 7.24).

### 7.5.7 Vibrator

The control lever “Vibrator” (Item 8, Fig. 7.24) switches the vibrator on.

Two operating modes are available:

MANUAL = Continuous operation

AUTO = The vibrator runs only when the pump is switched on.

### 7.5.8 Horn/Reset

Irrespective of the operating mode setting “Desk” or “Remote control” the horn can be sounded from any control panel using the rocker switch “Horn/Reset/Lubrication” (Item 6, Fig. 7.25).



Fig. 7.25 Control panel desk

If the Emergency Stop button has been pressed, provided all Emergency Stop buttons has been released, the controls will be switched on again (reset).



### NOTE:

If the operating mode selector switch (Item 14, Fig. 7.25) is set to “Remote control”, the Emergency Stop button on the Remotecontrol pendant (radio or cable) must be released.

### 7.5.9 Light

The light switch (Item 7, Fig. 7.25) switches all operating lights on, including the outrigger feet lighting (optional) and working area floodlights.

The lighting around the outrigger feet is permanently switched on. It needs only be plugged into the appropriate socket on the outrigger foot.

### 7.5.10 Concrete pump manometer

By-passing or blocking the manometer protection valve (Item 3, Fig. 7.24) the actual pump pressure is shown at the manometer (Item 2, Fig. 7.24). At 320 bar the hydraulic pump has switched to “0”. The probable cause is a blockage in the conveying pipe.

#### 7.5.10.1 Distributor boom manometer

The manometer (Item 1, Fig. 7.26) shows the actual pressure at the distributor boom.

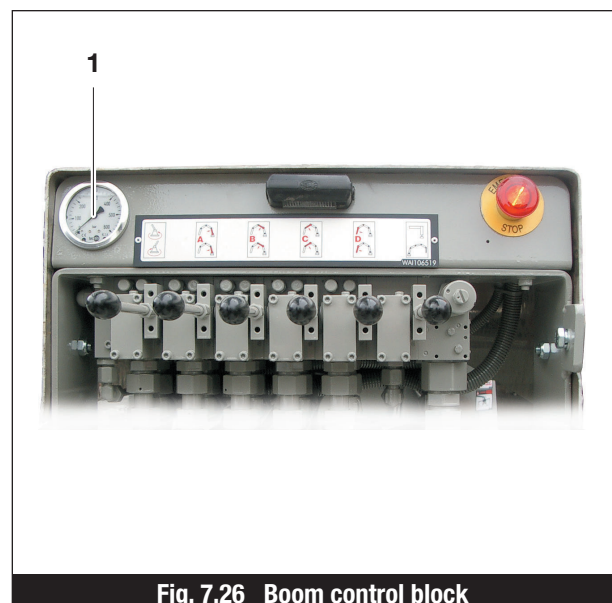



### 7.5.10.2 Filter clogging display

The display instrument (Item 1, Fig. 7.27) shows the degree of clogging of the return flow filter. If when the hydraulic oil is at operating temperature the needle is in the red zone, the filter element must be changed immediately.

The display instrument (Item 2, Fig. 7.27) shows the degree of clogging of the in-line filter. If the needle indicates 3 bar, the filter cartridge must be changed.



Fig. 7.27 Filter clogging indicator

### 7.5.10.3 Manometer for transfer shift gearbox



#### CAUTION:

- ☞ If the pressure is set too low, the transfer shift gearbox cannot change gear.
- ☞ If the pressure is set too low, the gearbox will be damaged.

Maximum pressure 5 bar, see manometer (Item 1, Fig. 7.28).

Pull and twist the rotary controller (Item 2, Fig. 7.28) to adjust the pressure.

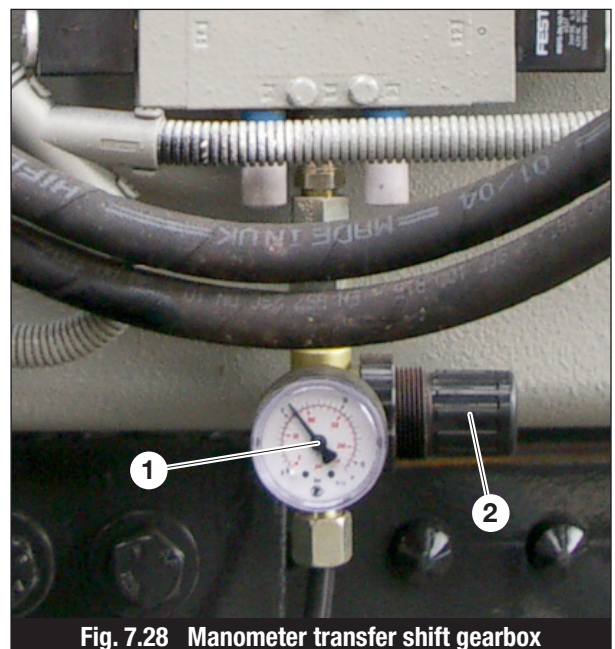

Fig. 7.28 Manometer transfer shift gearbox



## 7.6 Instructions for pump operation



### NOTE:

The maximum conveying pressure must not exceed the pressure listed on the serial plate or in the test book.

- Mix the concrete in the mixer truck at full power and the highest speed, and check that the concrete is evenly mixed. After addition of concrete additives (accelerant, retardant) continue to mix for a further 4 minutes on site.

### 7.6.1 Instructions for pumping

- Immediately before starting pumping, with the agitator running, fill the hopper with several buckets of thin watery concrete, and send through two sponge balls in advance. Pump slowly, until a full stream of concrete emerges from the discharge hose.
- If the conveying pipework is short and clean, immediately before starting pumping, with the agitator running, fill the hopper with several buckets of laitance (cement-water mixture), and send through two sponge balls in advance, so that the laitance wets the whole periphery of the pipework. Pump slowly, until a full stream of concrete emerges from the discharge hose.
- For newer and longer conveying pipework the frictional resistance is greater, so make sure you pump sufficient laitance through.
- Fill the hopper with concrete from the silo or the mixer truck and keep pumping with the concrete pump.



### NOTE:

If the pipework is rusted on the inside (high conveying resistance), do not increase the conveying quantity until you have pumped several m<sup>3</sup> continuously.

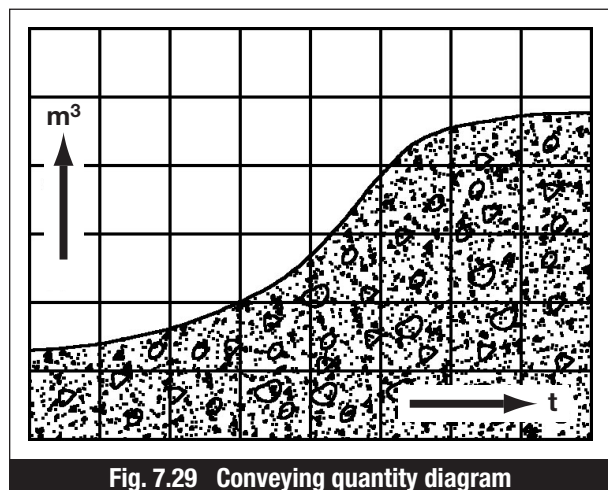



- If a blockage occurs, immediately pump the concrete back into the hopper and mix it. Only switch over to forward conveying when the conveying cylinder and transfer tube are correctly switching over automatically. Carefully start pumping through again.

### 7.6.1.1 Causes of blockages

- Laitance too thin or with insufficient cement
- Insufficient laitance used
- S-valve leaking (wear plate worn and ring too large: replace the parts)
- Leaking pipework (concrete bleeds out)
- Set concrete residues in the transfer tube or conveying pipes
- Unsuitable concrete composition

### 7.6.2 General instructions for pumping

- Whilst pumping, be sure not to draw any air in, since compressed air can emerge violently at the discharge hose, causing concrete to spray out. Therefore keep the hopper filled at least up to the level of the agitator shaft.
- When pumping, keep the agitator running.
- Avoid long pauses during which no concrete is pumped.

#### ***During pauses in pumping the concrete, observe the following points:***

- Do not leave the conveying pipework under pressure
- Depressurise the conveying pipework by briefly reversing the pump
- Keep the concrete moving by briefly pumping through and back
- If there is a long pause in pumping, pump the concrete back into the hopper and mix it again before pumping it through the conveying pipework.

If the distributor boom whips around, determine the cause of this.

#### ***The following causes may lead to this:***

- The outriggers may have moved – repeat the outrigger set-up procedure, see section 7.3.4

**WARNING: Before restarting, determine the reason why the outriggers had moved.**



- The pump speed is too high, reduce the pump speed
- The distribution boom is badly positioned, move the distribution boom to a better position  
Example of a badly positioned distribution boom: Boom fully extended, element 4 vertical

### 7.6.3 Instructions for pumping (depending on the material to be pumped)



#### NOTE:

- ☞ **Only ever use pumpable concrete!**
- ☞ **If you are unsure, contact the concrete manufacturer.**

- If pumping concrete that is hard to pump, the agitator shaft should be visible at all times!  
Difficult concrete (extremely stiff, low-sand mixtures, light-weight concrete etc.) will pump better when the hopper is filled only to the lower edge of the agitator shaft. This procedure means that air will be drawn by the concrete pump into the conveying cylinder and the concrete will be conveyed in air plug mode. Caution, blockages may occur!
- The pressure should be relieved in the conveying pipework by brief reversal of the pump (2-3 strokes) during pauses in conveying. Frequently pump back and forwards. Never allow the conveying pipework to stand under pressure.
- If the concrete is very fluid, with a high proportion of large gravel, and tends to bleed from the conveying pipework, always pump out into the hopper during pauses in pumping.
- During longer pauses pump the concrete back into the hopper, mix it and pump it through again.
- During longer pauses in pumping, switch off the drive engine, so that its vibrations do not cause the concrete to separate out. At intervals of 10-15 minutes, pump the concrete back and forth.
- Never force concrete that has separated out, or concrete that is lumpy because it is beginning to set, through the conveying pipework.
- Especially with concrete that has a low capacity for retaining water (tendency to bleed) avoid pauses when working at high throughputs, and when restarting conveying be sure to let the pump run long enough for the transfer tubes on both sides to be filled. Only then switch over to forwards conveying again.
- Air inclusions in the conveying pipework can be hazardous, since compressed air can emerge violently at the discharge hose, causing concrete to spray out explosively.  
Air inclusions occur particular when pumping through by sucking in air when the hopper is insufficiently filled with concrete and when the conveying pipework has been extended.
- The characteristics of the concrete must not be changed in any way.





### 7.6.4 Instructions for pumping (depending on the machine)

- The max. running speed of the diesel engine must under no circumstances be exceeded, since otherwise the hydraulic pump will overspeed. The permissible speeds can be found on the machine data sheet.
- Pay attention if the piston strokes are shortened and if necessary take action to counteract this (see Chapter 8 “Trouble-shooting”).
- If during continuous operation under heavy loading the oil temperature exceeds 80 °C, the indicator lamp will light (Item 4, Fig. 5.2). Immediately top up the water tank with cold water.

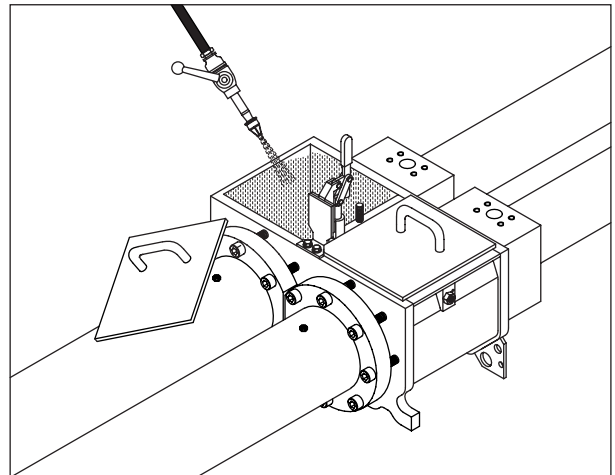

Fig. 7.30 Water in the wash-out tank

- After periods of heavy loading of the engine, never just switch it off, allow it to idle and cool down, at a diesel engine speed of approx. 1,000 rpm. This is particularly important for turbo diesel engines.
- Set the engine speed to more than the minimum speed (500-700 rpm).
- Damage due to operator error is not covered by the **WAITZINGER** warranty.
- If the temperature continues to rise, change the water continuously. Discover the cause of the overheating and rectify it. If the oil temperature rises above 40 °C the thermostatically controlled fan under the master control block will cut in.
- Under no circumstances spray the oil tank with water. This usually leads to a build-up of condensate water and damage to the hydraulic pump. If the cooling measures are insufficient, direct a water jet on to the drive cylinder (hydraulic cylinder) as shown here.

All pumps have a thermo-electric cut-out. If the oil temperature exceeds 80 °C the pump will be switched off automatically and the red indicator lamp on the control cabinet or control desk (Item 4, Fig. 5.2) will light up.

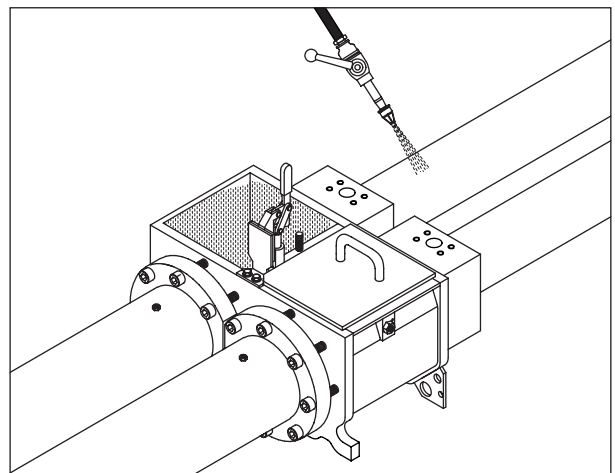

Fig. 7.31 Water on the drive cylinder



### 7.6.4.1 Measures to reduce the oil temperature

- Switch the pump to the “OFF” (11) position. The indicator lamp “Control System ON” (3) on the control panel will go out.
- Do not switch the engine off, the oil cooler must remain in operation.
- Renew the water in the water tank.
- When the red indicator lamp “Temperature” (4) has gone out, switch the pump on again. Continue to pump but at a lower power.
- When pumping is complete, establish the cause for the oil overheating and rectify it.
- The temperature sensor for the thermo-electric cutout is located in the hydraulic oil tank.



Fig. 7.32 Control panel desk

## 7.7 Cleaning the conveying pipework

### 7.7.1 General

- Do not use any aggressive cleaning additives for cleaning the conveying pipework
- Put the remote control pendants in a dry place.
- Follow the directions of the vehicle manufacturer
- Dispose of the cleaning materials according to regulations

### 7.7.2 Suction cleaning

- Pump out the agitator hopper down to the upper edge of the agitator shaft, then switch the pump off.
- Push a wetted cleaning sponge (cube) into the outlet of the discharge hose.
- Pull the cleaning sponge back through the boom by operating the pump in “reverse feed”; strike the conveying pipework with light hammer blows until the cleaning sponge has passed that point (the hollow ring is recognisable).

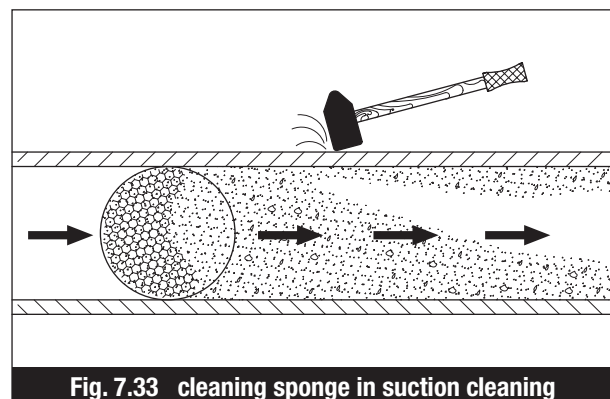

Fig. 7.33 cleaning sponge in suction cleaning



- Switch off the pump.
- Open the hinged base and retrieve the sponge.
- On long conveying pipework runs, repeat the cleaning process. One back suction run is not enough!
- If the protective grill has a safety cut-out, agitator and S-valve come to a halt as soon as the protective grill is opened. When cleaning, briefly shut the protective grill, let the pump run through one cycle, open the protective grill again. A protective grill that is bolted in position remains in position throughout cleaning.
- Remove any remaining material by opening the cleaning valve. Carefully spray the S-valve, hopper, conveying cylinder and water tank until they are clean. Clean the rest of the machine and spray it with formwork release oil.
- If there is a risk of frost, drain the wash-out tank, water tank and water pump. The wash-out tank should also be drained at normal temperatures during long pauses in pumping, overnight and at weekends.

### 7.7.3 Cleaning with pressurised water.

Cleaning the machine with pressurised water is a method well proven in practice.

- Empty the hopper as far as possible.
- Switch the pump to “Suck” mode using rocker switch (Item 11, Fig. 7.32) and pump 1 or 2 strokes to depressurise the conveying pipework.
- Switch off the pump.
- Drain out the remaining material by opening the cleaning valve, see section 7.7.4. When conveying upwards, close the blocking slide and open the cleaning port in the rising pipe.
- Switch the pump on again, in “Suck” mode, and carefully wash down the conveying pipe with the spray jet, working through the cleaning port. Take care that the hose is not cut through when the S-valve operates. Keep spraying the conveyor pipework until clear water emerges from the conveying cylinders.
- Switch off the pump.
- Clean the hopper and all the parts that come in contact with the material with the spray hose also.
- Push 2 or 3 cleaning sponges soaked with water into the cleaning port and the seal the cleaning port tightly.

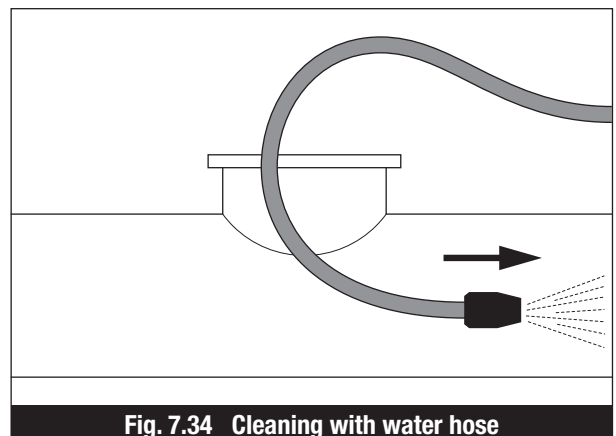



- Close the cleaning valve and fill the hopper with water.
- Switch the pump on again, in “Suck” mode. Push the material in the conveying pipework forwards to the discharge.  
If a single filling of the hopper is insufficient for a long pipe run, switch the pump off before air is drawn in, and fill the hopper again with water. Then continue with the discharge of the material until the cleaning sponges emerge from the discharge hose.

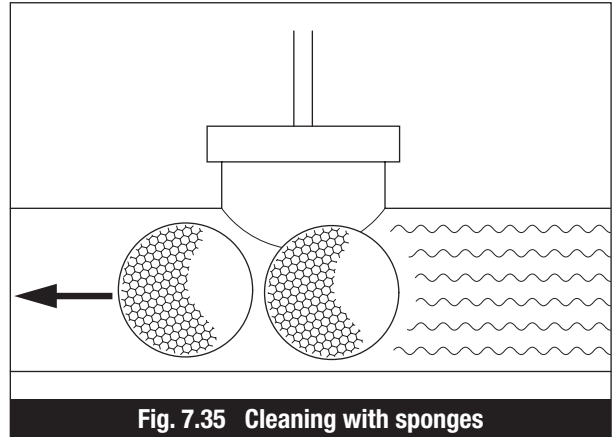

- Take care that the water flowing from the discharge hose does not flow into the formwork.
- Suck the water back into the hopper by reversing the pump.
- If the protective grill has a safety cut-out, agitator and S-valve come to a halt as soon as the protective grill is opened. When cleaning, briefly shut the protective grill, let the pump run through one cycle, open the protective grill again. A protective grill that is bolted in position remains in position throughout cleaning.
- Remove the remaining water by opening the cleaning valve. Carefully spray the S-valve, hopper, conveying cylinder and wash-out tank until they are clean.
- Clean the rest of the machine also, and spray it with formwork release oil.

See further information in the separate documentation supplied by the manufacturer.



### NOTE:

**If there is a risk of frost, drain the wash-out tank, water tank and water pump. The wash-out tank should also be drained at normal temperatures during long pauses in pumping, overnight and at weekends.**



### 7.7.4 Draining the remaining concrete

The remaining concrete can be drained through the drain valve under the hopper.

- Strike the cover (Item 1, Fig. 7.36) of the drain valve lightly with a hammer to open it. If the cover is too slack or too stiff, adjust the clamping screws (Item 2, Fig. 7.36).
- Collect the remaining concrete in a suitable container or on plastic sheeting, for reprocessing or disposal.
- Observe the safety instructions set out the Chapter 2 “Safety instructions”.

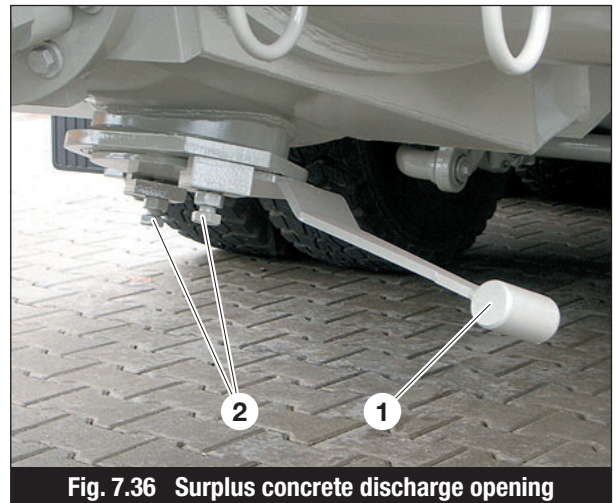

Fig. 7.36 Surplus concrete discharge opening

## 7.8 Water tank

### 7.8.1 Filling up / topping up with water by removing the cover

- Close all ball valves.
- Unscrew the cover (1) on the rear outrigger.
- Fill with water of a suitable quality (clean water without foreign bodies such as sand).
- Watch the water level indicator (2).
- Screw the cover back in place.

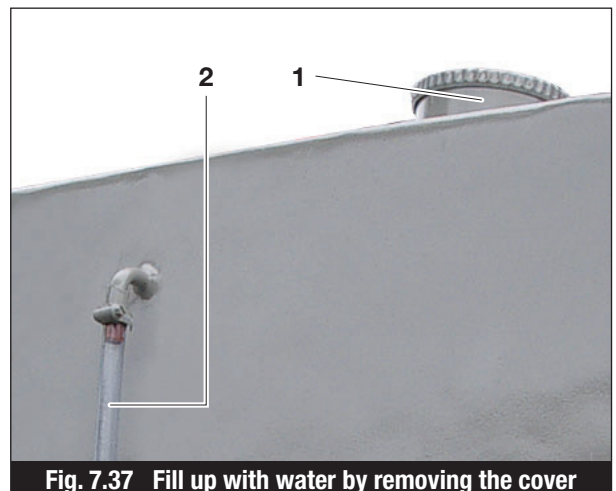

Fig. 7.37 Fill up with water by removing the cover

### 7.8.2 Filling with water using the C-coupling

- Connect the water hose to the C-coupling (Item 1, Fig. 7.38).
- Open the ball valve (Item 2, Fig. 7.38)
- Start filling with water; watch the water sight hose (Item 2, Fig. 7.37).
- Keep filling with water until water emerges from the filler opening.

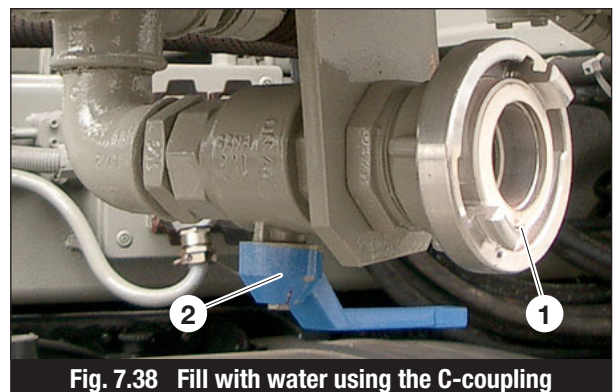
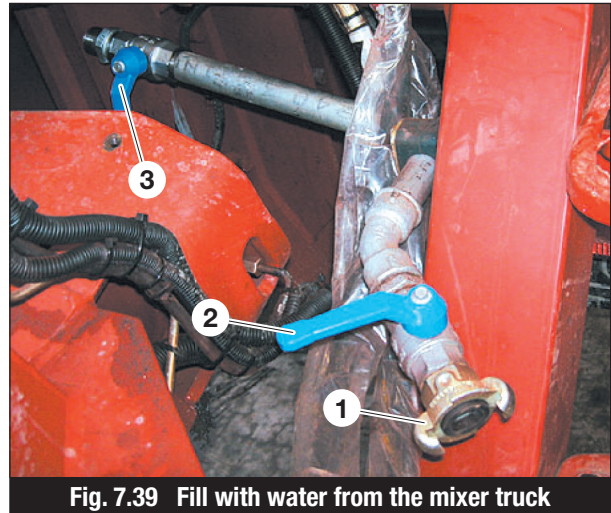

Fig. 7.38 Fill with water using the C-coupling



### 7.8.3 Filling with water from the mixer truck

- Connect the water hose to the Geka-coupling (Item 1, Fig. 7.39).
- Open the ball valve (Item 2, Fig. 7.39)
- Start filling with water; watch the water sight hose (Item 2, Fig. 7.37).
- Keep filling with water until water emerges from the filler opening.



### 7.8.4 Operation in winter

- The machine must be standing level; level the machine using the circular levels (Item 1, Fig. 5.5 and Item 3, Fig. 5.6).
- Completely drain all water by opening all ball valves (Item 2, Fig. 7.38 and Item 2, Fig. 7.39).
- Drain the wash-out tank



## 8. Trouble-shooting

### 8.1 General information

The actions described in this chapter for trouble-shooting should be employed if during operation deviations from normal performance are found.

Trouble-shooting should be performed based on the following table.

Only skilled technical staff should investigate the causes of faults and implement measures to rectify the fault.

If the fault cannot be rectified, contact **WAITZINGER** customer service.

### 8.2 Tracing faults

Fault	Cause	Remedy
Gearbox does not shift to "Pump position".	Vehicle ignition not switched on.	Switch on the ignition.
	Clutch was not disengaged.	Disengage the clutch and engage the required gear.
	Pressure in vehicle compressed air system too low.	Allow the engine to run until it has built up sufficient pressure.
	Pneumatic valve iced up.	De-ice the muffler on the pneumatic valve.
	Solenoid on pneumatic valve defective.	Check solenoids and wiring. The valve can also be actuated with a screwdriver.
	Fuse in vehicle blown.	Establish cause and rectify it. Replace fuse.
No indicator lamps lit on the controls (green LED on desk, and Emergency Stop not illuminated).	Vehicle ignition not switched on.	Switch on the ignition.
	Gearbox in driving position.	Change the gearbox over.
	Gearbox limit switch defective.	Replace gearbox limit switch. (Short-term remedy: Bridge the two contacts on the plug).
	Main fuse (battery) or fuse F1/F2 blown.	Establish cause and rectify it. Replace fuses.



<b>Fault</b>	<b>Cause</b>	<b>Remedy</b>
Emergency Stop indicator lamp flashing.	Emergency Stop button has been pressed.	Establish why the Emergency Stop button was pressed and remedy the cause. Release the Emergency Stop and restart the controls with the horn, see section 7.2.2.
	Selector switch set to remote control.	Release remote control Emergency Stop, or change over the selector switch on the desk, and start the controls with the horn.
	Broken cable or defective Emergency Stop switch.	Have fault rectified by <b>WAITZINGER</b> customer service.
Pumping or sucking does not start, no pressure available.	Selector switch in position "Desk".	Move selector switch to position "Remote control", operate horn.
	Grill open.	Close grill. Check limit switch.
	"Pump ON" was selected when the controls were switched on using the horn.	Switch the pump off and restart it.
	Engine not running.	Start the engine.
	Vehicle gearbox in neutral.	Select a gear, see section 7.2.1.
	Stroke rate potentiometer at "0".	Set a higher value, see section 7.2.1.
	Emergency Stop button has been pressed.	Establish why the Emergency Stop button was pressed and remedy the cause. Release the Emergency Stop and restart the controls with the horn, see section 7.2.2.
	Hydraulic oil too hot.	Let the hydraulic system cool down, see section 7.6.4.
Spool valve defective.	Check valve and solenoid, and have part replaced if necessary by <b>WAITZINGER</b> customer service.	





Fault	Cause	Remedy
	<p>Pressure relief valve defective.</p> <p>Controls defective.</p>	<p>Check valve and solenoid, and have part replaced if necessary by <b>WAITZINGER</b> customer service.</p> <p>Check fuses F9 to F12. and replace if necessary.</p> <p>Set back-up function to position "A".</p> <p>Immediately on finishing work have the fault rectified by <b>WAITZINGER</b> customer service.</p>
<p>Pumping or sucking does not at maximum pressure.</p>	<p>Blockage in the conveying pipework.</p> <p>Defective sensor on drive cylinder.</p> <p>Spool valve defective.</p>	<p>Suck back and establish the cause of the blockage, see section 7.6.1.1.</p> <p>Set back-up function to position "B". Replace the defective sensor at the earliest opportunity.</p> <p>Check valve and solenoid, and have fault rectified if necessary by <b>WAITZINGER</b> customer service.</p>
<p>Concrete delivery from the pump is too little or is irregular.</p>	<p>Incorrect gear or stage engaged in the vehicle gearbox.</p> <p>Vehicle engine speed too low.</p> <p>Concrete pump sucking in air.</p> <p>Concrete mixture unsuitable for pumping.</p>	<p>Engage the correct gear.</p> <p>Increase the speed. Check the settings.</p> <p>Inform the mixer truck driver that the hopper must always be filled to the agitator shaft at least, see section 7.6.2. Check the conveying piston for wear.</p> <p>Use only "pumping concrete", see section 7.6.3.</p>



<b>Fault</b>	<b>Cause</b>	<b>Remedy</b>
	Incorrect settings in the controls.	Have the settings checked by <b>WAITZINGER</b> customer service.
	S-valve stiff.	Check S-valve settings, check wear plate and ring for heavy wear or fracture, and check the S-valve bearings.
Concrete pump short strokes.	Back-up function B switched on.	Switch off rotary switch (Item 2, Fig. 5.7). Switch on the pressure switch, see section 7.5.4.
	Piston rings in drive cylinder worn.	Have piston rings replaced by <b>WAITZINGER</b> customer service.
Outrigger does not extend.	Incorrect switch setting.	Set selector switch (Item 14, Fig. 5.2) to position "Desk" or set remote control (Item 8, Fig. 5.12) to position "Outriggers".
	Safety switch on the outrigger has not been pressed.	Set safety switch (Item 3, Fig. 5.5) or Item 1, Fig. 5.6).
	Engine not running.	Start the engine.
	Vehicle gearbox in neutral.	Select a gear, see section 7.2.1.
	Pre-selector valve not actuated.	Check solenoid and wiring. Actuate the pre-selector valve "Outrigger" manually. Seek advice from <b>WAITZINGER</b> customer service on this point.
	Pressure setting too low at the outrigger valve.	Check pressure setting shown on the data sheet, adjust it if necessary. Clean the pressure relief valve. Seek advice from <b>WAITZINGER</b> customer service on this point.
	Outrigger catch does not open.	Lubricate the outrigger catch, if necessary disassemble it and clean it, replace the seals and d burr the edges. Seek advice from <b>WAITZINGER</b> customer service on this point.



Fault	Cause	Remedy
<p>The outrigger moves of its own accord.</p>	<p>Releasable non-return valve dirty.</p>	<p>Have valve cleaned or replaced by <b>WAITZINGER</b> customer service.</p>
	<p>Cylinder seal worn.</p>	<p>Have seal replaced by <b>WAITZINGER</b> customer service.</p>
	<p>Cylinder distorted by over-pressure.</p>	<p>Check valves for operation. Replace the cylinder. Seek advice from <b>WAITZINGER</b> customer service on this point.</p>
<p>The boom will not move.</p>	<p>Incorrect switch setting.</p>	<p>Set selector switch (Item 14, Fig. 5.2) to position "Remote control" or set remote control (Item 8, Fig. 5.12) to position "Boom".</p>
	<p>Engine not running.</p>	<p>Start the engine.</p>
	<p>Vehicle gearbox in neutral.</p>	<p>Select a gear, see section 7.2.1.</p>
	<p>Emergency Stop button has been pressed.</p>	<p>Establish why the Emergency Stop button was pressed and remedy the cause. Release the Emergency Stop and restart the controls with the horn, see section 7.2.2.</p>
	<p>Radio remote control not operational.</p>	<p>Check transmitter battery charge. Restart the radio remote control (horn). Change the frequency. Use cable remote control instead.</p>
	<p>Pre-selector valve not actuated.</p>	<p>Check solenoid and wiring. Operate pre-selector valve manually. Seek advice from <b>WAITZINGER</b> customer service on this point.</p>
	<p>Insufficient hydraulic oil.</p>	<p>Stop engine immediately and top up with hydraulic oil.</p> <p><b>WARNING:</b>  The boom cylinder must be bled. Seek advice from <b>WAITZINGER</b> customer services on this point.</p>



Fault	Cause	Remedy
	Dirt in the hydraulic system.	Change the filter and have <b>WAITZINGER</b> customer service clean out the entire system.
	Nozzle in "Load sensing pipe" closed (from 42 m boom).	Have nozzle cleaned by <b>WAITZINGER</b> customer service.
The boom will moves only slowly.	The "50/100%" switch is in the "50%" position.	Set the switch (Item 10, Fig. 5.12) to the "100%" position.
	Incorrect valves settings.	Have the settings checked by <b>WAITZINGER</b> customer service.
	Incorrect gear or stage engaged in the vehicle gearbox.	Engage the correct gear, see section 7.2.1.
	Check pressure setting at the boom block is too low.	Check pressure setting shown on the data sheet, adjust as necessary. Clean the pressure relief valve. Seek advice <b>WAITZINGER</b> customer service on this point.
	Hydraulic pump defective.	Have pump replaced by <b>WAITZINGER</b> customer service.
Individual boom movements do not operate.	Solenoids in the boom control block defective.	Have solenoids and wiring checked or replaced by <b>WAITZINGER</b> customer service.
Element A does not rise.	Sensor on the boom mount is activated.	Have sensor replaced by <b>WAITZINGER</b> customer service.
Slewing not operational.	Boom is at the limit of travel.	Slew it in the opposite direction.
	Boom "Slew" limit switch or solenoid at the boom control block defective (from 42 m boom).	Have the limit switch or solenoid replaced by <b>WAITZINGER</b> customer service.
The boom moves although no no element is activated.	Dirt in the load retention valve.	Clean the load retention valve at the boom cylinder. Set the pressures to the data sheet values. If necessary, replace the valves. Seek advice from <b>WAITZINGER</b> customer service on this point.



Fault	Cause	Remedy
	Seal in boom cylinder worn.	Have seal replaced by <b>WAITZINGER</b> customer service.
	Book cylinder distorted by excessive pressure.	Rectify the cause and replace the cylinder. Seek advice from <b>WAITZINGER</b> customer service on this point.
"Slew" operation too slow, or or does not move.	Pressure setting too low.	Check pressure setting to data sheet, and adjust. Clean the pressure relief valve. Seek advice from <b>WAITZINGER</b> customer service on this point.
	Machine inclination too great.	Reduce the inclination, see section 7.3.4.
	Ball bearing slewing rim insufficiently lubricated.	Lubricate the ball bearing slewing rim.
	Slewing motor worn.	Have motor replaced by <b>WAITZINGER</b> customer service.
The boom slews although "Slew" not activated.	Brake in slewing drive worn.	Have the brake linings replaced by <b>WAITZINGER</b> customer service.
Agitator does not operate.	Grill open.	Close grill.
	Water pump also running.	Switch off the water pump.
Water pump does not operate.	Concrete too stiff, or setting in the hopper.	Empty the hopper and clean it.
	Pressure setting at the agitator control block is too low.	Check pressure setting to data sheet, adjust as necessary. Clean the pressure relief valve. Seek advice from <b>WAITZINGER</b> customer service on this point.
Water pump does not operate.	Water tank empty.	Fill up with water.
	Agitator switched on.	Switch the agitator off using the control lever (Item 5, Fig. 5.3).



Fault	Cause	Remedy
	<p>Pressure setting at the agitator control block is too low.</p> <p>Dirt in the water pump.</p> <p>Axial play in the pump shaft incorrect.</p>	<p>Check pressure setting to data sheet, adjust as necessary. Clean the pressure relief valve. Seek advice from <b>WAITZINGER</b> customer service on this point.</p> <p>Disassemble the water pump and clean it. See separate user manual from the manufacturer.</p> <p>Undo the coupling and adjust to the mid value.</p>
Lubrication system does not operate.	<p>Fuse blown.</p> <p>Pump switched off.</p> <p>Grease too stiff.</p> <p>Lubrication point blocked.</p> <p>Lubrication distributor blocked.</p> <p>Pump impeller defective.</p>	<p>Replace fuse.</p> <p>Switch the pump on.</p> <p>Replace grease with suitable grease, see Figure 9.5.</p> <p>Clear the blockage at the lubrication point.</p> <p>Replace the grease up to the lubrication distributor and replace the lubrication distributor.</p> <p>replace pump impeller.</p>



## 9. Maintenance & Inspection

### 9.1 General information

The truck-mounted concrete pump must be thoroughly cleaned, maintained and inspected at regular intervals. All parts of the machine should be checked that they are in good condition and safe working order. The maintenance actions are listed in the Maintenance Schedule, section 9.4.



#### **WARNING:**

- ☞ Maintenance and inspection work must always be carried out when the truck-mounted concrete pump is stopped and switched off.
- ☞ The adjacent notice must be placed in a suitable place where it is easily visible.



#### **DANGER:**

Work on the hydraulics, pneumatics, electrics and electronics must only be performed by suitably trained skilled staff.

Further information on the truck part of the vehicle can be found in the separate vehicle manufacturer's user manual.

### 9.2 Safety instructions for maintenance and inspection

- ☞ Maintenance and inspection of the truck-mounted concrete pump must only be carried out by authorised staff.
- ☞ Repair work must only be carried out by authorised skilled staff of the manufacturer.
- ☞ Maintenance and inspection work must be carried out precisely in accordance with the specifications and instructions in this maintenance section.
- ☞ Make sure that the user manual for the truck-mounted concrete pump, the maintenance and special tools and fixtures for it, the oilcans and grease guns for lubrication and the cleaning and lubrication media are always kept in the places provided for them.
- ☞ Used cleaning materials must be removed from the truck-mounted concrete pump and placed in a specially designated container (fire hazard!). The use of highly flammable materials (e.g. petrol) is prohibited - VBG 1 § 43 and 44!



### NOTE:

Consumables such as gearbox oil used during maintenance, repair and oil change should be collected in suitable containers and disposed of in accordance with regulations (to EC directive 75/439/EWG and statutory instruments under §§ 5a, 5b AbfG and AltöIV).



- ☞ Electrical control equipment, resistors and contactors should be kept clean and cleaned as required.
- ☞ Check electrical cables for damage to the insulation.
- ☞ Check mechanical components for wear, deformation, crushing, cracks, breakage, corrosion and secure mounting.
- ☞ Regularly check all pipes, hoses and screwed connections for leaktightness and for externally evident damage.
- ☞ Fluids which emerge at high pressure can be hazardous.

### 9.2.1 Lubricants and solvents



### WARNING:

- ☞ As far as possible, avoid allowing lubricants and solvents to contact the skin.
- ☞ Store fluids, especially hydraulic oils and also engine oils, lubricants and liquefied or compressed gaseous products, only in the containers legally prescribed for them.
- ☞ These should carry appropriate warning notices identifying their contents.
- ☞ Comply with all warning notices.
- ☞ When handling these materials wear protective clothing at all times (skin, eyes, hand and foot protection).
- ☞ Used protective clothing must be placed in sealed plastic sacks after wearing.







### 9.2.2 Sealing rings (containing fluorine)



#### **WARNING:**

- ☞ Always wear protective clothing when removing the remains of sealing rings.
- ☞ Fluorine is contained in Viton sealing rings, O-rings and flat gaskets.
- ☞ Under normal conditions of use, Viton seals and O-rings are safe to use. However at temperatures in excess of 400 °C they decompose, e.g. if equipment catches fire.
- ☞ The remains of such seals are then extremely aggressive and generally cannot be removed from the skin.



### 9.2.3 Oils and greases



#### **WARNING:**

- ☞ Allergic reactions can arise when handling oils and greases.
- ☞ Use barrier creams and avoid all contact with the skin.
- ☞ Never wash your hands in oil.
- ☞ Hydraulic oil emerging at high pressure can penetrate the skin and cause severe injuries.
- ☞ To avoid severe infections, call a doctor immediately.
- ☞ Dispose of oils and filters in accordance with statutory regulations.
- ☞ Never pour lubricating oil down the public drains.





### 9.2.4 Paints, varnishes and thinners

- ☞ These materials are highly inflammable when applied as sprays and mists.
- ☞ Thinners vapours are heavier than air and create an extremely high explosion hazard.



#### **WARNING:**

- ☞ **Materials soaked in paint, varnish or thinners can ignite spontaneously if they are carelessly thrown into a rubbish bin.**
- ☞ **Do not breathe in paint or thinners mists.**
- ☞ **When painting, ensure good ventilation and never smoke.**
- ☞ **When spraying paint always wear a close-fitting face mask.**
- ☞ **Never allow petrol or paraffin to come into contact with rubber components. Contamination of rubber components with these materials causes them to swell and soften, leading to failure.**
- ☞ **When working with paraffin or petrol, naked flames and smoking are prohibited.**



### 9.2.5 Glues, adhesives and solvents

- ☞ Some vapours from these materials are flammable and/or poisonous if breathed in.
- ☞ Even gases which are not themselves flammable can decompose at high temperatures and release poisonous gases, e.g. when drawn through the glowing tip of a cigarette.
- ☞ Thus the same safety instructions apply as for paraffin and petrol.



### 9.2.6 Battery acid



#### **WARNING:**

- ☞ Battery fluid contains aggressive sulphuric acid. Always wear protective clothing and protective gloves. Handle batteries with care.
- ☞ If any battery acid splashes on to the skin, wash it off immediately with clean water.
- ☞ If any battery acid splashes on to the eye, wash it out immediately with clean water. Then immediately summon a doctor.
- ☞ Because of the risk of an explosion, keep sparks and naked flames away from batteries. Battery acid can catch fire.





### 9.2.7 Safety precautions when charging batteries



#### **WARNING:**

- ☞ Around batteries there is an explosion hazard due to short circuits, sparks or naked flames.
- ☞ Batteries on charge release explosive gas.
- ☞ Switch off the charging power before disconnecting the charging lead plug.
- ☞ When charging in enclosed spaces, ensure good ventilation.
- ☞ Continue to ventilate the room up until an hour after completing the charge.
- ☞ No smoking!
- ☞ Do not place tools on the battery.
- ☞ Disconnect the battery terminals before working on the electrical system.
- ☞ Electric arcs can be life- threatening and cause fires!
- ☞ Do not place anything metallic on the battery.
- ☞ Sulphuric acid is corrosive.
- ☞ When working on the battery always wear safety glasses and protective gloves!
- ☞ Battery fluid contains sulphuric acid.
- ☞ Remove splashes from the skin immediately with soap and water.
- ☞ Immediately summon a doctor if acid splashes the eyes or mucous membranes.



### 9.2.8 Safety instructions for welding work



#### **CAUTION:**

- ☞ Whenever carrying out welding work on the truck-mounted concrete pump, disconnect the battery and unplug all electrical control equipment!
- ☞ Attach the earth connection immediately adjacent to the welding location!

In addition, observe all safety instructions set out in Chapter 2 Safety Instructions!



### 9.3 Tightening torques for screw connections

The following values apply to tightening torques for machine screws to DIN 912, 931 and 934 based on a friction factor of  $\mu = 1.25$  (lightly oiled).

Thread Ø	Tightening torque $M_D$ [Nm]	
	8.8	10.9
M8	23	32
M10	46	64
M12	80	110
M14	125	180
M16	195	275
M18	270	390
M20	385	540
M22	510	720
M24	660	930
M27	980	1.400

**Fig. 9.1 Tightening torque for screw connections**



### 9.4 Maintenance schedule

Certain maintenance work must be carried out on the machine at specified intervals. These intervals are expressed either as numbers of operating hours or as periods of time such as **semi-annually** or **annually**, whichever interval **is reached** earlier.

Before performing the work for any maintenance interval, the maintenance work for all previous maintenance intervals must have been completed.

Maintenance work	Maintenance intervals				
	Daily	After the first 50 operating hours	Weekly	Every 500 operating hours	Every 1,000 operating hours or annually
Check all components for wear, deformation, corrosion and secure mounting.	×				
Check oil, fuel, grease and water levels, top up as necessary. The machine must be standing on level ground at this time.	×				
Check all filter clogging indicators.	×				
Check components that come in contact with concrete, replace worn parts.	×				
Check the wear condition of the conveying pipework by knocking it or by using a wall thickness gauge (see section 9.8) and replace worn parts. The minimum wall thicknesses can be found in the diagram in section 9.8.2.	×				
Check lubrication system for operation.	×				
Lubricate the conveying piston with grease (unless the automatic piston lubrication option is fitted).	×				
Visually check all hydraulic lines and screwed joints for leak-tightness.	×				



Maintenance work	Maintenance intervals				
	Daily	After the first 50 operating hours	Weekly	Every 500 operating hours	Every 1,000 operating hours or annually
Check the attachment of the discharge hose and the security of all snap couplings.	×				
Perform all necessary maintenance work on the truck in accordance with the separate user manual supplied by the manufacturer.		×			
Clean all filters and replace as necessary, see section 9.6.		×			
Check all screw connections against the tightening torque table in section 9.3.		×			
Check the screw connections on the cardan shaft joints.		×			
Change the oil in the boom slewing gearbox and transfer shift gearbox, see sections 9.7.1 and 9.7.2.		×			
Lubricate all grease points on the boom, boom mounting, pump and ball bearing slewing rim, see section 9.5.			×		
Check the oil level in the slewing gearbox.			×		
Make a thorough visual check for damage of all seals on the S-valve and agitator.			×		
Check the adjustment of the S-valve and adjust it as necessary.			×		
After at least 24 hours settling time check the condensation water in the hydraulic oil tank; drain it through the ball valve until hydraulic oil comes out.			×		



Maintenance work	Maintenance intervals				
	Daily	After the first 50 operating hours	Weekly	Every 500 operating hours	Every 1,000 operating hours or annually
Check the operation of all safety equipment such as Emergency Stop, grill and guards.			×		
Check the structural steelwork of the boom, boom mounting and outriggers for cracks.			×		
Completely drain the hydraulic oil, flush out the hydraulic oil tank and fill with the necessary quantity of hydraulic oil, see section 9.7.3.				×	
Replace the filter cartridges in the hydraulic oil tanks for the boom and concrete pump. Clean the magnetic rod.				×	
Check the oil level in the transfer shift gearbox.				×	
Perform a wear check on the S-valve, verify 8 mm wall thickness.				×	
Perform a wear check on the conveying cylinders.				×	
Clean the diesel pre-filter on the vehicle.				×	
Check the pressure setting of the pump and distributor boom against the data sheet, see sections 3.3 and 3.4.				×	
Check engine speed and operation of the pump together with stroke rate against the data sheet, see sections 3.3 and 3.4.				×	
Check that the conveying piston fastenings are tight.				×	





<b>Maintenance work</b>	<b>Maintenance intervals</b>				
	<b>Daily</b>	<b>After the first 50 operating hours</b>	<b>Weekly</b>	<b>Every 500 operating hours</b>	<b>Every 1,000 operating hours or annually</b>
Check all screw connections on the ball bearing slewing rim against the tightening torque table in section 9.3.				×	
Check that the conveying pipework fastenings on the distributor boom are tight.				×	
Clean the air filter casing.				×	
Change the breather filter on the hydraulic oil tank.				×	
Have all mechanical and hydraulic components examined by an expert.					×
Check all safety equipment that is fitted for good condition.					×
Check distributor boom play between the pinion and the ball bearing slewing rim, see section 9.8.5.					×
Check play within the ball bearing slewing rim, see section 9.8.6.					×
Change the oil in the slewing gearbox, see section 9.7.1.					×
Change the oil in the transfer shift gearbox, see section 9.7.2.					×



## 9.5 Lubrication

### 9.5.1 Central lubrication system

Use only greases of NLGL classes 0 to 2. See documentation for the central lubrication system.

#### 9.5.1.1 Checking the central lubrication system

The operation of the central lubrication system must be checked daily. To do this, all grease points should be lubricated once manually.

##### 1. Starting the lubrication system manually

The ignition must be switched on and all Emergency Stop switches released. Set the concrete pump to the setting "Pump". Actuate the lubrication system for approx. 2 sec.



#### **CAUTION:**

- ☞ Check whether the rotor vane on the lubrication pump rotates and sufficient grease is fed in.
- ☞ If grease emerges from the safety valve, no grease points are being lubricated. This fault must be rectified immediately!

##### 2. Checking the grease points on the hopper (Fig. 9.2)

At the bearings of the S-valve no. 2 and no. 3 and agitator no. 4 and no. 5 grease must emerge into the hopper; at S-valve no. 1 grease must emerge into the conveying pipe (the flap elbow must be open).

##### 3. Checking the operation of the lubrication distributor

After waiting no more than 4 minutes the control pin in the lubrication distributor must be seen to move in and out.

##### 4. Checking the lubrication pipes



#### **CAUTION:**

**Immediately replace any defective lubrication pipes!**



Check the lubrication pipes for damage and leak-tightness. All lubrication pipes must be securely connected.

### 5. Checking the grease nipples for manual lubrication

No grease must be leaking from the grease nipples. Either replace the defective grease nipple and non-return valve immediately (or close it off).

### 6. Lubricating “manually”



#### CAUTION:

Before starting work, check that grease is issuing at all grease points, see point 2.

If the central lubrication system is defective, all grease points can be lubricated manually, using a grease gun. This should be performed no less frequently than every 2 hours of operation.

### 7. Blocked grease points

If no grease can be injected into a lubrication point, this problem must be rectified as soon as possible by a **WAITZINGER** customer service fitter.

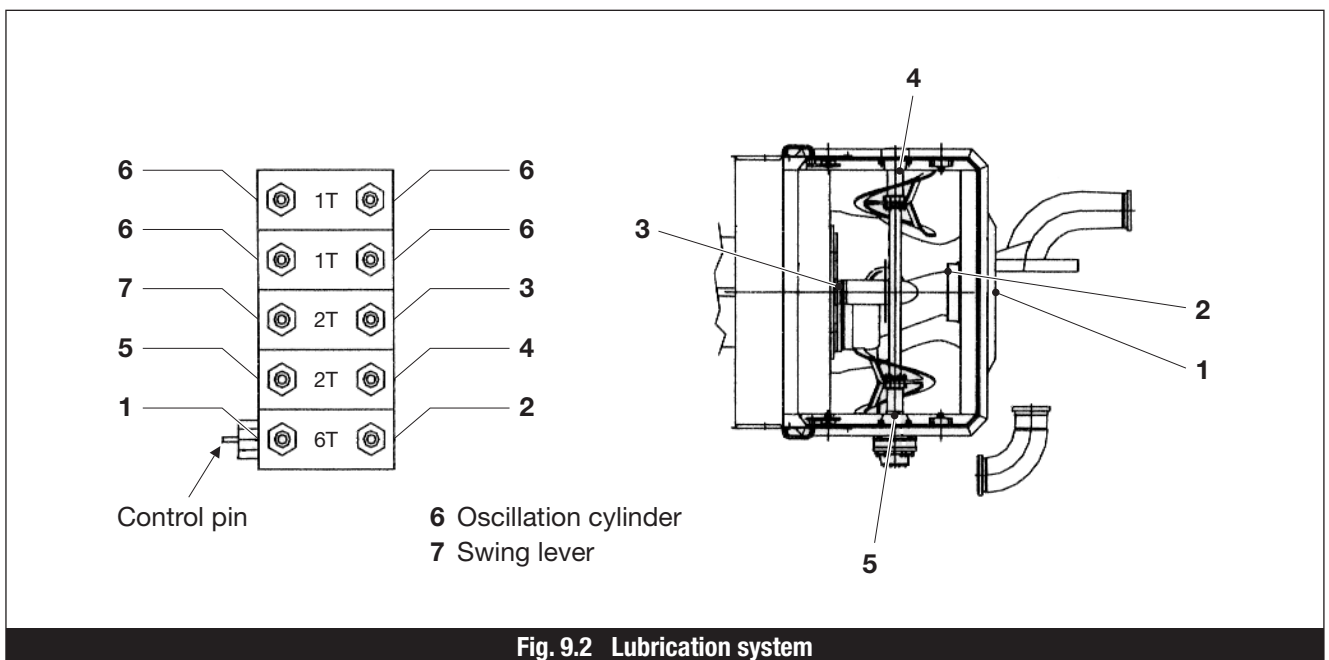

Fig. 9.2 Lubrication system



### 9.5.2 Manual lubrication

An acid-free multi-purpose grease should be used for manual lubrication, see Figure 9.5.

### 9.5.3 Sliding surfaces

Use graphite grease for sliding surfaces, see Figure 9.5.

### 9.5.4 Overview of grease points

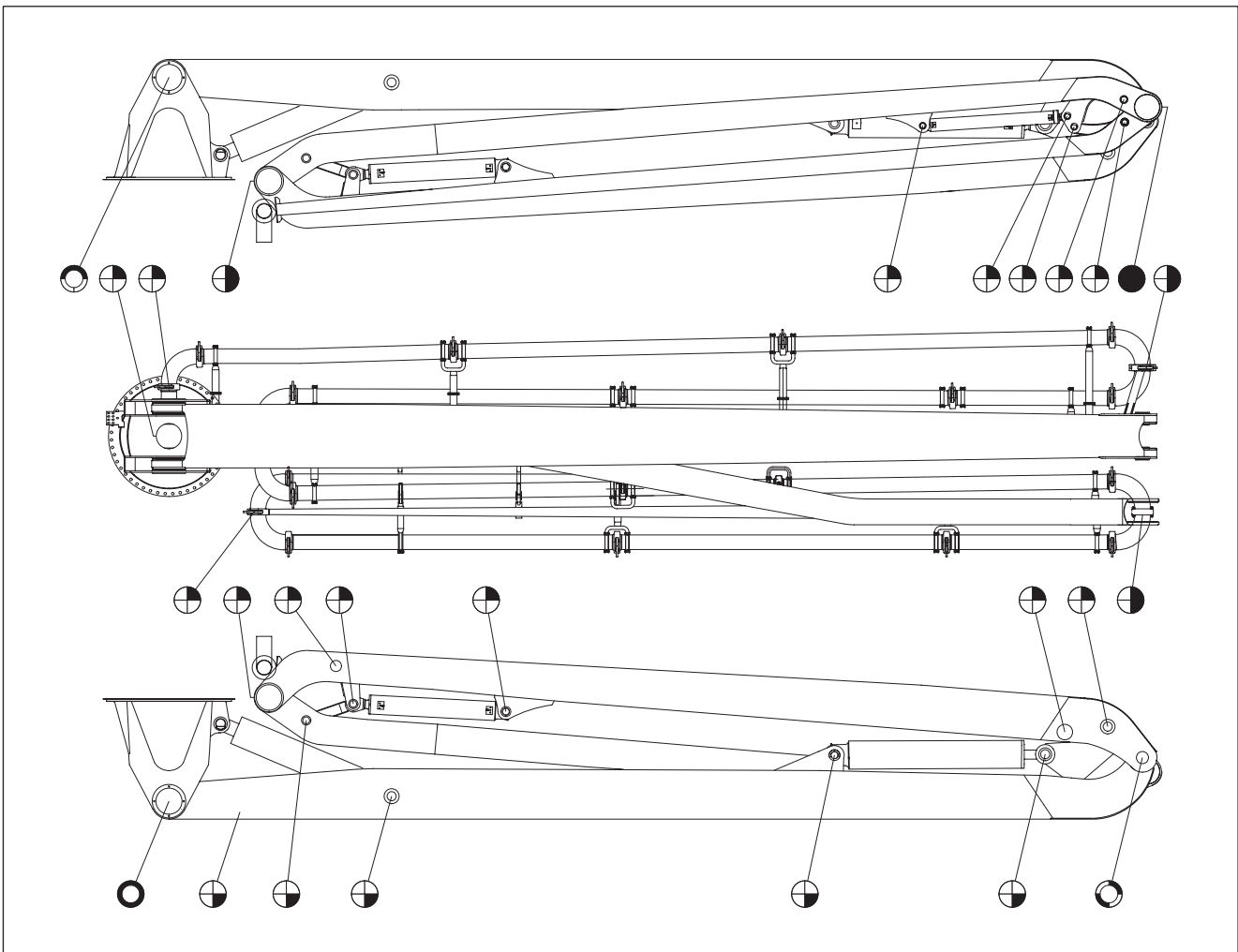

**Fig. 9.3 Grease points overview**

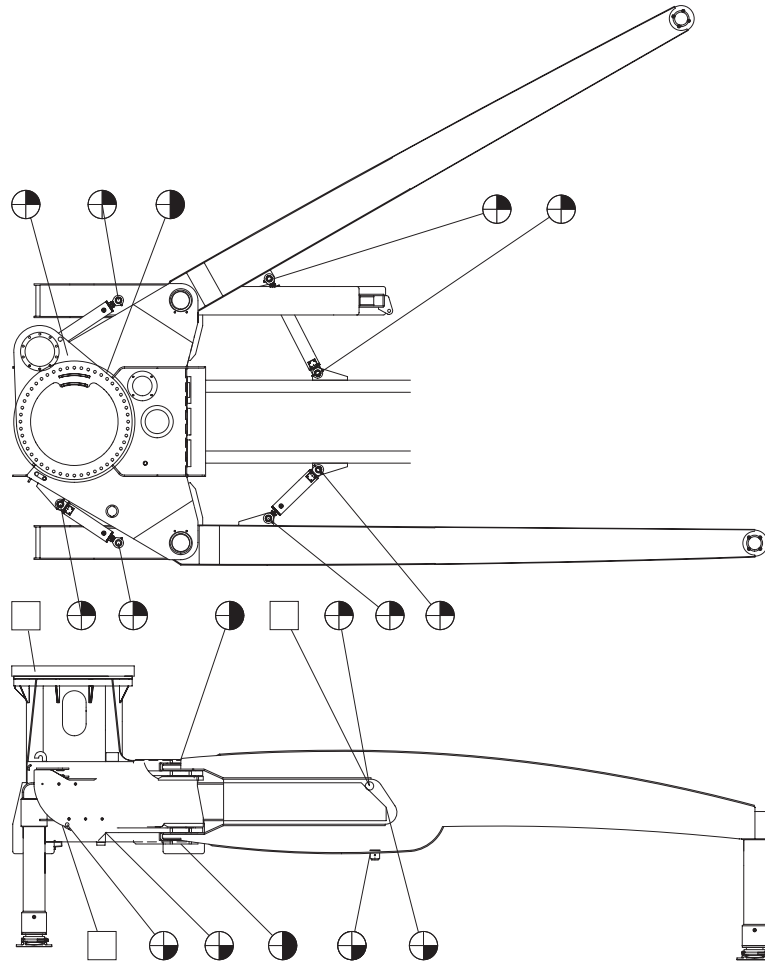

- ⊕ = 1 Schmiernippel
- ⊖ = 2 Schmiernippel
- ⊗ = 2 Schmiernippel, gegenüberliegend
- = 2+2 Schmiernippel, gegenüberliegend
- ⊙ = 2 Schmiernippel auf der Innenseite
- ⊘ = 2 Schmiernippel auf der Innenseite, gegenüberliegend
- ⊚ = 2+2 Schmiernippel auf der Innenseite, gegenüberliegend
- = Flächenschmierung

**Fig. 9.3 Grease points overview Boom control block**



### 9.5.5 Reference tables for hydraulic oils, greases and gear oils

Lubricants suitable for the truck-mounted concrete pump are listed in table below. **WAITZINGER** Takes no responsibility for the quality of the lubricants that are listed, nor for variations in their quality.



#### CAUTION:

- ☞ Hydraulic oils with different characteristics – biologically degradable / mineral-based hydraulic oils – must on no account be mixed!
- ☞ Engine oil data can be found in the separate user manual issued by the vehicle manufacturer.

Manufacturer	Standard » HLP 46 «	Tropic » HLP 100 «
AGIP	Arnica 46 L-HV/46	Blasia S 220
ARAL	Vitam CF 46	Vitam CF 100
BP	Energol HLP 46	Energol HL P10
ELF	Olna 46	Olna 100
ESSO	Nuto H 46	Nuto H 100
FANAL	Salvo MWS 46	Salvo MWS 100
FUCHS	Renolin B 15	Renolin B 30
MOBIL	DTE 25	DTE 27
SHELL	Tellus Öl 46	Tellus Öl 100

Fig. 9.4 Hydraulic oils reference table



The automatic lubrication system can convey greases only up to NLGI class 2 or mineral oils which have at least 40 mm<sup>2</sup>/s (cST) at 40 °C.

**IMPORTANT:** When handling greases be scrupulous about cleanliness. Contaminants remain in suspension in the grease, they do not settle out. They can lead to blockages in the delivery pipes, causing damage to bearings.

	Manufacturer	Designation	Type of saponification	Min. conveying temperature
Conventional greases	AGIP	F1 Grease 24	Ca	–
	ARAL	Mehrzweckfett ZS 1/2	Ca/Li	-20 °C
	AUTOL	Top 2000	Ca	-10 °C
		Top 8000 W	Ca	-20 °C
	BP	Abschmierfett	Ca	–
		C1 Abschmierfett	Ca	-20 °C
	CASTROL	CLS - Grease	Ca/Li	–
	ESSO	Cazar K2	Ca	–
		High pressure grease	Ca	–
	FIAT LUBRIFICANTI	Comar 2	Li	-25 °C
	FINA	Ceran LT	Ca	-20 °C
		Ceran WR2	Ca	–
	FUCHS	FN 745	Ca	-25 °C
		Renocal FN3	Ca	-20 °C
		Renolit HLT 2	Li	-25 °C
	KLÜBER	Centoplex 2 EP	Li	–
	MOBIL	Mobilgrease	Li	-30 °C
	MOLYKOTE	TTF 52	inorg. thinner	-30 °C
OPTIMOL	Longtime PD 2	Li	-20 °C	
	OLIT CLS	Li/Ca	-15 °C	
SHELL	Retinax C	Ca	–	
WESTFALEN	Gresalit ZSA 2	Li	-15 °C	
ZELLER & GMELIN	ZG 450	Li	–	
	ZG 736	Li	–	
Biologically degradable greases	ARAL	BAB EP 2	Li/Ca	–
	AUTOL	Top 2000 Bio	Ca	-25 °C
	AVIA	Biogrease 1	Li	bis 0 °C
	DEA	Dolon E 2	Li	-15 °C
	FUCHS	Plantogel S2	Li/Ca	–
	KLÜBER	Klüberbio M32 - 82	Ca	-20 °C

Fig. 9.5 Greases reference table



As-assembly	Transfer gearbox / Slewing gearbox						Lubrication system							
	Mineral			Synthetic			Low-viscosity grease	Roller bearing Grease						
	Öl - CLP DIN 51517							Öl - PGLP DIN 51502						
Kinematic viscosity in cSt at 40 °C	460	320	220 (standard)	100	15	460	220	100	-	-	-	(standard)	-	-
Ambient temperature in °C	+5 - +46	0 - +40	-5 - +35	-15 - +25	-50 - +10	-15 - +100	-25 - +80	-35 - +60	-20 - +50	-	-35 - +60	-30 - +60	-	-
ARAL	Degol BG 460	Degol BG 320	Degol BG 220	Degol BG 100	-	Degol GS 460	Degol GS 220	-	Aralub FDP 00	-	-	Multi-purpose grease Aralub 1/L 2	-	-
BP	Energol GR-XP 460	Energol GR-XP 320	Energol GR-XP 220	Energol GR-XP 100	Bartran HV 15	Energol SG-XP 460	Energol SG-XP 220	-	Energol HT 00-EP	Energol FG 00-EP	Energol GSF	Multi-purpose grease L 2	Energol LS 2	-
CALYPSOL	UK-Ecubisol ÖI 8140	UK-Ecubisol ÖI 8060	UK-Ecubisol ÖI 8050	UK-Ecubisol ÖI 8030	-	UK-Ecubisynth ÖI PG 460	UK-Ecubisynth ÖI PG 220	-	Calypsol D 6024	Calypsol D 8024	-	Calypsol H 441	Multi-purpose grease Calypsol 20	Calypsol H 729
CASTROL	Alpha SP 460	Alpha SP 320	Alpha SP 220	Alpha SP 100	Alphasyn T 15	Alphasyn T 460	Alphasyn T 220	-	CLS-Grease	-	CLS-Grease	Spheröl AP 2	-	LZV-EP
CHEVRON	NL-Gear Compound 460	NL-Gear Compound 320	NL-Gear Compound 220	NL-Gear Compound 100	Mechanism LPS 15	-	-	-	Dura-Lith. EP Grease 00	-	-	Dura-Lith. EP Grease 2	-	-
DEA	Falcon CLP 460	Falcon CLP 320	Falcon CLP 220	Falcon CLP 150	Astron Z HLP 15	Polydea CLP 460	Polydea CLP 220	-	Glissando 283 EP 00	Orona DR 00	-	Glissando R EP 2	Glissando 20	-
ESSO	Spartan EP 460	Spartan EP 320	Spartan EP 220	Spartan EP 100	Univis N 15	-	Circulation oil S 220	Circulation oil EZL 502	Fibrax EP 370	Fibrax 370	Low-viscosity grease S 420	Beacon 2	Unirex N 2	-
KLÜBER	Klüberoil GEM 1-460	Klüberoil GEM 1-320	Klüberoil GEM 1-220	Klüberoil GEM 1-100	Isotlex MT 30 ROT	Klüberisynth GH 6-460	Klüberisynth GH 6-220	Klüberisynth GH 6-100	Microlobe GB 00	-	Klüberisynth GE 46-1200	Centplex 2 EP	Centplex	Isotlex Topas NCA 52
MOBIL	Mobilgear 634	Mobilgear 632	Mobilgear 630	Mobilgear 627	Mobil DTE 11	Mobil Glygolyle 80	Mobil Glygolyle 30	Mobil Glygolyle 11	Gargolye Fett 1200 W	-	-	Mobilgrease MP	Mobilux 2	Mobiltemp SHC 100
SHELL	Shell Omala Öl 460	Shell Omala Öl 320	Shell Omala Öl 220	Shell Omala Öl 100	Shell Tellus Öl T 15	Shell Tivela Oil SD	Shell Tivela Oil WB	Shell Tivela Oil WA	Shell Spezial Gear box grease H	Shell Tivela Compound A	Shell Tivela Compound A	Shell Alvania Fett G 2	Shell Alvania Fett R 2	Aeroshell Grease 7

Fig. 9.6 Gearbox oils reference table





## 9.6 Changing filters

### 9.6.1 General



#### **DANGER:**

- ☞ Filters may be changed only when the engine is switched off and the hydraulic system is depressurised (accumulator pressure or hydraulic pressure generated by static pressure in the conveying pipework).
- ☞ The distributor boom must be stowed for transport or propped.

- Changing a filter always involves some loss of hydraulic oil. Therefore be sure always to have a container or oil barrel to hand.
- Filters should be changed in a short a time as possible, so that there is the least opportunity for contamination to enter the hydraulic system. Therefore before starting work have the replacement filter element, O-rings, lint-free wipe cloths and petrol for washing down ready to hand.
- After changing the filter, always check the oil level and top up with oil as necessary.



#### **NOTE:**

Do not let hydraulic oil drain into the ground, always use a sufficiently large bowl or container and dispose of it in accordance with the applicable regulations.





### 9.6.2 High-pressure filters for the boom and hydraulic pumps

If the red ring in the clogging indicator (Item 1, Fig. 9.7) is visible, the filter element must be changed:

1. Unscrew the filter casing (2) anti-clockwise.
2. Pull the filter element (3) downwards from the casing (4).
3. Clean the filter casing, replace the O-ring, and grease the thread and O-ring.
4. Fill the filter casing with clean oil.
5. Plug in the filter element.
6. Fit the filter casing and tighten it to approx. 150 Nm.

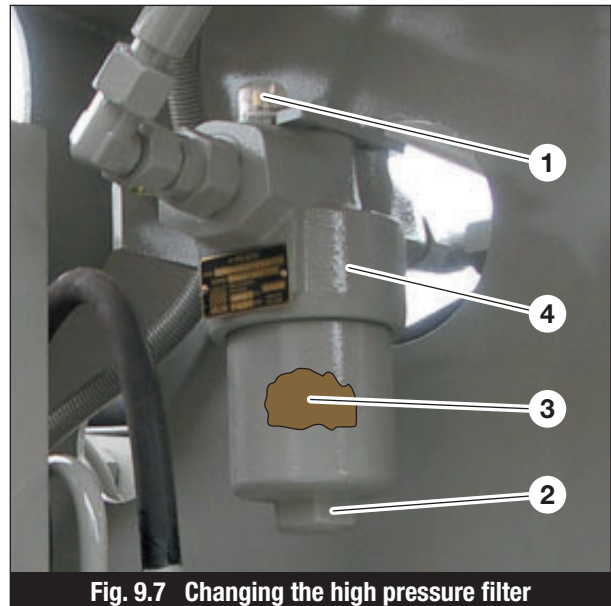

Fig. 9.7 Changing the high pressure filter

### 9.6.3 Return flow filter

If the clogging indicator (Item 1, Fig. 9.8) is in the red zone when the oil is at operating temperature, the filter element must be changed:

1. Have a suitable container ready for the oil filter element, and clean the outside of the filter casing.
2. Undo the 4 screws (3) and place the cover (2) on a clean surface.
3. Take out the filter element (4) with spring and dirt sleeve (5).
4. Twist the dirt sleeve anti-clockwise and pull it off, then thoroughly clean it and fit it to the new filter element.
5. Fit the new filter element into the return flow filter.
6. Fit the spring and cover, secure with 4 screws.
7. Check filter for leak-tightness.

**NOTE:** When changing the return-flow filter, always change the air filter (6) also!

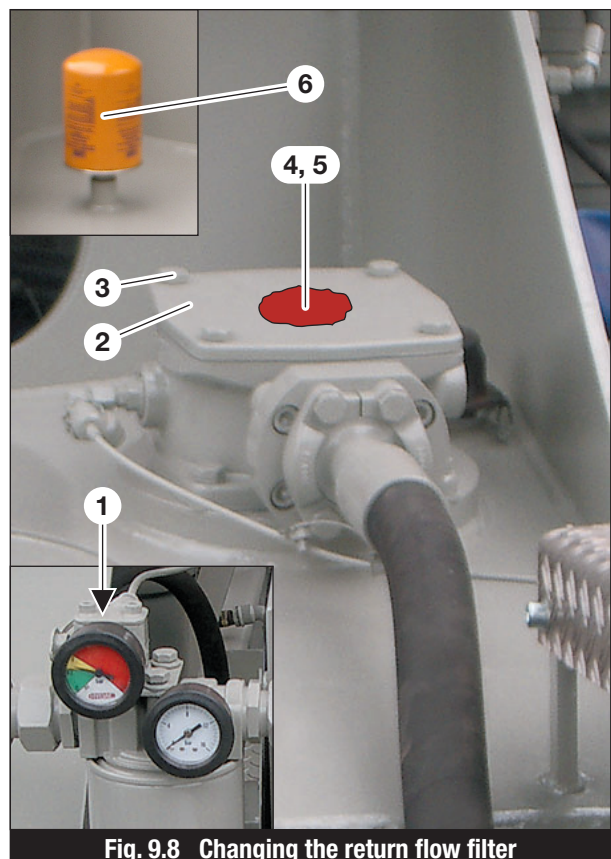

Fig. 9.8 Changing the return flow filter



### 9.6.4 In-line filter cartridge

If the manometer (Item 1, Fig. 9.9) shows a value in excess of 3 bar when the oil is at operating temperature, the filter element must be changed:

1. Turn the filter cartridge (2) anti-clockwise by hand to undo it, and dispose of it correctly.
2. Wet the sealing ring of the new filter cartridge with oil and screw it in clockwise by hand.
3. Check the in-line filter for leak-tightness.

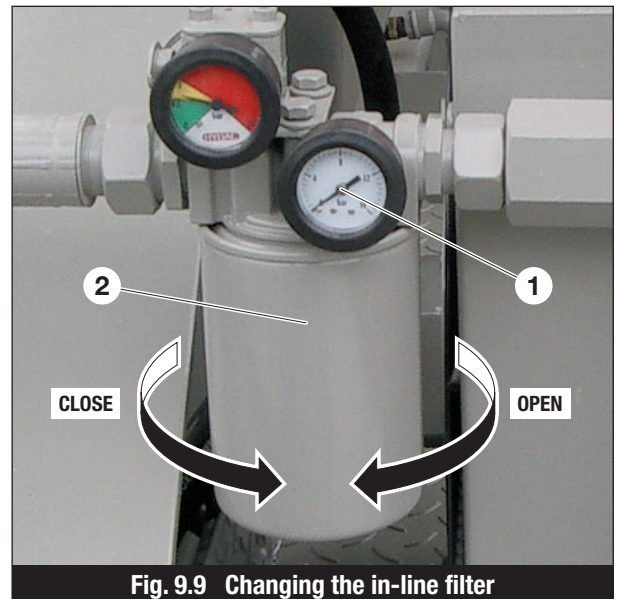

Fig. 9.9 Changing the in-line filter

## 9.7 Changing the oil

### 9.7.1 Changing the oil in the slewing gearbox



#### NOTE:

- ☞ The slewing gearbox has only one oil circuit (oil circuit A).
- ☞ Use only gear oil as shown in the gear oil reference table Fig. 9.6.

Use oil grades / alternative grades as shown in the gear oil reference table Fig. 9.6. Oil capacity 10 litres.

To change the oil in the slewing gearbox, proceed as follows:

1. Remove the breather screw (1) and fully remove the drain plug (2).
2. If the oil was very dirty, it is essential to fill the gearbox completely with flushing oil, and slew the distributor boom for several rotations. This ensures that any deposits of dirt in the gearbox are fully mixed into the oil; after this, repeat point 1.
3. Reinsert the drain plug.
4. Open the air bleed screw (3). Use a funnel to fill the gearbox with oil through the breather screw opening until the oil reaches level A.
5. Screw in the air bleed screw and the breather screw.

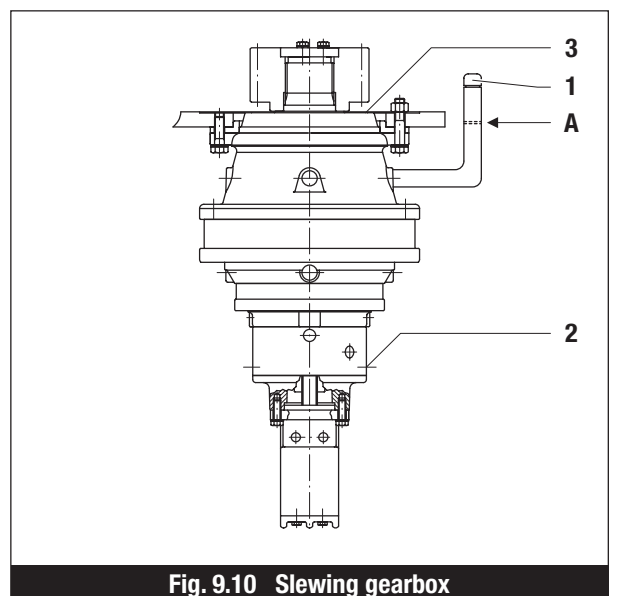

Fig. 9.10 Slewing gearbox



### 9.7.2 Changing the oil in the transfer shift gearbox

Use oil grades / alternative grades as shown in the gear oil reference table Fig. 9.6. Oil capacity 7.3 litres.

To change the oil in the transfer shift gearbox, proceed as follows:

1. Remove the oil level screw (1) and drain plug (2) and let the oil drain into a tray.
2. If the oil was very dirty, it is essential to fill the gearbox completely with flushing oil, and run the hydraulic system for a short period. This ensures that any deposits of dirt in the gearbox are fully mixed into the oil; after this, repeat point 1.
3. Reinsert the drain plug.
4. Use a funnel to fill the gearbox slowly with oil through the breather screw opening (3) until the oil comes out of the oil level screw hole.
5. Screw in the oil level screw.

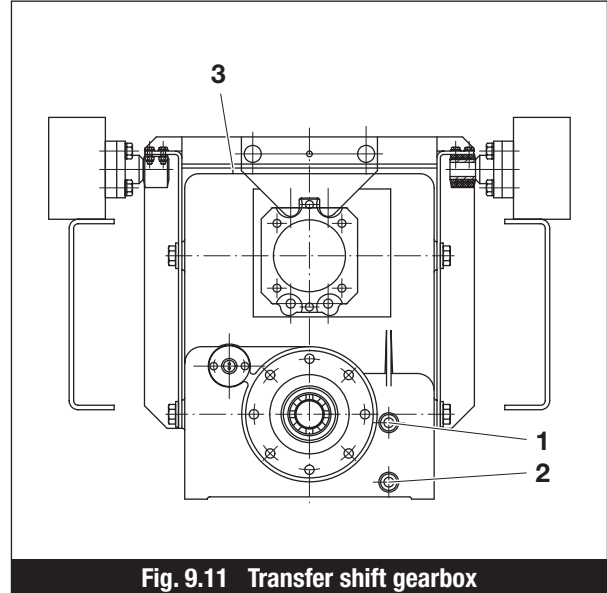

Fig. 9.11 Transfer shift gearbox

### 9.7.3 Changing the oil in the hydraulic system

Use oil grades / alternative grades as shown in the hydraulic oil reference table Fig. 9.4. Oil capacity 600 litres.



#### CAUTION:

Always refill with the same grade as was used previously. Before changing over to a biologically degradable oil the entire hydraulic system must be rendered totally oil-free. This procedure can only be performed by an authorised specialist company.

1. Remove the drain plug from the drain cock (Item 1, Fig. 9.12).
2. Connect a 1/2" hose from the drain cock to the container.

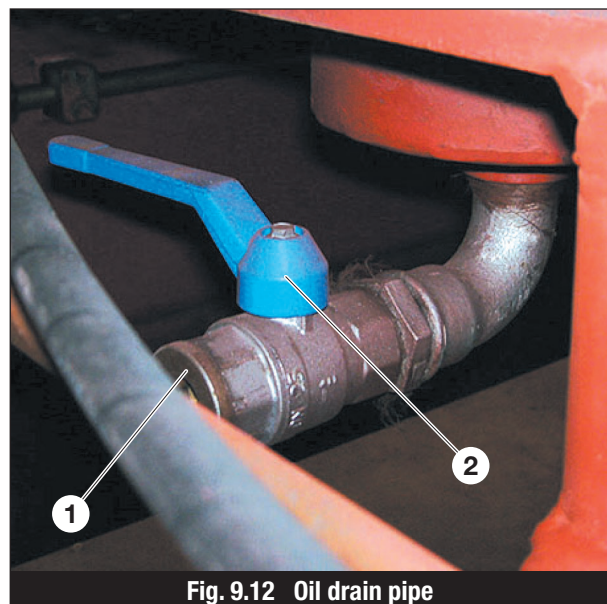

Fig. 9.12 Oil drain pipe



3. Open the filler neck cap (Item 3, Fig. 9.13).
4. Open the ball valve (Item 2, Fig. 9.12) and allow oil to drain into the container.
5. If the old oil is very dirty or has significant water content, flush the oil tank with suitable flushing oil.
6. Close the ball valve (Item 2, Fig. 9.12) and watch the oil emerging from the drain hole.
7. Pour hydraulic oil into the hydraulic tank through the return flow filter element, or pump it in using a pump with a fine filter.

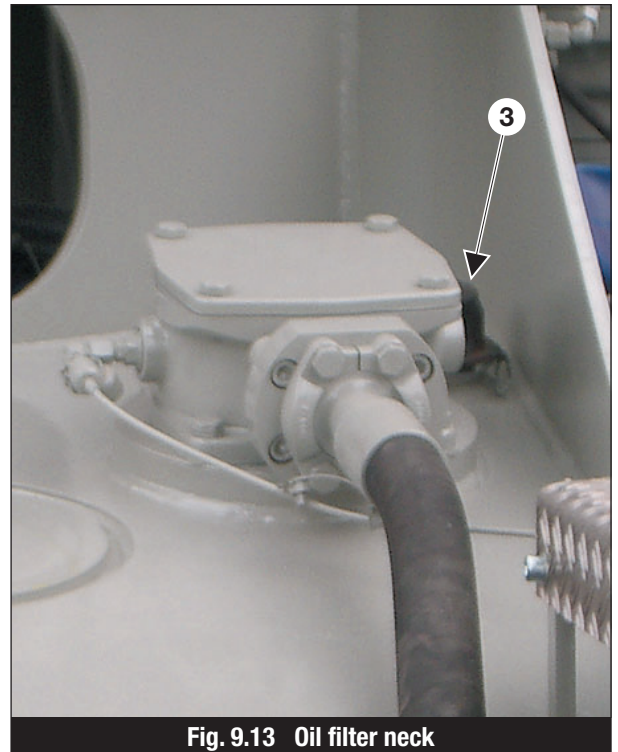

Fig. 9.13 Oil filter neck



### CAUTION:

**Never pour hydraulic oil into the tank directly from the barrel without filtration!**

8. Keep feeding hydraulic oil until the maximum oil level of 2 cm below the upper edge of the sight glass.
9. Close the filler neck cap (Item 3, Fig. 9.13) or the return flow filter.
10. Perform a trial run to check for leak-tightness.



### NOTE:

**Before operating the hydraulics, first run the system at idling for 15 minutes.**

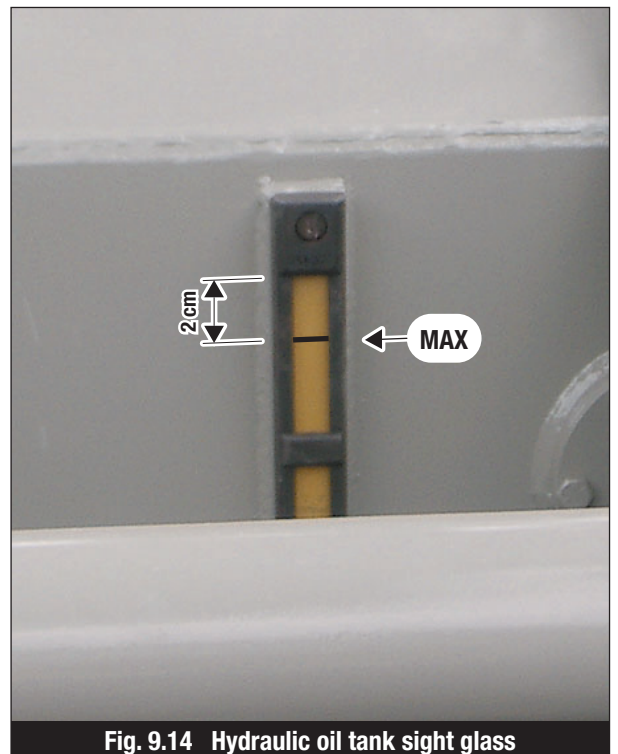

Fig. 9.14 Hydraulic oil tank sight glass



## 9.8 Performing tests

### 9.8.1 Measuring the wall thickness of the conveying pipework



#### **DANGER:**

- ☞ Only knock the conveying pipes apart and open them when they have been depressurised.
- ☞ Always pump backwards 1-2 piston strokes.

- Check the wear condition of the conveying pipework by knocking it, or better by using a wall thickness gauge. Replace worn parts.
- The wall thickness can also be measured using a special wall thickness gauge.

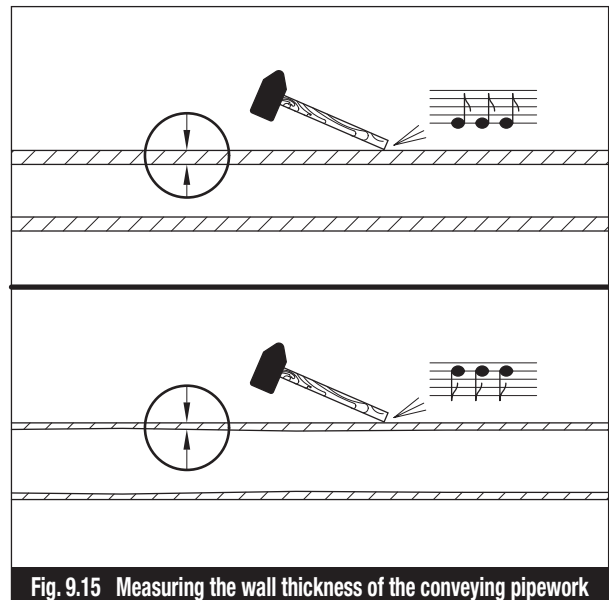



### 9.8.2 Minimum wall thicknesses and conveying pipework operating pressures

Always comply with the maximum pipe weight of the conveying pipework.

Unless stated otherwise on the serial plate:

Pipe 12.8 kg/m

Elbows

Y = Concrete pressure in bar

X = Minimum wall thickness in mm to DIN 2413 part 3

DN = Nominal diameter

Conveying pipework designation:      Standard size  
    Maximum pressure  
    Code

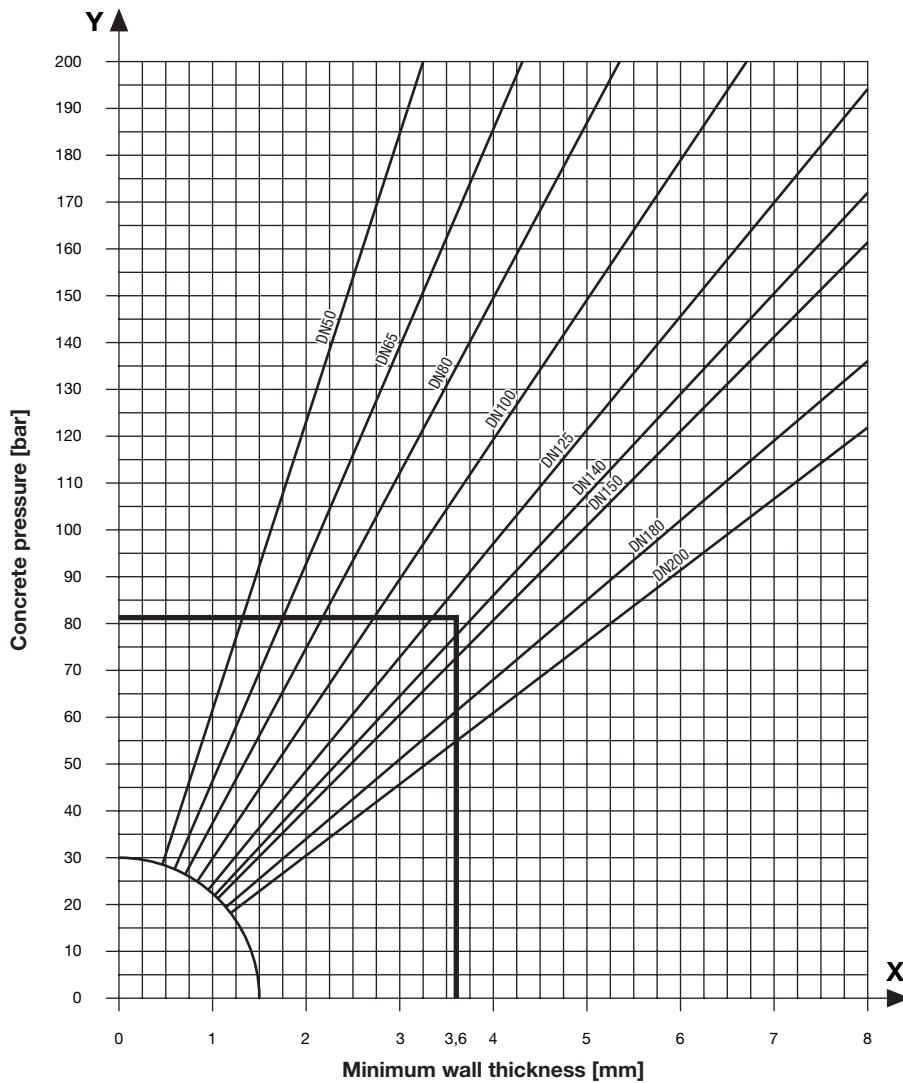

Fig. 9.16 Minimum wall thickness diagram



### 9.8.3 Adjusting the S-valve

Perform the following steps to adjust the S-valve:

1. Remove the locking plate (1) from the swing lever.
2. Tighten the screw (2) to approx. 100 Nm, then back off by 30%.
3. Refit the locking plate.
4. Perform a trial run of the concrete pump.

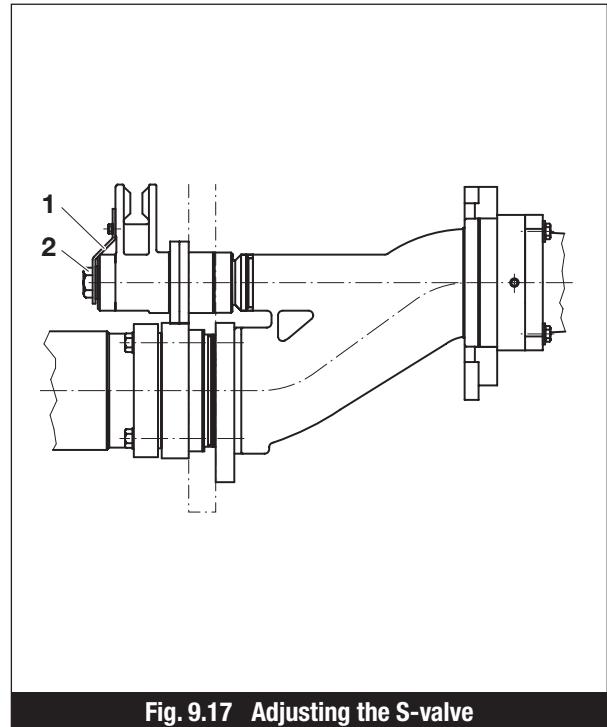

Fig. 9.17 Adjusting the S-valve

### 9.8.4 Checking the chain tension on the outrigger feet

When the chain tension is correctly set, the chain should sag no more than 30 mm. If the chain tension reduces, it must be tightened.

To do this, proceed as follows:

- Use the adjustment nut (1) to tighten the chain until the correct sag of 30 mm is achieved.

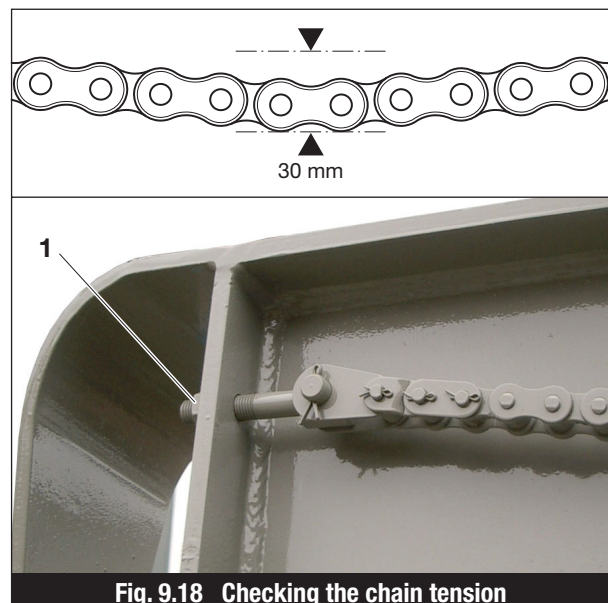

Fig. 9.18 Checking the chain tension





### 9.8.5 Checking the backlash in the slewing gearbox

The backlash is checked as follows:

1. Remove the pinion gear cover.
2. With the boom in the horizontal position, slew it slightly until a tooth is engaged without play.
3. Insert a feeler gauge to measure the engagement clearance as shown in the adjoining diagram.
4. If the backlash is excessive, the gearbox and the ball bearing slewing rim must be adjusted by a skilled fitter.

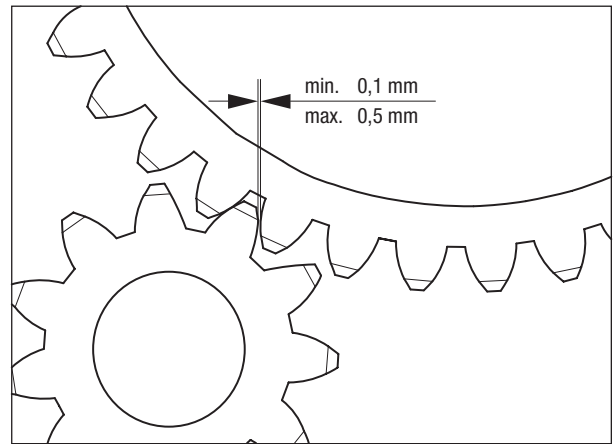

Fig. 9.19 Checking the backlash in the slewing gearbox

### 9.8.6 Checking the boom backlash (ball bearing slewing rim in the slewing gearbox)

Boom backlash means the increased play between outer ring and inner ring of the ball bearing slewing rim in the slewing gearbox.

- The calculation of boom backlash may only be performed by a specialist authorised workshop.
- The measurement must be performed at 2 points (loaded side and unloaded side) as shown in the diagram alongside.

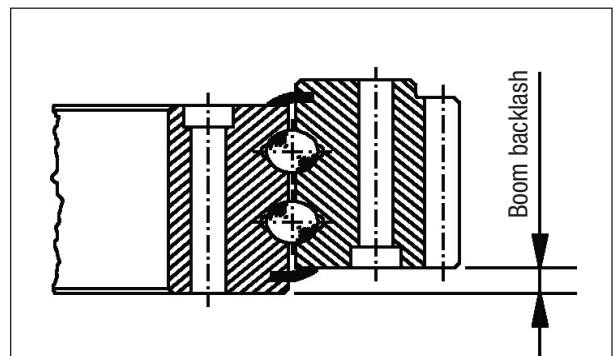

Fig. 9.20 Checking the boom backlash

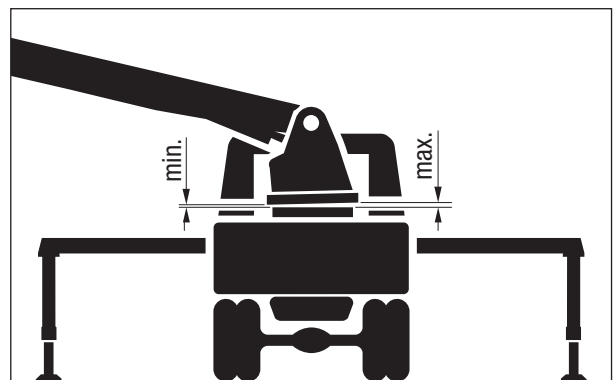

Fig. 9.21 Measurement points for checking the boom backlash



- The difference between the two values is the exact value for the measured backlash. This value must be entered in the boom test book every time the boom is tested. The maximum permissible value shown in the adjoining table must not be exceeded.

Rolling diameter [mm]	Ball diameter [mm]				
	20	22	25	30	40
1.000	1,8	1,9	1,9	2,0	2,5
1.250	1,9	2,0	2,0	2,1	2,6
1.500	2,0	2,1	2,1	2,2	2,7
1.750		2,2	2,2	2,3	2,8
2.000			2,3	2,4	2,9
2.250				2,5	3,0
2.500					3,1

Fig. 9.22 Maximum values for the boom backlash

### 9.8.7 Checking the operation of the sensors

The operation of the sensors is checked as follows:

There are two ways of checking the condition of the sensors.

- Directly in the sensor or in its plug there are one or two LEDs.

One LED      Green = Switch activated

Two LEDs    Green = Power on  
                  Yellow = Switch activated

- On the 4-fold distributor there are

Two green LEDs      Power for the sensors

Each with a yellow LED      Switch activated

Drive cylinder sensors:      Move the drive cylinder (1) to the end of its travel to check the operation of the sensor (2).

Oscillation cylinder sensors:      Move the oscillation cylinder (3) to the end of its travel to check the operation of the sensor (4).

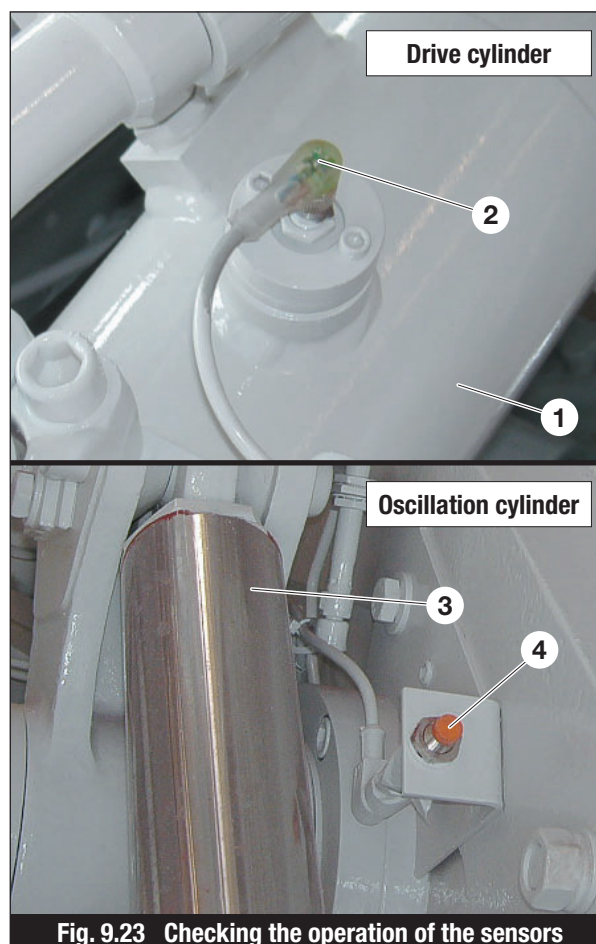

Fig. 9.23 Checking the operation of the sensors



## 9.9 Replacing worn parts

### 9.9.1 Exchanging the wear plate and wear ring



#### **DANGER:**

When working in the hopper and in the area of the oscillation cylinder, always switch the engine off and remove the ignition key.

1. Remove the locking plate (1) from the swing lever. Undo the screws (2 and 3) to relieve the load on the S-valve by 15 mm.
2. Exchange the free wear plate (4) by removing the first 2 screws (6) and tighten the screws.
3. Swing the S-valve over to the other side.
4. Remove the second wear plate by removing the other two screws (6).
5. Swing the S-valve back to the other side and exchange the wear ring (5).
6. Swing the S-valve on to the wear plate already fitted and fit the second wear plate.
7. Restore the S-valve pre-load by tightening the 4 screws (3).
8. Tighten the screw (2) by hand until the gap is closed. Back off the screw by at least 1/6 of a turn and refit the locking plate.

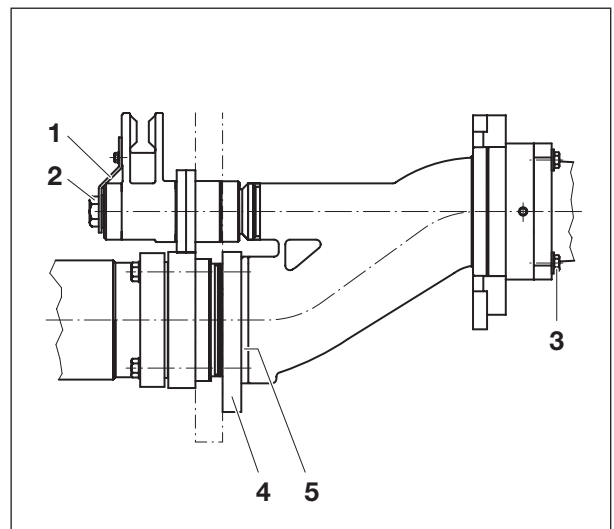

**Fig. 9.24 Changing the wear plate and wear ring 1**



#### **NOTE:**

Tighten the screws (3 and 4) to the torque set out in the table in section 9.3.

9. Perform a trial run.

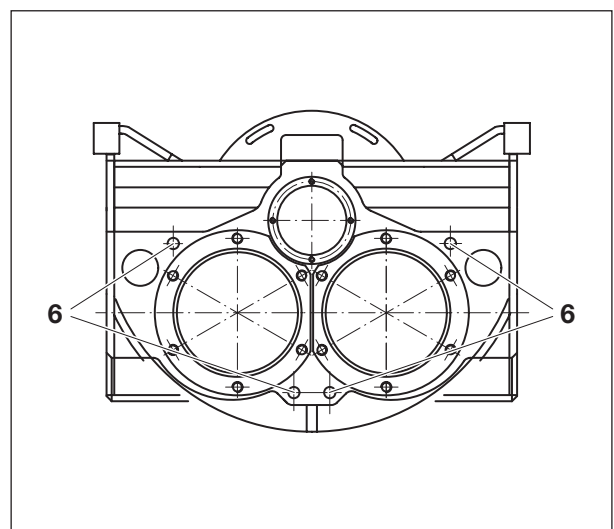

**Fig. 9.25 Changing the wear plate and wear ring 2**



### 9.9.2 Changing the conveying piston

- Turn a hardened conveying piston by 180° after 2 mm wear (4 mm on the diameter); turn a chromium plated conveying piston by 180° when the chromium plate layer is 30 µm.



#### DANGER:

- ☞ When working in the wash-out tank always switch off the engine and take out the ignition key.
- ☞ Never reach your hands into the wash-out tank when the engine is running.
- ☞ Always actuate the hydraulic cylinder by actually actuating the valves (see section 7.5.4.3) at a low engine speed and reduced stroke rate.

1. Drain the water tank and remove the protective grill.
2. Actuate valves Y3 and Y4 to move one drive cylinder to the end of its travel.
3. Remove hose clip (2) and snap coupling (4).

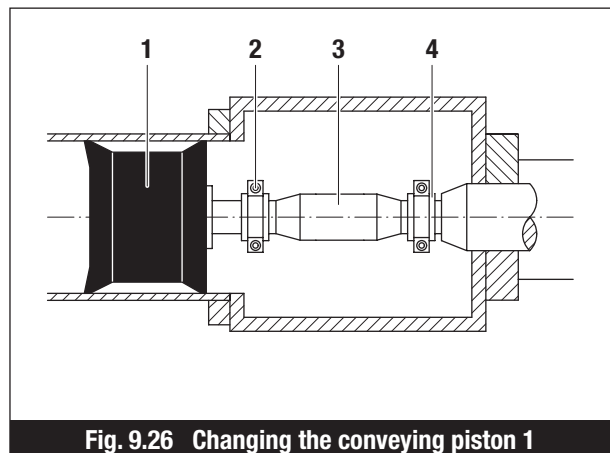

4. Push the conveying piston (1) about 5 mm towards the conveying cylinder by levering with a pry bar, and remove the spacer (3).

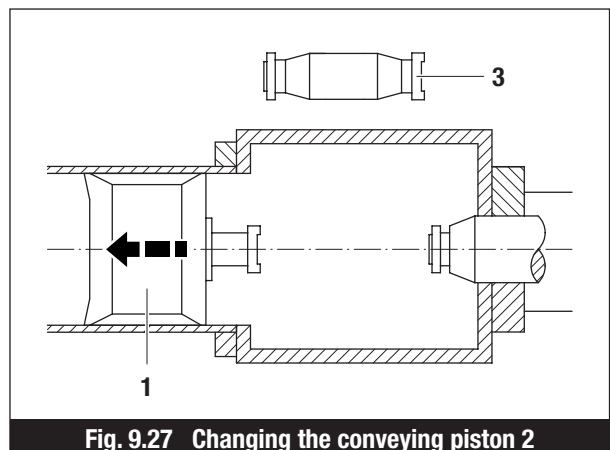



- Carefully move the drive cylinder out until it touches the flange. Fit a snap coupling (4).

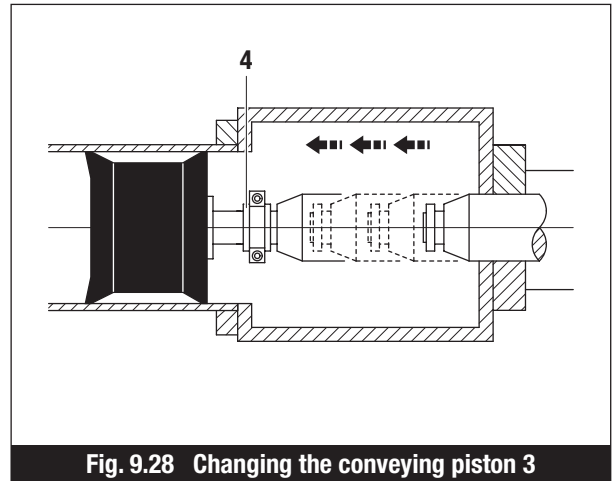

**Fig. 9.28 Changing the conveying piston 3**

- Move the drive cylinder back in, and remove the snap coupling (4) and the conveying piston (1).

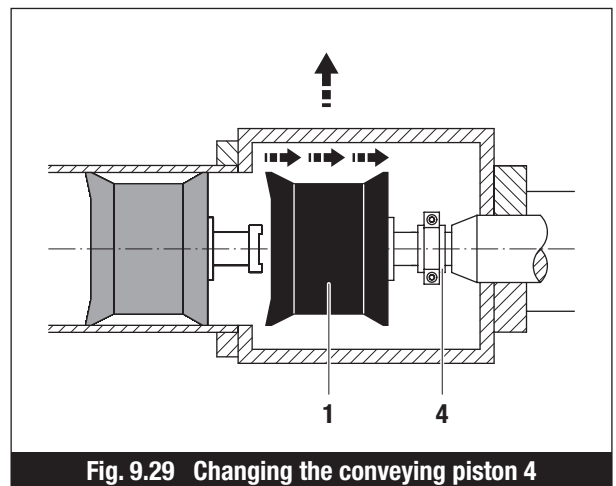

**Fig. 9.29 Changing the conveying piston 4**

- Liberalily lubricate the new conveying piston (1), attach a shell coupling (4) and fit it.

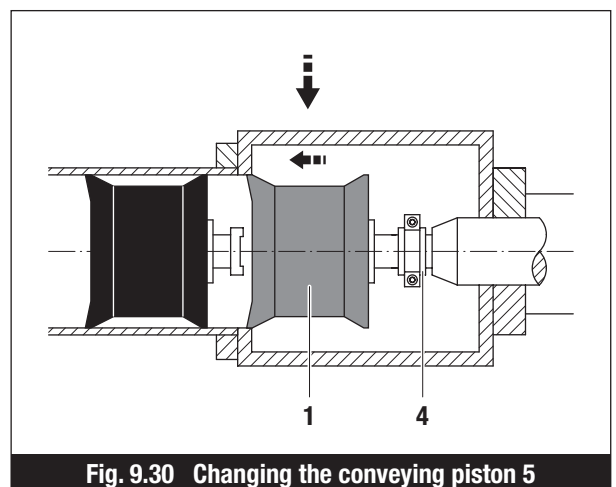

**Fig. 9.30 Changing the conveying piston 5**



8. Use the drive cylinder to move the conveying piston far enough for there to be room to fit the spacer (3).
9. Remove the snap coupling (4) and back off the drive cylinder to the end of its travel.
10. Fit the spacer (3) to the drive cylinder with the snap coupling (4).
11. Push the conveying piston (1) on to the spacer (3) by levering with a pry bar and fit the snap coupling (4).
12. Fit the hose clip (2).

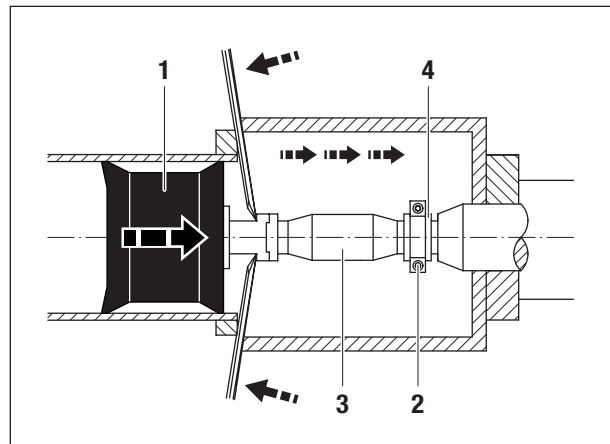

Fig. 9.31 Changing the conveying piston 6

### 9.9.3 Changing / turning the conveying cylinder

1. Remove the conveying cylinder as described in section 9.9.2.
2. Move both drive cylinders to the limit of their travel: Disconnect the oscillation pipe from a retracted drive cylinder and hang it over a container. Slowly move the drive cylinder to limit of its travel by actuating valves Y5 + Y6 manually.
3. Disconnect the shaft, support the wash-out tank.
4. Remove the 26 screws (1) and support the conveying cylinder, e.g. with a fork lift truck.
5. Lift the slide housing with a crane.

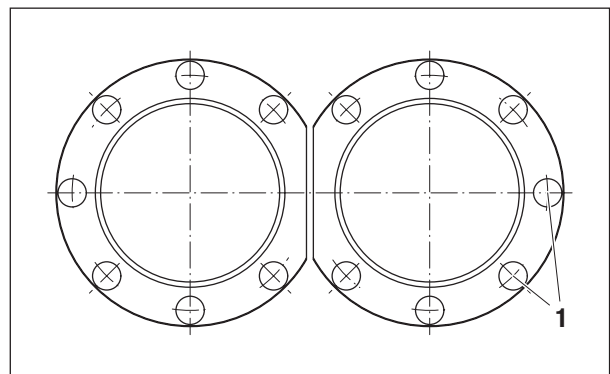

Fig. 9.32 Changing / turning the conveying cylinder



#### NOTE:

When lifting, take care that no hoses or cables are trapped!

6. Remove or turn the conveying cylinder.



### NOTE:

To increase the working life of the conveying cylinders, these can be turned by 180°. Be sure to turn the conveying cylinders at the right time. If the wear has already passed the point of no return, the conveying cylinders must be replaced.

7. Refit the conveying cylinders in the reverse sequence to removal.
8. Fit the conveying pistons and oscillation pipe as described in section 9.9.2.
9. Manually activate valves Y3 and Y4 or the rocker switch (Item 11, Fig. 5.2) to slowly extend the right hand drive cylinder.
10. Bleed air from the drive cylinder.
11. Perform a trial run.

### 9.9.4 Changing the agitator blades

1. Remove the screws (2).
2. Change the agitator blades (1). Check that the seating faces are clean. The right hand agitator blades must be 90° out of phase with the left hand blades.
3. Fit the screws (2) and tighten them to the torque set out in the table in section 9.3. Always replace these screws.

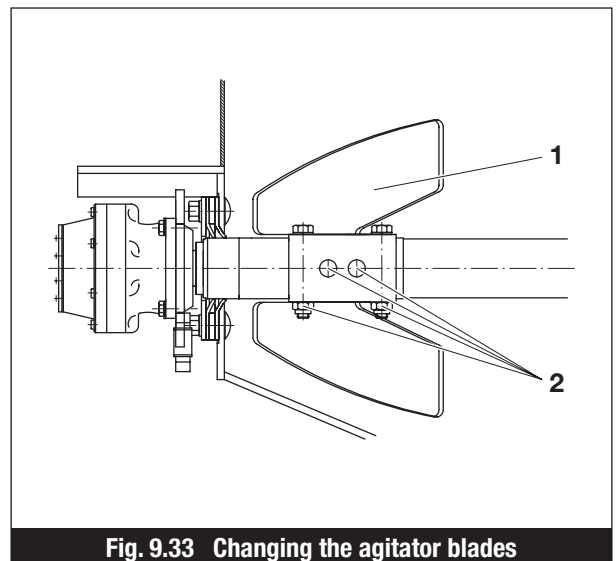

**Fig. 9.33 Changing the agitator blades**



### 9.9.5 Changing the agitator seals

1. Remove the agitator blades.
2. Pull the right hand motor (4) out approx. 10 mm and put the agitator shaft (3) to one side.
3. Remove the retaining ring (5), pull the left and right hand motors (4) out and put them to one side. Take care not to kink the hydraulic hoses.
4. Remove the screws (6) and take out the spacer plates with the seals (7).
5. Exchange the seals (7) and refit them. The gap between the seals must be completely filled with grease.
6. Reassemble the motors (4) and shafts (3) together with the agitator blades in the reverse sequence to removal (see Fig. 9.24).

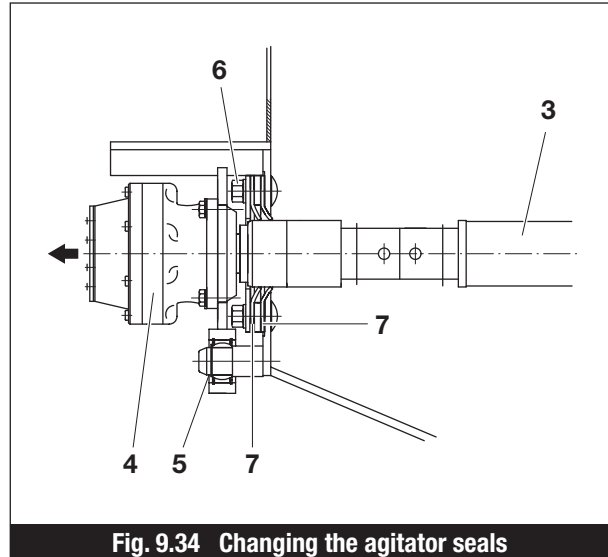

Fig. 9.34 Changing the agitator seals

### 9.9.6 Changing the agitator wear sleeves

1. Remove the motors (Item 4, Fig. 9.34) and put them in a safe place.
2. Knock the securing pin (8) fully inwards, remove the washer (9) and unscrew the nut (10).
3. Lever out the shaft (11) using pry bars.
4. Split the wear sleeves (12) off the shaft (11) and remove them.
5. Clean the shaft and evenly spread it with Loctite. Warm the new wear sleeves up to 200 °C and quickly slide them into place.
6. Refit the agitators in the reverse sequence to removal. A new hole must be drilled for the securing pin (8).

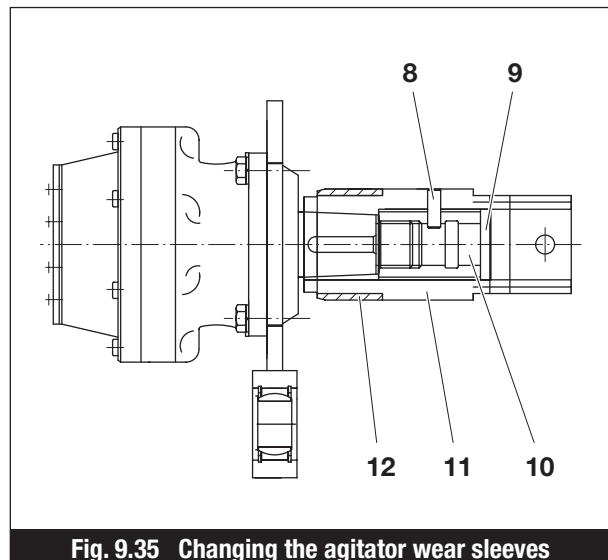

Fig. 9.35 Changing the agitator wear sleeves





### 9.10 Changing the conveying pipework

**CAUTION:**

The maximum weight of the conveying pipework and the conveying elbows on the boom, and the maximum pressure of 85 bar in the conveying pipework must be observed!

When the distributor boom is in the stowed position for transport it is not under stress; elements can thus easily be exchanged when it is in this configuration. If conveying pipes are replaced when the distributor boom is deployed, stresses may be introduced during assembly.

**CAUTION:**

A distance of 3 mm must be maintained between the flanges!

- Arrange the “Matching pipe lengths / Conveying pipes” as shown in the safety notice in Figure 2.16.

### 9.11 Crack-checking on the steelwork

**CAUTION:**

- ☞ Cracks on the distributor boom, on the boom mounting and the outriggers must be rectified immediately they are noticed! To do this, request the WAITZINGER repair guide without delay!
- ☞ Repairs must only be performed by an authorised specialist company!

- For crack checking the machine must be clean. Excess grease on the joints must be removed.
- Patches of rust and cracks in the paintwork can indicate underlying structural cracks.
- If there is doubt, have the steelwork checked by an authorised skilled operator using the “Dye penetrant crack detection method”.



### 9.12 Checking the hoses

**DANGER:**

If a hose splits suddenly under pressure, personnel can be seriously injured!

WAITZINGER takes no responsibility for damages that result from the use of worn or defective components.

Regular checking of hoses is part of the technical safety checks to be performed on the machine.

Do not repair damaged hydraulic or conveying pipes; instead replace them immediately. Damaged or weeping hydraulic hoses must also be replaced immediately.

All hydraulic hoses must be renewed after a life of 6 years (including a shelf life of 2 years), even if they exhibit no evident damage. The period of time can be calculated from the identification mark on the connection fitting (date of manufacture of the hose).

### 9.13 Cleaning the machine

- If the truck-mounted concrete pump is to be moved to another location for cleaning, move all parts of the machine to their transport positions.
- The truck-mounted concrete pump must not be driven with the distributor boom deployed or the outriggers extended, even for short distances.

**DANGER:**

☞ No highly flammable materials (e.g. petrol) may be used for cleaning!

☞ Never direct a water jet or steam jet towards electrical components, this can occasion a flashover with fatal consequences!



- Protect electrical components by covering them or sealing them shut to prevent ingress of water. After completion of cleaning, remove the covers and seals, leaving no residues.
- Never use seawater or other saline water for cleaning.
- Never use compressed air for cleaning.



- After completion of cleaning, check all pipework for leaktightness and loose connections, and check the machine for chafing points.
- Check all components for any sort of damage. If faults are found, rectify them immediately.
- If there is a risk of frost, completely drain the conveyor pipework, water tank and water pump. Leave all water drain points open.

## 9.14 Disposal of the machine



**NOTE:**

Observe national and regional legislative regulations and guidelines when disposing of the machine.





## 10. Repair work



### **WARNING:**

- ☞ Repair work must only be performed by trained personnel or service personnel who have been authorised by WAITZINGER!
- ☞ The user is not permitted to carry out repair work on his own account. Any work on the machine in breach of this provision will render the warranty void and relieve the manufacturer of all liability!



### **WARNING:**

- ☞ Only skilled specialists or trained personnel may perform repair work on electrical systems!
- ☞ Before carrying out electrical repair work the system must be electrically de-energised and this state must be secured for the duration of the work!  
The VDE regulations and the VBG 4 regulations must be complied with!
- ☞ When fitting fuses, fit only fuses of the same type and rating as were originally fitted!
- ☞ It is absolutely prohibited to repair fuses!







## 11. List of operators of the equipment

- Each operator of the equipment confirms here by his signature that he has received, read and understood this user manual.
- He agrees to comply with all instructions conscientiously.
- If he does not do so, the manufacturer's warranty will become void.

Operator name	Accepted on	Operator signature



# LIST OF OPERATORS OF THE EQUIPMENT

## CHAPTER 11



Make further copies if required

Operator name	Accepted on	Operator signature





## 12. Maintenance and modifications list

- Each operator should enter here in a clear manner all maintenance and modification work performed and present the list to the supervisor for confirmatory signature.
- This maintenance and modifications list should be made available on request to the “Employers’ Liability Insurance Association” or the “TÜV” properly filled in and signed.

Maintenance on	Modification on	Date	Operator signature	Confirmed by person responsible



# ***MAINTENANCE AND MODIFICATIONS LIST***

## ***CHAPTER 12***

---



Make further copies if required

<b>Maintenance on</b>	<b>Modification on</b>	<b>Date</b>	<b>Operator signature</b>	<b>Confirmed by person responsible</b>



# MAINTENANCE AND MODIFICATIONS LIST

## CHAPTER 12



Make further copies if required

Maintenance on	Modification on	Date	Operator signature	Confirmed by person responsible