

REED TRUCK MOUNTED CONCRETE BOOM PUMP MODEL XT 36 ILLUSTRATED PARTS MANUAL CONTAINS THE FOLLOWING GROUPS AND FIGURES:

GROUP 00 HOW TO USE PARTS MANUAL

- FIGURE 00** TABLE OF CONTENTS
- FIGURE 01** HOW TO USE PARTS MANUAL
- FIGURE 02** HOW TO ORDER PARTS

GROUP 10 FINAL INSTALLATION

- FIGURE 00** TABLE OF CONTENTS
- FIGURE 01** FINAL INSTALLATION
- FIGURE 02** DECAL ASSEMBLY

GROUP 20 HOPPER INSTALLATION

- FIGURE 00** TABLE OF CONTENTS
- FIGURE 01** HOPPER INSTALLATION
- FIGURE 02** LUBRICATION PUMP ASSEMBLY
- FIGURE 03** CENTRAL LUBRICATION SYSTEM
- FIGURE 04** HOPPER VIBRATION ASSEMBLY
- FIGURE 05** AGITATOR ASSEMBLY
- FIGURE 06** AGITATOR DRIVE MOTOR ASSEMBLY
- FIGURE 07** HOPPER OUTLET ASSEMBLY



**MODEL XT 36 TRUCK MOUNTED
CONCRETE BOOM PUMP
ILLUSTRATED PARTS MANUAL**

**XT 36
PARTS**
GROUP 00
FIGURE 00
PAGE 02

GROUP 30 TANK INSTALLATION

FIGURE 00	TABLE OF CONTENTS
FIGURE 01	TANK INSTALLATION
FIGURE 02	WATER SYSTEM GROUP
FIGURE 03	WASH WATER PUMP ASSEMBLY
FIGURE 04	WATER PUMP MOTOR ASSEMBLY
FIGURE 05	HYDRAULIC TANK ASSEMBLY
FIGURE 06	OIL COOLER MANIFOLD ASSEMBLY

GROUP 40 POWER TRAIN INSTALLATION

FIGURE 00	TABLE OF CONTENTS
FIGURE 01	POWER TRAIN INSTALLATION
FIGURE 02	GEAR PUMP ASSEMBLY
FIGURE 03	PTO GEARBOX ASSEMBLY

GROUP 50 CONTROLS INSTALLATION

FIGURE 00	TABLE OF CONTENTS
FIGURE 01	CONTROLS INSTALLATION
FIGURE 02	CAB CONTROLS ASSEMBLY
FIGURE 03	MAIN CONTROLS ASSEMBLY
FIGURE 04	LH SIDE OUTRIGGER CONTROLS ASSEMBLY
FIGURE 05	RH SIDE OUTRIGGER CONTROLS ASSEMBLY
FIGURE 06	STATIONARY BOOM CONTROLS ASSEMBLY
FIGURE 07	CABLED REMOTE CONTROL ASSEMBLY
FIGURE 08	RADIO REMOTE CONTROL ASSEMBLY
FIGURE 09	SHUNT ASSEMBLY

GROUP 60 PUMPING TRAIN INSTALLATION

FIGURE 00	TABLE OF CONTENTS
FIGURE 01	PUMPING TRAIN INSTALLATION
FIGURE 02	SWING VALVE ASSEMBLY
FIGURE 03	TILTING DRIVE ASSEMBLY
FIGURE 04	TILTING CYLINDER ASSEMBLY
FIGURE 05	CONCRETE CYLINDER ASSEMBLY
FIGURE 06	WATER BOX ASSEMBLY
FIGURE 07	HYDRAULIC DRIVE CYLINDER ASSEMBLY
FIGURE 08	DRIVE CYLINDER SUB-ASSEMBLY

GROUP 70 FRAME AND SUPPORT INSTALLATION

FIGURE 00	TABLE OF CONTENTS
FIGURE 01	FRAME AND SUPPORT INSTALLATION
FIGURE 02	TURRET ASSEMBLY
FIGURE 03	MOTOR AND REDUCTION ASSEMBLY
FIGURE 04	ROTATION UNIT ASSEMBLY
FIGURE 05	PEDESTAL ASSEMBLY
FIGURE 06	FRONT OUTRIGGER GROUP ASSEMBLY
FIGURE 07	REAR OUTRIGGER GROUP ASSEMBLY
FIGURE 08	OUTRIGGER EXTEND CYLINDER ASSEMBLY
FIGURE 09	OUTRIGGER JACK CYLINDER ASSEMBLY
FIGURE 10	SWING OUT CYLINDER ASSEMBLY
FIGURE 11	RIGHT HAND SIDE HOSE REEL ASSEMBLY
FIGURE 12	OUTRIGGER HOLDING VALVE ASSEMBLY

GROUP 80 OPTIONAL INSTALLATION

FIGURE 00	TABLE OF CONTENTS
FIGURE 01	OPTIONAL INSTALLATION
FIGURE 02	ACCUMULATOR CHARGE KIT
FIGURE 03	OPTIONAL TOO KIT ASSEMBLY

GROUP 90 BOOM INSTALLATION

FIGURE 00	TABLE OF CONTENTS
FIGURE 01	BOOM INSTALLATION
FIGURE 02	BOOM SECTION "A" ASSEMBLY
FIGURE 03	BOOM CYLINDER "1" ASSEMBLY
FIGURE 04	BOOM CYLINDER "2" ASSEMBLY
FIGURE 05	BOOM SECTION "B" ASSEMBLY
FIGURE 06	BOOM CYLINDER "3" ASSEMBLY
FIGURE 07	BOOM SECTION "C" ASSEMBLY
FIGURE 08	BOOM CYLINDER "4" ASSEMBLY
FIGURE 09	BOOM SECTION "D" ASSEMBLY
FIGURE 10	BOOM DELIVERY LINE ASSEMBLY
FIGURE 11	DECK DELIVERY LINE ASSEMBLY

I. PURPOSE

This parts manual is prepared, issued and/or revised by **REED** Manufacturing, for the exclusive use of its customers and is intended for use in provisioning, requisitioning, storing and issuing replaceable **REED** truck mounted concrete boom pump model **XT 36**. The contents are proprietary to **REED** and are subject to change without notice. The use of any part of this document by any other person or persons or for any other purpose without the written consent of **REED** is expressly prohibited. In addition, **REED** expressly disclaims any and all responsibility arising in or any way related to such **REED'S** prior written consent thereto.

The parts number content of this document, arrangement and breakdown sequence of items is compatible with Military Standard (**MS**) and Air Transport Association Specification (**ATA**).

II. GENERAL SYSTEM OF ASSEMBLY ORDER - Detailed Parts List (Refer to Next Page)

1. This area refers to the corresponding illustration

MODEL - GROUP - FIGURE - PAGE

A. **MODEL** shows which is **REED'S** model number.

B. **GROUP** should be divided with:

00	MODEL XT 36 ILLUSTRATED PARTS MANUAL
10	FINAL INSTALLATION
20	HOPPER INSTALLATION
30	TANK INSTALLATION
40	POWER TRAIN INSTALLATION
50	CONTROL INSTALLATION
60	PUMPING TRAIN INSTALLATION
70	FRAME AND SUPPORT INSTALLATION
80	OPTIONAL INSTALLATION
90	BOOM INSTALLATION

C. **FIGURE** belong to the group. Please see page of contents and each group.

D. **PAGE** numbers follow to the right of each figure number.

2. The **ITEM NUMBER** corresponds to the item number shown for the part in illustration. Parts with item number preceded by a dash (such as: -1, -5, -12 etc.) are not illustrated.

3. **PARTS NUMBERS** that carry a **REED** part number.



HYDRAULIC PUMPING ASSEMBLY

XT 36
PARTS
GROUP 60
FIGURE 06
PAGE 02

ITEM NO.	REED'S PARTS NO.	DESCRIPTION					QTY
		1	2	3	4	5	
-1	60-06	Assembly, Hydraulic Pumping (See Group 20, Figure 01 for NHA)					Ref
2	78354	• Cup, Piston					2
3	78444	• Coupler					2
4	78352	• Coupling, Dog bone					4
5		• Bolt 1/2 x 4 (attaching parts)					8
6		• Nut, 1/2 (attaching parts)					8
7	78443	• Bone, Dog					2
8		• Bolt 5/8 x 2					6
9	78442	• Coupler					2
10	78438	• Assembly, Hydraulic Cylinder (See Group 60, Figure 07 for DET)					1
11		• Nut (attaching parts)					16
12		• Washer (attaching parts)					16
13	77617	• Bolt (attaching parts)					16
14		• Elbow, 90 FS6802-16-16					4
15	79343	• Assembly, Hose					2
16	78593	• Fitting, MiniCheck (Port)					2
17		• Elbow, 90 FS6802-06-06					4
18		• Fitting, STR FS6400-06-06					4
19	79344	• Assembly, Hose					2
20		• Elbow, 90 FS6801-06-06					4
21		• Valve, Check					4
22		• Elbow, 90 MBMB90-06-06					4
23		• Clamp					3
24	79326	• Tube, Wire					1
25	79345	• Assembly, Tube					2
26	78417	• Cable					2
27	72010	• Loom, 1/2 Flex					A/R
28		• Pin, 1/4 x 20					4
29	79285	• Cover, Proximity Switch					2
30	78416	• Switch, Proximity					2
31	79327	• Plate, End					1
32		• Washer, 1 Lock (attaching parts)					8
33		• Bolt, 1 x 2 Course (attaching parts)					8

DASH (-) ITEM NOT ILLUSTRATED

REVISION:

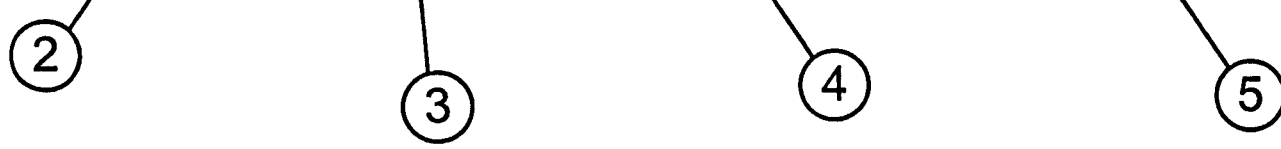



REED
CONCRETE PLACING
EQUIPMENT

HYDRAULIC PUMPING ASSEMBLY

XT 36
PARTS
GROUP 60
FIGURE 06
PAGE 02

ITEM NO.	REED'S PARTS NO.	DESCRIPTION					QTY
		1	2	3	4	5	
-1	60-06	Assembly, Hydraulic Pumping (See Group 20, Figure 01 for NHA)					Ref
2	78354	• Cup, Piston					2
3	78444	• Coupler					2
4	78352	• Coupling, Dog bone					4
5		• Bolt 1/2 x 4 (attaching parts)					8
6		• Nut, 1/2 (attaching parts)					8
7	78443	• Bone, Dog					2
8		• Bolt 5/8 x 2					6
9	78442	• Coupler					2
10	78438	• Assembly, Hydraulic Cylinder (See Group 60, Figure 07 for DET)					1
11		• Nut (attaching parts)					16
12		• Washer (attaching parts)					16
13	77617	• Bolt (attaching parts)					16
14		• Elbow, 90 FS6802-16-16					4
15	79343	• Assembly, Hose					2
16	78593	• Fitting, MiniCheck (Port)					2
17		• Elbow, 90 FS6802-06-06					4
18		• Fitting, STR FS6400-06-06					4
19	79344	• Assembly, Hose					2
20		• Elbow, 90 FS6801-06-06					4
21		• Valve, Check					4
22		• Elbow, 90 MBMB90-06-06					4
23		• Clamp					3
24	79326	• Tube, Wire					1
25	79345	• Assembly, Tube					2
26	78417	• Cable					2
27	72010	• Loom, 1/2 Flex					A/R
28		• Pin, 1/4 x 20					4
29	79285	• Cover, Proximity Switch					2
30	78416	• Switch, Proximity					2
31	79327	• Plate, End					1
32		• Washer, 1 Lock (attaching parts)					8
33		• Bolt, 1 x 2 Course (attaching parts)					8

DASH (-) ITEM NOT ILLUSTRATED

REVISION:



4. DESCRIPTION

- A. The **INDENTURE SYSTEM** used in the parts list shows the relationship of one part to another. For a given item, the number of indentures depicts the relationship of the item to the components of the item as follows:

1 2 3 4 5

Assembly (or Installation)

- Detail part of assembly
 - Sub-assembly
 - Attaching parts for sub-assembly
 - ● Detail part of sub-assembly
 - ● Sub-sub-assembly
 - ● Attaching parts for sub-sub-assembly
 - ● ● Detail part of sub-sub-assembly
 - ● ● Sub-sub-sub-assembly
 - ● ● Attaching parts of sub-sub-sub-assembly
 - ● ● ● Detail part of sub-sub-sub-assembly
- B. "See Group 20, Figure 01 For **NHA**"
Identifies the illustrated parts chapter location; indicates where the Next Higher Assembly (**NHA**) of the item shown.
- C. "See Group 60, Figure 07 For **DET**"
Identifies the illustrated parts chapter location; indicates where the item and its Detailed Breakdown (**DET**) is shown.
- D. "See Group 30, Figure 05 for **REF**" or "See Vendor Chapter For **REF**"
Identifies the illustrated parts chapter where the part is, and if listed and illustrated in Vendor Chapter. It is used as a cross-reference (**REF**).

5. QUANTITY

- A. Reference (**REF**) indicates the items that is listed previously in the Next Higher Assembly (**NHA**) and then again in this figure.
- B. As Required (**A/R**) indicates the parts that is used in a quantity as required.
- C. A number entry indicates the quantity of the part used in its next higher application.
6. Functionally related assemblies are illustrated in phantom (_____) but not listed on the detail parts list page.

1. Always give serial number and model of **REED** truck mounted concrete boom pump model: **XT 36**. (Refer to each unit name plate shown below). NOTE: This manual is being released to cover unit starting with serial number **01 - 211 - XT 36** to current production. Some components used on earlier units differ from current productions. Where this occurs, the part is identified by a serial number.

REED		PHONE (909) 364-2100		CE
13822 OAKS AVENUE		FAX (909) 364-2140		
CHINO, CA 90710 USA				
MODEL	_____	SERIAL NO.	_____	
HYD. PRESSURE	_____	PSI	_____	BAR
ELECTRIC MOTOR/ ENGINE SPEED	_____	RPM	_____	VOLTS
VEHICLE WEIGHT (APPROX.)	_____	LBS	_____	KG

75009A

2. Always specify part number and complete name of parts ordered.
- A. Turn to table of content in the desired Installation.
Refer to main group in which part should be listed.

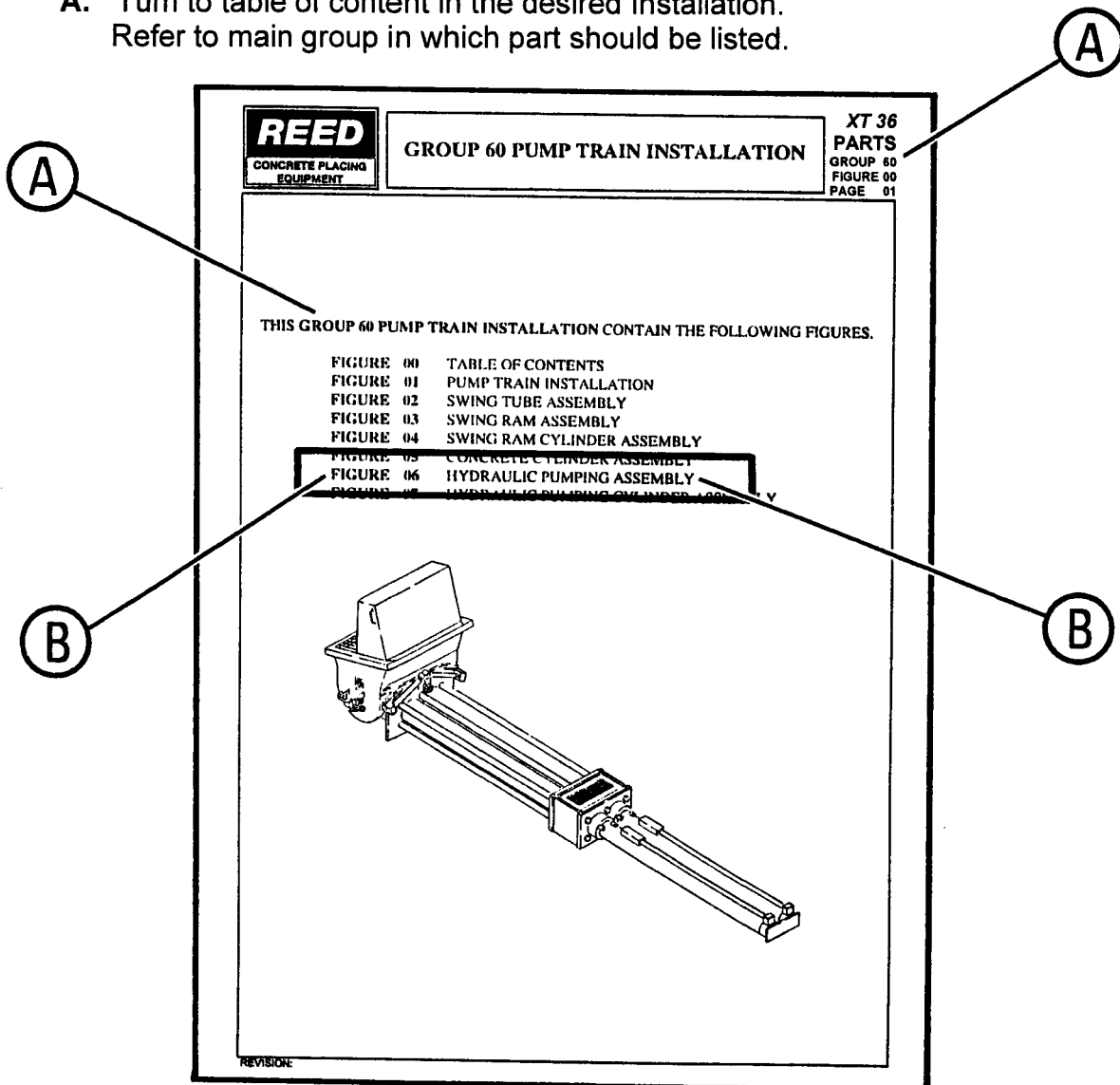

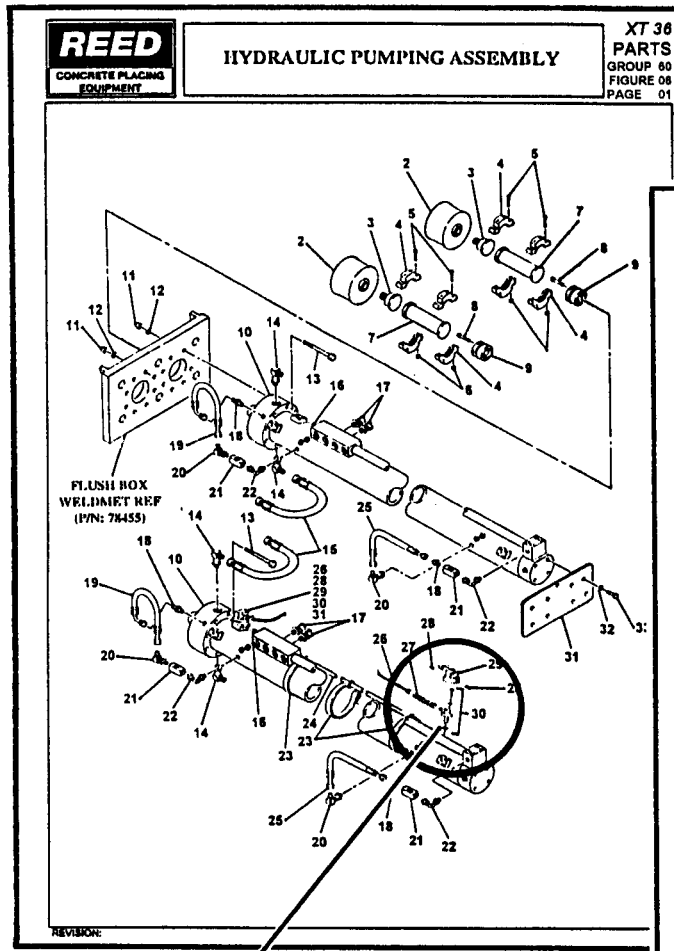

ITEM NO.	REED'S PARTS NO.	DESCRIPTION	QTY
1	60-06	Assembly, Hydraulic Pumping (See Group 20, Figure 1 for NHA)	Ref
2	78154	* Cup, Piston	2
3	78444	* Coupler	2
4	78152	* Coupling, Dog	4
5		* Bolt 1/2 x 4 (attaching parts)	8
6		* Nut, 1/2 (attaching parts)	8
7	78441	* Bone, Dog	2
8		* Bolt 5/8 x 2	6
9	78442	* Coupler	2
10	78438	* Assembly, Hydraulic Cylinder (See Group 60, Figure 07 for DET)	1
11		* Nut (attaching parts)	16
12		* Washer (attaching parts)	16
13	77617	* Bolt (attaching parts)	16
14		* Elbow, 90 F56802-06-16	4
15	79143	* Assembly, Hose	2
16	78593	* Fitting, Minicheck (Port)	2
17		* Elbow, 90 F56802-06-06	4
18		* Fitting, STD F56801-06-06	4
19	79144	* Assembly, Hose	2
20		* Elbow, 90 F56801-06-06	4
21		* Valve, Check	4
22		* Elbow, 90 M18M1091-06-06	4
23		* Clamp	3
24	79126	* Tube, Wire	1
25	79345	* Assembly, Tube	2
26	78417	* Cable	2
27	72010	* Loxon, 1/2 Flex	A/R
28		* Pin, 1/4 x 20	4
29	79285	* Switch, Proximity	2
30	78416	* Switch, Proximity	2
31	78455	* Flush Box Weldment	1
32		* Washer, 1 Lock (attaching parts)	8
33		* Bolt, 1 x 2 Course (attaching parts)	8

- B. Find title of figure in which the part should be shown. Note figure number.
- C. Turn to corresponding page, find the group and figure.
- D. Check your required part and its attaching parts and match with illustration page.
- E. Refer to corresponding item number in the part list page. Part numbers are located in the part number column.
- F. When ordering variable or optional miscellaneous parts which are not found this in parts chapter, follow the above outlined procedure of how to order parts.
 - 1). When applicable, give model and serial number of the component for which parts are desired.
 - 2). In a specific, difficult to describe situation, a marked-up photograph or detailed sketch would be helpful.

3. Do not designate quantity by "set". State specifically how many parts are wanted.
4. Always give complete address and full shipping instructions. Specify shipping instructions, truck freight, air freight. United Parcel Service (UPS), or Air Borne Express and DHL are available in designated areas.

5. TO ORDER**A. BY MAIL**

Attention: Parts Department
REED
13822 Oaks Avenue
Chino, CA. 91710 - 7008

B. BY FAX

(909) 287 - 2141

C. BY PHONE

(909) 287 - 2100

6. Parts return without authorization will not be accepted. If it is necessary to return parts for any reason, written authorization may be obtained from **REED** Parts Department, Chino, CA. 91710-7008. A Parts Return Authorization form is provided when **REED** deems its necessary to have the part returned for evaluation. The form is issued by the Warranty of Parts Department of **REED**.
 - A. The form will be filled by **REED** unless requesting necessary information and you will receive a copy as well as shipping tag.
 - B. Attach shipping tag to part insert return original invoice.
 - C. Ship part to **REED PREPAID**.
 - D. Part must be returned to **REED** within 30 days from date of authorization.

REED TRUCK MOUNTED CONCRETE BOOM PUMP MODEL XT 36 ILLUSTRATED PARTS MANUAL GROUP 10 FINAL INSTALLATION CONTAINS THE FOLLOWING FIGURES:

- FIGURE 00** TABLE OF CONTENTS
- FIGURE 01** FINAL INSTALLATION
- FIGURE 02** DECAL ASSEMBLY

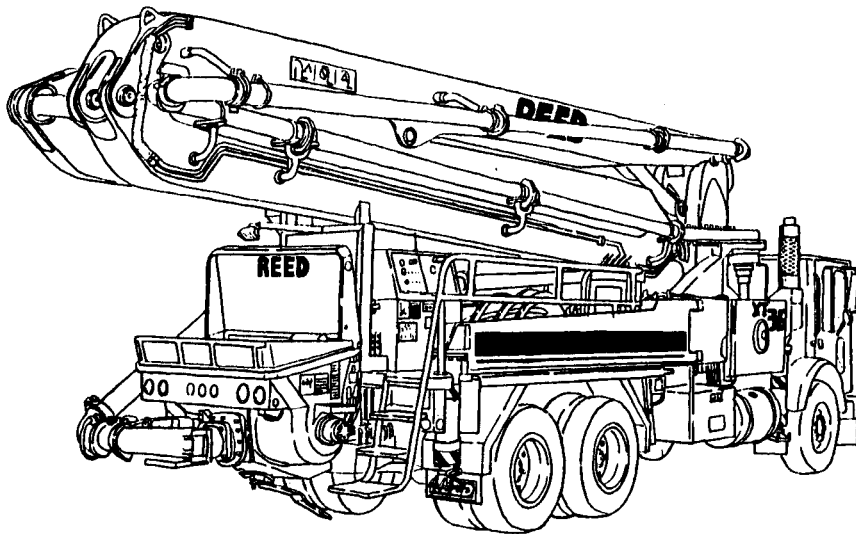

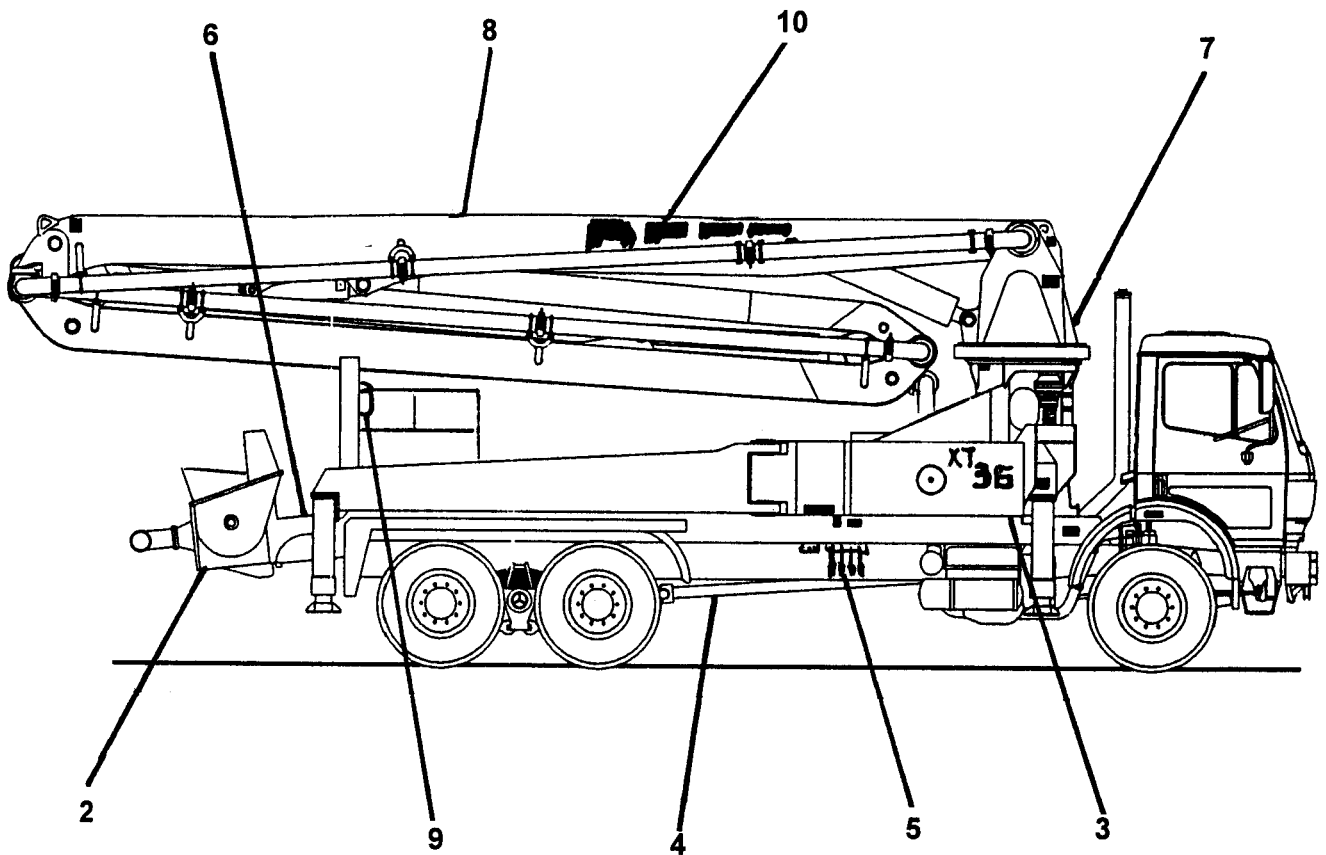



XT 36 FINAL INSTALLATION

XT 36
PARTS
GROUP 10
FIGURE 01
PAGE 02

ITEM NO.	REED'S PARTS NO.	DESCRIPTION	QTY
-1	XT 36 - V03	Installation, XT 36 Final	Ref
2	20-01	• Installation, Hopper (See Group 20, Figure 01 for DET)	1
3	30-01	• Installation, Tank (See Group 30, Figure 01 for DET)	1
4	40-01	• Installation, Power Train (See Group 40, Figure 01 for DET)	1
5	50-01	• Installation, Control (See Group 50, Figure 01 for DET)	1
6	60-01	• Installation, Pumping Train (See Group 60, Figure 01 for DET)	1
7	70-01	• Installation, Frame and Support (See Group 70, Figure 01 for DET)	1
8	80-01	• Installation, Optional (See Group 80, Figure 01 for DET)	1
9	802431	• Installation, Boom (See Group 90, Figure 01 for DET)	1
10	10-02	• Assembly, Decal (See Group 10, Figure 02 for DET)	1

DASH (-) ITEM NOT ILLUSTRATED

REED

DECAL ASSEMBLY

XT 36
PARTS
GROUP 10
FIGURE 02
PAGE 01

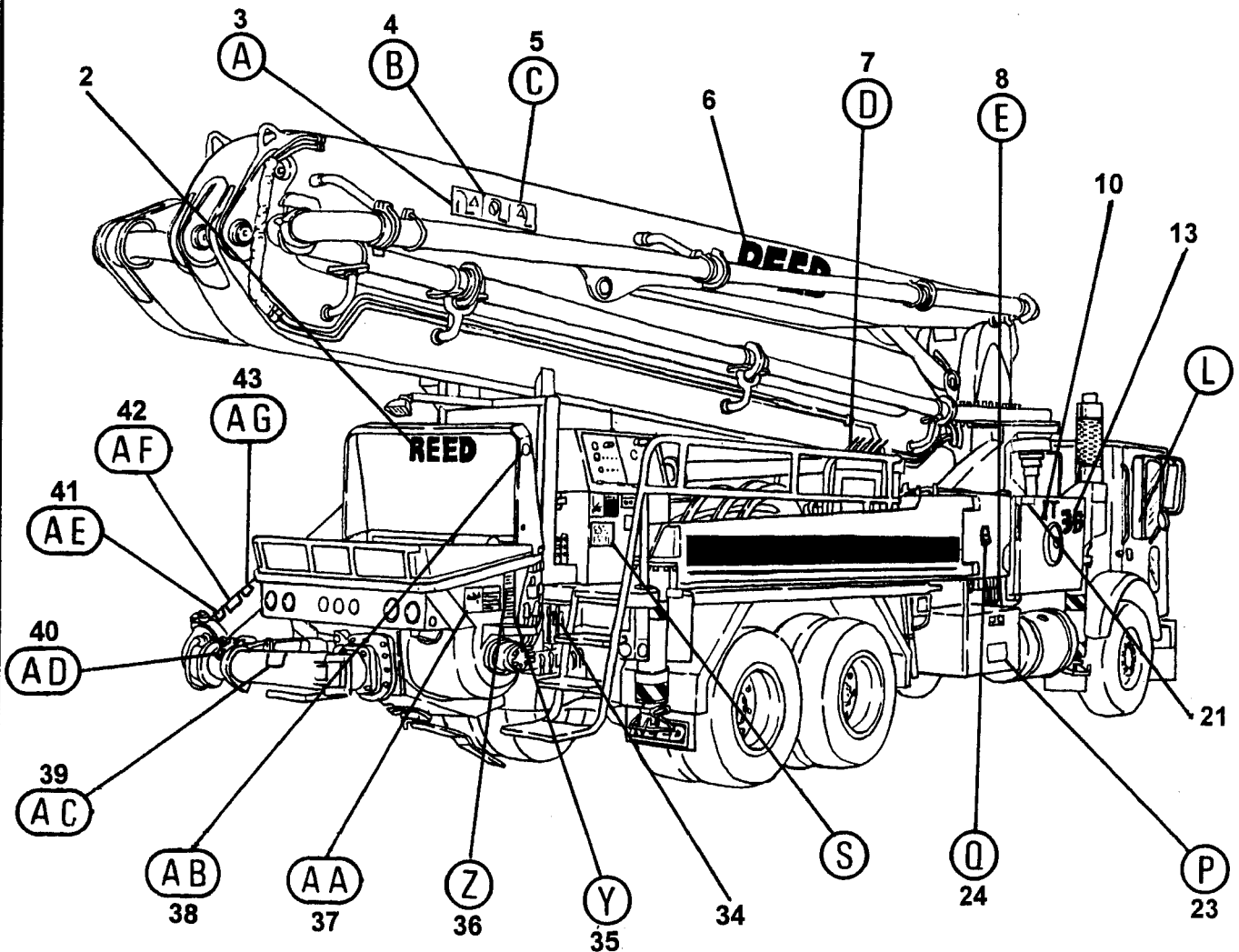
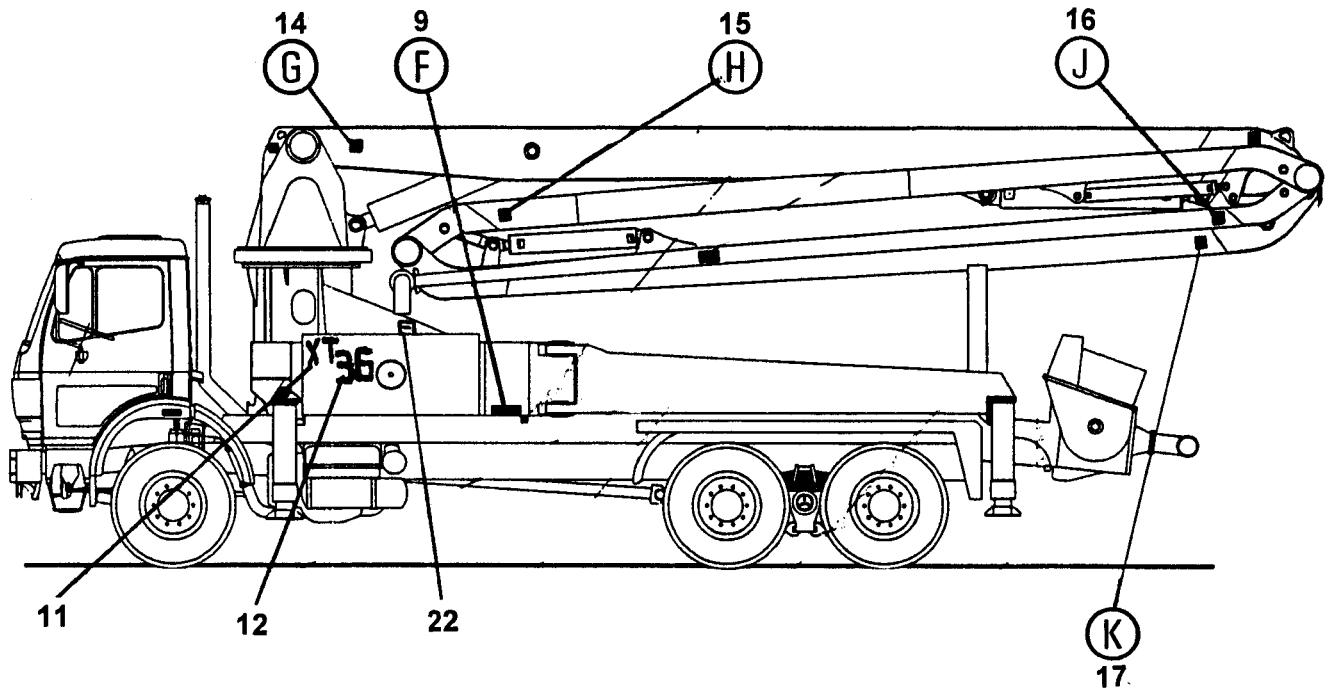

REVISION:



DECAL ASSEMBLY

XT 36
PARTS
 GROUP 10
 FIGURE 02
 PAGE 02

ITEM NO.	REED'S PARTS NO.	DESCRIPTION	QTY
-1	10-02	Assembly, Decal (See Group 10, Figure 01 for NHA)	Ref
2	800442	• Decal, REED , 6 Inch Black	1
3	C-4V107	• Plate, Danger Of Falling Object	1
4	C-4V106	• Plate, Never Use As Crane	1
5	C-4V105	• Plate, Death Hazard	1
6	801069	• Decal, REED , 12 Inch White	2
7	802272	• Nameplate, Boom Valve	1
8	802271	• Nameplate, XT 36 Right Side Outrigger	1
9	802270	• Nameplate, XT 36 Left Side Outrigger	1
10	801066	• Decal, XT , 4 Inch White	1
	801246	• Decal, XT , 4 Inch Black	1
11	801067	• Decal, XT , 5 Inch White	1
	801246	• Decal, XT , 4 Inch Black	1
12	801071	• Decal, 36 , 8 Inch White	1
	801248	• Decal, 36 , 7 Inch Black	1
13	801072	• Decal, 36 , 7 Inch White	1
	801248	• Decal, 36 , 7 Inch Black	1
14	C-4V113	• Decal, A Letter Adhesive	1
15	C-4V115	• Decal, C Letter Adhesive	1
16	C-4V116	• Decal, D Letter Adhesive	1
17	C-4V114	• Decal, B Letter Adhesive	1
-18	800766	• Kit, XT 36 / XXT 32 Decal	1
19	800051	•• Nameplate, PTO	1
20	800059	•• Plate, PTO Operation	1
21	800034	•• Decal, Oil Level	2
22	800033	•• Decal, Water	1
23	800915	•• Decal, Danger, Stay Clear	1
24	800919	•• Decal, Warning, Stand Clear of Outriggers when activating	4
-25	800920	•• Decal, Warning, Clear Area Before Activating Outriggers	2
26	800439	•• Decal, Control Box Panel	1
27	801113	•• Decal, Gauge	1
28		•• Decal, A B	1
29	800926	•• Decal, Warning, Do Not Operate This Machine without	1
30	800929	•• Decal, Warning	1
31	800925	•• Decal, Warning, Do Not Operate This Machine without	1
32	800930	•• Decal, ACPA Hand Signals	1
33	800913	•• Decal, Danger, Electrocutation Hazard	1
34	800875	•• Nameplate, Agitator / Water	1
35	800918	•• Decal, Warning, Do Not Stand on Hopper Grate	2
36	800917	•• Decal, Warning, Keep Hand Out of Hopper and Valve	2
37	800924	•• Decal, Warning, This Machine is Remote Controlled and May	1
38	800931	•• Decal, ACPA Member	1
39	800922	•• Decal, Warning, Before Opening a Blocked Pipeline, Relieve	1
40	800923	•• Decal, Warning, Use Retaining Pins in all Delivery System	1
41	800928	•• Decal, Warning, Total Weight of all Hanging Hoses, Reducers	1
42	800927	•• Decal, Warning, Do Not Use the Boom as a Crane or Hoist.	1
43	800921	•• Decal, Warning, Do Not Operate at Pressures Exceeding	1
-44	800914	•• Decal, Danger, Electrocutation Hazard	1
-45	800916	•• Decal, Warning, Keep Hand Out of Water Box	1
46	75009	•• Nameplate, REED , Serial No.	1

DASH (-) ITEM NOT ILLUSTRATED

REVISION:

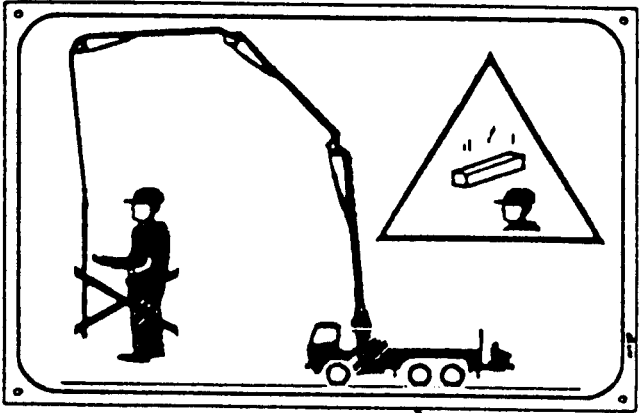

(A)

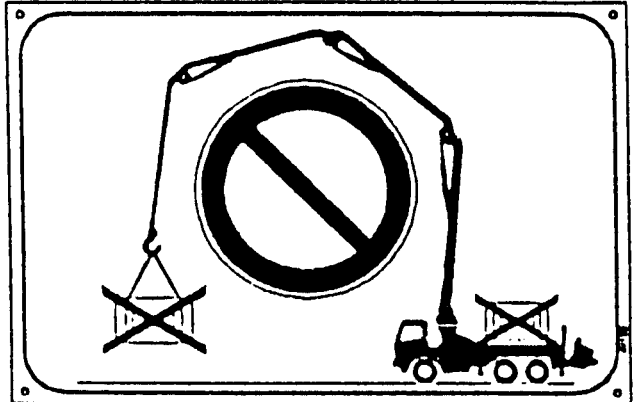

(B)

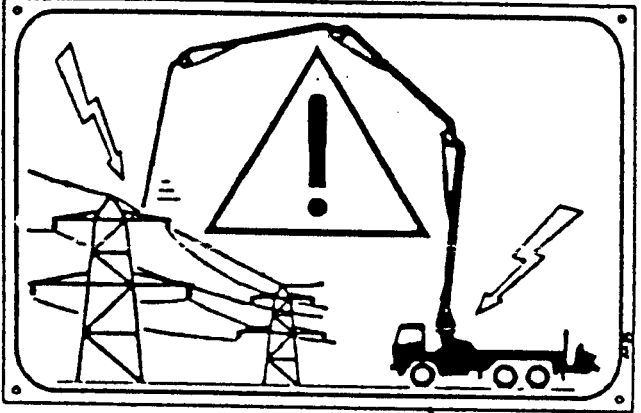

(C)

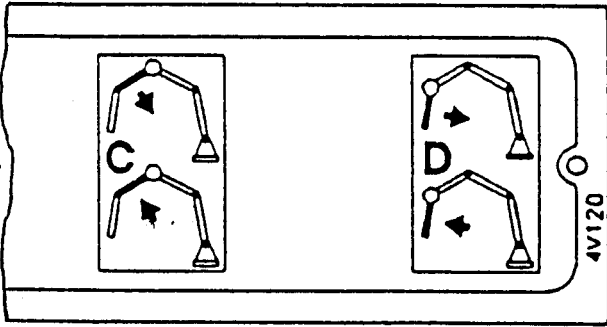

(D)

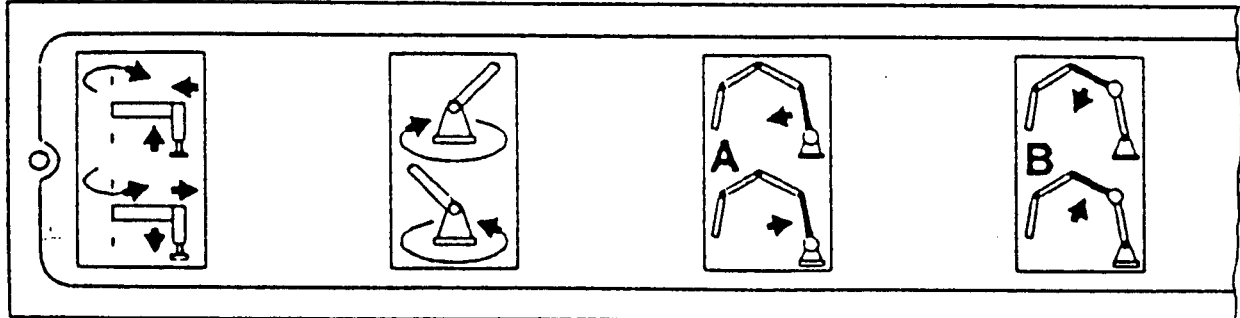

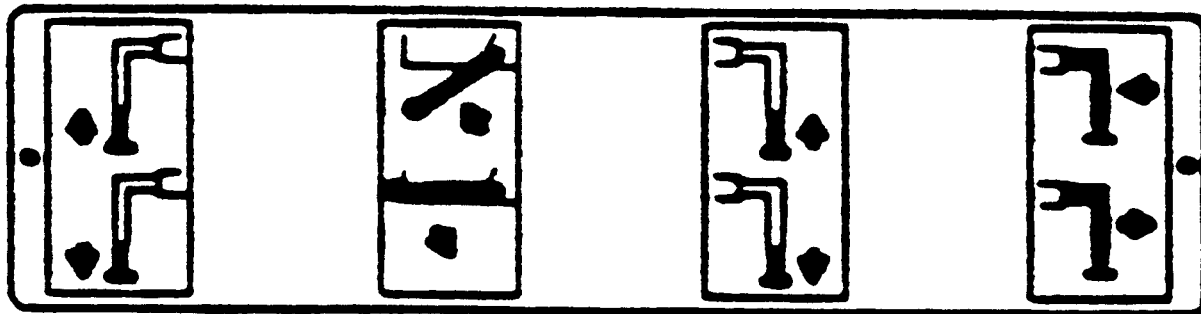

(E)

8

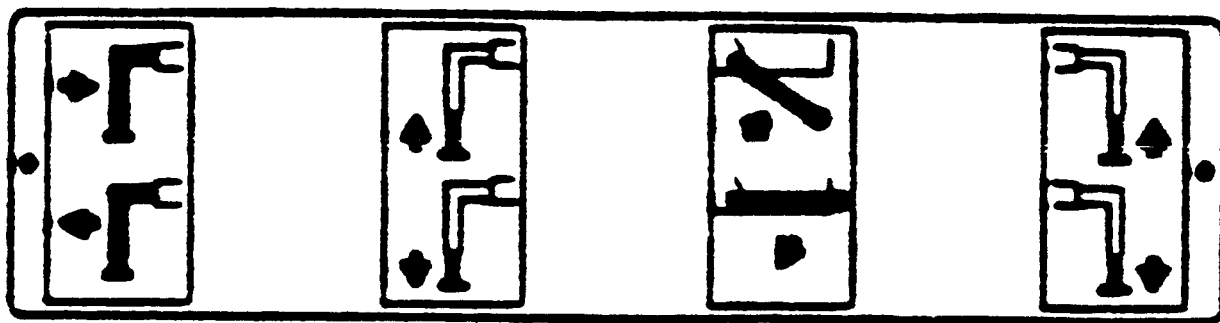

(F)

9

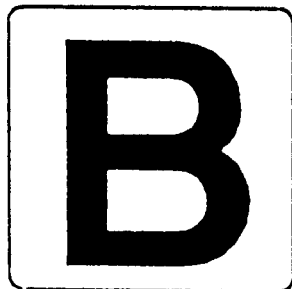

17

(K)

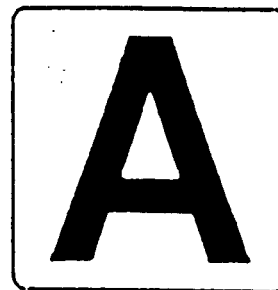

14

(G)

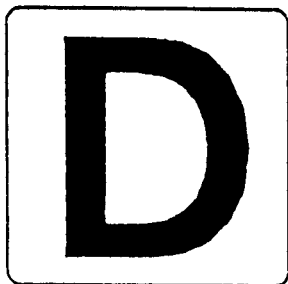

16

(J)

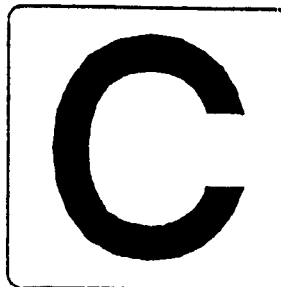

(H)

15

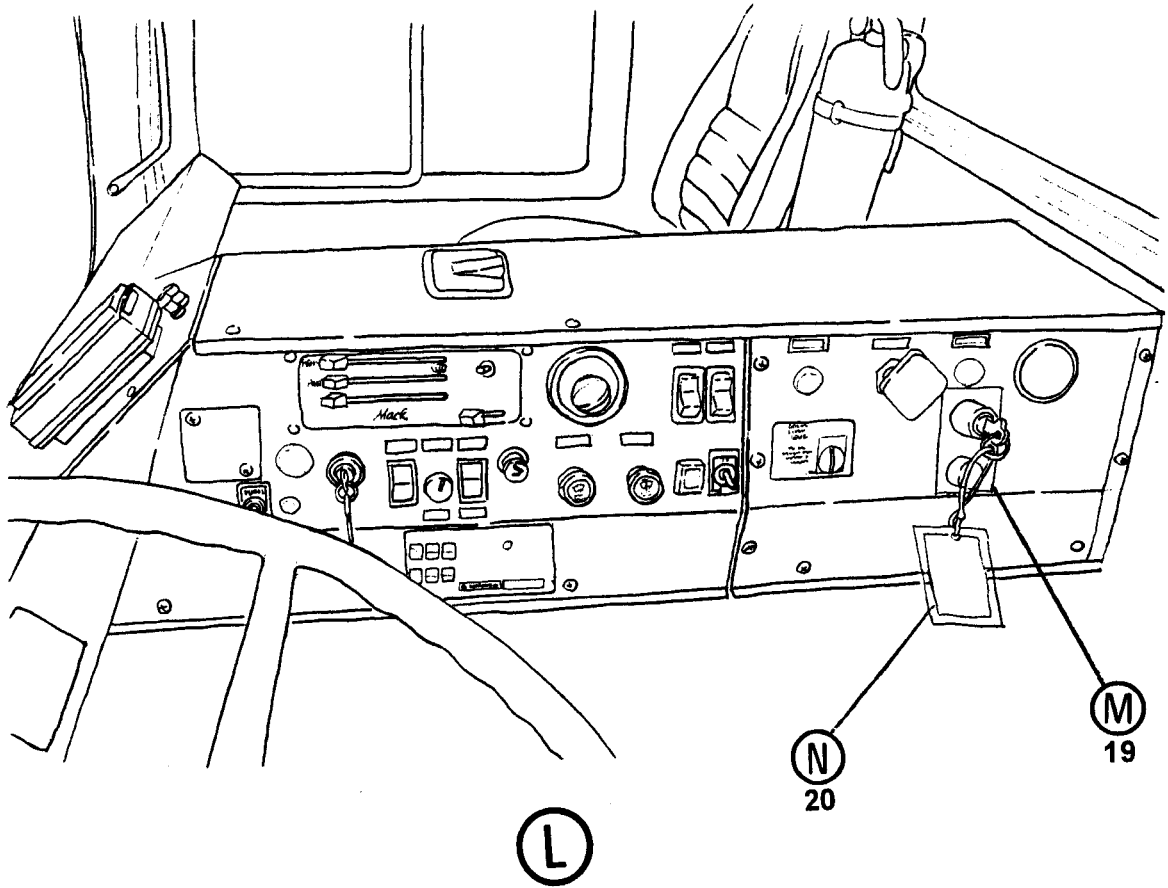

TO OPERATE PUMP AND BOOM

1. POSITION TRUCK AND SET PARKING BRAKE.
2. DEPRESS CLUTCH AND SHIFT TO 7TH GEAR HIGH.
3. TURN PTO ON.
4. RELEASE CLUTCH TO ENGAGE PUMPS.
5. SET THROTTLE AT 1600 RPM MAXIMUM.

TO RETURN TO DRIVING MODE

1. RETURN THROTTLE TO IDLE.
2. DEPRESS CLUTCH AND TURN PTO OFF.
3. SHIFT TO NUETRAL AND RELEASE CLUTCH.

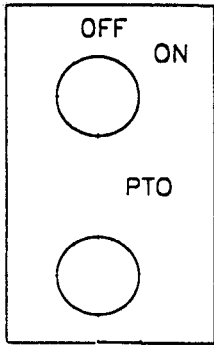

20

19

(N)

(M)



⚠ DANGER

Stay clear.
Contact will result in
death or serious injury
if the unit becomes
electrically charged.

800915

23

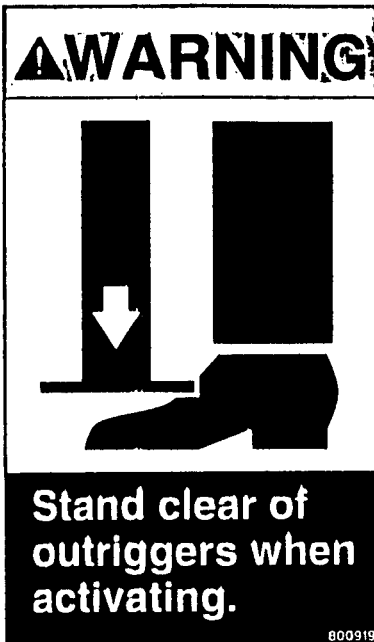

25

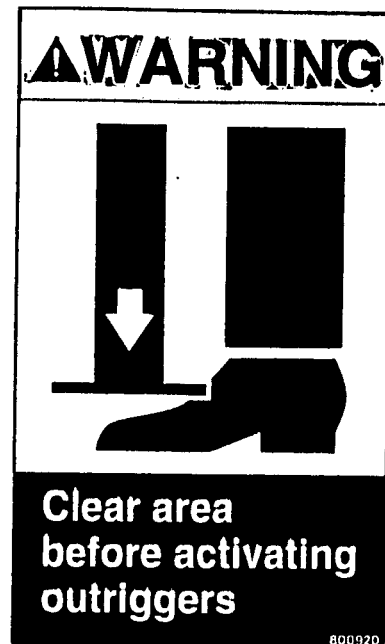

24



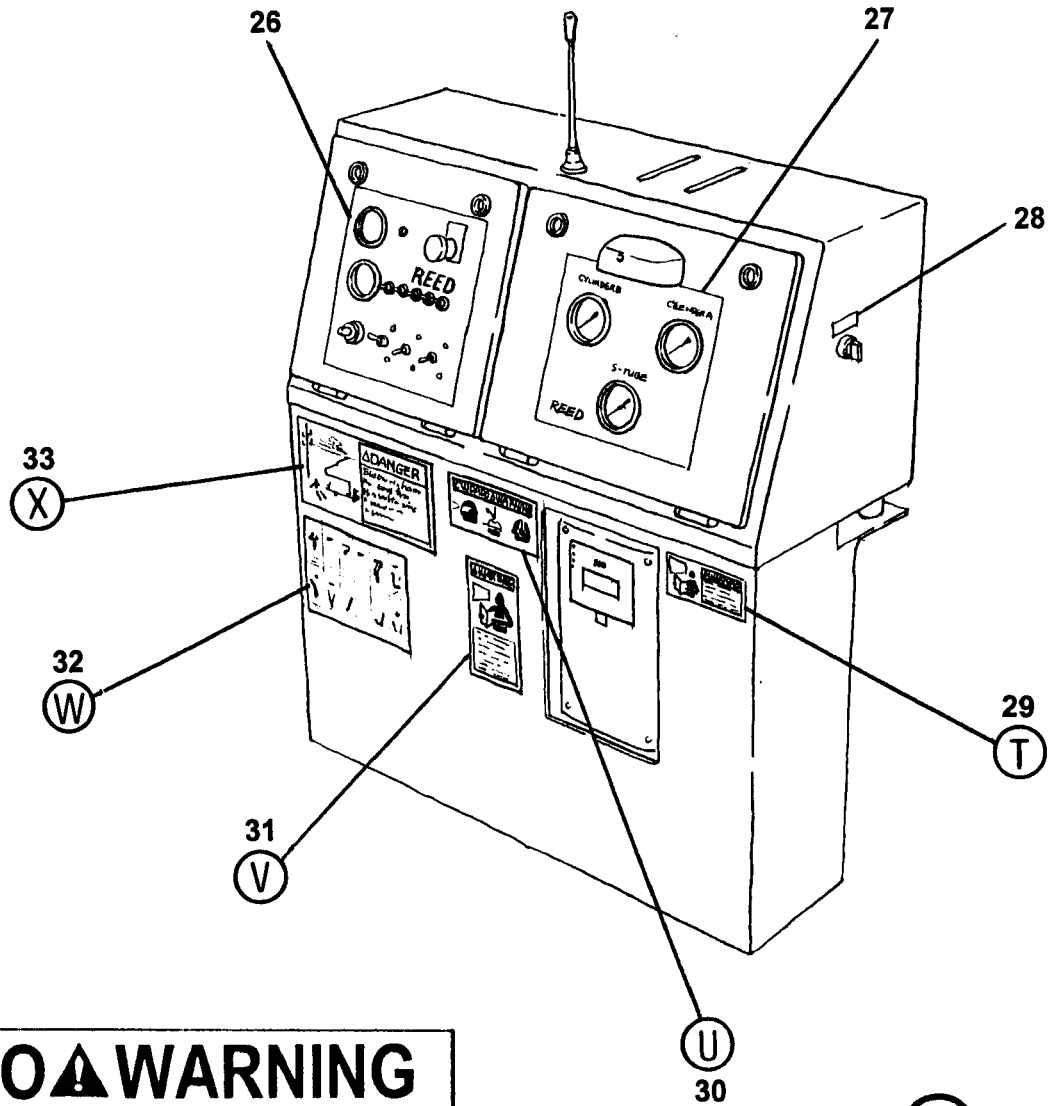

CUIDADO ⚠ WARNING

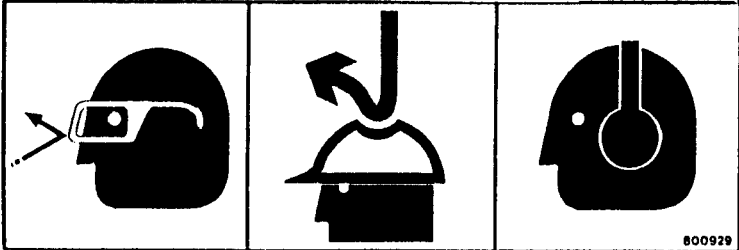

U

30

29

T

⚠ WARNING
Do not operate this machine without training. Understand the warnings in safety manuals and on decals.

⚠ WARNING



31

**Do not operate
this machine
without training.
Understand the
warnings in
safety manuals
and on decals.**



800925



32



1. BOOM UP



2. BOOM DOWN



3. BOOM LEFT



4. BOOM RIGHT



5. OPEN OR
EXTEND BOOM



6. CLOSE OR
RETRACT BOOM



7. STOP BOOM



8. START PUMP
SPEED UP



9. SLOW PUMP
DOWN



10. STOP PUMP



11. LITTLE BIT



12. ADD WATER
4-GALLONS



13. ALL DONE
CLEAN UP

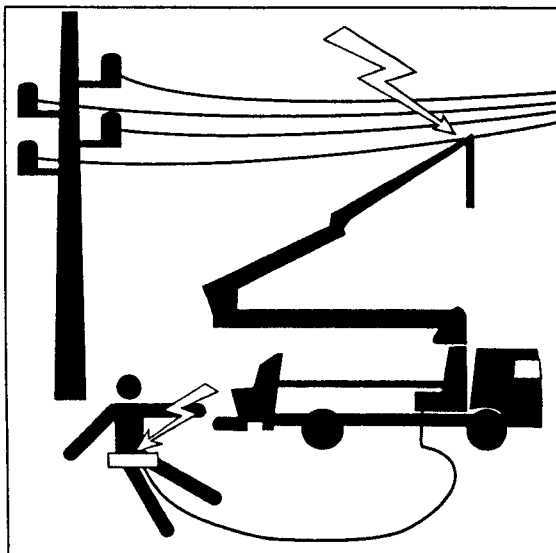

⚠ DANGER

Electrocution hazard.
Stay back from
high voltage wires
at least 17 feet
(5 meters).

800913



33

⚠ WARNING

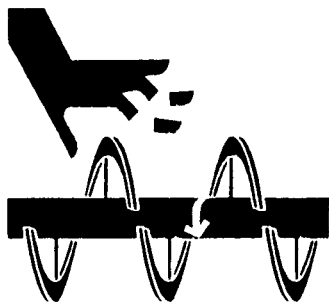

Keep hands out
of hopper and
valve assembly.
See operation
manual if access
is required.

800917



36

⚠ WARNING



Do not stand on
hopper grates.

800918



35

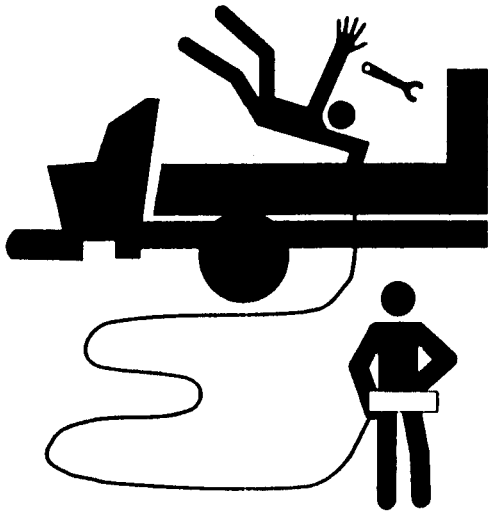

! WARNING

This machine is remote controlled and may start at any time. Stop engine before servicing unit.

800924

AA

37



! WARNING

Use retaining pins in all delivery system snap clamps.

800923

AD

40



38

AB

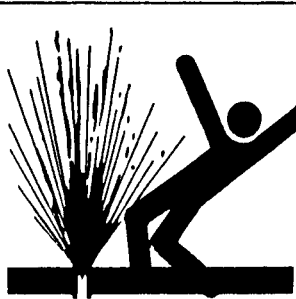

! WARNING

Before opening a blocked pipeline, relieve pressure by reversing pump. See manual.

800922

AC

39

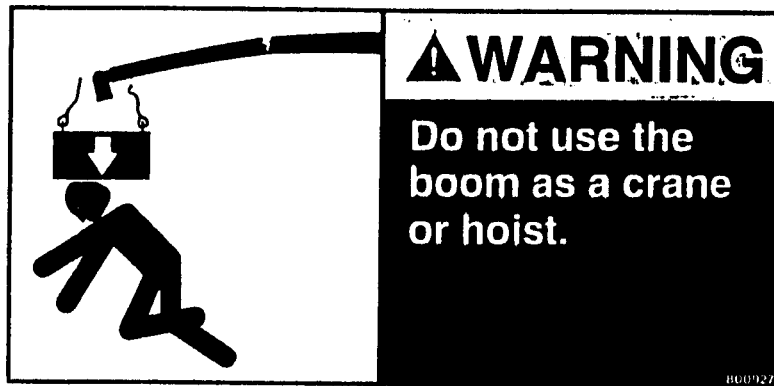
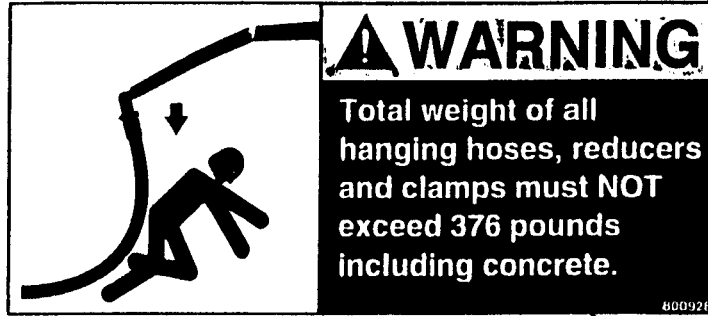

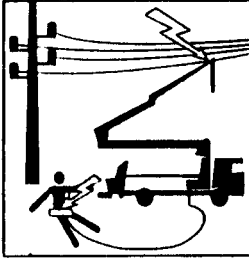

⚠ DANGER

Electrocution hazard.
Stay back from high
voltage wires at least
17 feet (5 meters).

800914

44

AH



⚠ WARNING

Keep hands out of
waterbox.
Stop engine/motor if
access is required.
Keep guards in place.

800916

45

AJ

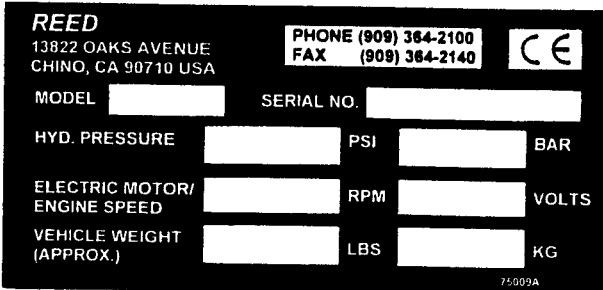

REED
13822 OAKS AVENUE
CHINO, CA 90710 USA

PHONE (909) 364-2100
FAX (909) 364-2140

CE

MODEL SERIAL NO.

HYD. PRESSURE PSI BAR

ELECTRIC MOTOR/
ENGINE SPEED RPM VOLTS

VEHICLE WEIGHT
(APPROX.) LBS KG

74009A

46

AK

ITEM NO.	REED'S PARTS NO.	DESCRIPTION	QTY
-1	10-02	Assembly, Decal (See Group 10, Figure 01 for NHA)	Ref
2	800442	• Decal, REED , 6 Inch Black	1
3	C-4V107	• Plate, Danger Of Falling Object	1
4	C-4V106	• Plate, Never Use As Crane	1
5	C-4V105	• Plate, Death Hazard	1
6	801069	• Decal, REED , 12 Inch White	2
7	802272	• Nameplate, Boom Valve	1
8	802271	• Nameplate, XT 36 Right Side Outrigger	1
9	802270	• Nameplate, XT 36 Left Side Outrigger	1
10	801066	• Decal, XT , 4 Inch White	1
	801246	• Decal, XT , 4 Inch Black	1
11	801067	• Decal, XT , 5 Inch White	1
	801246	• Decal, XT , 4 Inch Black	1
12	801071	• Decal, 36 , 8 Inch White	1
	801248	• Decal, 36 , 7 Inch Black	1
13	801072	• Decal, 36 , 7 Inch White	1
	801248	• Decal, 36 , 7 Inch Black	1
14	C-4V113	• Decal, A Letter Adhesive	1
15	C-4V115	• Decal, C Letter Adhesive	1
16	C-4V116	• Decal, D Letter Adhesive	1
17	C-4V114	• Decal, B Letter Adhesive	1
-18	800766	• Kit, XT 36 / XXT 32 Decal	1
19	800051	• • Nameplate, PTO	1
20	800059	• • Plate, PTO Operation	1
21	800034	• • Decal, Oil Level	2
22	800033	• • Decal, Water	1
23	800915	• • Decal, Danger, Stay Clear	1
24	800919	• • Decal, Warning, Stand Clear of Outriggers when activating	4
-25	800920	• • Decal, Warning, Clear Area Before Activating Outriggers	2
26	800439	• • Decal, Control Box Panel	1
27	801113	• • Decal, Gauge	1
28		• • Decal, A B	1
29	800926	• • Decal, Warning, Do Not Operate This Machine without	1
30	800929	• • Decal, Warning	1
31	800925	• • Decal, Warning, Do Not Operate This Machine without	1
32	800930	• • Decal, ACPA Hand Signals	1
33	800913	• • Decal, Danger, Electrocution Hazard	1
34	800875	• • Nameplate, Agitator / Water	1
35	800918	• • Decal, Warning, Do Not Stand on Hopper Grate	2
36	800917	• • Decal, Warning, Keep Hand Out of Hopper and Valve	2
37	800924	• • Decal, Warning, This Machine is Remote Controlled and May	1
38	800931	• • Decal, ACPA Member	1
39	800922	• • Decal, Warning, Before Opening a Blocked Pipeline, Relieve	1
40	800923	• • Decal, Warning, Use Retaining Pins in all Delivery System	1
41	800928	• • Decal, Warning, Total Weight of all Hanging Hoses, Reducers	1
42	800927	• • Decal, Warning, Do Not Use the Boom as a Crane or Hoist.	1
43	800921	• • Decal, Warning, Do Not Operate at Pressures Exceeding	1
-44	800914	• • Decal, Danger, Electrocution Hazard	1
-45	800916	• • Decal, Warning, Keep Hand Out of Water Box	1
46	75009	• • Nameplate, REED , Serial No.	1

DASH (-) ITEM NOT ILLUSTRATED

REVISION:

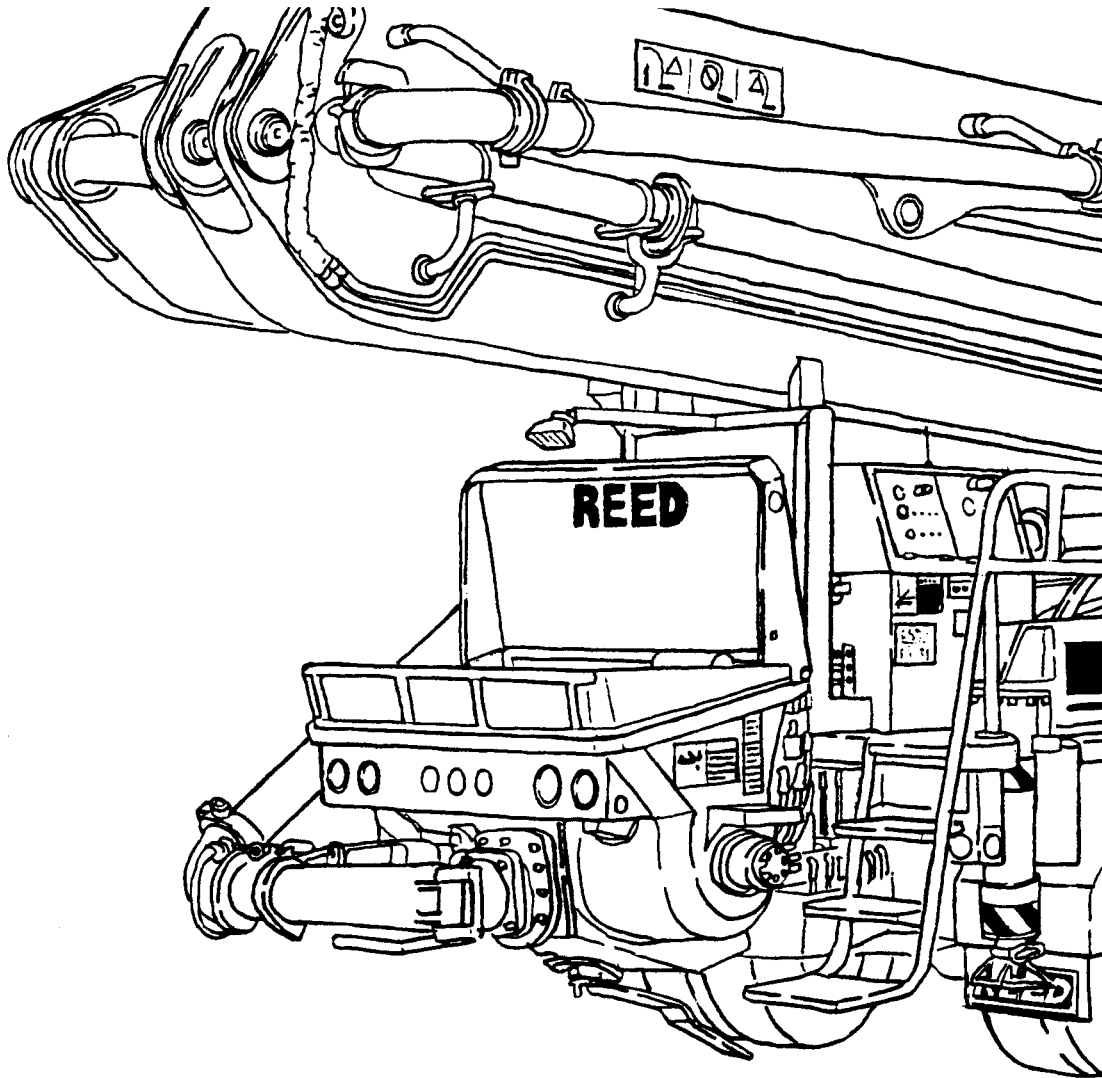

REED TRUCK MOUNTED CONCRETE BOOM PUMP MODEL XT 36 ILLUSTRATED PARTS MANUAL GROUP 20 HOPPER INSTALLATION CONTAINS THE FOLLOWING FIGURES:

FIGURE 00	TABLE OF CONTENTS
FIGURE 01	HOPPER INSTALLATION
FIGURE 02	LUBRICATION PUMP ASSEMBLY
FIGURE 03	CENTRAL LUBRICATION SYSTEM
FIGURE 04	HOPPER VIBRATION ASSEMBLY
FIGURE 05	AGITATOR ASSEMBLY
FIGURE 06	AGITATOR DRIVE MOTOR ASSEMBLY
FIGURE 07	HOPPER OUTLET ASSEMBLY

REED

HOPPER INSTALLATION

XT 36
PARTS
GROUP 20
FIGURE 01
PAGE 01

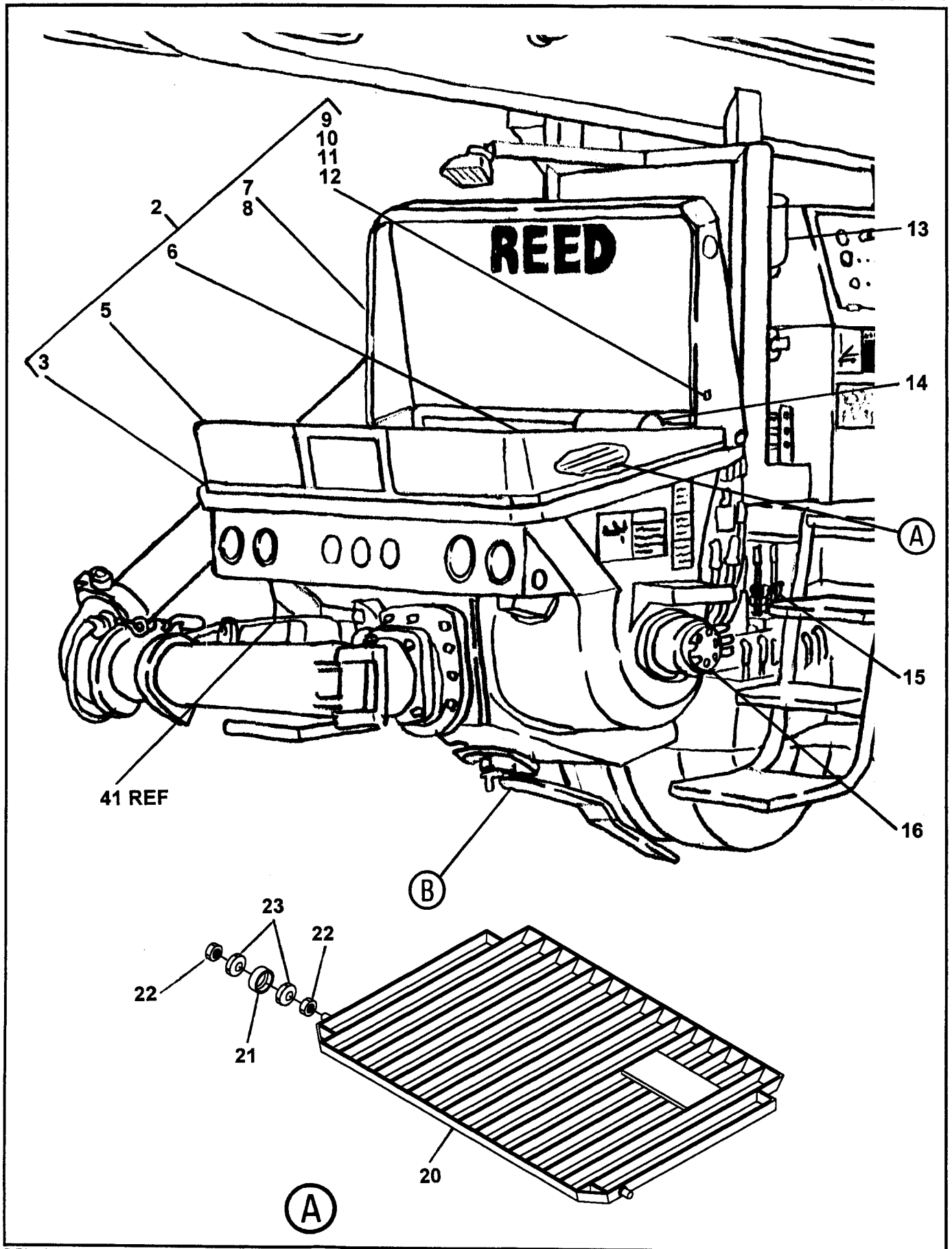

ITEM NO.	REED'S PARTS NO.	DESCRIPTION	QTY
-1	20-01	Installation, Hopper (See Group 10, Figure 01 for NHA)	Ref
2	800419	• Group, Splash Guard	1
3	800398	• • Bar, Splash Guard	1
-4	800402	• • Strip, Silicon 0.53	1
5	800399	• • Rubber Flap, Splash Guard	1
6	800416	• • Rubber, Splash Guard 10 FT	1
7	79056	• • Handle, Splash Guard	1
8	800395	• • Weldment, Splash Guard	1
9	800400	• • Pivot plate, Splash Guard	2
10	800401	• • Plunger, Spring	2
11	800417	• • Pin	1
12	800418	• • Lanyard	1
13	B-184000	• Assembly, Central Lubrication System (See Group 20, Figure 02 for DET)	1
14	71429	• Assembly, Hopper Vibration (See Group 20, Figure 04 for DET)	1
15	W-100124	• Assembly, Agitator/Wash Control Valve	1
-16	B-254120	• Assembly, Agitator (See Group 20, Figure 05 for DET)	1
-17	W-104067	• Buffer, Grid Rubber	4
-18	W-101559	• Washer (attaching parts)	4
19	W-101847	• Nut, Cap (attaching parts)	8
20	B-224035	• Grid	1
21	W101849	• Buffer, Rubber	2
22	W-101559	• Washer	4
23	B-223011	• Nut, Cap	4

DASH (-) ITEM NOT ILLUSTRATED



HOPPER INSTALLATION

XT 36
PARTS
GROUP 20
FIGURE 01
PAGE 03

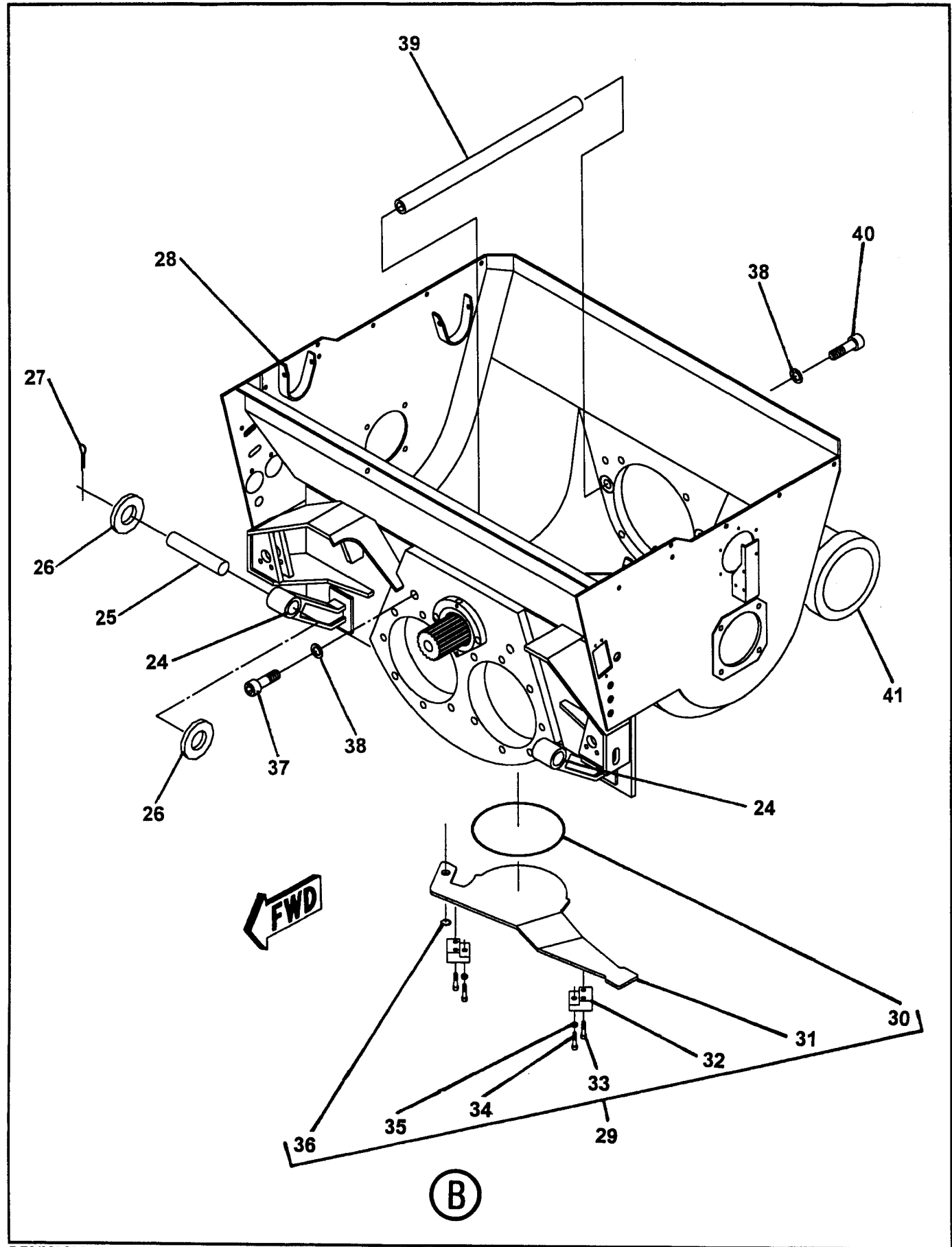

ITEM NO.	REED'S PARTS NO.	DESCRIPTION					QTY
		1	2	3	4	5	
24	W-102489	• Buffer, Rubber					2
25	W-100940	• Pin					2
26	W-103411	• Washer					4
27		• Pin, Cotter					4
28	B-173021	• Weldment, Hopper					1
29	B-173085	• Assembly, Cleaning Cover					1
30	W-102908	• • O-Ring, Round Cord					1
31	B-172130	• • Cover, Cleaning					1
32	B-172126	• • Block, Clamping					2
33	W-102855	• • Screw, M20 (attaching parts)					4
34	B-172218	• • Screw, M20 (attaching parts)					2
35	W-102891	• • Nut, Hex M20 (attaching parts)					2
36	W-102864	• • Ring, Lock					1
37	W-103074	• Screw, Hex					2
38	W-102331	• Washer					4
39	B-174075	• Rod, Tie					2
40	W-103073	• Screw, Hex M24					2
41	20-07	• Assembly, Hopper Outlet (See Group 20, Figure 07 for DET)					1

DASH (-) ITEM NOT ILLUSTRATED



CENTRAL LUBRICATION SYSTEM

XT 36
PARTS
GROUP 20
FIGURE 02
PAGE 01

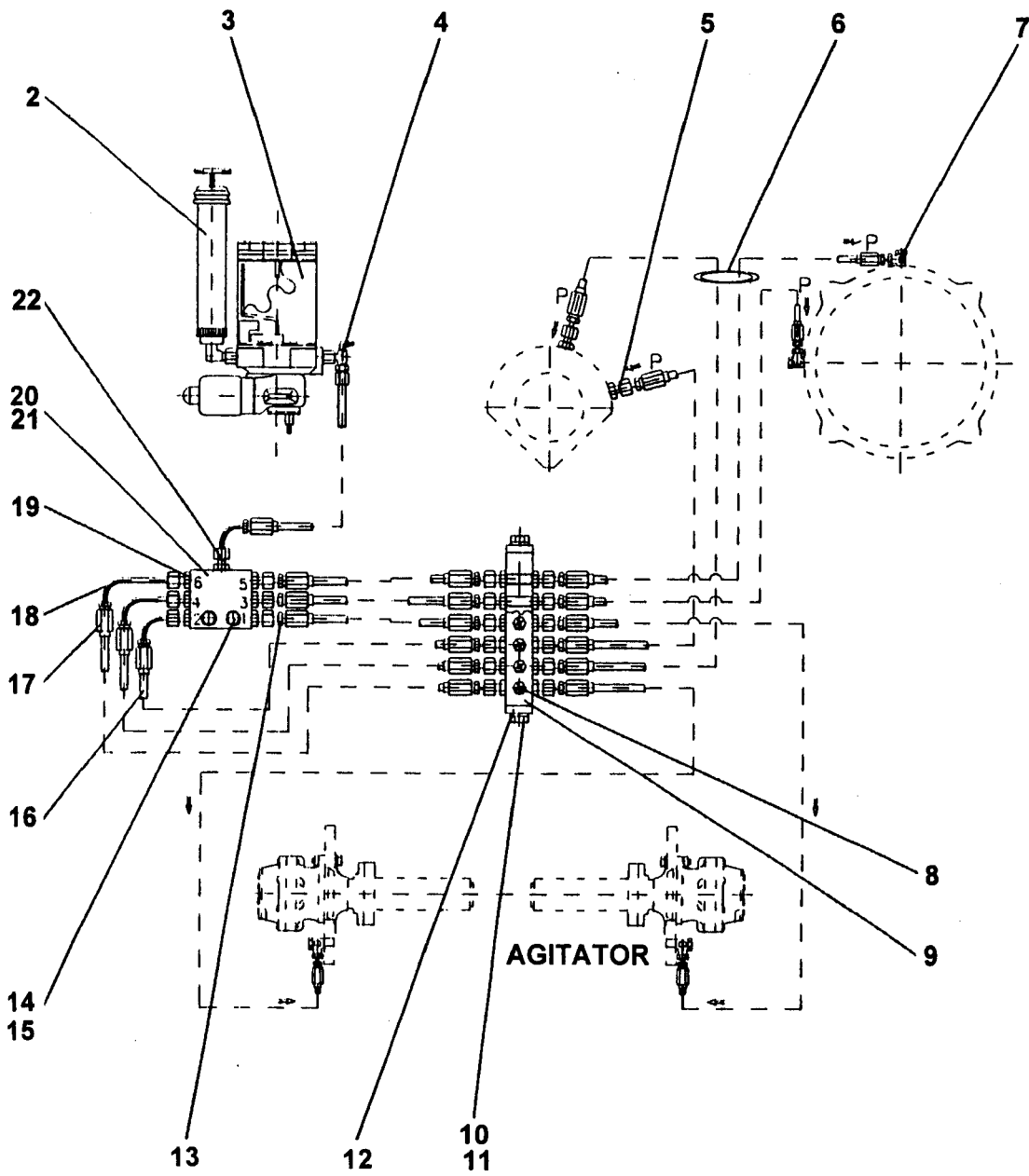

ITEM NO.	REED'S PARTS NO.	DESCRIPTION					QTY
		1	2	3	4	5	
-1	B-184000	System, Central Lubrication (See Group 20, Figure 01 for NHA)					Ref
2	78532	• Gun, Grease					1
3	800065	• Assembly, Lubrication Pump (See Group 20, Figure 03 for DET)					1
4	W-103198	• Valve, Safety					1
5	W-100546	• Coupling, Straight Male Stud					14
6	W-103107	• Tie, Cable					30
7	W-102884	• Elbow, Throttle Free benjo					4
8	W-100303	• Nipple, Grease					6
9	B-184001	• Strip, Lubrication					1
10	W-102873	• Screw, M8					2
11	W-102205	• Washer, A8 Spring					2
12	B-184002	• Plate, Lubrication Mechanism					2
13	W-100253	• Piece, Hose Connection					24
14	W-103847	• Screw, M6 Hex					2
15	W-103000	• Washer, A6 Spring					2
16	W-100255	• Pipe, Plastic					
17	W-100254	• Sleeve, Threaded					30
18	W -102643	• Sleeve, 90 Threaded					30
19	W100299	• Valve, Pipe Stroke					6
20	W-100298	• Distributor, Lubrication					1
21	B-184003	• Plate, Lubrication Distributor Tap					1
22	W-100302	• Coupling, Straight Male Stud					1

DASH (-) ITEM NOT ILLUSTRATED

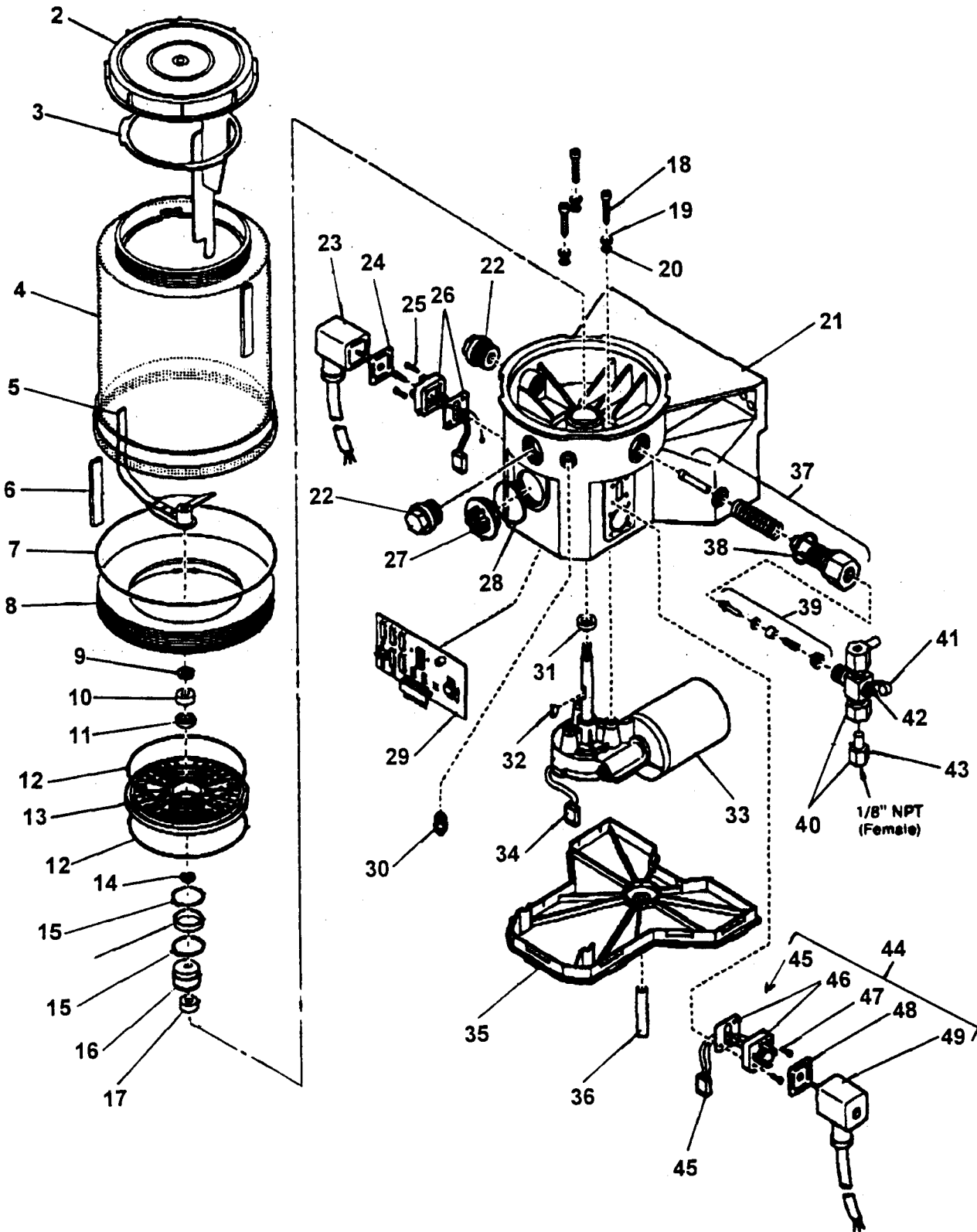

ITEM NO.	REED'S PARTS NO.	DESCRIPTION					QTY
		1	2	3	4	5	
-1	800065	Assembly, Lubrication Pump (See Group 20, Figure 02 for NHA)					Ref
2		• Lid					1
3		• Paddle, Fixed					1
4		• Reservoir					1
5		• Paddle, Stirring					1
6		• Hose					1
7		• O-Ring					1
8		• Adapter					1
9		• Washer					1
10		• Ring, Bearing					2
11		• Bearing					1
12		• O-Ring					2
13		• Plate, Intermediate					1
14		• Shim					1
15		• Ring, Snap					2
16		• Ring, Inner					1
17		• Cam, Eccentric					1
18		• Screw					3
19		• Washer					3
20		• O-Ring					3
21		• Housing, Pump					1
22		• Plug, Closure					2
23		• Socket with Cord					1
24		• Packing, Flat					1
25		• Screw					4
26		• Plug					1
27		• Plug, Sealing					1
28		• O-Ring					1
29		• Board, Printed Circuit					1
30		• Fitting, Grease					1
31		• Seal, Radial					1
32		• Key, Wood Ruff					1
33		• Motor, 12 VDC					1
34		• Plug, Motor					1
35		• Cover, Housing					1

DASH (-) ITEM NOT ILLUSTRATED



LUBRICATION PUMP ASSEMBLY

XT 36
PARTS
GROUP 20
FIGURE 03
PAGE 03

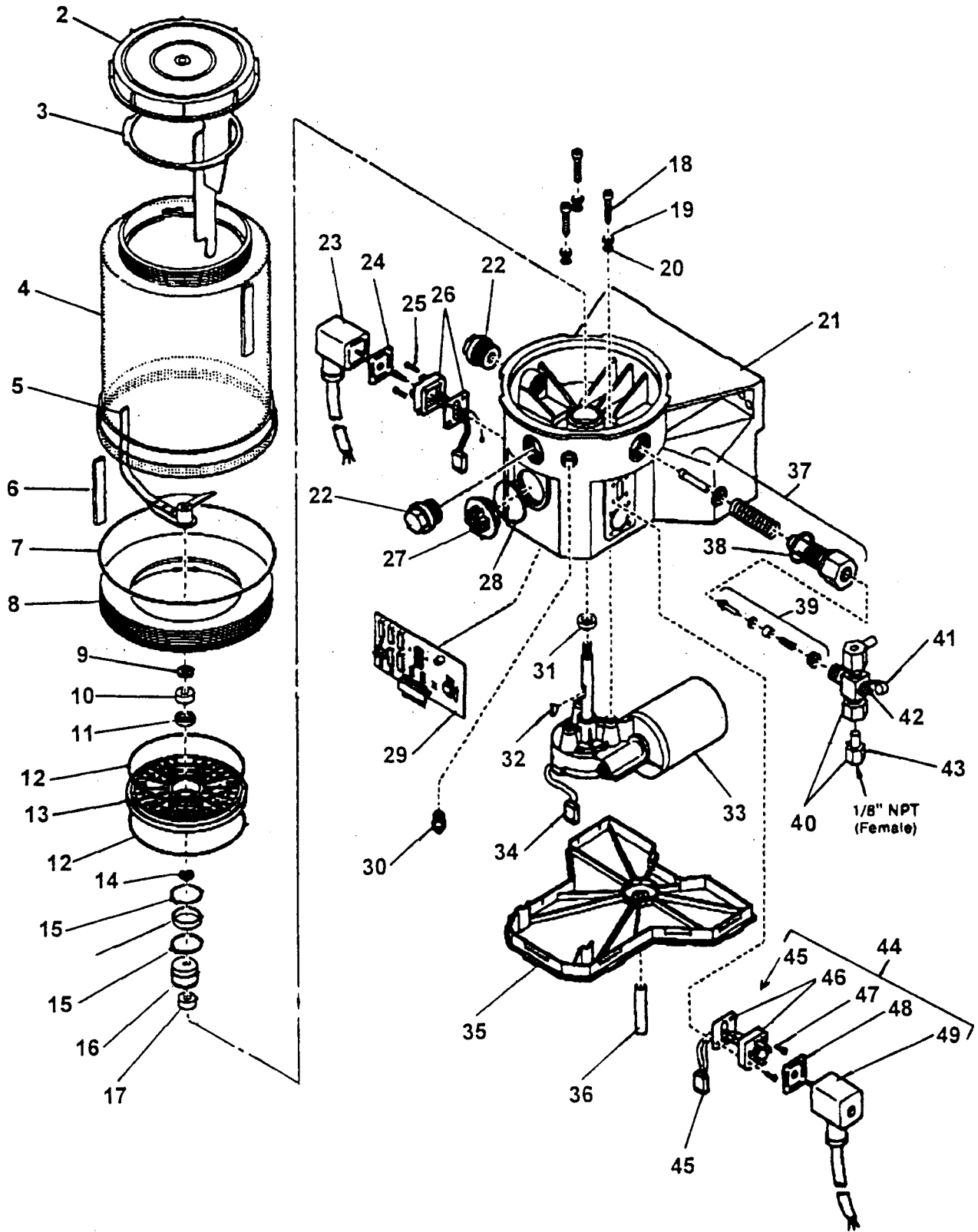

ITEM NO.	REED'S PARTS NO.	1 2 3 4 5	DESCRIPTION	QTY
36		•	Hose	1
37		•	Element, Pump	1
38		•	Gasket	1
39		•	Valve, Check	1
40		•	Assembly, Pressure Release	1
41		•	Cap, Grease	1
42		•	Fitting, Grease	1
43		•	Adapter for Relief	1
44		•	Assembly, Optional Pressure Relief Valve	1
45		• •	Cord, Optional Power	1
46		• •	Plug, Optional	1
47		• •	Screw, Optional	4
48		• •	Packing, Optional Flat	1
49		• •	Socket, Optional	1

DASH (-) ITEM NOT ILLUSTRATED



HOPPER VIBRATOR ASSEMBLY

XT 36
PARTS
GROUP 20
FIGURE 04
PAGE 01

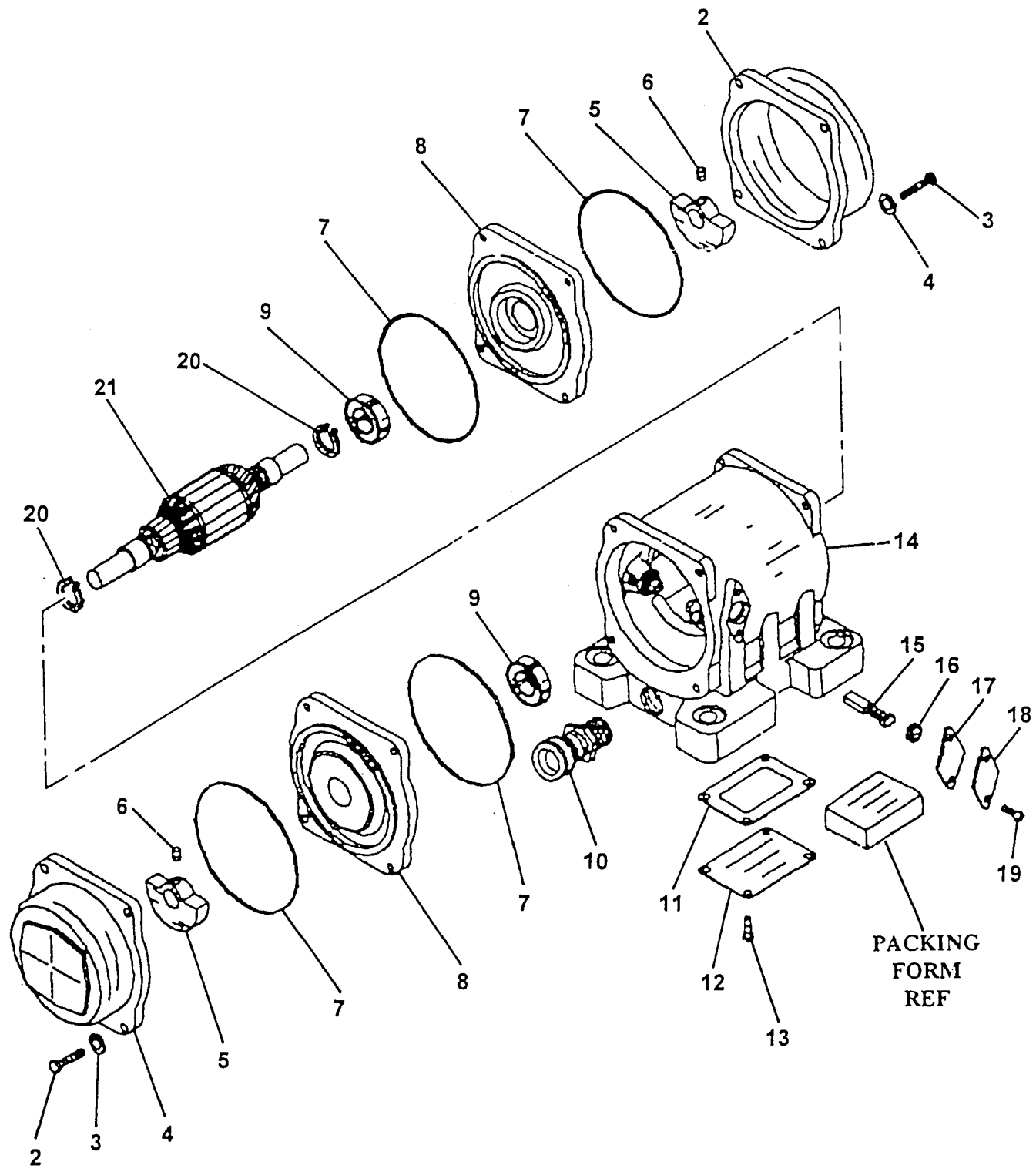

ITEM NO.	REED'S PARTS NO.	DESCRIPTION	QTY
-1	71429	Assembly, Hopper Vibrator (See Group 20, Figure 01 for NHA)	Ref
2		• Cap, End	2
3		• Bolt (attaching parts)	8
4		• Washer, Lock (attaching parts)	8
5		• Weight	2
6		• Screw, Set (attaching parts)	2
7		• O-Ring	4
8		• Bell, End	2
9		• Bearing	2
10		• Holder, Cord	1
11		• Gasket	1
12		• Cover, Box	1
13		• Screw (attaching parts)	4
14		• Sub-Assembly, Housing	1
15		• Brush	1
16		• Cap, Brush	2
17		• Gasket	2
18		• Cover, Brush	2
19		• Screw (attaching parts)	4
20		• Ring, Snap	2
21		• Assembly, Armature	1

DASH (-) ITEM NOT ILLUSTRATED



AGITATOR ASSEMBLY

XT36
PARTS
GROUP 20
FIGURE 05
PAGE 01

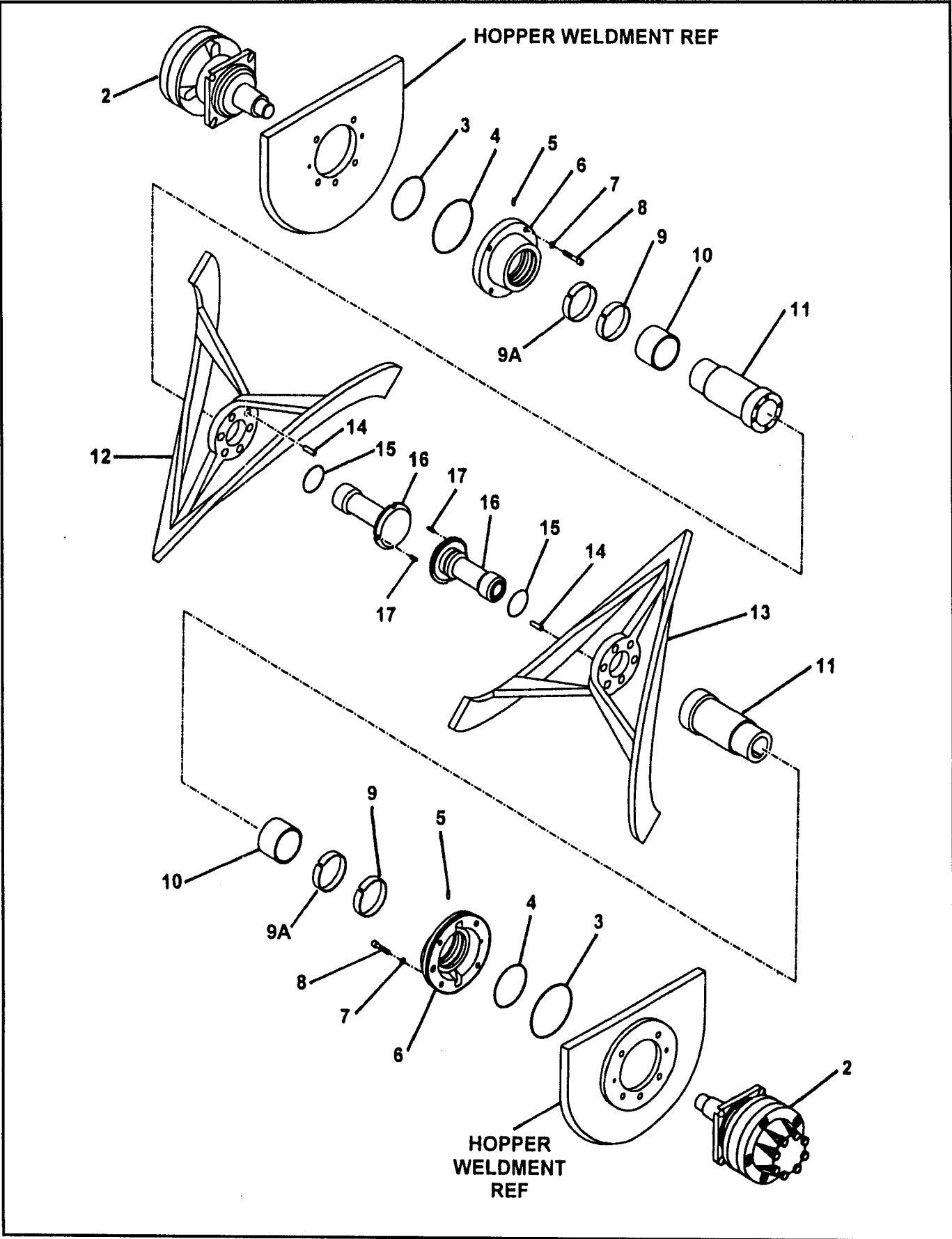



AGITATOR ASSEMBLY

XT36
PARTS
GROUP 20
FIGURE 05
PAGE 02

ITEM NO.	REED'S PARTS NO.	DESCRIPTION	QTY
-1	B-254120	Assembly, Agitator (See Group 20, Figure 01 for NHA)	Ref
2	W-101240	• Assembly, Agitator Drive Motor (See Group 20, Figure 08 for DET)	1
3	W-103064	• O-Ring	2
4	W-103063	• O-Ring	2
5	W-1004909	• Screw, M5 Set	2
6	B-254101	• Assembly, Flange	2
7	W-102962	• Washer	8
8	W-103062	• Screw, M12 Hex	8
9	W-102544	• Ring, Groove-Outer	2
9A	B-253029	• Ring, Groove-Inner	2
10	B-254104	• Sleeve, Wear	2
11	B-254102	• Shaft	2
12	B-254105	• Agitator, Left	1
13	B-254106	• Agitator, Right	1
14	W-103065	• Pin 10m	12
15	W-103249	• O-Ring	2
16	B-254103	• Nut	2
17	W-103106	• Sleeve, Clamping	4

DASH (-) ITEM NOT ILLUSTRATED



AGITATOR DRIVE MOTOR ASSEMBLY

XT 36
PARTS
GROUP 20
FIGURE 06
PAGE 01

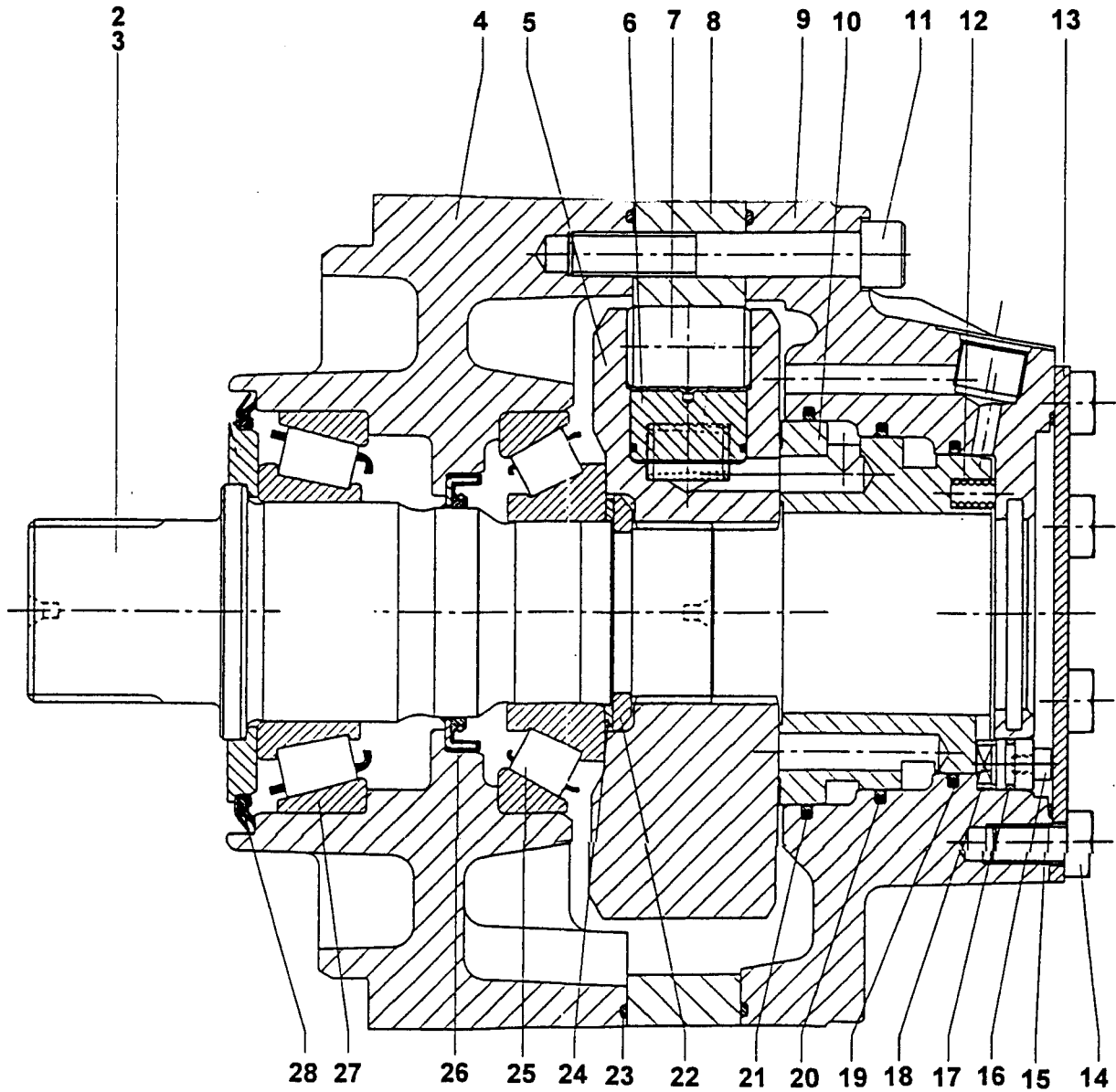

ITEM NO.	REED'S PARTS NO.	1 2 3 4 5	DESCRIPTION	QTY
-1	W-101240		Assembly, Agitator Drive Motor (See Group 20, Figure 05 for NHA)	Ref
2			• Assembly, Auger Drive Motor	1
3			• Shaft	1
4			• Case, Front	1
5			• Block, Cylinder	1
6			• Piston	8
7			• Roller	8
8			• Cam	1
9			• Case, Rear	1
10			• Ring, Distributor	1
11			• Screw, Cap M12	12
12			• Spring	6
13			• Plate, Cover	1
14			• Screw, Hex M10	8
15			• O-Ring	1
16			• Screw, Cap M5	1
17			• O-Ring	1
18			• Pin, Stop	1
19			• Seal, Rod	1
20			• Seal, Rod	1
21			• Seal, Rod	1
22			• Ring, Split	1
23			• O-Ring	2
24			• Washer	1
25			• Bearing	1
26			• Seal, Shaft	1
27			• Bearing	1
28			• Seal, Face	1

DASH (-) ITEM NOT ILLUSTRATED

CONCRETE DECK PIPE LINE ASSEMBLY
(SEE GROUP 90, FIGURE 11 FOR REF)

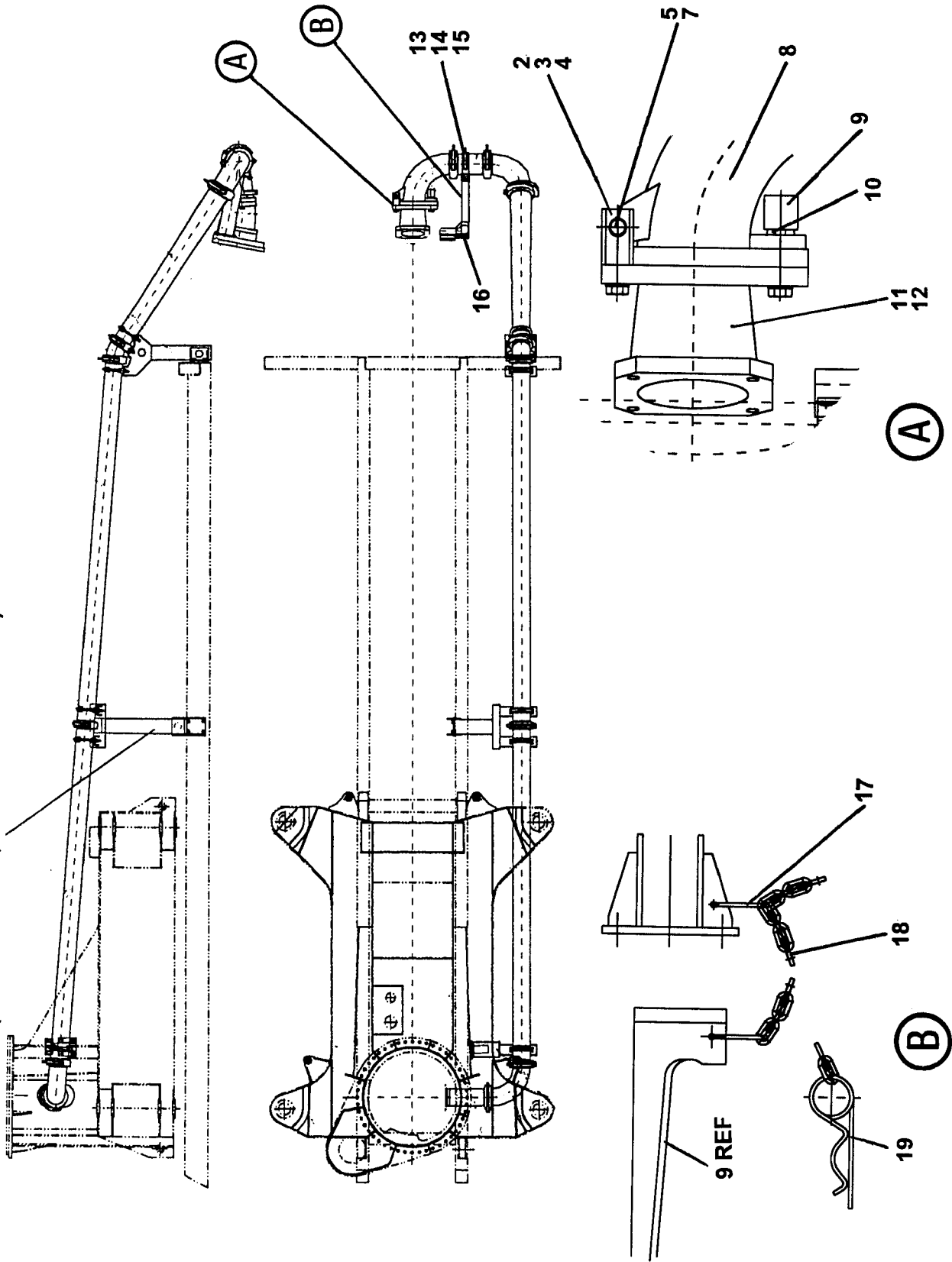

ITEM NO.	REED'S PARTS NO.	DESCRIPTION					QTY
		1	2	3	4	5	
-1	20-07	Assembly, Hopper Outlet (See Group 20, Figure 01 for NHA)					Ref
2	B-194049	• Hinge					2
3	W-102848	• Screw, M24 Hex Head					3
4	W-102331	• Washer					3
5	W-100694	• Ring, Snap					2
-6	B-194065	• Sub- Assembly, Hopper Outlet					1
7	B-194050	• • Bolt					1
8	B-191015	• • Elbow, Reducer					1
9	B-194046	• • Wedge, Locking					1
10	B-194045	• • Bolt, Locking					1
11	B-191010	• • Reducer					1
12	W-104025	• • O-Ring, Hopper Elbow					1
13	W-101779	• • Coupling, 6 Inch Clamp					3
14	W-100690	• • Elbow, 6 Inch					1
15	W-101545	• • O-Ring					3
16	B-194053	• • Coupling, Delivery Line Snap					1
17	W-103731	• S-Hook					2
18	W-103732	• Chain					1
19	W-103733	• Pin, Spring					1

DASH (-) ITEM NOT ILLUSTRATED



**MODEL XT 36 TRUCK MOUNTED
CONCRETE BOOM PUMP
ILLUSTRATED PARTS MANUAL**

**XT 36
PARTS
GROUP 20
FIGURE 08
PAGE 01**

THIS PAGE INTENTIONALLY LEFT BLANK.

REED TRUCK MOUNTED CONCRETE BOOM PUMP MODEL **XT 36** ILLUSTRATED PARTS MANUAL GROUP 30 HYDRAULIC TANK INSTALLATION CONTAINS THE FOLLOWING FIGURES:

- FIGURE 00** TABLE OF CONTENTS
- FIGURE 01** TANK INSTALLATION
- FIGURE 02** WATER SYSTEM GROUP
- FIGURE 03** WASH WATER PUMP ASSEMBLY
- FIGURE 04** WATER PUMP MOTOR ASSEMBLY
- FIGURE 05** HYDRAULIC TANK ASSEMBLY
- FIGURE 06** OIL COOLER MANIFOLD ASSEMBLY

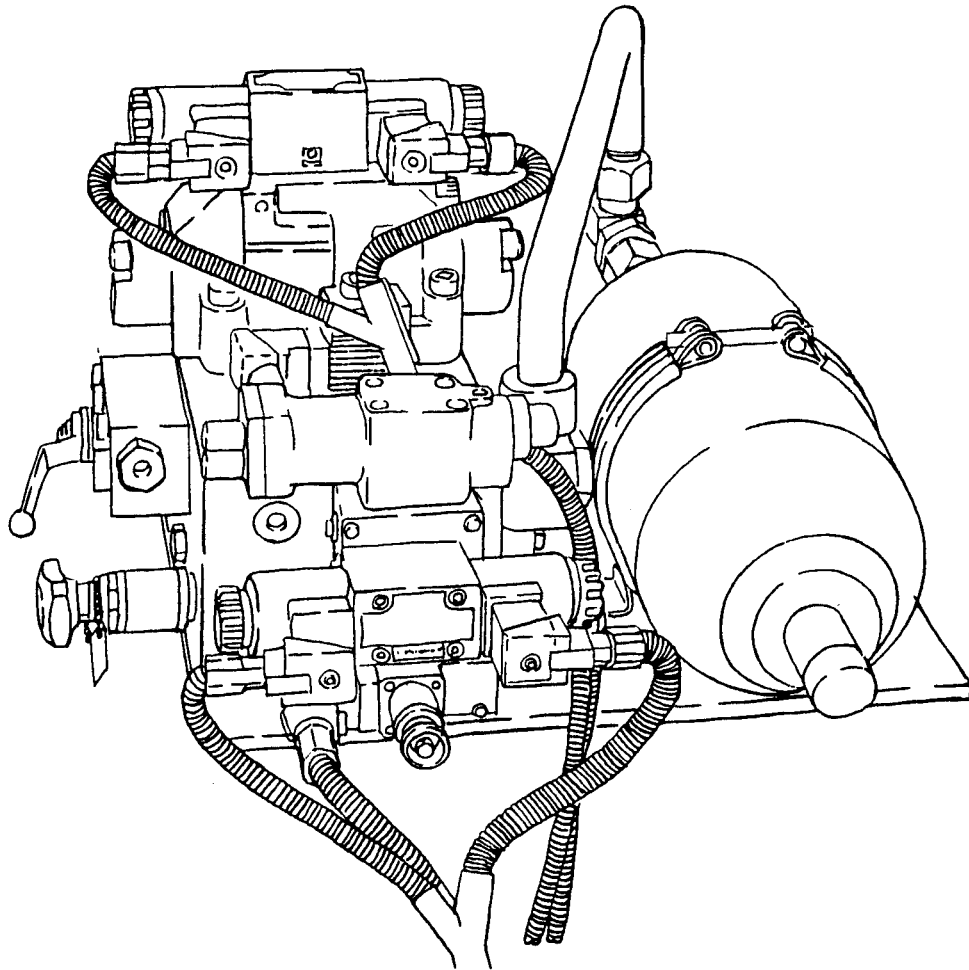



TANK INSTALLATION

XT 36
PARTS
GROUP 30
FIGURE 01
PAGE 01

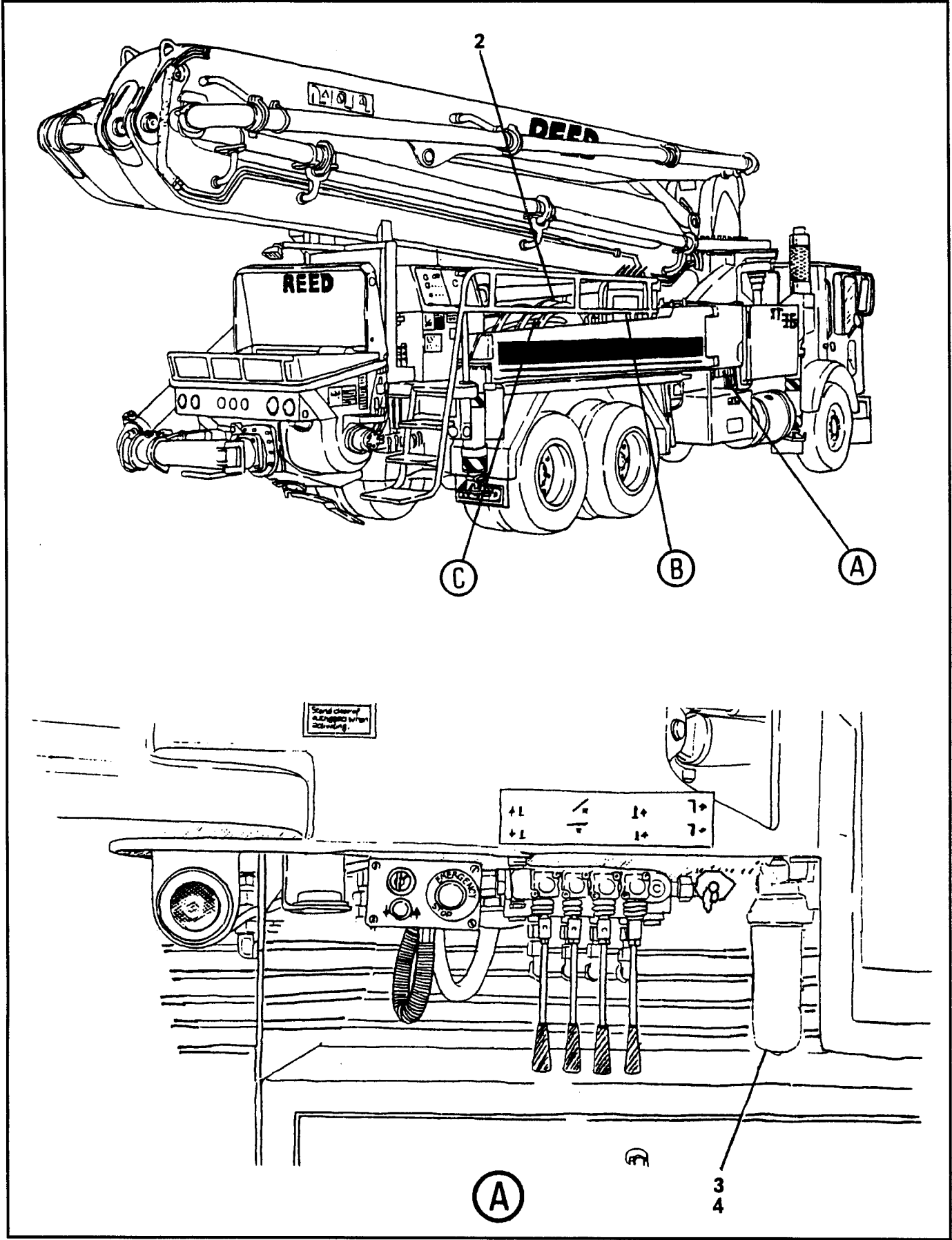

REVISION:

ITEM NO.	REED'S PARTS NO.	DESCRIPTION	QTY
-1	30-01	Installation, Tank (See Group 10, Figure 01 for NHA)	Ref
2	30-02	• Group, Water System (See Group 30, Figure 02 for DET)	1
3	W-105526	• Assembly, Boom High Pressure Filter	1
4	800446	• • Element, Boom High Pressure Filter	1
5	801925	• Elbow, Temperature Sensor	1
6	W-105568	• Sensor, 55 C Temperature	1
7	801814	• Channel, Oil Cooler Bracket	1
8	801868	• Assembly, Hydraulic Oil Cooler	1
9	801935	• Assembly, Hydraulic Tank (See Group 30, Figure 05 for DET)	1
10	802281	• Assembly, Oil Cooler Manifold (See Group 30, Figure 06 for DET)	1
11	801487-006	• Assembly, Tube	1
12	W-104847	• Assembly, Swing Tube Manifold	1
13	W-105573	• Assembly, Swing Tube Circuit Solenoid Valve	1
14	W-105581	• • Pilot, Solenoid Valve	1
15	W-105576	• • • Coil, Swing Tube Circuit Solenoid Valve	2
16	W-105572	• Cartridge, Solenoid Valve	1
17	W-105605	• • Coil	1
18	W-105579	• Valve, HP Limiter	1
19	W-103616	• Accumulator	1
20	71460	• Kit, Accumulator Charge (Optional Item) (See Group 80, Figure 02 for REF)	1
21	73171	• Bracket, Accumulator	A/R
22	W-105582	• Valve, Proportional Pilot	1
23	W-105606	• • Coil	1
24	W-105581	• Assembly, Pump Control Solenoid Valve	1
25	W-105576	• • Coil, Pump Control Solenoid Valve	2
26	W-104846	• Assembly, Pump Control Manifold	1
27	W-105570	• Cartridge, Relief Valve	1
28	W-105577	• Cartridge, Check Valve	1
29	W-105578	• Valve, Ball	1
30	W-104691	• Plug	4
31	801496	• Assembly, Suction Filter	1
32	801498	• • Element, Suction Filter	1
33		• • Gauge, Suction Filter	1
34	801871-003	• Plug	3
35	801026	• Gauge, Level / Temperature 10 Inch	1
36	80264-016	• Flange, Split	1
37	801508	• Adapter, 45	1
38	801526	• Adapter, STR	1

DASH (-) ITEM NOT ILLUSTRATED

REVISION:



TANK INSTALLATION

XT 36
PARTS
GROUP 30
FIGURE 01
PAGE 03

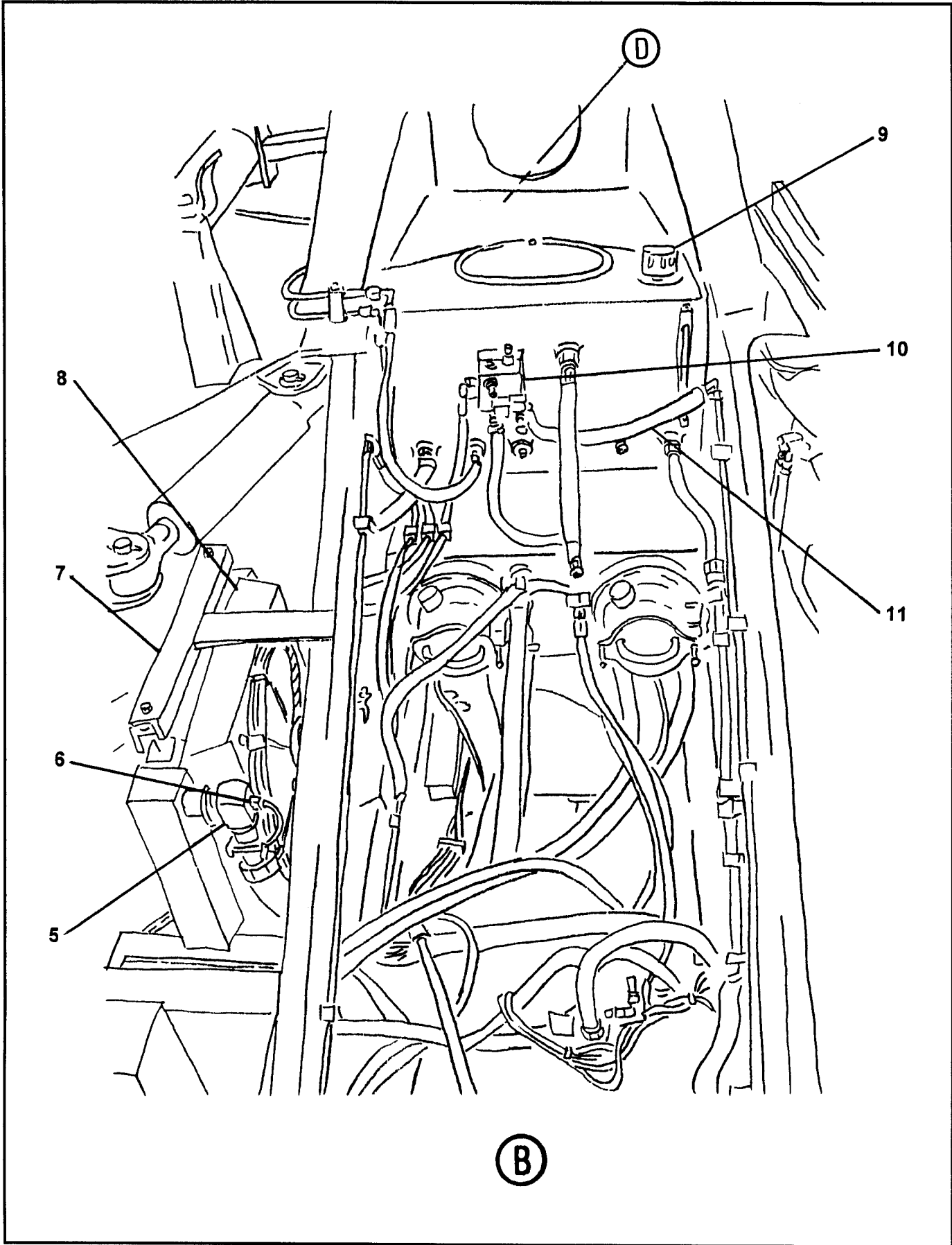

REVISION:

ITEM NO.	REED'S PARTS NO.	DESCRIPTION					QTY
		1	2	3	4	5	
-1	30-01	Installation, Tank (See Group 10, Figure 01 for NHA)					Ref
2	30-02	• Group, Water System (See Group 30, Figure 02 for DET)					1
3	W-105526	• Assembly, Boom High Pressure Filter					1
4	800446	• • Element, Boom High Pressure Filter					1
5	801925	• Elbow, Temperature Sensor					1
6	W-105568	• Sensor, 55 C Temperature					1
7	801814	• Channel, Oil Cooler Bracket					1
8	801868	• Assembly, Hydraulic Oil Cooler					1
9	801935	• Assembly, Hydraulic Tank (See Group 30, Figure 05 for DET)					1
10	802281	• Assembly, Oil Cooler Manifold (See Group 30, Figure 06 for DET)					1
11	801487-006	• Assembly, Tube					1
12	W-104847	• Assembly, Swing Tube Manifold					1
13	W-105573	• Assembly, Swing Tube Circuit Solenoid Valve					1
14	W-105581	• • Pilot, Solenoid Valve					1
15	W-105576	• • • Coil, Swing Tube Circuit Solenoid Valve					2
16	W-105572	• Cartridge, Solenoid Valve					1
17	W-105605	• • Coil					1
18	W-105579	• Valve, HP Limiter					1
19	W-103616	• Accumulator					1
20	71460	• Kit, Accumulator Charge (Optional Item) (See Group 80, Figure 02 for REF)					1
21	73171	• Bracket, Accumulator					A/R
22	W-105582	• Valve, Proportional Pilot					1
23	W-105606	• • Coil					1
24	W-105581	• Assembly, Pump Control Solenoid Valve					1
25	W-105576	• • Coil, Pump Control Solenoid Valve					2
26	W-104846	• Assembly, Pump Control Manifold					1
27	W-105570	• Cartridge, Relief Valve					1
28	W-105577	• Cartridge, Check Valve					1
29	W-105578	• Valve, Ball					1
30	W-104691	• Plug					4
31	801496	• Assembly, Suction Filter					1
32	801498	• • Element, Suction Filter					1
33		• • Gauge, Suction Filter					1
34	801871-003	• Plug					3
35	801026	• Gauge, Level / Temperature 10 Inch					1
36	80264-016	• Flange, Split					1
37	801508	• Adapter, 45					1
38	801526	• Adapter, STR					1

DASH (-) ITEM NOT ILLUSTRATED

REVISION:

TANK INSTALLATION

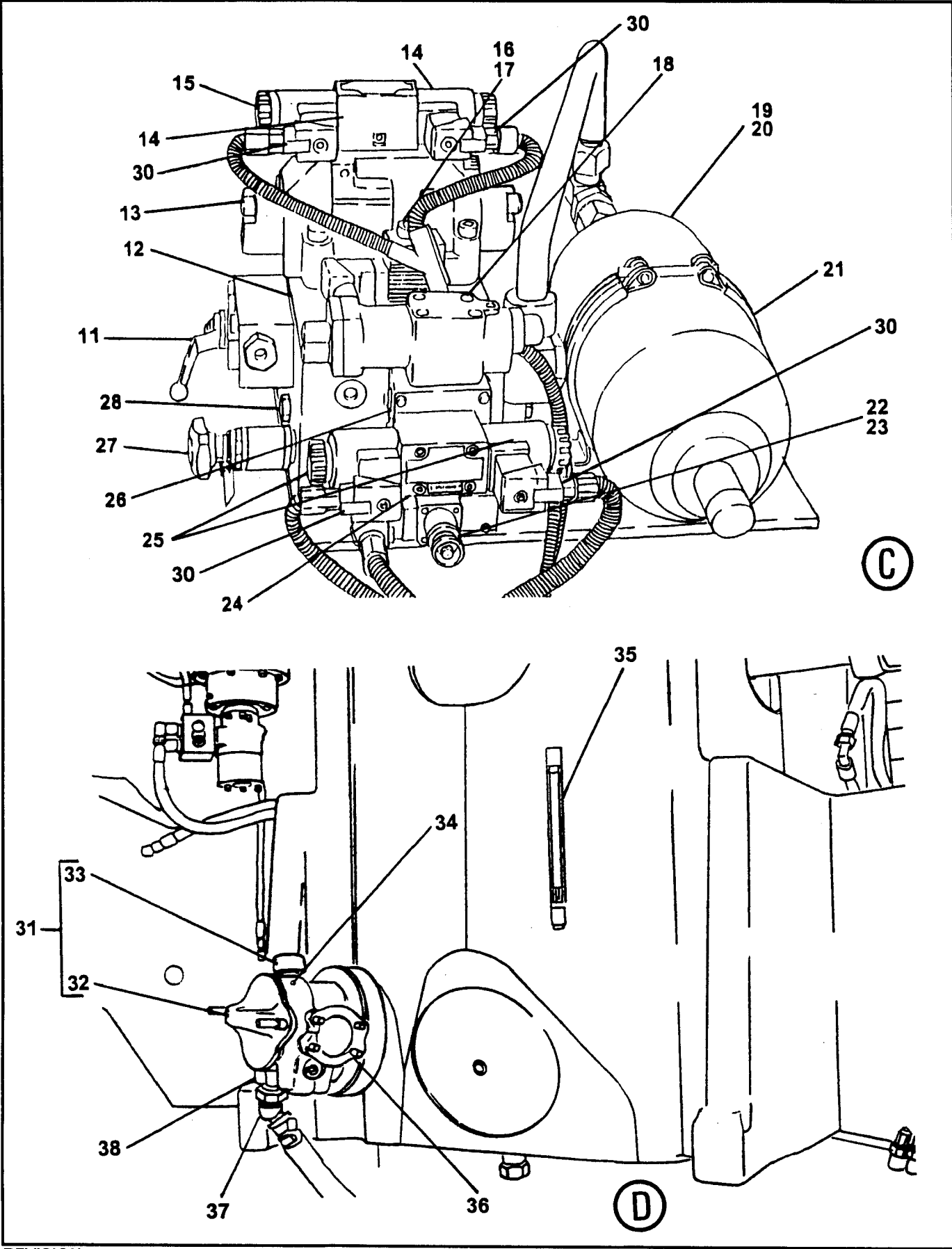

REVISION:

ITEM NO.	REED'S PARTS NO.	DESCRIPTION					QTY
		1	2	3	4	5	
-1	30-01	Installation, Tank (See Group 10, Figure 01 for NHA)					Ref
2	30-02	• Group, Water System (See Group 30, Figure 02 for DET)					1
3	W-105526	• Assembly, Boom High Pressure Filter					1
4	800446	• • Element, Boom High Pressure Filter					1
5	801925	• Elbow, Temperature Sensor					1
6	W-105568	• Sensor, 55 C Temperature					1
7	801814	• Channel, Oil Cooler Bracket					1
8	801868	• Assembly, Hydraulic Oil Cooler					1
9	801935	• Assembly, Hydraulic Tank (See Group 30, Figure 05 for DET)					1
10	802281	• Assembly, Oil Cooler Manifold (See Group 30, Figure 06 for DET)					1
11	801487-006	• Assembly, Tube					1
12	W-104847	• Assembly, Swing Tube Manifold					1
13	W-105573	• Assembly, Swing Tube Circuit Solenoid Valve					1
14	W-105581	• • Pilot, Solenoid Valve					1
15	W-105576	• • • Coil, Swing Tube Circuit Solenoid Valve					2
16	W-105572	• Cartridge, Solenoid Valve					1
17	W-105605	• • Coil					1
18	W-105579	• Valve, HP Limiter					1
19	W-103616	• Accumulator					1
20	71460	• Kit, Accumulator Charge (Optional Item) (See Group 80, Figure 02 for REF)					1
21	73171	• Bracket, Accumulator					A/R
22	W-105582	• Valve, Proportional Pilot					1
23	W-105606	• • Coil					1
24	W-105581	• Assembly, Pump Control Solenoid Valve					1
25	W-105576	• • Coil, Pump Control Solenoid Valve					2
26	W-104846	• Assembly, Pump Control Manifold					1
27	W-105570	• Cartridge, Relief Valve					1
28	W-105577	• Cartridge, Check Valve					1
29	W-105578	• Valve, Ball					1
30	W-104691	• Plug					4
31	801496	• Assembly, Suction Filter					1
32	801498	• • Element, Suction Filter					1
33		• • Gauge, Suction Filter					1
34	801871-003	• Plug					3
35	801026	• Gauge, Level / Temperature 10 Inch					1
36	80264-016	• Flange, Split					1
37	801508	• Adapter, 45					1
38	801526	• Adapter, STR					1

DASH (-) ITEM NOT ILLUSTRATED

REVISION:



WATER SYSTEM GROUP

XT 36
PARTS
GROUP 30
FIGURE 02
PAGE 01

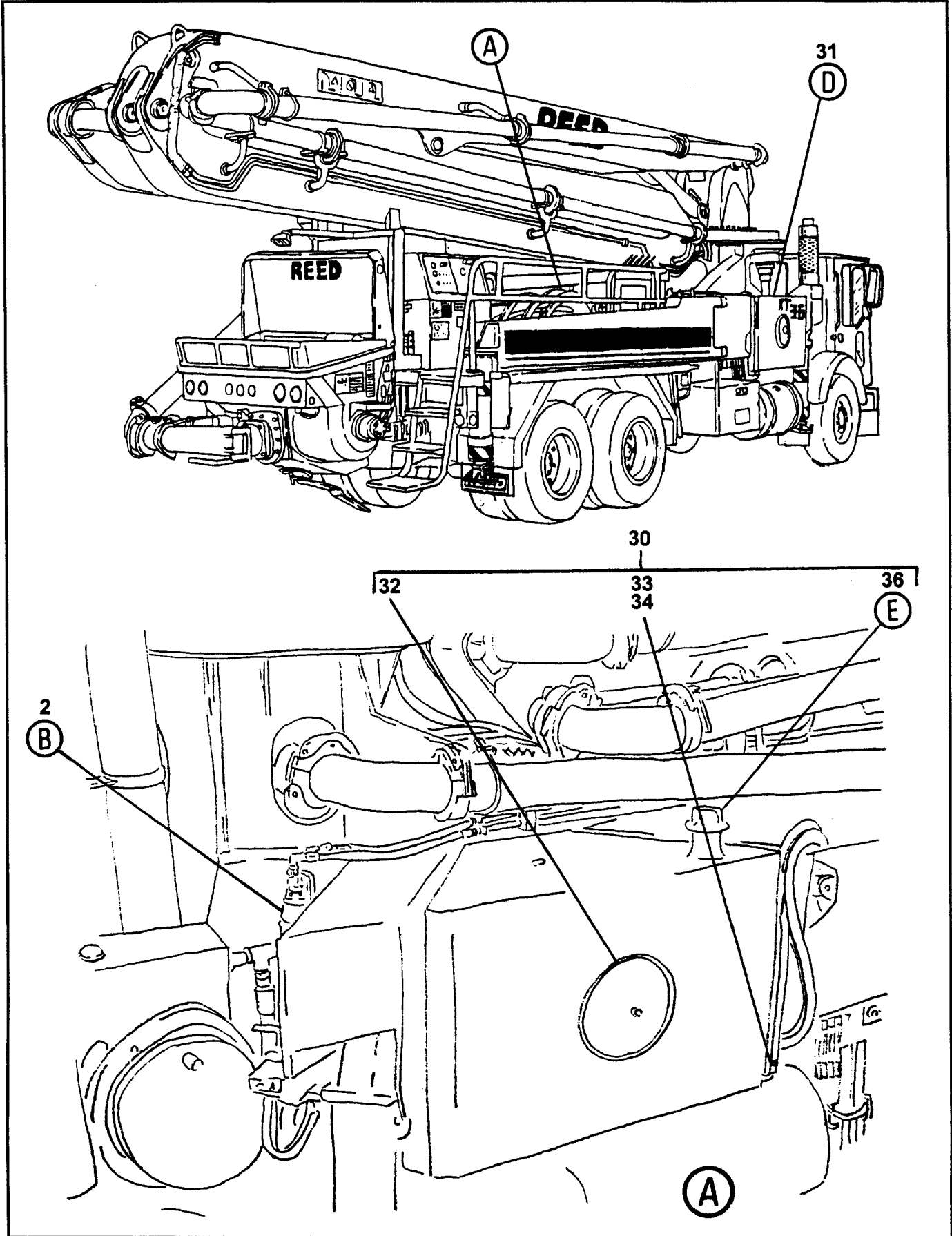

REVISION:

ITEM NO.	REED'S PARTS NO.	DESCRIPTION					QTY
		1	2	3	4	5	
-1	30-02	Group, Water System (See Group 30, Figure 01 for NHA)					Ref
2	802247	• Kit, Water Pump Retro-Fit					1
3	801740	• • Plate, Water Pump					1
4	85663-008	• • Assembly, Hose					1
5	801896-004	• • Fitting, STR					1
6	801487-012	• • Assembly, Hose					1
7	801896-003	• • Fitting, STR					1
8	78128	• • Valve, Relief					1
9		• • Tee					1
10	802295	• • Adapter, Water pump Flange					1
11	802294	• • Adapter, Water pump Flange					1
12	801899-003	• • Union, Swivel					2
13	801877-004	• • Union, Tube					2
14	801888-004	• • Elbow, Swivel					2
15	801486-001	• • Assembly, Hose					2
16	802325	• • Plate, Water Pump Cover					1
17	B-323030	• • Assembly, Water Pump And Drive					1
18	W-101126	• • • Assembly, Wash Water Pump (See Group 30, Figure 03 for DET)					1
19	B-323019	• • • Coupling					1
20	B-323016	• • • Flange					1
21	W-105929	• • • Screw, M8					4
22	W-100235	• • • Washer, Spring					8
23	W-105922	• • • Assembly, Water Pump Motor (See Group 30, Figure 04 for DET)					1
24	W-102916	• • • Coupling, Splined					1
25	W-102915	• • • Support, Belt Pulley					1
26	W-105930	• • • Screw, M8					4
27	W-103673	• • • Bolt, M6 Alien					1
28	W-105931	• • • Ring, Locking					1
29	B-323021	• • • Washer					1
30	801959	• Assembly, LH Water Tank					1
31	801960	• Assembly, RH Water Tank					1
32	801023	• • Kit, Endcover					1
33	801978	• • Tubing, Clear 28 Inch					1
34	802289	• • Clamp, Hose					2
-35	W-104496	• • Buffer, Rubber					4
36	801708	• • Weldment, Water tank					1
37		• • • Screw, Socket head Cap					2
38	801682	• • • Weldment, Water Tank cap					1
39	30214	• • • Chain, 12 inch					1

DASH (-) ITEM NOT ILLUSTRATED

REVISION:



WATER SYSTEM GROUP

XT 36
PARTS
GROUP 30
FIGURE 02
PAGE 03

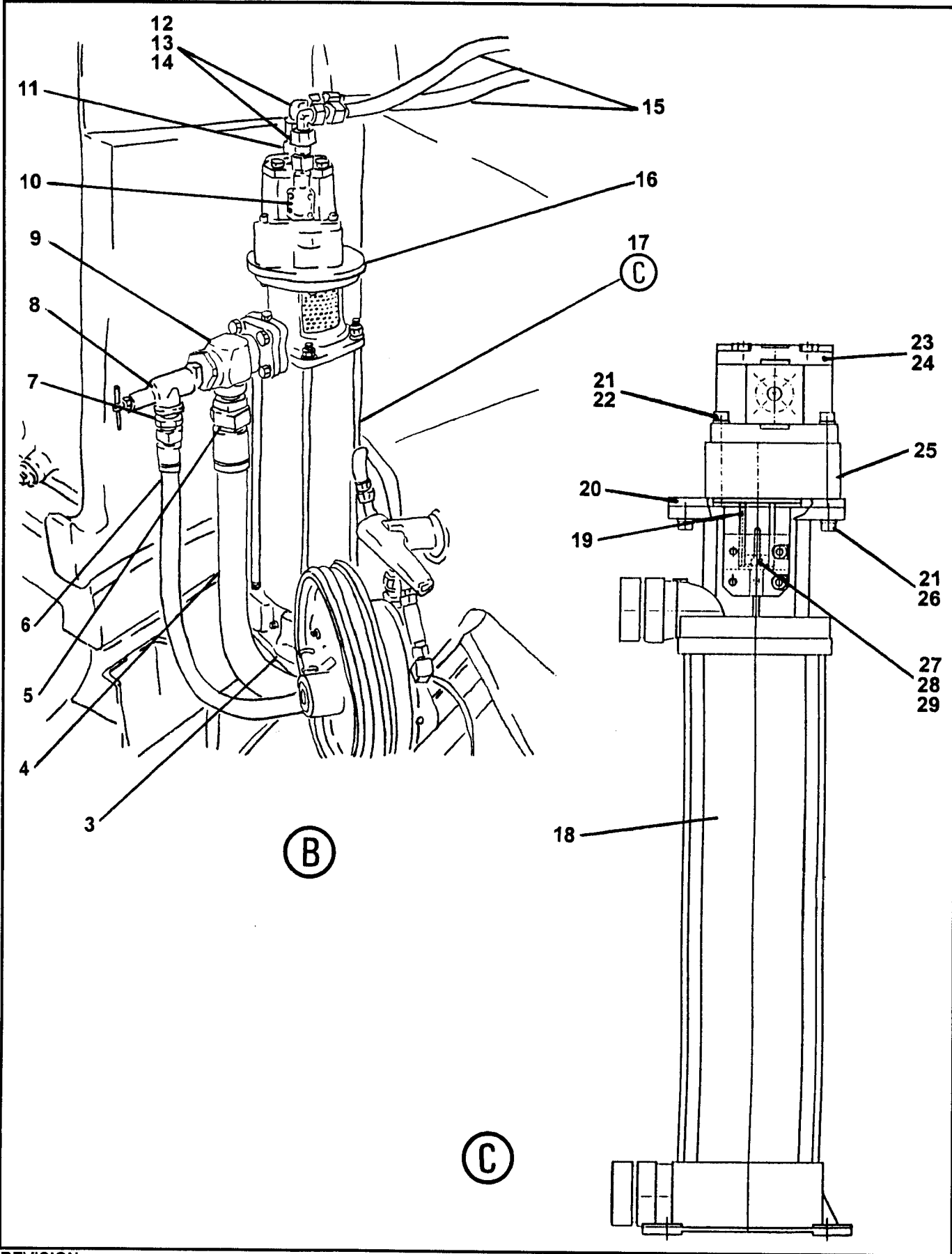

REVISION:

ITEM NO.	REED'S PARTS NO.	DESCRIPTION					QTY
		1	2	3	4	5	
-1	30-02	Group, Water System (See Group 30, Figure 01 for NHA)					Ref
2	802247	• Kit, Water Pump Retro-Fit					1
3	801740	• • Plate, Water Pump					1
4	85663-008	• • Assembly, Hose					1
5	801896-004	• • Fitting, STR					1
6	801487-012	• • Assembly, Hose					1
7	801896-003	• • Fitting, STR					1
8	78128	• • Valve, Relief					1
9		• • Tee					1
10	802295	• • Adapter, Water pump Flange					1
11	802294	• • Adapter, Water pump Flange					1
12	801899-003	• • Union, Swivel					2
13	801877-004	• • Union, Tube					2
14	801888-004	• • Elbow, Swivel					2
15	801486-001	• • Assembly, Hose					2
16	802325	• • Plate, Water Pump Cover					1
17	B-323030	• • Assembly, Water Pump And Drive					1
18	W-101126	• • • Assembly, Wash Water Pump (See Group 30, Figure 03 for DET)					1
19	B-323019	• • • Coupling					1
20	B-323016	• • • Flange					1
21	W-105929	• • • Screw, M8					4
22	W-100235	• • • Washer, Spring					8
23	W-105922	• • • Assembly, Water Pump Motor (See Group 30, Figure 04 for DET)					1
24	W-102916	• • • Coupling, Splined					1
25	W-102915	• • • Support, Belt Pulley					1
26	W-105930	• • • Screw, M8					4
27	W-103673	• • • Bolt, M6 Alien					1
28	W-105931	• • • Ring, Locking					1
29	B-323021	• • • Washer					1
30	801959	• Assembly, LH Water Tank					1
31	801960	• Assembly, RH Water Tank					1
32	801023	• • Kit, Endcover					1
33	801978	• • Tubing, Clear 28 Inch					1
34	802289	• • Clamp, Hose					2
-35	W-104496	• • Buffer, Rubber					4
36	801708	• • Weldment, Water tank					1
37		• • • Screw, Socket head Cap					2
38	801682	• • • Weldment, Water Tank cap					1
39	30214	• • • Chain, 12 inch					1

DASH (-) ITEM NOT ILLUSTRATED

REVISION:



WATER SYSTEM GROUP

XT 36
PARTS
GROUP 30
FIGURE 02
PAGE 05

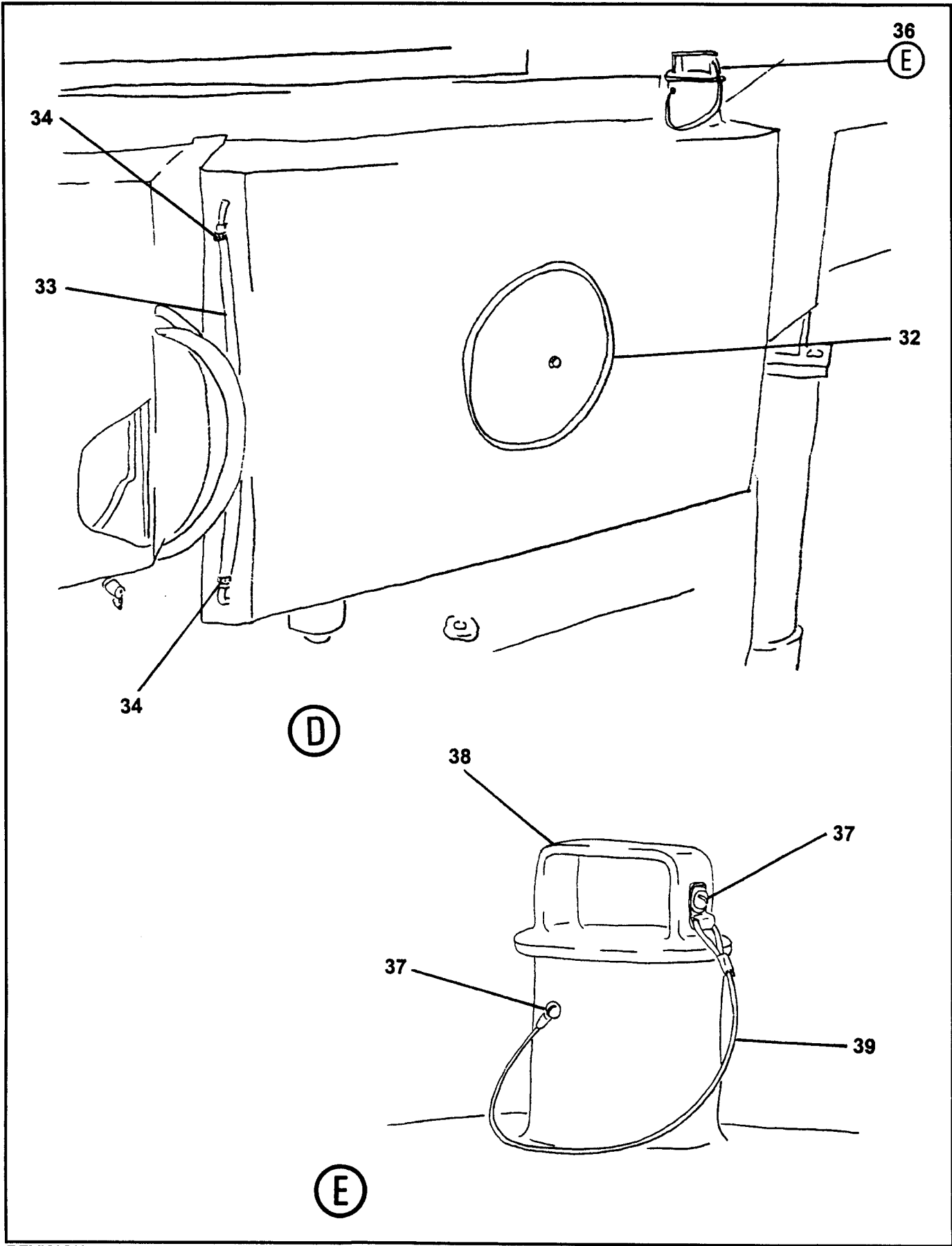

REVISION:



WATER SYSTEM GROUP

XT 36
PARTS
 GROUP 30
 FIGURE 02
 PAGE 06

ITEM NO.	REED'S PARTS NO.	DESCRIPTION					QTY
		1	2	3	4	5	
-1	30-02	Group, Water System (See Group 30, Figure 01 for NHA)					Ref
2	802247	• Kit, Water Pump Retro-Fit					1
3	801740	• • Plate, Water Pump					1
4	85663-008	• • Assembly, Hose					1
5	801896-004	• • Fitting, STR					1
6	801487-012	• • Assembly, Hose					1
7	801896-003	• • Fitting, STR					1
8	78128	• • Valve, Relief					1
9		• • Tee					1
10	802295	• • Adapter, Water pump Flange					1
11	802294	• • Adapter, Water pump Flange					1
12	801899-003	• • Union, Swivel					2
13	801877-004	• • Union, Tube					2
14	801888-004	• • Elbow, Swivel					2
15	801486-001	• • Assembly, Hose					2
16	802325	• • Plate, Water Pump Cover					1
17	B-323030	• • Assembly, Water Pump And Drive					1
18	W-101126	• • • Assembly, Wash Water Pump (See Group 30, Figure 03 for DET)					1
19	B-323019	• • • Coupling					1
20	B-323016	• • • Flange					1
21	W-105929	• • • Screw, M8					4
22	W-100235	• • • Washer, Spring					8
23	W-105922	• • • Assembly, Water Pump Motor (See Group 30, Figure 04 for DET)					1
24	W-102916	• • • Coupling, Splined					1
25	W-102915	• • • Support, Belt Pulley					1
26	W-105930	• • • Screw, M8					4
27	W-103673	• • • Bolt, M6 Alien					1
28	W-105931	• • • Ring, Locking					1
29	B-323021	• • • Washer					1
30	801959	• Assembly, LH Water Tank					1
31	801960	• Assembly, RH Water Tank					1
32	801023	• • Kit, Endcover					1
33	801978	• • Tubing, Clear 28 Inch					1
34	802289	• • Clamp, Hose					2
-35	W-104496	• • Buffer, Rubber					4
36	801708	• • Weldment, Water tank					1
37		• • • Screw, Socket head Cap					2
38	801682	• • • Weldment, Water Tank cap					1
39	30214	• • • Chain, 12 inch					1

DASH (-) ITEM NOT ILLUSTRATED

REVISION:



WASH WATER PUMP ASSEMBLY

XT 36
PARTS
GROUP 30
FIGURE 03
PAGE 01

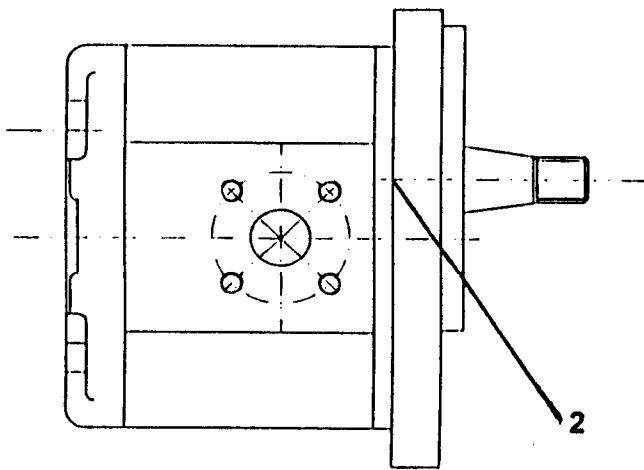

REVISION:

ITEM NO.	REED'S PARTS NO.	DESCRIPTION					QTY
		1	2	3	4	5	
-1	W-105922	Assembly, Wash Water Pump (See Group 30, Figure 02 for NHA)					Ref
2	W-106044	• Kit, Seal					1

DASH (-) ITEM NOT ILLUSTRATED



WATER PUMP MOTOR ASSEMBLY

XT 36
PARTS
GROUP 30
FIGURE 04
PAGE 01

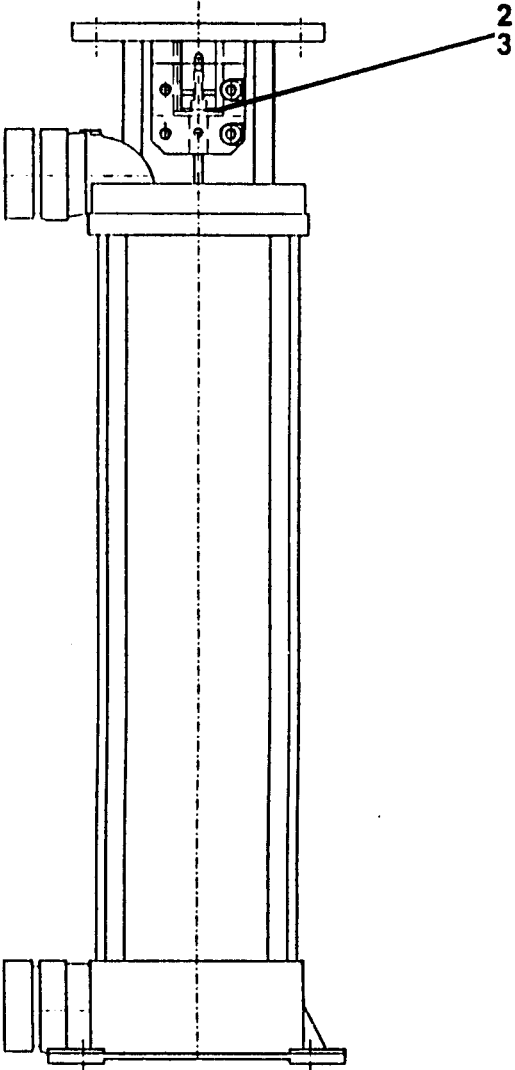

REVISION:



WATER PUMP MOTOR ASSEMBLY

XT 36
PARTS
GROUP 30
FIGURE 04
PAGE 02

ITEM NO.	REED'S PARTS NO.	1 2 3 4 5	DESCRIPTION	QTY
-1	W-101126		Assembly, Water Pump Motor (See Group 30, Figure 02 for NHA)	Ref
2	W-105988		• Coupling	1
3	W-106043		• Kit, Seal	1

DASH (-) ITEM NOT ILLUSTRATED



HYDRAULIC TANK ASSEMBLY

XT 36
PARTS
GROUP 30
FIGURE 05
PAGE 01

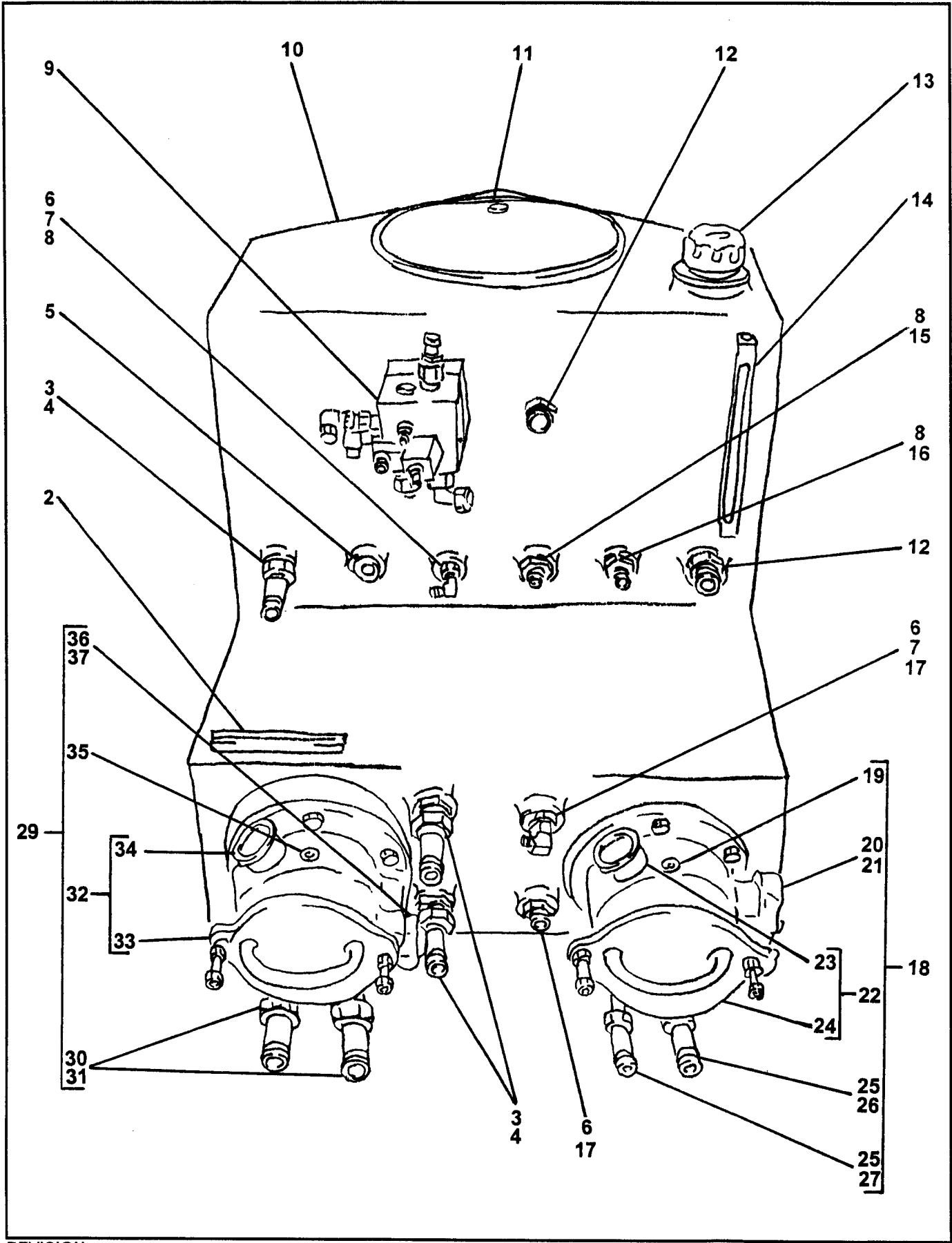

REVISION:

ITEM NO.	REED'S PARTS NO.	DESCRIPTION					QTY
		1	2	3	4	5	
-1	801935	Assembly, Hydraulic Tank (See Group 30, Figure 01 for NHA)					Ref
2	801171-007	• C-Rail, 6.5 Inch					1
3	W-105170	• Adapter, STR					3
4		• Fitting, STR					3
5	801871-006	• Plug					1
6	801888-003	• Elbow, Swivel					2
7	801873-006	• Adapter, STR					2
8	801895-001	• Reducer					3
9	802281	• Assembly, Oil Cooler Manifold (See Group 30, Figure 06 for DET)					1
10	801700	• Weldment, Hydraulic Tank					1
11	801023	• • Kit, End Cover					1
12	801872-008	• Adapter, STR					2
13	74508	• Breather, Filler					1
14	801026	• Gauge, Level / Temperature 10 Inch					1
15	801873-008	• Adapter, STR					1
16	801873-010	• Adapter, STR					1
17	801895-001	• Reducer					2
18	802370	• Assembly, RH Suction Filter					1
19	801871-003	• • Plug					3
20	801937	• • Plug, Flange					1
21	86264-016	• • Flange, Split					1
22	801496	• • Assembly, Suction Filter					1
23		• • • Gauge, Suction Filter					1
24	801498	• • • Element, Suction Filter					1
25	801526	• • Adapter, STR					2
26	801506	• • Adapter, 90					1
27	801509	• • Adapter, 90					1
-28	W-104496	• Buffer, Rubber					4
29	802371	• Assembly, LH Suction Filter					1
30	801526	• • Adapter, STR					2
31	801506	• • Adapter, 90					2
32	801496	• • Assembly, Suction Filter					1
33	801498	• • • Element, Suction Filter					1
34		• • • Gauge, Suction Filter					1
35	801871-003	• • Plug					3
36	801937	• • Plug, Flange					1
37	86264-016	• • Flange, Split					1

DASH (-) ITEM NOT ILLUSTRATED



OIL COOLER MANIFOLD ASSEMBLY

XT 36
PARTS
GROUP 30
FIGURE 06
PAGE 01

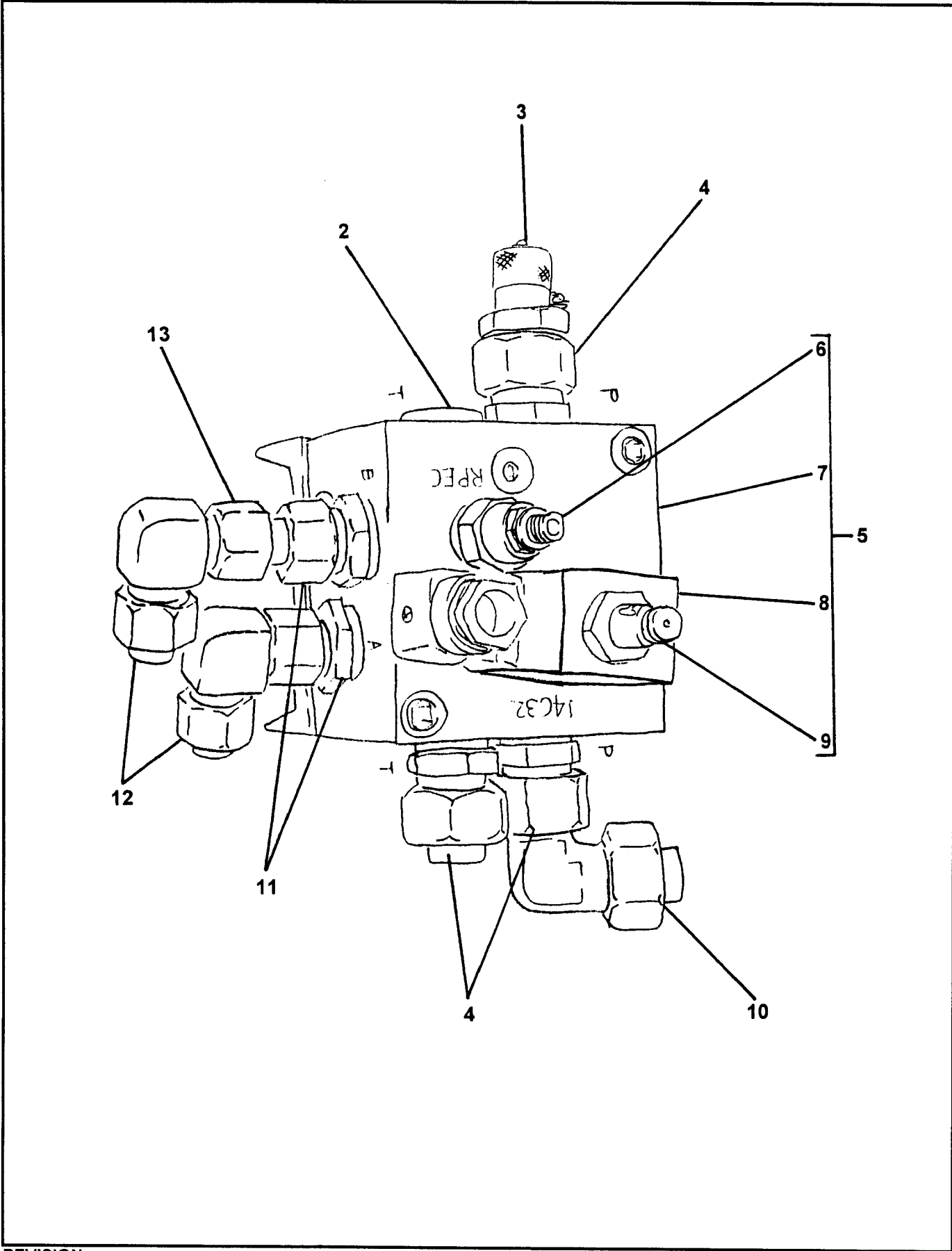

REVISION:



OIL COOLER MANIFOLD ASSEMBLY

XT 36
PARTS
GROUP 30
FIGURE 06
PAGE 02

ITEM NO.	REED'S PARTS NO.	DESCRIPTION					QTY
		1	2	3	4	5	
-1	802281	Assembly, Oil Cooler Manifold (See Group 30, Figure 01 and Figure 05 for NHA)					Ref
2	801871-004	• Plug					1
3	W-104831	• Fitting, L15 Gauge					1
4	801873-010	• Adapter, STR					3
5	801629	• Manifold, Oil Cooler					1
6	801837	• • Cartridge, Relief					1
7		• • Block, Manifold					1
8	801839	• • Coil, Manifold					1
9	801838	• • Cartridge, Manifold Solenoid					1
10	801888-005	• Elbow, Swivel					1
11	801873-006	• Adapter, STR					2
12	801888-002	• Elbow, Swivel					2
13	801899-002	• Union, Swivel					1

DASH (-) ITEM NOT ILLUSTRATED

REVISION:



**MODEL XT 36 TRUCK MOUNTED
CONCRETE BOOM PUMP
ILLUSTRATED PARTS MANUAL**

**XT 36
PARTS
GROUP 30
FIGURE 07
PAGE 01**

THIS PAGE INTENTIONALLY LEFT BLANK.

REVISION:

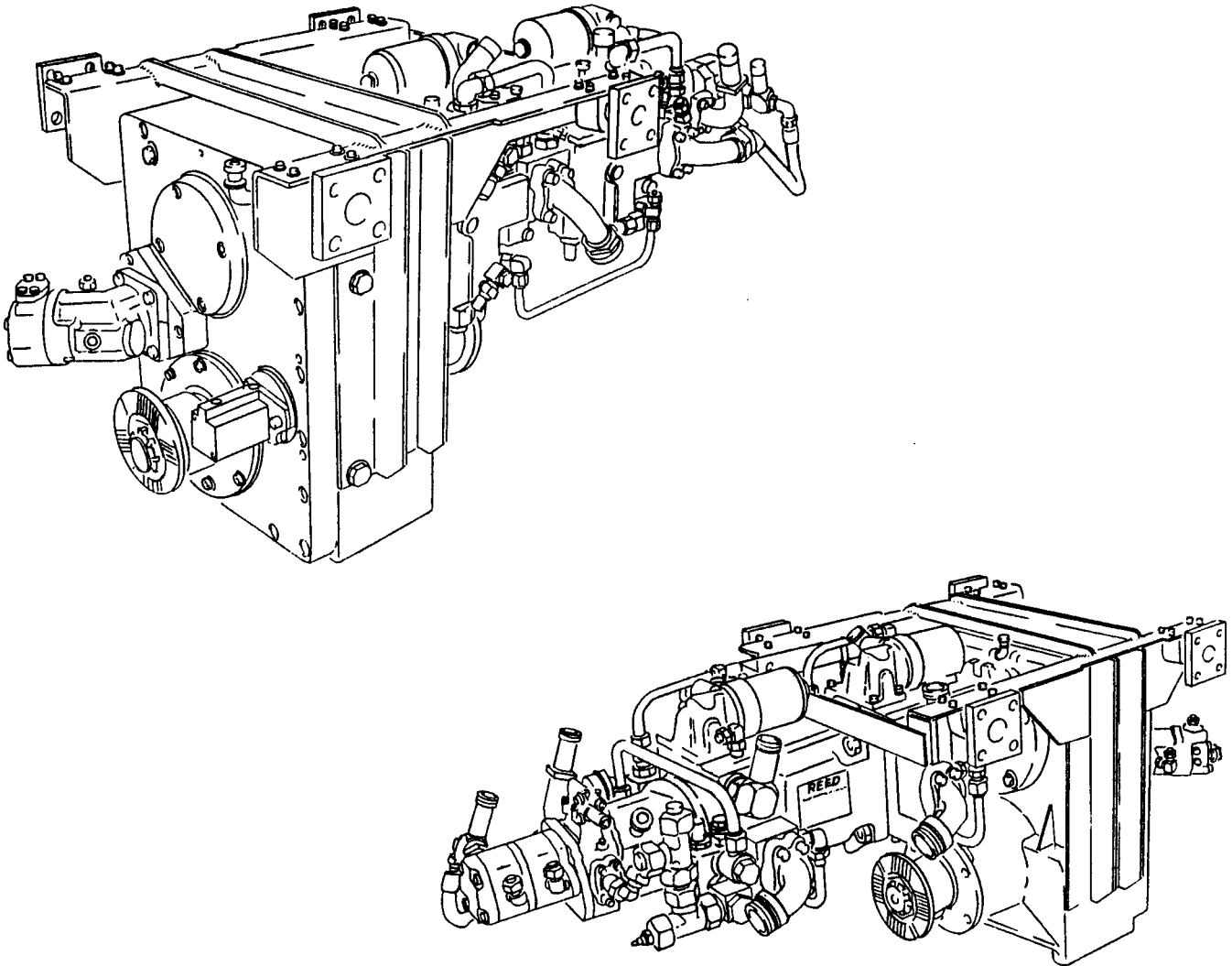

REED TRUCK MOUNTED CONCRETE BOOM PUMP MODEL XT 36 ILLUSTRATED PARTS MANUAL GROUP 40 POWER TRAIN INSTALLATION CONTAINS THE FOLLOWING FIGURES:

- | | |
|------------------|---------------------------------|
| FIGURE 00 | TABLE OF CONTENTS |
| FIGURE 01 | POWER TRAIN INSTALLATION |
| FIGURE 02 | GEAR PUMP ASSEMBLY |
| FIGURE 03 | PTO GEARBOX ASSEMBLY |



POWER TRAIN INSTALLATION

XT 36
PARTS
GROUP 40
FIGURE 01
PAGE 01

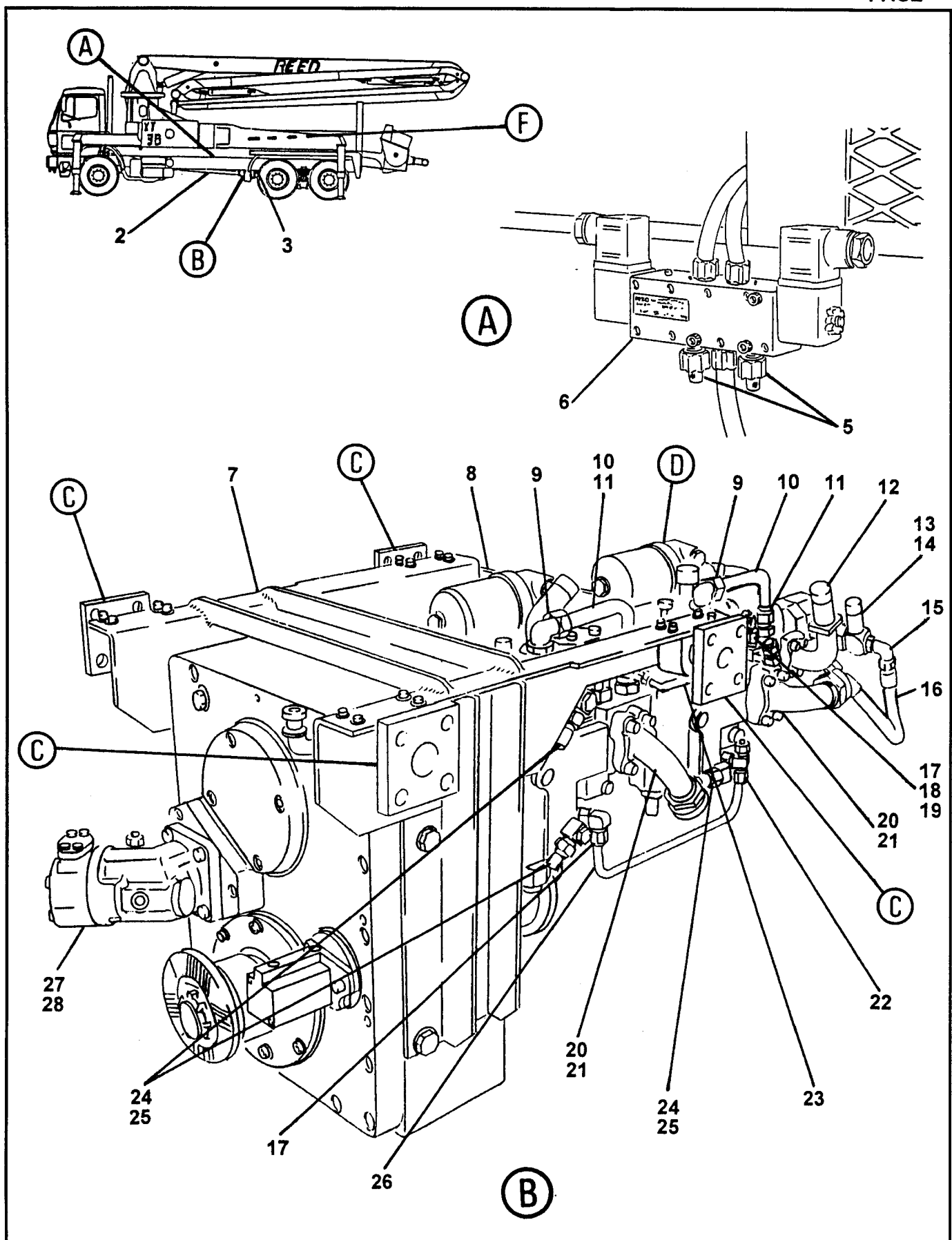

REVISION:



POWER TRAIN INSTALLATION

XT 36
PARTS
GROUP 40
FIGURE 01
PAGE 02

ITEM NO.	REED'S PARTS NO.	DESCRIPTION					QTY
		1	2	3	4	5	
-1	40-04	Installation, Power Train (See Group 10, Figure 01 for NHA)					Ref
2	801480	• Shaft, Front Drive					1
3	801481	• Shaft, Rear Drive					1
-4	800610	• Installation, XT 36 PTO Gearbox					1
5	800064	• • Muffler, Air Valve					2
6	800063	• • Valve, Air					1
7	801788	• • Mount, PTO Gearbox with Rexroth					1
8	801792	• • Brace, PTO Mount					1
9	801888-005	• • Swivel, Elbow					7
10	801793	• • Assembly, Tube					2
11		• • Adapter, STR					2
12	801512	• • Adapter, 90L					1
13	801510	• • Adapter, 90L					1
14	801516	• • Adapter, STR					1
15	801888-014	• • Swivel, Elbow					3
16	801486-005	• • Assembly, Hose					1
17	801888-003	• • Swivel, Elbow					3
18	801890-003	• • Swivel, Tee					1
19	W-105076	• • Port, Pressure Test					3
20	801778	• • Manifold, Pump					2
21	801503	• • Adapter, 90L					4
22	801889-003	• • Swivel, Tee					1
23	802339	• • Assembly, Tube					1
24	801874-003	• • Banjo					4
25	W-104831	• • Port, Pressure Test					4
26	801797	• • Assembly, Tube					1
27	W-103623	• • Assembly, Boom Pump					1
28	W-105925	• • • Seal, Boom Pump Shaft					1

DASH (-) ITEM NOT ILLUSTRATED

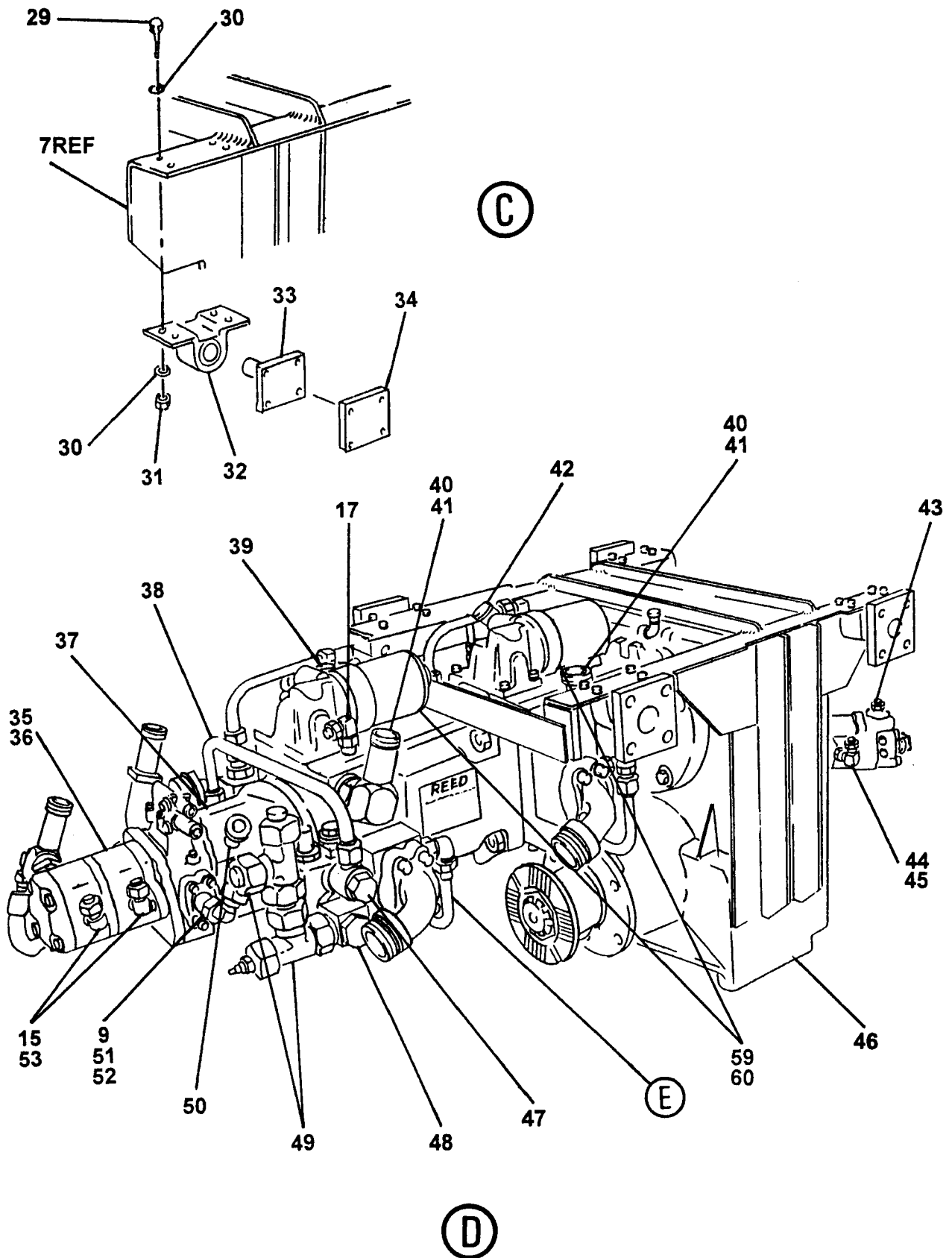



POWER TRAIN INSTALLATION

XT 36
PARTS
GROUP 40
FIGURE 01
PAGE 04

ITEM NO.	REED'S PARTS NO.	1 2 3 4 5	DESCRIPTION	QTY
29		• •	Bolt, Hex	16
30		• •	Washer	32
31		• •	Nut, Lock	16
32	W-103414	• •	Buffer, Rubber	4
33	800125	• •	Axle, PTO Mount	4
34	800128	• •	Plate, PTO Axle Mount	4
35	801684	• •	Assembly, 4/4CC Gear Pump	1
36	800061	• • •	O-Ring, Gear Pump	1
37	W-105650	• •	Assembly, Gear Pump (See Group 40, Figure 03 for DET)	1
38	801796	• •	Assembly, Tube	1
39	W-105170	• •	Adapter, STR	1
40	801506	• •	Adapter, 90L	2
41	801526	• •	Adapter, STR	2
42	W-105169	• •	Adapter, 45	1
43	801873-011	• •	Adapter	1
44	801524	• •	Adapter, STR	1
45	801509	• •	Adapter, 90L	1
46	802242	• •	Assembly, PTO Gear Box (See Group 40, Figure 04 for DET)	1
47	801527	• •	Adapter, STR	1
48		• •	Banjo	1
49	801890-006	• •	Swivel, Tee	2
50	801876-005	• •	Adapter, STR	1
51	86264-002	• •	Flange, Split	1
52	W-105075	• •	Adapter, STR	1
53	801876-003	• •	Adapter	2
54	801057	• •	Manifold, Pump	2
55	801794	• •	Assembly, Tube	1
56	801795	• •	Assembly, Tube	1
57	W-105567	• •	Sensor, Thermal	1
58	801927	• •	Adapter, Thermal Sensor	1
59	801499	• •	Filter, A4VG125 Charge Pump	2
60	801500	• • •	Element, A4VG125 Charge Pump Filter	2

DASH (-) ITEM NOT ILLUSTRATED

POWER TRAIN INSTALLATION

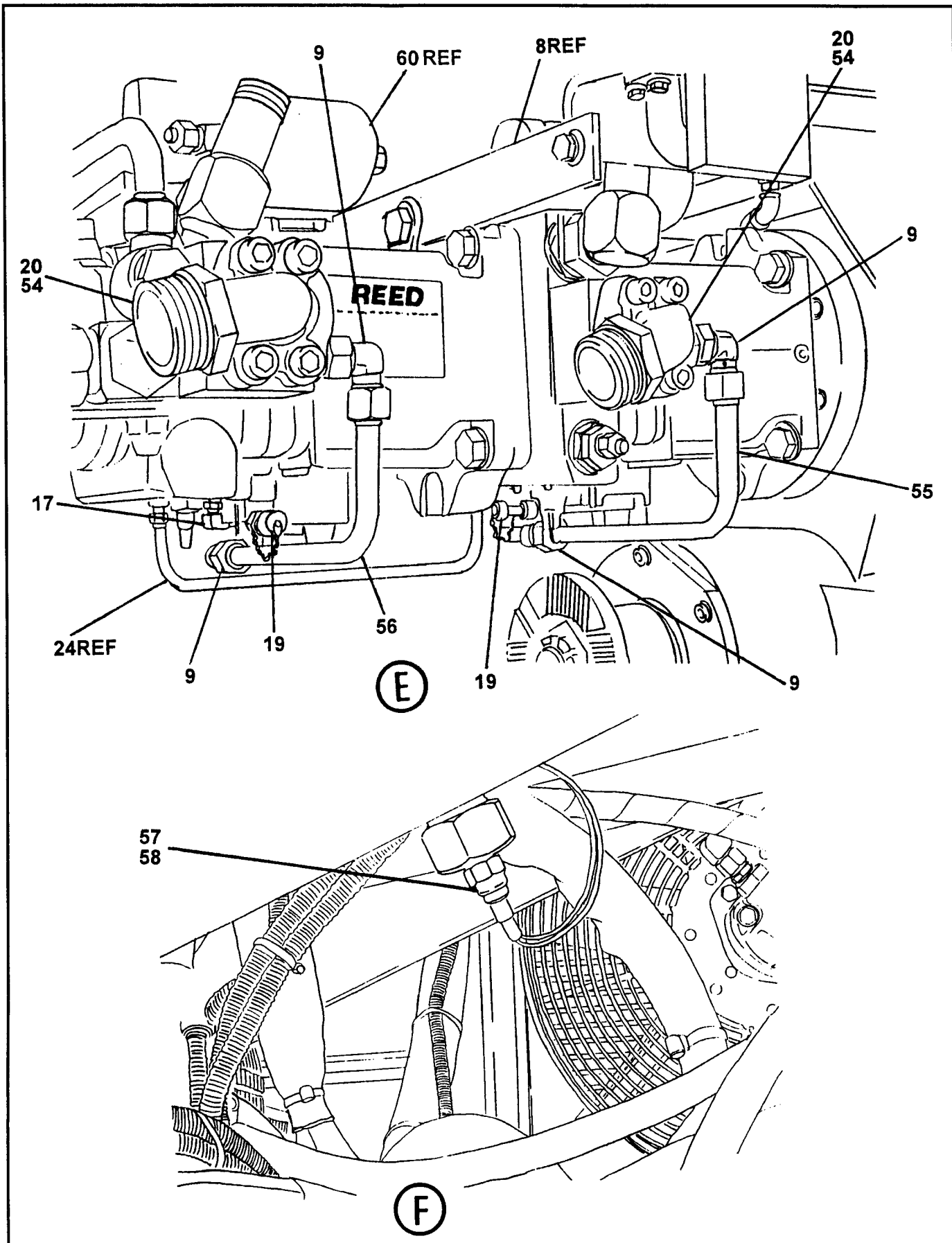



POWER TRAIN INSTALLATION

XT 36
PARTS
GROUP 40
FIGURE 01
PAGE 06

ITEM NO.	REED'S PARTS NO.	DESCRIPTION					QTY
		1	2	3	4	5	
29		• •	Bolt, Hex				16
30		• •	Washer				32
31		• •	Nut, Lock				16
32	W-103414	• •	Buffer, Rubber				4
33	800125	• •	Axle, PTO Mount				4
34	800128	• •	Plate, PTO Axle Mount				4
35	801684	• •	Assembly, 4/4CC Pump				1
36	800061	• • •	O-Ring, 4/4CC Pump				1
37	W-105650	• •	Assembly, Gear Pump (See Group 40, Figure 02 for DET)				1
38	801796	• •	Assembly, Tube				1
39	W-105170	• •	Adapter, STR				1
40	801506	• •	Adapter, 90L				2
41	801526	• •	Adapter, STR				2
42	W-105169	• •	Adapter, 45				1
43	801873-011	• •	Adapter				1
44	801524	• •	Adapter, STR				1
45	801509	• •	Adapter, 90L				1
46	802242	• •	Assembly, PTO Gear Box (See Group 40, Figure 03 for DET)				1
47	801527	• •	Adapter, STR				1
48		• •	Banjo				1
49	801890-006	• •	Swivel, Tee				2
50	801876-005	• •	Adapter, STR				1
51	86264-002	• •	Flange, Split				1
52	W-105075	• •	Adapter, STR				1
53	801876-003	• •	Adapter				2
54	801057	• •	Manifold, Pump				2
55	801794	• •	Assembly, Tube				1
56	801795	• •	Assembly, Tube				1
57	W-105567	• •	Sensor, Thermal				1
58	801927	• •	Adapter, Thermal Sensor				1
59	801499	• •	Filter, A4VG125 Charge Pump				2
60	801500	• • •	Element, A4VG125 Charge Pump Filter				2

DASH (-) ITEM NOT ILLUSTRATED



GEAR PUMP ASSEMBLY

XT 36
PARTS
GROUP 40
FIGURE 02
PAGE 01

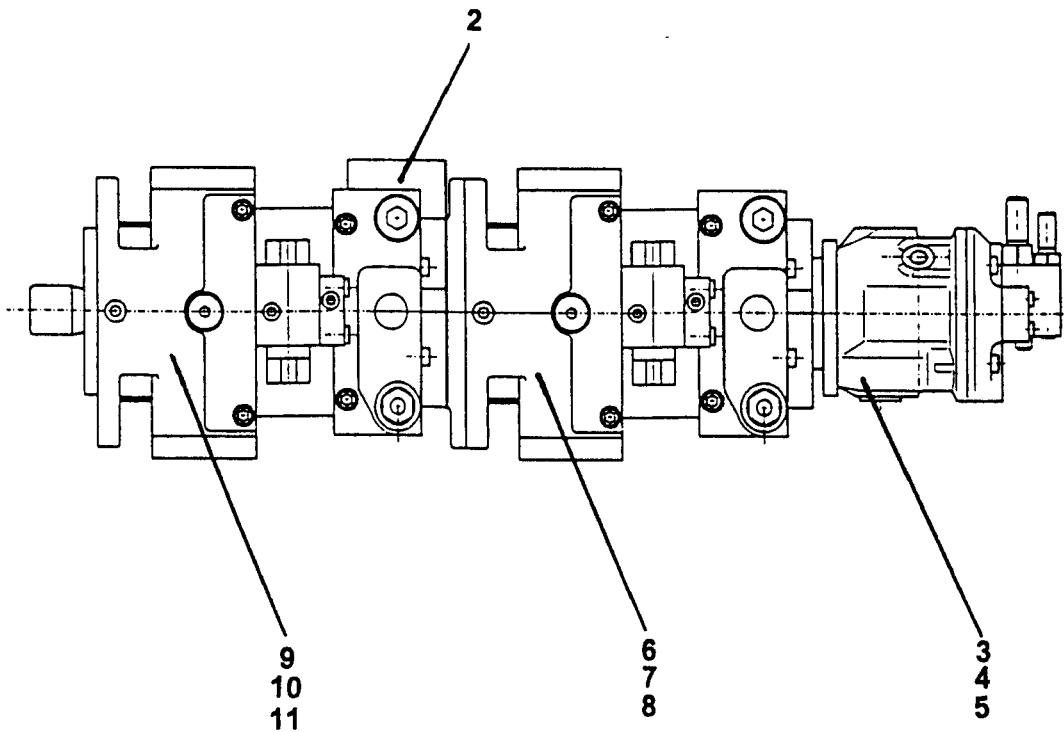

REVISION:



GEAR PUMP ASSEMBLY

XT 36
PARTS
GROUP 40
FIGURE 02
PAGE 02

ITEM NO.	REED'S PARTS NO.	DESCRIPTION					QTY
		1	2	3	4	5	
-1	W-105650	Assembly, Gear Pump (See Group 40, Figure 01 for NHA)					1
2	W-104949	• Valve, Flushing					1
3	W-105651	• Assembly, A10VO28 Gear Pump					1
4	W-105789	• • Kit, A10VO28 Gear Pump Seal					1
5	W-105001	• • Seal, Shaft					1
6	W-105592	• Assembly, A4VG125 Gear Pump					1
7	W-105787	• • Kit, A4VG125Gear Pump Seal					1
8	W-105788	• • Seal, Shaft					1
9	W-105591	• Assembly, A4VG125 Gear Pump					1
10	W-105785	• • Kit, A4VG125Gear Pump Seal					1
11	W-105786	• • Seal, Shaft					1

DASH (-) ITEM NOT ILLUSTRATED

REED**PTO GEAR BOX ASSEMBLY****XT 36**
PARTS
GROUP 40
FIGURE 03
PAGE 01

ITEM NO.	REED'S PARTS NO.	DESCRIPTION					QTY
		1	2	3	4	5	
-1	802242	Assembly, PTO Gear Box (See Group 40, Figure 01 for NHA)					1
10	802160	• Cylinder, PTO Shift					1
20	802161	• Adapter, Shaft					1
25	802162	• Adapter, Shaft					1
30	802163	• Cap, Packing Ring					2
35	802164	• Flange, Mounting					1
40	802165	• Flange, Mounting					1
50	802166	• Cover					1
55	802167	• Flange, Mounting					1
60	802168	• Gear, Coupling					1
70	802169	• Gear					1
80	802170	• Gear					1
90	802171	• Gear					1
100	802172	• Shaft, Toothed					1
110	802173	• Shaft, Coupling					1
120	802174	• Shaft, Toothed					1
130	802175	• Shaft, Splined Hollow					1
140	802176	• Flange, Mounting					1
150	802177	• Coupling					1
160	802178	• Spacer					1
170	802179	• Adapter, Shaft					1
175	802180	• Ring, Running					2
180	802181	• Flange					2
190	802182	• Housing, Gearbox					1
200	802183	• Fork, Gear					10
210	802184	• Bearing, Ball					1
220	802185	• Bearing, Ball					1
230	802186	• Bearing, Ball					1
240	802187	• Bearing, Ball					2
245	802188	• Bearing, Ball					1
250	802189	• Bearing					1
260	802190	• Bearing, Roller					1
270	802191	• Bearing, Roller					1
280	802192	• Seal, Radial Oil					1
290	802193	• Seal, Radial Oil					1
300	802194	• Seal, Radial Oil					2
310	802195	• O-Ring					1
315	802196	• O-Ring					1
320	802197	• O-Ring					1
330	802198	• O-Ring					1
335	802199	• O-Ring					2

DASH (-) ITEM NOT ILLUSTRATED

REVISION:

PTO GEAR BOX ASSEMBLY

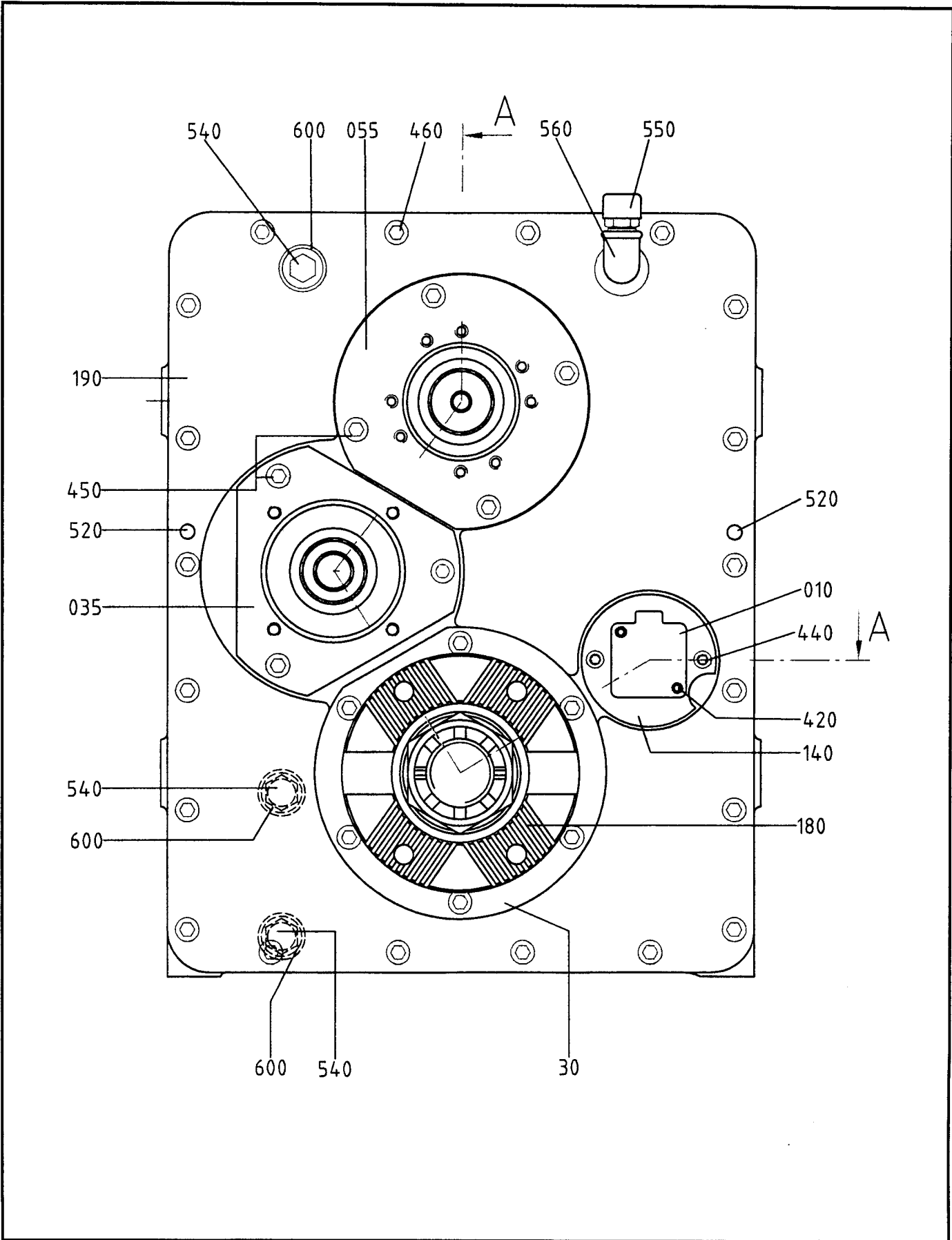

REVISION:



PTO GEAR BOX ASSEMBLY

XT 36
PARTS
GROUP 40
FIGURE 03
PAGE 03

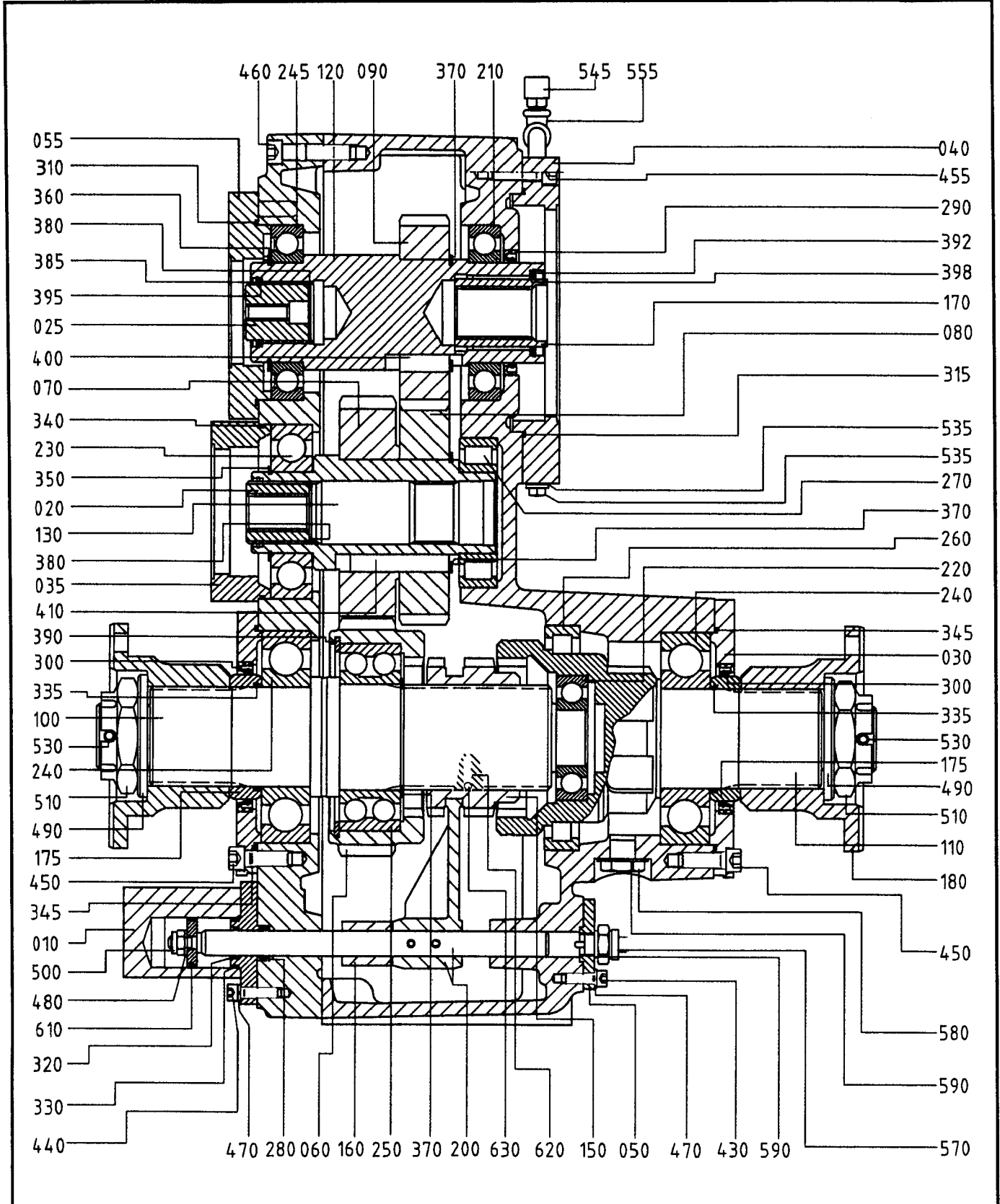

VIEW A-A

REVISION:

ITEM NO.	REED'S PARTS NO.	DESCRIPTION	QTY
340	802200	• O-Ring	1
345	802201	• O-Ring	2
350	802202	• Ring, Retaining	1
360	802203	• Ring, Retaining	1
370	802204	• Ring, Retaining	3
380	802205	• Ring, Retaining	2
385	802206	• Ring, Retaining	1
390	802207	• Ring, Retaining	1
392	802208	• Ring, Retaining	1
395	802209	• Disk, Support	1
398	802210	• Disk, Support	1
400	802211	• Key	2
410	802212	• Key	2
420	802213	• Screw, Socket Head Cap	2
430	802214	• Screw, Socket Head Cap	2
440	802215	• Screw, Socket Head Cap	2
450	802216	• Screw, Socket Head Cap	19
455	802217	• Screw, Socket Head Cap	8
460	802218	• Screw, Socket Head Cap	18
470	802219	• Washer, Lock	4
480	802220	• Disk	1
490	802221	• Disk	2
500	802222	• Nut, Hex	1
510	802223	• Nut, Castle	2
520	802224	• Pin	2
530	802225	• Pin, Spring	2
535	802226	• Plug, Hex Head	1
540	802227	• Plug, Hex Head	3
545	802228	• Filter, Vent	1
550	802229	• Filter, Vent	1
555	802230	• Elbow	2
560	802231	• Elbow	1
570	802232	• Switch, Limit	1
580	802233	• Plug, Hex Head	1
-585	802234	• Ring, Sealing	1
590	802235	• Ring, Sealing	2
600	802236	• Ring, Sealing	3
-605	802237	• Plug, Screw	2
610	802238	• Assembly, Piston	1
-615	802239	• Plug, Screw	1
620	802240	• Spring	1
630	802241	• Ball, 1/4 IN	1

DASH (-) ITEM NOT ILLUSTRATED

REVISION:



**MODEL XT 36 TRUCK MOUNTED
CONCRETE BOOM PUMP
ILLUSTRATED PARTS MANUAL**

**XT 36
PARTS
GROUP 40
FIGURE 04
PAGE 01**

THIS PAGE INTENTIONALLY LEFT BLANK.

REED TRUCK MOUNTED CONCRETE BOOM PUMP MODEL XT 36 ILLUSTRATED PARTS MANUAL GROUP 50 CONTROLS INSTALLATION CONTAINS THE FOLLOWING FIGURES:

- FIGURE 00** TABLE OF CONTENTS
- FIGURE 01** CONTROLS INSTALLATION
- FIGURE 02** CAB CONTROLS ASSEMBLY
- FIGURE 03** MAIN CONTROLS ASSEMBLY
- FIGURE 04** LH SIDE OUTRIGGER CONTROLS ASSEMBLY
- FIGURE 05** RH SIDE OUTRIGGER CONTROLS ASSEMBLY
- FIGURE 06** STATIONARY BOOM CONTROLS ASSEMBLY
- FIGURE 07** CABLED REMOTE CONTROL ASSEMBLY
- FIGURE 08** RADIO REMOTE CONTROL ASSEMBLY
- FIGURE 09** SHUNT ASSEMBLY

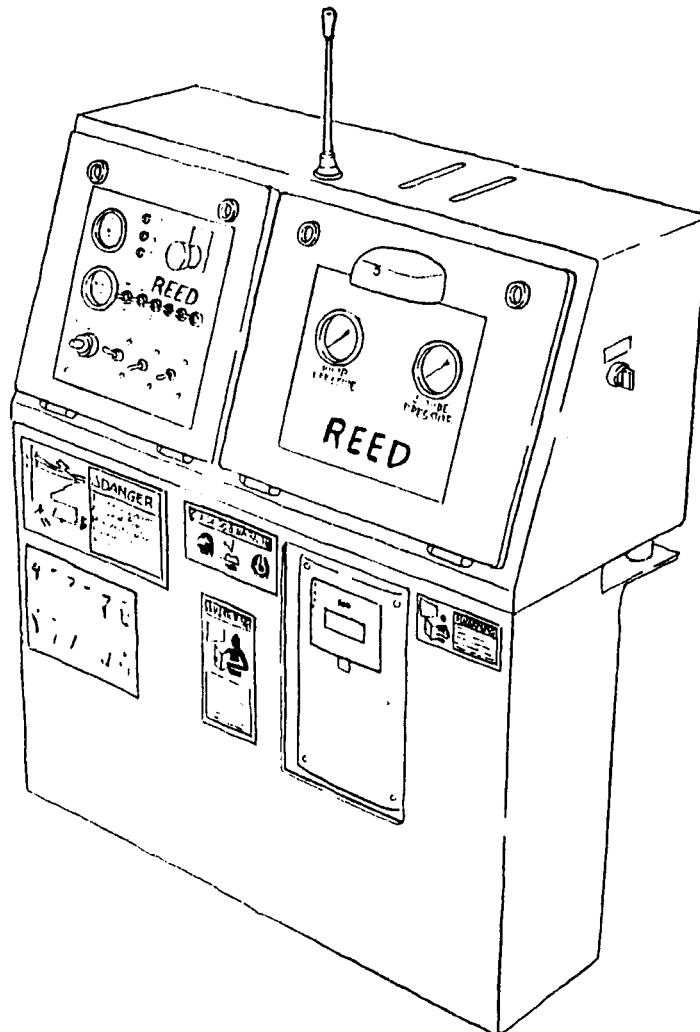

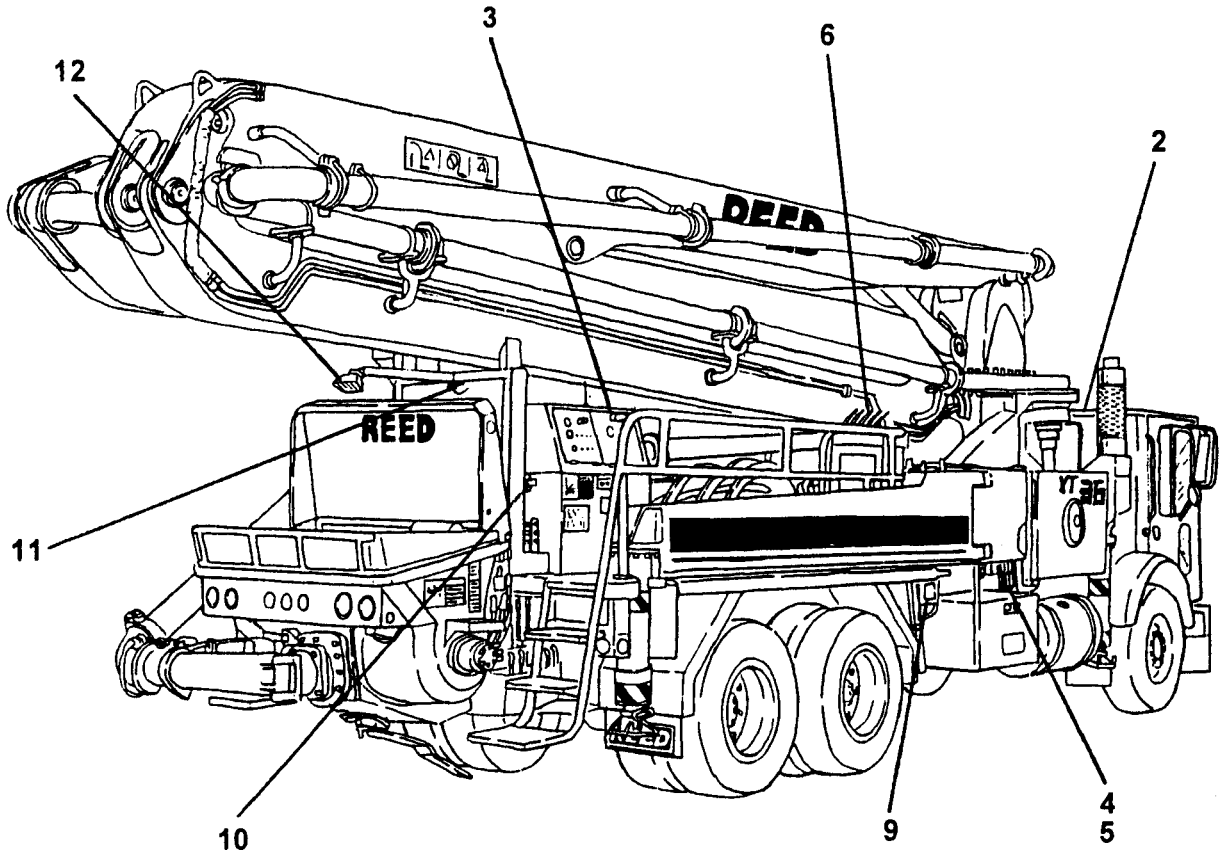

ITEM NO.	REED'S PARTS NO.	DESCRIPTION					QTY
		1	2	3	4	5	
-1	50-01	Installation, XT 36 Controls (See Group 10, Figure 01 for NHA)					Ref
2	800710	• Assembly, Cab Controls (See Group 50, Figure 02 for DET)					1
3	50-03	• Assembly, Main Controls (See Group 50, Figure 03 for DET)					1
4	50-04	• Assembly, Driver (L. H.) Side Outrigger Controls (See Group 50, Figure 04 for DET)					1
5	50-05	• Assembly, Passenger (R. H.) Side Outrigger Controls (See Group 50, Figure 05 for DET)					1
6	802135	• Assembly, Stationary Boom Controls (See Group 50, Figure 06 for DET)					1
-7	W-105983	• Assembly, Cabled Remote Control (See Group 50, Figure 07 for DET)					1
-8	W-105982	• Assembly, Radio Remote Control (See Group 50, Figure 08 for DET)					1
9	C-VW00587	• Assembly, Shunt (See Group 50, Figure 09 for DET)					1
10	800347	• Horn, 12V					1
11	800072	• Switch, Limit					1
12	800095	• Light, Floor Work					1

DASH (-) ITEM NOT ILLUSTRATED

CAB CONTROLS ASSEMBLY

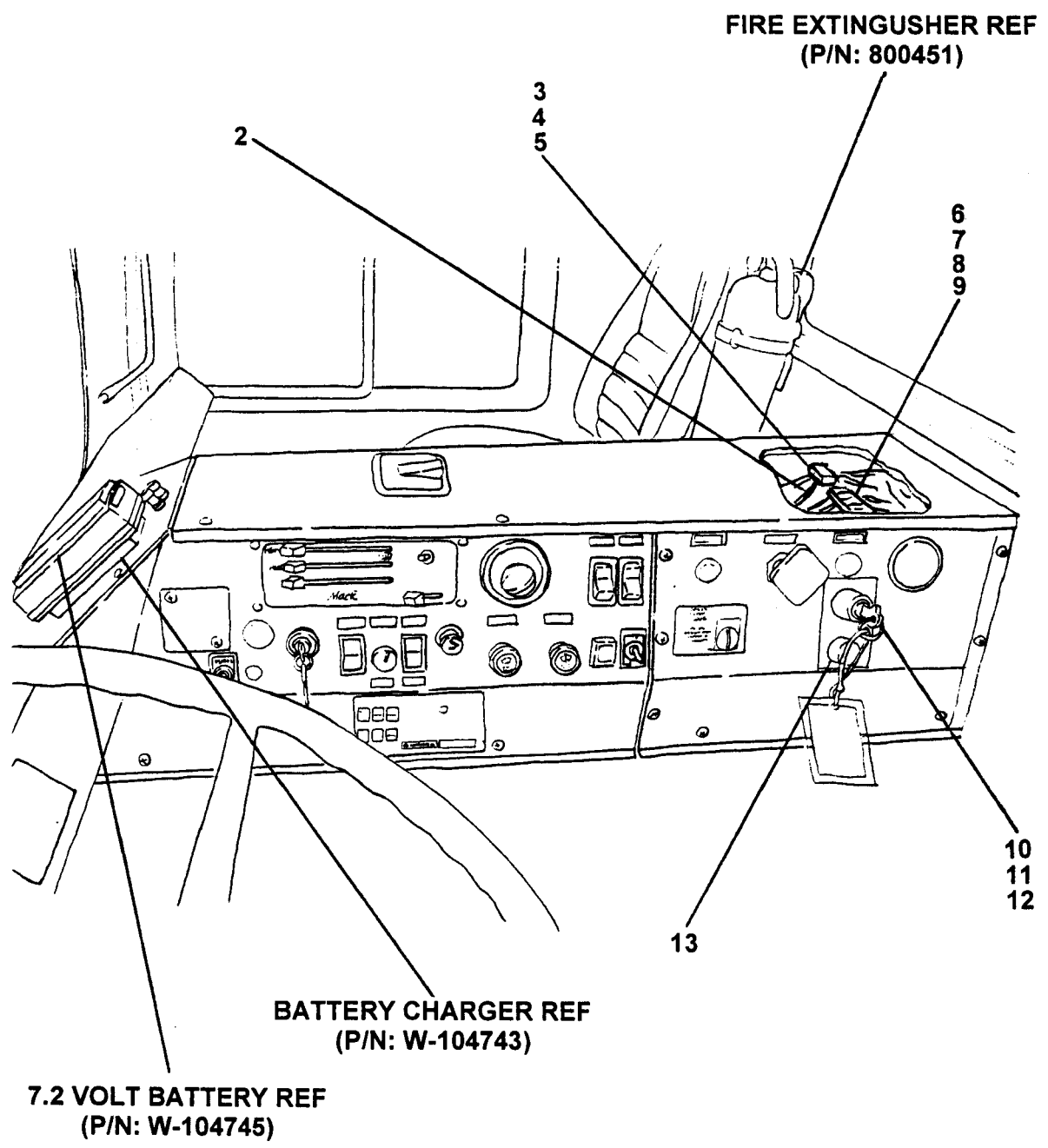

ITEM NO.	REED'S PARTS NO.	DESCRIPTION					QTY
		1	2	3	4	5	
-1	800710	Assembly, Cab Controls (See Group 50, Figure 01 for NHA)					1
2	10194	• Cable, 50 FT					1
3	800433	• Block, Fuse					1
4	800448	• Fuse, ATO 20					2
5	90392	• Fuse, ATO 5					1
6	72820	• Terminal					13
7	75654	• End, Barrier					1
8	72821	• Rail, Terminal					1
9	72824	• Jumper					3
10	800369	• Operator, Key					1
11	800370	• Block, Contact					1
12	800864	• Block, Contact					2
13	800414	• Light, Green Pilot					1
-14	800965	• Switch, Pressure (Located Near Engine)					1
-15	800909	• Switch, Clutch Limit (Located under Clutch Pedal)					1

DASH (-) ITEM NOT ILLUSTRATED



MAIN CONTROLS ASSEMBLY

XT 36
PARTS
GROUP 50
FIGURE 03
PAGE 01

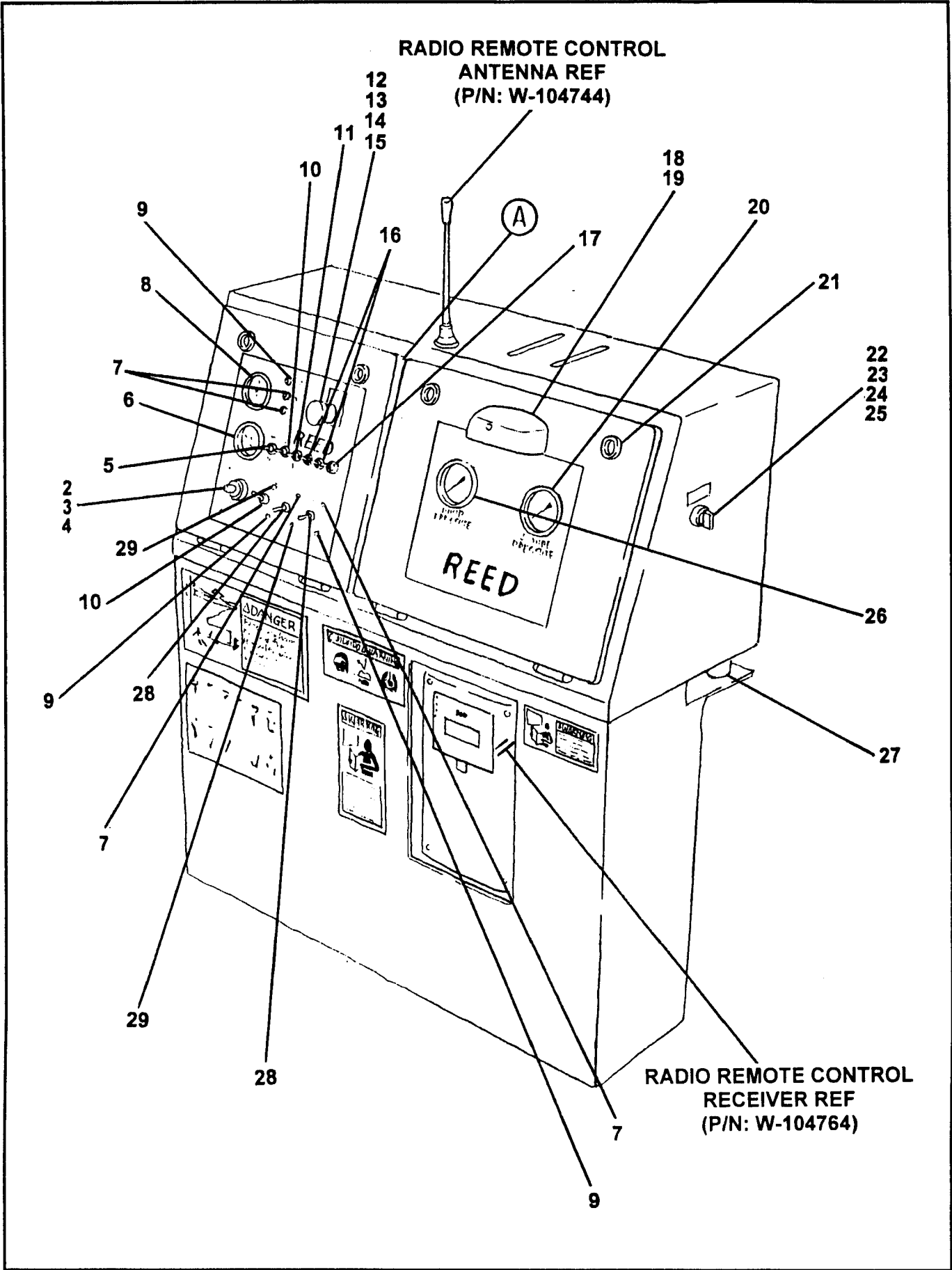

REVISION:

ITEM NO.	REED'S PARTS NO.	DESCRIPTION					QTY
		1	2	3	4	5	
-1	50-03	Assembly, Main Controls (See Group 50, Figure 01 for NHA)					Ref
2		• Assembly, Volume Control					1
3	W-104103	• • Potentiometer					1
4	W-104104	• • Body, Mounting					1
5	W-103976	• Switch, RPM Toggle					1
6	W-100900	• Meter, Hour					1
7	W-105811	• Light, Red Indicator					4
8	W-105823	• Thermometer					1
9	W-105813	• Light, Green Indicator					3
10	W-104090	• Switch, Vibrator / Pump Rev Toggle					2
11	W-104089	• Switch, Light / S-Tube / Pump Rev Toggle					3
12	W-105094	• Button, Emergency Stop					1
13	W-105095	• Element, Emergency Stop Contact					1
14	W-102278	• Nameplate, Emergency Stop					1
15	W-104083	• Light, Emergency					1
16	W-104091	• Switch, Lube / Horn Toggle					1
17	W-104089	• Switch, Lever					1
18	W-101033	• Assembly, Light					1
19	W-104101	• • Bulb, Replacement					1
20	70366	• Gauge, 3000 PSI Pressure					1
21		• Lock, Twist					4
22	W-100968	• Switch, A & B Momentary Rotary					1
23	W-100969	• Contact, A & B Switch					3
24	W-103735	• Bridge, A & B Switch					1
25	W-100287	• Base, A & B Switch					1
26	79831	• Gauge, 6000 PSI Pressure					1
27		• Mount, Rubber					A/R
28	72826	• Switch, On - On					1
29	W-105812	• Light, Yellow Indicator					2

DASH (-) ITEM NOT ILLUSTRATED

MAIN CONTROLS ASSEMBLY

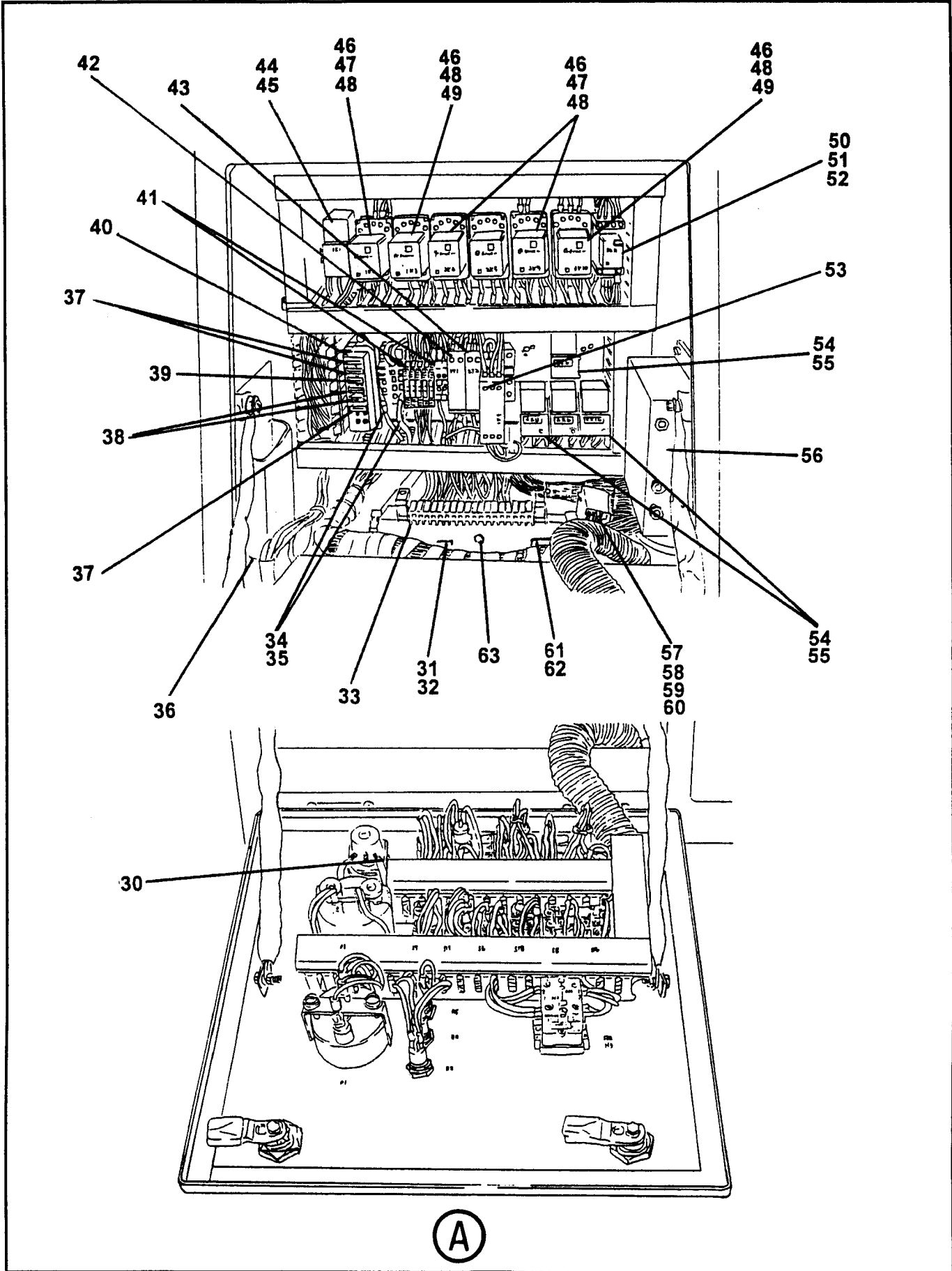

ITEM NO.	REED'S PARTS NO.	DESCRIPTION	QTY
30	W-104118	• Resistor, 100 OHM	1
31	W-100710	• Contact, 24 Pin Female (A)	1
32	W-101553	• Contact, 24 Pin Housing (A)	1
33	W-102577	• Block, Terminal	1
34	W-105817	• Clamp	2
35	W-105818	• Plate, End	2
36	W-104099	• Bag, Circuit Diagram	1
37	W-101921	• Fuse, 10 AMP	3
38	W-104096	• Fuse, 20 AMP	2
39	W-101922	• Fuse, 5 AMP	1
40	W-101577	• Holder, 8 Type Fuse	1
41	W-104185	• Diode	4
42	W-105331	• Relay, Time	1
43	W-105815	• Relay	1
44	W-105619	• Socket, Relay	1
45	W-104122	• Relay	1
46	W-104094	• Clip	6
47	W-100178	• Clip	4
48	W-104093	• Relay	6
49	W-104895	• Clip	2
50	W-103974	• Socket, Relay	1
51	W-105046	• Relay, Type 55.34	1
52	W-104860	• Clip	1
53	W-105814	• Element, Emergency Stop	1
54	W-100986	• Socket, Relay Bosch	4
55	W-104117	• Relay, Bosch	4
56	800461	• Box, Black	1
57	W-103693	• Contact, 8 Pin Female (C)	1
58	W-105816	• Contact, 8 Pin Housing (C)	1
59	W-103695	• Contact, Crimp (C)	1
60	W-103697	• Contact, Crimp (C)	1
61	W-104022	• Contact, 16 Pin Female (B)	1
62	W-104097	• Contact, 16 Pin Housing (B)	1
63	W-104669	• Condenser	1

DASH (-) ITEM NOT ILLUSTRATED

DRIVER SIDE (LEFT HAND) OUTRIGGER CONTROLS ASSEMBLY

XT 36
PARTS
GROUP 50
FIGURE 04
PAGE 01

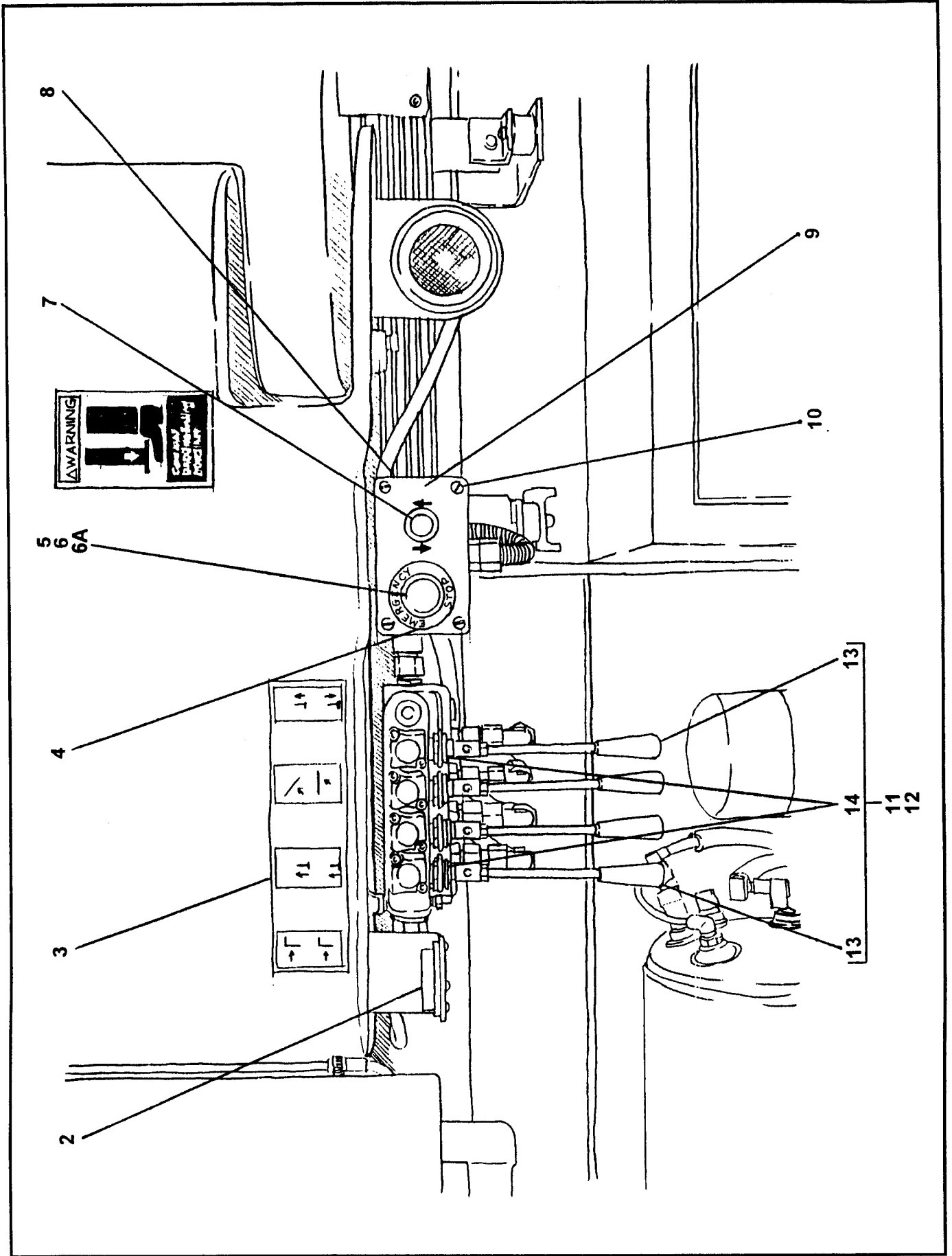

ITEM NO.	REED'S PARTS NO.	DESCRIPTION					QTY
		1	2	3	4	5	
-1	50-04	Assembly, Driver (L. H.) Side Outrigger Controls (See Group 50, Figure 01 for NHA)					Ref
2	800099	• Level, Bubble					1
3	802270	• Nameplate, XT 36 Left Side Outrigger					1
4	W-102278	• Nameplate, Emergency					1
5	W-105094	• Button, Emergency Stop					1
6	W-105095	• Element, Emergency Stop Contact					1
6A	W-104083	• Light, Emergency					1
7	W-100569	• Button, Push Operation					1
8		• Box, Non-Keyed Junction					1
9		• Decal, Non-Keyed Junction Box					1
10	W-103735	• Screw, Twist Lock Spring (attaching parts)					4
11	802143	• Assembly, L. H. Outrigger Control Valve					1
12		• • Lever					4
13		• • • Lever, Knob					1
14		• • • Boot, Rubber					1

DASH (-) ITEM NOT ILLUSTRATED

PASSENGER SIDE (RIGHT HAND) OUTRIGGER CONTROLS ASSEMBLY

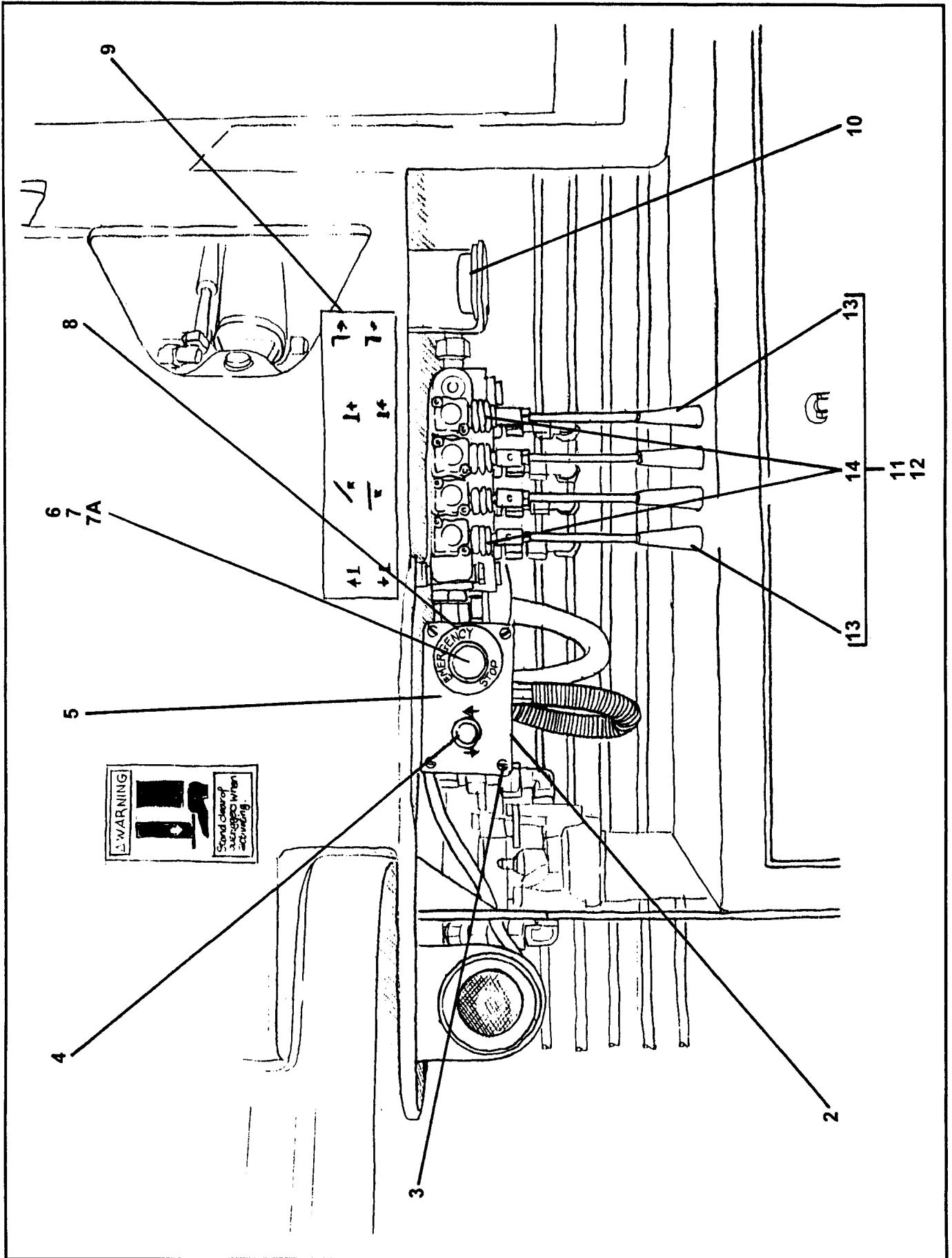

ITEM NO.	REED'S PARTS NO.	DESCRIPTION					QTY
		1	2	3	4	5	
-1	50-05	Assembly, Passenger (R. H.) Side Outrigger Controls (See Group 50, Figure 01 for NHA)					Ref
2		• Box, Keyed Junction					1
3	W-103735	• Screw, Twist Lock Spring (attaching parts)					4
4	C-EI001	• Button, Push Operation					1
5		• Decal, Keyed Junction Box					1
6	W-105094	• Button, Emergency Stop					1
7	W-105095	• Element, Emergency Stop Contact					1
7A	W-104083	• Light, Emergency					1
8	W-102278	• Nameplate, Emergency					1
9	802271	• Nameplate, XT 36 Right Side Outrigger					1
10	800099	• Level, Bubble					1
11	802142	• Assembly, R. H. Outrigger Control Valve					1
12		•• Lever					4
13		••• Lever, Knob					1
14		••• Boot, Rubber					1

DASH (-) ITEM NOT ILLUSTRATED

STATIONARY BOOM CONTROLS ASSEMBLY

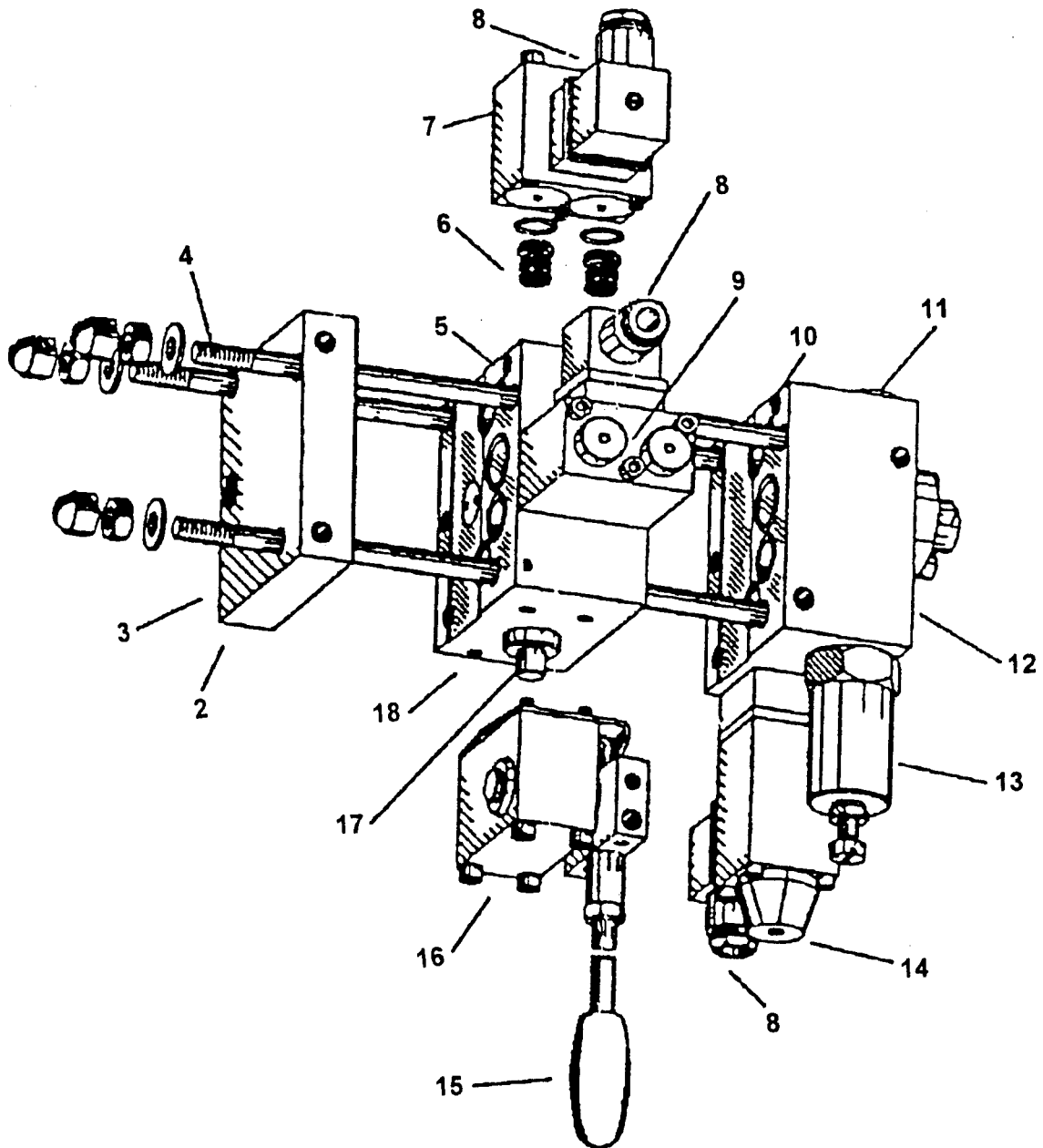

ITEM NO.	REED'S PARTS NO.	DESCRIPTION					QTY
		1	2	3	4	5	
-1	802135	Assembly, Boom Controls (See Group 50, Figure 01 for NHA)					Ref
2					• Plate, End	1	
3					• Valve, Check	1	
4					• Set, Tension Rod	1	
5					• Kit, Valve Section Seal	6	
6					• Valve, Press Reducing	6	
7					• Solenoid, Actuation	6	
8					• Plug, Solenoid	13	
9					• Solenoid, Function	6	
10					• Kit, Connection Block Seal	1	
11					• Valve, Pilot Press Reducing	1	
12					• Block, Connection	1	
13					• Valve, Pressure Limiting	1	
14					• Valve, Directional Seated	1	
15					• Lever, Hand	6	
16					• Housing, Actuation	6	
17					• Spool	6	
18					• Valve, Section	6	
-19	802272				• Nameplate, Boom Valve	1	

DASH (-) ITEM NOT ILLUSTRATED

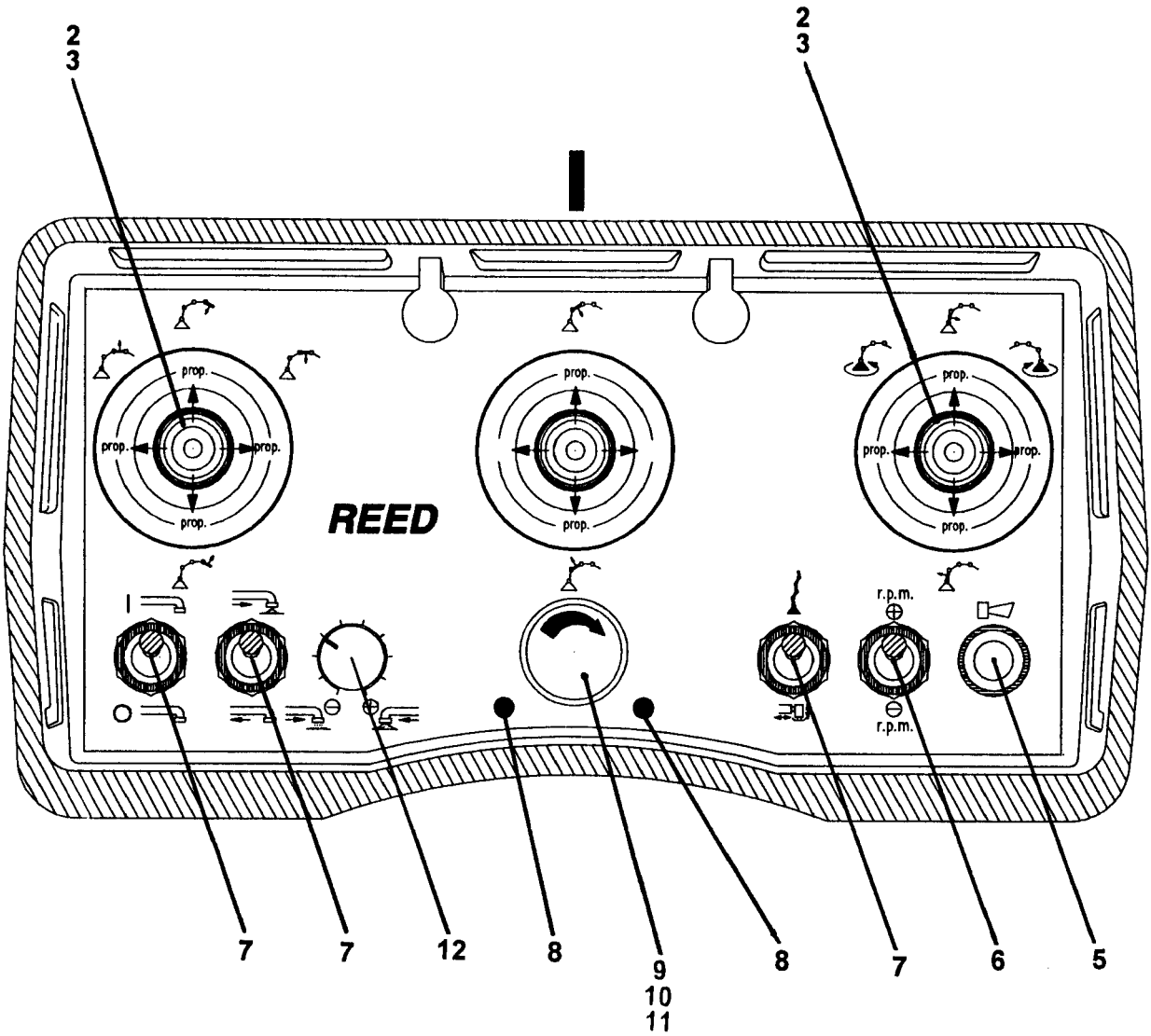

ITEM NO.	REED'S PARTS NO.	DESCRIPTION					QTY
		1	2	3	4	5	
-1	W-105983	Assembly, Cabled Remote Control (See Group 50, Figure 01 for NHA)					Ref
2		• Switch, Joy Stick Control					3
3		• • Boot, Rubber					3
-4		• Strap, Shoulder					1
5	3.740.1020	• Switch, O - Mom Push Button					1
6	3.740.1017	• Switch, Mom - O - Mom Toggle					1
7	3.740.1016	• Switch, On - O - On Toggle					3
8		• • Indicator, Light					2
9		• • Switch, Emergency Stop					1
10		• • • Knob, with Key					1
11		• • • Switch, Contact					1
12	3.980.1156	• • Potentiometer, with Knob					1

DASH (-) ITEM NOT ILLUSTRATED

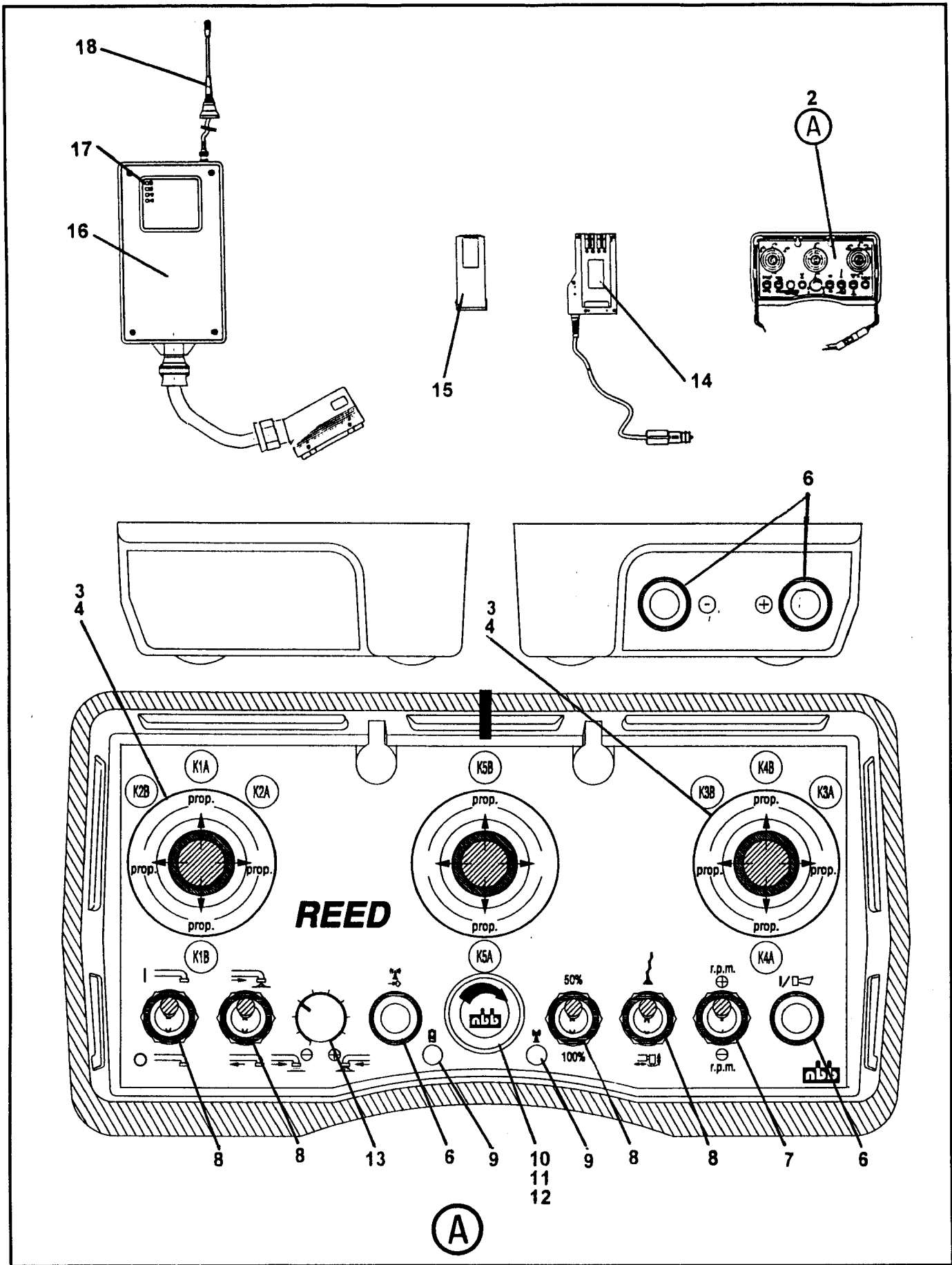

ITEM NO.	REED'S PARTS NO.	DESCRIPTION					QTY
		1	2	3	4	5	
-1	W-105983	Assembly, Radio Remote Control (See Group 50, Figure 01 for NHA)					Ref
2	W-106051	• Transmitter, Radio Remote Control					1
3		• • Switch, Joy Stick Control					3
4		• • • Boot, Rubber					1
-5		• • Strap, Shoulder					1
6	3.740.1020	• • Switch, O – Mom Push Button					2
7	3.740.1017	• • Switch, O – Mom Toggle					1
8	3.740.1016	• • Switch, On – O - On Toggle					4
9		• • Indicator, Light					2
10		• • Switch, Emergency Stop					1
11		• • • Knob, with Key					1
12		• • • Switch, Contact					1
13	3.980.1156	• • Potentiometer, with Knob					1
14	W-104743	• Charger, Battery (See Group 50, Figure 02 for REF)					1
15	W-104745	• Battery, 7.2V (See Group 50, Figure 02 for REF)					1
16	W-106052	• Receiver, Radio Remote Control (See Group 50, Figure 03 for REF)					1
17		• • Indicator, Light					5
18	W-104744	• Antenna, Radio Remote Control (See Group 50, Figure 03 for REF)					1

DASH (-) ITEM NOT ILLUSTRATED

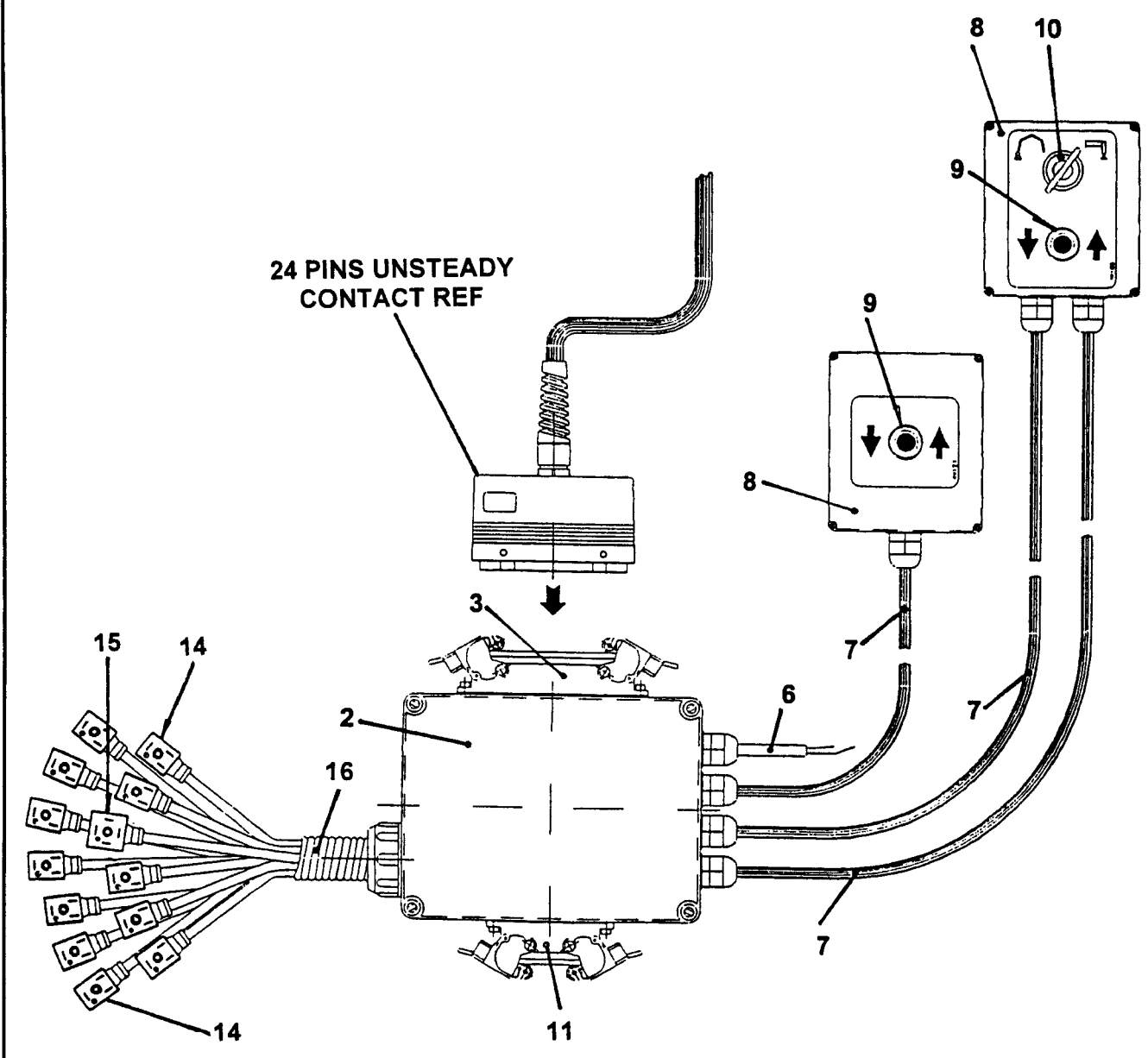

ITEM NO.	REED'S PARTS NO.	DESCRIPTION					QTY
		1	2	3	4	5	
-1	C-VW00587	Assembly, Shunt (See Group 50, Figure 01 for NHA)					Ref
2	C-WW00230	• • Box, Connector 214 X 162 X 92					1
3		• • Plug, 24 Points Contact					1
-4	C-WW00154	• • • Plug					1
-5	C-WW00167	• • • Case, Plug					1
6	C-WW00116	• • Cable, Electric 1.6 m					1
7	C-WW00265	• • Cable, Electric 4 m					3
8	C-ES001	• • Box, Junction					2
9	C-EI001	• • Switch					2
10	C-WW00190	• • Switch, 2 Position Key					1
11		• • Plug, 10 Points Auxiliary Contact					1
-12	C-WW00011	• • • Plug					1
-13	C-WW00037	• • • Case, Plug					1
14	C-WW00065	• • Plug, Rectangular with Cable					12
15	C-WW00175	• • Plug, Square with Electric Cable					1
16	C-WW00100	• • Cable, 1.5 m Sheath					1

DASH (-) ITEM NOT ILLUSTRATED



**MODEL XT 36 TRUCK MOUNTED
CONCRETE BOOM PUMP
ILLUSTRATED PARTS MANUAL**

**XT 36
PARTS
GROUP 50
FIGURE 10
PAGE 01**

THIS PAGE INTENTIONALLY LEFT BLANK.

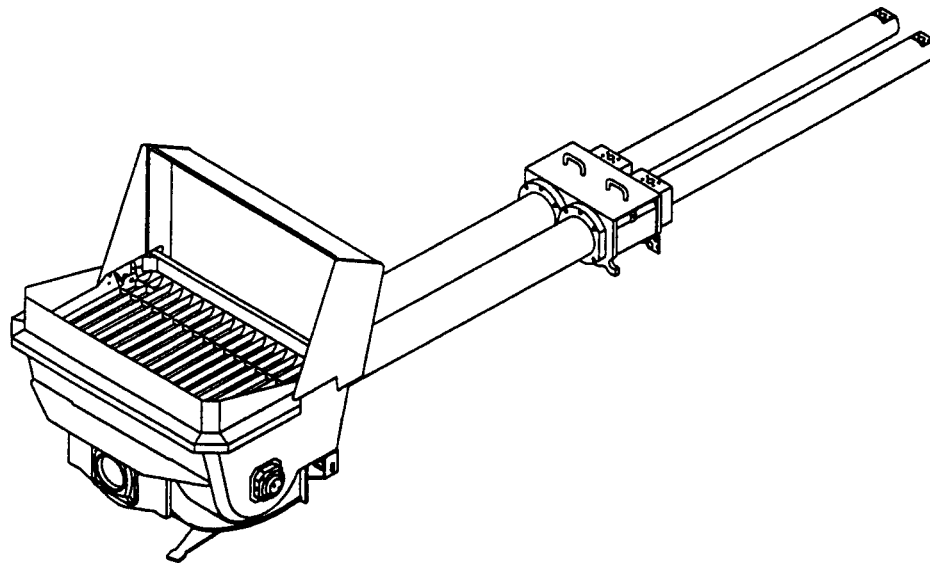

REED TRUCK MOUNTED CONCRETE BOOM PUMP MODEL XT 36 ILLUSTRATED PARTS MANUAL GROUP 60 PUMPING TRAIN INSTALLATION CONTAINS THE FOLLOWING FIGURES:

- | | |
|------------------|--|
| FIGURE 00 | TABLE OF CONTENTS |
| FIGURE 01 | PUMPING TRAIN INSTALLATION |
| FIGURE 02 | SWING VALVE ASSEMBLY |
| FIGURE 03 | TILTING DRIVE ASSEMBLY |
| FIGURE 04 | TILTING CYLINDER ASSEMBLY |
| FIGURE 05 | CONCRETE CYLINDER ASSEMBLY |
| FIGURE 06 | WATER BOX ASSEMBLY |
| FIGURE 07 | HYDRAULIC DRIVE CYLINDER ASSEMBLY |
| FIGURE 08 | DRIVE CYLINDER SUB-ASSEMBLY |



PUMPING TRAIN INSTALLATION

XT 36
PARTS
GROUP 60
FIGURE 01
PAGE 01

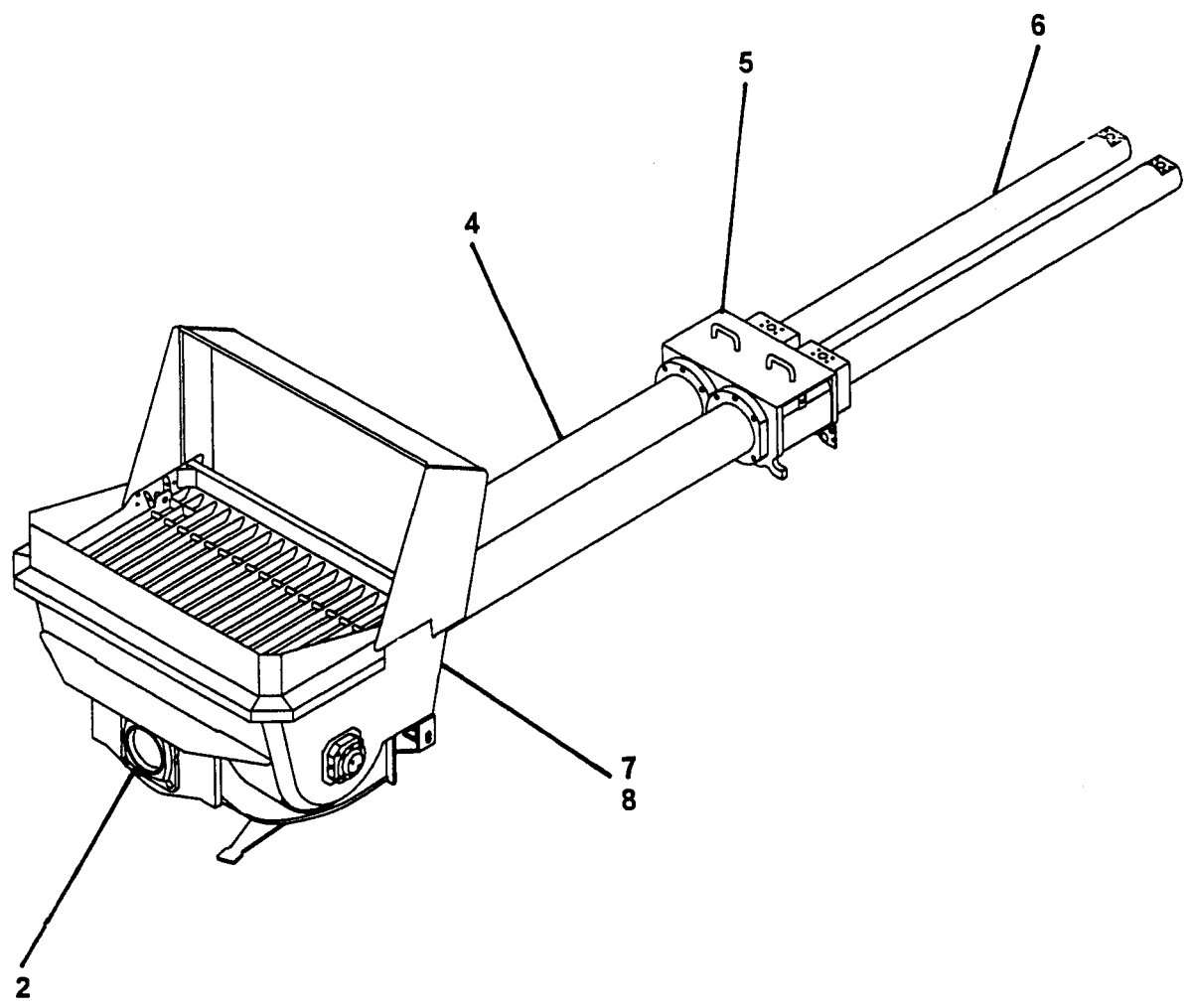

ITEM NO.	REED'S PARTS NO.	DESCRIPTION					QTY
		1	2	3	4	5	
-1	60-01	Installation, Pumping Train (See Group 10, Figure 01 for NHA)					Ref
2	B-174020	• Assembly, Swing Valve (See Group 60, Figure 02 for DET)					1
-3	B-174030	• Assembly, Tilting Drive (See Group 60, Figure 03 for DET)					1
4	B-124013	• Assembly, Concrete Cylinder (See Group 60, Figure 05 for DET)					1
5	B-143000	• Assembly, Water Box (See Group 60, Figure 06 for DET)					1
6	60-06	• Assembly, Hydraulic Drive Cylinder (See Group 60, Figure 07 for DET)					1
7	20-01	• Installation, Hopper (See Group 20, Figure 01 for REF)					Ref
8	B-184000	• System, Central Lubrication (See Group 20, Figure 02 for REF)					Ref

DASH (-) ITEM NOT ILLUSTRATED

REED

SWING VALVE ASSEMBLY

XT 36
PARTS
GROUP 60
FIGURE 02
PAGE 01

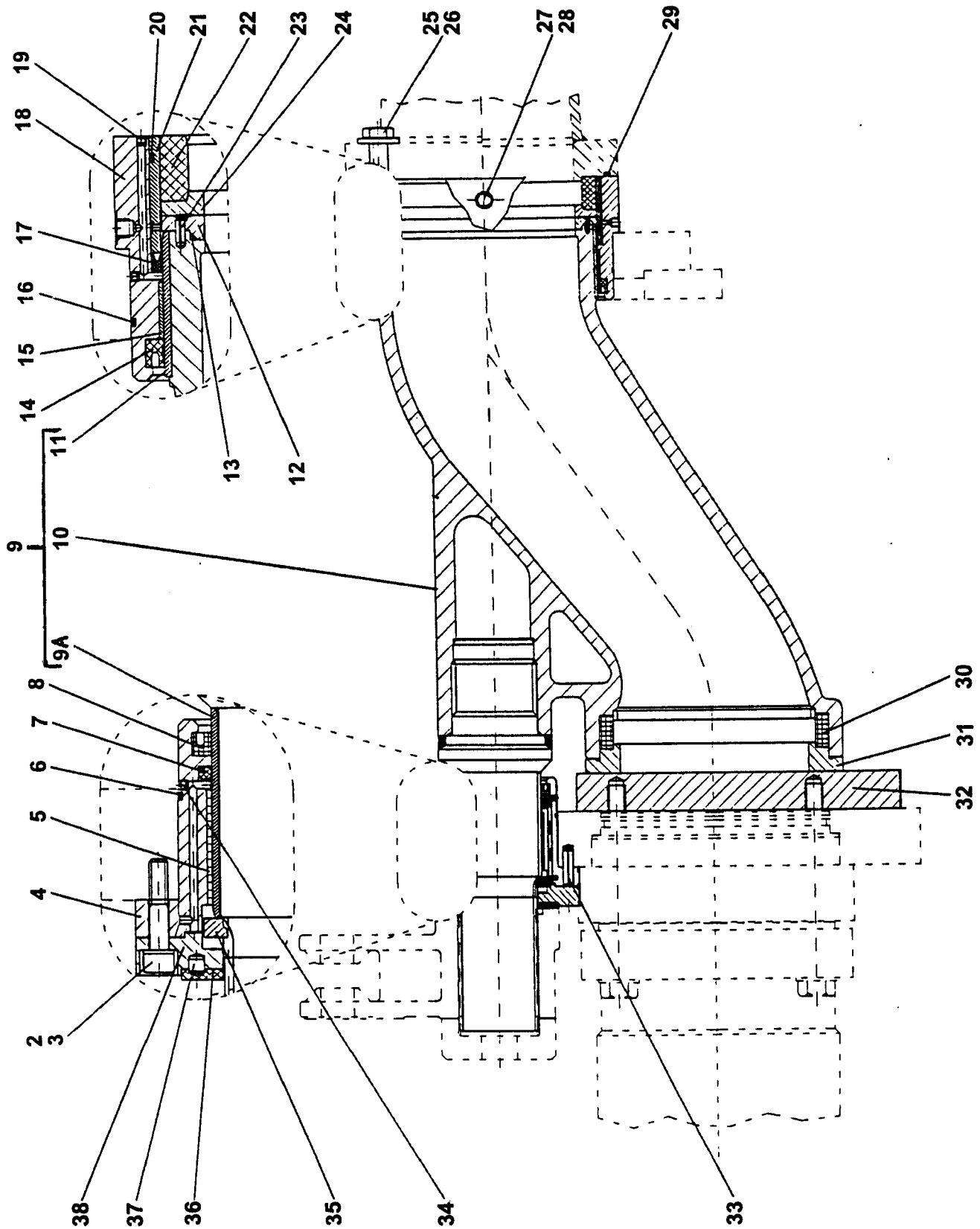

REVISION:

	REED'S PARTS NO.	1 2 3 4 5	DESCRIPTION	QTY
-1	B-174020		Assembly, Swing Valve (See Group 60, Figure 01 for NHA)	Ref
2	W-103151		• Screw, M12	3
3	W-103113		• Washer, Spring A12	3
4	B-174024		• Housing, Small Bearing	1
5	W-100237		• Bushing	1
6	W-100486		• O-Ring	2
7	W-100485		• O-Ring	2
8	W-100484		• Ring, Groove	1
9	W-105223		• Assembly, Swing Tube	1
9A	B-172105		• • Bushing, Small	1
10	B-174089		• • Valve, Swing DN 200	1
11	B-172107		• • Bushing, Big	1
12	B-174027		• Ring, Sliding	1
13	W-100625		• O-Ring	1
14	W-100479		• Ring, Groove	1
15	W-100236		• Ring, Outlet Wear	1
16	W-100481		• O-Ring	1
17	W-103078		• Foreseal	1
18	B-174022		• Housing, Big Bearing	1
19	W-100499		• Screw, M5 Set	2
20	W-103365		• O-Ring	1
21	B-174023		• Ring, Spacer	1
22	W-100262		• Ring, Outlet Wear	1
23	W-103077		• Pin, Spring Type Straight	2
24	B-174028		• Ring, Sliding	1
25	W-101589		• Screw, M20 Hex	4
26	W-102110		• Washer, A20	4
27	W-101621		• Screw, M8 Hex	1
28	W-101269		• Ring	1
29	W-101588		• O-Ring	1
30	W-103378		• Ring, Wear Ring Tension	1
31	B-174087		• Ring, Wear	1
32	B-174091		• Plate, Spectacle	1
33	W-103076		• Pin, Spring Type Straight	1
34	W-102710		• Screw, M4 Set	4
35	B-174026		• Profile	1
36	B-173012		• Washer, Phenolic Axial Bearing	1
37	W-103080		• Pin, Cylindrical	1
38	B-174025		• Flange	1

DASH (-) ITEM NOT ILLUSTRATED

REED

TILTING DRIVE ASSEMBLY

XT 36
PARTS
GROUP 60
FIGURE 03
PAGE 01

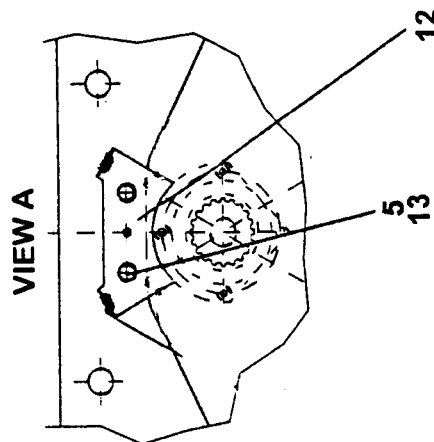
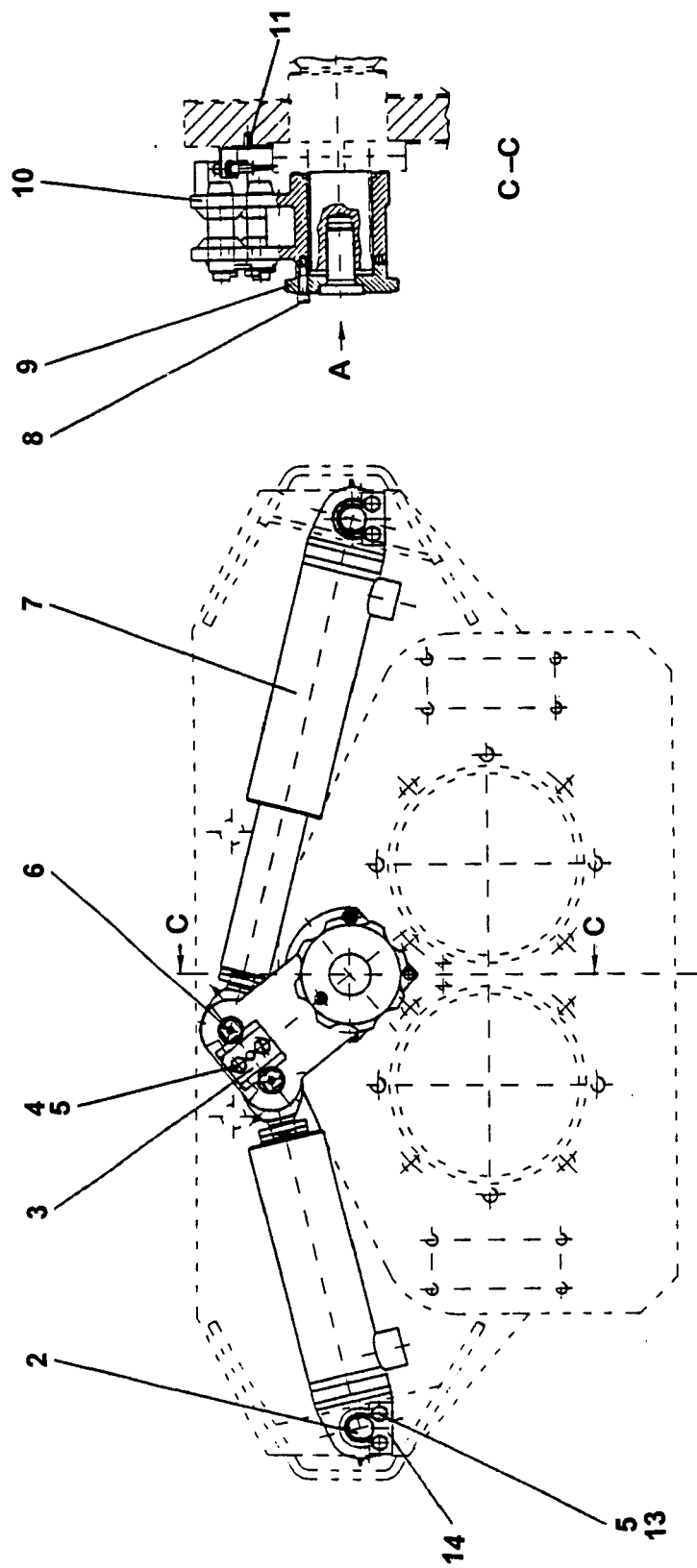



TILTING DRIVE ASSEMBLY

XT 36
PARTS
GROUP 60
FIGURE 03
PAGE 02

ITEM NO.	REED'S PARTS NO.	DESCRIPTION					QTY
		1	2	3	4	5	
-1	B-174030	Assembly, Tilting Drive (See Group 60, Figure 01 for NHA)					Ref
2	B-173066	• Pin, Safety					2
3	B-174083	• Plate, Key					1
4	W-102107	• Screw, M12 Hex					2
5	W-102877	• Washer, A12					8
6	B-173019	• Pin					2
7	W-103363	• Assembly, Tilting Cylinder (See Group 60, Figure 04 for DET)					2
8	B-174035	• Screw, M10 Hex (attaching parts)					1
9	B-174032	• Plate, Tension					1
10	B-174031	• Lever, Tilting					1
11	W-102881	• Pin, Spring Type Straight					1
12	B-174084	• Bracket, Sensor					1
13	W-101001	• Bolt, M12					6
14	B-173067	• Plate, Safety Pin					2

DASH (-) ITEM NOT ILLUSTRATED



TILTING CYLINDER ASSEMBLY

XT 36
PARTS
GROUP 60
FIGURE 04
PAGE 01

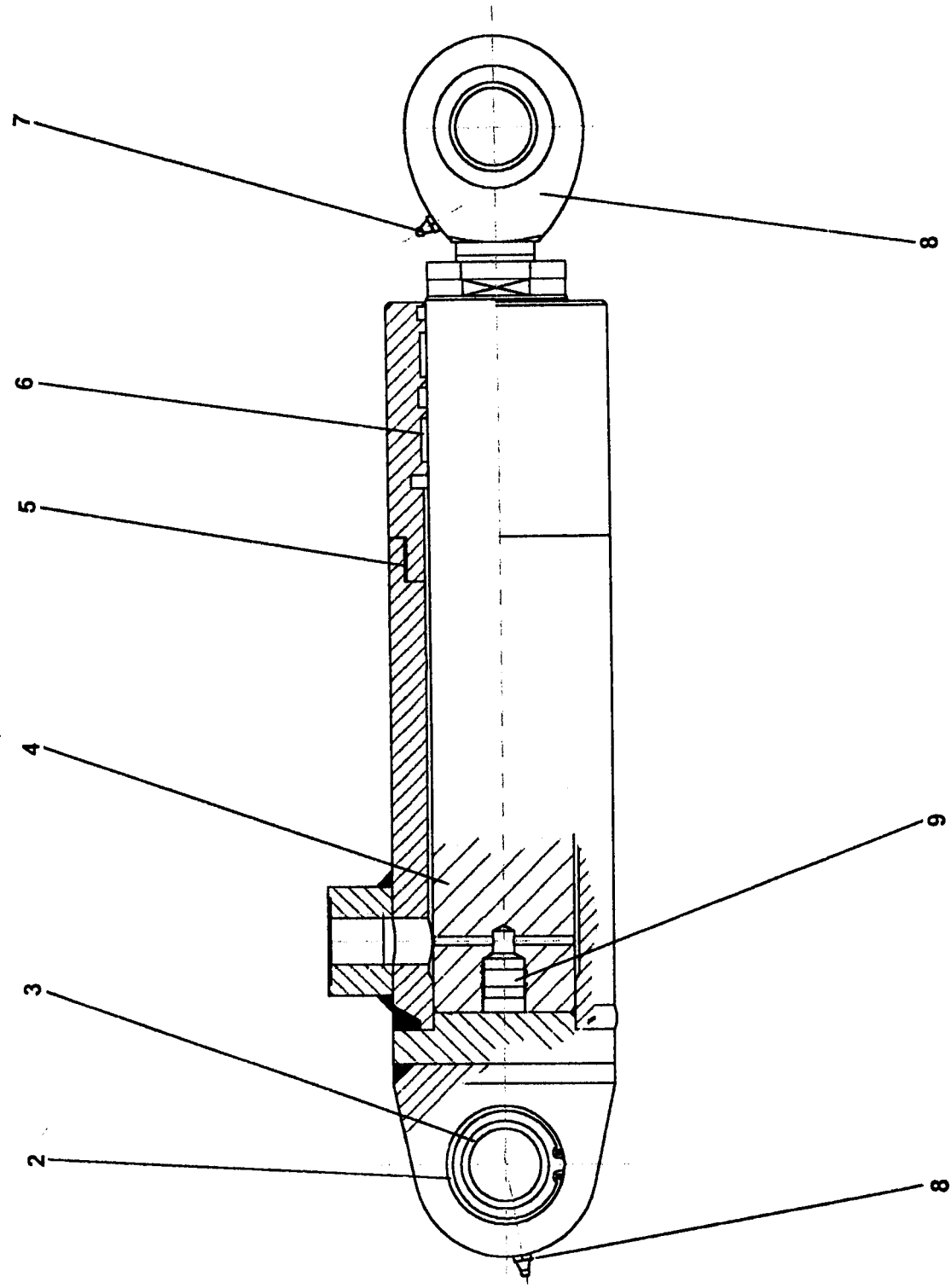

REED**TILTING CYLINDER ASSEMBLY****XT 36**
PARTS
GROUP 60
FIGURE 04
PAGE 02

ITEM NO.	REED'S PARTS NO.	DESCRIPTION					QTY
		1	2	3	4	5	
-1	W-103363	Assembly, Tilting Cylinder (See Group 60, Figure 03 for NHA)					Ref
2	W-103626	• Bearing					1
3	W-101973	• Ring, Retaining					1
4	W-104438	• Rod, Piston					1
5	W-104440	• Pipe, Cylinder					1
6	W-103364	• Kit, Seal					1
7	W-100805	• Nipple, Grease					2
8	W-104437	• Valve, Check					1
9	W-104439	• Head, Rod					1

DASH (-) ITEM NOT ILLUSTRATED

REED

CONCRETE CYLINDER ASSEMBLY

XT 36
PARTS
GROUP 60
FIGURE 05
PAGE 01

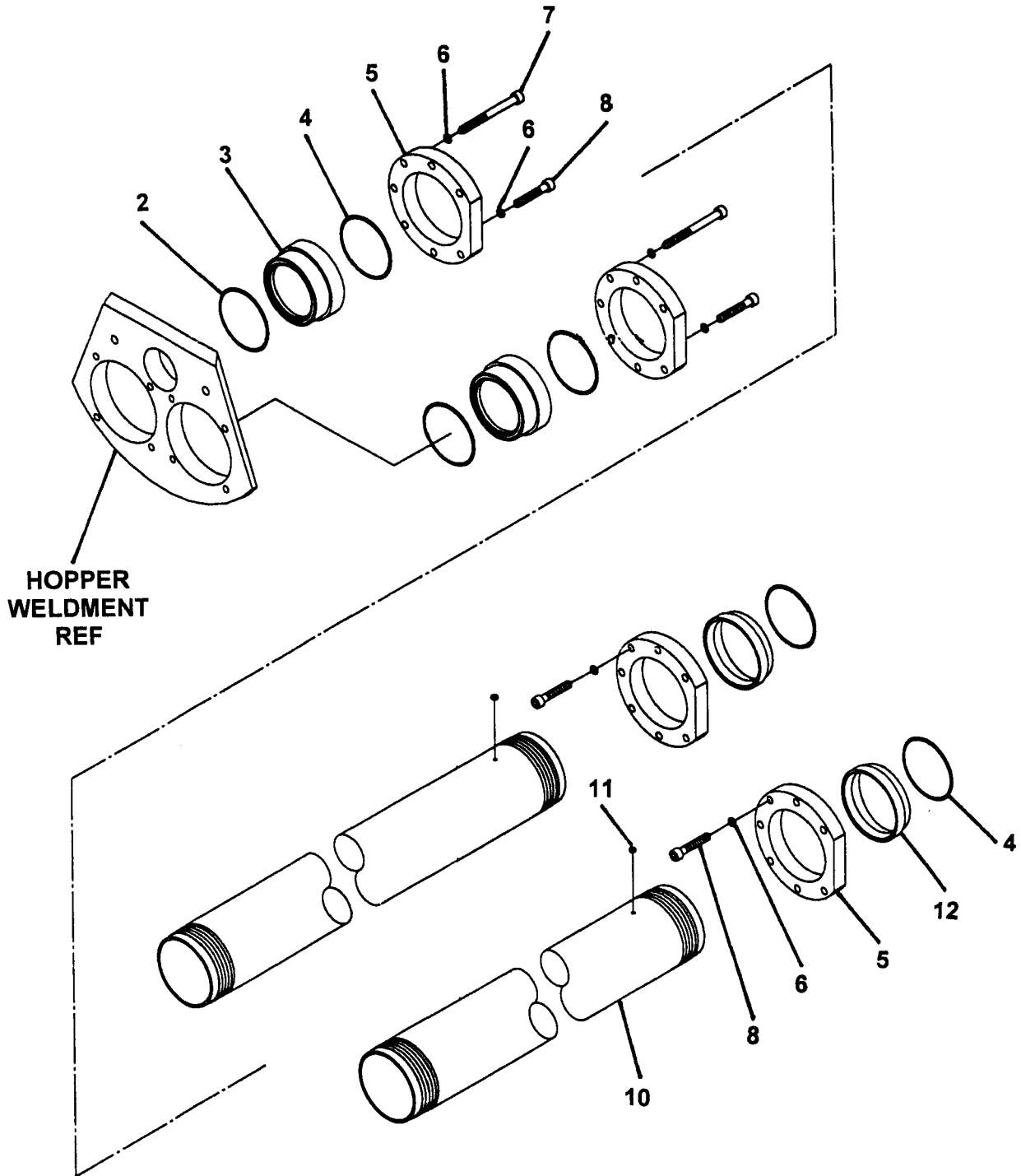

ITEM NO.	REED'S PARTS NO.	DESCRIPTION					QTY
		1	2	3	4	5	
-1	B-124017	Assembly, Concrete Cylinder (See Group 60, Figure 01 for NHA)					Ref
2	W-101090	• O-Ring					2
3	B-124015	• Ring, Fitting					2
4	W-102868	• O-Ring					4
5	B-123007	• Flange					4
6	W-100691	• Washer					28
7	W-102885	• Bolt, M20					6
8	W-103970	• Screw, M20					14
-9	W-102845	• Bolt, M20					8
10	B-123011	• Cylinder, Concrete					2
11		• Fitting, Grease					2
12	B-123012	• Ring, Fitting					2

DASH (-) ITEM NOT ILLUSTRATED

REED

WATER BOX ASSEMBLY

XT 36
PARTS
GROUP 60
FIGURE 06
PAGE 01

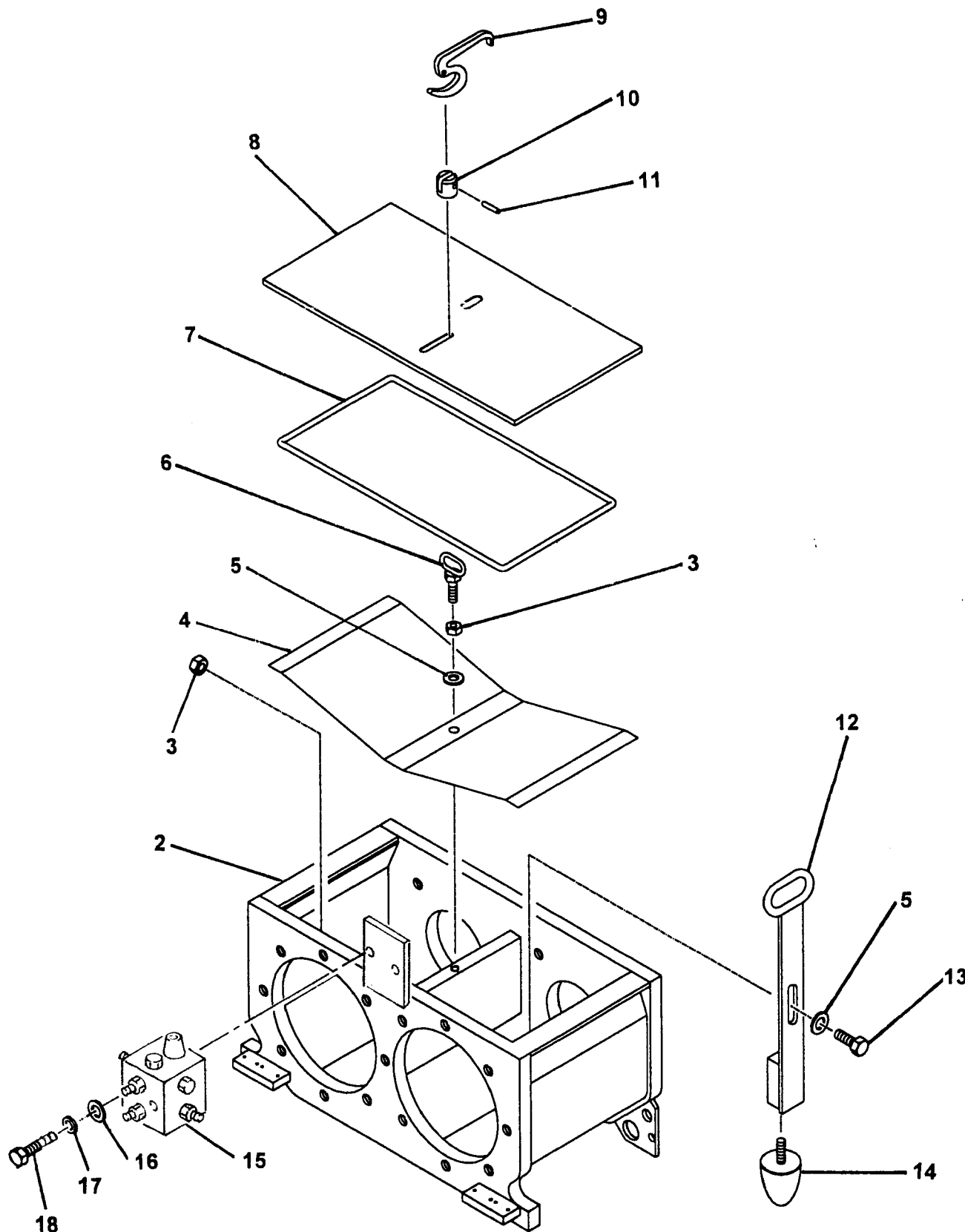

ITEM NO.	REED'S PARTS NO.	DESCRIPTION					QTY
		1	2	3	4	5	
-1	B-143030	Assembly, Water Box (See Group 60, Figure 01 for NHA)					Ref
2	B-143031	• Weldment, Water Box					1
3	W-101557	• Nut, M12 Hex					2
4	B-143020	• Cover, Safety					1
5	W-100504	• Washer					2
6	B-143009	• Bolt, M12 Eye					1
7	W-101831	• Seal, Round Cord					1
8	B-143015	• Cover, Water Box					1
9	B-143007	• Lever					1
10		• Head, Eye Bolt					1
11	W-103387	• Pin, Grooved					1
12	B-143011	• Handle					1
13	W-103688	• Bolt, M12 Hex					1
14	W-102712	• Buffer, Rubber					1
15	W-104402	• Block, Lube					1
16		• Washer, Flat (attaching parts)					2
17		• Washer, Lock (attaching parts)					2
18		• Bolt, Hex (attaching parts)					2

DASH (-) ITEM NOT ILLUSTRATED

REED

HYDRAULIC DRIVE CYLINDER ASSEMBLY

XT 36
PARTS
GROUP 60
FIGURE 07
PAGE 01

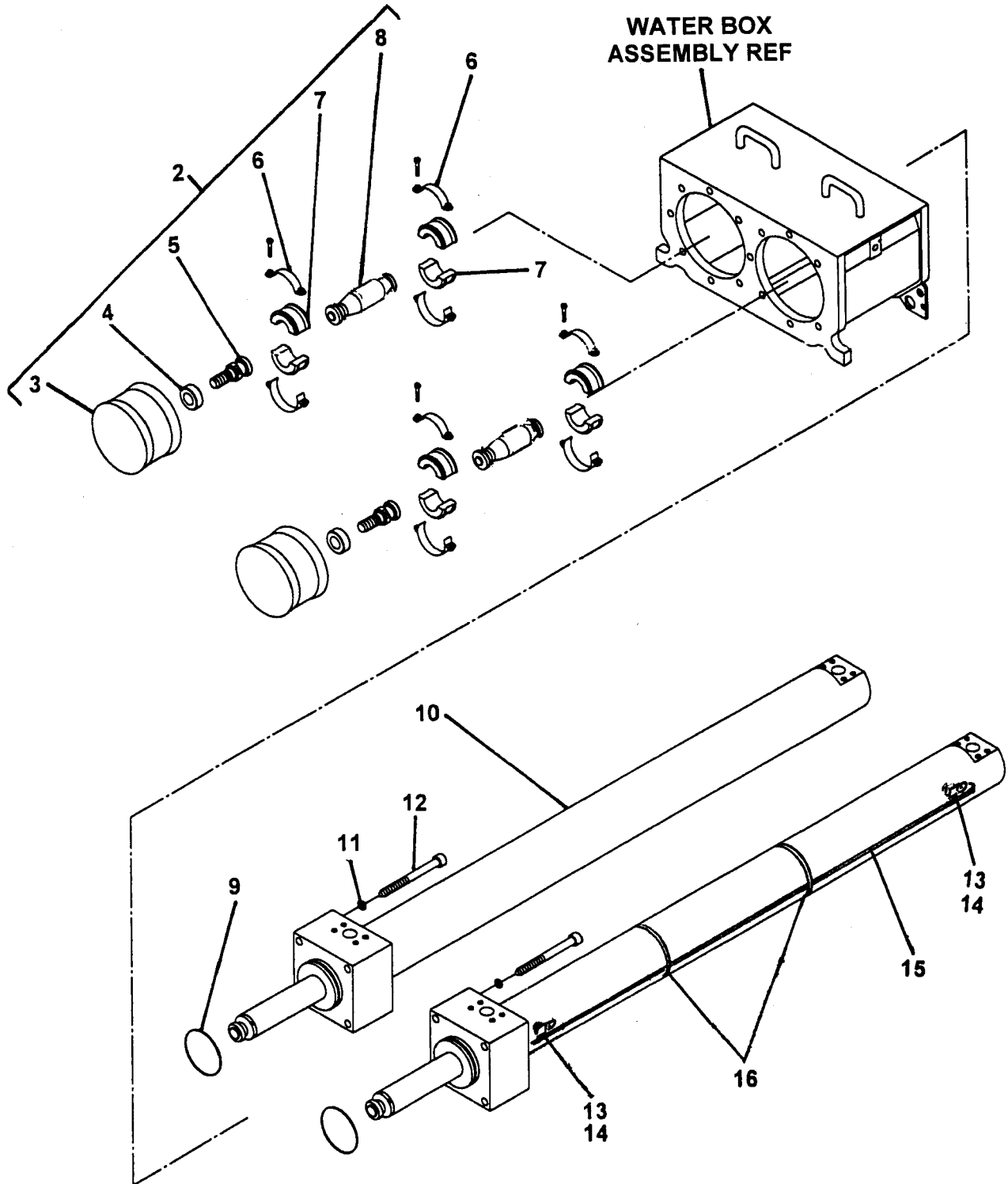

ITEM NO.	REED'S PARTS NO.	DESCRIPTION					QTY
		1	2	3	4	5	
-1	60-06	Assembly, Hydraulic Drive Cylinder (See Group 60, Figure 01 for NHA)					Ref
2	B-133012	• Assembly, Piston Ram					1
3	W-100175	• • Ram, Piston					2
4	W-100934	• • Ring, Fitting					2
5	B-131003	• • Pin, Coupling					2
6	W-101381	• • Clamp, Hose					4
7	B-131004	• • Coupling, Clamp					4
8	B-133003	• • Adapter, Dog Bone					2
9	W-100190	• O-Ring					2
10	B-154030	• Sub-Assembly, Hydraulic Drive Cylinder (See Group 60, Figure 08 for DET)					2
11	W-103070	• Washer (attaching parts)					6
12	W-102846	• Bolt (attaching parts)					6
13	79285	• Guard, Prox Switch					2
14	78416	• Switch, Prox					2
15	78417	• Cable, Prox Switch					2
16		• Tie-Down (attaching parts)					2

DASH (-) ITEM NOT ILLUSTRATED



HYDRAULIC DRIVE CYLINDER SUB-ASSEMBLY

XT 36
PARTS
GROUP 60
FIGURE 08
PAGE 01

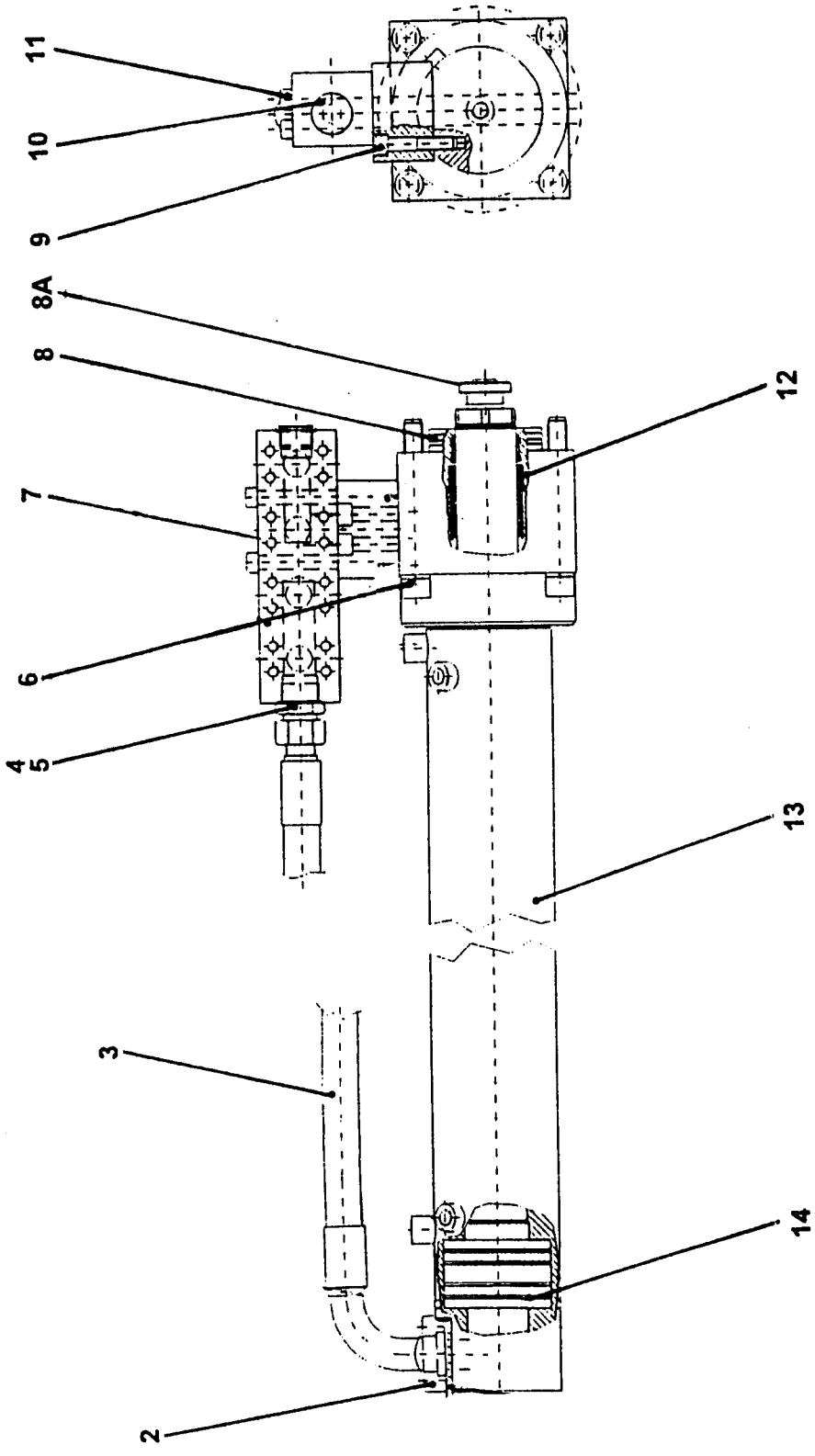



HYDRAULIC DRIVE CYLINDER SUB-ASSEMBLY

XT 36
PARTS
GROUP 60
FIGURE 08
PAGE 02

ITEM NO.	REED'S PARTS NO.	DESCRIPTION					QTY
		1	2	3	4	5	
-1	B-154030	Sub-Assembly, Hydraulic Drive Cylinder (See Group 60, Figure 07 for NHA)					Ref
2	W-102305	• Flange (set)					1
3		• Assembly, High Pressure Hose					1
4	W-102846	• Screw, M24					4
5	W-103070	• Washer, Spring					4
6	W-102184	• Coupling, Straight Male Stud					1
7	B-153002	• Box, Hydraulic					1
8	W-100190	• O-Ring					1
8A	W-104146	• Coupling, Piston					1
9		• Screw, M16					4
10	W-103347	• Screw, Locking					1
11		• Screw, M16					4
12	W-102393	• Set, Seal					1
13	W-102504	• Cylinder, Drive					1
14	W-105049	• Ring, Piston					4
-15	B-153003	• Block, Hydraulic					1
-16	78416	• Sensor, Proximity					2
-17	78417	• Cable, Proximity Sensor					2
-18	79285	• Guard, Proximity Sensor					2
-19		• Valve, Check					2

DASH (-) ITEM NOT ILLUSTRATED

REED

**MODEL XT 36 TRUCK MOUNTED
CONCRETE BOOM PUMP
ILLUSTRATED PARTS MANUAL**

**XT 36
PARTS
GROUP 60
FIGURE 09
PAGE 01**

THIS PAGE INTENTIONALLY LEFT BLANK.

REED TRUCK MOUNTED CONCRETE BOOM PUMP MODEL XT 36 ILLUSTRATED PARTS MANUAL GROUP 70 FRAME AND SUPPORT INSTALLATION CONTAINS THE FOLLOWING FIGURES:

- FIGURE 00** TABLE OF CONTENTS
- FIGURE 01** FRAME AND SUPPORT INSTALLATION
- FIGURE 02** TURRET ASSEMBLY
- FIGURE 03** MOTOR AND REDUCTION ASSEMBLY
- FIGURE 04** ROTATION UNIT ASSEMBLY
- FIGURE 05** PEDESTAL ASSEMBLY
- FIGURE 06** FRONT OUTRIGGER GROUP ASSEMBLY
- FIGURE 07** REAR OUTRIGGER GROUP ASSEMBLY
- FIGURE 08** OUTRIGGER EXTEND CYLINDER ASSEMBLY
- FIGURE 09** OUTRIGGER JACK CYLINDER ASSEMBLY
- FIGURE 10** SWING OUT CYLINDER ASSEMBLY
- FIGURE 11** RIGHT HAND SIDE HOSE REEL ASSEMBLY
- FIGURE 12** OUTRIGGER HOLDING VALVE ASSEMBLY

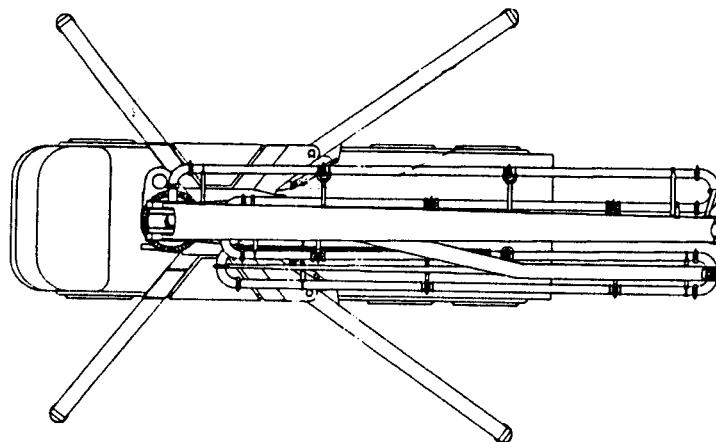
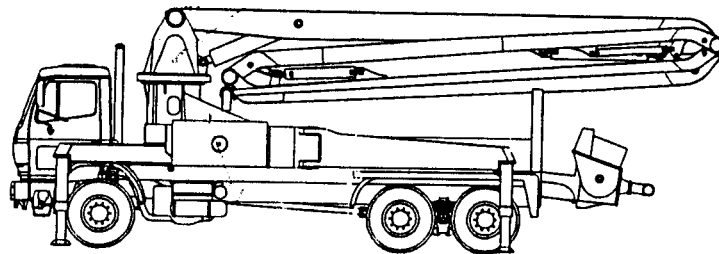

REED

FRAME AND SUPPORT INSTALLATION

XT 36
PARTS
GROUP 70
FIGURE 01
PAGE 01

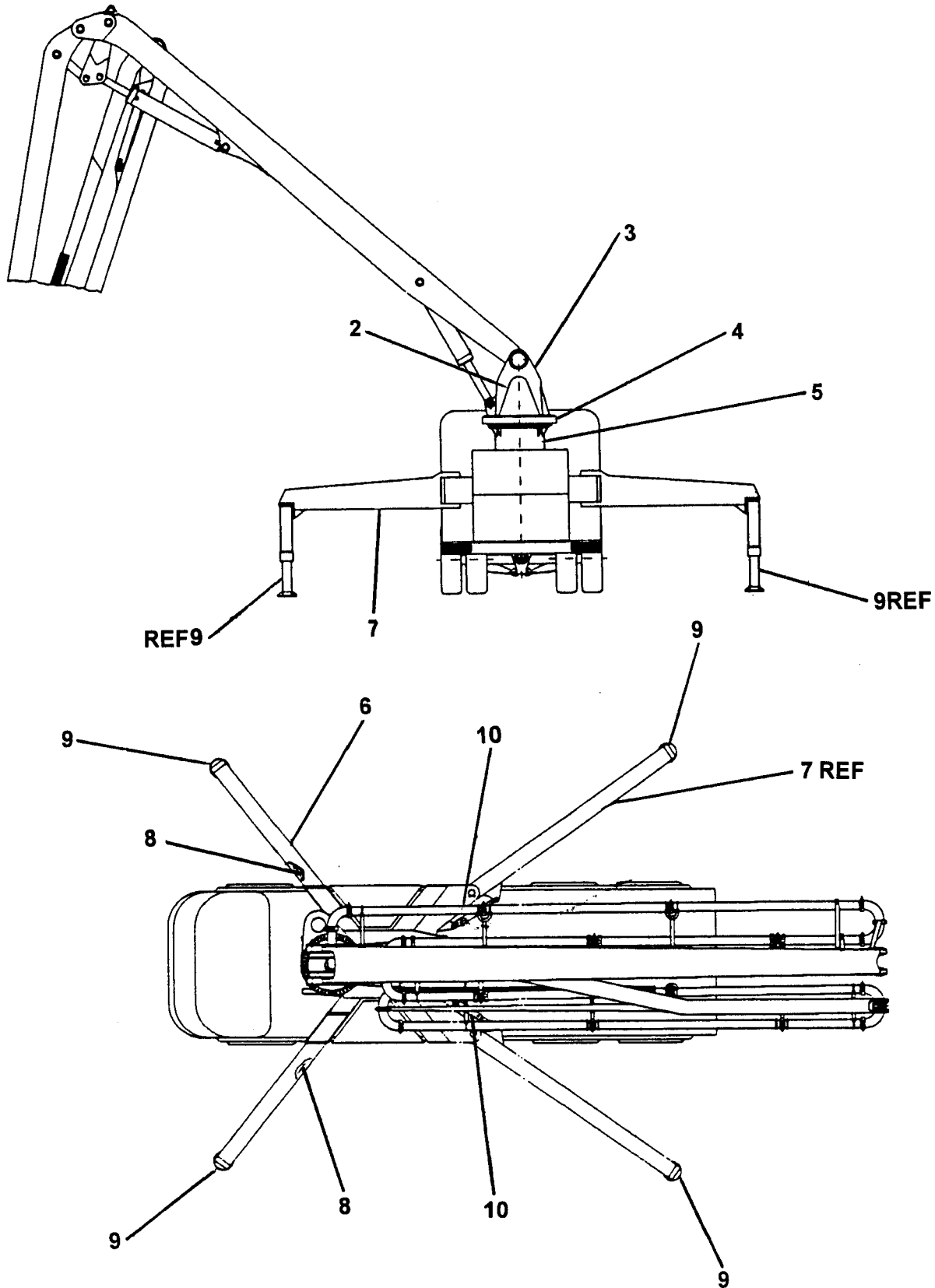

REVISION:

ITEM NO.	REED'S PARTS NO.	DESCRIPTION					QTY
		1	2	3	4	5	
-1	70-01	Installation, Frame And Support (See Group 10, Figure 01 for NHA)					Ref
2	B-681001	• Assembly, Turret (See Group 70, Figure 02 for DET)					1
3	C-8G1	• Assembly, Motor And Reduction (See Group 70, Figure 03 for DET)					1
4	C-8G2	• Assembly, Rotation Unit (See Group 70, Figure 04 for DET)					1
5	802102	• Assembly, Pedestal (See Group 70, Figure 05 for DET)					1
6	802105	• Assembly, Front Outrigger Group (See Group 70, Figure 06 for DET)					1
7	802106	• Assembly, Rear Outrigger Group (See Group 70, Figure 07 for DET)					1
8	802112	• Assembly, Outrigger Extend Cylinder (See Group 70, Figure 08 for DET)					2
9	802404	• Assembly, Outrigger Jack Cylinder (See Group 70, Figure 09 for DET)					4
10	802113	• Assembly, Rear Swing Out Cylinder (See Group 70, Figure 10 for DET)					2
-11	802130	• Assembly, Right Hand Side Hose Reel (See Group 70, Figure 11 for DET)					1
-12	802144	• Assembly, Outrigger Holding Valve (See Group 70, Figure 12 for DET)					4

DASH (-) ITEM NOT ILLUSTRATED



TURRET ASSEMBLY

XT 36
PARTS
GROUP 70
FIGURE 02
PAGE 01

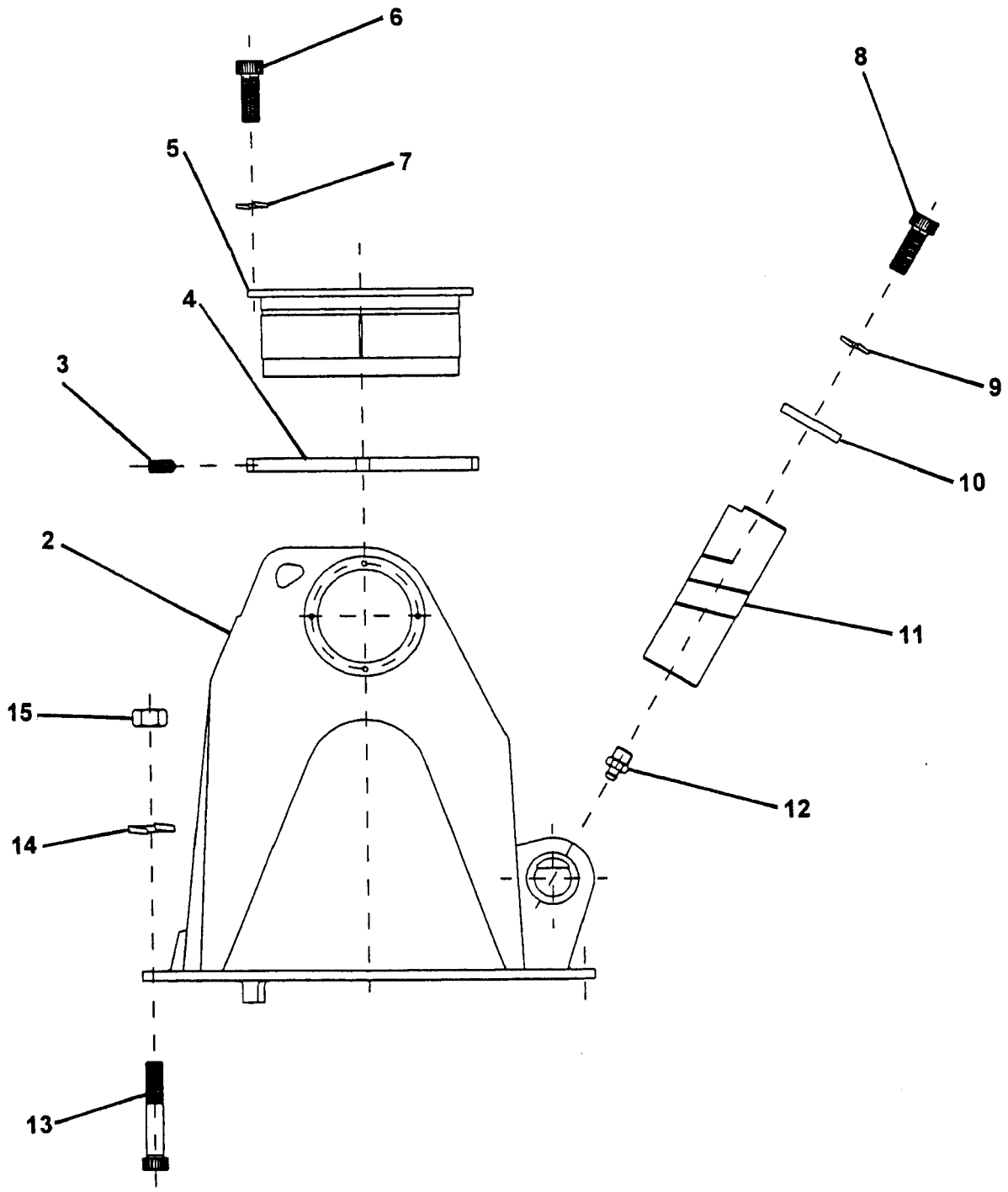
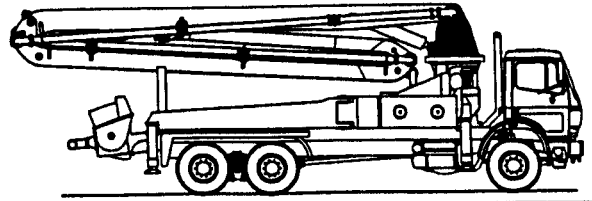
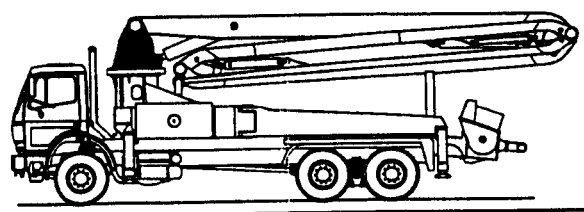

REVISION:



TURRET ASSEMBLY

XT 36
PARTS
GROUP 70
FIGURE 02
PAGE 02

ITEM NO.	REED'S PARTS NO.	DESCRIPTION					QTY
		1	2	3	4	5	
-1	B-681001	Assembly, Turret (See Group 70, Figure 01 for NHA)					Ref
2	802072	• Weldment, Turret					1
3	W-103646	• Screw					4
4	802039	• Ring, First Boom Pin Threaded					2
5	802020	• Pin, First Boom Hollow					2
6	W-106664	• Screw					8
7	W-101976	• Washer, Elastic					8
8	W-106654	• Screw					1
9	W-102070	• Washer, Elastic					1
10	802045	• Washer, Pin					1
11	802021	• Pin, Pivot					1
12	W-100805	• Nipple, Grease					1
13	C-VC130.2225C6	• Screw					48
14	C-UE110.22	• Washer					48
15	C-VD113.2225	• Nut					48

DASH (-) ITEM NOT ILLUSTRATED

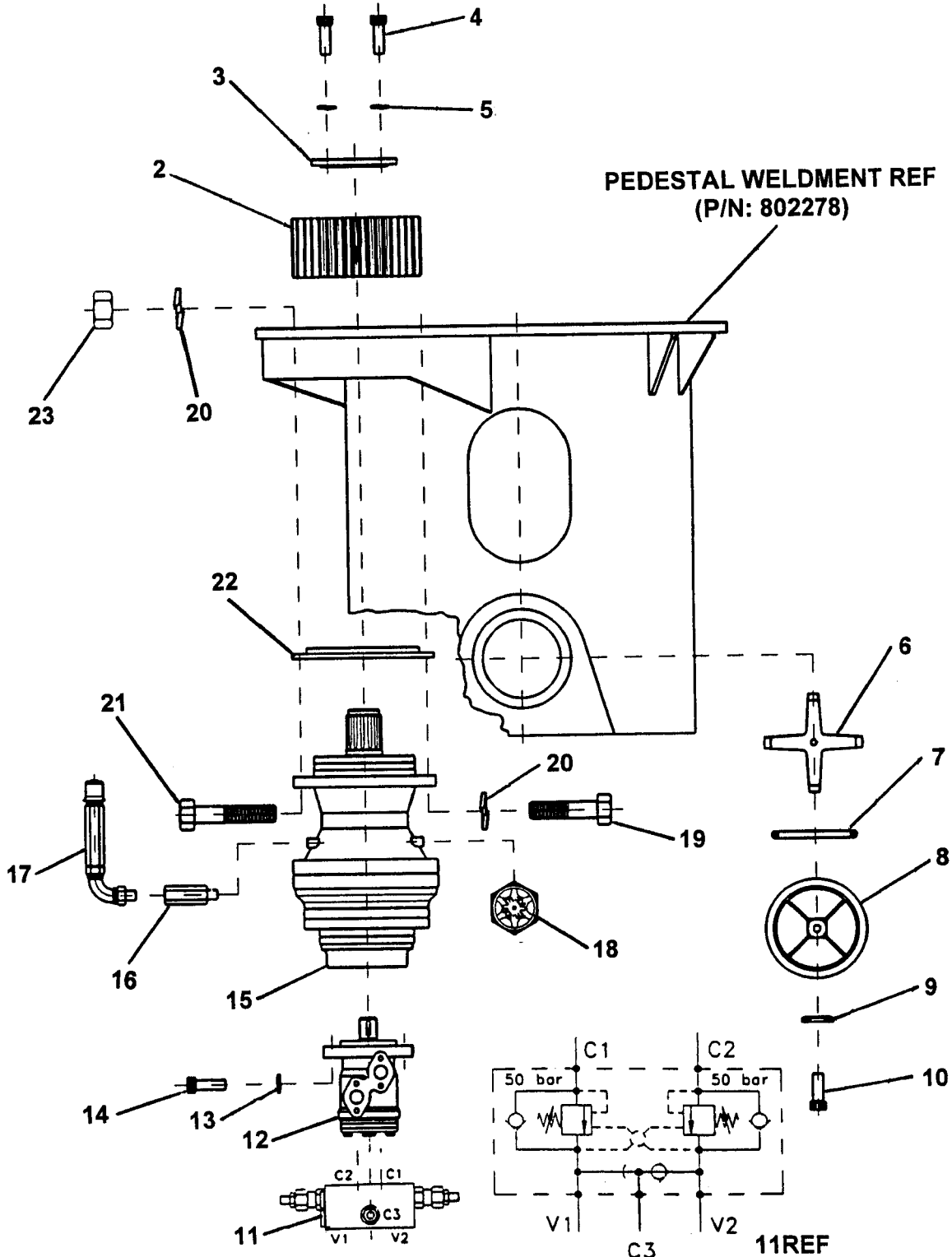
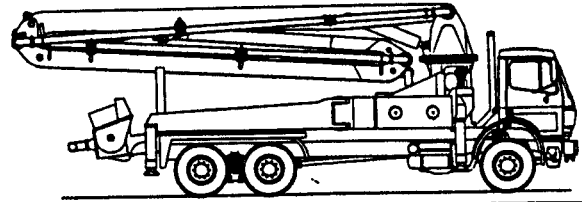
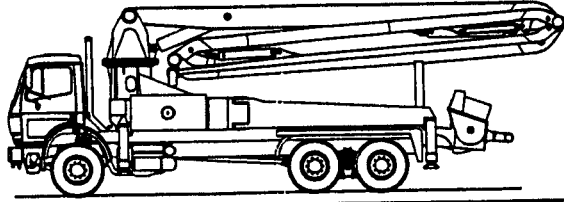

REED**MOTOR AND REDUCTION ASSEMBLY****XT 36**
PARTS
GROUP 70
FIGURE 03
PAGE 02

ITEM NO.	REED'S PARTS NO.	DESCRIPTION					QTY
		1	2	3	4	5	
-1	C-8G1	Assembly, Motor And Reduction (See Group 70, Figure 01 for NHA)					Ref
2	802074	• Gear, Pinion					1
3	802078	• Washer, Pinion					1
4	C-VC110.101530	• Screw					3
5	C-UE110.10	• Washer, Elastic					3
6	802085	• Support, Tank Cover Star					1
7	802086	• O-Ring, Tank Cover					1
8	802084	• Cover, Tank					1
9	802087	• Washer, Tank Cover Sealing					1
10	C-VC110.162040	• Screw					1
11	802077	• Valve, Over Center Rotation					1
12	802076	• Assembly, Rotation Hydraulic Motor					1
13	C-UE110	• Washer, Elastic					4
14	C-VC110	• Screw					4
15	802075	• Reducer, Rotation Gear					1
16	C-NP020.040MF	• Fitting					1
17	802082	• Breather					1
18	802083	• Gage, Oil Level					1
19	C-VE110.162055	• Screw					3
20	C-UE110.16	• Washer, Elastic					10
21	C-VE110.162075	• Screw					3
22	802079	• Flange, Pinion Adjustment					1
23	C-VD111.1620	• Nut					7

DASH (-) ITEM NOT ILLUSTRATED

REVISION:



ROTATION UNIT ASSEMBLY

XT 36
PARTS
GROUP 70
FIGURE 04
PAGE 01

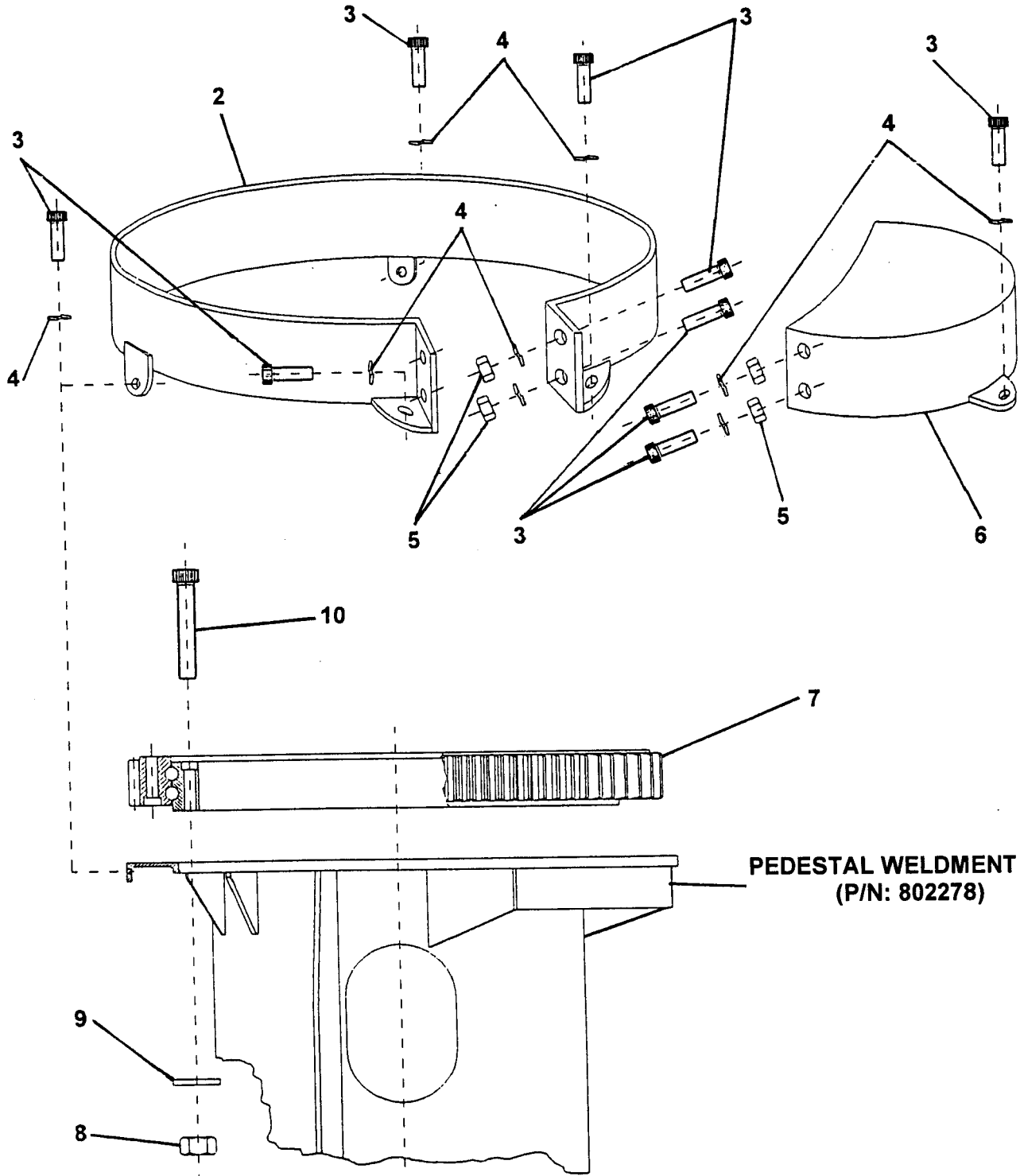
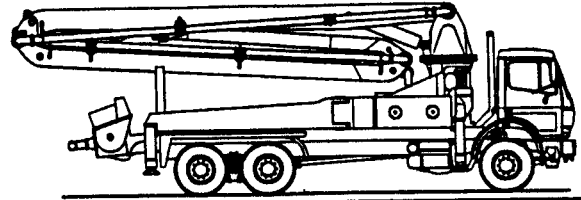
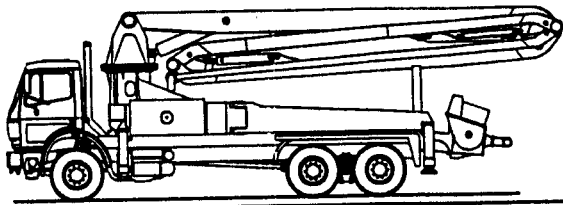

REED**ROTATION UNIT ASSEMBLY****XT 36**
PARTS
GROUP 70
FIGURE 04
PAGE 02

ITEM NO.	REED'S PARTS NO.	DESCRIPTION					QTY
		1	2	3	4	5	
-1	C-8G2	Assembly, Rotation Unit (See Group 70, Figure 01 for NHA)					Ref
2	802080	• Cover, Rotation Bearing					1
3	C-VC110.081525	• Screw					9
4	C-UE110.08	• Washer, Elastic (attaching parts)					9
5	C-VD111.0812	• Nut					4
6	802081	• Cover, Rotation Pinion					1
7	802073	• Bearing, Rotation					1
8	C-VD113.2225	• Nut (attaching parts)					48
9	C-UP110.22	• Washer (attaching parts)					48
10	C-VC130.2225C6	• Screw (attaching parts)					48

DASH (-) ITEM NOT ILLUSTRATED

REVISION:

REED

SUPPORT FRAM ASSEMBLY

XT 36
PARTS
GROUP 70
FIGURE 05
PAGE 01

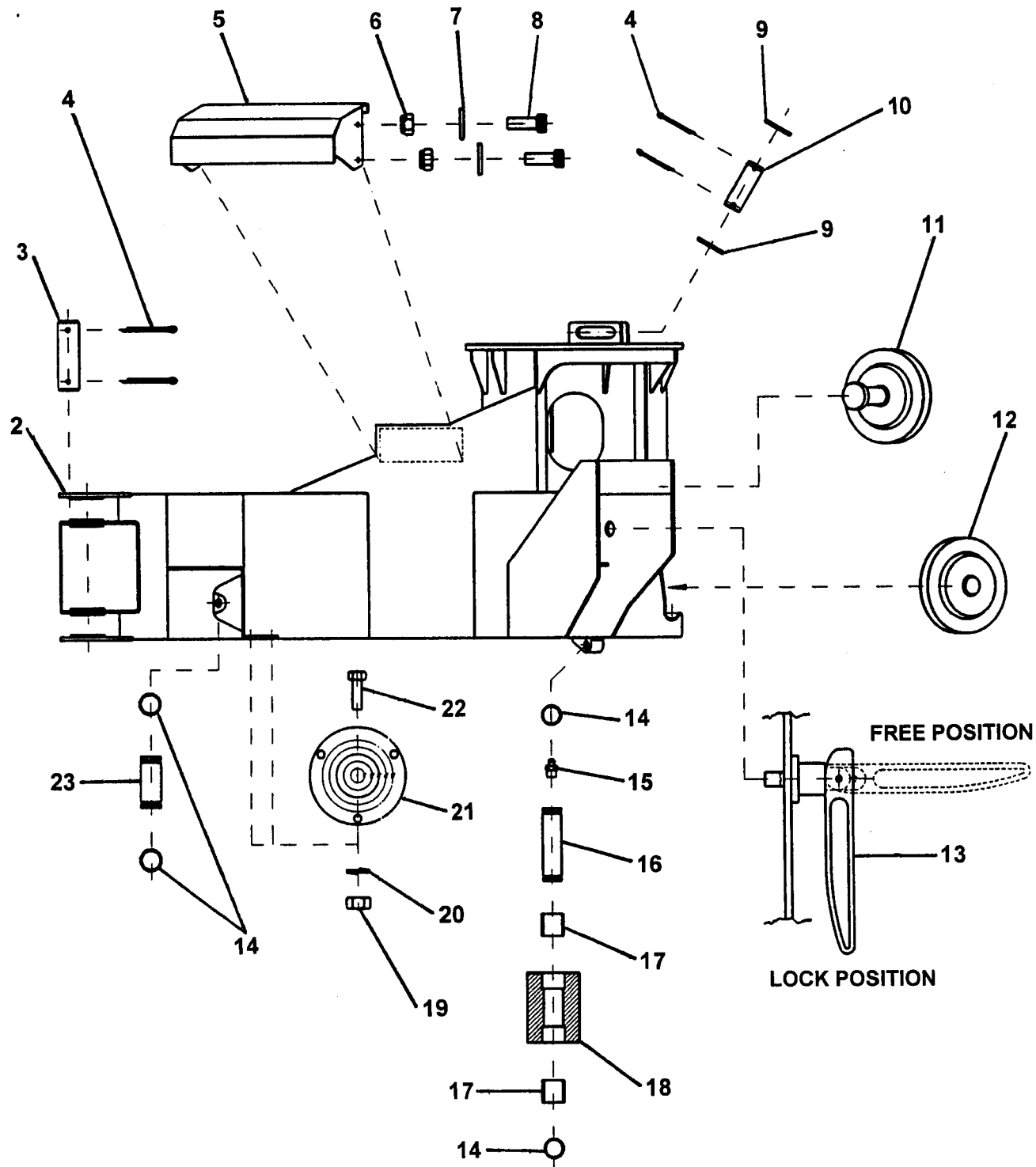
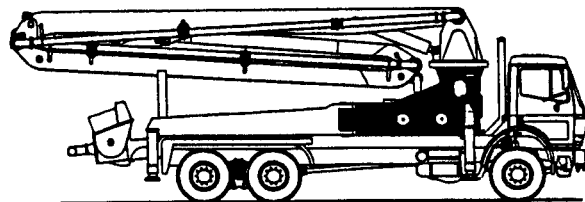
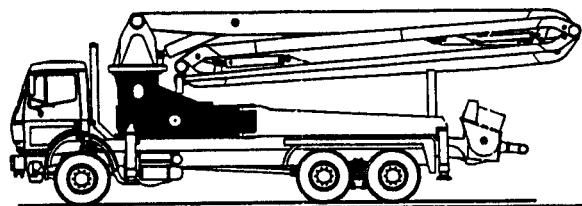

ITEM NO.	REED'S PARTS NO.	DESCRIPTION					QTY
		1	2	3	4	5	
-1	802102	Assembly, Pedestal (See Group 70, Figure 01 for NHA)					Ref
2	802278	• Weldment, Pedestal					1
3	802115	• Pin, Swing Out Cylinder					6
4	C-VS110.08070	• Pin, Split					14
5	C-1H106	• Cover, Distributor					1
6	C-VD111.0812	• Nut, Self Locking					4
7	C-UP110.08	• Washer					4
8	C-VC110.081225	• Screw					4
9	802124	• Washer, Rotation Stop					2
10	802114	• Pin, Rotation Stop					1
11	802130	• Assembly, Right Hand Side Hose Reel (See Group 70, Figure 11 for DET)					1
12	802129	• Reel, Left Hand Side Hose					1
13	802131	• Lock, Outtrigger					1
14	C-AA110.025	• Ring, Clamping					1
15	C-VI131.0608	• Nipple, Grease					2
16	802118	• Pin, Bottom Extended Roller					2
17	802125	• Bearing					4
18	802121	• Roller, Bottom Extended					2
19	C-VD111.0407	• Nut					3
20		• Screw					
21	C-LL401	• Level					1
22	C-VS110.040715	• Pin, Split					3
23	802116	• Pin, Extend Cylinder					2

DASH (-) ITEM NOT ILLUSTRATED

REED

FRONT STABILIZERS TELESCOPIC LEG ASSEMBLY

XT 36
PARTS
GROUP 70
FIGURE 06
PAGE 01

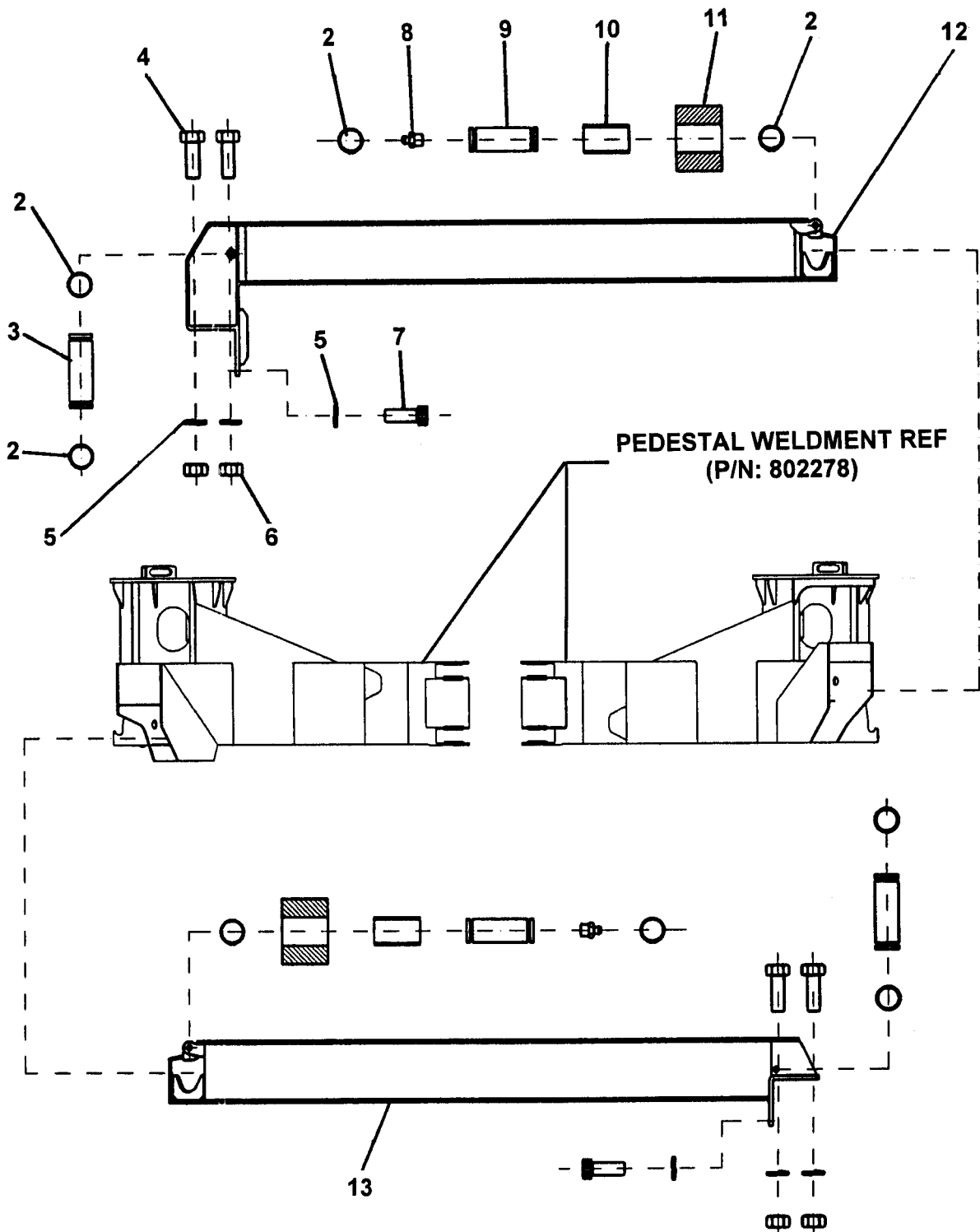
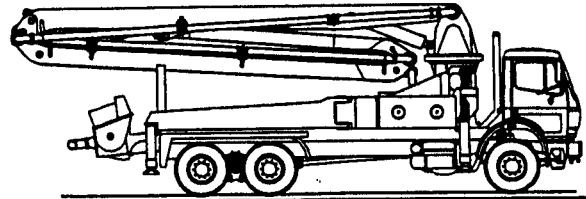
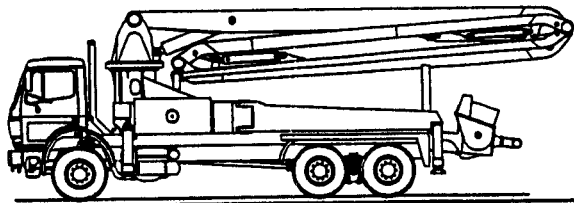

REED**FRONT OUTRIGGER GROUP ASSEMBLY****XT 36**
PARTS
GROUP 70
FIGURE 06
PAGE 02

ITEM NO.	REED'S PARTS NO.	1 2 3 4 5	DESCRIPTION	QTY
-1	802105		Assembly, Front Outrigger Group (See Group 70, Figure 01 for NHA)	Ref
2	C-AA110.025		• Ring, Clamping	8
3	802116		• Pin, Extend Cylinder	2
4	C-VE110.222580		• Screw	8
5	C-UE110.22		• Washer, Elastic	12
6	C-VD111.2225		• Nut	8
7	C-VC110.222550		• Screw	4
8	C-VI131.1010		• Nipple, Grease	2
9	802119		• Pin, Top Extend Roller	2
10	802126		• Bearing	2
11	802122		• Roller, Top Extend Outrigger	2
12	802107		• Weldment, Right Front Outrigger	1
13	802108		• Weldment, Left Front Outrigger	1

DASH (-) ITEM NOT ILLUSTRATED

REVISION:

REED

REAR SWING OUT LEG ASSEMBLY

XT 36
PARTS
GROUP 70
FIGURE 07
PAGE 01

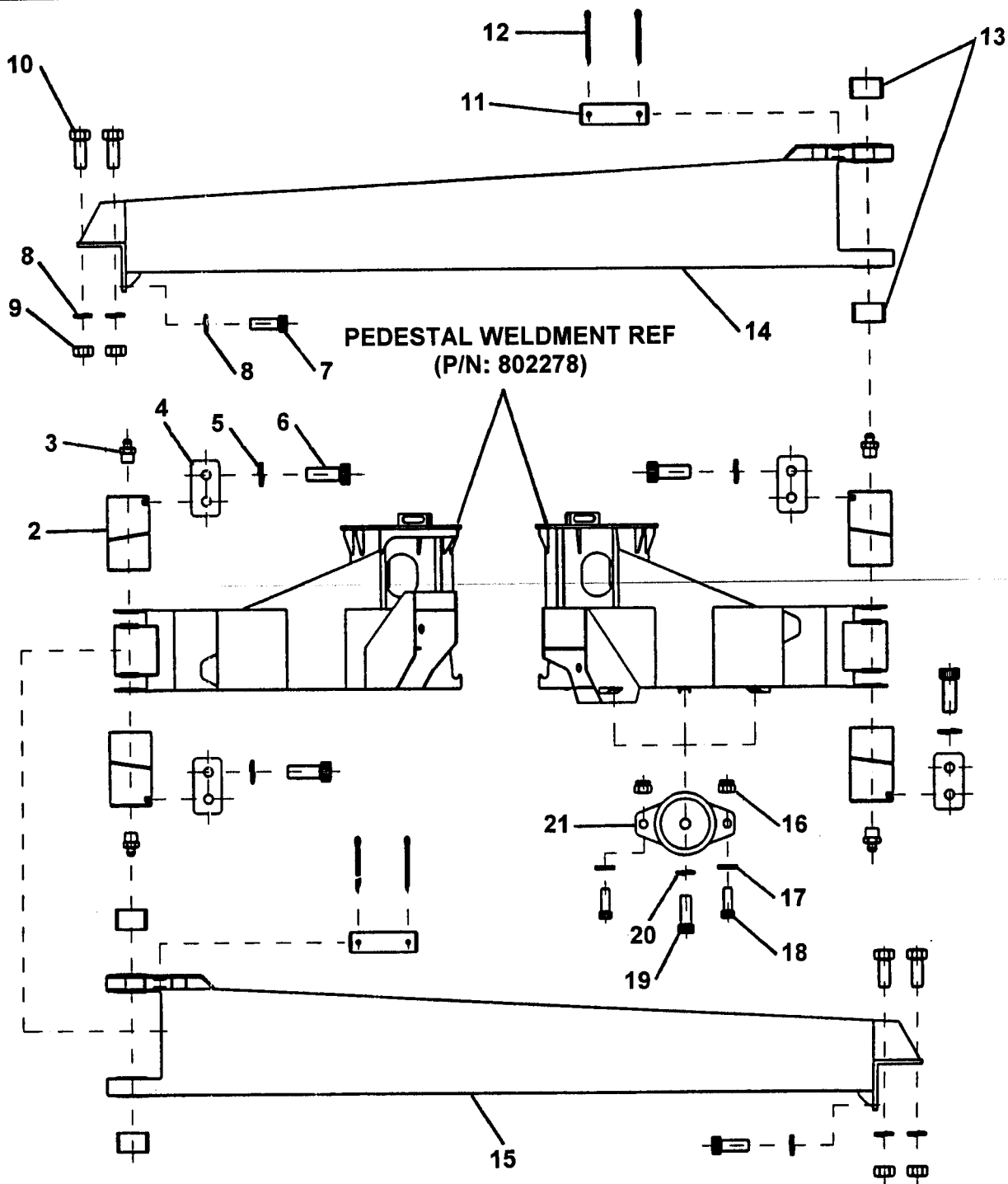
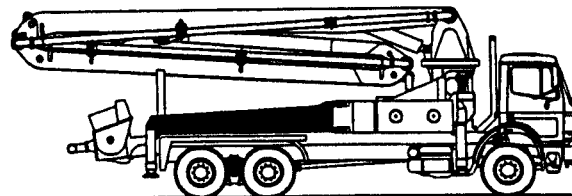
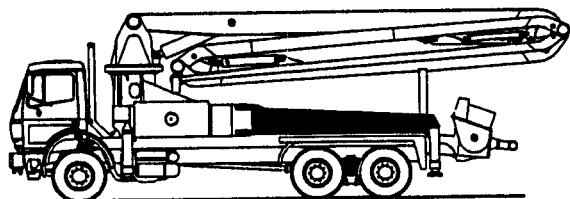



REAR OUTRIGGER GROUP ASSEMBLY

XT 36
PARTS
GROUP 70
FIGURE 07
PAGE 02

ITEM NO.	REED'S PARTS NO.	DESCRIPTION					QTY
		1	2	3	4	5	
-1	802106	Assembly, Rear Outrigger Group (See Group 70, Figure 01 for NHA)					Ref
2	802120	• Pin, Rear Outrigger					4
3	C-VI131.1010	• Nipple, Grease					2
4	802123	• Plate, Outrigger Pin Retainer					4
5	C-UE110.12	• Washer, Elastic					8
6	C-VC110.121730	• Screw					8
7	C-VC110.222550	• Screw					4
8	C-UE110.22	• Washer, Elastic					12
9	C-VD111.2225	• Nut					12
10	C-VE110.222580	• Screw					8
11	802115	• Pin, Swing Out Cylinder					2
12	C-VS110.08070	• Pin, Split					4
13	802127	• Bearing					4
14	802110	• Weldment, Left Rear Outrigger					1
15	802109	• Weldment, Right Rear Outrigger					1
16	C-VC110.081225	• Screw					6
17	C-UP110.08	• Washer					6
18	C-VD221.0812	• Nut, Self Locking					6
19	C-VC110.101530	• Screw					3
20	C-UE110.10	• Washer, Elastic					3
21	C-UG317.30100	• Block, Silent					3

DASH (-) ITEM NOT ILLUSTRATED

REVISION:

FRONT TELESCOPIC LEG CYLINDER ASSEMBLY

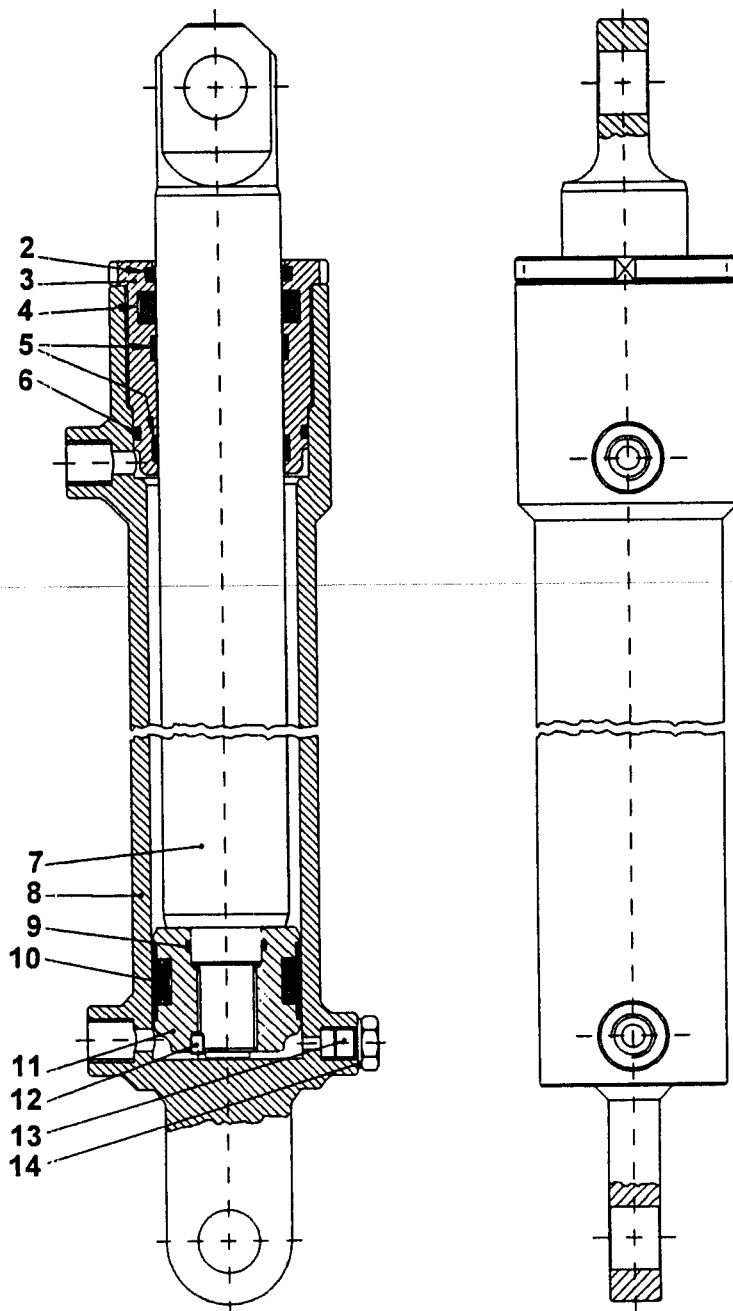
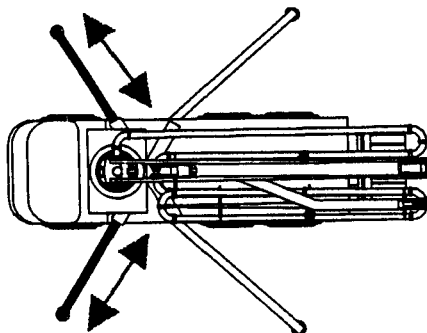

REED**OUTRIGGER EXTEND
CYLINDER ASSEMBLY****XT 36****PARTS**

GROUP 70

FIGURE 08

PAGE 02

ITEM NO.	REED'S PARTS NO.	DESCRIPTION					QTY
		1	2	3	4	5	
-1	802112	Assembly, Outrigger Extend Cylinder (See Group 70, Figure 01 for NHA)					Ref
2	C-BR310.050	• Gasket, Seal					1
3	C-8K401	• Head, Slide Rod					1
4	C-BT110.050	• Gasket, Seal					1
5	C-AG122.050	• Ring, Slide Rod					2
6	C-AO120.230	• Ring, Sealing					1
7	C-8K407	• Rod					1
8	C-8K402	• Cylinder					1
9	C-AO120.121	• Ring, Sealing					1
10	C-BS23236173	• Gasket, Seal					1
11	C-4K412	• Piston					1
12	C-VG121.061008	• Screw					1
13	DT101	• Plug, Drain					1
14	UP400.13	• Washer, Copper					1

DASH (-) ITEM NOT ILLUSTRATED

REVISION:

REED

STABILIZER VERTICAL JACK CYLINDER ASSEMBLY

XT 36
PARTS
GROUP 70
FIGURE 09
PAGE 01

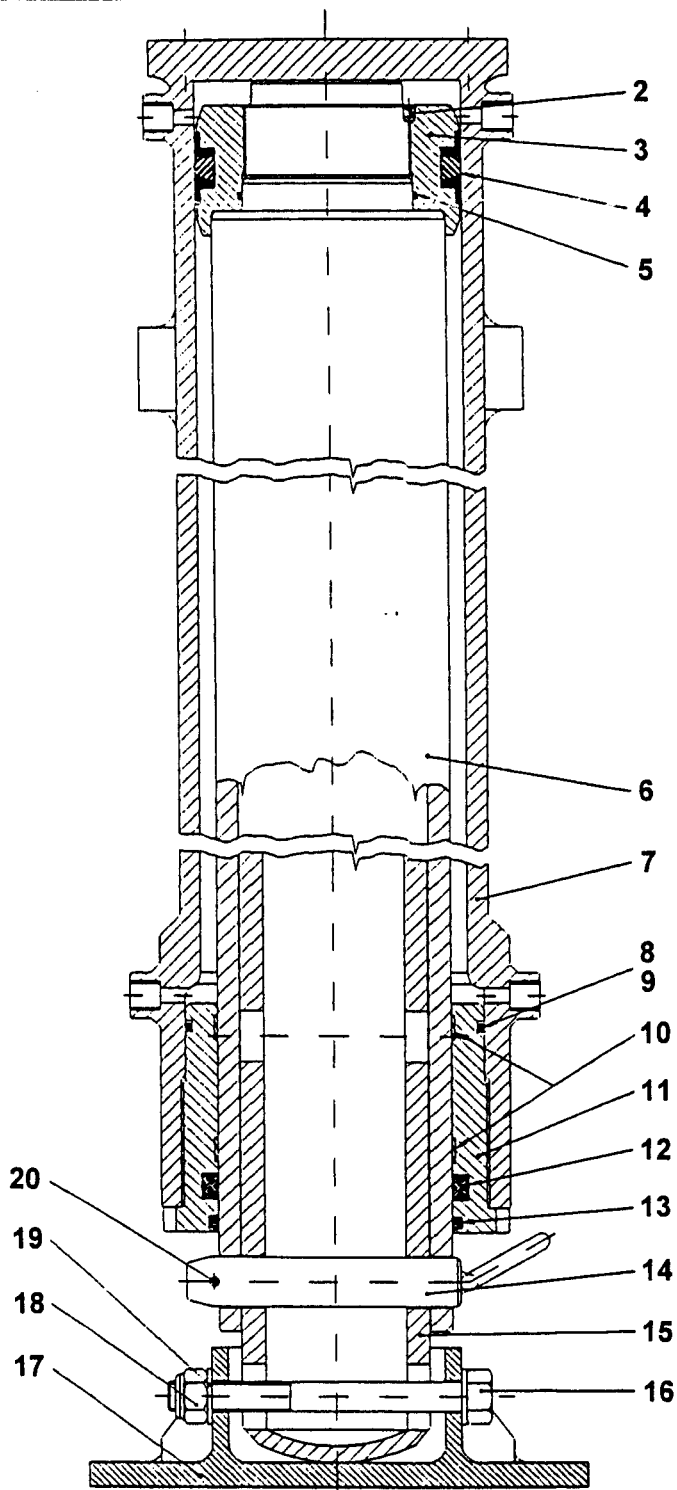
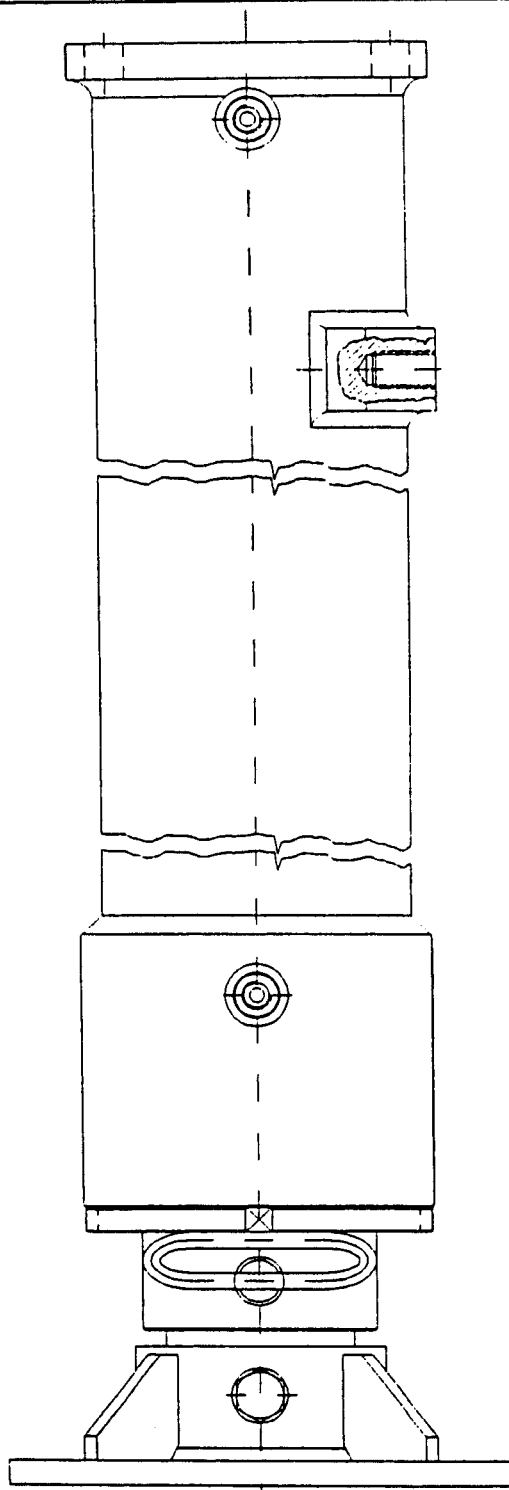
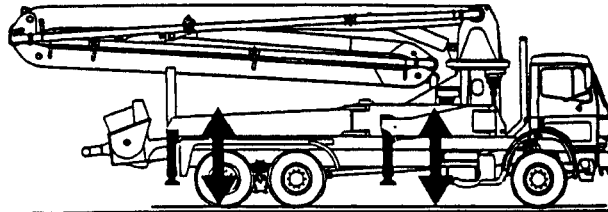
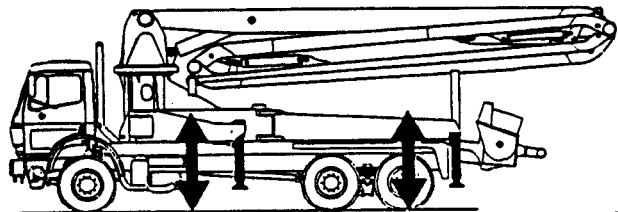



OUTRIGGER JACK CYLINDER ASSEMBLY

XT 36
PARTS
GROUP 70
FIGURE 09
PAGE 02

ITEM NO.	REED'S PARTS NO.	DESCRIPTION					QTY
		1	2	3	4	5	
-1	802404	Assembly, Outrigger Jack Cylinder (See Group 70, Figure 01 for NHA)					Ref
2	C-VG122.081010	• Screw					1
3	C-3K512	• Piston					1
4	C-BS23629531	• Gasket, Seal					1
5	C-AO102.242	• Gasket, Seal					1
6	C-1L507	• Rod					1
7	C-3L502B	• Cylinder					1
8	C-AO120.364	• Gasket, Seal					1
9	C-AP110.364	• Gasket, Seal					1
10	C-AG123.140	• Ring, Slide Rod					2
11	C-3K501	• Head, Slide Rod					1
12	C-BT110.140	• Gasket, Seal					1
13	C-BR310.140	• Gasket, Seal					1
14	C-1L520	• Pin, Check					1
15	C-1L517	• Rod, Manually Operated					1
16	C-VE110.1825C8	• Screw, Foot					1
17	C-6K519	• Foot					1
18	C-VD221.1825	• Nut, Self Locking					1
19	C-UP110.18	• Washer, Elastic					2
20	C-VS110.06040	• Pin, Split					1

DASH (-) ITEM NOT ILLUSTRATED

REVISION:

REED

REAR SWING OUT CYLINDER ASSEMBLY

XT 36
PARTS
GROUP 70
FIGURE 10
PAGE 01

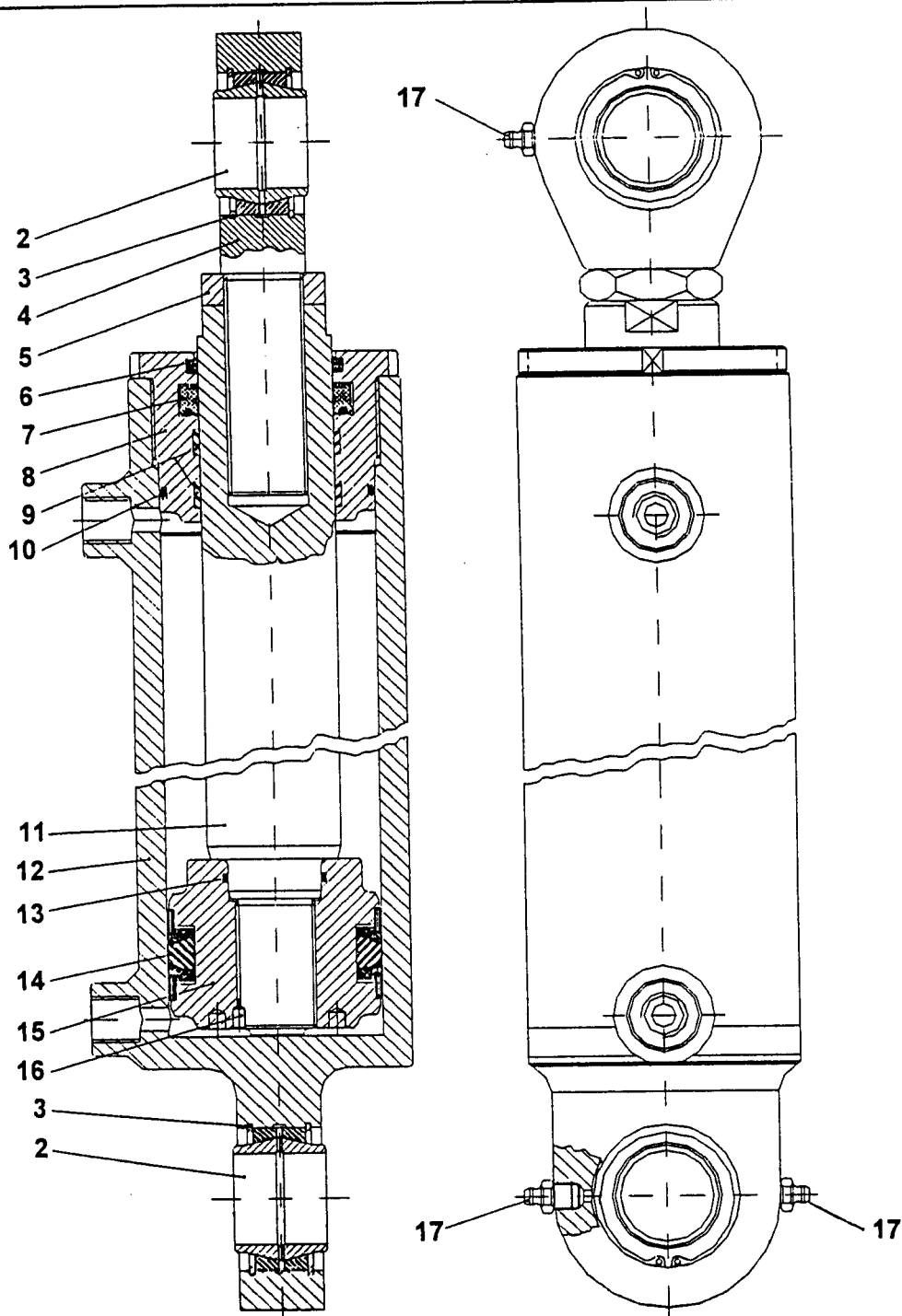
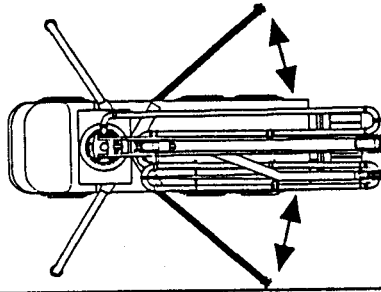

ITEM NO.	REED'S PARTS NO.	DESCRIPTION					QTY
		1	2	3	4	5	
-1	802113	Assembly, Swing Out Cylinder (See Group 70, Figure 01 for NHA)					Ref
2	C-CT223.035	• Joint, Ball					2
3	C-AA120.055	• Ring, Clamping					4
4	C-8M308	• Cap, Rod					1
5	C-3M325	• Nut					1
6	C-BR210.196228	• Gasket, Seal					1
7	C-BT110.050	• Gasket, Seal					1
8	C-3M301	• Head, Slide Rod					1
9	C-AG122.050	• Ring, Slide Rod					2
10	C-AO420.4287	• Ring, Sealing					1
11	C-8M307	• Rod					1
12	C-8M302	• Cylinder					1
13	C-AO120.126	• Ring, Sealing					1
14	C-BS23314236	• Gasket, Seal					1
15	C-1K312	• Piston					1
16	C-VG122.061008	• Screw					1
17	C-VI131.1010	• Nipple, Grease					3

DASH (-) ITEM NOT ILLUSTRATED

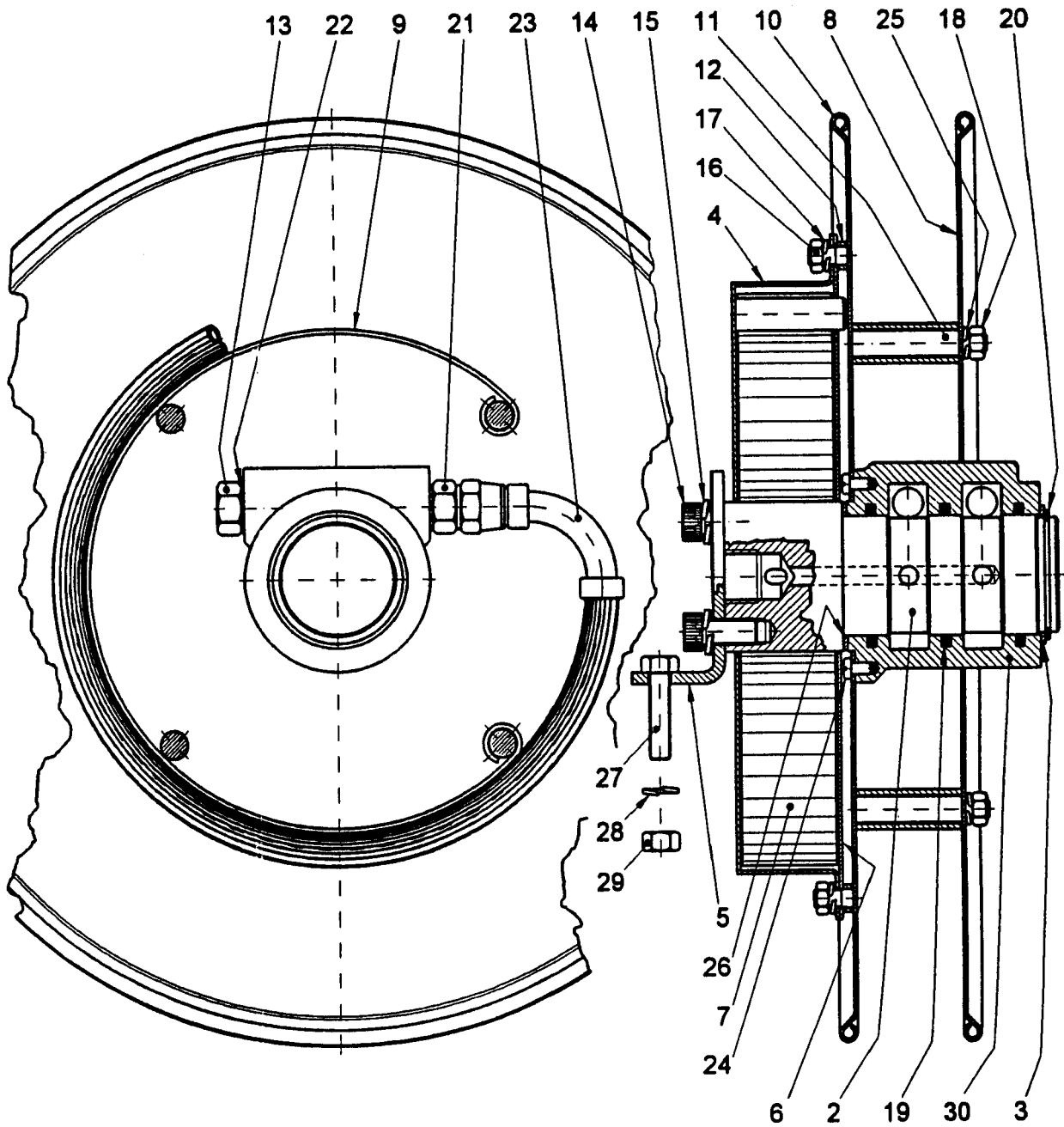
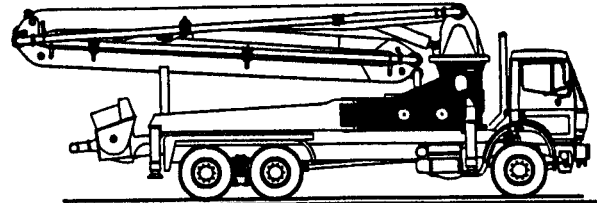
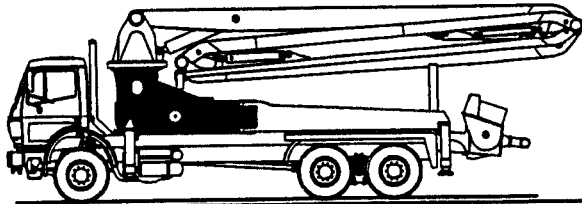



RIGHT HAND SIDE HOSE REEL ASSEMBLY

XT 36
PARTS
GROUP 70
FIGURE 11
PAGE 02

ITEM NO.	REED'S PARTS NO.	DESCRIPTION					QTY
		1	2	3	4	5	
-1	802130	Assembly, Right Hand Side Hose Reel (See Group 70, Figure 01 for NHA)					Ref
2	C-RA102.02	• Shaft					1
3	C-RA102.03	• Spacer					1
4	C-RA102.04	• Cap, Spring					1
5	C-RA102.05	• Bracket					1
6	C-RA102.06	• Separator, Spring					1
7	C-RA102.07	• Spring					1
8	C-RA102.08	• Plate, Side					1
9	C-RA102.09	• Band, Coiling					1
10	C-RA102.10	• Plate, Side Spring					1
11	C-RA102.11	• Tie-Rod					4
12	C-RA102.12	• Spacer, For Separator					4
13	C-RA102.13	• Plug					2
14	C-RA102.14	• Screw					2
15	C-RA102.15	• Washer					2
16	C-RA102.16	• Nut					4
17	C-RA102.17	• Washer					4
18	C-RA102.18	• Nut					4
19	C-RA102.19	• Ring, Sealing					3
20	C-RA102.20	• Ring, Clamping					1
21	C-RA102.21	• Fitting					2
22	C-RA102.22	• Washer, Copper					4
23		• Hose, Flexible					1
24	C-RA102.24	• Screw					4
25	C-RA102.25	• Washer					4
26	C-RA102.26	• Spacer					1
27	C-RA102.27	• Screw					2
28	C-RA102.28	• Washer, Elastic					2
29	C-RA102.29	• Nut					2
30	C-RA102.01	• Bearing					1

DASH (-) ITEM NOT ILLUSTRATED

REVISION:

OUTRIGGER HOLDING VALVE ASSEMBLY

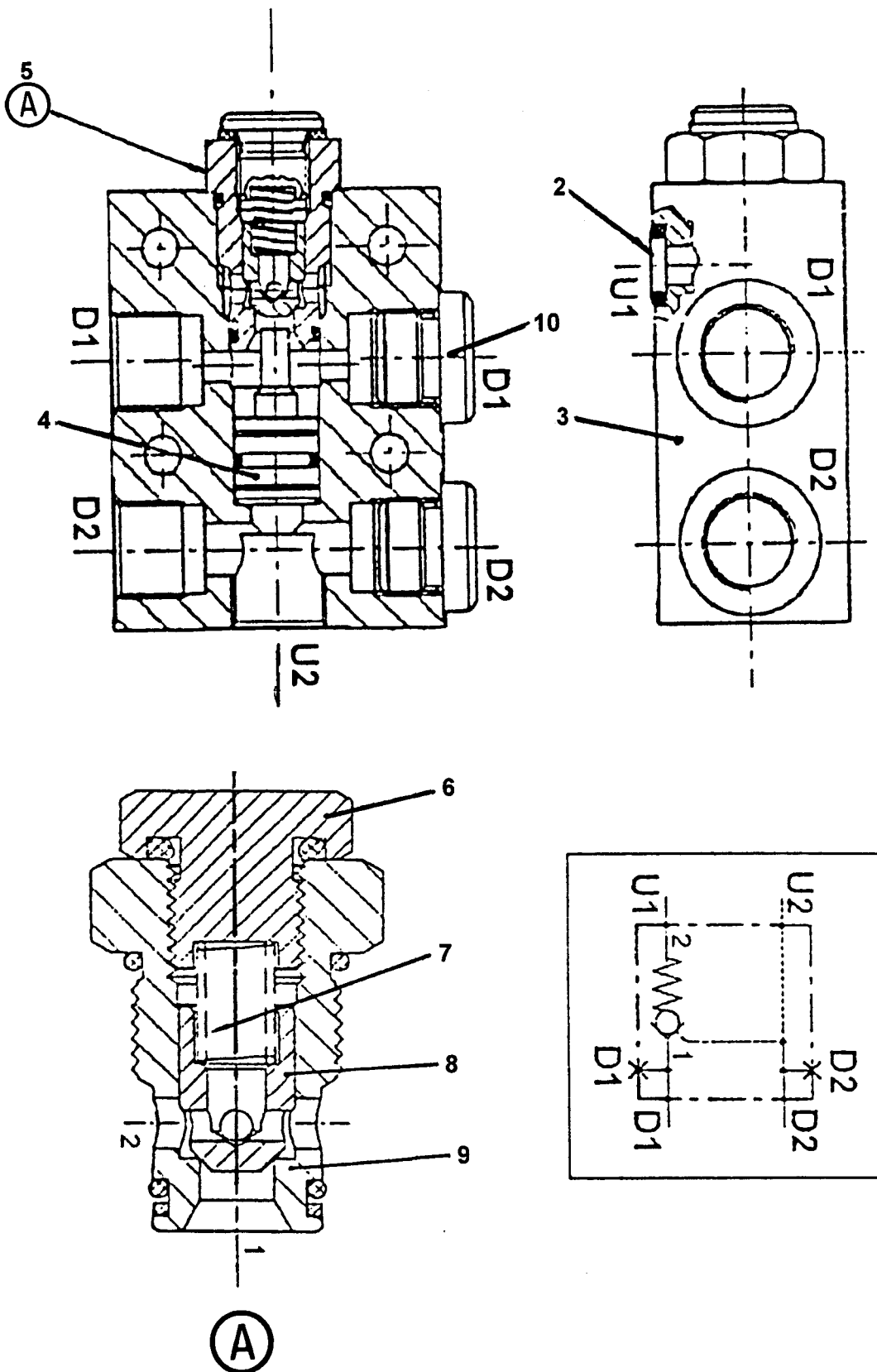

ITEM NO.	REED'S PARTS NO.	DESCRIPTION					QTY
		1	2	3	4	5	
-1	802144	Assembly, Outrigger Holding Valve (See Group 70, Figure 01 for NHA)					Ref
2	C-WD201.01	• O-Ring					1
3	C-WD201.03	• Body, Outrigger Holding Valve					1
4	C-WD201.04	• Piston					1
5	C-WD201.05	• Valve, Holding (Complete Element)					1
6	C-WD201.05.3	• • Plug, Screw					1
7	C-WD201.05.4	• • Spring					1
8	C-WD201.05.2	• • Nozzle					1
9	C-WD201.05.1	• • Body, Element					1
10	C-WD201.02	• Plug, Screw					2

DASH (-) ITEM NOT ILLUSTRATED



**TRUCK MOUNTED CONCRETE PUMP XT36
ILLUSTRATED PARTS MANUAL**

**XT 36
PARTS
GROUP 70
FIGURE 13
PAGE 01**

THIS PAGE INTENTIONALLY LEFT BLANK.

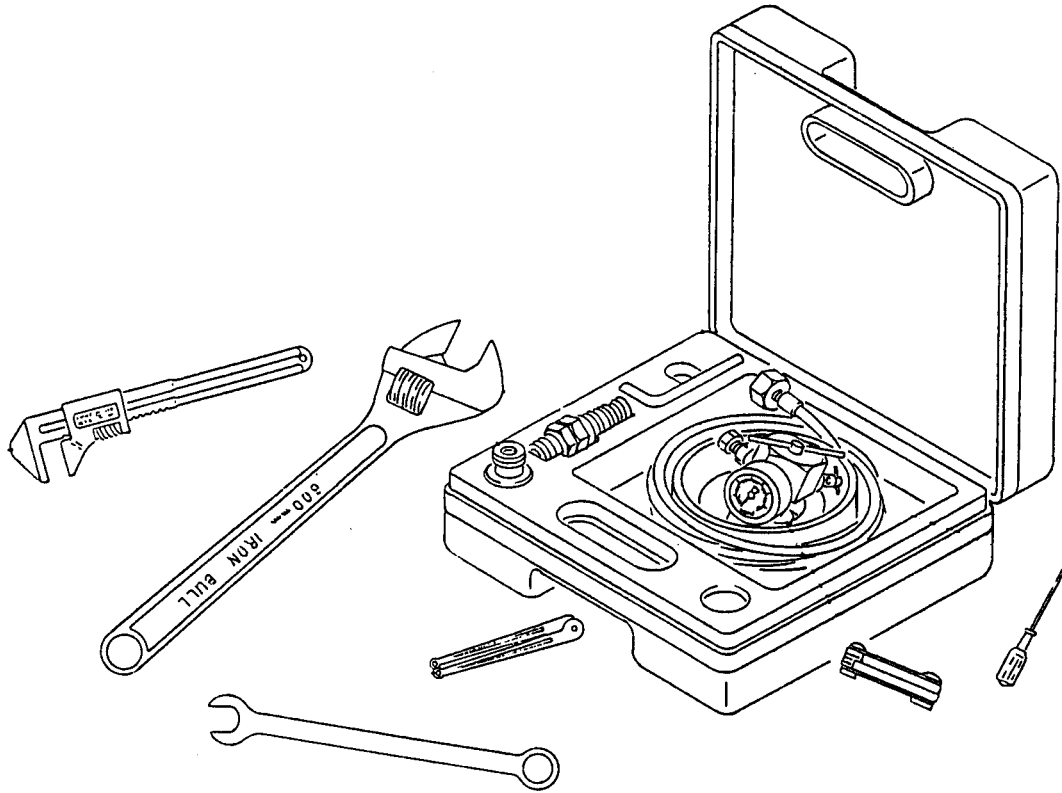

REED TRUCK MOUNTED CONCRETE BOOM PUMP MODEL XT 36 ILLUSTRATED PARTS MANUAL GROUP 80 OPTIONAL INSTALLATION CONTAINS THE FOLLOWING FIGURES:

- FIGURE 00** TABLE OF CONTENTS
- FIGURE 01** OPTIONAL INSTALLATION
- FIGURE 02** ACCUMULATOR CHARGE KIT
- FIGURE 03** OPTIONAL TOO KIT ASSEMBLY

REED

OPTIONAL INSTALLATION

XT 36
PARTS
GROUP 80
FIGURE 01
PAGE 01

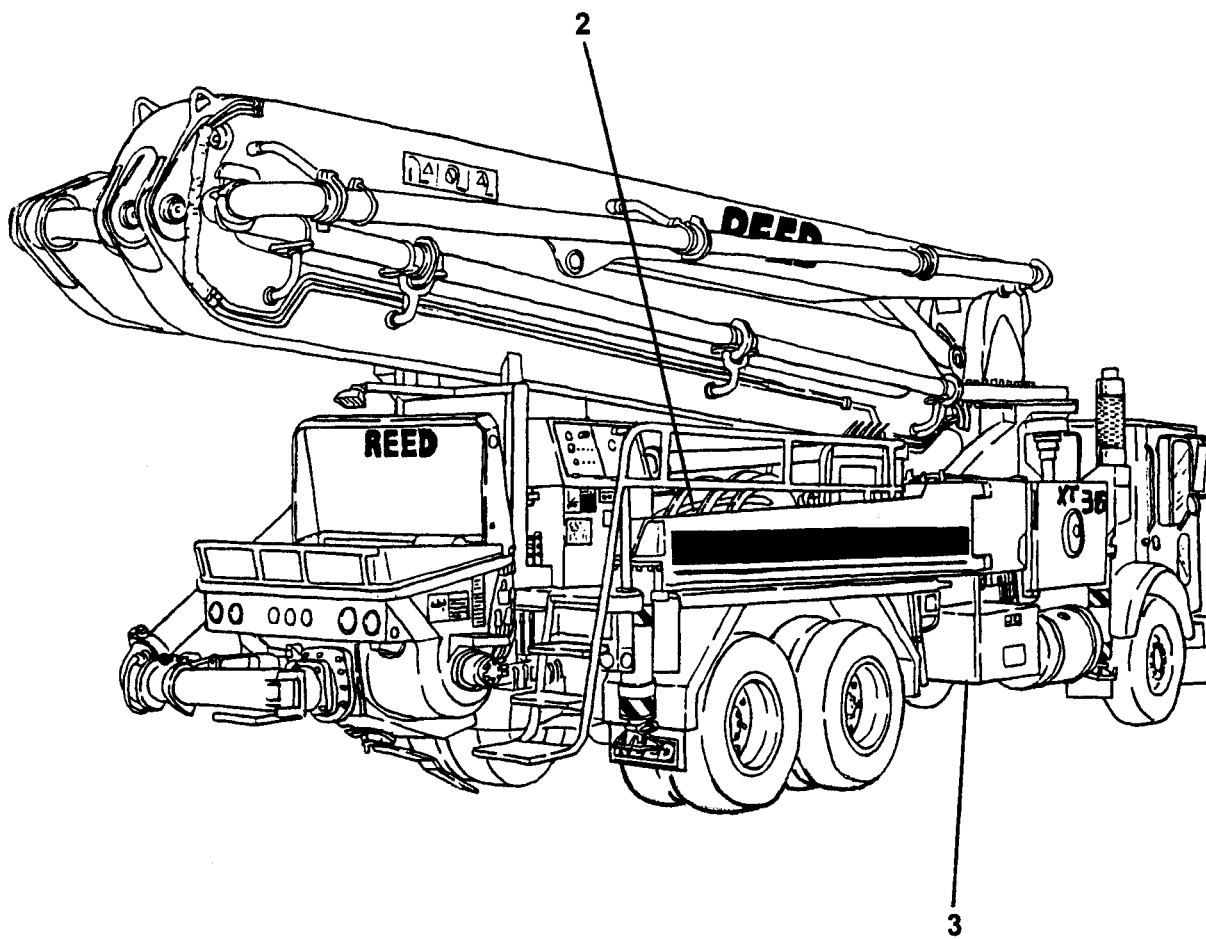

ITEM NO.	REED'S PARTS NO.	DESCRIPTION					QTY
		1	2	3	4	5	
-1	80-01	Installation, Optional (See Group 10, Figure 01 for NHA)					Ref
2	71460	• Kit, Accumulator Charge (See Group 80, Figure 04 for DET)					1
3	79020	• Assembly, Optional Tool Kit (See Group 80, Figure 06 for DET)					1

DASH (-) ITEM NOT ILLUSTRATED

REED

ACCUMULATOR CHARGE KIT

XT 36
PARTS
GROUP 80
FIGURE 02
PAGE 01

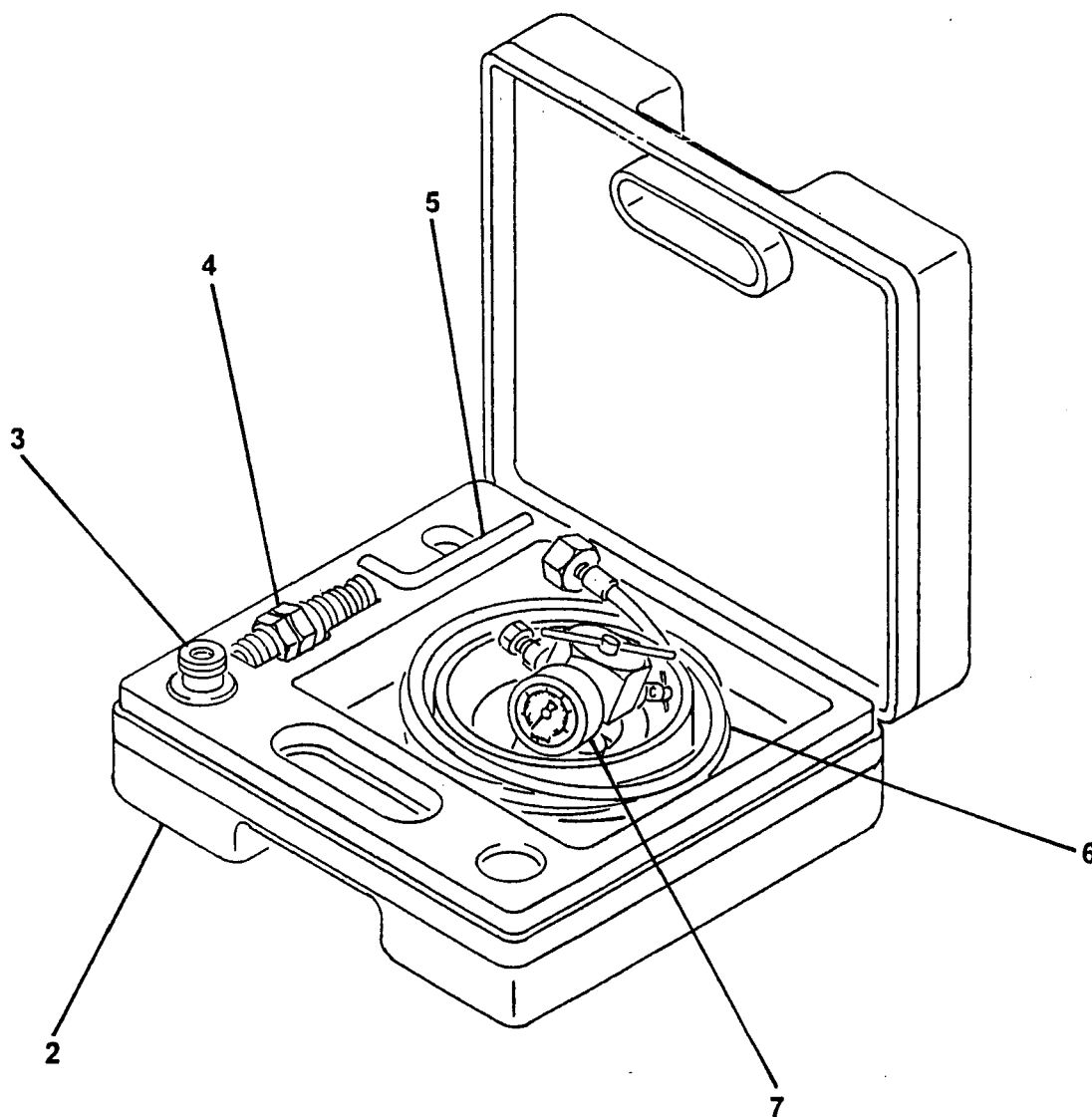

ITEM NO.	REED'S PARTS NO.	DESCRIPTION					QTY
		1	2	3	4	5	
-1	71460	Kit, Accumulator Charge (See Group 80, Figure 01 for NHA)					Ref
2		• Case, Charge Kit					1
3		• Adapter, FPK / SB					1
4		• Adapter, G4					1
5		• Wrench, Allen					1
6		• Hose, Charging					1
7		• Unit, FPK Charging and Gagging					1

DASH (-) ITEM NOT ILLUSTRATED

REED

OPTIONAL TOOL KIT ASSEMBLY

XT 36
PARTS
GROUP 80
FIGURE 03
PAGE 01

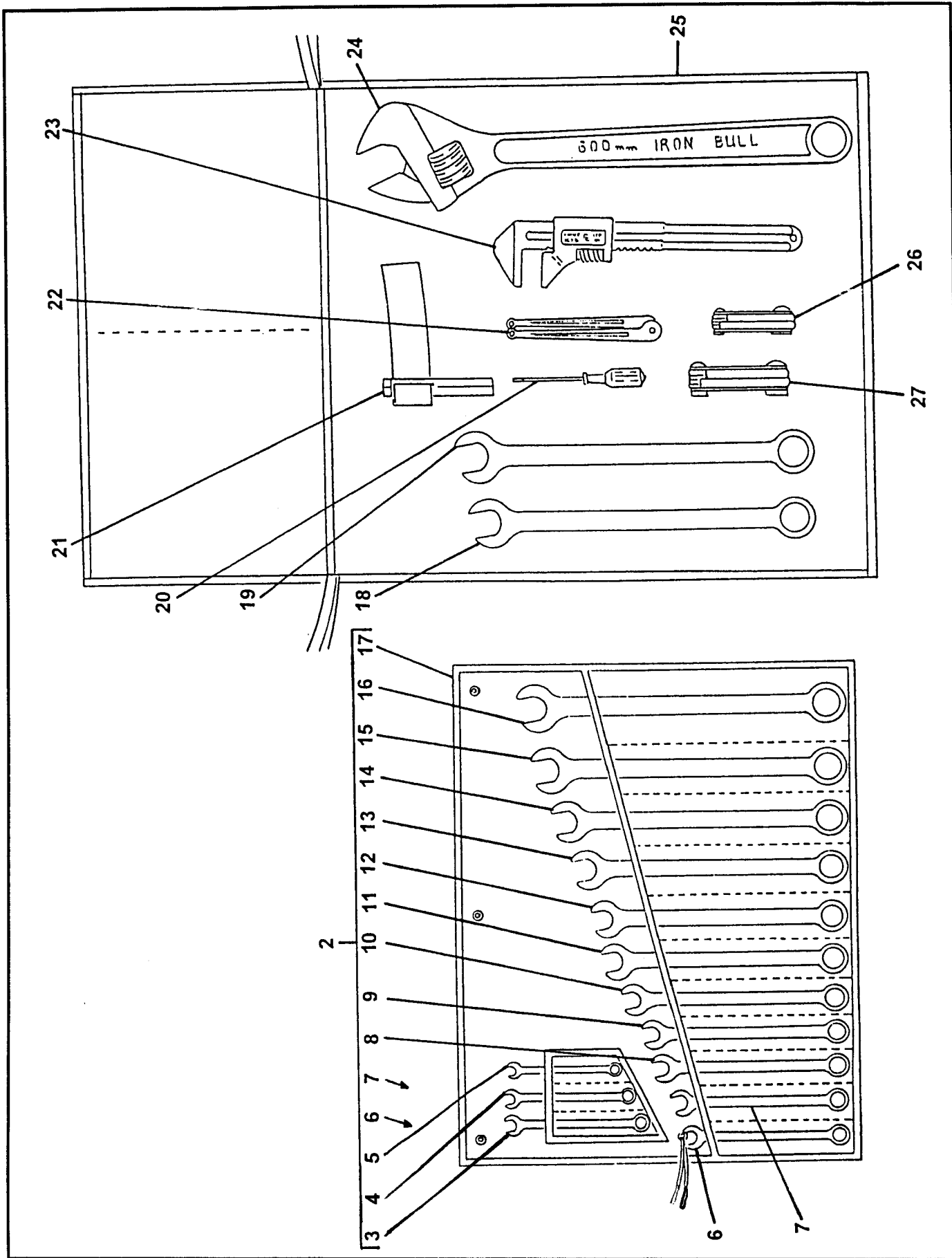

REVISION:

ITEM NO.	REED'S PARTS NO.	DESCRIPTION					QTY
		1	2	3	4	5	
-1	79020	Assembly, Optional Tool Kit (See Group 80, Figure 01 for NHA)					Ref
2	79037	• Kit, Wrench					1
3		• • Wrench, 1/2 Inch					1
4		• • Wrench, 7/16 Inch					1
5		• • Wrench, 3/8 Inch					1
6		• • Wrench, 9/16 Inch					1
7		• • Wrench, 5/8 Inch					1
8		• • Wrench, 11/16 Inch					1
9		• • Wrench, 3/4 Inch					1
10		• • Wrench, 13/16 Inch					1
11		• • Wrench, 7/8 Inch					1
12		• • Wrench, 15/16 Inch					1
13		• • Wrench, 1 Inch					1
14		• • Wrench, 1-1/16 Inch					1
15		• • Wrench, 1-1/8 Inch					1
16		• • Wrench, 1-1/4 Inch					1
17		• • Wrap, Plastic					1
18	79036	• Wrench, 1-3/8 Inch					1
19	79028	• Wrench, 1-1/2 Inch					1
20	79038	• Screwdriver					1
21	79814	• Wrench, Strap (for Filter)					1
22	79325	• Wrench, Spanner					1
23	79031	• Wrench, Monkey					1
24	79032	• Wrench, Adjustable 24 Inch					1
25	77502	• Bag, Tool					1
26	79030	• Set, Metric Allen Key (2-8 mm)					1
27	79029	• Set, Standard Allen Key (3/16-3/8 Inch)					1

DASH (-) ITEM NOT ILLUSTRATED

REED

**MODEL XT 36 TRUCK MOUNTED
CONCRETE BOOM PUMP
ILLUSTRATED PARTS MANUAL**

**XT 36
PARTS
GROUP 80
FIGURE 04
PAGE 01**

THIS PAGE INTENTIONALLY LEFT BLANK.

REED TRUCK MOUNTED CONCRETE BOOM PUMP MODEL **XT 36** ILLUSTRATED PARTS MANUAL GROUP 90 BOOM INSTALLATION CONTAINS THE FOLLOWING FIGURES:

FIGURE 00	TABLE OF CONTENTS
FIGURE 01	BOOM INSTALLATION
FIGURE 02	BOOM SECTION "A" ASSEMBLY
FIGURE 03	BOOM CYLINDER "1" ASSEMBLY
FIGURE 04	BOOM CYLINDER "2" ASSEMBLY
FIGURE 05	BOOM SECTION "B" ASSEMBLY
FIGURE 06	BOOM CYLINDER "3" ASSEMBLY
FIGURE 07	BOOM SECTION "C" ASSEMBLY
FIGURE 08	BOOM CYLINDER "4" ASSEMBLY
FIGURE 09	BOOM SECTION "D" ASSEMBLY
FIGURE 10	BOOM DELIVERY LINE ASSEMBLY
FIGURE 11	DECK DELIVERY LINE ASSEMBLY

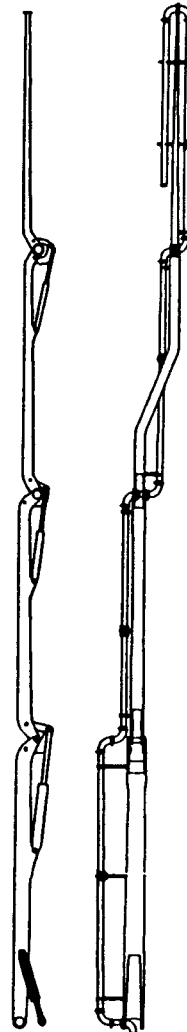
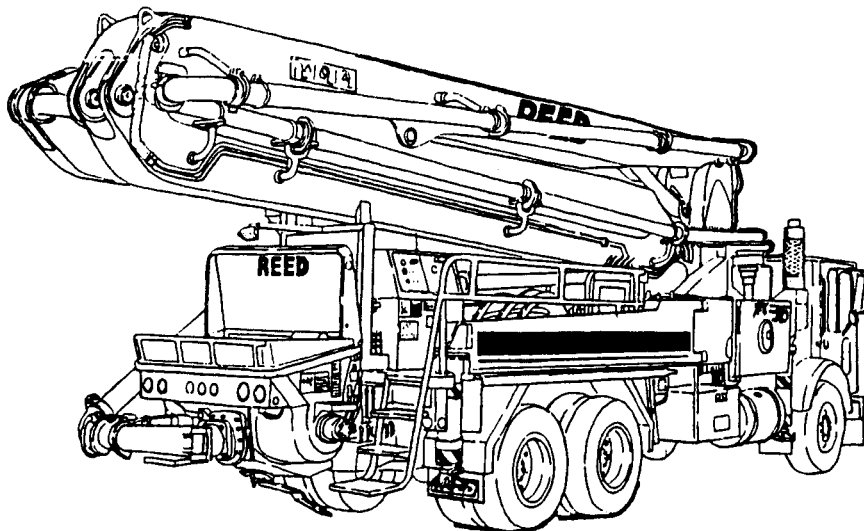

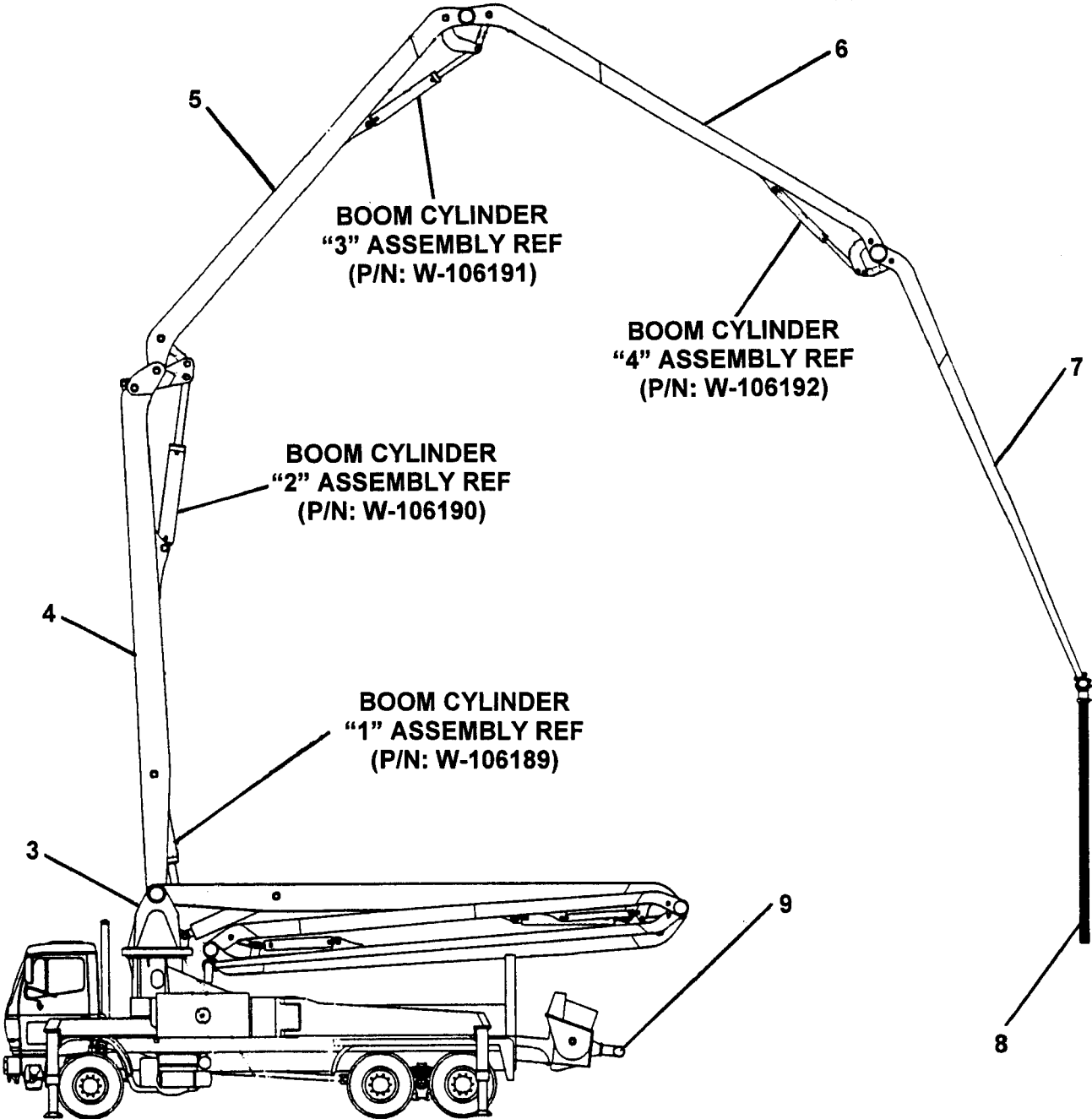

ITEM NO.	REED'S PARTS NO.	DESCRIPTION					QTY
		1	2	3	4	5	
-1	802431	Installation, Boom (See Group 10, Figure 01 for NHA)					Ref
-2	B-661011	• Installation, Boom					1
3	B-681001	• • Assembly, Turret (See Group 70, Figure 02 for DET)					
4	B-661040	• • Assembly, Boom Section "A" (See Group 90, Figure 02 for DET)					1
5	B-661050	• • Assembly, Boom Section "B" (See Group 90, Figure 05 for DET)					1
6	B-661060	• • Assembly, Boom Section "C" (See Group 90, Figure 07 for DET)					1
7	B-661070	• • Assembly, Boom Section "D" (See Group 90, Figure 09 for DET)					1
8	802159	• Assembly, Boom Delivery Line (See Group 90, Figure 10 for DET)					1
9	802293	• Assembly, Deck Delivery Line (See Group 90, Figure 11 for DET)					1

DASH (-) ITEM NOT ILLUSTRATED

REED

BOOM SECTION "A" ASSEMBLY

XT 36
PARTS
GROUP 90
FIGURE 02
PAGE 01

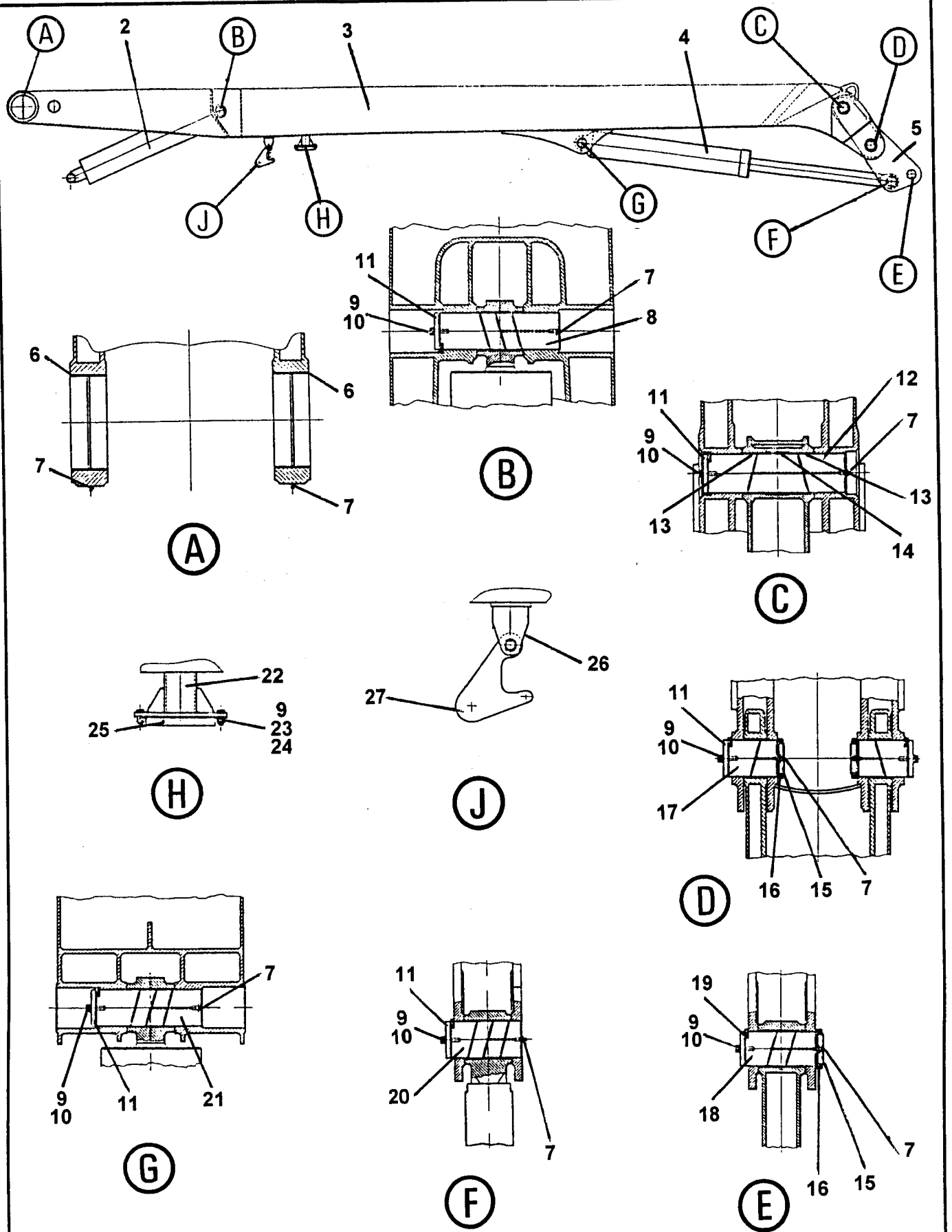

REVISION:

ITEM NO.	REED'S PARTS NO.	DESCRIPTION	QTY
-1	B-661040	Assembly, Boom Section "A" (See Group 90, Figure 01 for NHA)	Ref
2	W-106189	• Assembly, Boom Cylinder "1" (See Group 90, Figure 03 for DET)	1
3	B-671100	• Weldment, Boom Section "A"	1
4	W-106190	• Assembly, Boom Cylinder "2" (See Group 90, Figure 04 for DET)	1
5	B-671610	• Coupling, Boom "B" Beam	1
6	W-106020	• Bushing	4
7	W-100805	• Nipple, Grease	9
8	B-660053	• Pin, Pivot	1
9	W-102070	• Washer, Pin	9
10	W-106654	• Screw, Cylinder Head	7
11	B-660054	• Washer	6
12	B-660056	• Pin, Pivot	1
13	W-106019	• Bushing	2
14	B-660055	• Spacer, Pin	1
15	B-660059	• Ring, Thread Pin	3
16	W-103324	• Screw	6
17	B-660062	• Pin, Pivot	2
18	B-660057	• Pin, Pivot	1
19	B-660058	• Washer	1
20	B-660060	• Pin, Pivot	1
21	B-660061	• Pin, Pivot	1
22	B-661080	• Holder	1
23	W-101553	• Bolt, Hex	2
24	W-102125	• Nut, Hex	2
25	W-106653	• Cushion, Rubber	1
26	B-661095	• Holder	1
27	B-661096	• Hook	1

DASH (-) ITEM NOT ILLUSTRATED



BOOM CYLINDER "1" ASSEMBLY

XT 36
PARTS
GROUP 90
FIGURE 03
PAGE 01

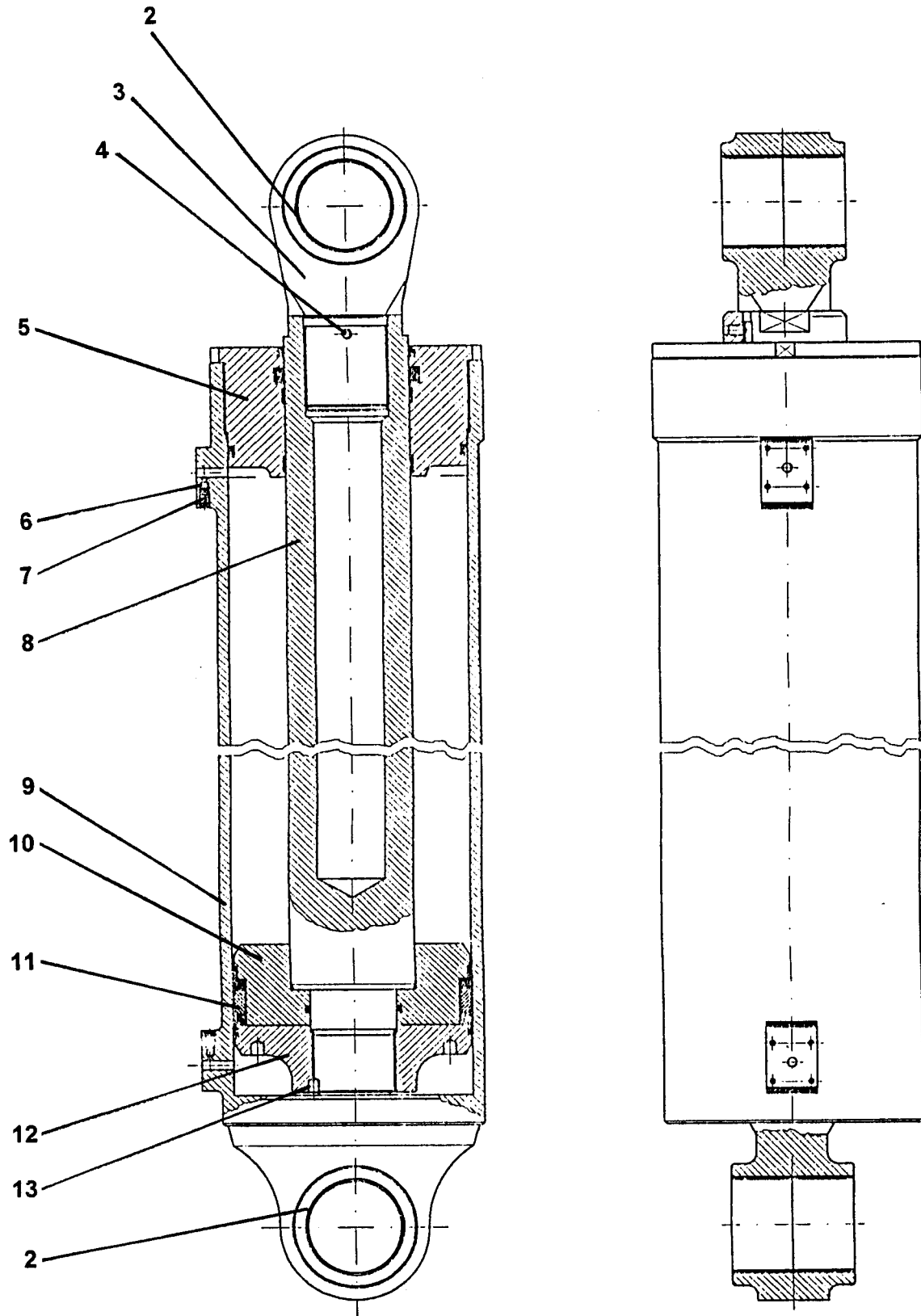

REVISION:

ITEM NO.	REED'S PARTS NO.	DESCRIPTION					QTY
		1	2	3	4	5	
-1	W-106189	Assembly, Boom Cylinder "1" (See Group 90, Figure 02 for NHA)					Ref
2	W-106018	• Bushing					4
3	W-106721	• Head, Piston					1
4	W-106725	• Screw, Set					1
5	W-106720	• Guide, Piston					1
6	W-106723	• Ball, Still					2
7	W-106722	• Valve, Air Hole					2
8	W-106719	• Rod, Piston					1
9	W-106716	• Cylinder					1
10	W-106717	• Piston					1
11	W-104033	• Kit, Seal					1
12	W-106718	• Nut, Piston					1
13	W-106724	• Screw, Set					1

DASH (-) ITEM NOT ILLUSTRATED

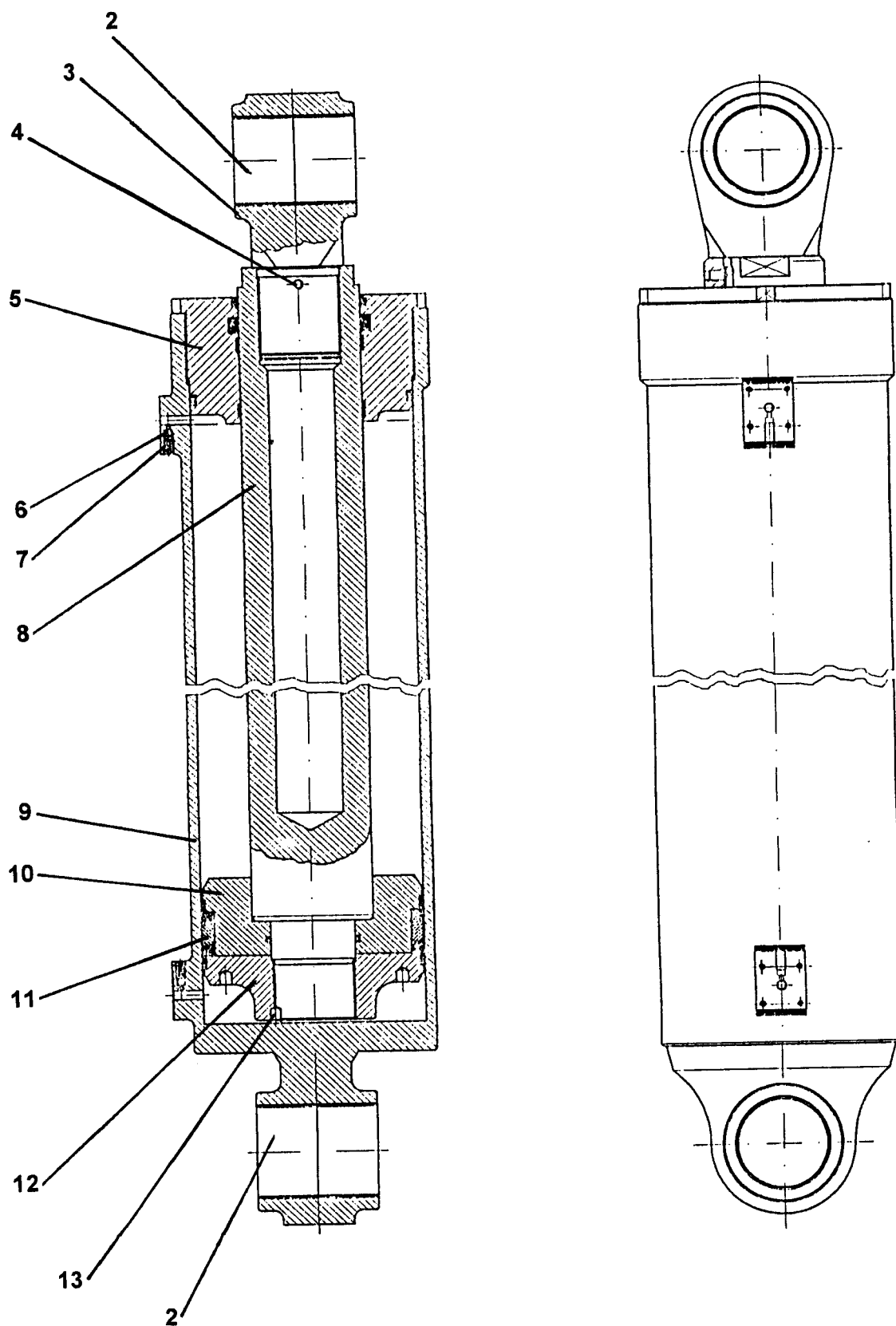



BOOM CYLINDER "2" ASSEMBLY

XT 36
PARTS
GROUP 90
FIGURE 04
PAGE 02

ITEM NO.	REED'S PARTS NO.	DESCRIPTION					QTY
		1	2	3	4	5	
-1	W-106190	Assembly, Boom Cylinder "2" (See Group 90, Figure 02 for NHA)					Ref
2	W-106018	• Bushing					4
3	W-106721	• Head, Piston					1
4	W-106725	• Screw, Set					1
5	W-106731	• Guide, Piston					1
6	W-106723	• Ball, Still					2
7	W-106722	• Valve, Air Hole					2
8	W-106730	• Rod, Piston					1
9	W-106727	• Cylinder					1
10	W-106728	• Piston					1
11	W-104034	• Kit, Seal					1
12	W-106728	• Nut, Piston					1
13	W-106724	• Screw, Set					1

DASH (-) ITEM NOT ILLUSTRATED

REED

BOOM SECTION "B" ASSEMBLY

XT 36
PARTS
GROUP 90
FIGURE 05
PAGE 01

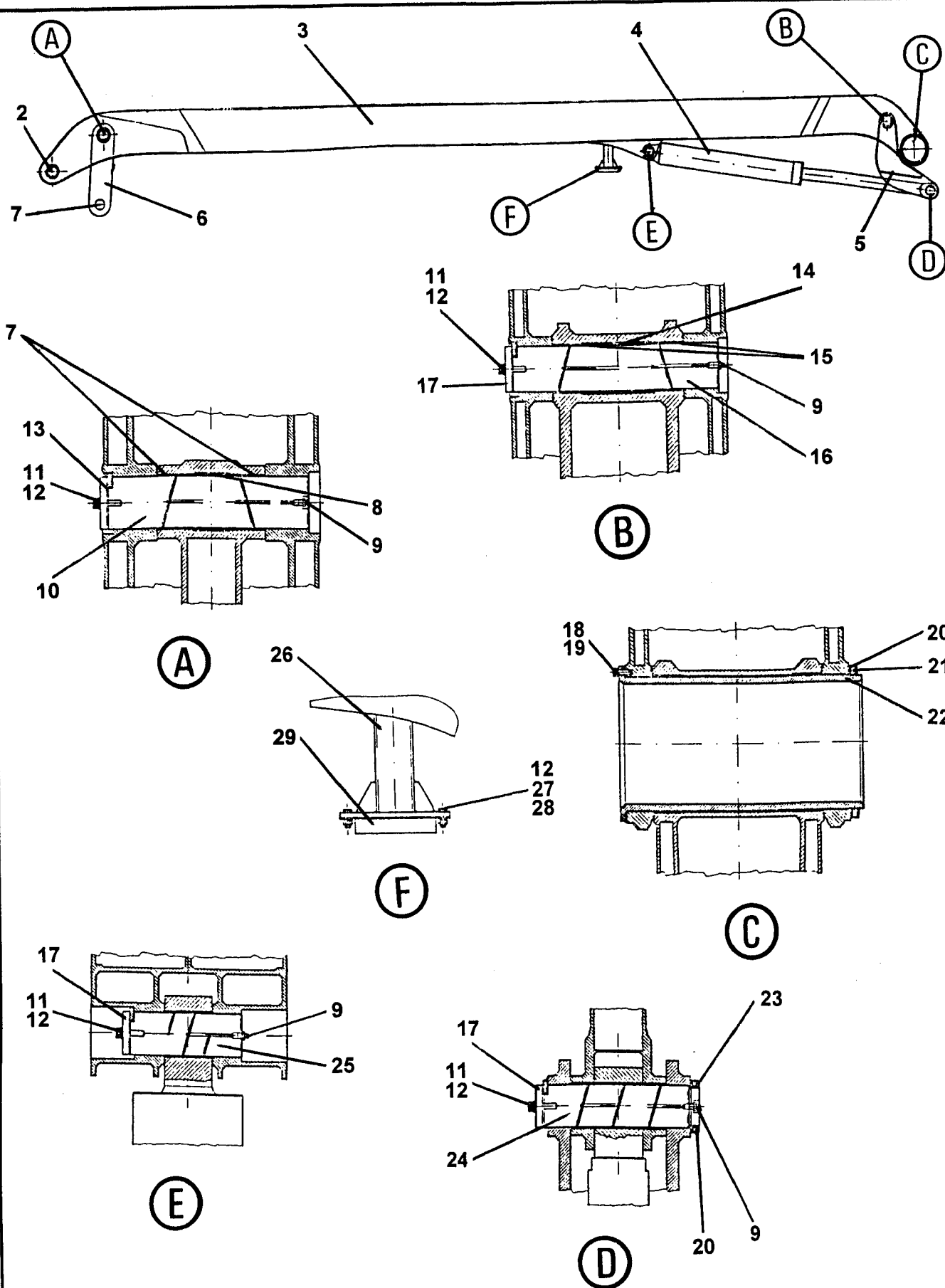

ITEM NO.	REED'S PARTS NO.	DESCRIPTION					QTY
		1	2	3	4	5	
-1	B-661050	Assembly, Boom Section "B" (See Group 90, Figure 01 for NHA)					Ref
2	W-106018	• Bushing					2
3	B-671200	• Weldment, Boom Section "B"					1
4	W-106191	• Assembly, Boom Cylinder "3" (See Group 90, Figure 06 for DET)					1
5	B-671620	• Coupling, Boom "C" Beam					1
6	B-671710	• Coupling, Forcing Rod for Boom "B"					1
7	W-106017	• Bushing					4
8	B-660070	• Spacer, Pin					1
9	W-100805	• Nipple, Grease					4
10	B-660063	• Pin, Pivot					1
11	W-102070	• Washer, Pin					6
12	W-106654	• Screw, Cylinder Head					4
13	B-660058	• Washer					1
14	B-660071	• Spacer, Pin					1
15	W-106655	• Bushing					2
16	B-660064	• Pin, Pivot					1
17	B-660065	• Washer					1
18	W-103273	• Screw					4
19	W-102205	• Washer, Spring					4
20	W-103646	• Screw, Set					4
21	B-660066	• Ring, Thread Pin					1
22	B-660065	• Washer					1
23	B-660068	• Ring, Thread Pin					1
24	B-660067	• Pin, Pivot					2
25	B-660069	• Pin, Pivot					1
26	B-661085	• Holder					1
27	W-101553	• Bolt, Hex					2
28	W-102125	• Nut, Hex					2
29	W-106653	• Cushion, Rubber					1

DASH (-) ITEM NOT ILLUSTRATED



BOOM CYLINDER "3" ASSEMBLY

XT 36
PARTS
GROUP 90
FIGURE 06
PAGE 01

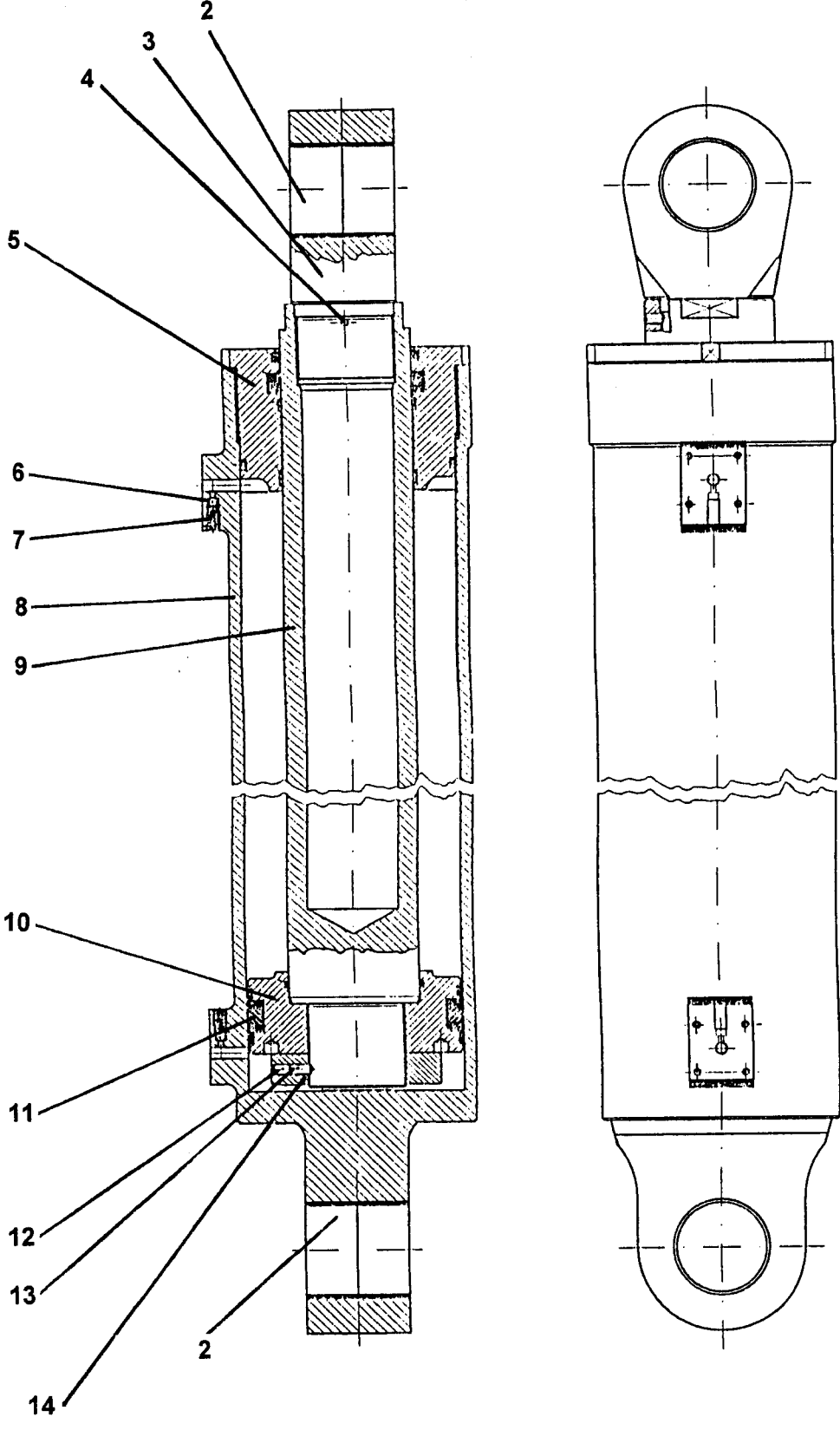

ITEM NO.	REED'S PARTS NO.	DESCRIPTION					QTY
		1	2	3	4	5	
-1	W-106191	Assembly, Boom Cylinder "3" (See Group 90, Figure 05 for NHA)					Ref
2	W-106014	• Bushing					4
3	W-106737	• Head, Piston					1
4	W-106740	• Screw, Set					1
5	W-106736	• Guide, Piston					1
6	W-106723	• Ball, Still					2
7	W-106722	• Valve, Air Hole					2
8	W-106732	• Cylinder					1
9	W-106735	• Rod, Piston					1
10	W-106733	• Piston					1
11	W-104035	• Kit, Seal					1
12	W-106739	• Screw, Set					1
13	W-106738	• Screw, Set					1
14	W-106734	• Nut, Piston					1

DASH (-) ITEM NOT ILLUSTRATED

REED

BOOM SECTION "C" ASSEMBLY

XT 36
PARTS
GROUP 90
FIGURE 07
PAGE 01

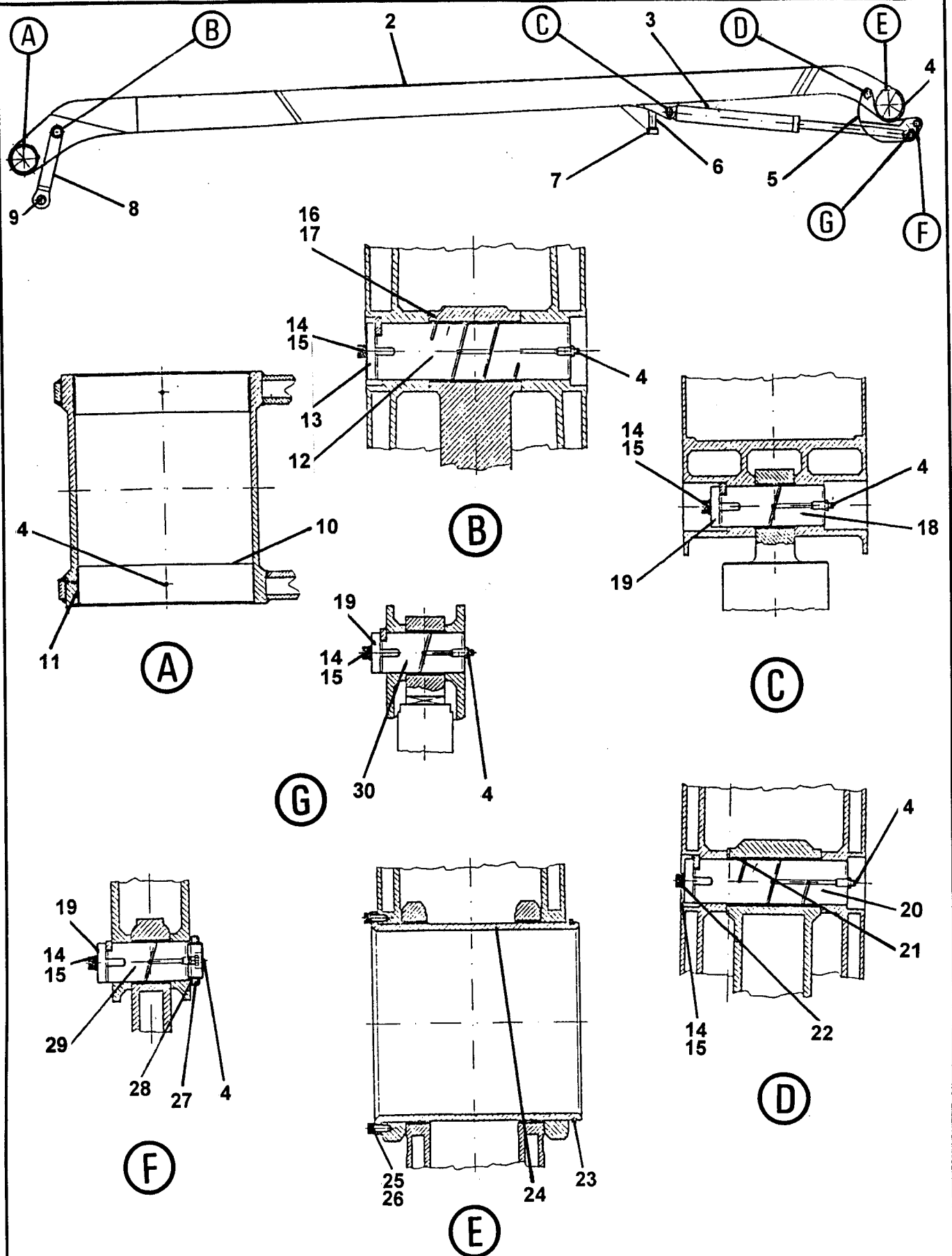

REVISION:

ITEM NO.	REED'S PARTS NO.	DESCRIPTION					QTY
		1	2	3	4	5	
-1	B-661060	Assembly, Boom Section "C" (See Group 90, Figure 01 for NHA)					Ref
2	B-671200	• Weldment, Boom Section "C"					1
3	W-106192	• Assembly, Boom Cylinder "4" (See Group 90, Figure 08 for DET)					1
4	W-100805	• Nipple, Grease					9
5	B-671720	• Coupling, Forcing Rod for Boom "D"					1
6	B-661090	• Holder					1
7	W-106660	• Cushion, Rubber					1
8	B-671630	• Coupling, Boom "C" Beam					1
9	W-106014	• Bushing					2
10	W-106023	• Bushing					2
11	W-106662	• Ring, Wear					2
12	B-660078	• Pin, Pivot					1
13	B-660065	• Washer, Pin					1
14	W-106654	• Screw, Cylinder Head					5
15	W-102070	• Washer, Pin					5
16	W-106659	• Bushing					1
17	W-106615	• Bushing					1
18	W-106090	• Pin, Pivot					1
19	B-660076	• Washer					3
20	B-660079	• Pin, Pivot					1
21	W-106013	• Bushing					2
22	B-660077	• Washer					1
23	W-106661	• Ring, Clamping					1
24	B-660075	• Pin, Pivot					1
25	W-103273	• Screw					4
26	W-102205	• Washer, Spring					4
27	W-103646	• Screw, Set					2
28	B-660073	• Ring, Thread Pin					1
29	B-660072	• Pin, Pivot					1
30	B-660074	• Pin, Pivot					1

DASH (-) ITEM NOT ILLUSTRATED

REED

BOOM CYLINDER "4" ASSEMBLY

XT 36
PARTS
GROUP 90
FIGURE 08
PAGE 01

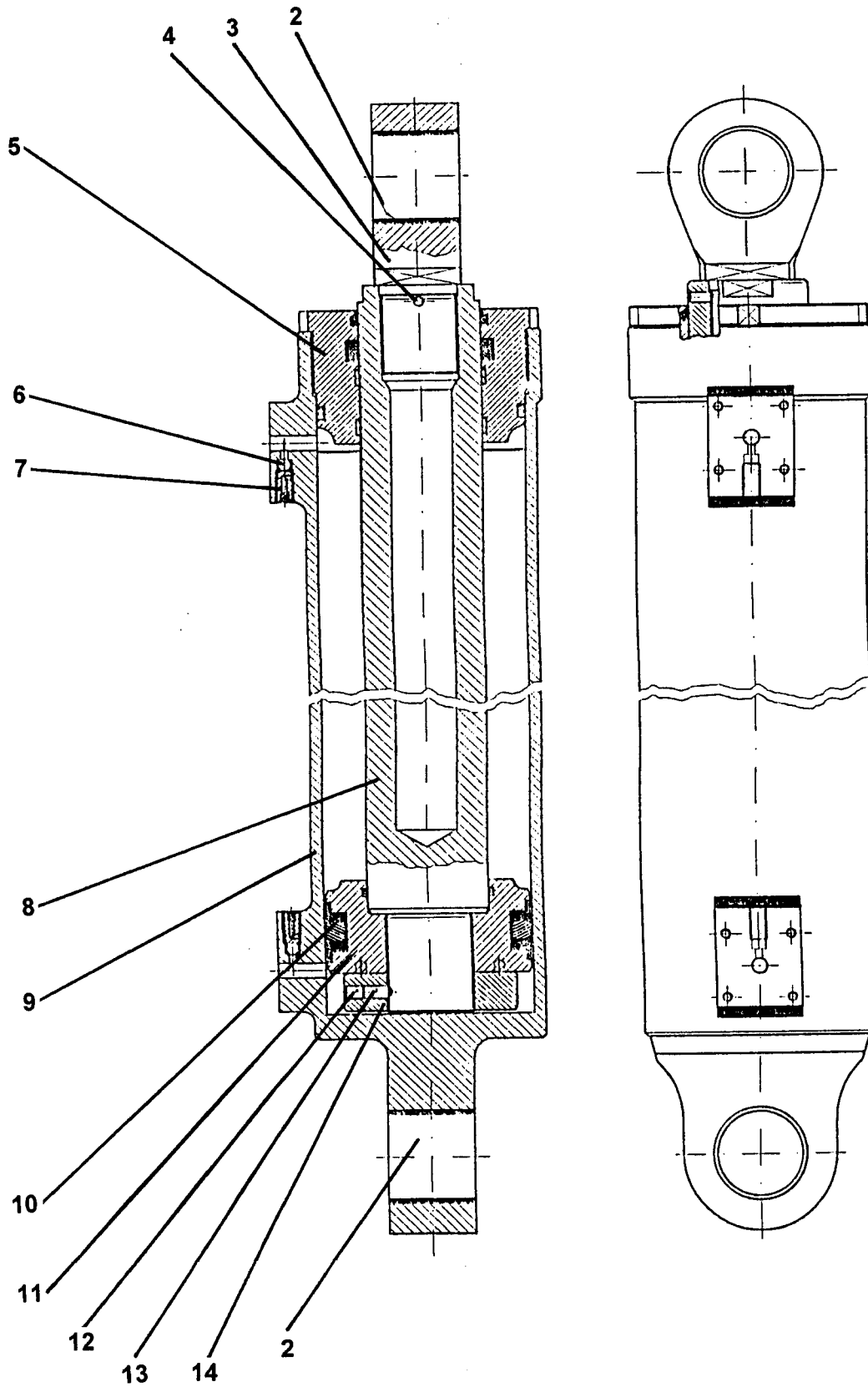

ITEM NO.	REED'S PARTS NO.	DESCRIPTION					QTY
		1	2	3	4	5	
-1	W-106192	Assembly, Boom Cylinder "4" (See Group 90, Figure 07 for NHA)					Ref
2	W-106012	• Bushing					2
3	W-106746	• Head, Piston					1
4	W-106747	• Screw, Set					1
5	W-106745	• Guide, Piston					1
6	W-106723	• Ball, Still					2
7	W-106722	• Valve, Air Hole					2
8	W-106744	• Rod, Piston					1
9	W-106741	• Cylinder					1
10	W-104036	• Kit, Seal					1
11	W-106742	• Piston					1
12	W-106739	• Screw, Set					1
13	W-106738	• Screw, Set					1
14	W-106743	• Nut, Piston					1

DASH (-) ITEM NOT ILLUSTRATED

REED

BOOM SECTION "D" ASSEMBLY

XT 36
PARTS
GROUP 90
FIGURE 09
PAGE 01

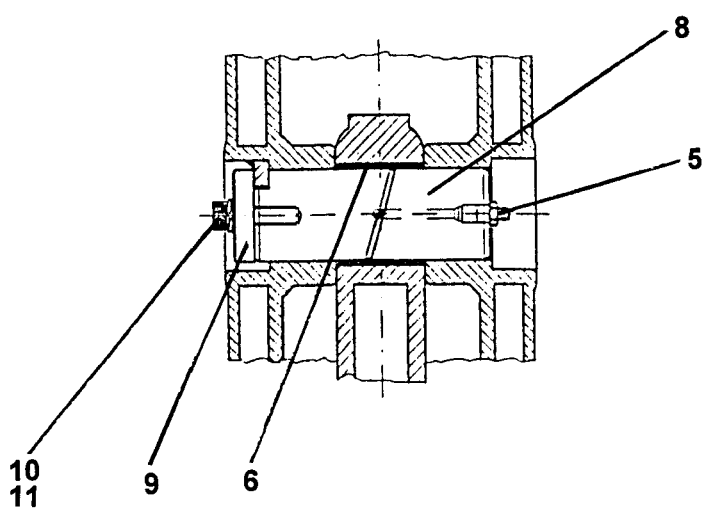
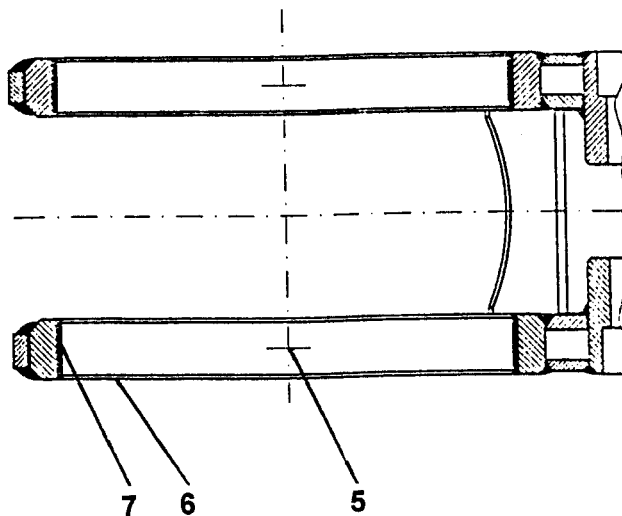
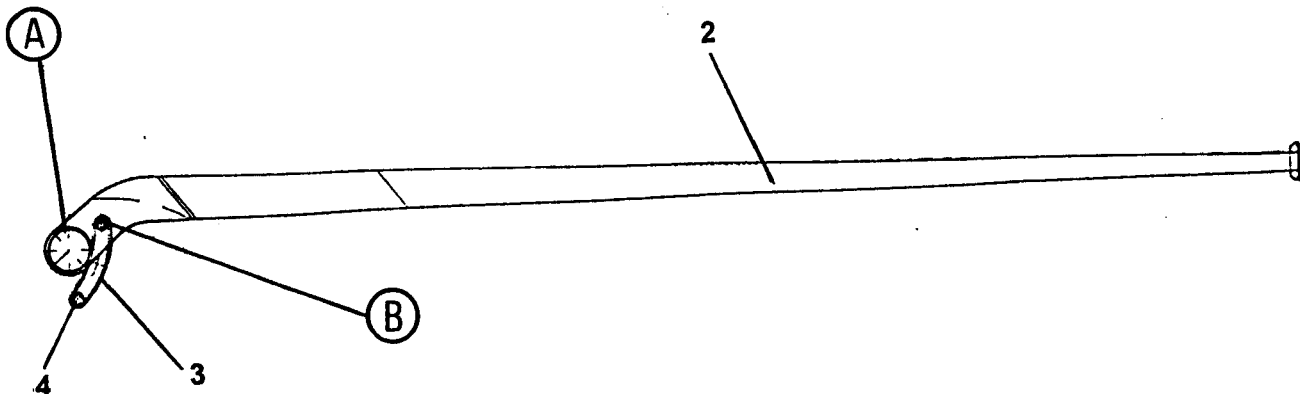

(B)

(A)

ITEM NO.	REED'S PARTS NO.	DESCRIPTION					QTY
		1	2	3	4	5	
-1	B-661070	Assembly, Boom Section "D" (See Group 90, Figure 01 for NHA)					Ref
2	B-671400	• Weldment, Boom Section "D"					1
3	B-671730	• Coupling, Forcing Rod for Boom "D"					1
4	W-106012	• Bushing					2
5	W-100805	• Nipple, Grease					3
6	W-106663	• Ring, Wear					2
7	W-106022	• Bushing					2
8	W-106090	• Pin, Pivot					1
9	B-660076	• Washer, Pin					1
10	W-106654	• Screw					1
11	W-102070	• Washer, Spring					1

DASH (-) ITEM NOT ILLUSTRATED

REED

BOOM DELIVERY LINE
XT36 SN # 227

XT36

GROUP 90

802430

7/14/01

Fig 10 Page 1

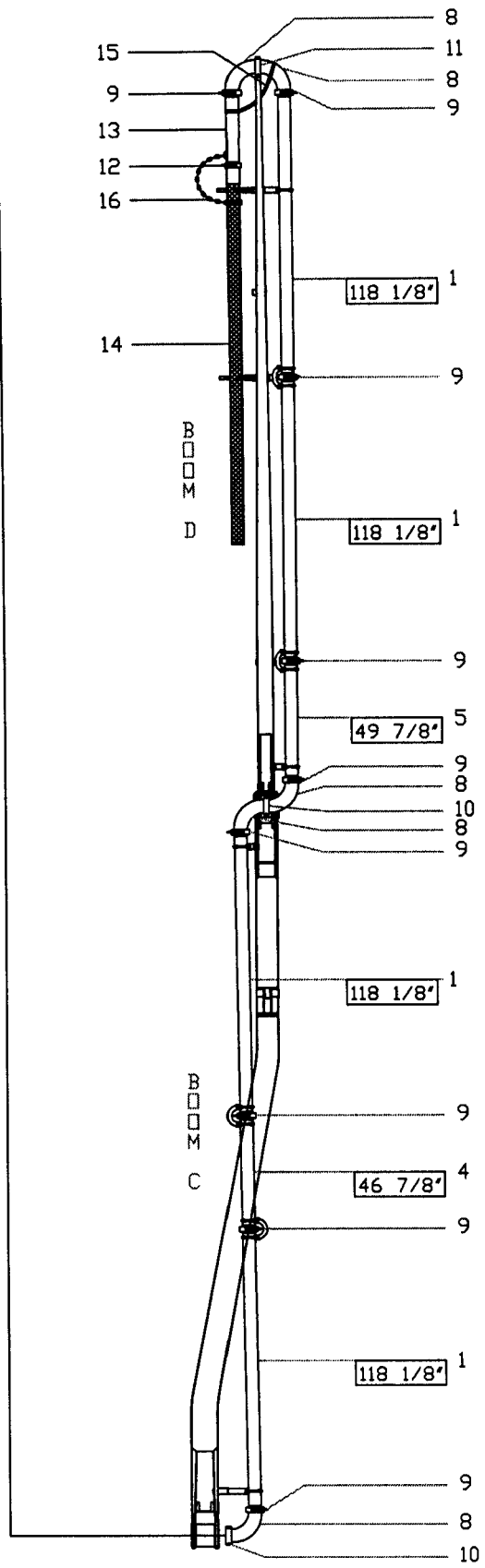
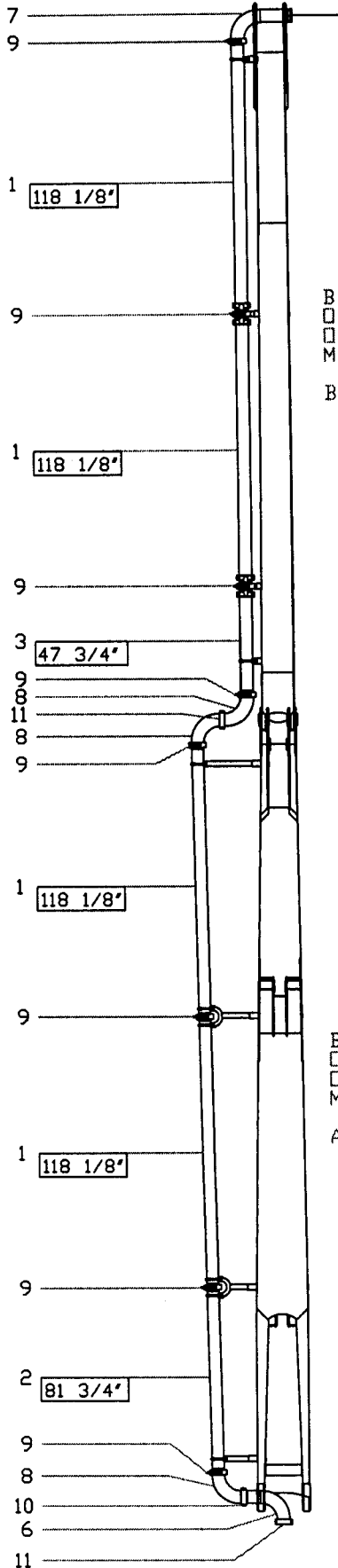

REED

BOOM DELIVERY LINE
XT36 SN # 227

XT36

GROUP 90

802430

7/14/01

Fig 10 Page 2

Code	Description	Part No.	Qty	
	BOOM DELIVERY LINE			
1	Boom Pipe, 3000mm	801105-3000	8	
2	Boom Makeup Pipe, A Boom	801105-2076	1	
3	Boom Makeup Pipe, B Boom	801105-1213	1	
4	Boom Makeup Pipe, C Boom	801105-1190	1	
5	Boom Makeup Pipe, D Boom	801105-1267	1	
6	Boom Elbow	801102	1	
7	Boom Elbow	801104	1	
8	Boom Elbow	800327	8	
9	Snap Coupling, 148mm	800070	16	
10	Two Bolt Coupling, 148mm	802091	3	
11	Two Bolt Coupling, 148mm w/ Base	802092	3	
	END HOSE - 4 IN			
9	Snap Coupling, 148mm	800070	1	
12	Snap Coupling, 4" HD	71530	1	
13	Reducer, 148mm x 4" HD	800067	1	
14	End Hose, 4 IN x 10 FT	800068	1	
15	Web Sling	801770	1	
16	Chain	801671	1 FT	

REED

DECK DELIVERY LINE
XT36 SN # 227

XT36

GROUP 90

802293

A

7/17/01

Fig 11 Page

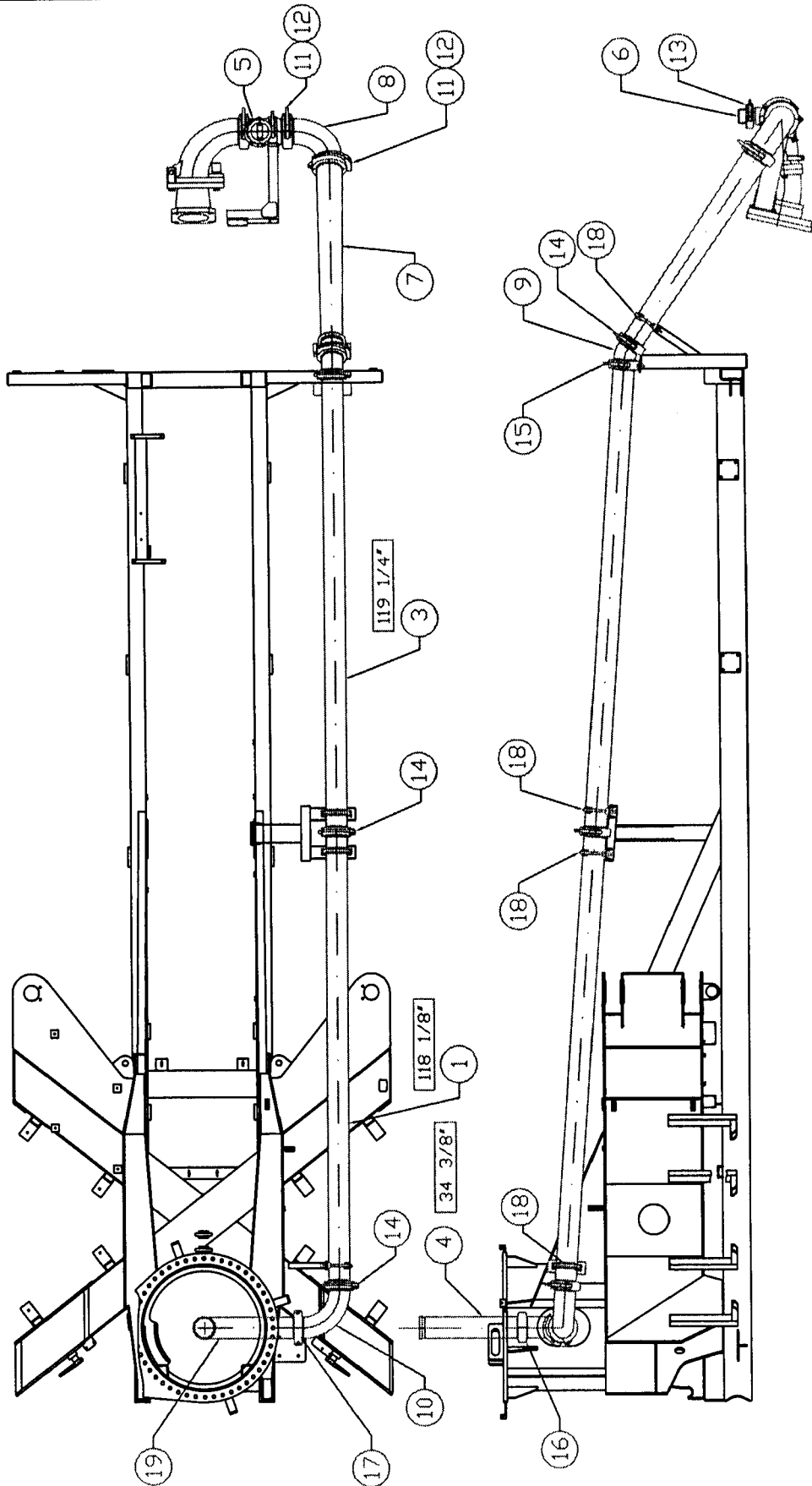

REED

DECK DELIVERY LINE

XT36

XT36 SN # 227

GROUP 90

802293

A

7/17/01

Fig 11 Page 2

Code	Description	Part No.	Qty
DECK DELIVERY LINE			
1	Deck Pipe, 3000mm	801967-3000	1
2	Deck Pipe, 305mm	801967-305	1
3	Deck Makeup Pipe, Deck	801967-3067	1
4	Deck Makeup Pipe, Pedestal	801967-883	1
5	Adaptor, Hopper Elbow	801558	1
6	Cap Weldment	801565	1
7	Reducer, 6" HP x 148mm	800326	1
8	Elbow, 6" HP Male/Female	800336	1
9	Elbow, 148mm x 30 Deg	800328	1
10	Elbow, 148mm	800327	1
11	Snap Coupling, 6" HP	72242	1
12	Gasket, 6" HP	72241	2
13	Snap Coupling, 4" HD	71530	1
14	Snap Coupling, 148mm	800070	3
15	Snap Coupling, 148mm w/ Base	802296	1
16	Two Bolt Coupling, 148mm	802291	1
17	Two Bolt Coupling, 148mm w/Base	802292	1
18	U-Clamp, 140mm	800341	4
19	Elbow, REMOVE EARS	802426	1

REED

**MODEL XT 36 TRUCK MOUNTED
CONCRETE BOOM PUMP
ILLUSTRATED PARTS MANUAL**

**XT 36
PARTS
GROUP 90
FIGURE 12
PAGE 01**

THIS PAGE INTENTIONALLY LEFT BLANK.