

REED TRAILER MOUNTED CONCRETE PUMP 01 MODEL B70 ILLUSTRATED PARTS MANUAL CONTAINS THE FOLLOWING GROUPS AND FIGURES:

GROUP 00 HOW TO USE PARTS MANUAL

- FIGURE 00 TABLE OF CONTENTS**
- FIGURE 01 HOW TO USE PARTS MANUAL**
- FIGURE 02 HOW TO ORDER PARTS**

GROUP 10 FINAL INSTALLATION

- FIGURE 00 TABLE OF CONTENTS**
- FIGURE 01 HARSH MIX HOPPER WITH DUAL SHIFT INSTALLATION**
- FIGURE 02 DECAL ASSEMBLY**

GROUP 20 HOPPER INSTALLATION

- FIGURE 00 TABLE OF CONTENTS**
- FIGURE 01 HARSH MIX HOPPER INSTALLATION**
- FIGURE 02 HOPPER CLEAN OUT DOOR ASSEMBLY**
- FIGURE 03 HARSH MIX HOPPER AGITATOR ASSEMBLY**
- FIGURE 04 HARSH MIX HOPPER AGITATOR MOTOR ASSEMBLY**
- FIGURE 05 3 SPOOL CONTROL VALVE ASSEMBLY**
- FIGURE 06 3 SPOOL CONTROL VALVE SUB-ASSEMBLY**

GROUP 30 TANK INSTALLATION

FIGURE 00	TABLE OF CONTENTS
FIGURE 01	TANK INSTALLATION
FIGURE 02	HYDRAULIC TANK ASSEMBLY
FIGURE 03	SWING TUBE CIRCUIT MANIFOLD ASSEMBLY
FIGURE 04	SWING TUBE CIRCUIT MAIN SOLENOID VALVE ASSEMBLY
FIGURE 05	SWING TUBE CIRCUIT PILOT SOLENOID VALVE ASSEMBLY
FIGURE 06	BALL VALVE ASSEMBLY
FIGURE 07	DRIVE CYLINDER CIRCUIT MANIFOLD ASSEMBLY
FIGURE 08	DRIVE CYLINDER CIRCUIT MAIN SOLENOID VALVE ASSEMBLY
FIGURE 09	DRIVE CYLINDER CIRCUIT PILOT SOLENOID VALVE ASSEMBLY
FIGURE 10	ACCUMULATOR ASSEMBLY
FIGURE 11	ACCUMULATOR BLADDER REPAIR KIT

GROUP 40 POWER TRAIN INSTALLATION

FIGURE 00	TABLE OF CONTENTS
FIGURE 01	POWER TRAIN INSTALLATION
FIGURE 02	HYDRAULIC PUMPS ASSEMBLY
FIGURE 03	SINGLE AUXILIARY PUMP ASSEMBLY
FIGURE 04	DOUBLE AUXILIARY PUMP ASSEMBLY
FIGURE 05	MAIN PUMP ASSEMBLY
FIGURE 06	BATTERY MOUNTING ASSEMBLY

GROUP 50 CONTROLS INSTALLATION

FIGURE 00	TABLE OF CONTENTS
FIGURE 01	CONTROLS INSTALLATION
FIGURE 02	CONTROL BOX ASSEMBLY
FIGURE 03	50 FEET CABLE REMOTE CONTROL ASSEMBLY
FIGURE 04	100 FEET CABLE REMOTE CONTROL ASSEMBLY
FIGURE 05	RADIO REMOTE CONTROL ASSEMBLY

GROUP 60 PUMPING TRAIN INSTALLATION

FIGURE 00	TABLE OF CONTENTS
FIGURE 01	DUAL SHIFT PUMPING TRAIN INSTALLATION
FIGURE 02	DUAL SHIFT SWING VALVE ASSEMBLY
FIGURE 03	DUAL SHIFT SWING RAM CYLINDER SUB-ASSEMBLY
FIGURE 04	MATERIAL CYLINDER ASSEMBLY
FIGURE 05	FLUSHBOX ASSEMBLY
FIGURE 06	HYDRAULIC DRIVE CYLINDER ASSEMBLY
FIGURE 07	HYDRAULIC DRIVE CYLINDER SUB-ASSEMBLY

GROUP 70 FRAME INSTALLATION

- FIGURE 00** TABLE OF CONTENTS
- FIGURE 01** FRAME INSTALLATION
- FIGURE 02** HUB AND BRAKE ASSEMBLY
- FIGURE 03** NON-OPERATOR SIDE ELECTRIC BRAKE ASSEMBLY
- FIGURE 04** OPERATOR SIDE ELECTRIC BRAKE ASSEMBLY

GROUP 80 OPTIONAL INSTALLATION

- FIGURE 00** TABLE OF CONTENTS
- FIGURE 01** OPTIONAL INSTALLATION
- FIGURE 02** LUBE SYSTEM ASSEMBLY
- FIGURE 03** 12 VOLT LUBE PUMP ASSEMBLY
- FIGURE 04** HOPPER VIBRATOR ASSEMBLY
- FIGURE 05** THROTTLE SOLENOID ASSEMBLY
- FIGURE 06** ACCUMULATOR CHARGE KIT
- FIGURE 07** OPTIONAL TOOL KIT ASSEMBLY
- FIGURE 08** ACTUATOR BRAKES ASSEMBLY
- FIGURE 09** WATER PUMP INSTALLATION
- FIGURE 10** WATER PUMP CONTROL VALVE ASSEMBLY
- FIGURE 11** WATER PUMP MOTOR ASSEMBLY
- FIGURE 12** WATER PUMP ASSEMBLY
- FIGURE 13** NON-OPERATOR SIDE HYDRAULIC BRAKE ASSEMBLY
- FIGURE 14** OPERATOR SIDE HYDRAULIC BRAKE ASSEMBLY
- FIGURE 15** HYDRAULIC OUTRIGGER CYLINDER ASSEMBLY
- FIGURE 16** 1 SPOOL CONTROL VALVE ASSEMBLY
- FIGURE 17** 1 SPOOL CONTROL VALVE SUB-ASSEMBLY
- FIGURE 18** 2 SPOOL CONTROL VALVE ASSEMBLY
- FIGURE 19** 2 SPOOL CONTROL VALVE SUB-ASSEMBLY
- FIGURE 20** SIDE DOOR ASSEMBLY
- FIGURE 21** 50 FEET STROKE COUNTER REMOTE CONTROLLER
- FIGURE 22** 100 FEET STROKE COUNTER REMOTE CONTROLLER

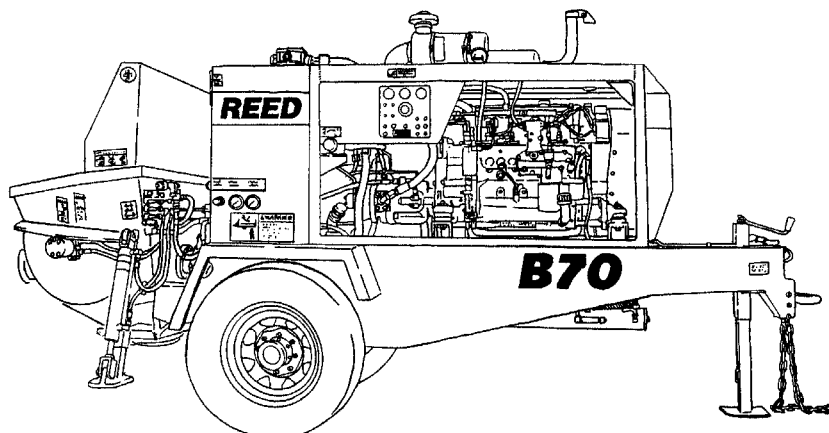



TRAILER MOUNTED PUMP 01 MODEL B70 HOW TO USE PART MANUAL

01 B70
PARTS
GROUP 00
FIGURE 01
PAGE 01

I. PURPOSE

This parts manual is prepared, issued and/or revised by **REED** Manufacturing, for the exclusive use of its customers and is intended for use in provisioning, requisitioning, storing and issuing replaceable **REED** trailer mounted pump **01** model **B70**. The contents are proprietary to **REED** and are subject to change without notice. The use of any part of this document by any other person or persons or for any other purpose without the written consent of **REED** is expressly prohibited. In addition, **REED** expressly disclaims any and all responsibility arising in or any way related to such **REED's** prior written consent thereto.

The parts number content of this document, arrangement and breakdown sequence of items is compatible with Military Standard (**MS**) and Air Transport Association Specification (**ATA**).

II. GENERAL SYSTEM OF ASSEMBLY ORDER – Detailed Parts List (Refer to Next Page)

1. This area refers to the corresponding illustration

MODEL – GROUP – FIGURE – PAGE

A. **MODEL** shows which is **REED's** model number.

B. **GROUP** should be divided with:

00	01 MODEL B70 PARTS MANUAL
10	FINAL INSTALLATION
20	HOPPER INSTALLATION
30	TANK INSTALLATION
40	POWER TRAIN INSTALLATION
50	CONTROL INSTALLATION
60	PUMPING TRAIN INSTALLATION
70	FRAME INSTALLATION
80	OPTIONAL INSTALLATION

C. **FIGURE** belong to the group. Please see page of contents and each group.

D. **PAGE** numbers follow to the right of each figure number.

2. The **ITEM NUMBER** corresponds to the item number shown for the part in illustration. Parts with item number preceded by a dash (such as: -1, -5, -12 etc.) are not illustrated.

3. **PARTS NUMBERS** that carry a **REED** part number.



TRAILER MOUNTED PUMP 01 MODEL B70 HOW TO USE PART MANUAL

01 B70
PARTS
GROUP 00
FIGURE 01
PAGE 02

DUAL SHIFT SWING VALVE ASSEMBLY

01 B40
PARTS
GROUP 60
FIGURE 04
PAGE 02

ITEM NO.	REED'S PARTS NO.	DESCRIPTION					QTY
		1	2	3	4	5	
-1	60-04	Assembly, Dual Shift Swing Valve (See Group 60, Figure 02 for NHA)					Ref
-2	86321	• Assembly, Outlet Group					1
3		•• Nut					6
4	72482	•• Outlet, Machine 5"					1
5		•• Fitting, Grease					2
6	79895	•• Kit, Outlet Seal					1
7	77761	••• O-Ring, Large					1
8	77762	••• O-Ring, Small					1
9	86504	•• Seal, Modified Outlet Thick					1
10	77763	••• Band, Guide					1
11	77765	••• Seal, Outlet Thick					1
12	72309	•• Housing, Outlet Seal					1
13		•• Bolt, Hex					6
14		•• Nut, Nylock (attaching parts)					8
15		•• Washer, Lock (attaching parts)					6
16	70042	•• Outlet, Chromed					1
17		•• Bolt, Hex (attaching parts)					6
-18	86317	• Assembly, Swing Tube Group					1
19	85965	•• Weldment, Harsh Swing Tube					1
20	86065	•• Seal, 6 Inch Single Lip					1
21	72310	•• Ring, 6 Inch Single Lip Wear					1
22	86031	•• Plate, Wear					1
23	86086	•• Ring, Anti Chip					2
24		•• Bolt, Flat Head					4
25		•• Washer, Lock					4
26		•• Nut, Hex					4
27		•• Bolt, Hex					6
28		•• Washer, Lock					6
29	85962	•• Seal, Flange Bearing					1
30		•• Pin, Dowel					1
31		•• Fitting, Grease 90					2
32	85133	•• Bearing, 3 Inch Spline Flange					1
33	85294	•• Washer, Thrust					1
34	85134	•• Spacer, Swing Tube Nut					1
35	70825	•• Nut, Swing Tube					1
36		•• Pin Cotter					1
-37	86320	• Assembly, Swing Tube Dual Shift Group					1
38		•• Plug, Pipe					4
39	86052	•• Pin, Spring					4
40		•• Fitting, Grease 90					2
41	86441	•• Retainer, Swing Ram					2

DASH (-) ITEM NOT ILLUSTRATED

REVISION:

REVISION:

2

3

4

5

1



DUAL SHIFT SWING VALVE ASSEMBLY

01 B40
PARTS
GROUP 60
FIGURE 04
PAGE 02

ITEM NO.	REED'S PARTS NO.	DESCRIPTION					QTY
		1	2	3	4	5	
-1	60-04	Assembly, Dual Shift Swing Valve (See Group 60, Figure 02 for NHA)					Ref
-2	86321	• Assembly, Outlet Group					1
3		• Nut					6
4	72482	• Outlet, Machine 5"					1
5		• Fitting, Grease					2
6	79895	• Kit, Outlet Seal					1
7	77761	•• O-Ring, Large					1
8	77762	••• O-Ring, Small					1
9	86504	••• Seal, Modified Outlet Thick					1
10	77763	••• Band, Guide					1
11	77765	••• Seal, Outlet Thick					1
12	72309	• Housing, Outlet Seal					1
13		• Bolt, Hex					6
14		• Nut, Nylock (attaching parts)					6
15		• Washer, Lock (attaching parts)					6
16	70042	• Outlet, Chromed					1
17		• Bolt, Hex (attaching parts)					6
-18	86317	• Assembly, Swing Tube Group					1
19	85965	• Weldment, Harsh Swing Tube					1
20	86065	• Seal, 6 Inch Single Lip					1
21	72310	• Ring, 6 Inch Single Lip Wear					1
22	86031	• Plate, Wear					1
23	86086	• Ring, Anti Chip					2
24		• Bolt, Flat Head					4
25		• Washer, Lock					4
26		• Nut, Hex					4
27		• Bolt, Hex					6
28		• Washer, Lock					6
29	85962	• Seal, Flange Bearing					1
30		• Pin, Dowel					1
31		• Fitting, Grease 90					2
32	85133	• Bearing, 3 Inch Spline Flange					1
33	85294	• Washer, Thrust					1
34	85134	• Spacer, Swing Tube Nut					1
35	70825	• Nut, Swing Tube					1
36		• Pin Cotter					1
-37	86320	• Assembly, Swing Tube Dual Shift Group					1
38		• Plug, Pipe					4
39	86052	• Pin, Spring					4
40		• Fitting, Grease 90					2
41	86441	• Retainer, Swing Ram					2

DASH (-) ITEM NOT ILLUSTRATED

REVISION:

2

3

4

5

REVISION:



TRAILER MOUNTED PUMP 01 MODEL B70 HOW TO USE PART MANUAL

01 B70
PARTS
GROUP 00
FIGURE 01
PAGE 04

4. DESCRIPTION

A. The **INDENTURE SYSTEM** used in the parts list shows the relationship of one part to another. For a given item, the number of indentures depicts the relationship of the item to the components of the item as follows:

1 2 3 4 5

Assembly (or Installation)

- **Detail part of assembly**
- **Sub-assembly**
- **Attaching parts for sub-assembly**
 - • **Detail part of sub-assembly**
 - • **Sub-sub-assembly**
 - • **Attaching parts for sub-sub-assembly**
 - • • **Detail part of sub-sub-assembly**
 - • • **Sub-sub-sub-assembly**
 - • • **Attaching parts of sub-sub-sub-assembly**
 - • • • **Detail part of sub-sub-sub-assembly**

B. "See Group 60, Figure 02 For **NHA**"

Identifies the illustrated parts chapter location; indicates where the Next Higher Assembly (**NHA**) of the item shown.

C. "See Group 60, Figure 07 For **DET**"

Identifies the illustrated parts chapter location; indicates where the item and its Detailed Breakdown (**DET**) is shown.

D. "See Group 30, Figure 05 for **REF**" or "See Vendor Chapter For **REF**"

Identifies the illustrated parts chapter where the part is, and if listed and illustrated in Vendor Chapter. It is used as a cross-reference (**REF**).

5. QUANTITY

A. Reference (**REF**) indicates the items that is listed previously in the Next Higher Assembly (**NHA**) and then again in this figure.

B. As Required (**A/R**) indicates the parts that is used in a quantity as required.

C. A number entry indicates the quantity of the part used in its next higher application.

6. Functionally related assemblies are illustrated in phantom (— — — —) but not listed on the detail parts list page.



TRAILER MOUNTED PUMP 01 MODEL B70 HOW TO ORDER PARTS

01 B70
PARTS
GROUP 00
FIGURE 02
PAGE 01

1. Always give serial number and model of **REED** trailer mounted concrete pump 01 model **B70**. (Refer to each unit name plate shown below). NOTE: This manual is being released to cover unit starting with serial number **3-01-1-1843** to current production. Some components used on earlier units differ from current productions. Where this occurs, the part is identified by a serial number.

REED		PHONE (909) 287 - 2100	
13822 OAKS AVENUE		FAX (909) 287 - 2140	
CHINO, CA 91710 USA			
MODEL	_____	SERIAL NO	_____
MATERIAL PRESSURE	_____	PSI	_____ 3AR
HYDRAULIC PRESSURE	_____	PSI	_____ 3AR
ENGINE / PTO ELECTRIC MOTOR	_____	RPM	_____ /OLTS
PN 36636			

2. Always specify part number and complete name of parts ordered.
- A. Turn to table of content in the desired Installation. Refer to main group in which part should be listed.
 - B. Find title of figure in which the part should be shown. Note figure number.



TRAILER MOUNTED PUMP 01 MODEL B40
GROUP 60 PUMPING TRAIN INSTALLATION

01 B40
PARTS
GROUP 60
FIGURE 00
PAGE 01

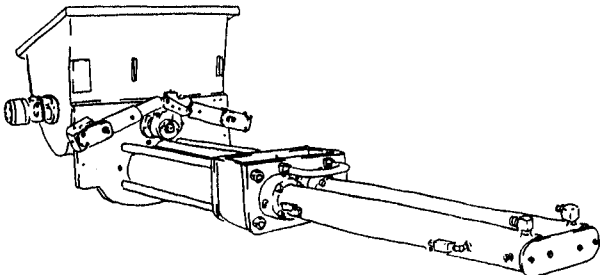

SHOWN MODEL DUAL SHIFT HARSH MIX HOPPER UNIT

REED TRAILER MOUNTED CONCRETE PUMP 01 MODEL B45 ILLUSTRATED PARTS MANUAL GROUP 60 PUMPING TRAIN INSTALLATION CONTAINS THE FOLLOWING FIGURES:

FIGURE 00	TABLE OF CONTENTS
FIGURE 01	SINGLE SHIFT PUMPING TRAIN INSTALLATION
FIGURE 02	DUAL SHIFT PUMPING TRAIN INSTALLATION
FIGURE 03	SINGLE SHIFT SWING VALVE ASSEMBLY
FIGURE 04	DUAL SHIFT SWING VALVE ASSEMBLY
FIGURE 05	SINGLE SHIFT SWING RAM CYLINDER SUB-ASSEMBLY
FIGURE 06	DUAL SHIFT SWING RAM CYLINDER SUB-ASSEMBLY
FIGURE 07	MATERIAL CYLINDER ASSEMBLY
FIGURE 08	FLUSHBOX ASSEMBLY
FIGURE 09	HYDRAULIC DRIVE CYLINDER ASSEMBLY
FIGURE 10	HYDRAULIC DRIVE CYLINDER SUB-ASSEMBLY

REVISION:

REVISION:



TRAILER MOUNTED PUMP 01 MODEL B70 HOW TO ORDER PARTS

01 B70
PARTS
GROUP 00
FIGURE 02
PAGE 02

REED DUAL SHIFT SWING VALVE ASSEMBLY
01 B40 PARTS GROUP 80 FIGURE 04 PAGE 01

HOPPER REF (STANDARD P/N: 86107) (HARSH MIX P/N: 86032)

SWING RAM HOUSE REF (RH P/N: 85941) (LH P/N: 85942)

HOPPER REF (STANDARD P/N: 86107) (HARSH MIX P/N: 86032)

REVISION:

REED DUAL SHIFT SWING VALVE ASSEMBLY
01 B40 PARTS GROUP 80 FIGURE 04 PAGE 02

ITEM NO.	REED'S PARTS NO.	DESCRIPTION	QTY
-1	80-04	Assembly, Dual Shift Swing Valve (See Group 80, Figure 02 for NHA)	Ref
-2	86321	• Assembly, Outlet Group	1
3		• Nut	6
4	72482	• Outlet, Machine 5"	1
5		• Fitting, Grease	2
6	79895	• Kit, Outlet Seal	1
7	77781	••• O-Ring, Large	1
8	77782	••• O-Ring, Small	1
9	86504	•• Seal, Modified Outlet Thick	1
10	77783	•• Band, Guide	1
11	77785	•• Seal, Outlet Thick	1
12	72309	•• Housing, Outlet Seal	1
13		•• Bolt, Hex	6
14		•• Nut, Nylock (attaching parts)	6
15		•• Washer, Lock (attaching parts)	6
16	70042	•• Outlet, Chromed	1
17		•• Bolt, Hex (attaching parts)	6
-18	86317	• Assembly, Swing Tube Group	1
19	85965	•• Weldment, Harsh Swing Tube	1
20	86085	•• Seal, 8 Inch Single Lip	1
21	72310	•• Ring, 8 Inch Single Lip Wear	1
22	86031	•• Plate, Wear	1
23	86086	•• Ring, Anti Chip	2
24		•• Bolt, Flat Head	4
25		•• Washer, Lock	4
26		•• Nut, Hex	4
27		•• Bolt, Hex	6
28		•• Washer, Lock	6
29	85962	•• Seal, Flange Bearing	1
30		•• Pin, Dowel	1
31		•• Fitting, Grease 90	2
32	85733	•• Bearing, 3 Inch Spine Flange	1
33	85294	•• Washer, Thrust	1
34	85769	•• Spacer, Swing Tube Ret	1
35	70825	•• Nut, Swing Tube	1
36		•• Pin Cotter	1
-37	86320	• Assembly, Swing Tube Dual Shift Group	1
38		•• Plug, Pipe	4
39	86082	•• Pin, Spring	4
40		•• Fitting, Grease 90	2
41	86441	•• Retainer, Swing Ram	2

DASH (-) ITEM NOT ILLUSTRATED

REVISION:

C. Turn to corresponding page, find the group and figure.

D. Check your required part and its attaching parts and match with illustration page.

E. Refer to corresponding item number in the part list page. Part numbers are located in the part number column.

F. When ordering variable or optional miscellaneous parts which are not found this in parts chapter, follow the above outlined procedure of how to order parts.

- 1). When applicable, give model and serial number of the component for which parts are desired.
- 2). In a specific, difficult to describe situation, a marked-up photograph or detailed sketch would be helpful.

REVISION:



**TRAILER MOUNTED PUMP 01 MODEL B70
HOW TO ORDER PARTS**

01 B70

PARTS

GROUP 00

FIGURE 02

PAGE 03

3. Do not designate quantity by "set". State specifically how many parts are wanted.
4. Always give complete address and full shipping instructions. Specify shipping instructions, truck freight, air freight. United Parcel Service (UPS), or Air Borne Express and DHL are available in designated areas.

5. TO ORDER

A. BY MAIL

Attention: Parts Department

REED

13822 Oaks Avenue
Chino, CA. 91710 - 7008

B. BY FAX

(909) 287 - 2141

C. BY PHONE

(909) 287 - 2100

6. Parts return without authorization will not be accepted. If it is necessary to return parts for any reason, written authorization may be obtained from **REED** Parts Department, Chino, CA. 91710-7008. A Parts Return Authorization form is provided when **REED** deems its necessary to have the part returned for evaluation. The form is issued by the Warranty of Parts Department of **REED**.
 - A. The form will be filled by **REED** unless requesting necessary information and you will receive a copy as well as shipping tag.
 - B. Attach shipping tag to part insert return original invoice.
 - C. Ship part to **REED PREPAID**.
 - D. Part must be returned to **REED** within 30 days from date of authorization.

REED TRAILER MOUNTED CONCRETE PUMP 01 MODEL B70 ILLUSTRATED PARTS MANUAL GROUP 10 FINAL INSTALLATION CONTAINS THE FOLLOWING FIGURES:

- FIGURE 00** TABLE OF CONTENTS
- FIGURE 01** HARSH MIX HOPPER WITH DUAL SHIFT INSTALLATION
- FIGURE 02** DECAL ASSEMBLY

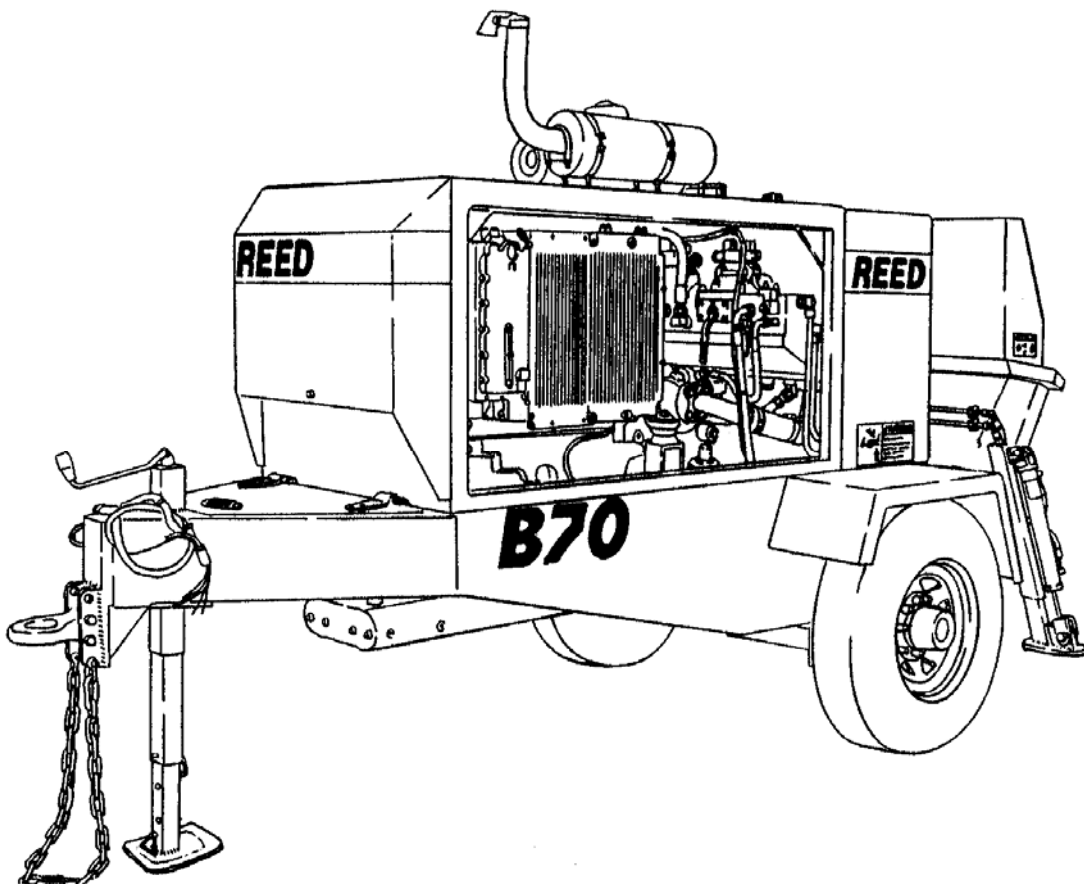



HARSH MIX HOPPER WITH DUAL SHIFT FINAL INSTALLATION

01 B70
PARTS
GROUP 10
FIGURE 01
PAGE 01

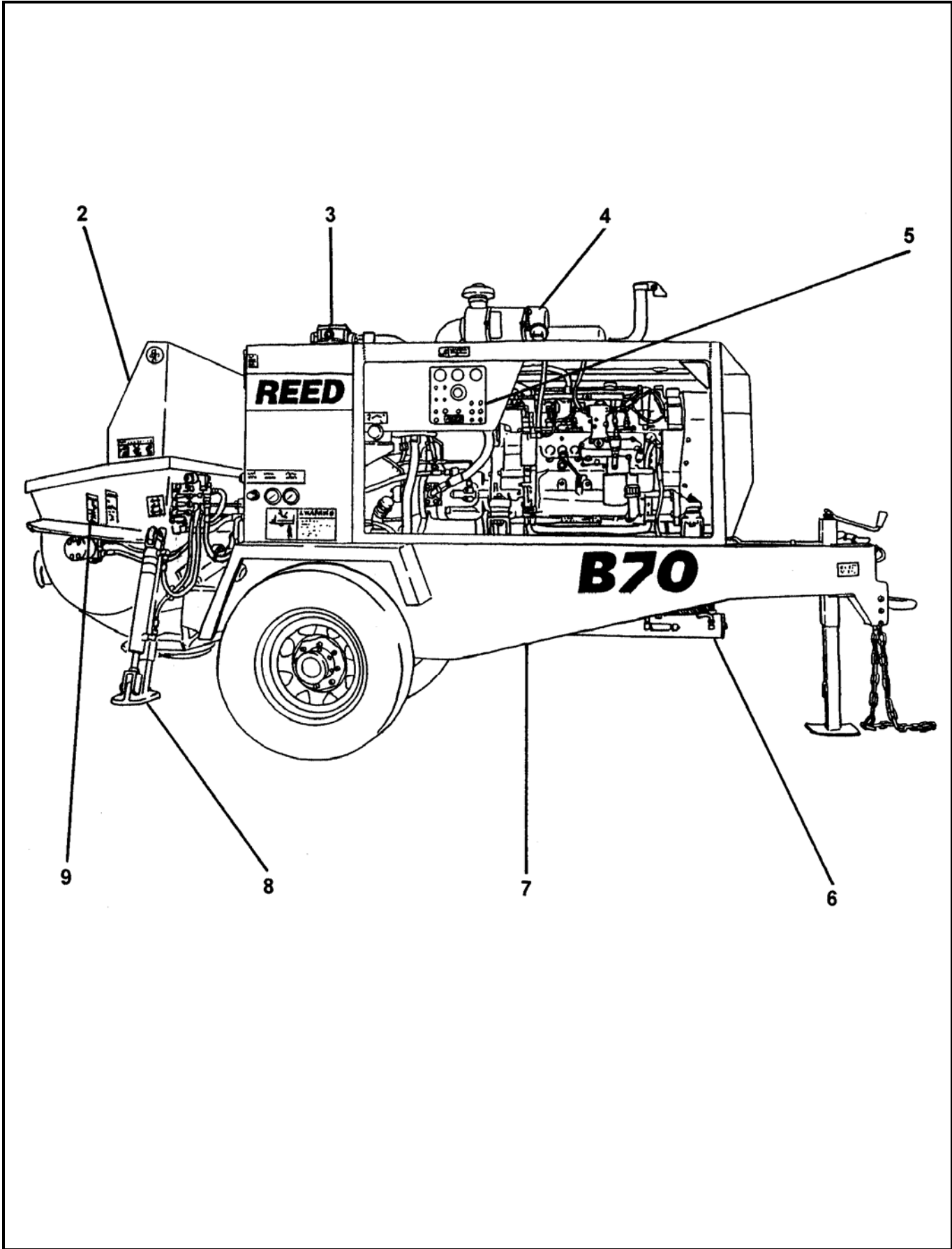

REVISION:



HARSH MIX HOPPER WITH DUAL SHIFT FINAL INSTALLATION

01 B70
PARTS
GROUP 10
FIGURE 01
PAGE 02

ITEM NO.	REED'S PARTS NO.	DESCRIPTION	QTY
		1 2 3 4 5	
-1	B70D-V01	Installation, B70 Harsh Mix Hopper with Dual Shift Final	Ref
2	20-01	• Installation, Harsh Mix Hopper (See Group 20, Figure 02 for DET)	1
3	30-01	• Installation, Tank (See Group 30, Figure 01 for DET)	1
4	40-01	• Installation, Power Train (See Group 40, Figure 01 for DET)	1
5	50-01	• Installation, Control (See Group 50, Figure 01 for DET)	1
6	60-02	• Installation, Dual Shift Pumping Train (See Group 60, Figure 02 for DET)	1
7	70-01	• Installation, Frame (See Group 70, Figure 01 for DET)	1
8	80-01	• Installation, Optional (See Group 80, Figure 01 for DET)	1
9	10-02	• Kit, B70 Decal (See Group 10, Figure 05 for DET)	1

DASH (-) ITEM NOT ILLUSTRATED



DECAL ASSEMBLY

01 B70
PARTS
GROUP 10
FIGURE 02
PAGE 01

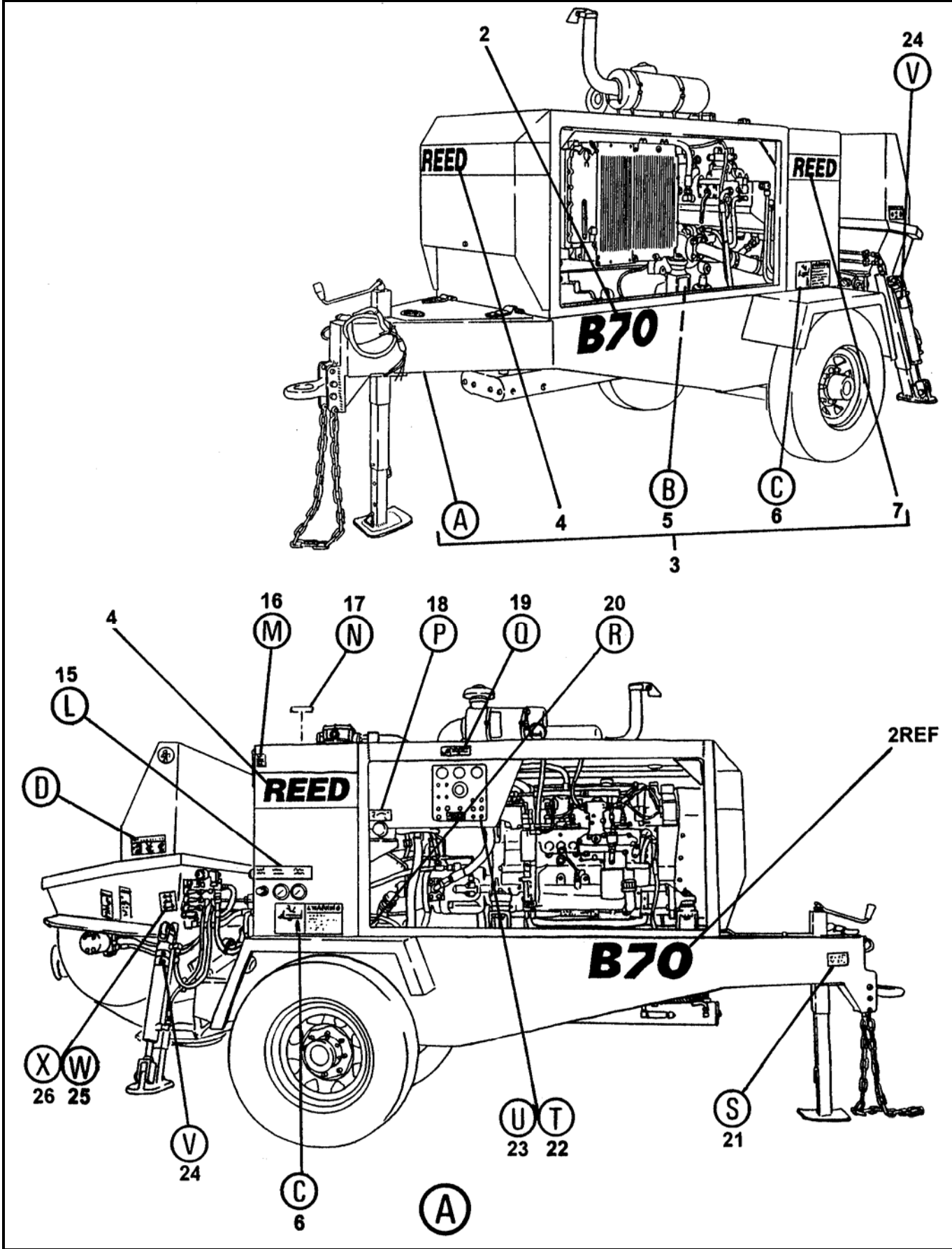

REVISION:



5



ITEM NO.	REED'S PARTS NO.	DESCRIPTION					QTY
		1	2	3	4	5	
-1	10-02	Kit, B70 Decal (See Group 10, Figure 01 for NHA)					Ref
2	86049	• Decal, B70 6 Inch Black					2
3	85425	• Kit, B-Series Decal					1
4	85418	• • Decal, REED 4 1/2 Inch Black and White 48 Inch					2
5	800916	• • Decal, Warning, Keep Hand Out of Water Box					1
6	800924	• • Decal, Warning, This Machine is Remote Controlled and					2
7	85416	• • Decal, REED 4 1/2 Inch Black and White 20 Inch					1
8	800922	• • Decal, Warning, Before Opening a Blocked Pipeline,					1
9	800921	• • Decal, Warning, Do Not Operate at Pressures Exceeding					1
10	73132	• • Decal, REED 4 1/2 Inch					1
11	800931	• • Decal, ACPA Member					1
12	800929A	• • Decal, Warning					2
13	800917	• • Decal, Warning, Keep Hand Out of Hopper and Valve					2
14	800918	• • Decal, Warning, Do Not Stand on Hopper Grate					2
15	85684	• • Decal, B-Series Gauge					1
16	85844	• • Decal, Oil					1
17	75020	• • Decal, Hydraulic Oil					1
18	85413	• • Decal, Volume Control					1
19	800926	• • Decal, Warning, Do Not Operate This Machine without					1
20	75017	• • Decal, Diesel Fuel Only					1
21	86636	• • Nameplate, REED , Serial No.					1
22	85332	• Decal, B70 Control Box Panel					1
23	85410	• Decal, B70 Remote Control					1
24	800919	• Decal, Optional, Warning, Stand Clear Outriggers When					2
25	85845	• Decal, Outriggers (Optional Items)					1
26	85846	• Decal, Agitator (Optional Items)					1

DASH (-) ITEM NOT ILLUSTRATED

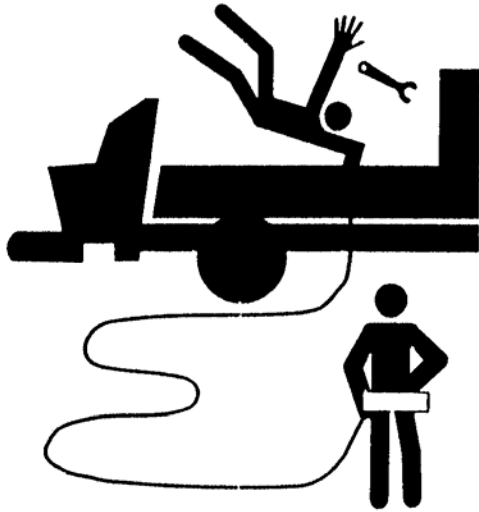

WARNING

This machine is remote controlled and may start at any time. Stop engine before servicing unit.

800924

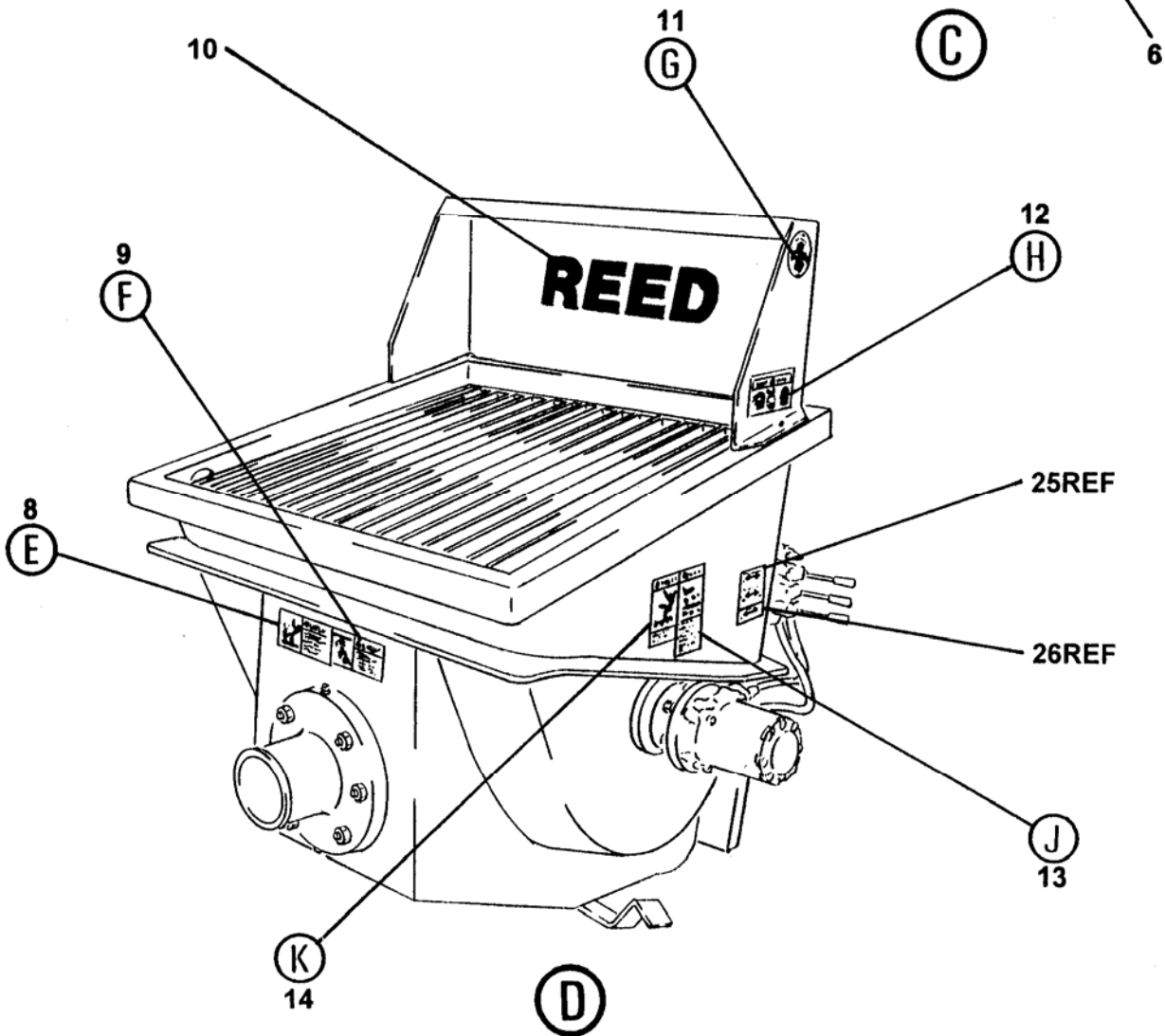



(E)

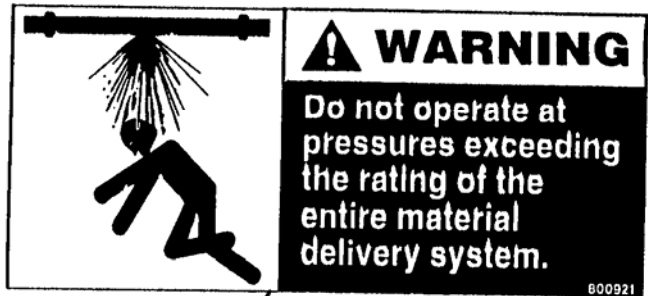

9

(F)



12

(H)



11

(G)

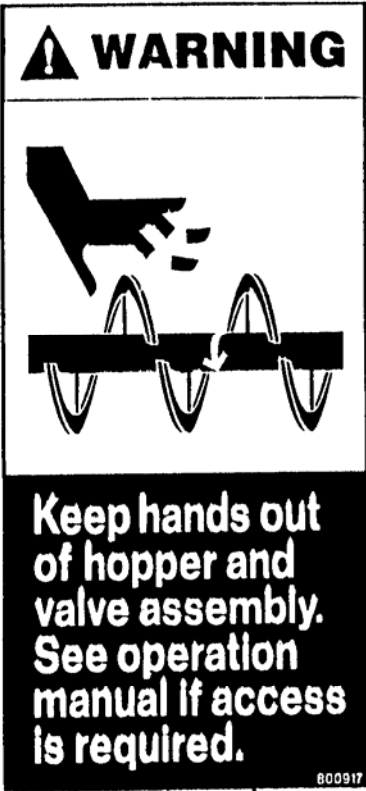

(J)

13



14

(K)

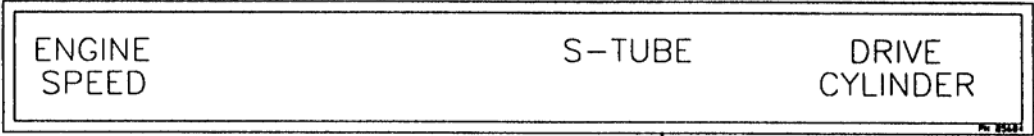

15

(L)

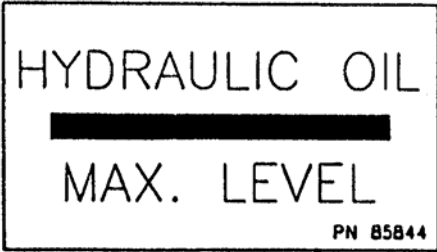

16

(M)

HYDRAULIC OIL

17

(N)

VOLUME CONTROL

PN 85413

(P)

18

**WARNING**
Do not operate this machine without training. Understand the warnings in safety manuals and on decals.
600928

(Q)

19

DIESEL FUEL
ONLY

20

(R)

REED
13822 OAKS AVENUE
CHINO, CA 91710 USA
PHONE (909) 287 - 2100
FAX (909) 287 - 2140

MODEL SERIAL NO.

MATERIAL PRESSURE	<input type="text"/>	PSI	<input type="text"/>	BAR
HYDRAULIC PRESSURE	<input type="text"/>	PSI	<input type="text"/>	BAR
ENGINE / PTO ELECTRIC MOTOR	<input type="text"/>	RPM	<input type="text"/>	VOLTS

PN 86636

(S)

21



DECAL ASSEMBLY

01 B70
PARTS
GROUP 10
FIGURE 02
PAGE 07

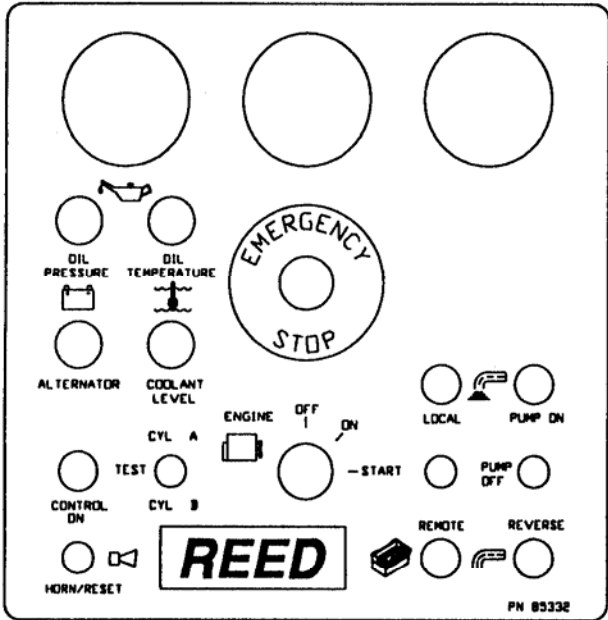

(T)

22

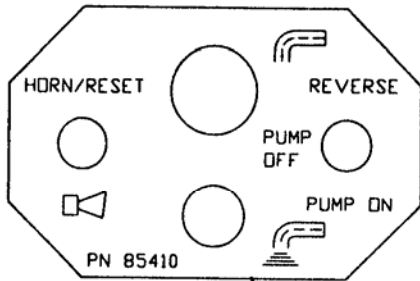

(U)

23

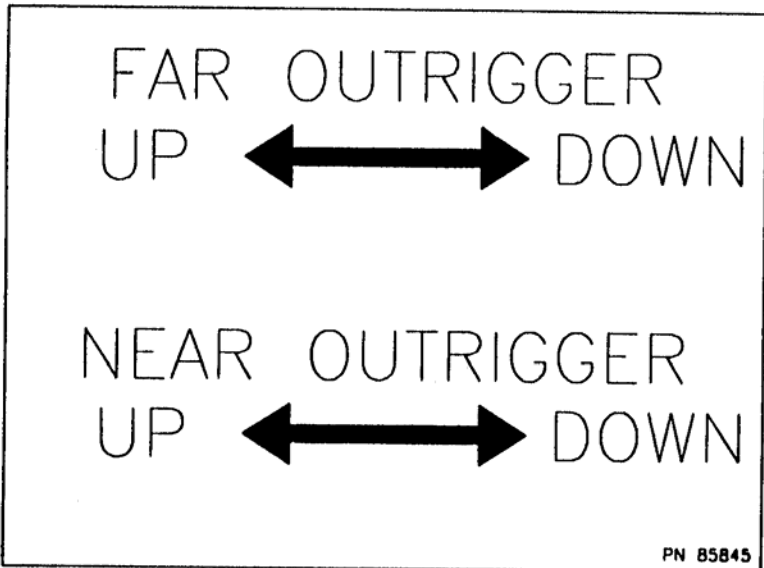

(W)

25

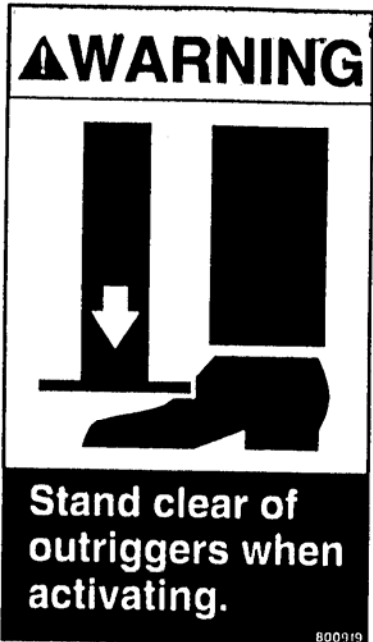

(V)

24



DECAL ASSEMBLY

01 B70
PARTS
 GROUP 10
 FIGURE 02
 PAGE 08

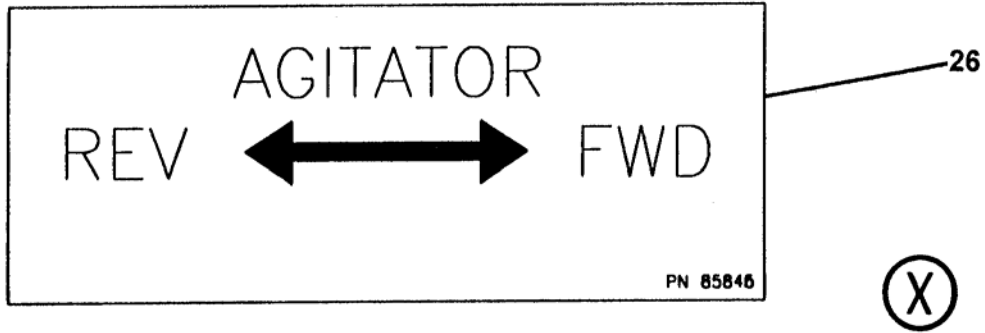

ITEM NO.	REED'S PARTS NO.	DESCRIPTION	QTY
		1 2 3 4 5	
-1	10-02	Kit, B70 Decal (See Group 10, Figure 01 for NHA)	Ref
2	86049	• Decal, B70 6 Inch Black	2
3	85425	• Kit, B-Series Decal	1
4	85418	• • Decal, REED 4 1/2 Inch Black and White 48 Inch	2
5	800916	• • Decal, Warning, Keep Hand Out of Water Box	1
6	800924	• • Decal, Warning, This Machine is Remote Controlled and	2
7	85416	• • Decal, REED 4 1/2 Inch Black and White 20 Inch	1
8	800922	• • Decal, Warning, Before Opening a Blocked Pipeline,	1
9	800921	• • Decal, Warning, Do Not Operate at Pressures Exceeding	1
10	73132	• • Decal, REED 4 1/2 Inch	1
11	800931	• • Decal, ACPA Member	1
12	800929A	• • Decal, Warning	2
13	800917	• • Decal, Warning, Keep Hand Out of Hopper and Valve	2
14	800918	• • Decal, Warning, Do Not Stand on Hopper Grate	2
15	85684	• • Decal, B-Series Gauge	1
16	85844	• • Decal, Oil	1
17	75020	• • Decal, Hydraulic Oil	1
18	85413	• • Decal, Volume Control	1
19	800926	• • Decal, Warning, Do Not Operate This Machine without	1
20	75017	• • Decal, Diesel Fuel Only	1
21	86636	• • Nameplate, REED , Serial No.	1
22	85332	• Decal, B70 Control Box Panel	1
23	85410	• Decal, B70 Remote Control	1
24	800919	• Decal, Optional, Warning, Stand Clear Outriggers When	2
25	85845	• Decal, Outriggers (Optional Items)	1
26	85846	• Decal, Agitator (Optional Items)	1

DASH (-) ITEM NOT ILLUSTRATED

REVISION:

THIS PAGE INTENTIONALLY LEFT BLANK.

REED TRAILER MOUNTED CONCRETE PUMP 01 MODEL B70 ILLUSTRATED PARTS MANUAL GROUP 20 HOPPER INSTALLATION CONTAINS THE FOLLOWING FIGURES:

- FIGURE 00** TABLE OF CONTENTS
- FIGURE 01** HARSH MIX HOPPER INSTALLATION
- FIGURE 02** HOPPER CLEAN OUT DOOR ASSEMBLY
- FIGURE 03** HARSH MIX HOPPER AGITATOR ASSEMBLY
- FIGURE 04** HARSH MIX HOPPER AGITATOR MOTOR ASSEMBLY
- FIGURE 05** 3 SPOOL CONTROL VALVE ASSEMBLY
- FIGURE 06** 3 SPOOL CONTROL VALVE SUB-ASSEMBLY

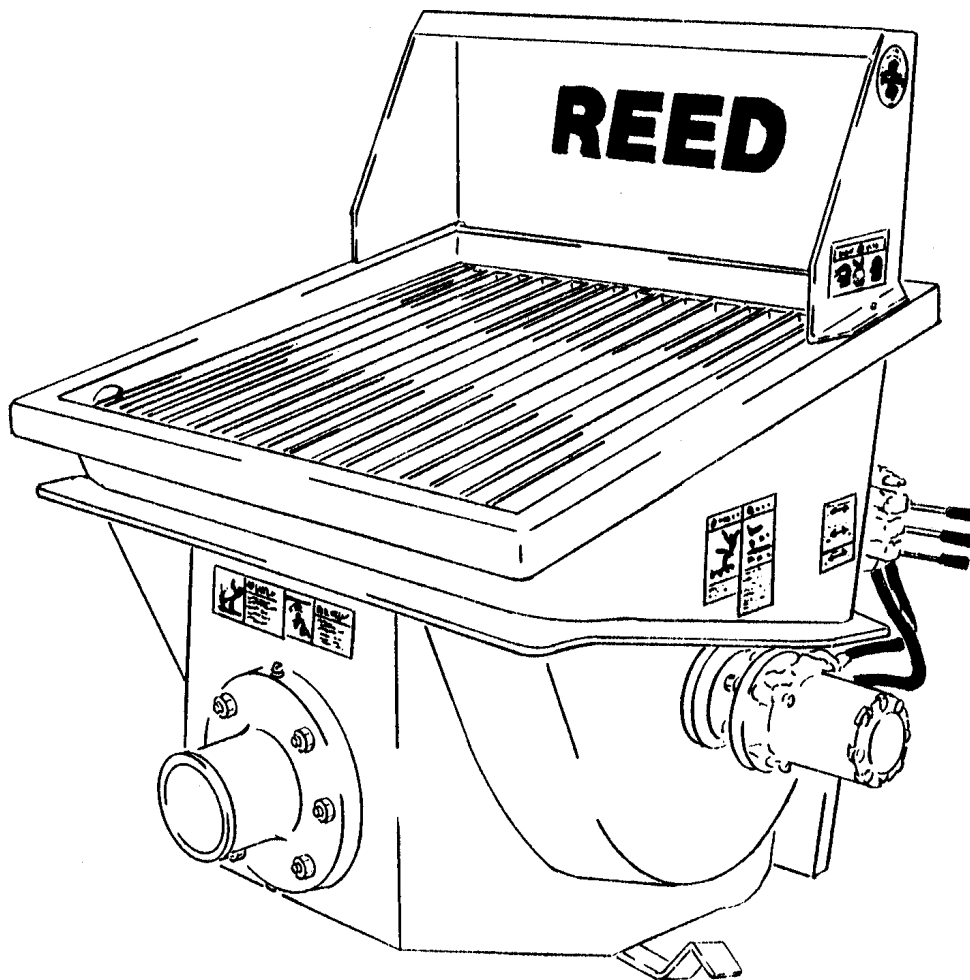



HARSH MIX HOPPER INSTALLATION

01 B70
PARTS
GROUP 20
FIGURE 01
PAGE 01

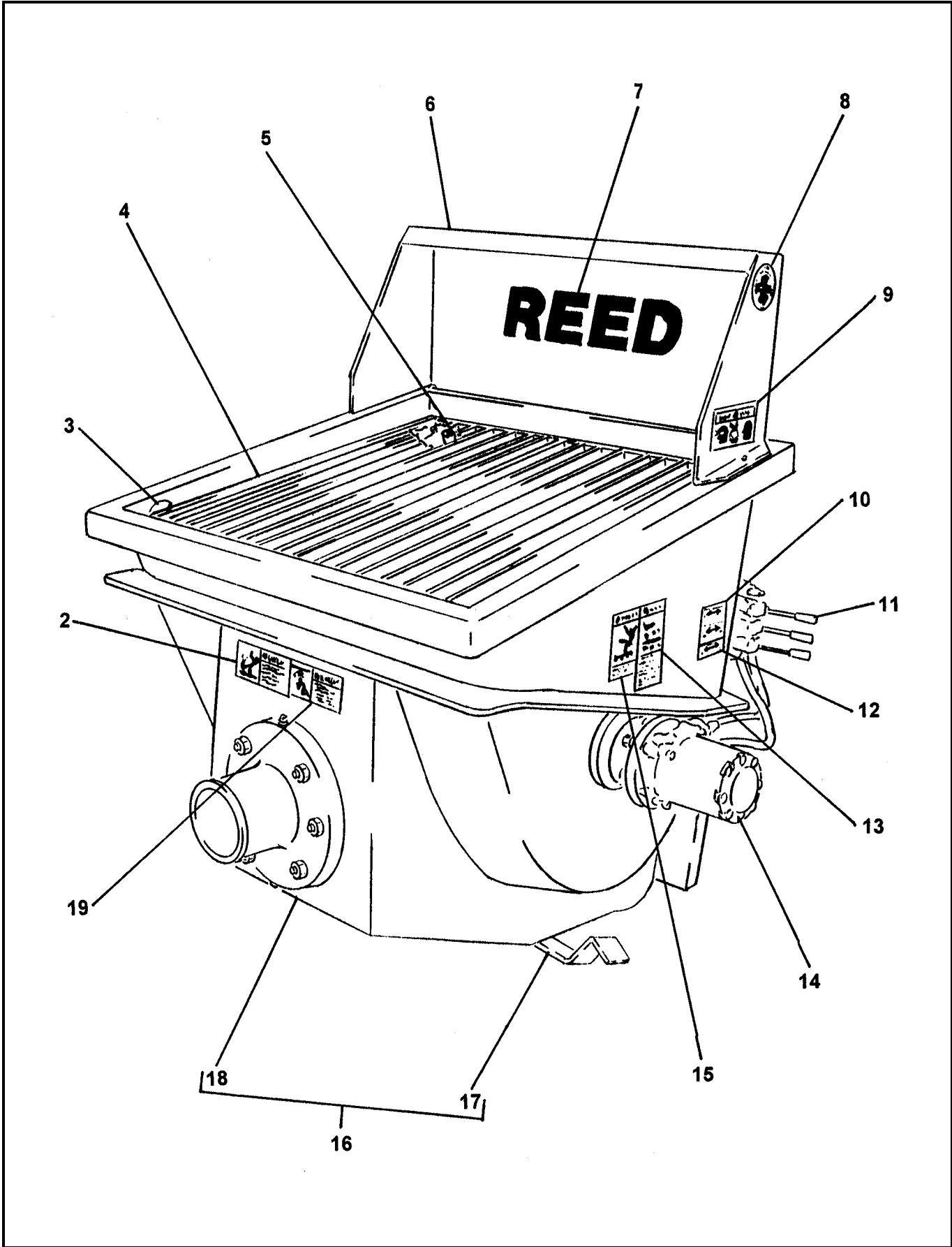

REVISION:



HARSH MIX HOPPER INSTALLATION

01 B70
PARTS
GROUP 20
FIGURE 01
PAGE 02

ITEM NO.	REED'S PARTS NO.	DESCRIPTION	QTY
		1 2 3 4 5	
-1	20-01	Installation, Harsh Mix Hopper (See Group 10, Figure 01 for NHA)	Ref
2	800922	• Decal, Warning, Before Opening a Blocked Pipeline,	1
3	86118	• Mount, Hopper Grate	2
4	85982	• Grate, Harsh Mix Hopper	1
5	86083	• Bumper, Hopper Grate	2
6	86084	• Weldment, Splash Guard	1
7	73132	• Decal, REED 4 1/2 Inch	1
8	800931	• Decal, ACPA Member	1
9	800929A	• Decal, Warning	2
10	85845	• Decal, Outriggers (Optional Items)	1
11	20-05	• Assembly, 3 Spool Control Valve (See Group 20, Figure 05 for DET)	1
12	85846	• Decal, Agitator	1
13	800917	• Decal, Warning, Keep Hand Out of Hopper and Valve	2
14	86323	• Assembly, Harsh Mix Hopper Agitator (See Group 20, Figure 03 for DET)	1
15	800918	• Decal, Warning, Do Not Stand on Hopper Grate	2
16	85840	• Weldment, Harsh Mix Hopper	1
17	86542	• • Assembly, Clean Out Door (See Group 20, Figure 02 for DET)	1
18	86316	• • Weldment, Harsh Mix Hopper	1
19	800921	• Decal, Warning, Do Not Operate at Pressures Exceeding	1

DASH (-) ITEM NOT ILLUSTRATED

REVISION:



HOPPER CLEAN OUT DOOR ASSEMBLY (ROUNDED)

01 B70

PARTS

GROUP 20

FIGURE 02

PAGE 01

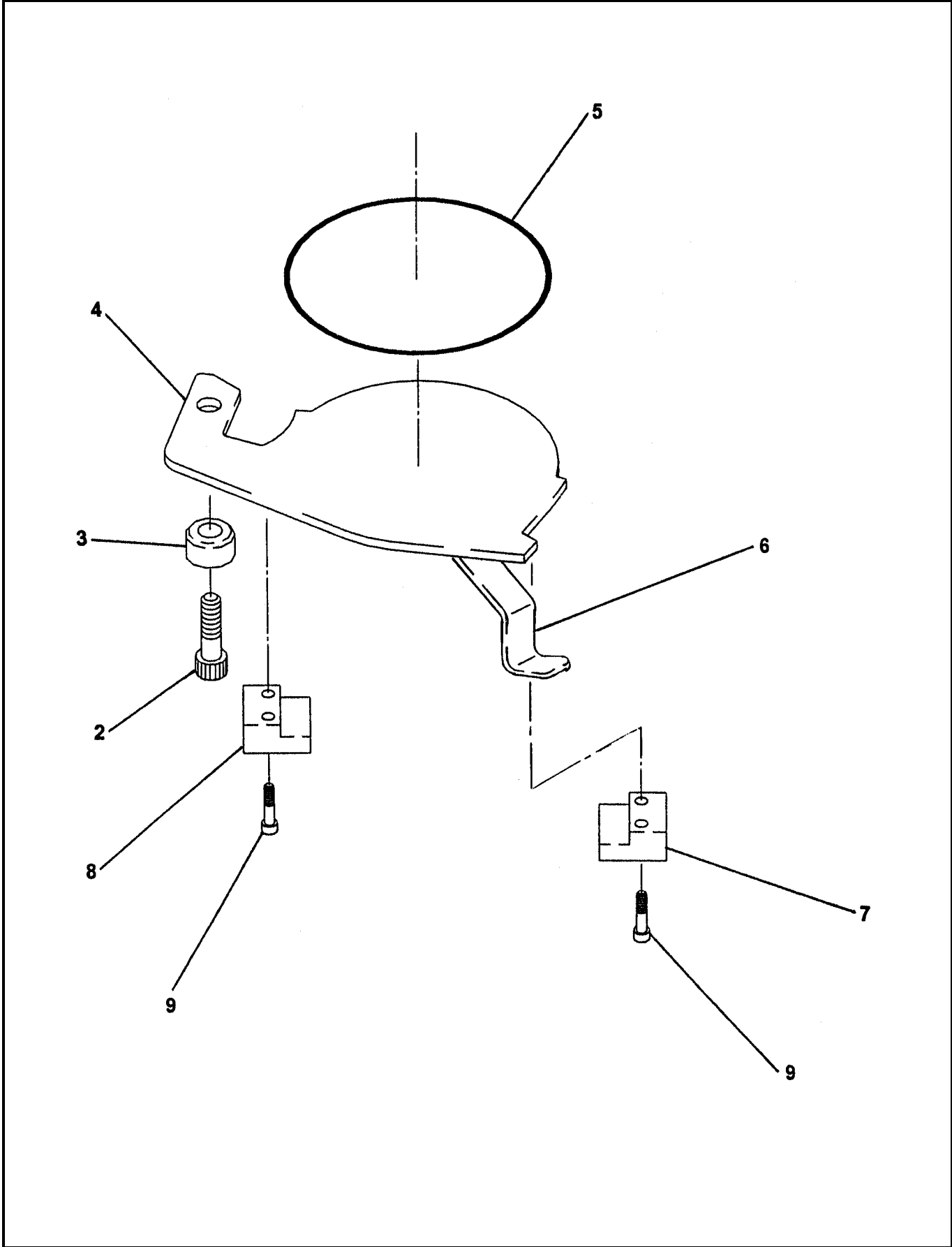

REVISION:



HOPPER CLEAN OUT DOOR ASSEMBLY (ROUNDED)

01 B70

PARTS

GROUP 20

FIGURE 02

PAGE 02

ITEM NO.	REED'S PARTS NO.	DESCRIPTION					QTY
		1	2	3	4	5	
-1	86542	Assembly, Rounded Clean Out Door (See Group 20, Figure 01 for NHA)					Ref
2		• Bolt, Shoulder					1
3	85367	• Boss, Clean Out Door					1
4	86988	• Door, Clean Out					1
5	W-102908A	• Cord, Hopper Door O-Ring 2.21 FT					1
6	86541	• Handle, Clean Out Door					1
7	86560	• Block, RH Clean Out Door					1
8	86599	• Block, LH Clean Out Door					1
9		• Capscrew, Socket Head					4
-10	85312	• Plate, Seal					1
-11	85371	• Neck, Clean Out Door					1

DASH (-) ITEM NOT ILLUSTRATED

REVISION:



HARSH MIX HOPPER AGITATOR ASSEMBLY

01 B70
PARTS
GROUP 20
FIGURE 03
PAGE 01

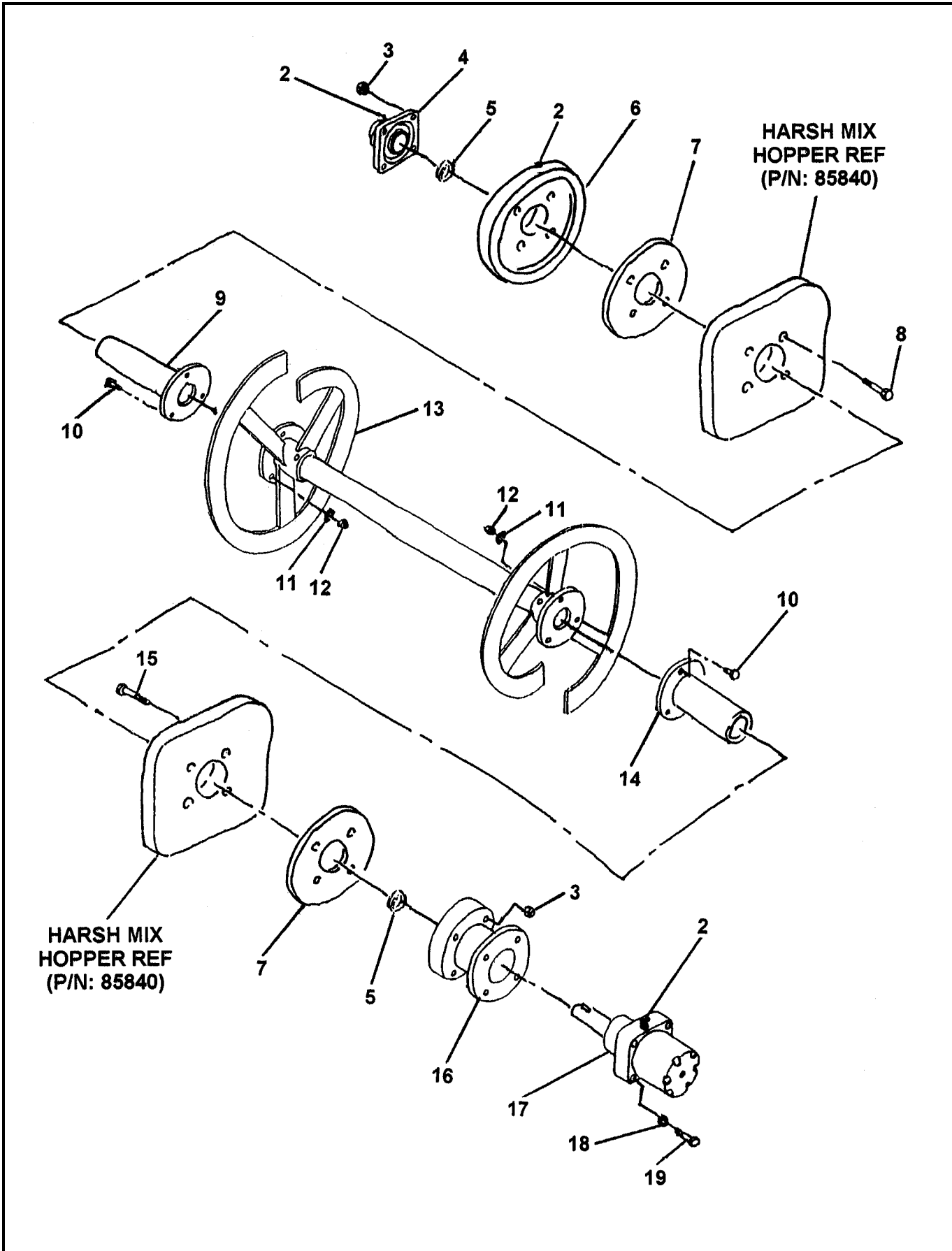

REVISION:



HARSH MIX HOPPER AGITATOR ASSEMBLY

01 B70
PARTS
GROUP 20
FIGURE 03
PAGE 02

ITEM NO.	REED'S PARTS NO.	DESCRIPTION	QTY
		1 2 3 4 5	
-1	86323	Assembly, Harsh Mix Hopper Agitator (See Group 20, Figure 01 for NHA)	Ref
2		• Fitting, Grease 90	3
3		• Nut, Nylock	8
4	86067	• Bearing, Flange	1
5	86074	• Seal, Poly	2
6	86069	• Flange, Agitator Bearing	2
7	77512	• Seal, Auger (Bearing Side)	2
8		• Bolt, Hex	4
9	86066	• Shaft, Agitator Idler	1
10		• Bolt, Hex	6
11		• Washer, Lock	6
12		• Nut, Hex	6
13	86087	• Weldment, Agitator Shaft	1
14	86062	• Shaft, Agitator Drive	1
15		• Bolt, Hex	4
16	86070	• Flange, Motor	1
17	85809	• Assembly, Harsh Mix Hopper Agitator Motor (See Group 20, Figure 04 for DET)	1
18		• Washer, Lock (attaching Parts)	4
19		• Bolt, Coarse (attaching Parts)	4

DASH (-) ITEM NOT ILLUSTRATED

REVISION:



HARSH MIX HOPPER AGITATOR MOTOR ASSEMBLY

01 B70

PARTS

GROUP 20

FIGURE 04

PAGE 01

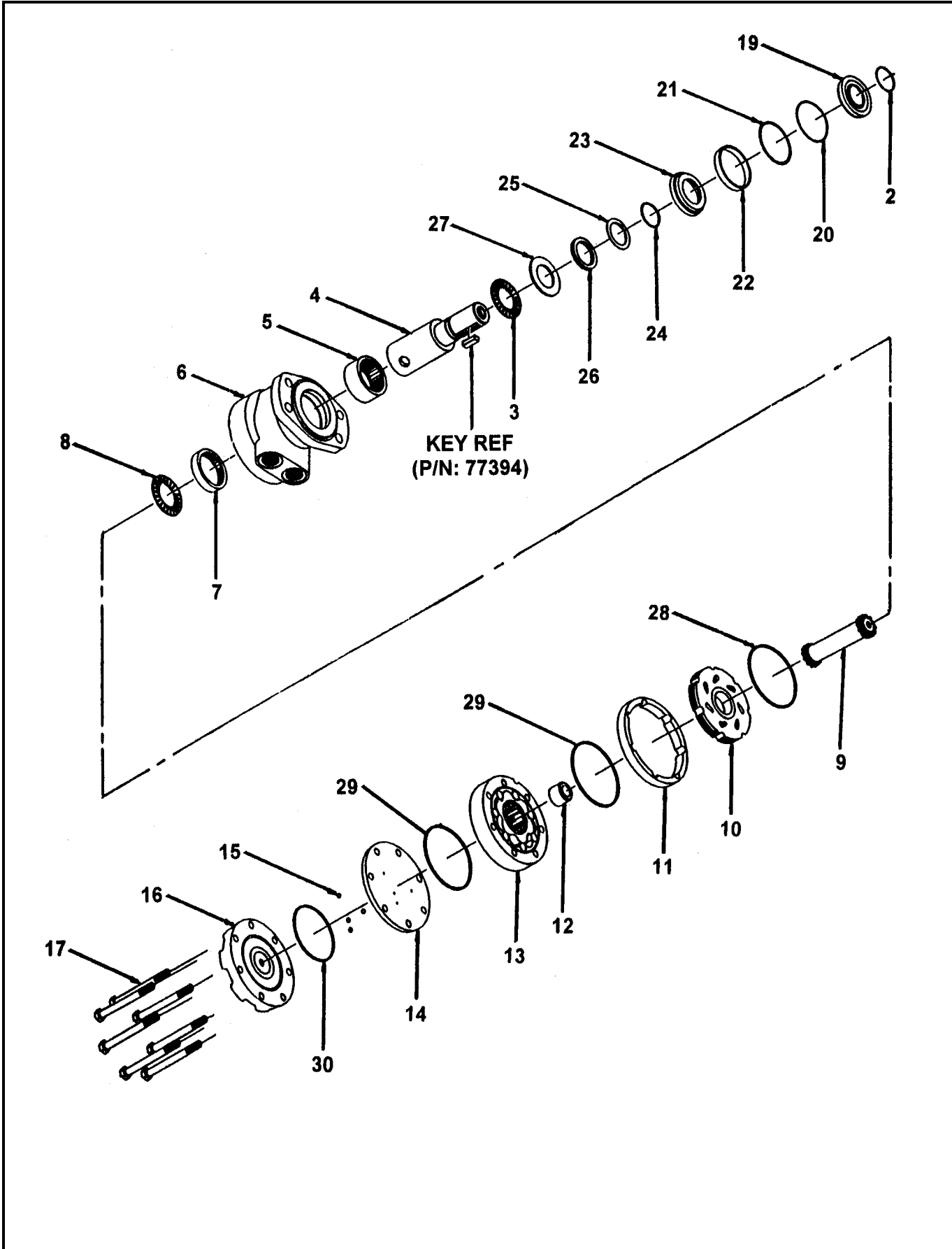

REVISION:



HARSH MIX HOPPER AGITATOR MOTOR ASSEMBLY

01 B70
PARTS
GROUP 20
FIGURE 04
PAGE 02

ITEM NO.	REED'S PARTS NO.	DESCRIPTION	QTY
		1 2 3 4 5	
-1	85809	Assembly, Harsh Mix Hopper Agitator Motor (See Group 20, Figure 03 for NHA)	Ref
2		• Ring, Wire	1
3		• Bearing, Front Thrust	1
4		• Kit, Shaft	1
5		• Bearing, Front Housing	1
6		• Kit, Housing	1
7		• Bearing, Rear Housing	1
8		• Bearing, Rear Thrust	1
9		• Kit, Drive Link	1
10		• Bearing, Front Thrust	1
11		• Manifold	1
12		• Boot, Manifold	1
13		• Kit, Free Turn Rotor	1
14		• Plate, Balance	1
15		• Ball, Steel	4
16		• Cover, Motor End	1
17		• Bolt, Hex (attaching parts)	7
-18	85809SK	• Kit, Seal	1
19		• • Seal, Dust	1
20		• • Ring, Split Wire	1
21		• • Shim, Metal Back Up	1
22		• • Seal, High Pressure	1
23		• • Carrier, Seal	1
24		• • Shim, Metal Back Up	1
25		• • Seal, Polyamid	1
26		• • Seal, Shaft	1
27		• • Washer, Thrust	1
28		• • Seal, Rear Housing	1
29		• • Seal, Body	2
30		• • Seal, End Cover	1

DASH (-) ITEM NOT ILLUSTRATED

REVISION:



3 SPOOL CONTROL VALVE ASSEMBLY

01 B70

PARTS

GROUP 20

FIGURE 05

PAGE 01

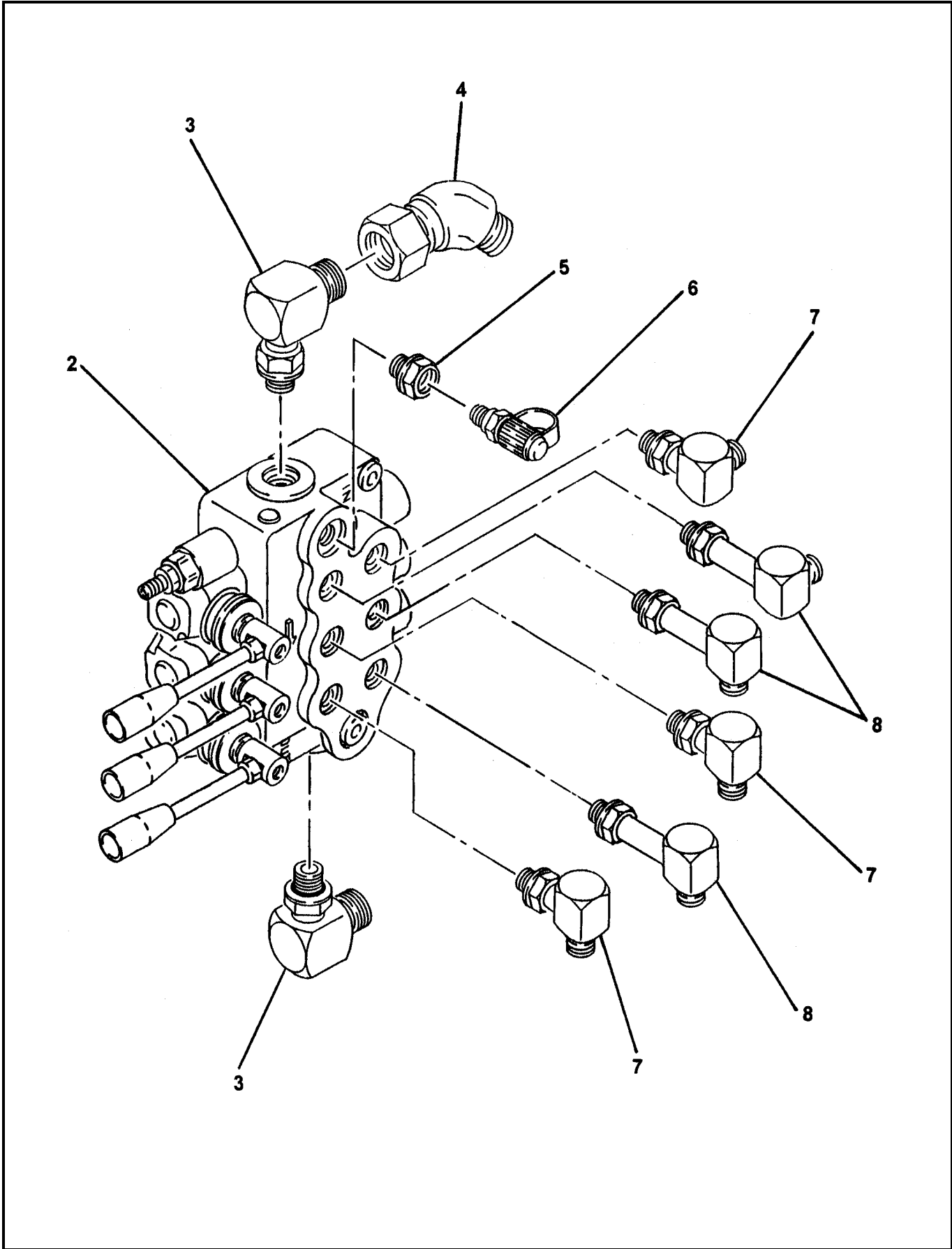

REVISION:



3 SPOOL CONTROL VALVE ASSEMBLY

01 B70

PARTS

GROUP 20

FIGURE 05

PAGE 02

ITEM NO.	REED'S PARTS NO.	DESCRIPTION	QTY
		1 2 3 4 5	
-1	20-05	Assembly, 3 Spool Control Valve (See Group 20, Figure 01 for NHA)	Ref
2	74471	• Sub-Assembly, Agitator Control Valve (See Group 20, Figure 06 for DET)	1
3		• Fitting, 90	2
4		• Swivel, 45	1
5		• Reducer, 8-6	1
6	800083	• Fitting, Mini Check (Port)	1
7		• Fitting, 90	3
8		• Fitting, 90	3
-9		• Bolt, Hex	2
-10		• Washer, SPL Lock	2

DASH (-) ITEM NOT ILLUSTRATED

REVISION:

3 SPOOL CONTROL VALVE SUB-ASSEMBLY

01 B70

PARTS

GROUP 20

FIGURE 06

PAGE 01

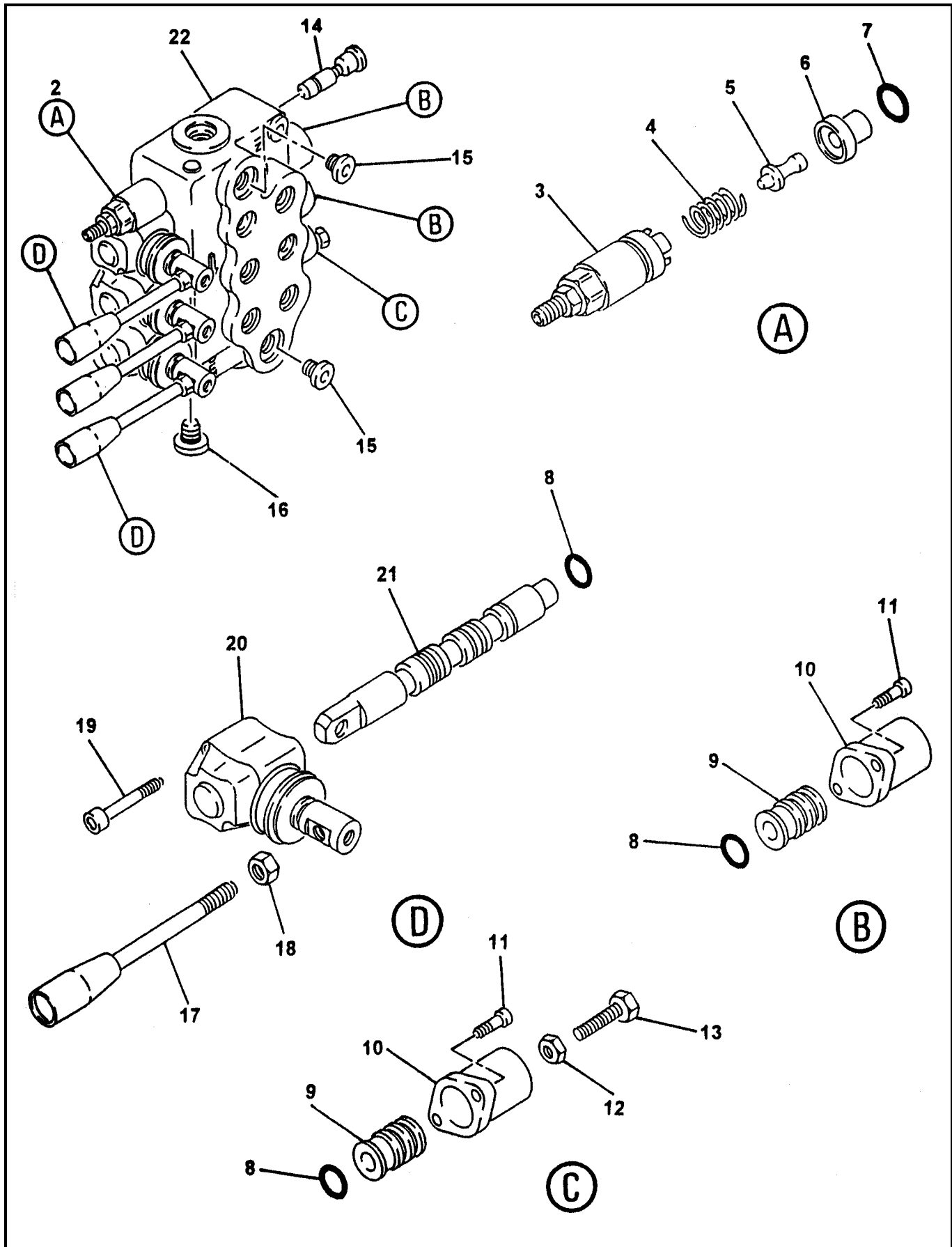

REVISION:



3 SPOOL CONTROL VALVE SUB-ASSEMBLY

01 B70

PARTS

GROUP 20

FIGURE 06

PAGE 02

ITEM NO.	REED'S PARTS NO.	DESCRIPTION					QTY
		1	2	3	4	5	
-1	74471	Sub-Assembly, 3 Spool Control Valve (See Group 20, Figure 05for NHA)					Ref
2	85706	• Cartridge, Relief					1
3		• • Kit, Screw					1
4		• • Spring					1
5		• • Pin, Screw Kit					1
6		• • Ring					1
7		• • O-Ring					1
8		• O-Ring					4
9		• Kit, Spool Control					3
10		• Cap, Spool					3
11		• Screw, SOC (attaching Parts)					6
12		• Nut					1
13		• Bolt, Hex					1
14		• Kit, VRS					1
15		• Plug					2
16		• Plug					1
17		• Handle, Remixer Valve					3
18		• Nut (attaching parts)					3
19		• Screw, SOC					6
20		• Lever, L					3
21		• Spool					3
22		• Body, Valve					1

DASH (-) ITEM NOT ILLUSTRATED

REVISION:

THIS PAGE INTENTIONALLY LEFT BLANK.

REED TRAILER MOUNTED CONCRETE PUMP 01 MODEL B70 ILLUSTRATED PARTS MANUAL GROUP 30 HYDRAULIC TANK INSTALLATION CONTAINS THE FOLLOWING FIGURES:

- FIGURE 00** TABLE OF CONTENTS
- FIGURE 01** TANK INSTALLATION
- FIGURE 02** HYDRAULIC TANK ASSEMBLY
- FIGURE 03** SWING TUBE CIRCUIT MANIFOLD ASSEMBLY
- FIGURE 04** SWING TUBE CIRCUIT MAIN SOLENOID VALVE ASSEMBLY
- FIGURE 05** SWING TUBE CIRCUIT PILOT SOLENOID VALVE ASSEMBLY
- FIGURE 06** BALL VALVE ASSEMBLY
- FIGURE 07** DRIVE CYLINDER CIRCUIT MANIFOLD ASSEMBLY
- FIGURE 08** DRIVE CYLINDER CIRCUIT MAIN SOLENOID VALVE ASSEMBLY
- FIGURE 09** DRIVE CYLINDER CIRCUIT PILOT SOLENOID VALVE ASSEMBLY
- FIGURE 10** ACCUMULATOR ASSEMBLY
- FIGURE 11** ACCUMULATOR BLADDER REPAIR KIT

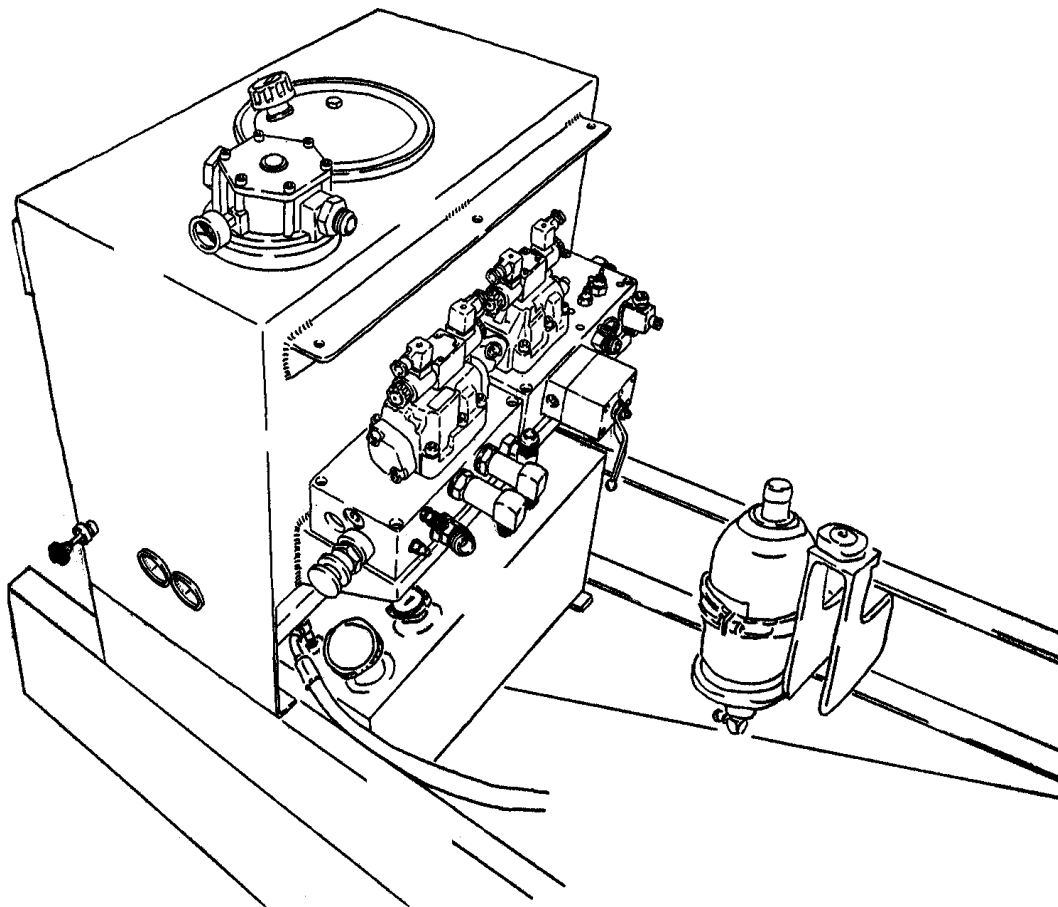



TANK INSTALLATION

01 B70
PARTS
GROUP 30
FIGURE 01
PAGE 01

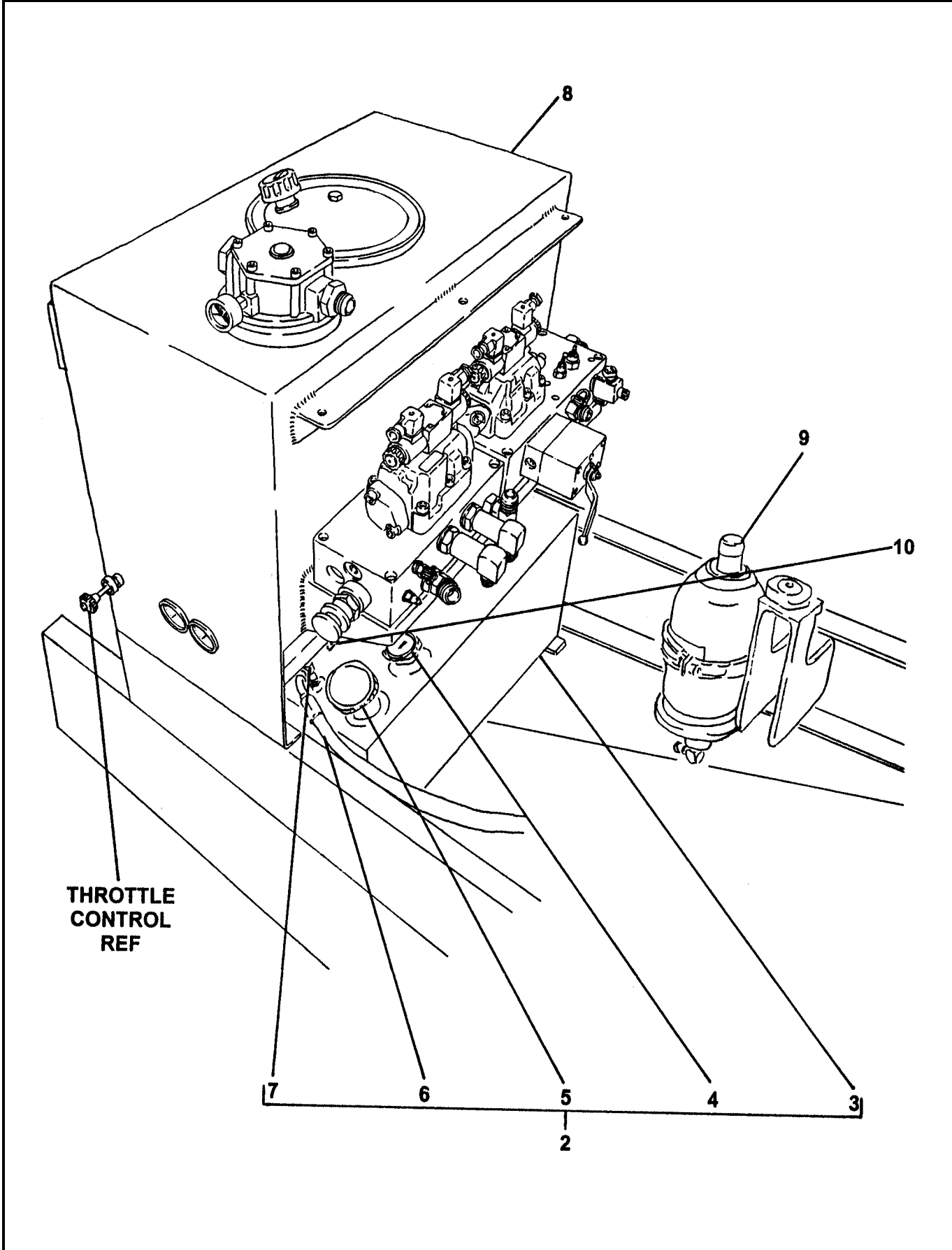

REVISION:



TANK INSTALLATION

01 B70
PARTS
GROUP 30
FIGURE 01
PAGE 02

ITEM NO.	REED'S PARTS NO.	DESCRIPTION	QTY
		1 2 3 4 5	
-1	30-01	Installation, Tank (See Group 10, Figure 01 for NHA)	Ref
2	85363	• Assembly, Fuel Tank	1
3	85111	• • Weldment, Fuel Tank	1
4	85569	• • Gauge, Fuel	1
5	85570	• • Cap, Fuel	1
6	85362	• • Assembly, Fuel Pick Up Tube	2
7		• • Elbow, 90	2
8	85361	• Assembly, Hydraulic Tank (See Group 30, Figure 02 for DET)	1
9	30-10	• Assembly, Accumulator (See Group 30, Figure 10 for DET)	1
10	85815	• Valve, Solenoid	1
-11	85701	• • Cartridge, Solenoid Valve	1
-12	85702	• • Coil, 12 VDC	1
-13	74716	• Hose, 6 Feet Fuel	1
-14	10577	• Clamp, Fuel Hose	2
-15	86365	• Kit, Hose (See SCHEMATIC Section, Page 05 for DET)	1

DASH (-) ITEM NOT ILLUSTRATED



HYDRAULIC TANK ASSEMBLY

01 B70

PARTS

GROUP 30

FIGURE 02

PAGE 01

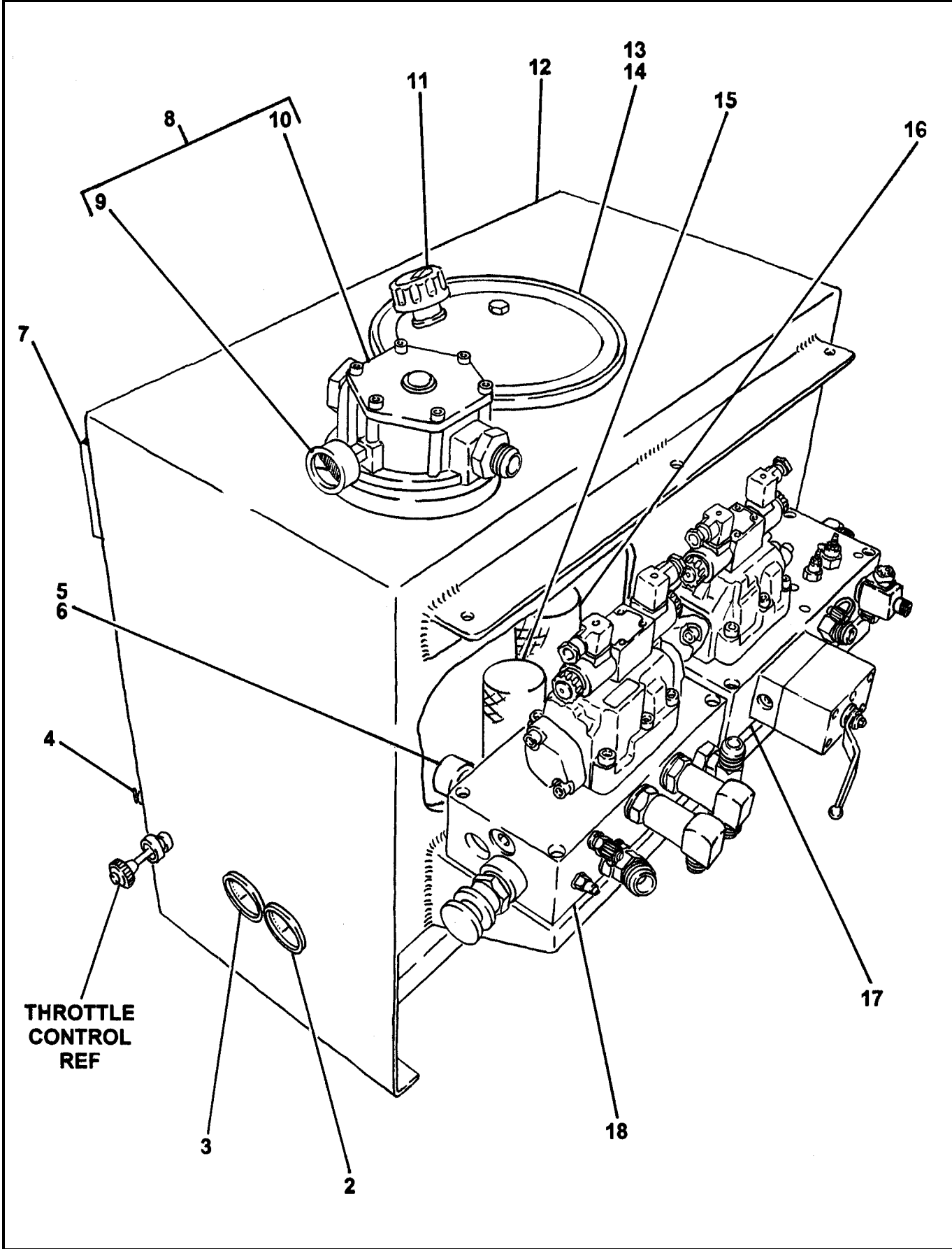

REVISION:



HYDRAULIC TANK ASSEMBLY

01 B70

PARTS

GROUP 30

FIGURE 02

PAGE 02

ITEM NO.	REED'S PARTS NO.	DESCRIPTION					QTY
		1	2	3	4	5	
-1	85361	Assembly, Hydraulic Tank (See Group 30, Figure 01 for NHA)					Ref
2	70366	• Gauge, 3,000 PSI Hydraulic					1
3	74562	• Gauge, 6,000 PSI Hydraulic					1
4	801025	• Cock, Drain					1
5	85574	• Valve, 2 Inch Check					1
6	10981	• Nipple, 2 Inch					1
7	74509	• Gauge, Sight					1
8	85282	• Filter, Return					1
9	85575	• • Gauge, Return Filter					1
10	85283	• • Element, Return Filter					1
11	85537	• Filler, Breather					1
12	85102	• Weldment, Hydraulic Tank					1
13	85824	• • End Cover, Hydraulic Tank					1
14	85867	• • Gasket, End Cover					1
15	79247	• Separator, Magnetic					1
16	800230	• Separator, Magnetic					1
17	85249	• Assembly, Swing Tube Circuit Manifold (See Group 30, Figure 03 for DET)					1
18	85248	• Assembly, Drive Cylinder Circuit Manifold (See Group 30, Figure 07 for DET)					1
-19	78598	• Plug, Hoffman					A/R

DASH (-) ITEM NOT ILLUSTRATED

REVISION:



SWING TUBE CIRCUIT MANIFOLD ASSEMBLY

01 B70
PARTS
GROUP 30
FIGURE 03
PAGE 01

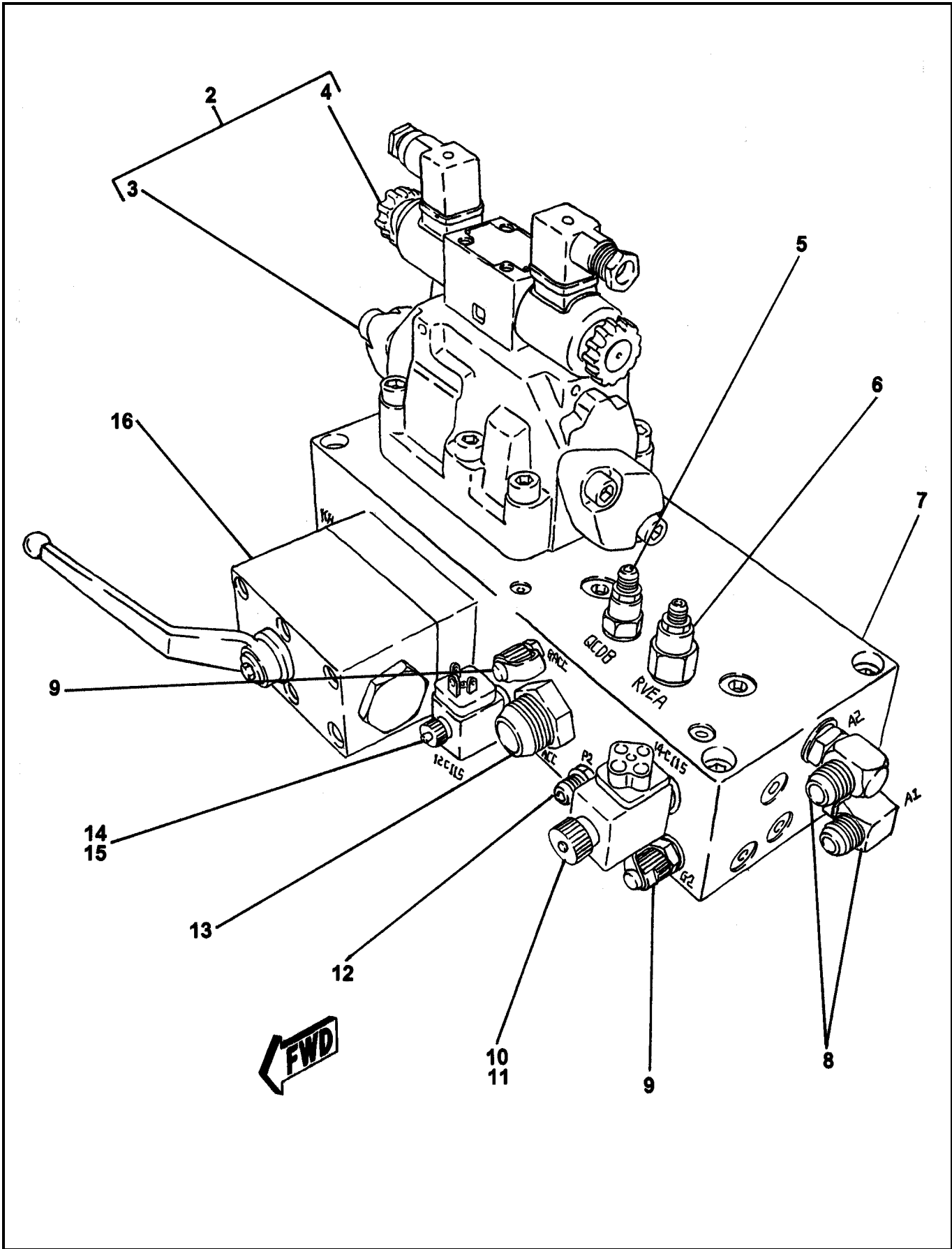

REVISION:



SWING TUBE CIRCUIT MANIFOLD ASSEMBLY

01 B70
PARTS
GROUP 30
FIGURE 03
PAGE 02

ITEM NO.	REED'S PARTS NO.	DESCRIPTION	QTY
		1 2 3 4 5	
-1	85249	Assembly, Swing Tube Circuit Manifold (See Group 30, Figure 02 for NHA)	Ref
2	85693	• Assembly, Swing Tube Circuit Solenoid Valve	1
3	85694	• • Assembly, Swing Tube Circuit Main Solenoid Valve (See Group 30, Figure 04 for DET)	1
4	85695	• • Assembly, Swing Tube Circuit Pilot Solenoid Valve (See Group 30, Figure 05 for DET)	1
5	85704	• Cartridge, Unloader Valve	1
-5A	85704SK	• • Kit, Unloader Valve Cartridge Seal	1
6	85703	• Cartridge, Relief Valve	1
-6A	85703SK	• • Kit, Relief Valve Cartridge Seal	1
7		• Body, Swing Tube Circuit Manifold	1
8		• Elbow, 90	2
9	78593	• Port, Mini Check	2
10	85701	• Cartridge, SV4 Solenoid Valve	1
11	85702	• • Coil, SV4 Solenoid Valve Cartridge	1
12		• Fitting, STR	1
13		• Fitting, STR	1
14	85699	• Cartridge, SV3 Solenoid Valve	1
15	85700	• • Coil, SV3 Solenoid Valve Cartridge	1
16	85705	• Assembly, Ball Valve (See Group 30, Figure 06 for DET)	1

DASH (-) ITEM NOT ILLUSTRATED

REVISION:



SWING TUBE CIRCUIT MAIN SOLENOID VALVE ASSEMBLY

01 B70

PARTS

GROUP 30

FIGURE 04

PAGE 01

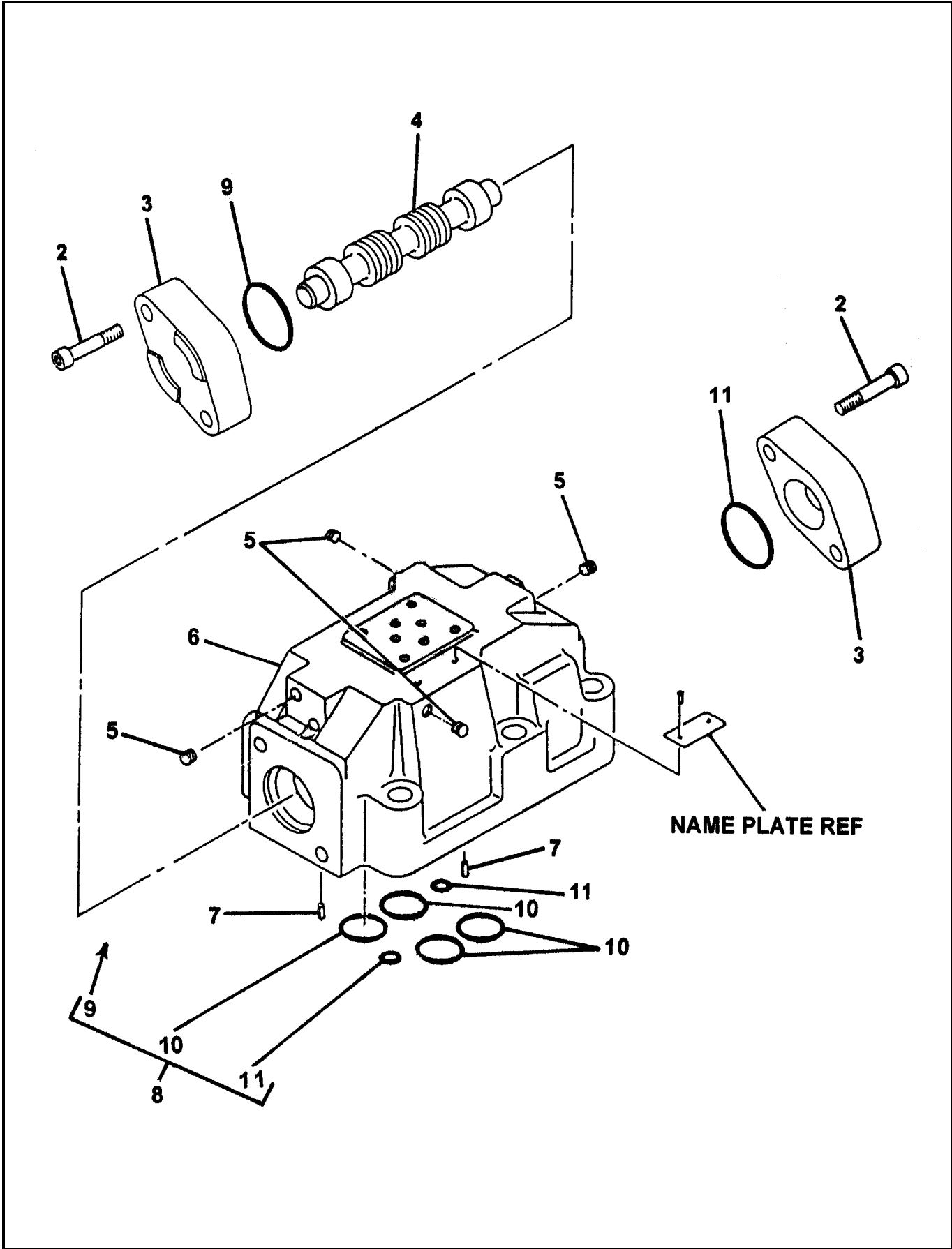

REVISION:



**SWING TUBE CIRCUIT
MAIN SOLENOID VALVE ASSEMBLY**

01 B70
PARTS
GROUP 30
FIGURE 04
PAGE 02

ITEM NO.	REED'S PARTS NO.	DESCRIPTION	QTY
		1 2 3 4 5	
-1	85694	Assembly, Swing Tube Circuit Main Solenoid Valve (See Group 30, Figure 03 for NHA)	Ref
2		• Screw, SOC	4
3		• Cover	2
4		• Spool	1
5		• Plug	4
6		• Housing, Cartridge	1
7		• Pin, Grooved	2
8	74994	• Kit, Seal	1
9		• • O-Ring	2
10		• • • O-Ring	4
11		• • • O-Ring	2

DASH (-) ITEM NOT ILLUSTRATED

SWING TUBE CIRCUIT PILOT SOLENOID VALVE ASSEMBLY

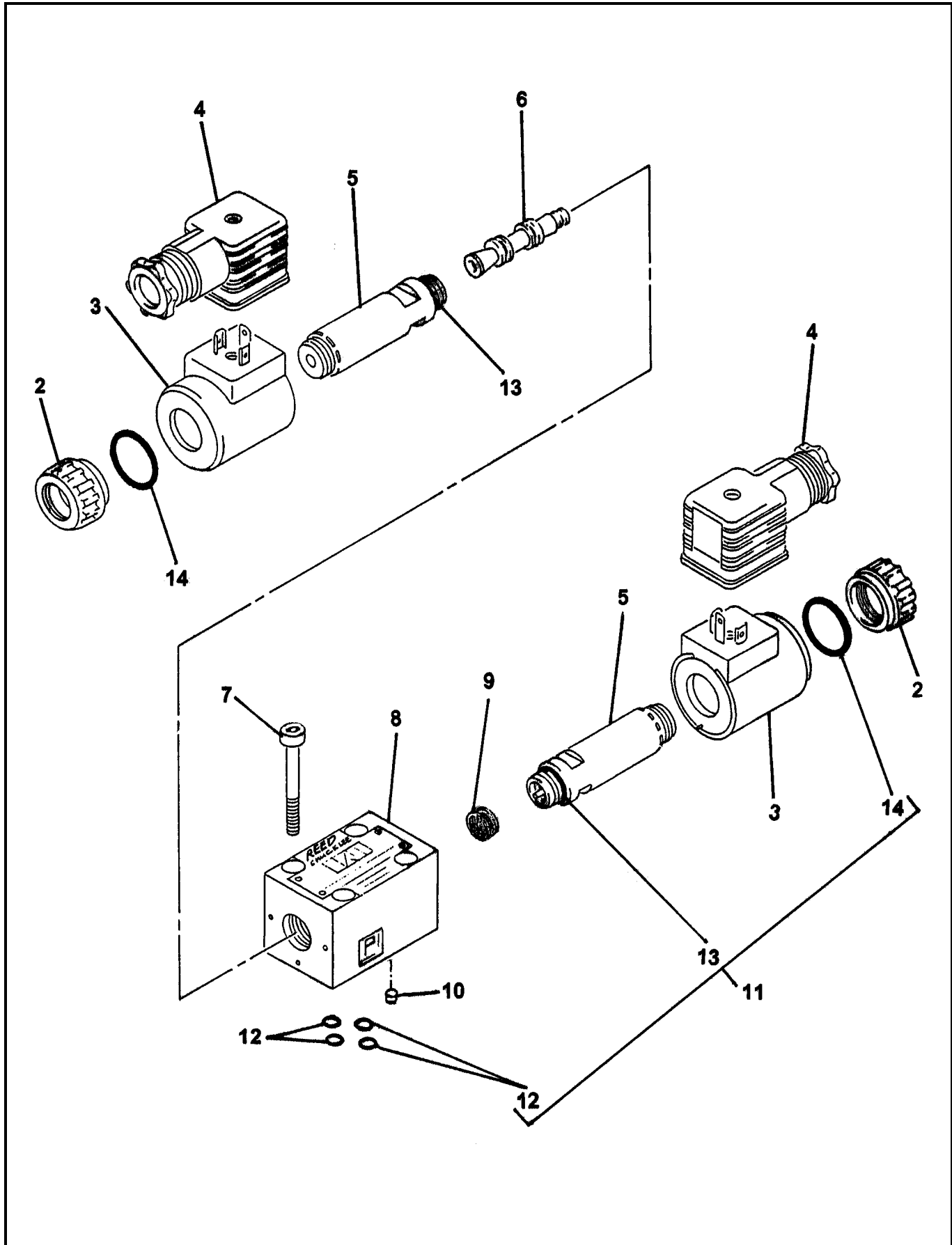

REVISION:



**SWING TUBE CIRCUIT
PILOT SOLENOID VALVE ASSEMBLY**

01 B70
PARTS
GROUP 30
FIGURE 05
PAGE 02

ITEM NO.	REED'S PARTS NO.	DESCRIPTION					QTY
		1	2	3	4	5	
-1	85695	Assembly, Swing Tube Circuit Pilot Solenoid Valve (See Group 30, Figure 03 for NHA)					Ref
2		• Cap, Coil					2
3	85692	• Coil, Solenoid					2
4	74597	• Connector, Plug					2
5		• Amature					2
6		• Spool					1
7		• Screw, SOC					4
8		• Housing, Solenoid Valve					1
9		• Detent					1
10		• Orifice					1
11	72313	• Kit, O-Ring					1
12		• • O-Ring					4
13		• • O-Ring					2
14		• • O-Ring					2

DASH (-) ITEM NOT ILLUSTRATED

REVISION:



BALL VALVE ASSEMBLY

01 B70
PARTS
GROUP 30
FIGURE 06
PAGE 01

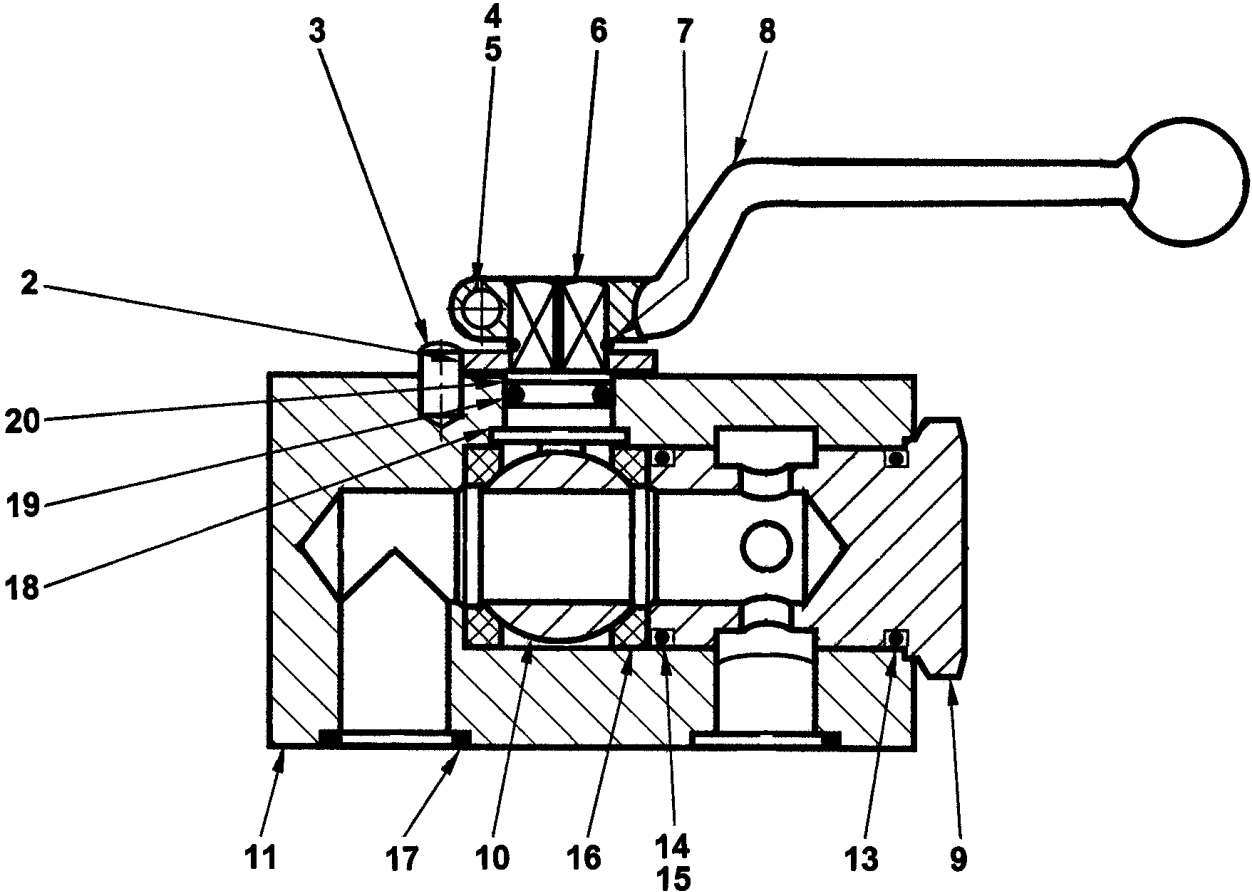

REVISION:



BALL VALVE ASSEMBLY

01 B70

PARTS

GROUP 30

FIGURE 06

PAGE 02

ITEM NO.	REED'S PARTS NO.	DESCRIPTION					QTY
		1	2	3	4	5	
-1	85705	Assembly, Ball Valve (See Group 30, Figure 03 for NHA)					Ref
2		• Washer, Limit					1
3		• Pin, Stop					1
4		• Bolt, Hex					1
5		• Nut, Hex					1
6		• Handle, Control					1
7		• Spindle, Control					1
8		• Retainer, Spring					1
9		• Plug					1
10		• Ball					1
11		• Housing					1
-12		• Kit, Seal					1
13		• • O-Ring					1
14		• • O-Ring					1
15		• • Ring, Back Up					1
16		• • Seal, Bowl					2
17		• • O-Ring					1
18		• • Washer, Thrust					1
19		• • O-Ring					1
20		• • Ring, Back Up					1

DASH (-) ITEM NOT ILLUSTRATED

REVISION:



DRIVE CYLINDER CIRCUIT MANIFOLD ASSEMBLY

01 B70
PARTS
GROUP 30
FIGURE 07
PAGE 01

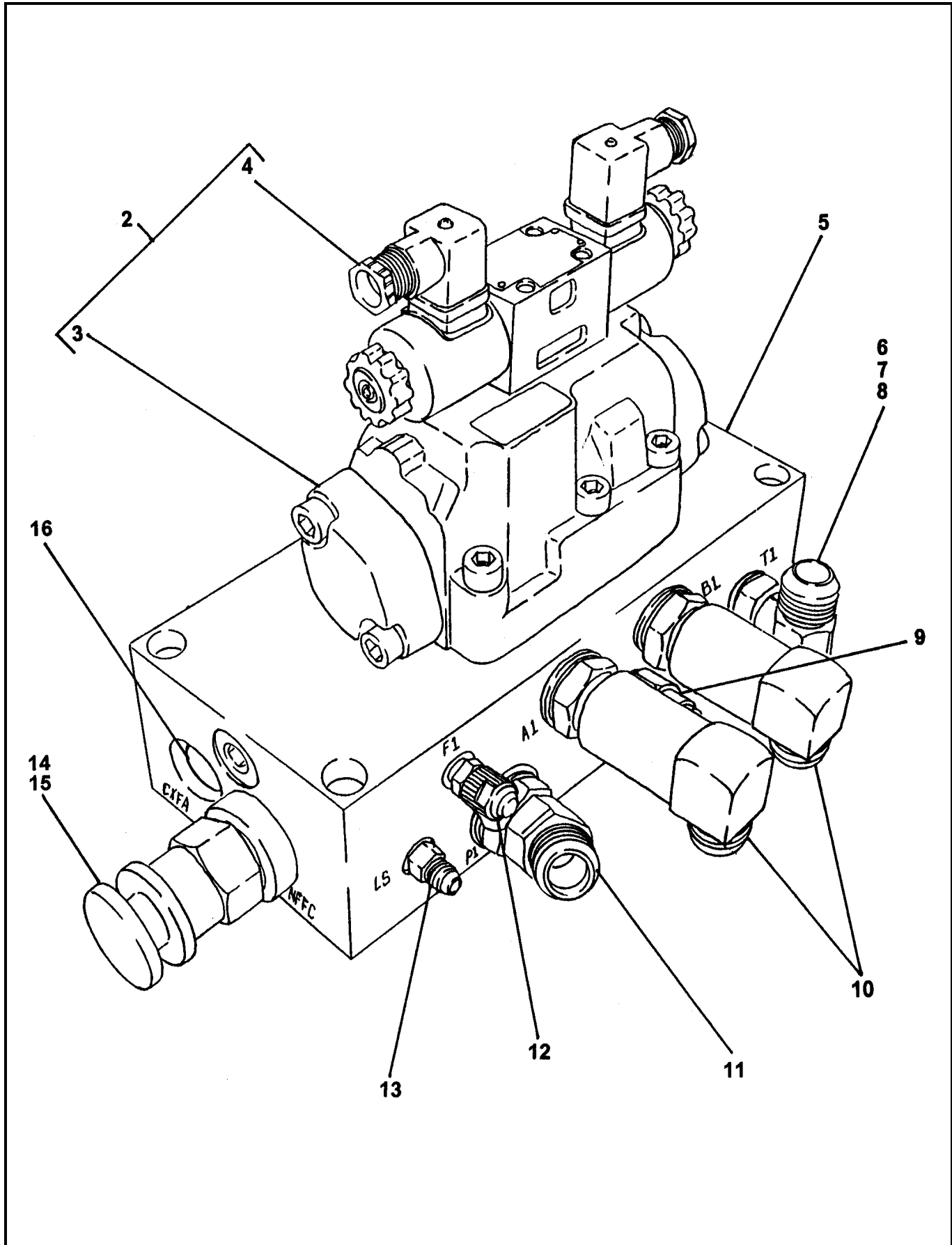

REVISION:



DRIVE CYLINDER CIRCUIT MANIFOLD ASSEMBLY

01 B70
PARTS
GROUP 30
FIGURE 07
PAGE 02

ITEM NO.	REED'S PARTS NO.	DESCRIPTION	QTY
		1 2 3 4 5	
-1	85248	Assembly, Drive Cylinder Circuit Manifold (See Group 30, Figure 02 for NHA)	Ref
2	85689	• Assembly, Drive Cylinder Circuit Solenoid Valve	1
3	85690	• • Assembly, Drive Cylinder Circuit Main Solenoid Valve (See Group 30, Figure 08 for DET)	1
4	85691	• • Assembly, Drive Cylinder Circuit Pilot Solenoid Valve (See Group 30, Figure 09 for DET)	1
5		• Body, Drive Cylinder Circuit Manifold	1
6		• Tee	1
7		• Reducer	1
8		• Plug	1
9	85696	• Cartridge, Relief Valve	1
10		• Elbow, 90	2
11		• Elbow, 45	1
12	78593	• Port, Mini Check	1
13		• Fitting, STR	1
14	85697	• Cartridge, Flow Control Valve	1
15	85697SK	• • Kit, Flow Control Valve Cartridge Seal	1
16	85698	• Cartridge, Check Valve	1

DASH (-) ITEM NOT ILLUSTRATED

REVISION:



DRIVE CYLINDER CIRCUIT MAIN SOLENOID VALVE ASSEMBLY

01 B70
PARTS
GROUP 30
FIGURE 08
PAGE 01

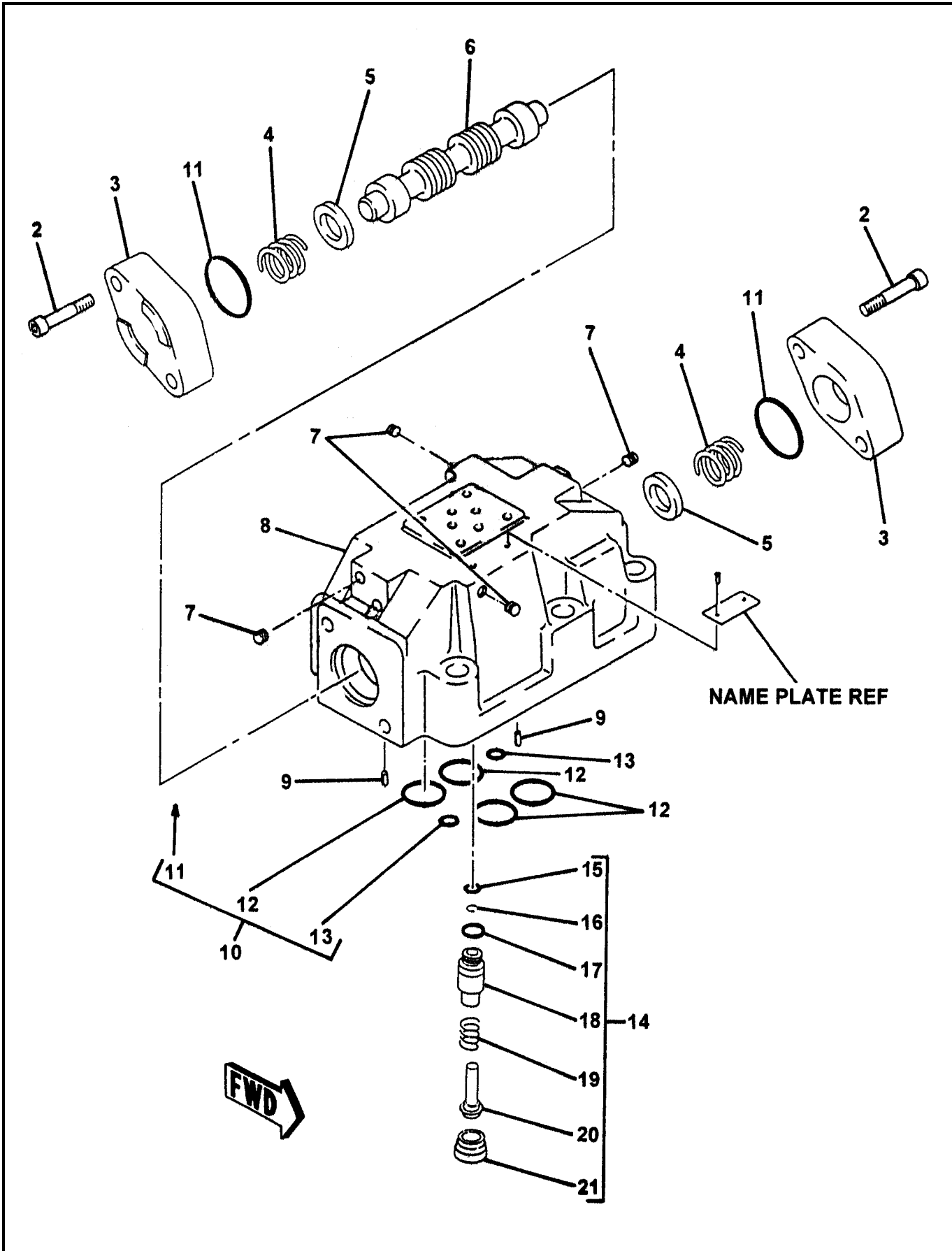

REVISION:



**DRIVE CYLINDER CIRCUIT
MAIN SOLENOID VALVE ASSEMBLY**

01 B70

PARTS

GROUP 30

FIGURE 08

PAGE 02

ITEM NO.	REED'S PARTS NO.	DESCRIPTION	QTY
		1 2 3 4 5	
-1	85690	Assembly, Drive Cylinder Circuit Main Solenoid Valve (See Group 30, Figure 07 for NHA)	Ref
2		• Screw, SOC	4
3		• Cover	2
4		• Spring, Compression	2
5		• Plate, Spring	2
6		• Spool	1
7		• Plug	4
8		• Housing, Cartridge	1
9		• Pin, Grooved	2
10	74994	• Kit, Seal	1
11		• • O-Ring	2
12		• • O-Ring	4
13		• • O-Ring	2
14	73147	• Sub-Assembly, Pilot Pressure Valve	1
15		• • O-Ring	1
16		• • Circlip	1
17		• • O-Ring	1
18		• • Sleeve	1
19		• • Spring, Compression	1
20		• • Cone	1
21		• • Valve, Seat	1

DASH (-) ITEM NOT ILLUSTRATED

REVISION:



DRIVE CYLINDER CIRCUIT PILOT SOLENOID VALVE ASSEMBLY

01 B70
PARTS
GROUP 30
FIGURE 09
PAGE 01

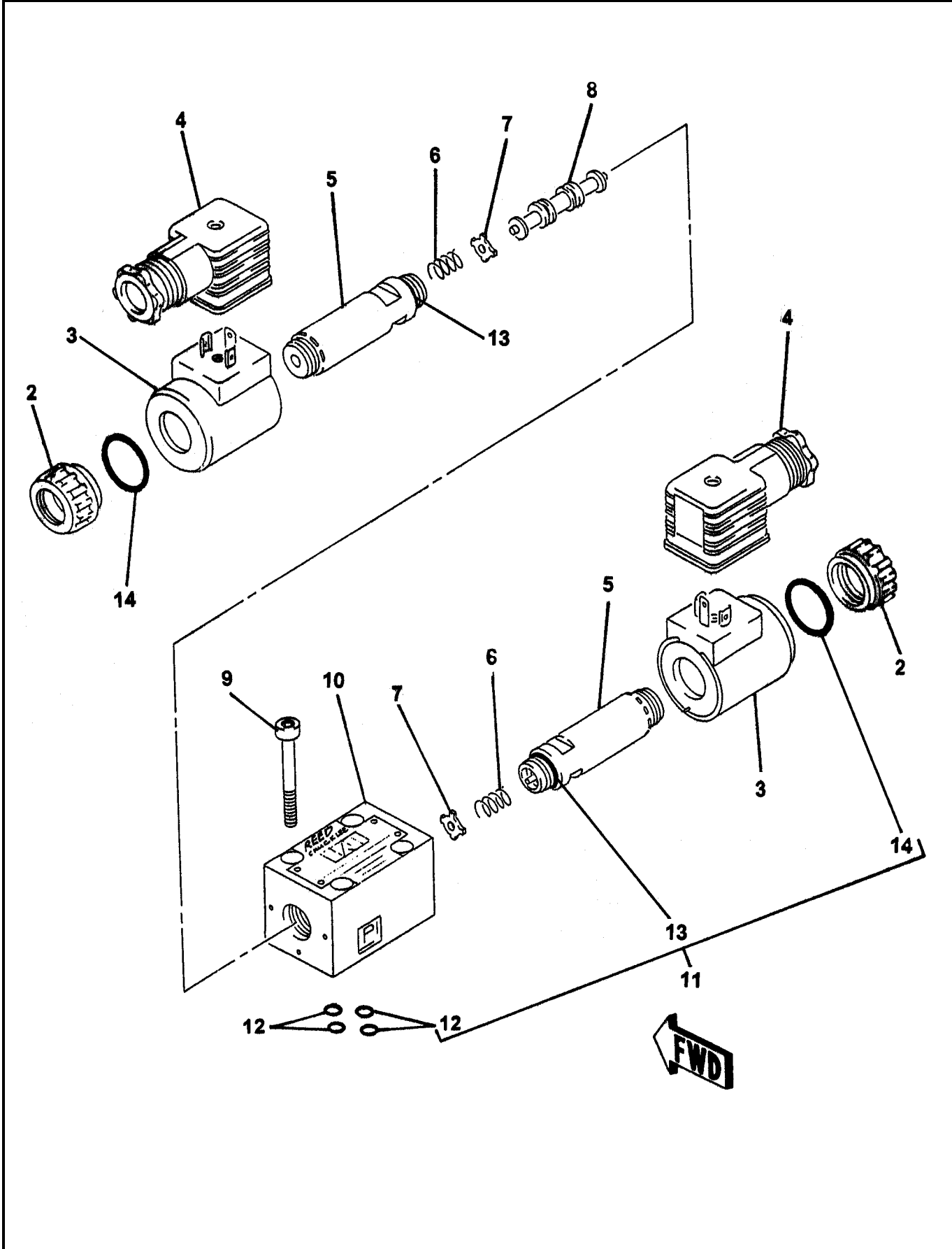

REVISION:



**SWING TUBE CIRCUIT
PILOT SOLENOID VALVE ASSEMBLY**

01 B70
PARTS
GROUP 30
FIGURE 09
PAGE 02

ITEM NO.	REED'S PARTS NO.	DESCRIPTION	QTY
		1 2 3 4 5	
-1	85691	Assembly, Drive Cylinder Circuit Pilot Solenoid Valve (See Group 30, Figure 07 for NHA)	Ref
2		• Cap, Coil	2
3	85692	• Coil, Drive Cylinder Circuit Main Solenoid	2
4	74597	• Connector, Plug	2
5		• Amature	2
6		• Spring	2
7		• Plate, Spring	2
8		• Spool	1
9		• Screw, SOC	4
10		• Housing, Solenoid Valve	1
11	72313	• Kit, O-Ring	1
12		• • O-Ring	4
13		• • O-Ring	2
14		• • O-Ring	2

DASH (-) ITEM NOT ILLUSTRATED

REVISION:

ACCUMULATOR ASSEMBLY

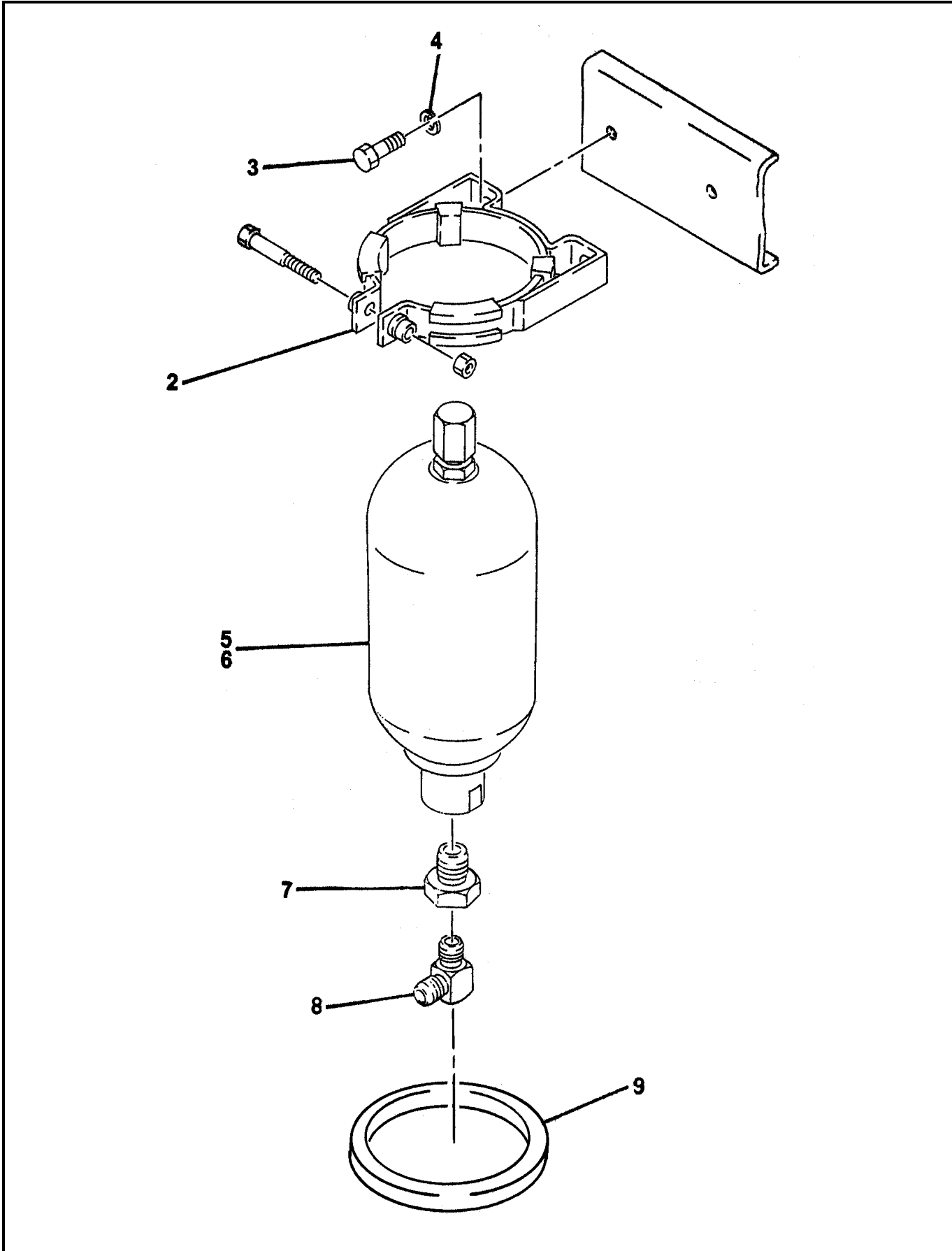

REVISION:



ACCUMULATOR ASSEMBLY

01 B70

PARTS

GROUP 30

FIGURE 10

PAGE 02

ITEM NO.	REED'S PARTS NO.	DESCRIPTION					QTY
		1	2	3	4	5	
-1	30-10	Assembly, Accumulator (See Group 30, Figure 01 for NHA)					Ref
2	73171	• Bracket, Accumulator					1
3		• Bolt, Hex (attaching parts)					2
4		• Washer, Lock (attaching parts)					2
5	74515	• Accumulator, 1 Gal					1
6	30-11	• Kit, Bladder Repair (See Group 30, Figure 11 for REF)					1
7		• Reducer					1
8		• Elbow, 90					1
9	801028	• Grommet, Accumulator					1
-10	71460	• Kit, Accumulator Charge (See Group 80, Figure 07 for REF)					Ref

DASH (-) ITEM NOT ILLUSTRATED

REVISION:



ACCUMULATOR BLADDER REPAIR KIT

01 B70

PARTS

GROUP 30

FIGURE 11

PAGE 01

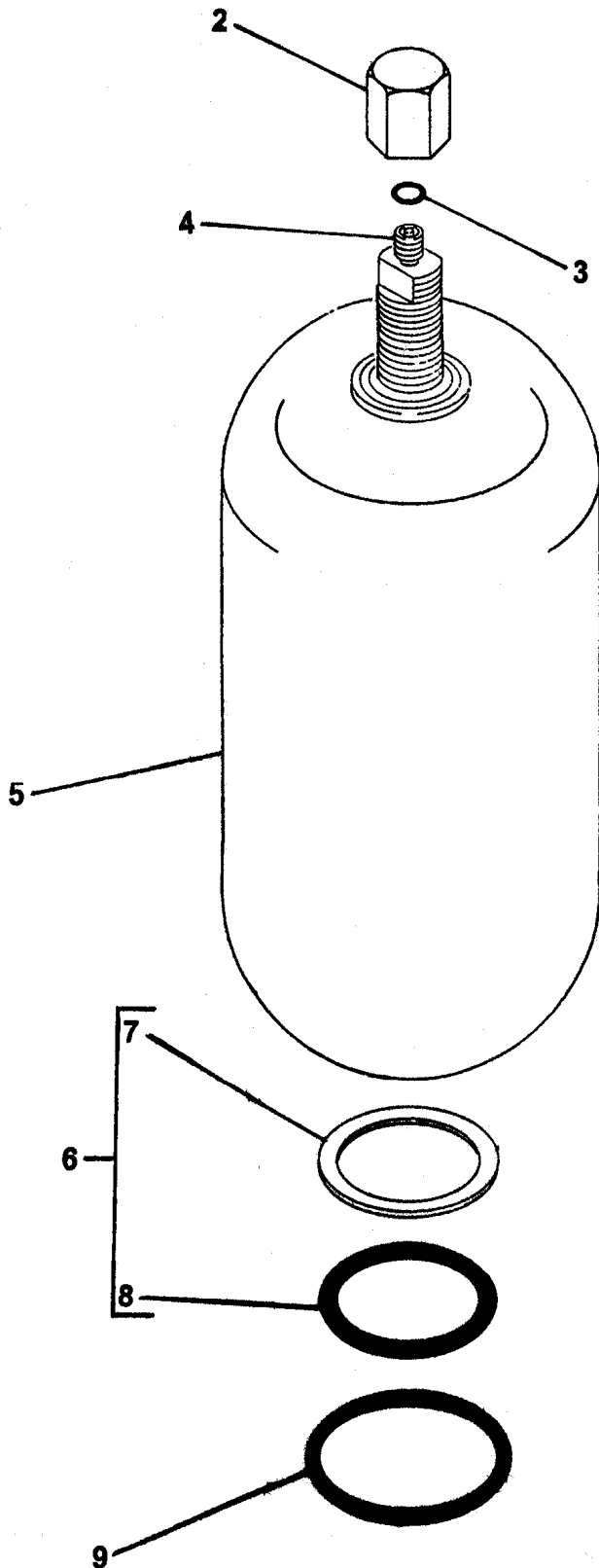

REVISION:



ACCUMULATOR BLADDER REPAIR KIT

01 B70

PARTS

GROUP 30

FIGURE 11

PAGE 02

ITEM NO.	REED'S PARTS NO.	DESCRIPTION	QTY
		1 2 3 4 5	
-1	30-11	Kit, Bladder Repair (Also See Group 30, Figure 10 for NHA)	Ref
2		• Cap, Valve Seal	1
3		• O-Ring	1
4		• Core, Gas Valve	1
5	74516	• Bladder, 1 Gal	1
6	85812	• Kit, Bladder Seal	1
7		• • Ring, Flat	1
8		• • O-Ring	1
9		• Ring, Back Up	1

DASH (-) ITEM NOT ILLUSTRATED

REVISION:

THIS PAGE INTENTIONALLY LEFT BLANK.

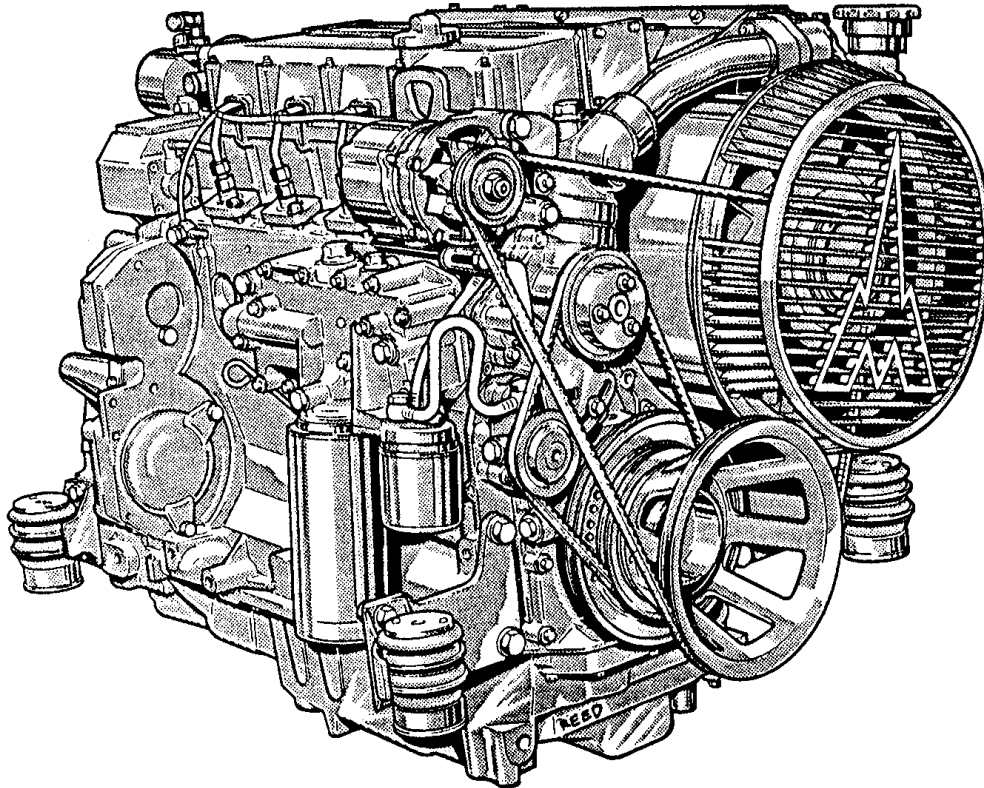

REED TRAILER MOUNTED CONCRETE PUMP 01 MODEL **B70** ILLUSTRATED PARTS MANUAL GROUP 40 POWER TRAIN INSTALLATION CONTAINS THE FOLLOWING FIGURES:

- FIGURE 00** TABLE OF CONTENTS
- FIGURE 01** POWER TRAIN INSTALLATION
- FIGURE 02** HYDRAULIC PUMPS ASSEMBLY
- FIGURE 03** SINGLE AUXILIARY PUMP ASSEMBLY
- FIGURE 04** DOUBLE AUXILIARY PUMP ASSEMBLY
- FIGURE 05** MAIN PUMP ASSEMBLY
- FIGURE 06** BATTERY MOUNTING ASSEMBLY



POWER TRAIN INSTALLATION

01 B70

PARTS

GROUP 40

FIGURE 01

PAGE 01

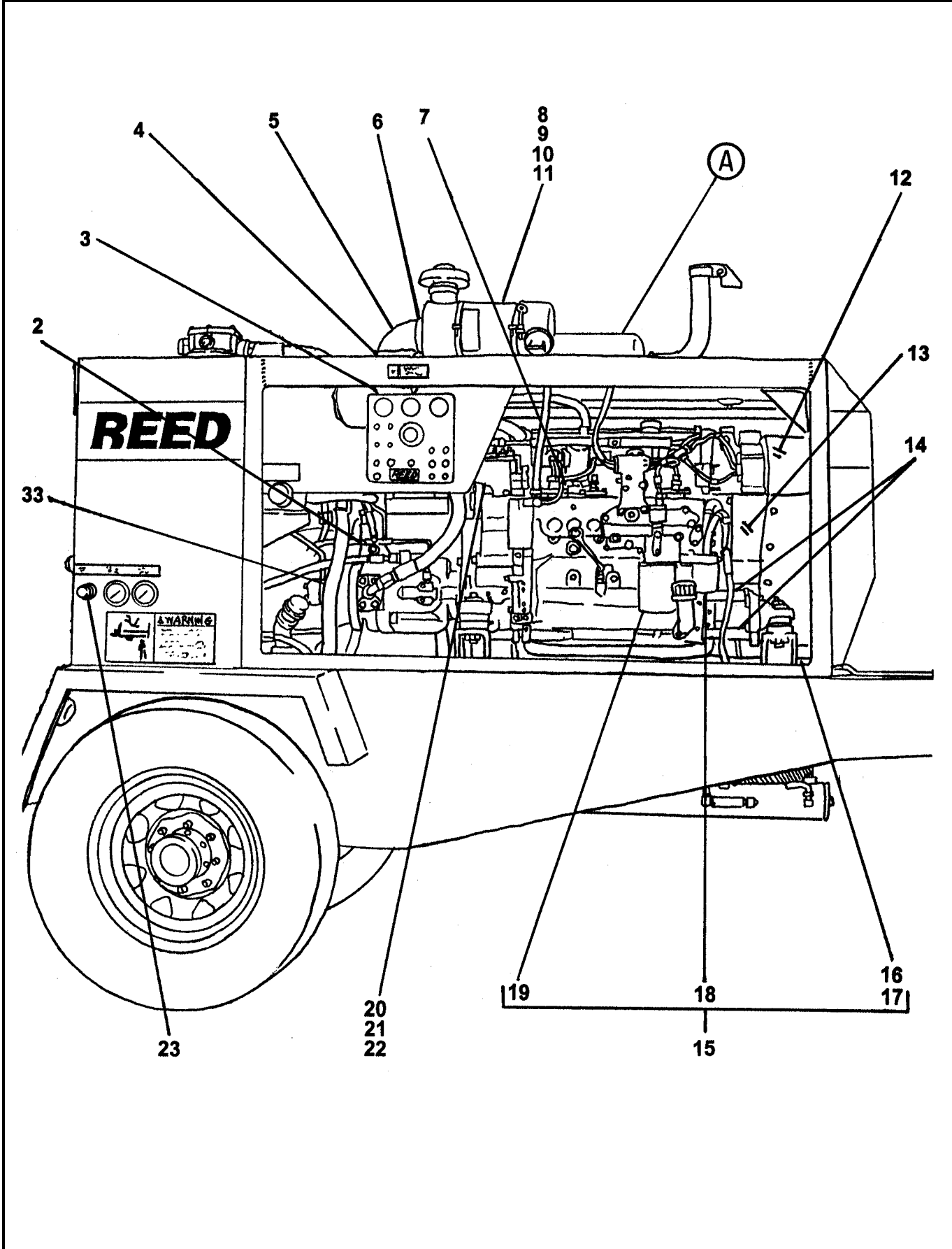

REVISION:



POWER TRAIN INSTALLATION

01 B70
PARTS
GROUP 40
FIGURE 01
PAGE 02

ITEM NO.	REED'S PARTS NO.	DESCRIPTION	QTY
		1 2 3 4 5	
-1	40-01	Installation, Power Train (See Group 10, Figure 01 for NHA)	Ref
2	40-02	• Assembly, Main and Auxiliary Pumps (See Group 40, Figure 02 for DET)	1
3	78195	• Elbow, 4 Inch Rubber	1
4	77477	• Clamp	4
5	74256	• Elbow, 3 to 4 Inch	1
6	74461	• Clamp	1
7	10577	• Clamp, Hose	2
8	74273	• Cleaner, Air	1
-8A	78243	• • Element, Air Cleaner	1
9	78192	• Hood, Inlet	1
10	78193	• Band, Mounting	2
11	85728	• Tube, Air Cleaner	2
11A	85348	• Switch, 12 VDC Solenoid	1
12	72226	• Ring, Air Guide	1
13	85345	• Guard, Small Engine Belt	1
14	72493	• Spacer	2
15	78190	• Assembly, Engine (See Vendor Section, Figure 01 for REF)	1
16	76951	• • Filter, Water Separator	1
-16A	79794	• • • Element, Water Separator Filter	1
17	74716	• • Hose, 6 Feet Fuel	1
18	74500	• • Element, Oil Filter	1
19	72960	• • Element, Fuel Filter	1
20	85779	• Bracket, Start Solenoid	1
21	78202	• Coupler, Throttle Cable	1
22	72294	• Bolt, Throttle Control	1
23	78201	• Cable, Throttle Control	1
33	85426	• Tube, Hydraulic Cylinders	2

DASH (-) ITEM NOT ILLUSTRATED

REVISION:



POWER TRAIN INSTALLATION

01 B70

PARTS

GROUP 40

FIGURE 01

PAGE 03

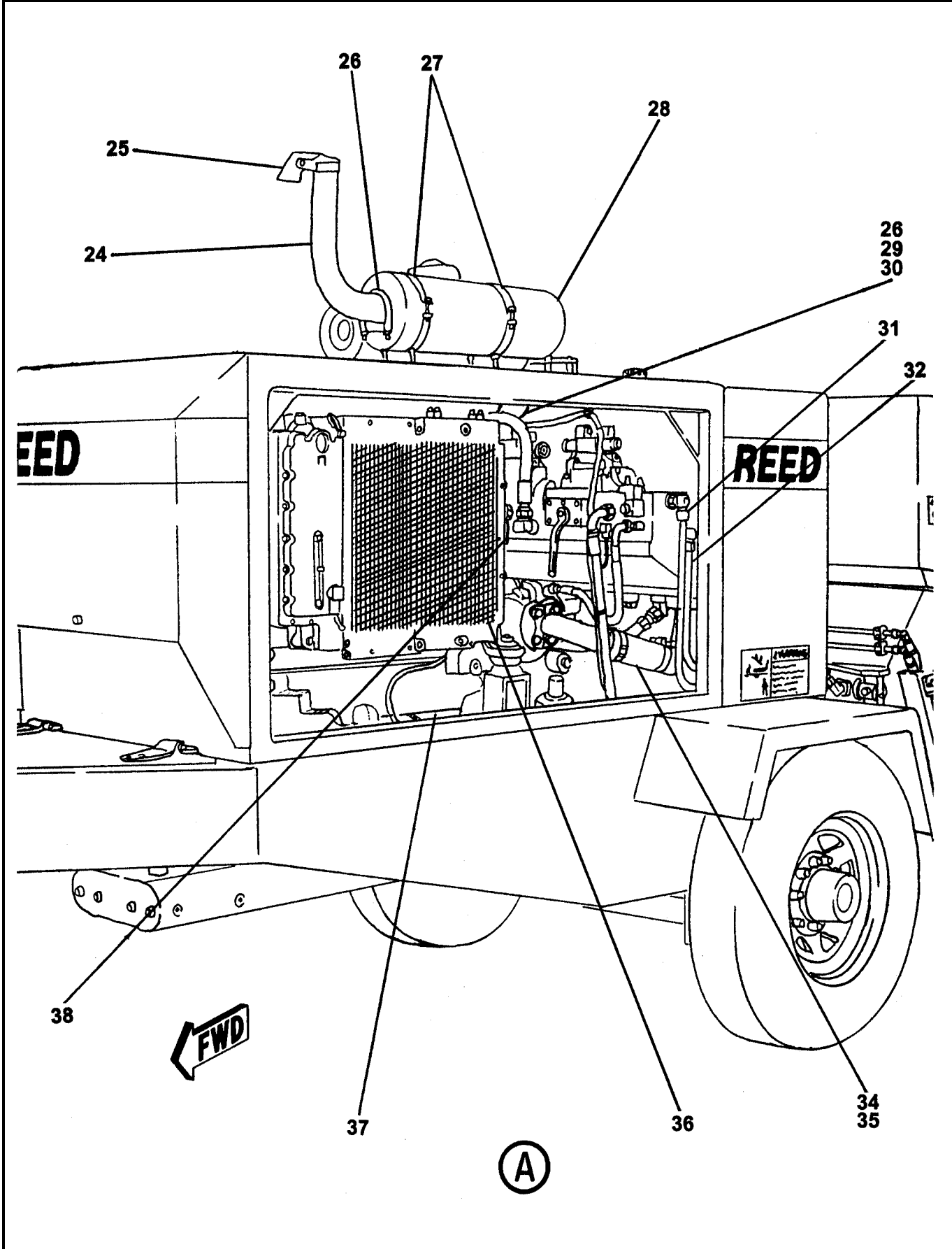

REVISION:



POWER TRAIN INSTALLATION

01 B70

PARTS

GROUP 40

FIGURE 01

PAGE 04

ITEM NO.	REED'S PARTS NO.	DESCRIPTION					QTY
		1	2	3	4	5	
24	78212	• Elbow, Exhaust					1
25	70849	• Cap, Rain					1
26	78213	• Clamp					2
27	78211	• Band, Air Cleaner Mounting					2
28	78199	• Muffler, Oval					1
29	85741	• Elbow, Exhaust					1
30	76524	• Spacer, Exhaust					4
31	85429	• Tube, Hydraulic Shift Cylinder					1
32	85428	• Tube, Hydraulic Shift Cylinder					1
33	85426	• Tube, Hydraulic Cylinders					2
34	85661-001	• Hose, Main Pump Suction					1
35	74310	• Clamp, Severe Service					1
36	85732	• Adapter, Suction					1
37	85670	• Guard, Cooler					1
38	40-06	• Assembly, Battery Mounting (See Group 40, Figure 06 for DET)					1
39	78256	• Bracket, Intake					1
-40	73269	• Strap, Ground					1
-41	85396	• Assembly, Engine Wiring Harness (See Schematic Section, Page 11 for REF)					1

DASH (-) ITEM NOT ILLUSTRATED

REVISION:

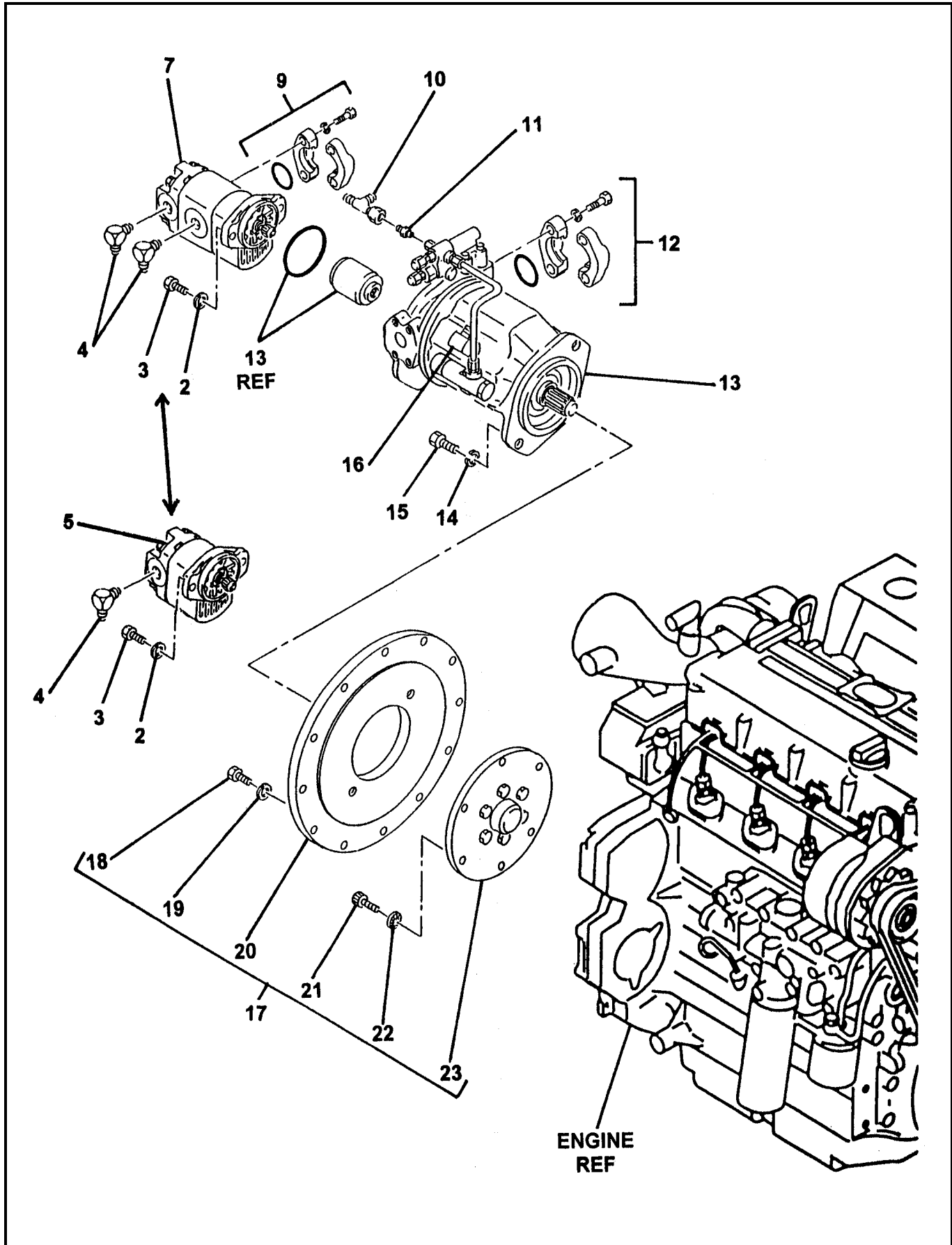



HYDRAULIC PUMPS ASSEMBLY

01 B70

PARTS

GROUP 40

FIGURE 02

PAGE 02

ITEM NO.	REED'S PARTS NO.	DESCRIPTION	QTY
		1 2 3 4 5	
-1	40-02	Assembly, Hydraulic Pump (See Group 40, Figure 01 for NHA)	Ref
2		• Washer, Lock	2
3		• Bolt, Hex	2
4		• Fitting, 90	A/R
5	72978	• Assembly, Single Auxiliary Pump (See Group 40, Figure 04 for DET)	1
-6	85675	• Assembly, Optional Pump	1
7	73156	• • Assembly, Double Auxiliary Pump (See Group 40, Figure 03 for DET)	1
-8	85652	• • Valve, Solenoid	1
9		• Kit, Flange	1
10		• Fitting, Tee	1
11		• Fitting STR	1
12		• Kit, Flange	1
13	85124	• Assembly, Main Pump (See Group 40, Figure 05 for DET) (Also See Vendor Section, Figure 02 for REF)	1
14		• Washer, Lock (attaching parts)	2
15		• Bolt, Hex (attaching parts)	2
16		• Fitting, 90	1
17	85126	• Assembly, Flywheel Coupling	1
18		• • Bolt, Hex	12
19		• • Washer, SPL	12
20		• • Plate, Flywheel	1
21		• • Screw	6
22		• • Washer	6
23		• • Drive, Flywheel	1
-24	78256	• Bracket, Air Intake	1

DASH (-) ITEM NOT ILLUSTRATED

REVISION:



SINGLE AUXILIARY PUMP ASSEMBLY

01 B70
PARTS
GROUP 40
FIGURE 03
PAGE 01

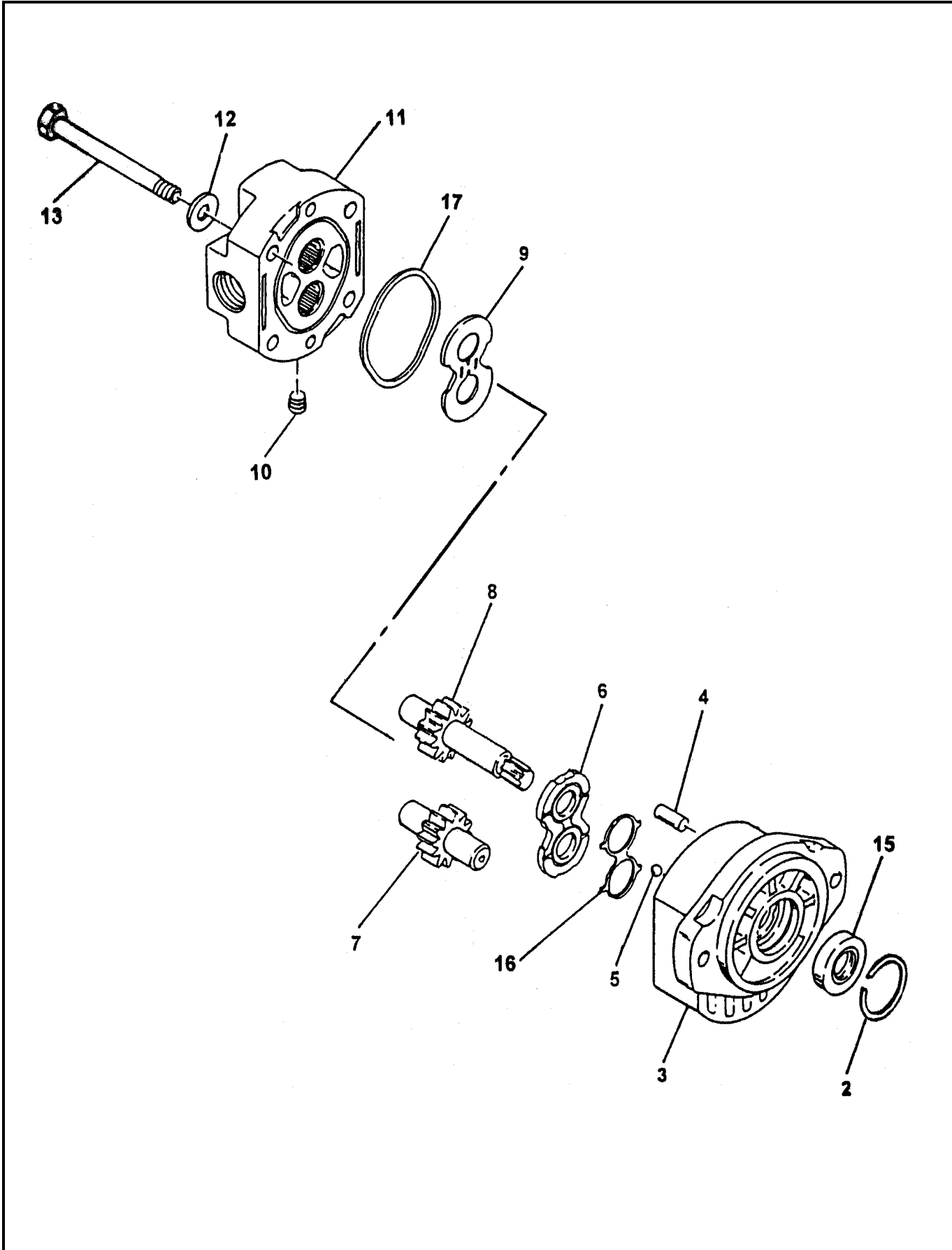

REVISION:



SINGLE AUXILIARY PUMP ASSEMBLY

01 B70

PARTS

GROUP 40

FIGURE 03

PAGE 02

ITEM NO.	REED'S PARTS NO.	DESCRIPTION					QTY
		1	2	3	4	5	
-1	72978	Assembly, Single Auxiliary Pump (See Group 40, Figure 02 for NHA)					Ref
2		• Retainer					1
3		• Assembly, Body					1
4		• Pin, Dowel					2
5		• Bearing, Ball					2
6		• Plate, Wear					1
7		• Gear, Driven					1
8		• Gear, Drive					1
9		• Plate, Thrust					2
10		• Plug, Pipe					1
11		• Assembly, Cover					1
12		• Washer, Flat (attaching parts)					4
13		• Screw, Hex (attaching parts)					4
-14	72978SK	• Kit, Seal					1
15		• • Seal, Shaft					1
16		• • Rubber, Space					1
17		• • Ring, Square Cut					1

DASH (-) ITEM NOT ILLUSTRATED

REVISION:

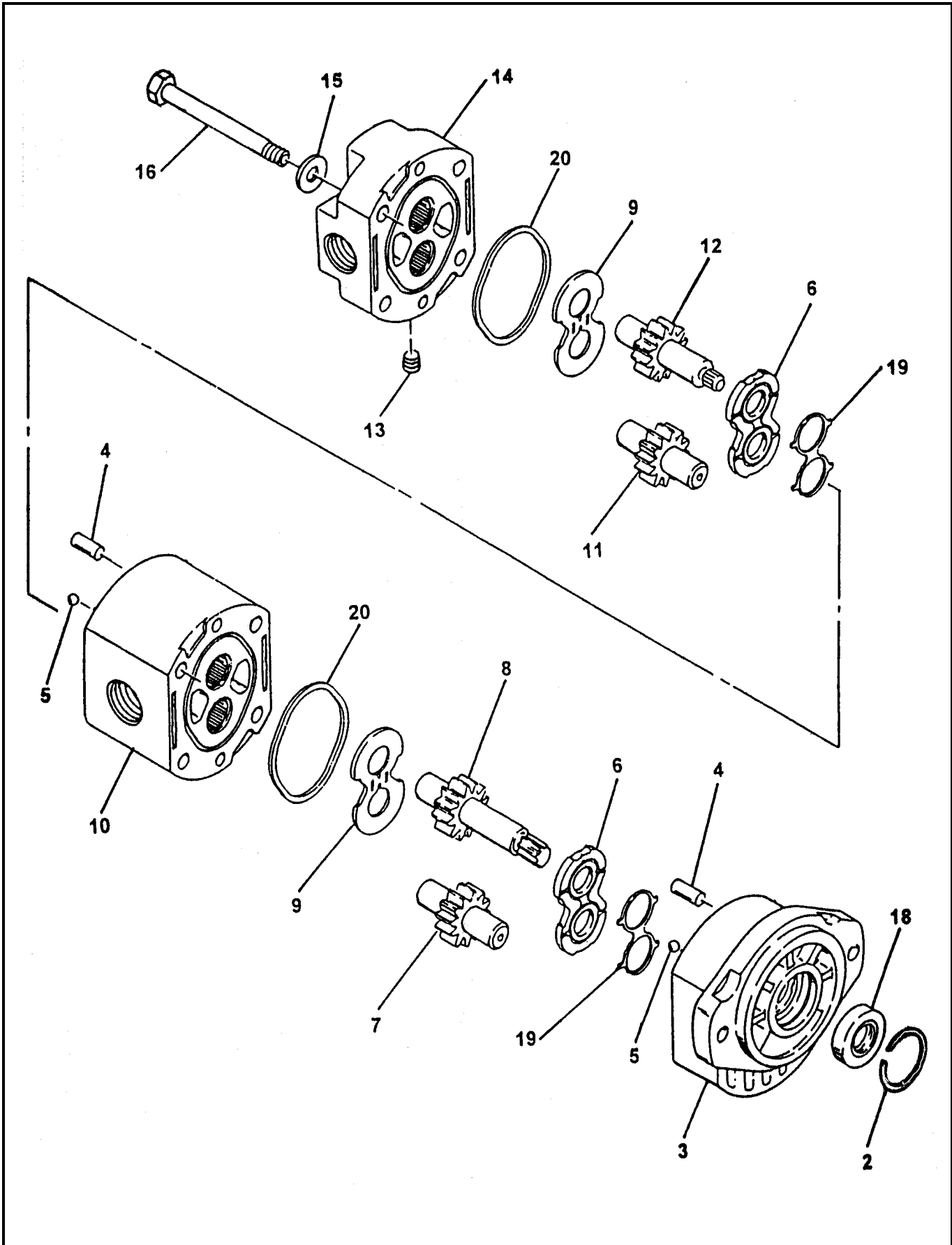

REVISION:



DOUBLE AUXILIARY PUMP ASSEMBLY

01 B70

PARTS

GROUP 40

FIGURE 04

PAGE 02

ITEM NO.	REED'S PARTS NO.	DESCRIPTION	QTY
		1 2 3 4 5	
-1	73156	Assembly Double Auxiliary Pump (See Group 40, Figure 02 for NHA)	Ref
2		• Retainer	1
3		• Assembly, Body	1
4		• Pin, Dowel	4
5		• Bearing, Ball	4
6		• Plate, Wear	2
7		• Gear, Driven	1
8		• Gear, Drive	1
9		• Plate, Thrust	2
10		• Assembly, Middle Body	1
11		• Gear, Rear Driven	1
12		• Cover, Rear Drive	1
13		• Plug, Pipe	1
14		• Assembly, Cover	1
15		• Washer, Flat (attaching parts)	4
16		• Screw, Hex (attaching parts)	4
-17	79598	• Kit, Seal	1
18		• • Seal, Shaft	1
19		• • Rubber, Space	2
20		• • Ring, Square Cut	2

DASH (-) ITEM NOT ILLUSTRATED

REVISION:



MAIN PUMP ASSEMBLY

01 B70

PARTS

GROUP 40

FIGURE 05

PAGE 01

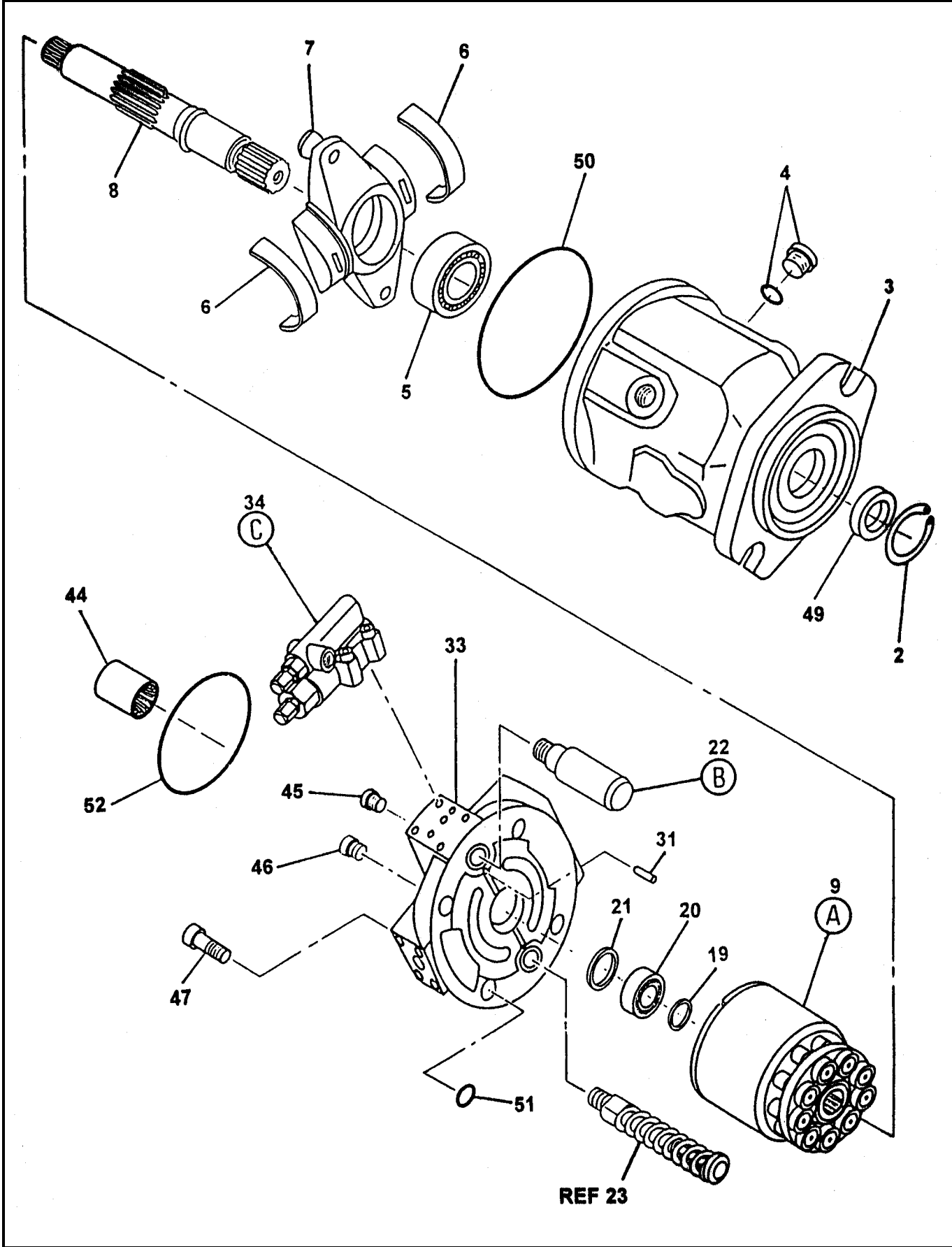

REVISION:



MAIN PUMP ASSEMBLY

01 B70
PARTS
GROUP 40
FIGURE 05
PAGE 02

ITEM NO.	REED'S PARTS NO.	DESCRIPTION	QTY
		1 2 3 4 5	
-1	85124	Assembly, Main Pump (See Group 40, Figure 02 for NHA) (Also See Vendor Section, Figure 02 for REF)	Ref
2		• V-Ring, Seeger	1
3		• Housing, Pump	1
4		• Plug, O-Ring	1
5		• Bearing, Tapered Roller	1
6		• Bearing, Cradle	2
7		• Assembly, Cradle	1
8		• Shaft, Drive	1
9		• Assembly, Rotary	1
23		• Assembly, Piston Control	1
33		• Block	1
34		• Assembly, Control Valve	1
44		• Coupling	1
45		• Plug	1
46		• Plug	1
47		• Screw, Cap	2
-48		• Kit, Seal	1
49		• • Seal, Shaft	1
50		• • O-Ring	1
51		• • O-Ring	1
52		• • O-Ring	1

DASH (-) ITEM NOT ILLUSTRATED

REVISION:

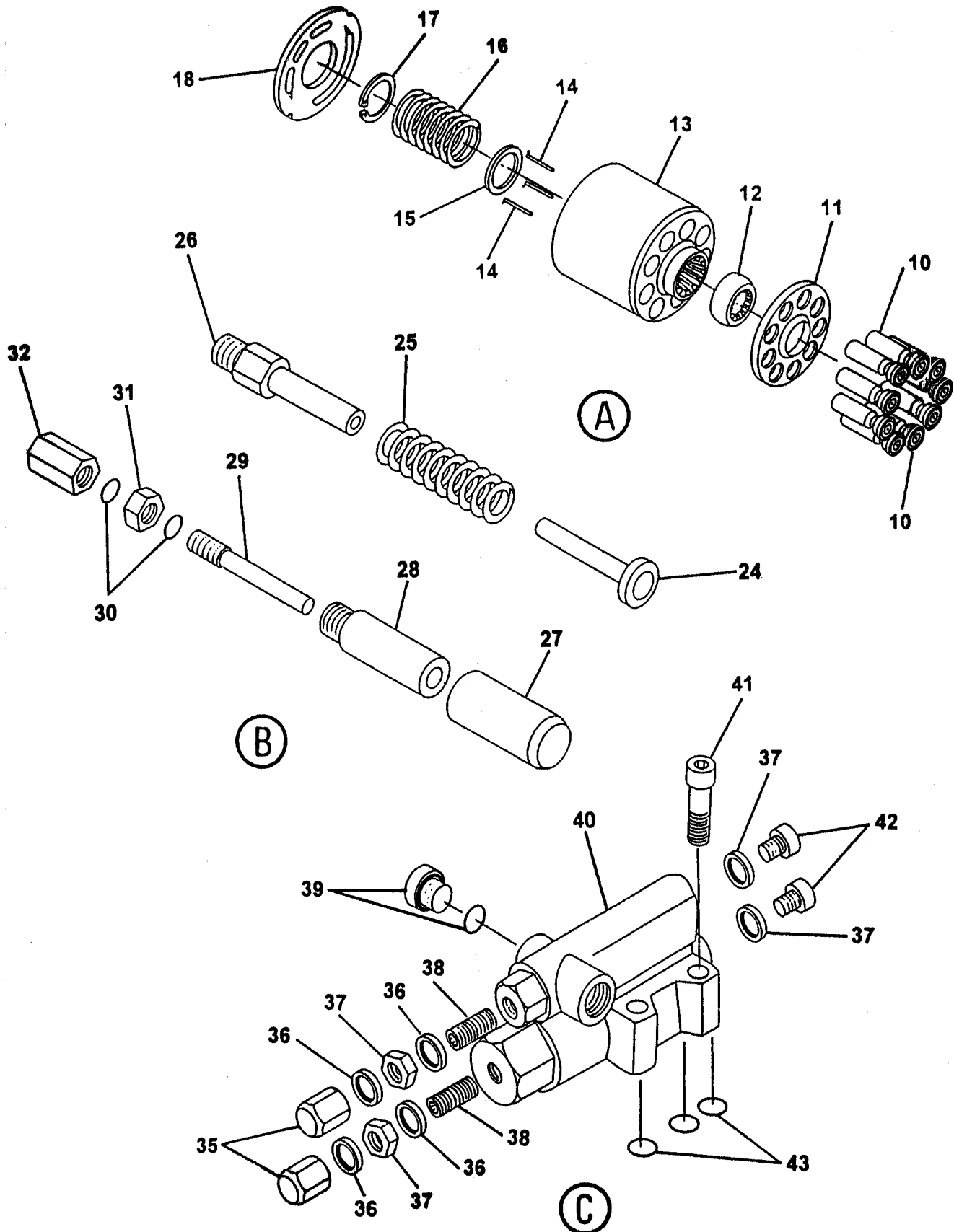

REVISION:



MAIN PUMP ASSEMBLY

01 B70

PARTS

GROUP 40

FIGURE 05

PAGE 04

ITEM NO.	REED'S PARTS NO.	DESCRIPTION					QTY
		1	2	3	4	5	
-9		• Assembly, Rotary					1
10		• • Piston					9
11		• • Plate, Retaining					1
12		• • Ball, Retaining					1
13		• • Barrel					1
14		• • Pin, Pressure					3
15		• • Disc, Retaining Clip					1
16		• • Spring					1
17		• • Ring, Retaining					1
18		• • Plate, Lens					1
-23		• Assembly, Piston Control					1
24		• • Piston, Counter					1
25		• • Spring					1
26		• • Guide, Counter Piston					1
27		• • Piston, Counter					1
28		• • Guide, Counter Piston					1
29		• • Screw, Max Volume Adjustment					1
30		• • O-Ring					2
31		• • Nut, Lock					1
32		• • Nut, Acorn					1
-34		• Assembly, Control Valve					1
35		• • Nut, Acorn					2
36		• • O-Ring					3
37		• • Nut, Jam					2
38		• • Screw, Adjusting					2
39		• • Plug, O-Ring					1
40		• • Body, Control Valve					1
41		• • Screw, Cap (attaching parts)					4
42		• • Plug					2
43		• • O-Ring					3

DASH (-) ITEM NOT ILLUSTRATED

REVISION:



BATTERY MOUNT ASSEMBLY

01 B70

PARTS

GROUP 40

FIGURE 06

PAGE 01

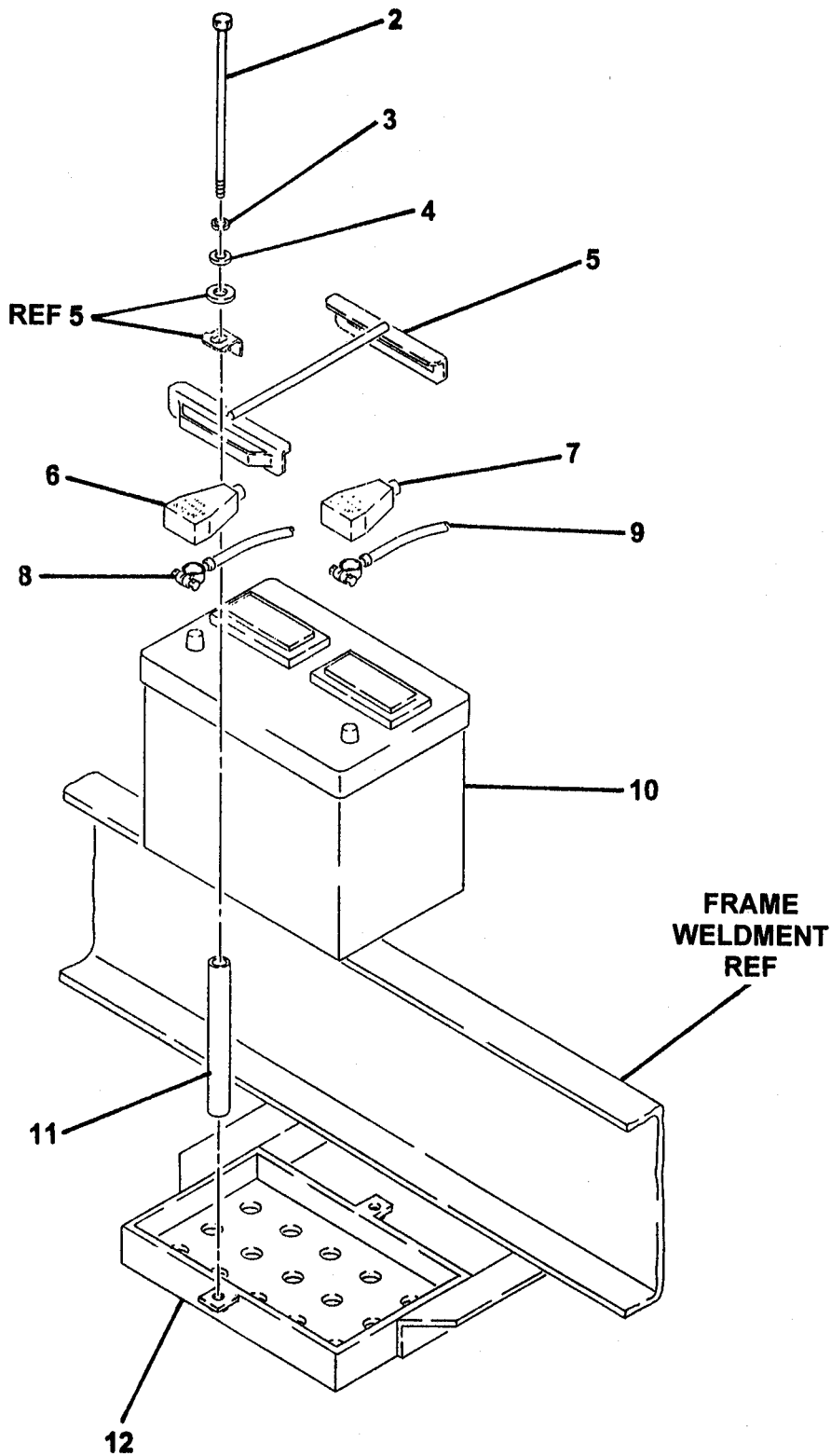

REVISION:



BATTERY MOUNT ASSEMBLY

01 B70

PARTS

GROUP 40

FIGURE 06

PAGE 02

ITEM NO.	REED'S PARTS NO.	DESCRIPTION	QTY
		1 2 3 4 5	
-1	40-06	Assembly, Battery Mounting (See Group 40, Figure 01 for NHA)	Ref
2		• Bolt, Hex	2
3		• Washer, Lock	2
4		• Washer Flat	2
5	72945	• Holder, Battery Down	1
6	77720	• Insulator, Negative Battery (Black)	1
7	77719	• Insulator, Positive Battery (Red)	1
8	75116	• Cable, Negative Battery (Black)	1
9	72016	• Cable, 24 Inch Long Positive Battery (Red)	1
10	77075	• Battery, 12 VDC	1
11	73753	• Spacer, Battery Mounting	2
12	72954	• Weldment, Battery Box	1
-13	72014	• Cable, 36 Inch Long Battery Top	1
-14	85348	• Connector, SPNO 12 VDC	1

DASH (-) ITEM NOT ILLUSTRATED

REVISION:

THIS PAGE INTENTIONALLY LEFT BLANK.

REED TRAILER MOUNTED CONCRETE PUMP 01 MODEL B70 ILLUSTRATED PARTS MANUAL GROUP 50 CONTROLS INSTALLATION CONTAINS THE FOLLOWING FIGURES:

- FIGURE 00** TABLE OF CONTENTS
- FIGURE 01** CONTROLS INSTALLATION
- FIGURE 02** CONTROL BOX ASSEMBLY
- FIGURE 03** 50 FEET CABLE REMOTE CONTROL ASSEMBLY
- FIGURE 04** 100 FEET CABLE REMOTE CONTROL ASSEMBLY
- FIGURE 05** RADIO REMOTE CONTROL ASSEMBLY

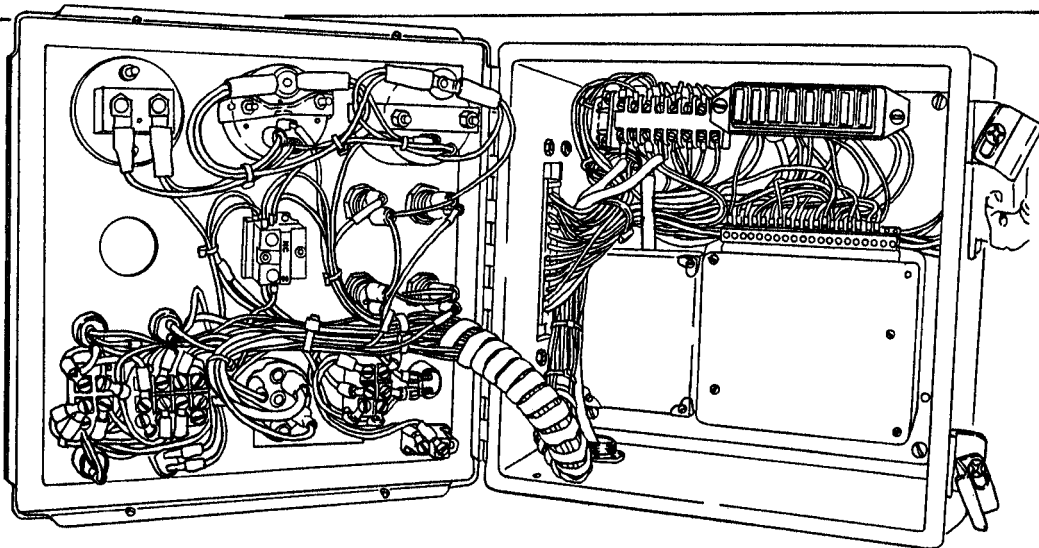
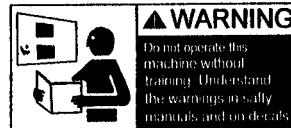



CONTROL INSTALLATION

01 B70
PARTS
GROUP 50
FIGURE 01
PAGE 01

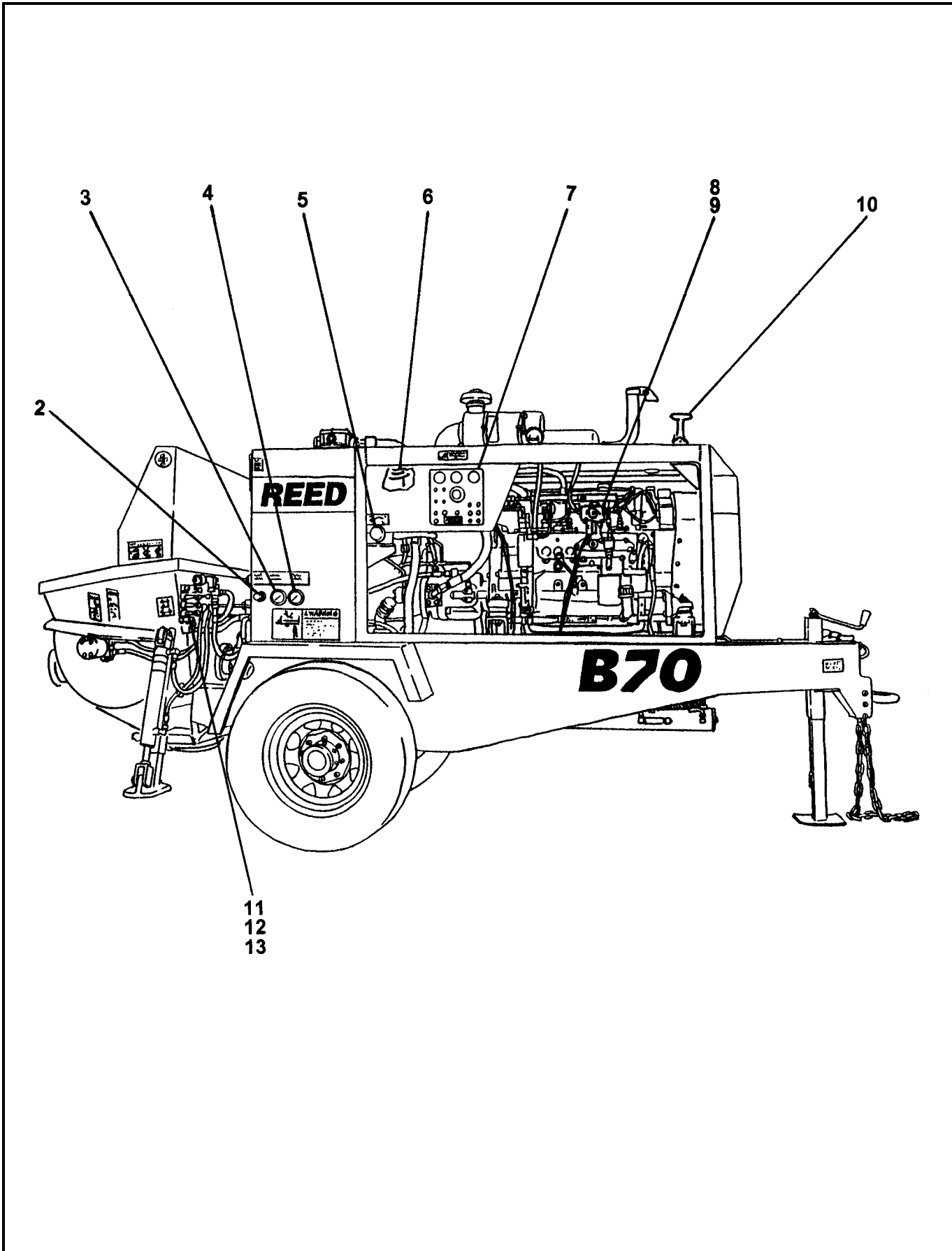

REVISION:



CONTROL INSTALLATION

01 B70
PARTS
GROUP 50
FIGURE 01
PAGE 02

ITEM NO.	REED'S PARTS NO.	DESCRIPTION	QTY
		1 2 3 4 5	
-1	50-01	Installation, Control (See Group 10, Figure 01 for NHA)	Ref
2	78201	• Cable, Throttle Control (See Group 40, Figure 01 for REF)	1
3	70366	• Gauge, 3,000 PSI Hydraulic (See Group 30, Figure 02 for REF)	1
4	74562	• Gauge, 6,000 PSI Hydraulic (See Group 30, Figure 02 for REF)	1
5	85697	• Cartridge, Flow Control Valve (See Group 30, Figure 07 for REF)	1
6	800347	• Horn, 12 V	1
7	85358	• Assembly, Control Box (See Group 50, Figure 02 for DET)	1
8	85359	• Assembly, 50 Feet Cable Remote Control (See Group 50, Figure 03 for DET)	1
9	85359A	• Assembly, 100 Feet Cable Remote Control (See Group 50, Figure 04 for DET)	1
10	85818	• Assembly, Radio Remote Control (Optional Item) (See Group 50, Figure 05 for DET)	1
11	20-05	• Assembly, 3 Spool Control Valve (Optional Item) (See Group 20, Figure 05 for REF)	1
12	80-16	• Assembly, 1 Spool Control Valve (Optional Item) (See Group 80, Figure 16 for REF)	1
13	80-18	• Assembly, 2 Spool Control Valve (Optional Item) (See Group 80, Figure 18 for REF)	1

DASH (-) ITEM NOT ILLUSTRATED



CONTROL BOX ASSEMBLY

01 B70
PARTS
GROUP 50
FIGURE 02
PAGE 01

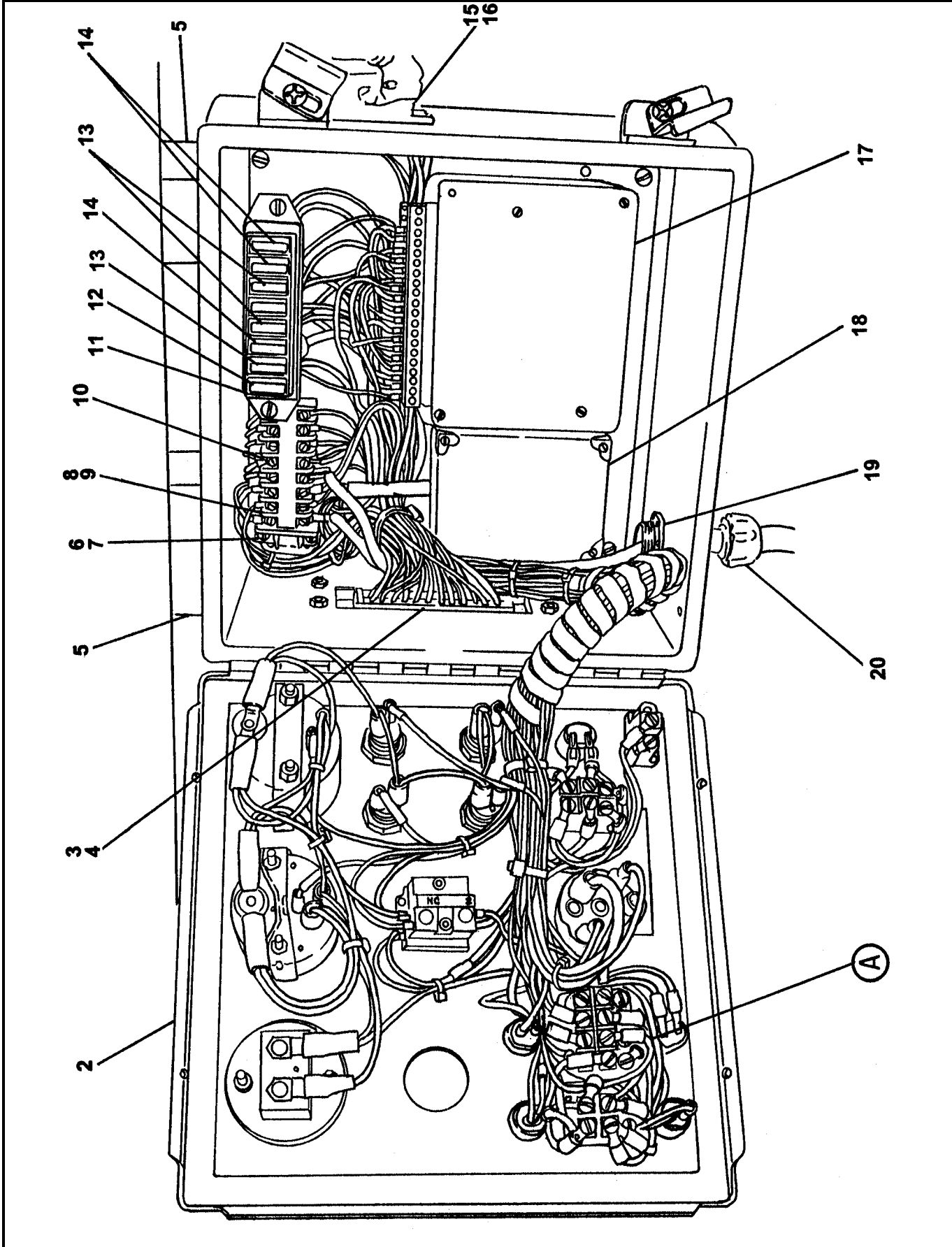

REVISION:



CONTROL BOX ASSEMBLY

01 B70
PARTS
GROUP 50
FIGURE 02
PAGE 02

ITEM NO.	REED'S PARTS NO.	DESCRIPTION	QTY
		1 2 3 4 5	
-1	85358	Assembly, Control Box (See Group 50, Figure 01 for NHA)	Ref
2	85400	• Box, Control	1
3	78696	• Insert, Connector	1
4	78697	• Base, Connector	1
5	73748	• Bumper	4
6	75654	• End, Barrier	1
7	72821	• Rail, 0.333 Feet Barrier	1
8	72820	• Terminal	8
9	72824	• Jumper	2
10	85354	• Block, Fuse	1
11	85419	• Stand Off	1
12	800447	• Fuse, 25	1
13	800449	• Fuse, 10	4
14	90392	• Fuse, 5	3
15	79963	• Insert, Connector	1
16	79965	• Base, Connector	1
17	85596	• Box, Black	1
18	85334	• Box, Pump Black	1
19	10528	• Nut	1
20	10523	• Relief, Strain	1

DASH (-) ITEM NOT ILLUSTRATED



CONTROL BOX ASSEMBLY

01 B70
PARTS
GROUP 50
FIGURE 02
PAGE 03

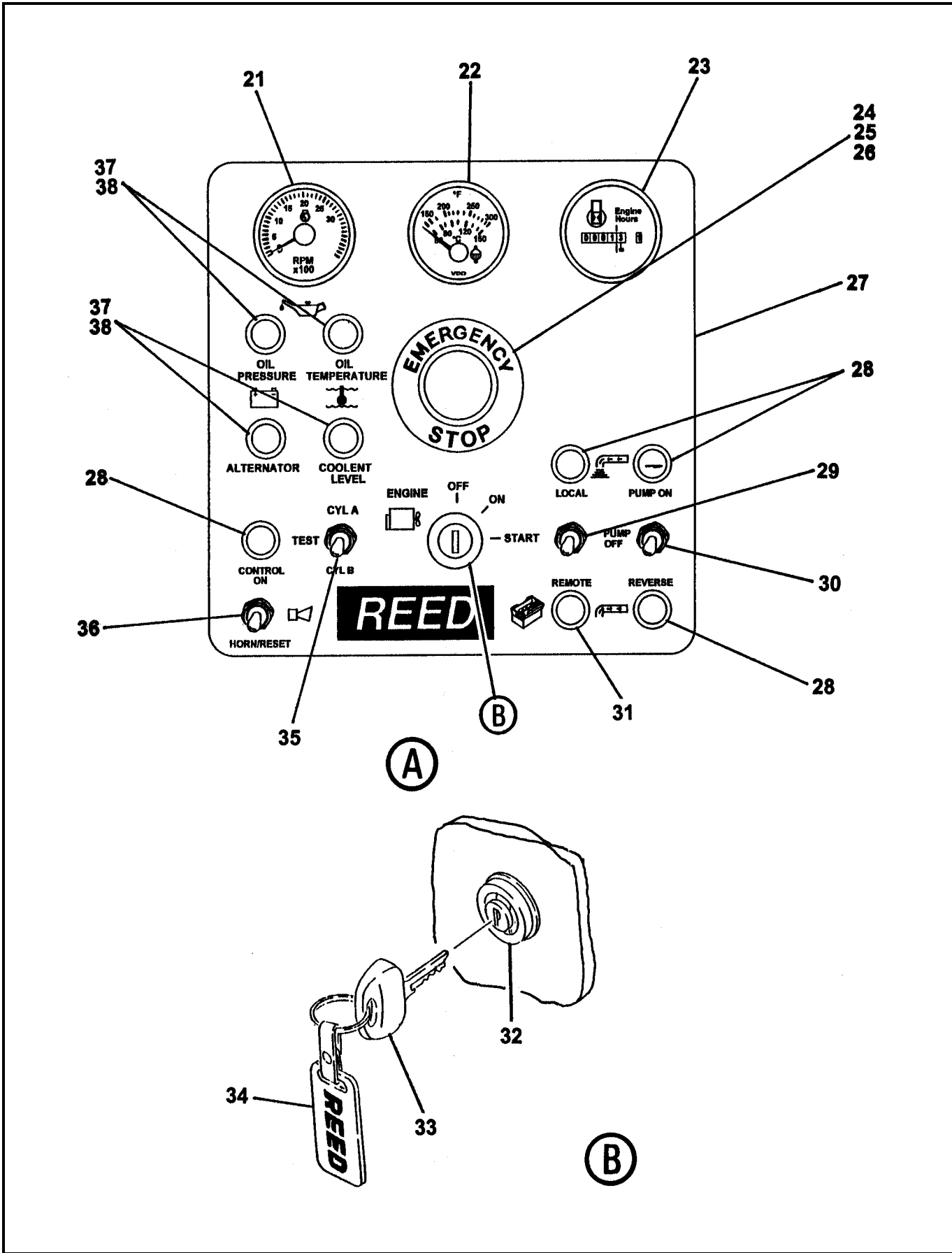

REVISION:



CONTROL BOX ASSEMBLY

01 B70

PARTS

GROUP 50

FIGURE 02

PAGE 04

ITEM NO.	REED'S PARTS NO.	DESCRIPTION					QTY
		1	2	3	4	5	
21	78687	• Tachometer					1
22	78203	• Gauge, Water Temperature					1
23	74240	• Meter, Engine Hour					1
24	85342	• Operator, Emergency Stop					1
25	85343	• Block, Contact					1
26	85344	• Bulb, Emergency Stop					1
27	85332	• Decal, Control Box					1
28	85355	• Pilot, Light					4
29	78563	• Switch, Local / Remote					1
30	72003	• Switch, Pump On / Reverse					1
31	85356	• Pilot, Light					1
32	71154	• Switch, Ignition					1
33	71155	• • Key (Pair)					1
34	72862	• Gauge, Proximity Switch					1
35	85346	• Switch, CYL A / CYL B					1
36	85347	• Switch, Horn / Reset					1
37	73775	• Indicator, Red Light 14 VDC					4
38	72022	• Bulb, Indicator					4
-39	85396	• Assembly, Engine Wiring Harness (See Schematic Section, Page 11 for REF)					1
-40	86533	• Assembly, Trailer Wiring Harness (See Schematic Section, Page 12 for REF)					1

DASH (-) ITEM NOT ILLUSTRATED

REVISION:



50 FEET CABLE
REMOTE CONTROL ASSEMBLY

01 B70
PARTS
GROUP 50
FIGURE 03
PAGE 01

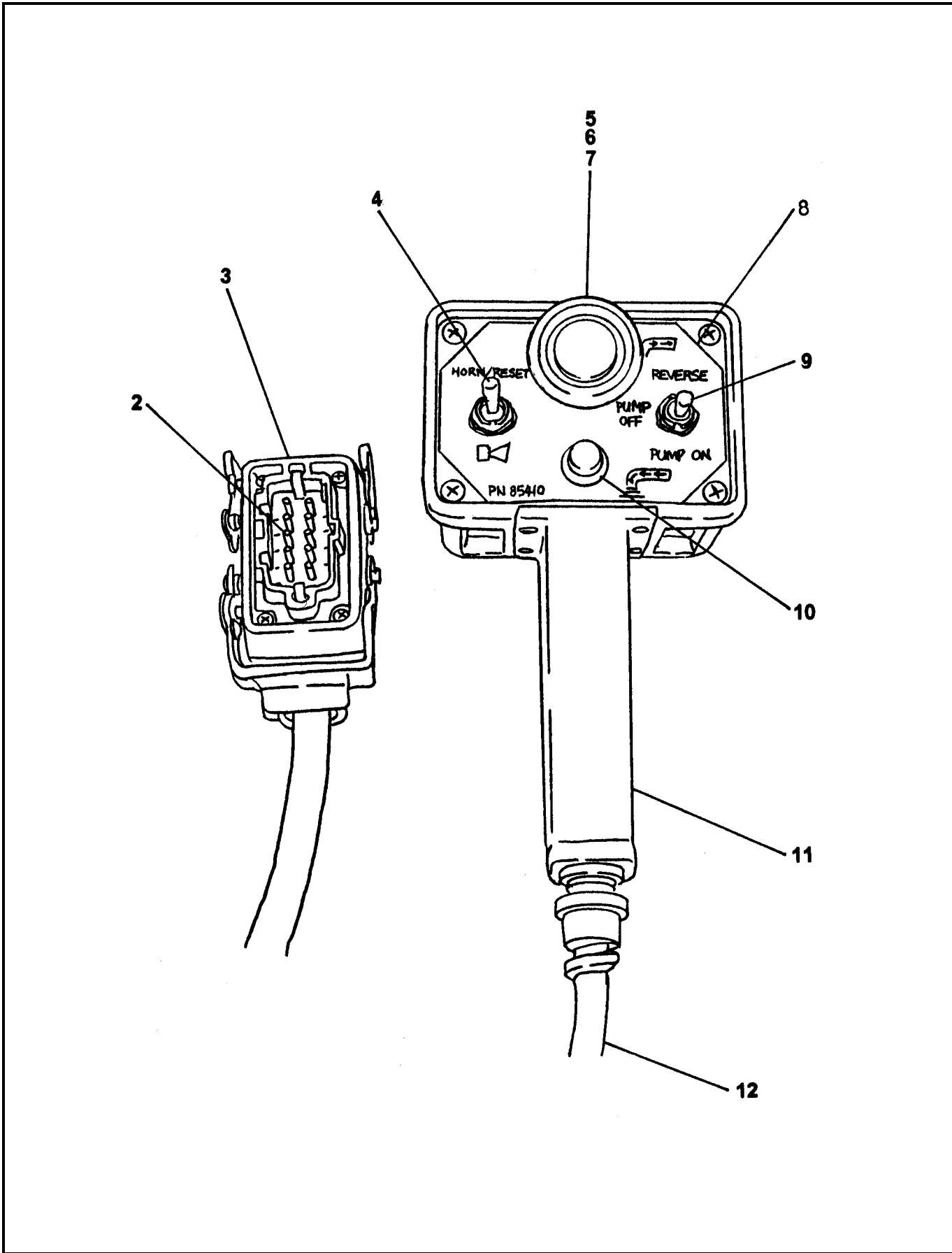

REVISION:



**50 FEET CABLE
REMOTE CONTROL ASSEMBLY**

01 B70

PARTS

GROUP 50

FIGURE 03

PAGE 02

ITEM NO.	REED'S PARTS NO.	DESCRIPTION	QTY
		1 2 3 4 5	
-1	85359	Assembly, 50 Feet Cable Remote Control (See Group 50, Figure 01 for NHA)	Ref
2	79964	• Connector, Insert	1
3	79966	• Connector, Hood	1
4	85347	• Switch, Horn / Reset	1
5	85342	• Operator, Emergency Stop	1
6	85343	• Block, Contact	1
7	85344	• Bulb, Emergency Stop	1
8	85410	• Decal, Remote Control Box	1
9	72003	• Switch, Pump On / Reverse	1
10	85355	• Pilot, Light	1
11	71999	• Pistol, Grip	1
12	85620	• Cable, 50 Feet Remote Control	1

DASH (-) ITEM NOT ILLUSTRATED

REVISION:



100 FEET CABLE REMOTE CONTROL ASSEMBLY

01 B70
PARTS
GROUP 50
FIGURE 04
PAGE 01

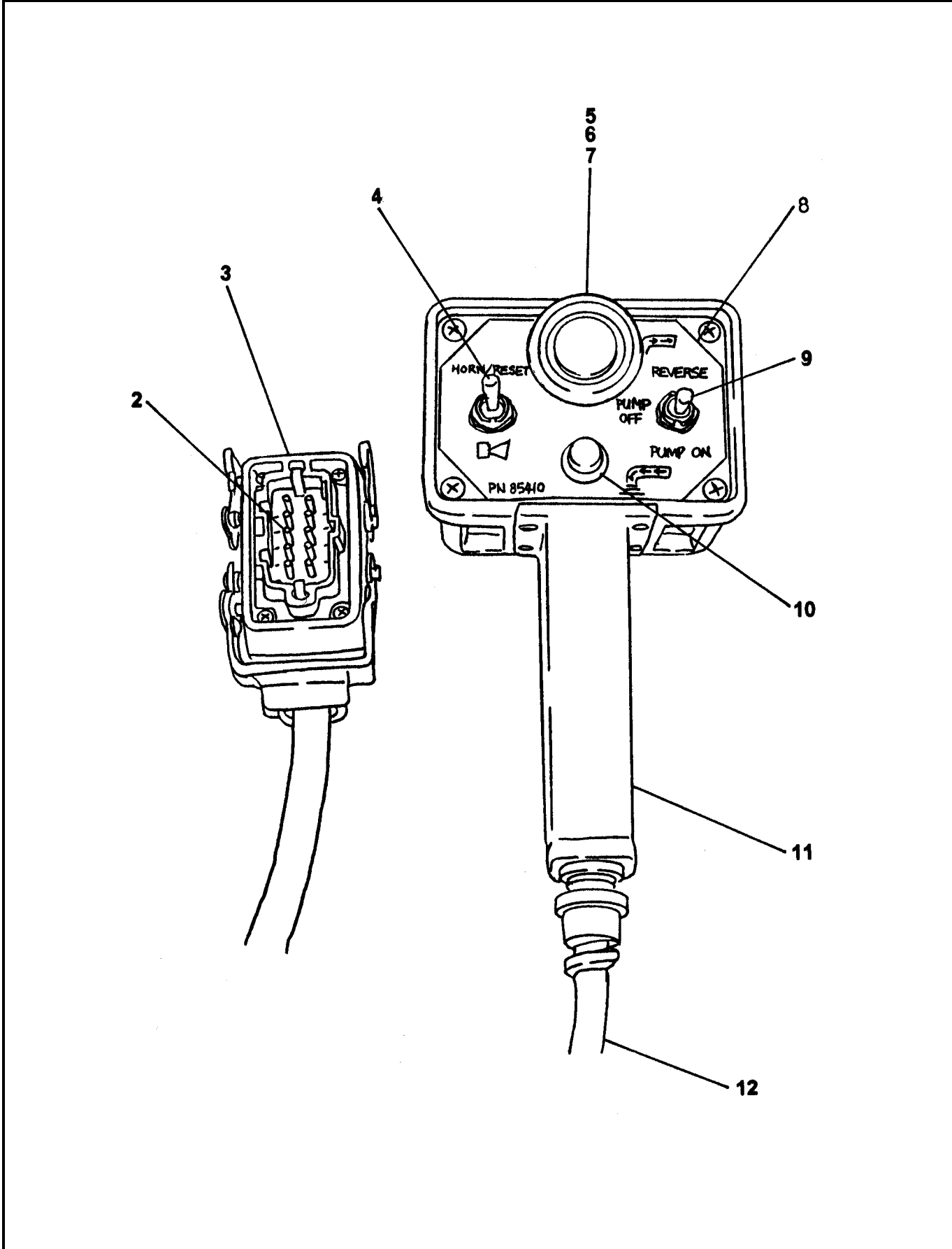

REVISION:



**100 FEET CABLE
REMOTE CONTROL ASSEMBLY**

01 B70
PARTS
GROUP 50
FIGURE 04
PAGE 02

ITEM NO.	REED'S PARTS NO.	DESCRIPTION	QTY
		1 2 3 4 5	
-1	85359A	Assembly, 100 Feet Cable Remote Control (See Group 50, Figure 01 for NHA)	Ref
2	79964	• Connector, Insert	1
3	79966	• Connector, Hood	1
4	85347	• Switch, Horn / Reset	1
5	85342	• Operator, Emergency Stop	1
6	85343	• Block, Contact	1
7	85344	• Bulb, Emergency Stop	1
8	85410	• Decal, Remote Control Box	1
9	72003	• Switch, Pump On / Reverse	1
10	85355	• Pilot, Light	1
11	71999	• Pistol, Grip	1
12	85816	• Cable, 100 Feet Remote Control	1

DASH (-) ITEM NOT ILLUSTRATED



**OPTIONAL RADIO
REMOTE CONTROL ASSEMBLY**

01 B70
PARTS
GROUP 50
FIGURE 05
PAGE 01



REVISION:



**OPTIONAL RADIO
REMOTE CONTROL ASSEMBLY**

01 B70

PARTS

GROUP 50

FIGURE 05

PAGE 02

THIS GROUP 50, FIGURE 05, PARTS NUMBER 85818,
OPTIONAL RADIO REMOTE CONTROL ASSEMBLY,
DETAIL PARTS LIST IS NOT AVAILABLE THIS REVISION.

REVISION:

REED

**TRAILER MOUNTED PUMP 01 MODEL B70
ILLUSTRATED PARTS MANUAL**

01 B70

PARTS

GROUP 50

FIGURE 06

PAGE 01

THIS PAGE INTENTIONALLY LEFT BLANK.

REVISION:

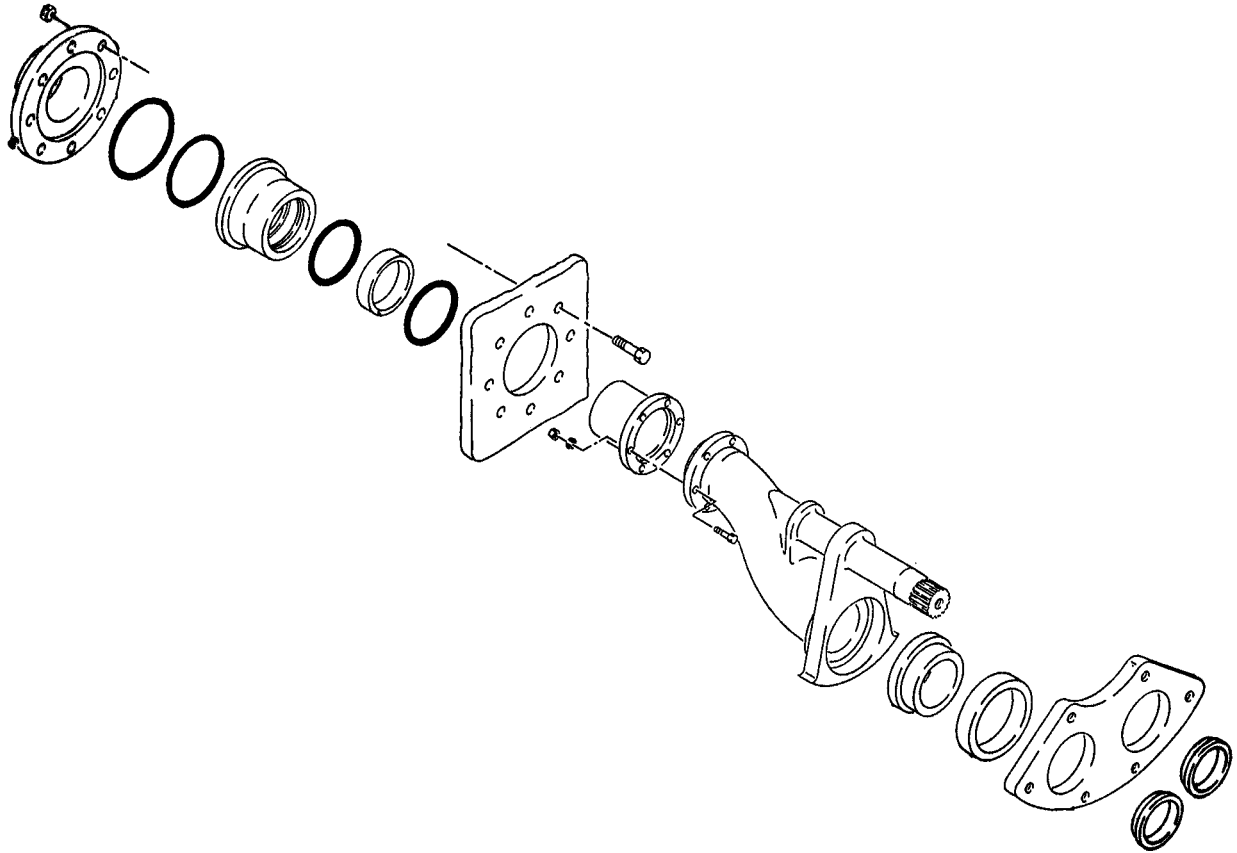

REED TRAILER MOUNTED CONCRETE PUMP 01 MODEL B70 ILLUSTRATED PARTS MANUAL GROUP 60 PUMPING TRAIN INSTALLATION CONTAINS THE FOLLOWING FIGURES:

- | | |
|------------------|--|
| FIGURE 00 | TABLE OF CONTENTS |
| FIGURE 01 | DUAL SHIFT PUMPING TRAIN INSTALLATION |
| FIGURE 02 | DUAL SHIFT SWING VALVE ASSEMBLY |
| FIGURE 03 | DUAL SHIFT SWING RAM CYLINDER SUB-ASSEMBLY |
| FIGURE 04 | MATERIAL CYLINDER ASSEMBLY |
| FIGURE 05 | FLUSHBOX ASSEMBLY |
| FIGURE 06 | HYDRAULIC DRIVE CYLINDER ASSEMBLY |
| FIGURE 07 | HYDRAULIC DRIVE CYLINDER SUB-ASSEMBLY |



DUAL SHIFT PUMPING TRAIN INSTALLATION

01 B70
PARTS
GROUP 60
FIGURE 01
PAGE 01

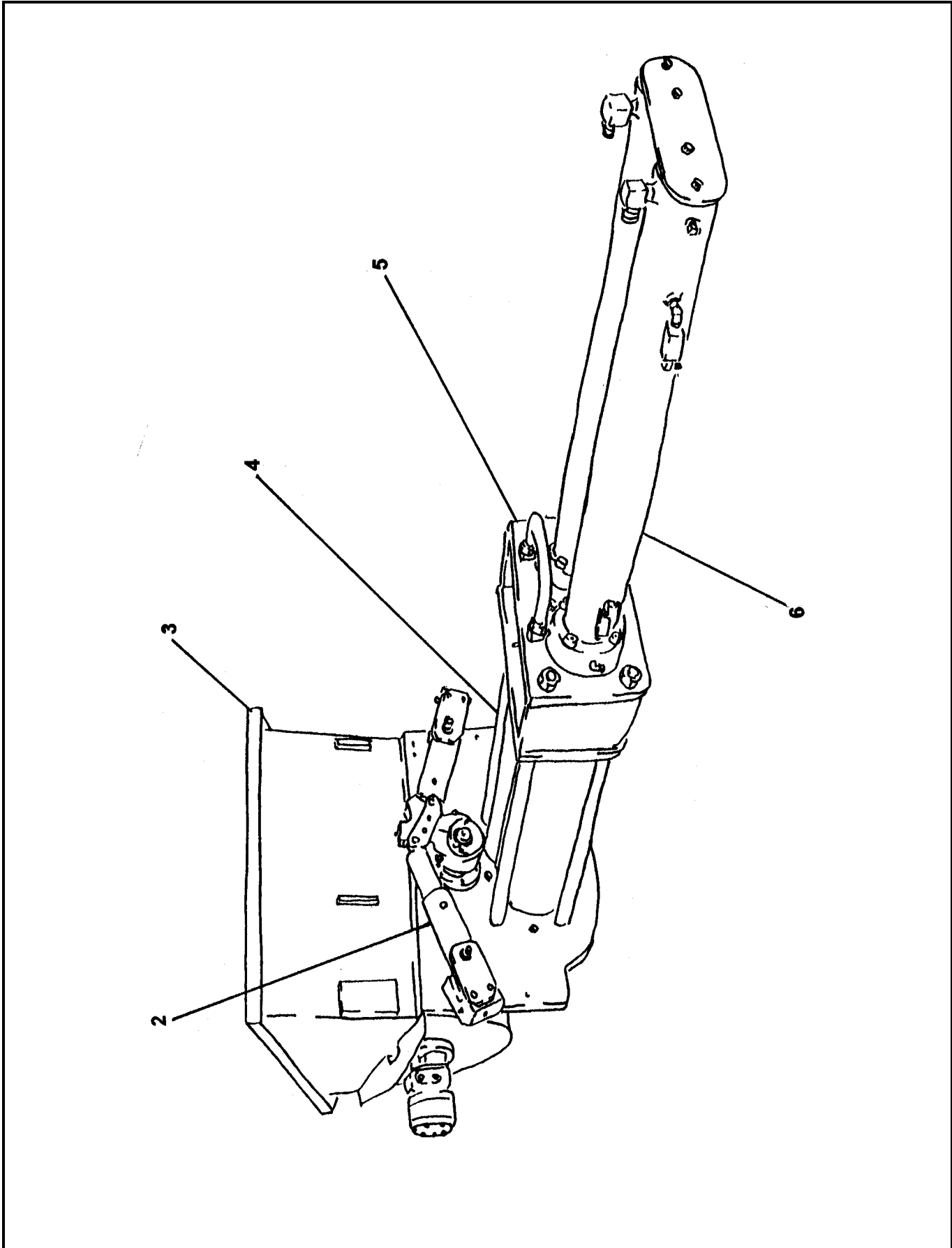

REVISION:



**DUAL SHIFT
PUMPING TRAIN INSTALLATION**

01 B70
PARTS
GROUP 60
FIGURE 01
PAGE 02

ITEM NO.	REED'S PARTS NO.	DESCRIPTION	QTY
		1 2 3 4 5	
-1	60-01	Installation, Dual Shift Pumping Train (See Group 10, Figure 01 for NHA)	Ref
2	60-02	• Assembly, Dual Shift Swing Valve (See Group 60, Figure 02 for DET)	1
3	20-01	• Installation, Harsh Mix Hopper (See Group 20, Figure 01 for REF)	Ref
4	86310	• Assembly, Material Cylinder (See Group 60, Figure 04 for DET)	1
5	60-05	• Assembly, Flushbox (See Group 60, Figure 05 for DET)	1
6	86304	• Assembly, Hydraulic Drive Cylinder (See Group 60, Figure 06 for DET)	1

DASH (-) ITEM NOT ILLUSTRATED



DUAL SHIFT SWING VALVE ASSEMBLY

01 B70
PARTS
GROUP 60
FIGURE 02
PAGE 01

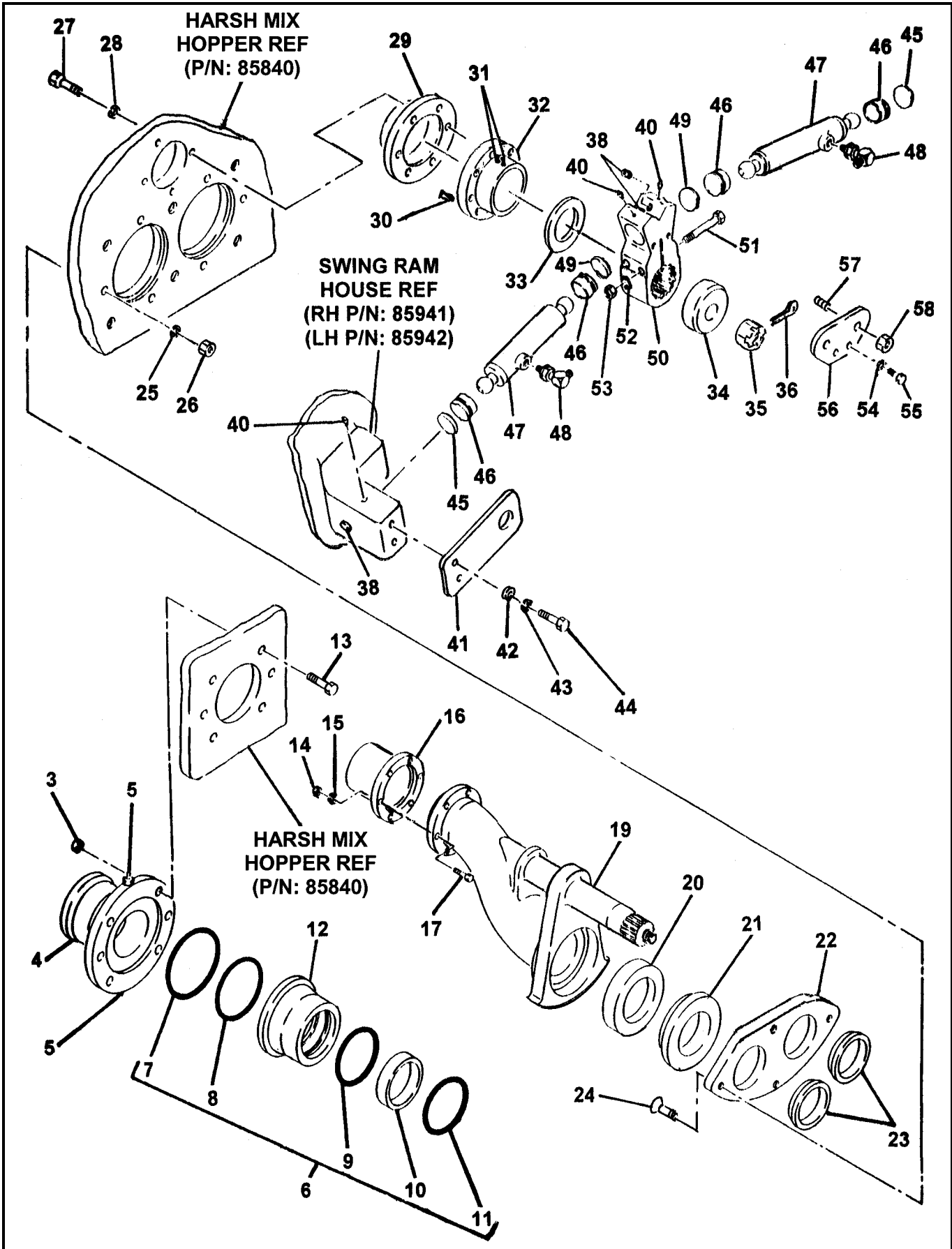

REVISION:



DUAL SHIFT SWING VALVE ASSEMBLY

01 B70
PARTS
GROUP 60
FIGURE 02
PAGE 02

ITEM NO.	REED'S PARTS NO.	DESCRIPTION	QTY
		1 2 3 4 5	
-1	60-02	Assembly, Dual Shift Swing Valve (See Group 60, Figure 01 for NHA)	Ref
-2	86321	• Assembly, Outlet Group	1
3		• • Nut	6
4	72482	• • Outlet, Machine 5"	1
5		• • Fitting, Grease	2
6	79895	• • Kit, Outlet Seal	1
7	77761	• • • O-Ring, Large	1
8	77762	• • • O-Ring, Small	1
9	86504	• • • Seal, Modified Outlet Thick	1
10	77763	• • • Band, Guide	1
11	77765	• • • Seal, Outlet Thick	1
12	72309	• • Housing, Outlet Seal	1
13		• • Bolt, Hex	6
14		• • Nut, Nylock (attaching parts)	6
15		• • Washer, Lock (attaching parts)	6
16	70042	• • Outlet, Chromed	1
17		• • Bolt, Hex (attaching parts)	6
-18	86318	• Assembly, 7 Inch Swing Tube Group	1
19	85973	• • Weldment, 7 Inch Harsh Swing Tube	1
20	85974	• • Seal, 7 Inch Single Lip	1
21	85975	• • Ring, 7 Inch Single Lip Wear	1
22	85970	• • Plate, 7 Inch Wear	1
23	85977	• • Ring, 7 Inch Anti Chip	2
24		• • Bolt, Flat Head	4
25		• • Washer, Lock	4
26		• • Nut, Hex	4
27		• • Bolt, Hex	6
28		• • Washer, Lock	6
29	85962	• • Seal, Flange Bearing	1
30		• • Pin, Dowel	1
31		• • Fitting, Grease 90	2
32	85133	• • Bearing, 3 Inch Spline Flange	1
33	85294	• • Washer, Thrust	1
34	85134	• • Spacer, Swing Tube Nut	1
35	70825	• • Nut, Swing Tube	1
36		• • Pin Cotter	1
-37	86320	• Assembly, Swing Tube Dual Shift Group	1
38		• • Plug, Pipe	4
39	86052	• • Pin, Spring	4
40		• • Fitting, Grease 90	2
41	86441	• • Retainer, Swing Ram	2

DASH (-) ITEM NOT ILLUSTRATED

REVISION:

DUAL SHIFT SWING VALVE ASSEMBLY

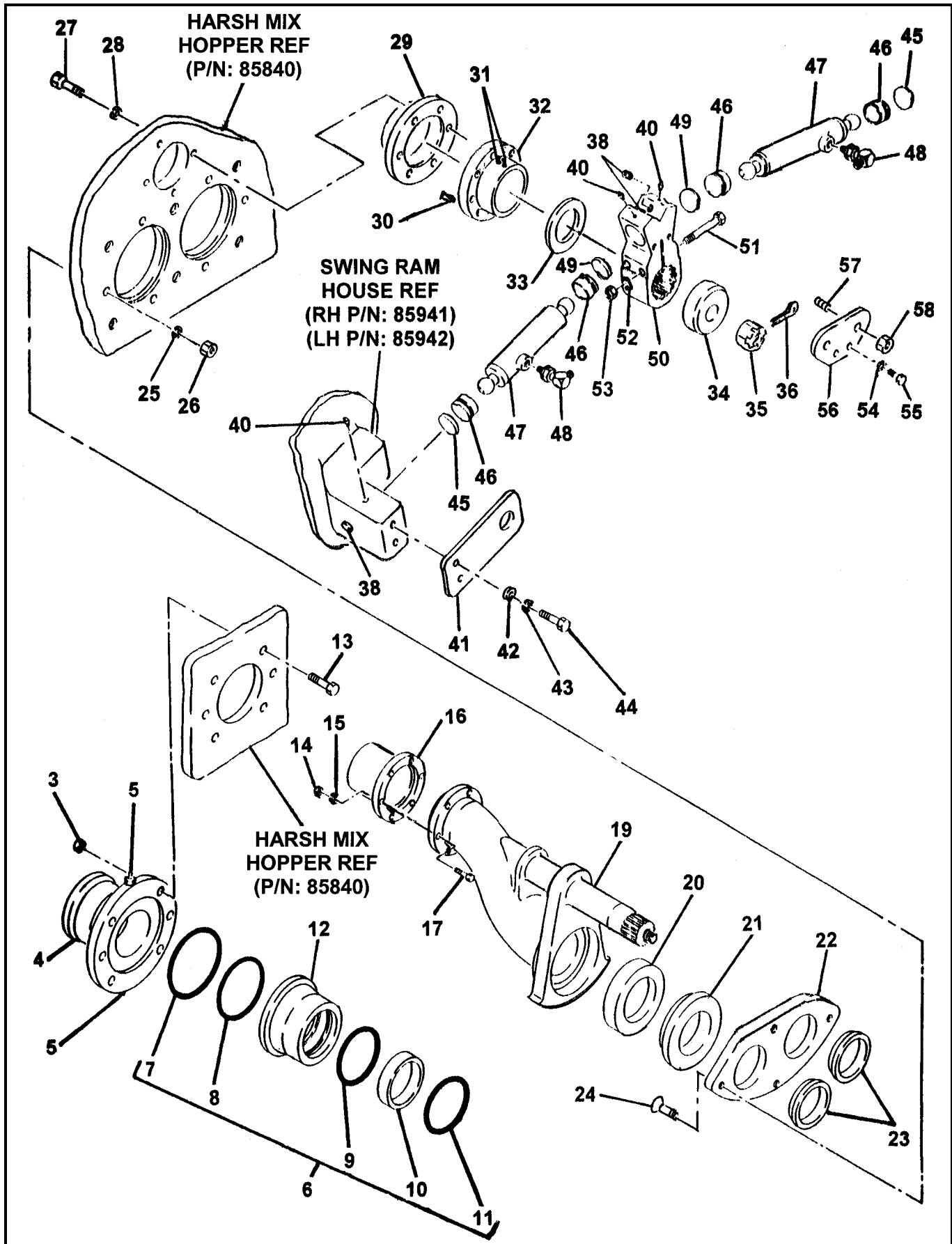

REVISION:

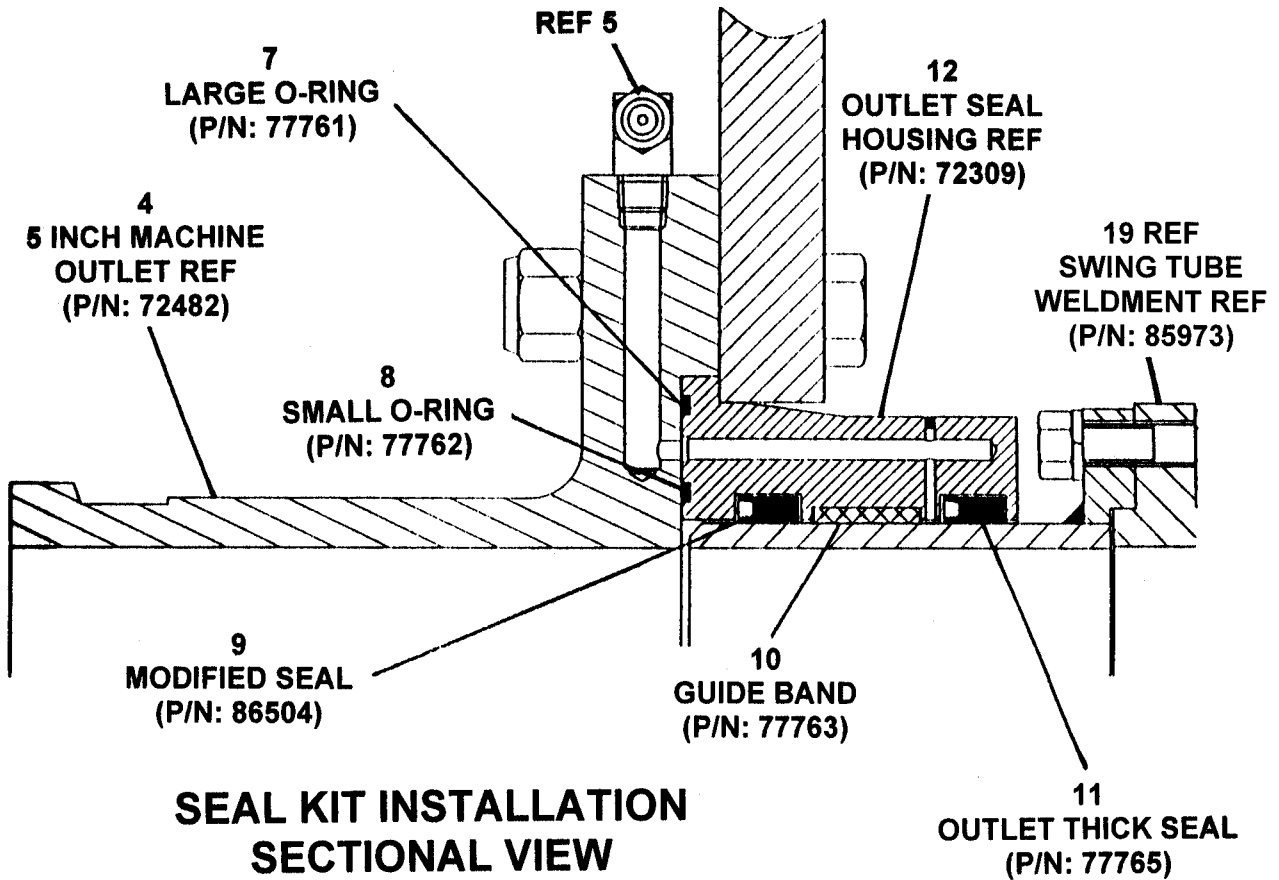

ITEM NO.	REED'S PARTS NO.	DESCRIPTION					QTY
		1	2	3	4	5	
42		••	Washer, Flat (attaching parts)				4
43		••	Washer, Lock (attaching parts)				4
44		••	Bolt, Hex (attaching parts)				4
45	75501	••	Spacer				2
46	76798	••	Socket, Ball				4
47	86220	••	Assembly, Dual Shift Swing Ram Cylinder (See Group 60, Figure 03 for DET)				1
48	75502	••	Fitting, 90				2
49	75501	••	Spacer				2
50	85956	••	Crank, 3 Inch Dual Shift Splined Bell				1
51		••	Bolt, Hex (attaching parts)				2
52		••	Washer, SPL Lock (attaching parts)				2
53		••	Nut, Hex (attaching parts)				2
54		••	Washer, Lock				2
55	86283	••	Bolt, Hex				2
56	86282	••	Retainer, Dual Shift Cylinder				1
57		••	Stud				2
58		••	Nut, Hex				2

DASH (-) ITEM NOT ILLUSTRATED



DUAL SHIFT
SWING RAM CYLINDER ASSEMBLY

01 B70
PARTS
GROUP 60
FIGURE 03
PAGE 01

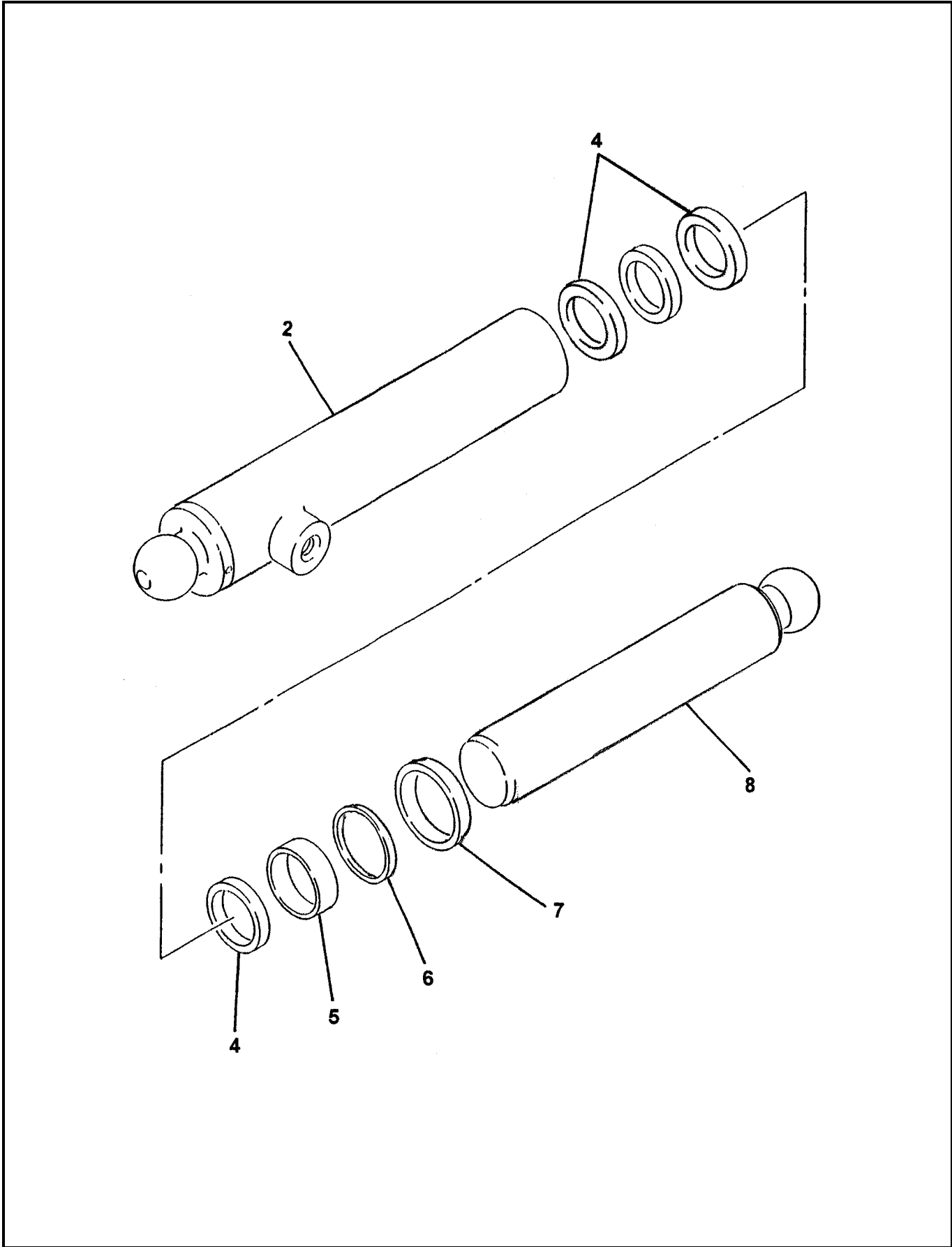

REVISION:



DUAL SHIFT
SWING RAM CYLINDER ASSEMBLY

01 B70

PARTS

GROUP 60

FIGURE 03

PAGE 02

ITEM NO.	REED'S PARTS NO.	DESCRIPTION	QTY
		1 2 3 4 5	
-1	86220	Assembly, Swing Ram Cylinder (See Group 60, Figure 02 for NHA)	Ref
2		• Weldment, Cylinder Case	1
-3	86220-SK	• Kit, Seal	1
4		• • Ring, Wear	1
5		• • U-Cup	1
6		• • Ring, Back Up	4
7		• • Wiper, Rod	1
8		• Weldment, Cylinder Rod	1

DASH (-) ITEM NOT ILLUSTRATED

REVISION:



MATERIAL CYLINDER ASSEMBLY

01 B70

PARTS

GROUP 60

FIGURE 04

PAGE 01

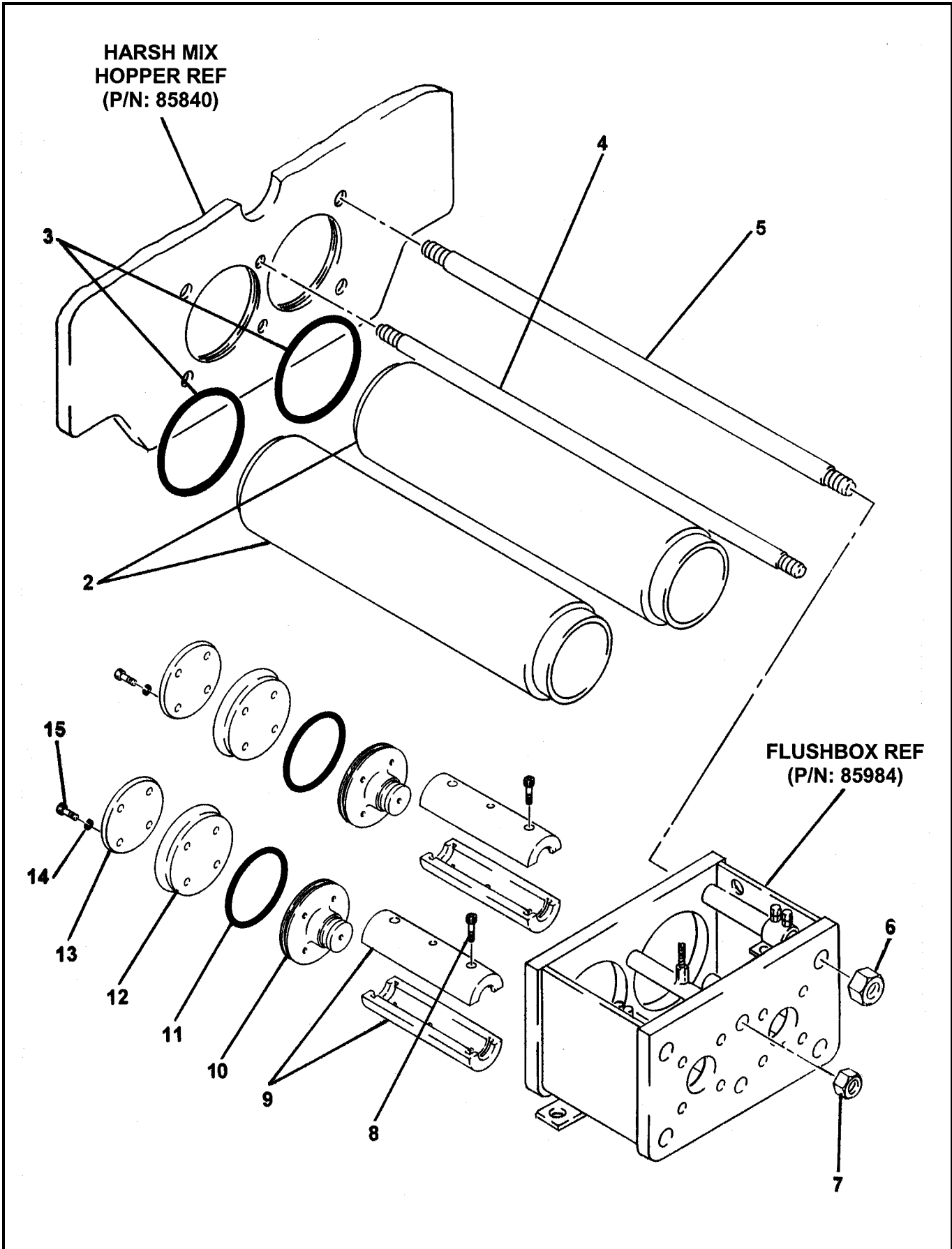

REVISION:



MATERIAL CYLINDER ASSEMBLY

01 B70

PARTS

GROUP 60

FIGURE 04

PAGE 02

ITEM NO.	REED'S PARTS NO.	DESCRIPTION					QTY
		1	2	3	4	5	
-1	86310	Assembly, Material Cylinder (See Group 60, Figure 01 for NHA)					Ref
2	86045	• Cylinder, Material					2
3	86037	• O-Ring, Material Cylinder					2
4	86047	• Rod, Tie					2
5	86046	• Rod, Tie					4
6		• Nut, Hex (attaching Parts)					4
7		• Nut, Hex (attaching Parts)					2
8		• Screw, Cap					4
9	86101	• Coupling, Piston					2
10	77055	• Adapter, 7 Inch Piston					2
11	77056	• Ring, 7 Inch Wear					2
12	70504	• Cup, 7 Inch Piston					2
13	70505	• Plate, 7 Inch Piston					2
14		• Washer, Star (attaching Parts)					8
15		• Bolt, Hex (attaching Parts)					8

DASH (-) ITEM NOT ILLUSTRATED

REVISION:



FLUSH BOX ASSEMBLY

01 B70

PARTS

GROUP 60

FIGURE 05

PAGE 01

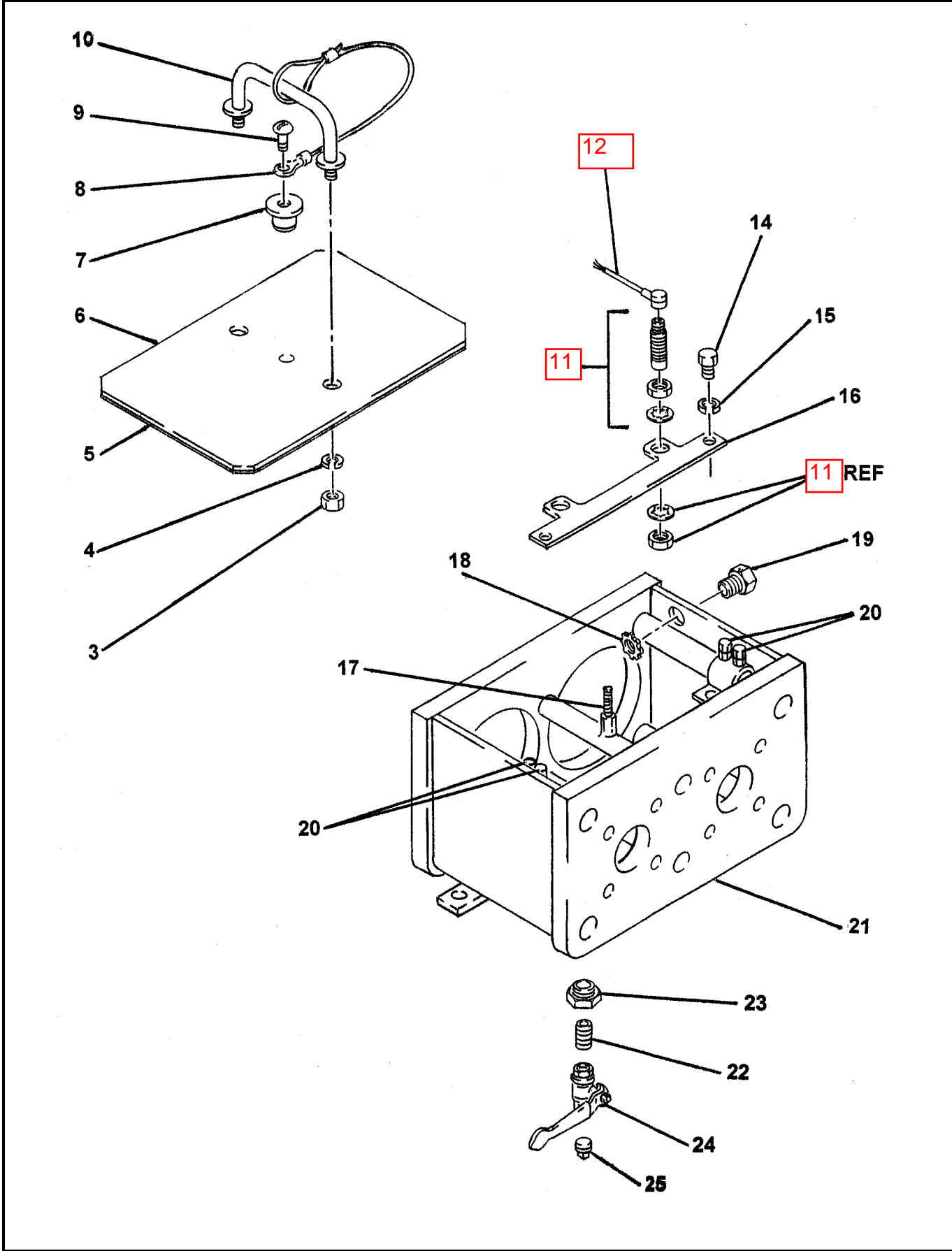

REVISION:



FLUSH BOX ASSEMBLY

01 B70

PARTS

GROUP 60

FIGURE 05

PAGE 02

ITEM NO.	REED'S PARTS NO.	DESCRIPTION	QTY
		1 2 3 4 5	
-1	60-05	Assembly, Flushbox (See Group 60, Figure 01 for NHA)	Ref
-2	86106	• Assembly, Flush Box Cover	1
3		• • Nut, Hex	2
4		• • Washer, Lock	2
5	13257	• • Weatherstrip, Rubber	A/R
6	86010	• • Weldment, Flush Box Cover	1
7	86105	• • Knob	1
8	800418	• • Lanyard	1
9		• • Screw, Round Head	1
10	79056	• • Handle, Splash Guard	1
11	77998	• Sensor, Proximity Switch	2
12	77990	• Cable, Proximity Switch	2
-13	86308	• Assembly, 7 Inch Flush Box Group	1
14		• • Bolt, Hex	2
15		• • Washer, Lock	2
16	86006	• • Bracket, Proximity Switch	1
17	86665	• • Stud	1
18	10528	• • Nut	1
19	73783	• • Conduit, Fitting	1
20		• • Bolt, Hex	4
21	85984	• • Weldment, 7 Inch Flush Box	1
22	10224	• Bushing, Hex	1
23	10355	• Nipple	1
24	56413	• Valve, Ball	1
25	74944	• Plug	1

DASH (-) ITEM NOT ILLUSTRATED

REVISION:



HYDRAULIC DRIVE CYLINDER ASSEMBLY

01 B70

PARTS

GROUP 60

FIGURE 06

PAGE 01

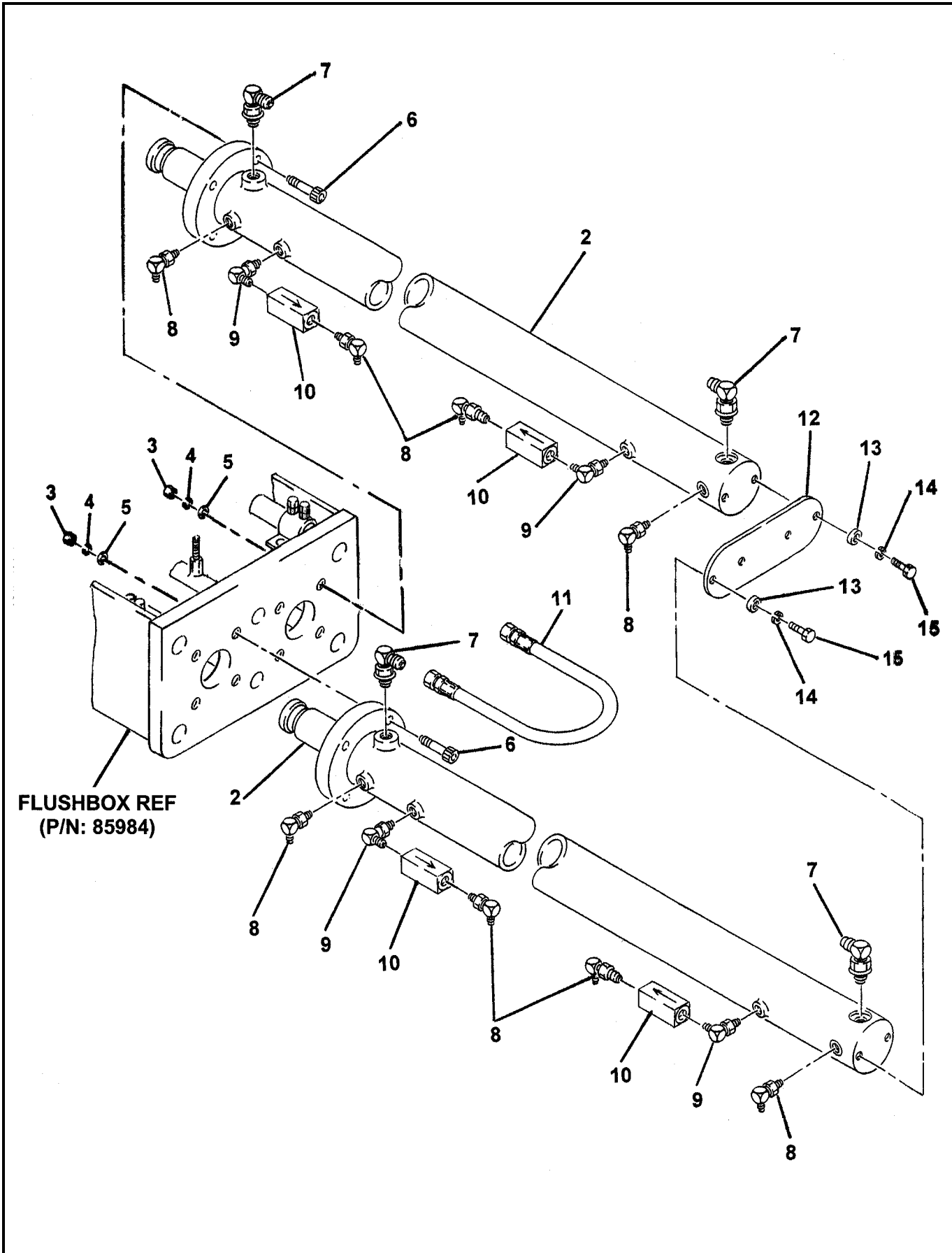

REVISION:



HYDRAULIC DRIVE CYLINDER ASSEMBLY

01 B70

PARTS

GROUP 60

FIGURE 06

PAGE 02

ITEM NO.	REED'S PARTS NO.	DESCRIPTION	QTY
		1 2 3 4 5	
-1	86304	Assembly, Hydraulic Drive Cylinder (See Group 60, Figure 01 for NHA)	Ref
2	86223	• Assembly, Drive Cylinder (See Group 60, Figure 07 for DET)	1
3		• Nut, Hex (attaching parts)	8
4		• Washer, Lock (attaching parts)	8
5	77396	• Washer, Thread (attaching parts)	8
6		• Bolt (attaching parts)	8
7		• Fitting, 90	4
8		• Fitting, 90	8
9		• Fitting, 90	4
10	78961	• Valve, Check	4
11	85427	• Assembly, Tube	1
12	86544	• Plate, End	1
13		• Washer, Flat (attaching parts)	4
14		• Washer, Lock (attaching parts)	4
15		• Bolt, Hex (attaching parts)	4

DASH (-) ITEM NOT ILLUSTRATED

REVISION:



DRIVE CYLINDER ASSEMBLY

01 B70

PARTS

GROUP 60

FIGURE 07

PAGE 01

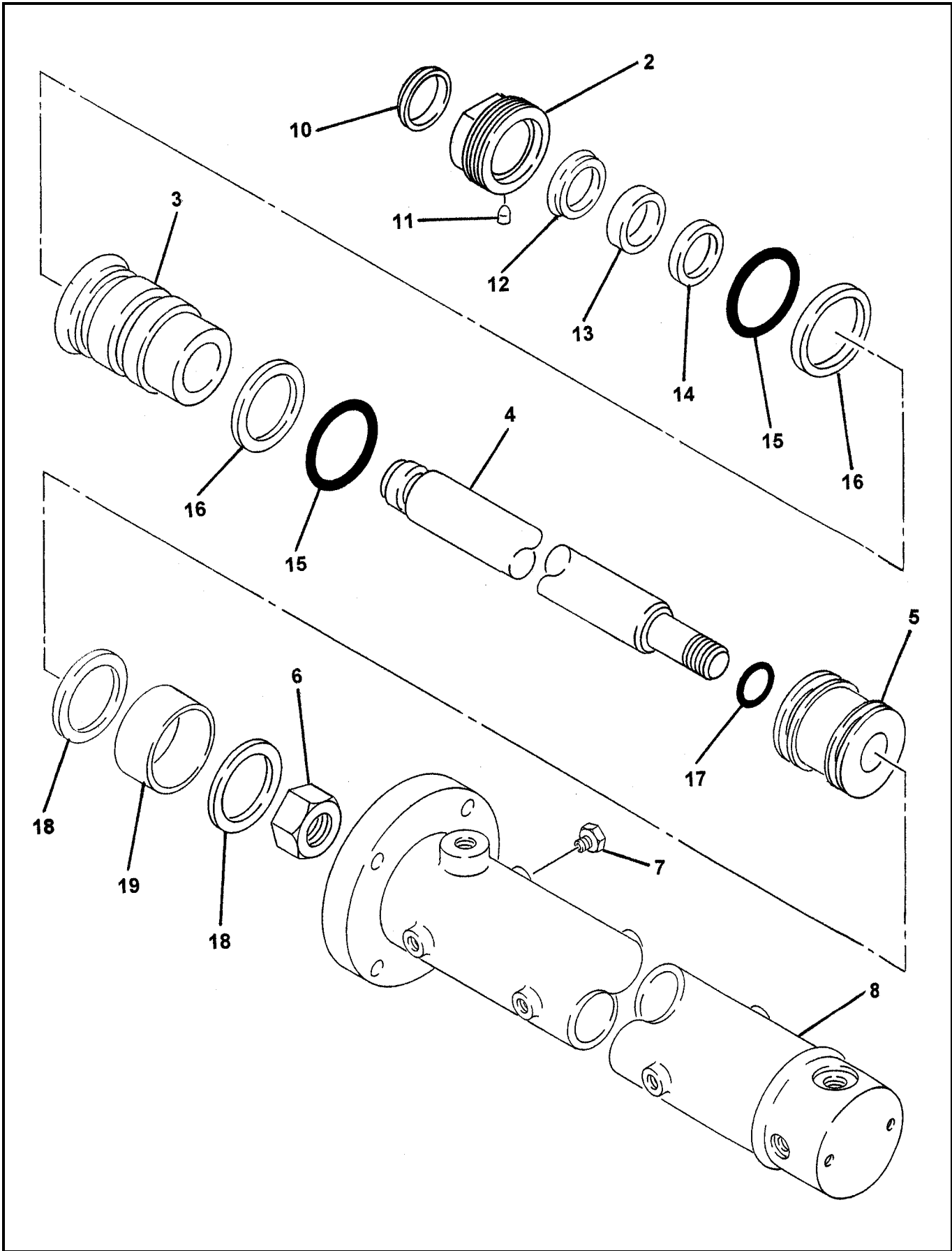

REVISION:



DRIVE CYLINDER ASSEMBLY

01 B70

PARTS

GROUP 60

FIGURE 07

PAGE 02

ITEM NO.	REED'S PARTS NO.	DESCRIPTION					QTY
		1	2	3	4	5	
-1	86223	Assembly, Drive Cylinder (See Group 60, Figure 06 for NHA)					Ref
2		• Ring, Threaded					1
3		• Gland, Head					1
4		• Rod, Cylinder					1
5		• Piston					1
6		• Nut, Piston					1
7		• Plug					4
8		• Weldment, Cylinder Case					1
-9	86223-SK	• Kit, Seal					1
10		• • Wiper, Rod					1
11		• • Plug, Nylon					1
12		• • Ring, Back Up					1
13		• • U-Cup					1
14		• • Seal, Buffer					1
15		• • O-Ring					2
16		• • Ring, Back Up					2
17		• • O-Ring					1
18		• • Seal, Piston					2
19		• • Ring, Wear					1

DASH (-) ITEM NOT ILLUSTRATED

REVISION:



**TRAILER MOUNTED PUMP 01 MODEL B70
ILLUSTRATED PARTS MANUAL**

01 B70

PARTS

GROUP 60

FIGURE 08

PAGE 01



REED TRAILER MOUNTED CONCRETE PUMP 01 MODEL B70 ILLUSTRATED PARTS MANUAL GROUP 70 FRAME INSTALLATION CONTAINS THE FOLLOWING FIGURES:

- FIGURE 00** TABLE OF CONTENTS
- FIGURE 01** FRAME INSTALLATION
- FIGURE 02** HUB AND BRAKE ASSEMBLY
- FIGURE 03** NON-OPERATOR SIDE ELECTRIC BRAKE ASSEMBLY
- FIGURE 04** OPERATOR SIDE ELECTRIC BRAKE ASSEMBLY

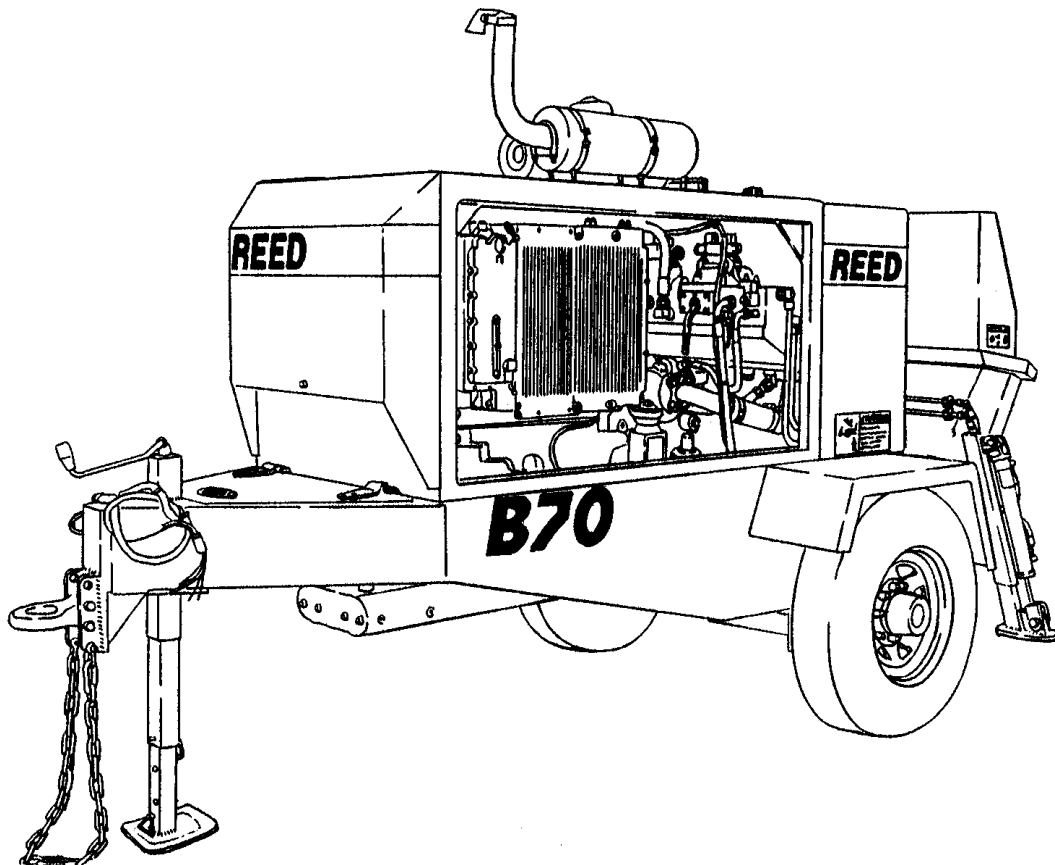



FRAME INSTALLATION

01 B70
PARTS
GROUP 70
FIGURE 01
PAGE 01

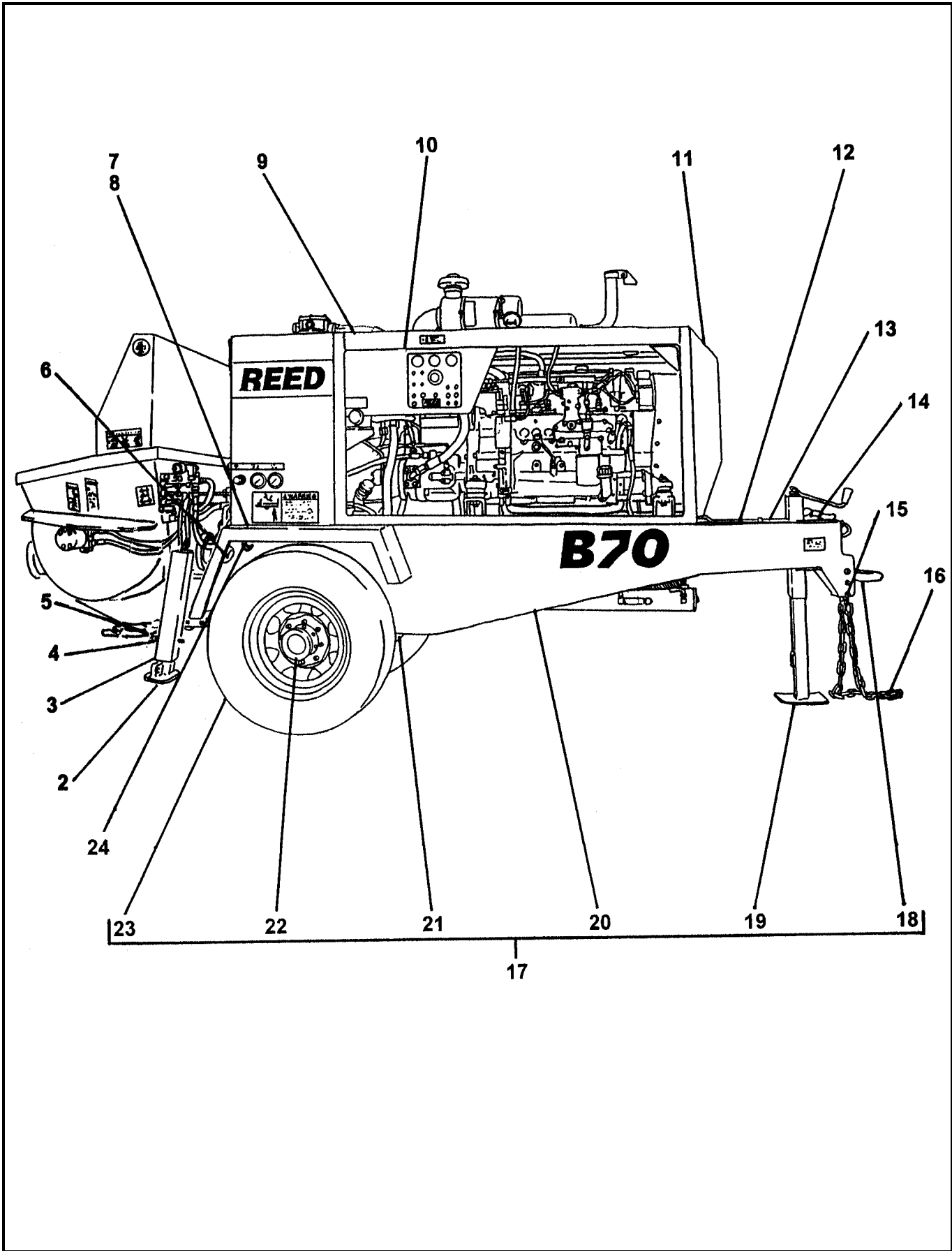

REVISION:



FRAME INSTALLATION

01 B70
PARTS
GROUP 70
FIGURE 01
PAGE 02

ITEM NO.	REED'S PARTS NO.	DESCRIPTION	QTY
		1 2 3 4 5	
-1	70-01	Installation, Frame (See Group 10, Figure 01 for NHA)	Ref
2	86553	• Weldment, Outrigger Inner	2
3	86550	• Weldment, Outrigger Outer Tube	2
4	85595	• Pin, Outrigger Safety	2
5	800418	• Lanyard, Q/R Pin	2
6	72948	• Light, Tail	2
7	85392	• Weldment, Right Fender	1
8	85393	• Weldment, Left Fender	1
9	85115	• Weldment, Lifting Structure	1
10	85391	• Cover, Control Box	1
11	85401	• Cover, Front	1
12	85338	• Cover, Tool Box	1
13	86533	• Assembly, Trailer Wiring Harness (See Schematic Section, Page 12 for REF)	1
14	77705	• Kit, Break Away	1
15	86243	• Connector, Chain	2
16	86242	• Chain, 3/8 Proof Coil GR 30 Zinc 6 FT	1
17	86187	• Assembly, Frame	1
18	71051	• • Lunette, 3 Inch Eye	1
19	85527	• • Weldment, Jack	1
20	86214	• • Weldment, Frame	1
21	85424	• • Axle	1
22	70-02	• • Assembly, Hub and Brake (See Group 70, Figure 02 for DET)	1
23	85423	• • Assembly, Wheel and Tire	2
24	72949	• Grommet, Trailer	3

DASH (-) ITEM NOT ILLUSTRATED

REVISION:

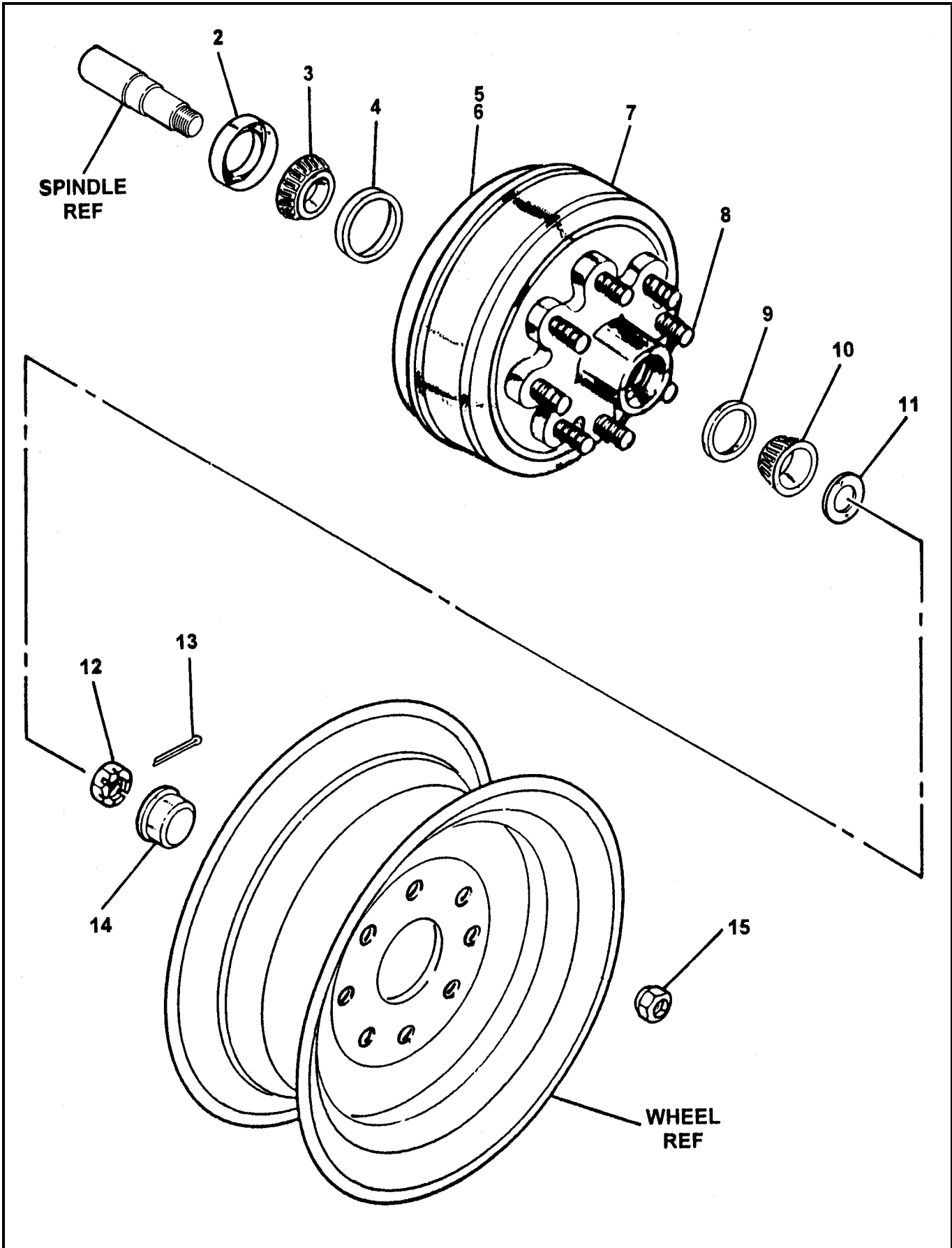



HUB AND BRAKE ASSEMBLY

01 B70

PARTS

GROUP 70

FIGURE 02

PAGE 02

ITEM NO.	REED'S PARTS NO.	DESCRIPTION					QTY
		1	2	3	4	5	
-1	70-02	Assembly, Hub and Brake (Left And Right Side) (See Group 70, Figure 01 for NHA)					Ref
2	86709	• Seal, Double Lip Grease					2
3	71094	• Bearing, Inner					2
4	71092	• Race, Inner Bearing					2
5	71056-L	• Assembly, Non-Operator Side Electric Brake (Set) (See Group 70, Figure 03 for DET)					1
6	71056-R	• Assembly, Operator Side Electric Brake (Set) (See Group 70, Figure 04 for DET)					1
7	86717	• Assembly, Drum And Hub					2
8	86716	• Stud, Wheel					16
9	86710	• Race, Outer Bearing					2
10	71098	• Bearing, Outer					2
11	86711	• Washer, Spindle					2
12	86712	• Nut, Spindle					2
13	86713	• Pin, Cotter					2
14	86714	• Cap, Dust					2
15	86715	• Nut, Wheel					16

DASH (-) ITEM NOT ILLUSTRATED

REVISION:



NON OPERATOR SIDE ELECTRIC BRAKE ASSEMBLY

01 B70
PARTS
GROUP 70
FIGURE 03
PAGE 01

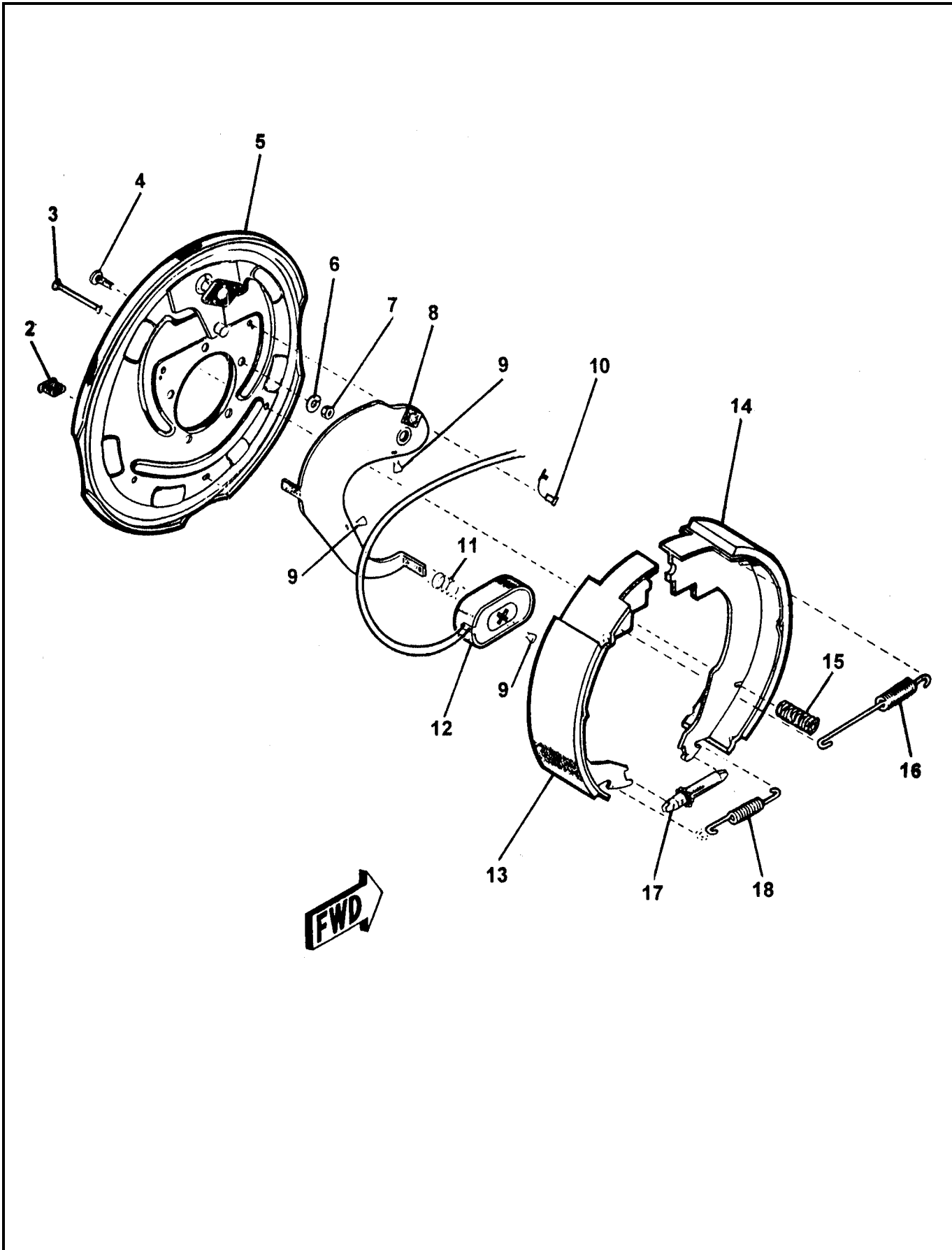

REVISION:



**NON OPERATOR SIDE
ELECTRIC BRAKE ASSEMBLY**

01 B70
PARTS
GROUP 70
FIGURE 03
PAGE 02

ITEM NO.	REED'S PARTS NO.	DESCRIPTION	QTY
		1 2 3 4 5	
-1	71056-L	Assembly, Non-Operator Side Electric Brake (See Group 70, Figure 02 for NHA)	Ref
2		• Slot, Plug Adjust	1
3		• Pin, Shoe Hold down	1
4		• Stud, Brake Mounting	5
5		• Assembly, Baking Plate	1
6		• Washer, Brake Lock	5
7		• Nut, Brake Mounting	5
8		• Lever, Non-Operator Side	1
9		• Clip, Wire and Magnet	3
10		• Relief, Strain	2
11		• Spring, Magnet	1
12		• Sub-Assembly, Magnet	1
13		• Shoe and Lining, Primary	1
14		• Shoe and Lining, Secondary	1
15		• Spring, Shoe Hold down	1
16		• Spring, Shoe Retractor	1
17		• Sub-Assembly, Adjuster Screw	1
18		• Spring, Adjuster Screw	1

DASH (-) ITEM NOT ILLUSTRATED



OPERATOR SIDE ELECTRIC BRAKE ASSEMBLY

01 B70
PARTS
GROUP 70
FIGURE 04
PAGE 01

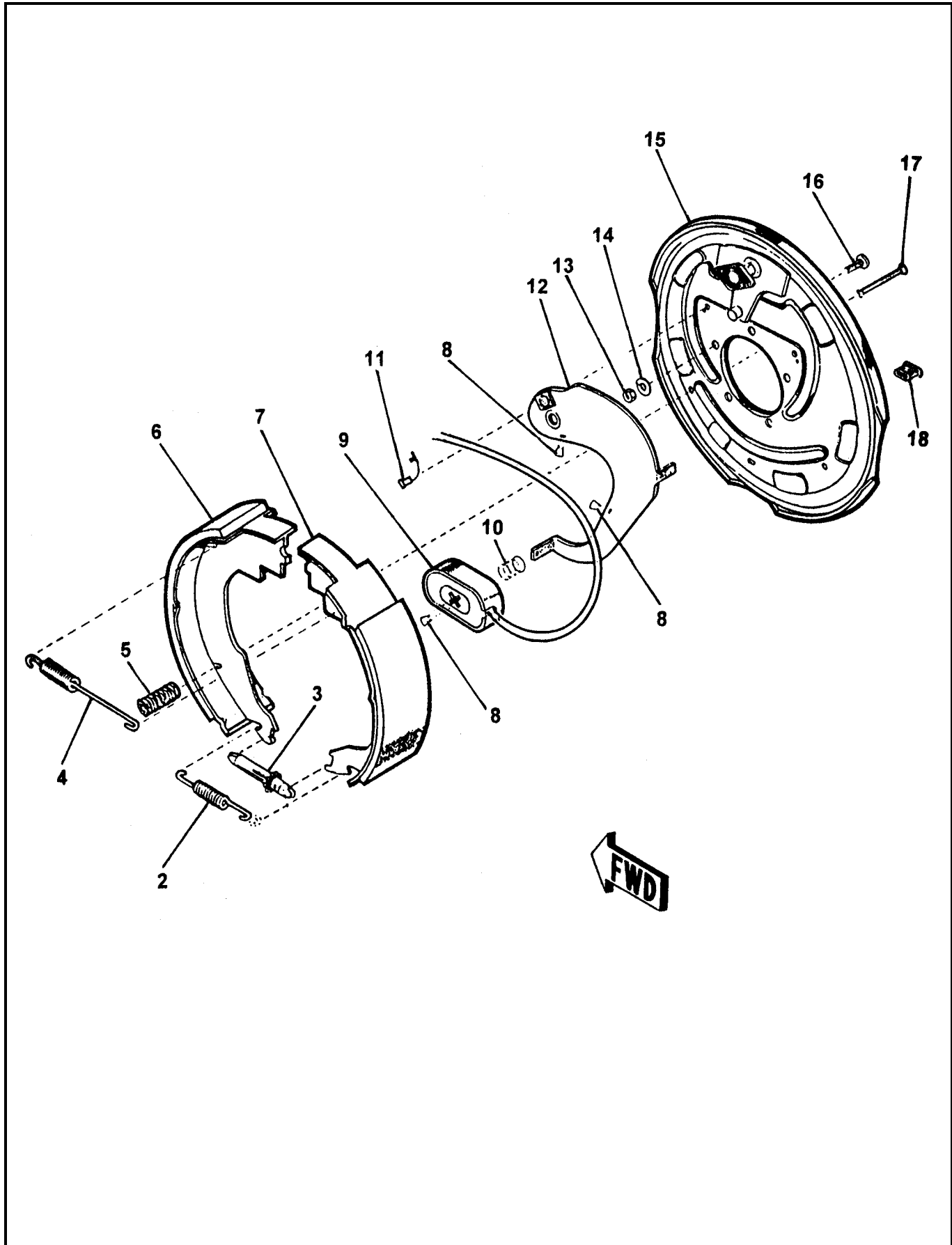

REVISION:



**OPERATOR SIDE
ELECTRIC BRAKE ASSEMBLY**

**01 B70
PARTS
GROUP 70
FIGURE 04
PAGE 02**

ITEM NO.	REED'S PARTS NO.	DESCRIPTION	QTY
		1 2 3 4 5	
-1	71056-R	Assembly, Operator Side Electric Brake (See Group 70, Figure 02 for NHA)	Ref
2		• Spring, Adjuster Screw	1
3		• Sub-Assembly, Adjuster Screw	1
4		• Spring, Shoe Retractor	1
5		• Spring, Shoe Hold down	1
6		• Shoe and Lining, Secondary	1
7		• Shoe and Lining, Primary	1
8		• Clip, Wire and Magnet	3
9		• Sub-Assembly, Magnet	1
10		• Spring, Magnet	1
11		• Relief, Strain	2
12		• Lever, Operator Side	1
13		• Nut, Brake Mounting	5
14		• Washer, Brake Lock	5
15		• Assembly, Baking Plate	1
16		• Stud, Brake Mounting	5
17		• Pin, Shoe Hold down	1
18		• Slot, Plug Adjust	1

DASH (-) ITEM NOT ILLUSTRATED

REVISION:



**TRAILER MOUNTED PUMP 01 MODEL B70
ILLUSTRATED PARTS MANUAL**

**01 B70
PARTS
GROUP 70
FIGURE 05
PAGE 01**



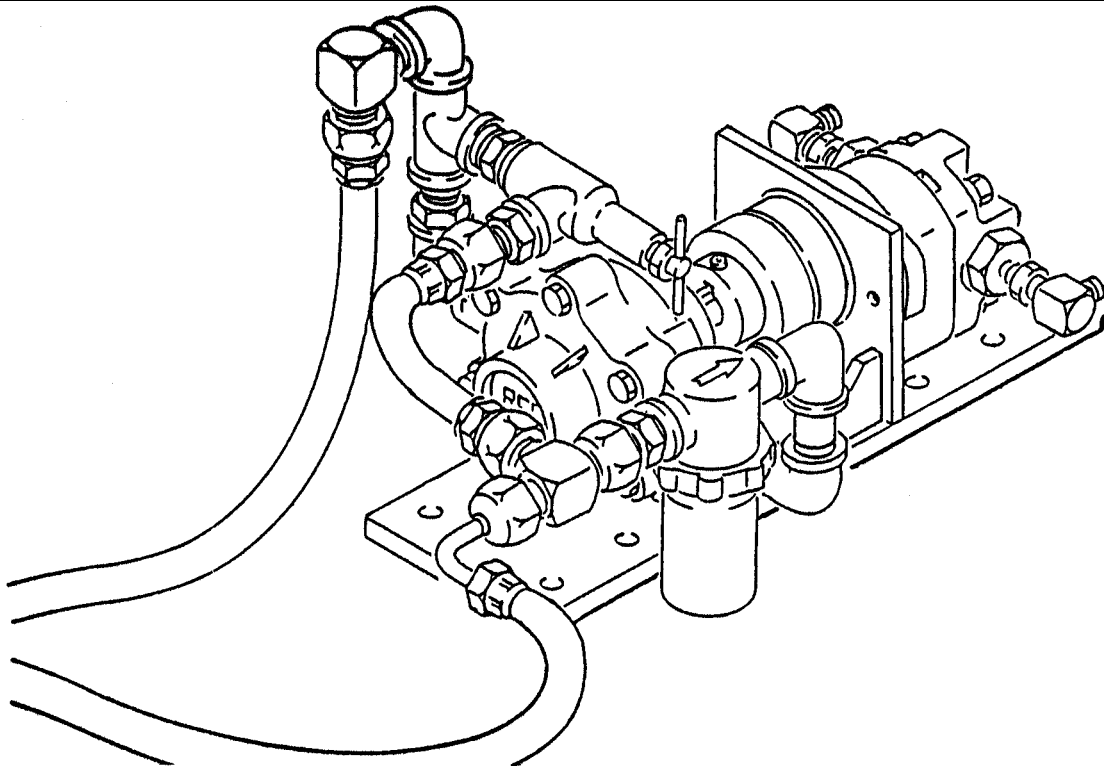

REED TRAILER MOUNTED CONCRETE PUMP 01 MODEL B70 ILLUSTRATED PARTS MANUAL GROUP 80 OPTIONAL INSTALLATION CONTAINS THE FOLLOWING FIGURES:

- FIGURE 00** TABLE OF CONTENTS
- FIGURE 01** OPTIONAL INSTALLATION
- FIGURE 02** LUBE SYSTEM ASSEMBLY
- FIGURE 03** 12 VOLT LUBE PUMP ASSEMBLY
- FIGURE 04** HOPPER VIBRATOR ASSEMBLY
- FIGURE 05** THROTTLE SOLENOID ASSEMBLY
- FIGURE 06** ACCUMULATOR CHARGE KIT
- FIGURE 07** OPTIONAL TOOL KIT ASSEMBLY
- FIGURE 08** ACTUATOR BRAKES ASSEMBLY
- FIGURE 09** WATER PUMP INSTALLATION
- FIGURE 10** WATER PUMP CONTROL VALVE ASSEMBLY
- FIGURE 11** WATER PUMP MOTOR ASSEMBLY
- FIGURE 12** WATER PUMP ASSEMBLY
- FIGURE 13** NON-OPERATOR SIDE HYDRAULIC BRAKE ASSEMBLY
- FIGURE 14** OPERATOR SIDE HYDRAULIC BRAKE ASSEMBLY
- FIGURE 15** HYDRAULIC OUTRIGGER CYLINDER ASSEMBLY
- FIGURE 16** 1 SPOOL CONTROL VALVE ASSEMBLY
- FIGURE 17** 1 SPOOL CONTROL VALVE SUB-ASSEMBLY
- FIGURE 18** 2 SPOOL CONTROL VALVE ASSEMBLY
- FIGURE 19** 2 SPOOL CONTROL VALVE SUB-ASSEMBLY
- FIGURE 20** SIDE DOOR ASSEMBLY
- FIGURE 21** 50 FEET STROKE COUNTER REMOTE CONTROLLER
- FIGURE 22** 100 FEET STROKE COUNTER REMOTE CONTROLLER



OPTIONAL INSTALLATION

01 B70
PARTS
GROUP 80
FIGURE 01
PAGE 01

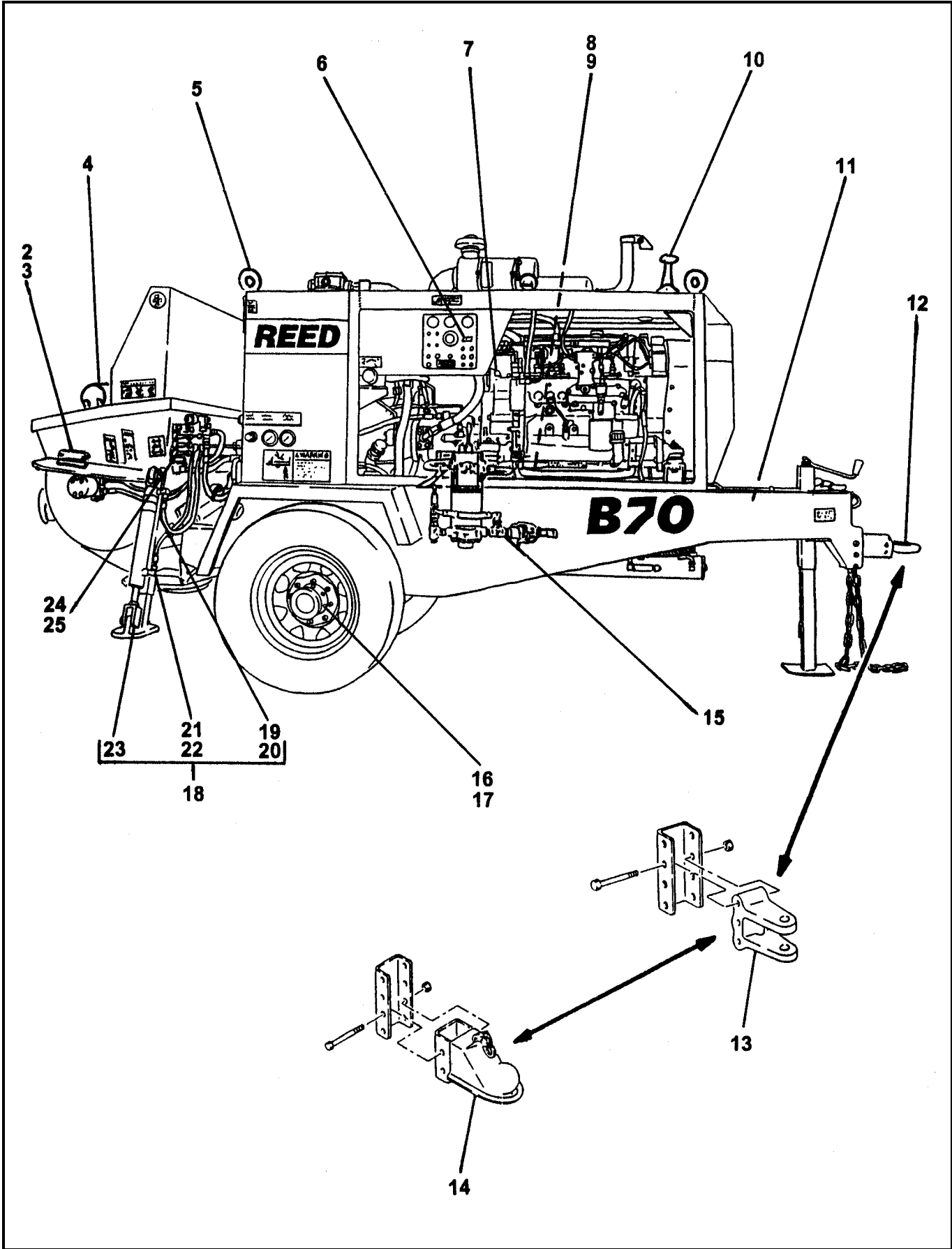

REVISION:



OPTIONAL INSTALLATION

01 B70
PARTS
 GROUP 80
 FIGURE 01
 PAGE 02

ITEM NO.	REED'S PARTS NO.	DESCRIPTION	QTY
		1 2 3 4 5	
-1	80-01	Installation, Optional (See Group 10, Figure 01 for NHA)	Ref
2	80-02	• Assembly, Lube System (See Group 80, Figure 02 for DET)	1
3	78736	• Assembly, Lube Pump (See Group 80, Figure 03 for DET)	1
4	71429	• Assembly, Hopper Vibration (See Group 80, Figure 04 for DET)	1
5	85810	• Assembly, Optional Lifting	1
6	85774	• Assembly, Stroke Counter	1
7	77012	• Assembly, Throttle Solenoid (See Group 80, Figure 05 for DET)	1
8	71460	• Kit, Accumulator Charge (See Group 80, Figure 06 for DET)	1
9	30-11	• Kit, Bladder Repair (See Group 30, Figure 11 for REF)	1
10	85818	• Assembly, Radio Remote Control (See Group 50, Figure 05 for REF)	1
11	79020	• Assembly, Optional Tool Kit (See Group 80, Figure 07 for DET)	1
12	75413	• Assembly, Actuator Brake (See Group 80, Figure 08 for DET)	1
13	71050	• Assembly, Adjustable 1 Inch Clevis	1
14	71099	• Assembly, Adjustable Ball Coupler 2 – 5/16"	1
15	86400	• Installation, Water Pump (See Group 80, Figure 09 for DET)	1
16	80-13	• Assembly, Non-Operator Side Hydraulic Brake (See Group 80, Figure 13 for DET)	1
17	80-14	• Assembly, Operator Side Hydraulic Brake (See Group 80, Figure 14 for DET)	1
18	85677	• Assembly, Hydraulic Outrigger	1
19	85685	• • Assembly, Tube	2
20	85686	• • Assembly, Tube	2
21	85659-010	• • Assembly, Hose (See Schematic Section, Figure 05 for REF)	4
22		• • Elbow, 90	4
23	85640	• • Assembly, Hydraulic Outrigger Cylinder (See Group 80, Figure 15 for DET)	2
24	80-16	• Assembly, 1 Spool Valve (See Group 80, Figure 16 for DET)	1
25	80-18	• Assembly, 2 Spool Valve (See Group 80, Figure 18 for DET)	1
-26	85943	• Assembly, Side Door (See Group 80, Figure 20 for DET)	1
-27	85960	• Assembly, 50 Feet Remote Control Stroke Counter (See Group 80, Figure 21 for DET)	1
-28	85960A	• Assembly, 100 Feet Remote Control Stroke Counter (See Group 80, Figure 22 for DET)	1

DASH (-) ITEM NOT ILLUSTRATED

REVISION:

LUBE SYSTEM ASSEMBLY

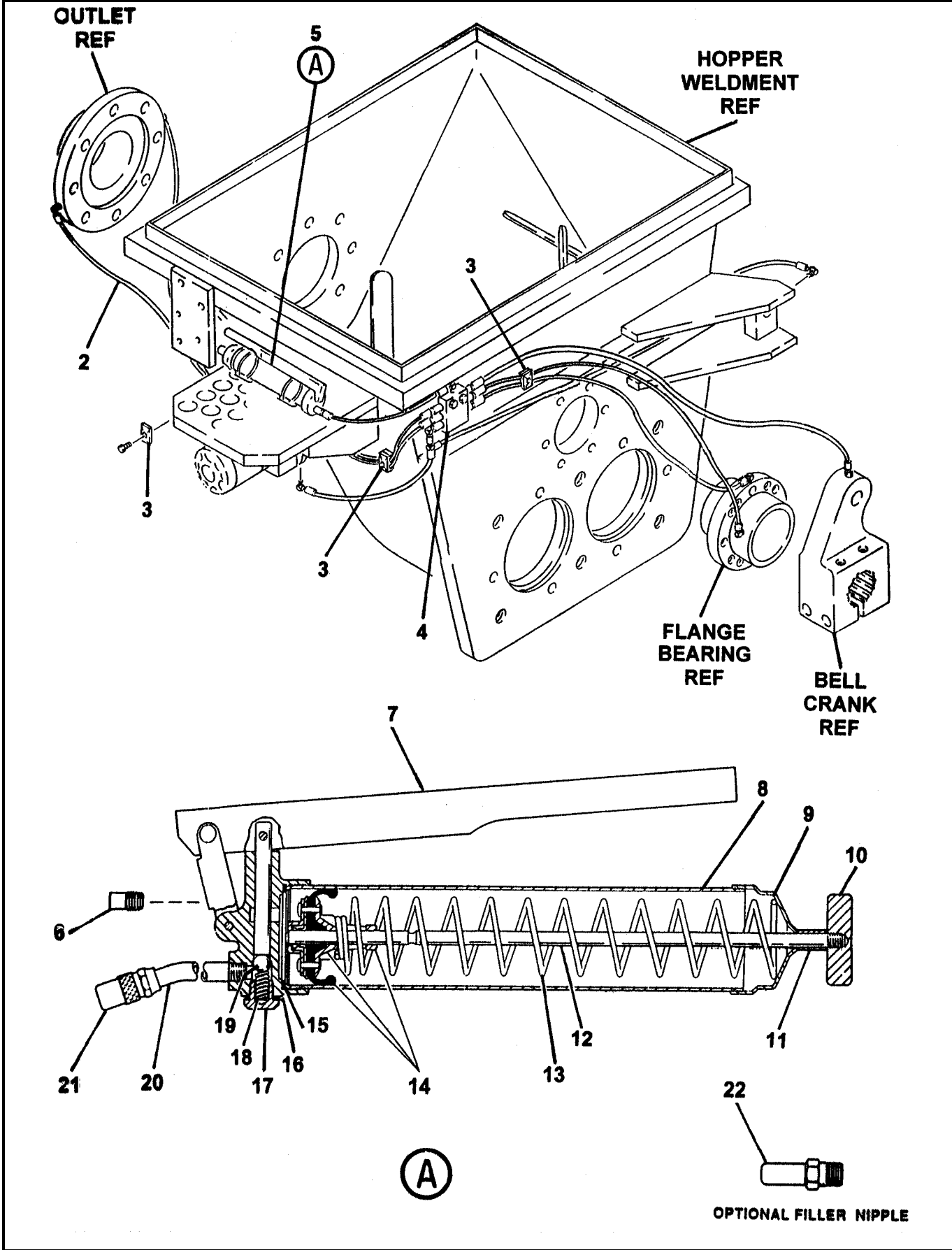

REVISION:



LUBE SYSTEM ASSEMBLY

01 B70
PARTS
GROUP 80
FIGURE 02
PAGE 02

ITEM NO.	REED'S PARTS NO.	DESCRIPTION	QTY
		1 2 3 4 5	
-1	80-02	Assembly, Lube System (See Group 80, Figure 01 for NHA)	Ref
2		• Assembly, Lube Hose	A/R
3	75436	• Clamp, Pipe	3
4	72355	• Block, 6 Station Lube System	1
5	78532	• Gun, Grease	1
6		• • Plug	1
7		• • Handle, Pumping	1
8		• • Tube, Container	1
9		• • Cap, Tube	1
10		• • Handle, Follower	1
11		• • Spacer	1
12		• • Rod, Follower	1
13		• • Spring	1
14		• • Sub-Assembly, Follower	1
15		• • Packing, Container	1
16		• • Gasket	1
17		• • Housing, Spring	1
18		• • Spring	1
19		• • Ball, Check	1
20		• • Extension, Nozzle	1
21		• • Coupler, Hydraulic	1
22		• • Nipple, Filler (Optional Item)	1

DASH (-) ITEM NOT ILLUSTRATED

LUBE PUMP ASSEMBLY

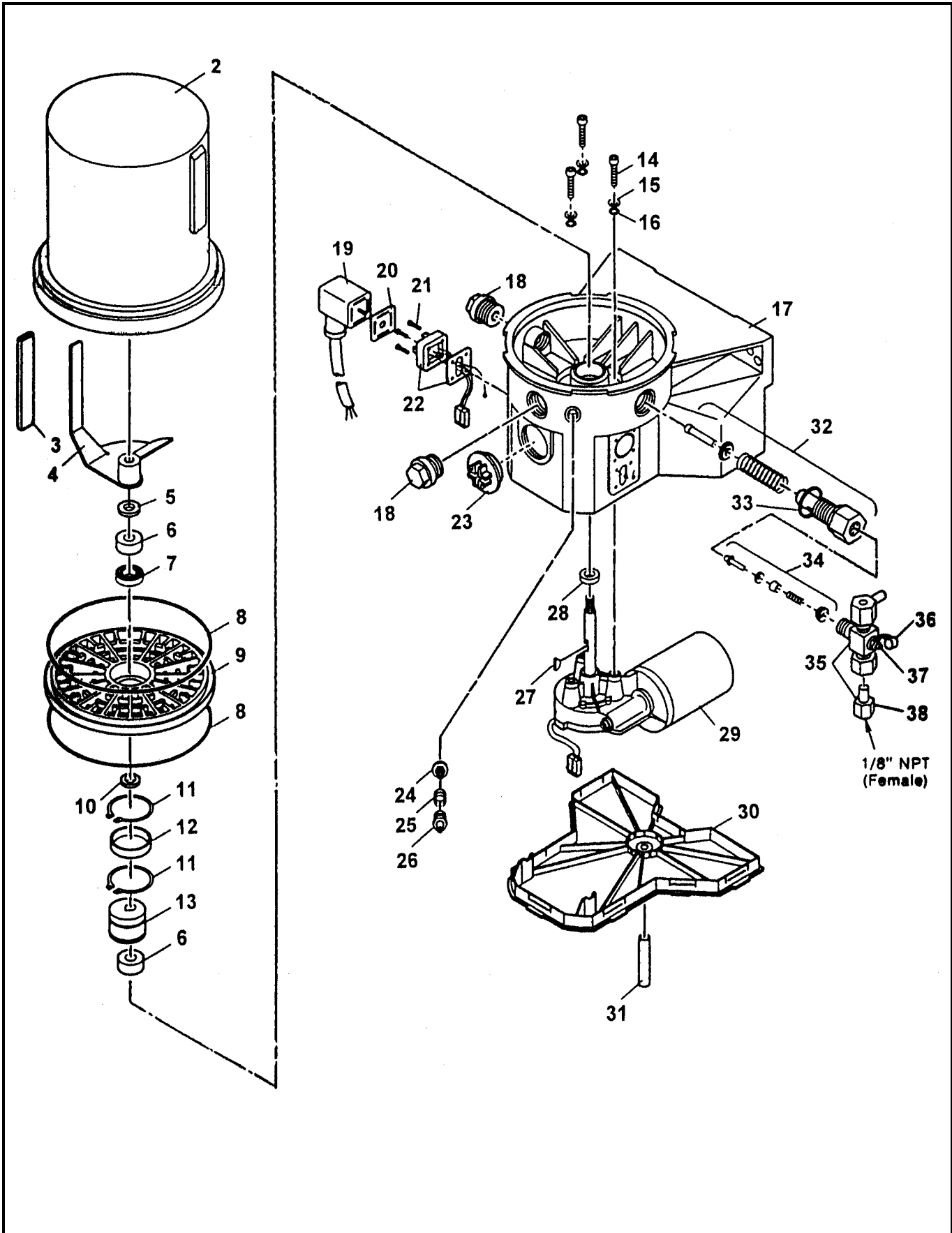

REVISION:



LUBE PUMP ASSEMBLY

01 B70

PARTS

GROUP 80

FIGURE 03

PAGE 02

ITEM NO.	REED'S PARTS NO.	DESCRIPTION	QTY
		1 2 3 4 5	
-1	78736	Assembly, Lube Pump (See Group 80, Figure 01 for NHA)	Ref
2		• Reservoir	1
3		• House	1
4		• Paddle, Stirring	1
5		• Washer	1
6		• Ring, Bearing	2
7		• Bearing	1
8		• O-Ring	2
9		• Plate, Intermediate	1
10		• Shim	1
11		• Ring, Snap	2
12		• Ring, Inner	1
13		• Cam, Eccentric	1
14		• Screw	3
15		• Washer	3
16		• O-Ring	3
17		• Housing, Pump	1
18		• Plug, Closure	2
19		• Socket with Cord	1
20		• Packing, Flat	1
21		• Screw	4
22		• Plug	1
23		• Plug, Sealing	1
24		• Insert, Filter	1
25		• Spring	1
26		• Fitting, Grease	1
27		• Key, Woodruff	1
28		• Seal, Radial	1
29		• Motor, 12 VDC	1
30		• Cover, Housing	1
31		• Hose	1
32		• Element, Pump	1
33		• Gasket	1
34		• Valve, Check	1
35		• Assembly, Pressure Reliefs	1
36		• Cap, Grease	1
37		• Fitting, Grease	1
38		• Assembly, Adapter for Relief	1

DASH (-) ITEM NOT ILLUSTRATED

REVISION:



HOPPER VIBRATOR ASSEMBLY

01 B70
PARTS
GROUP 80
FIGURE 04
PAGE 01

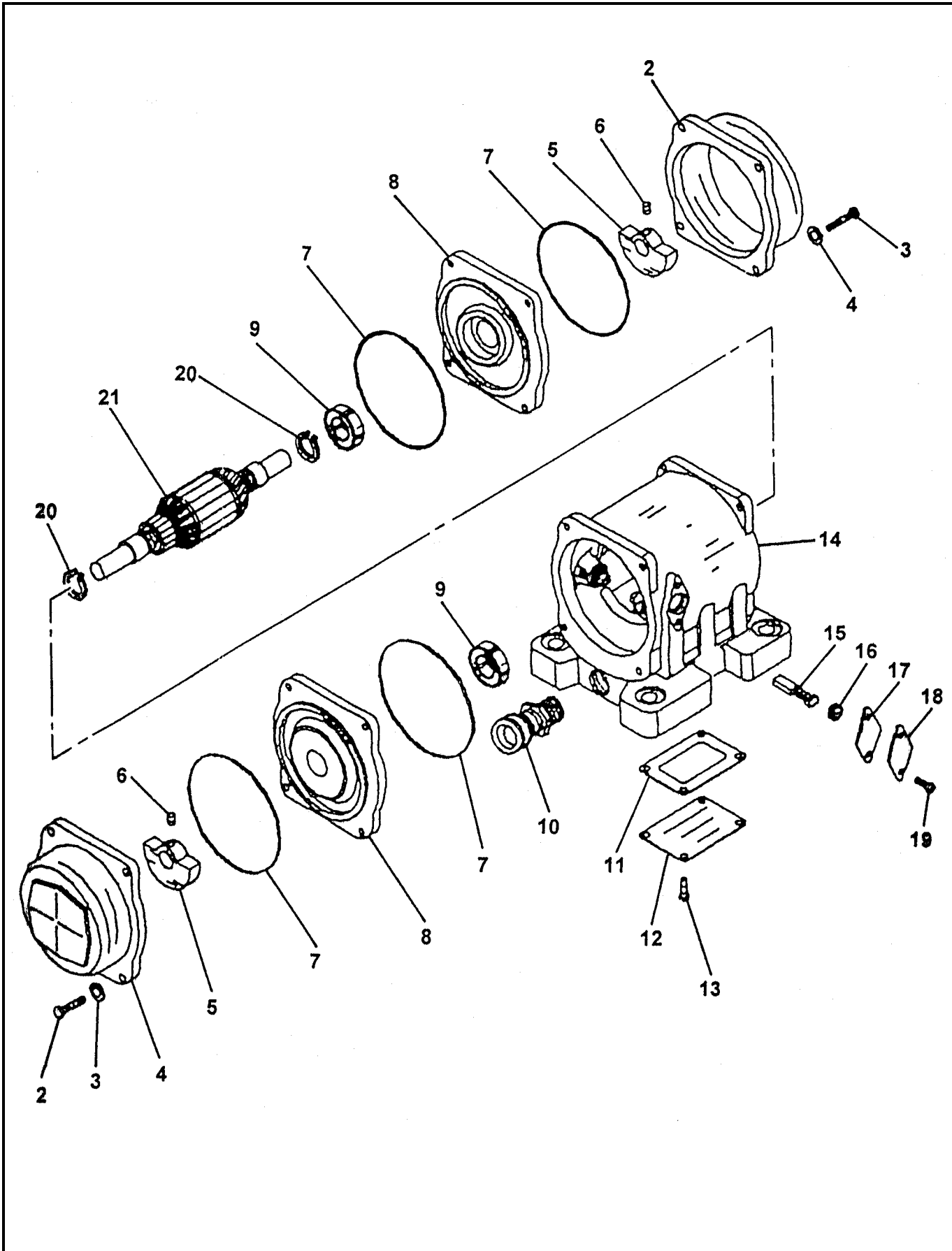

REVISION:



HOPPER VIBRATOR ASSEMBLY

01 B70

PARTS

GROUP 80

FIGURE 04

PAGE 02

ITEM NO.	REED'S PARTS NO.	DESCRIPTION					QTY
		1	2	3	4	5	
-1	71429	Assembly, Hopper Vibrator (See Group 80, Figure 01 for NHA)					Ref
2		• Cap, End					2
3		• Bolt (attaching parts)					8
4		• Washer, Lock (attaching parts)					8
5		• Weight					2
6		• Screw, Set (attaching parts)					2
7		• O-Ring					4
8		• Bell, End					2
9		• Bearing					2
10		• Holder, Cord					1
11		• Gasket					1
12		• Cover, Box					1
13		• Screw (attaching parts)					4
14		• Sub-Assembly, Housing					1
15		• Brush					1
16		• Cap, Brush					2
17		• Gasket					2
18		• Cover, Brush					2
19		• Screw (attaching parts)					4
20		• Ring, Snap					2
21		• Assembly, Armature					1

DASH (-) ITEM NOT ILLUSTRATED

REVISION:



THROTTLE SOLENOID ASSEMBLY

01 B70
PARTS
GROUP 80
FIGURE 05
PAGE 01

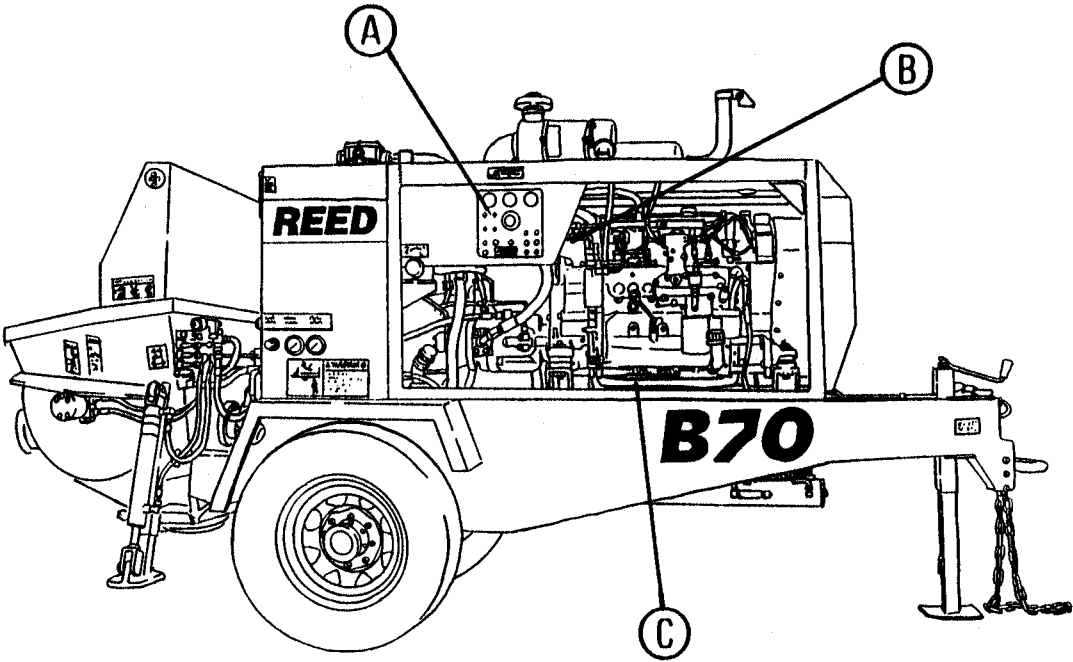

CONTROL BOX REF
(P/N:85358)

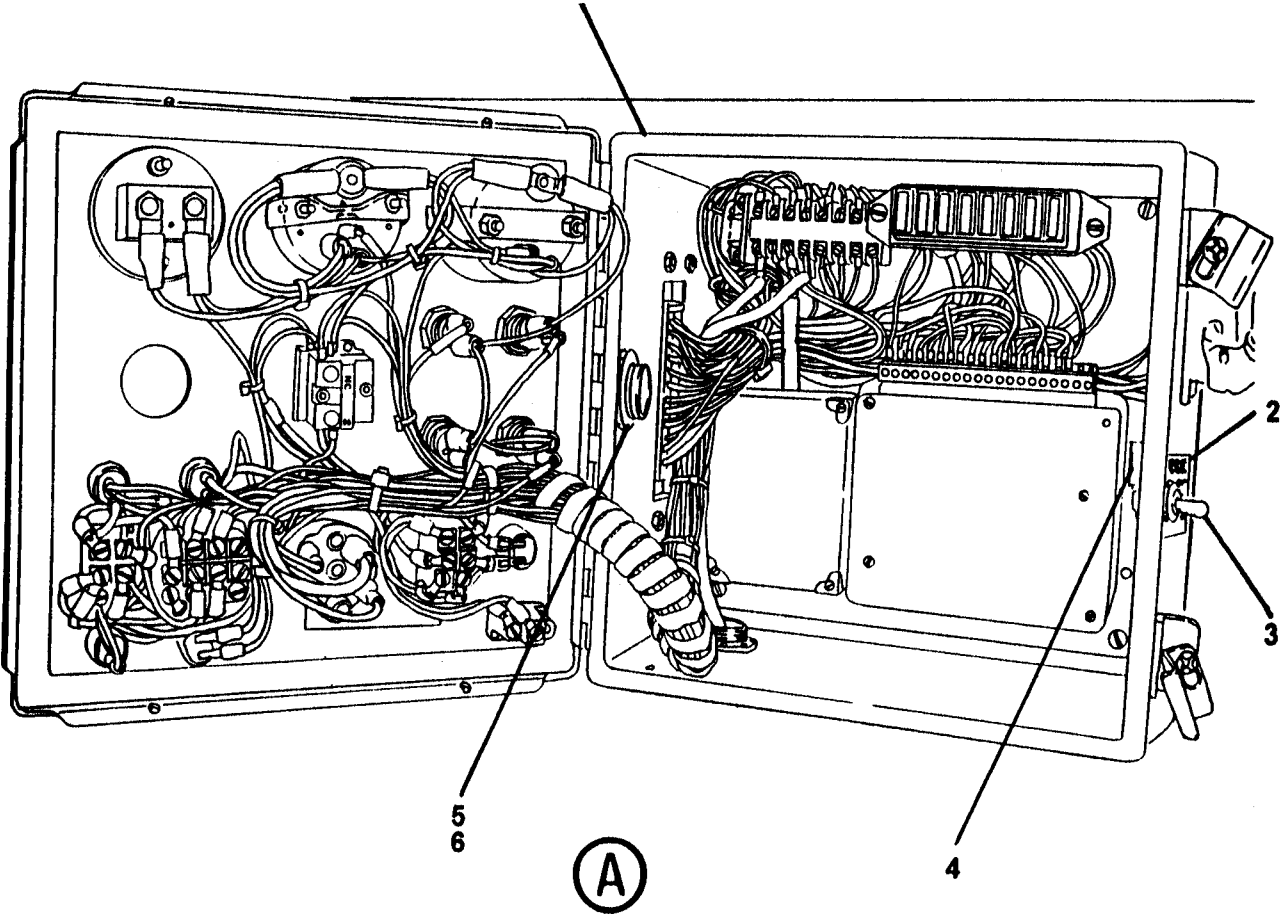



THROTTLE SOLENOID ASSEMBLY

01 B70
PARTS
GROUP 80
FIGURE 05
PAGE 02

ITEM NO.	REED'S PARTS NO.	DESCRIPTION	QTY
		1 2 3 4 5	
-1	86134	Assembly, Throttle Solenoid (See Group 80, Figure 01 for NHA)	Ref
2	86131	• Case, Charge Kit	1
3	72965	• Switch, ON/OFF/ON Toggle	1
4	71955	• Relay, 12V	1
5	10523	• Relief, Strain	1
6	10528	• Nut, Bonding Type Lock	1
7	77012	• Solenoid, Throttle	1
8		• • Solenoid	1
9	71955	• • Relay, 12V	1
10	72294	• • Bolt, Throttle Control	1
11	78202	• • Coupler	1
12	85615	• Cable, 7 Feet 14AWG-2C	A/R
13	85617	• Cable, 6 Feet 14AWG-4C	A/R
14	801359	• Holder, Fuse with Cover	1
15	801360	• Fuse, 50AMP	1
16		• Bolt, Hex	1
17		• Washer, flat	2
18		• Nut, Lock	1

DASH (-) ITEM NOT ILLUSTRATED



THROTTLE SOLENOID ASSEMBLY

01 B70

PARTS

GROUP 80

FIGURE 05

PAGE 03

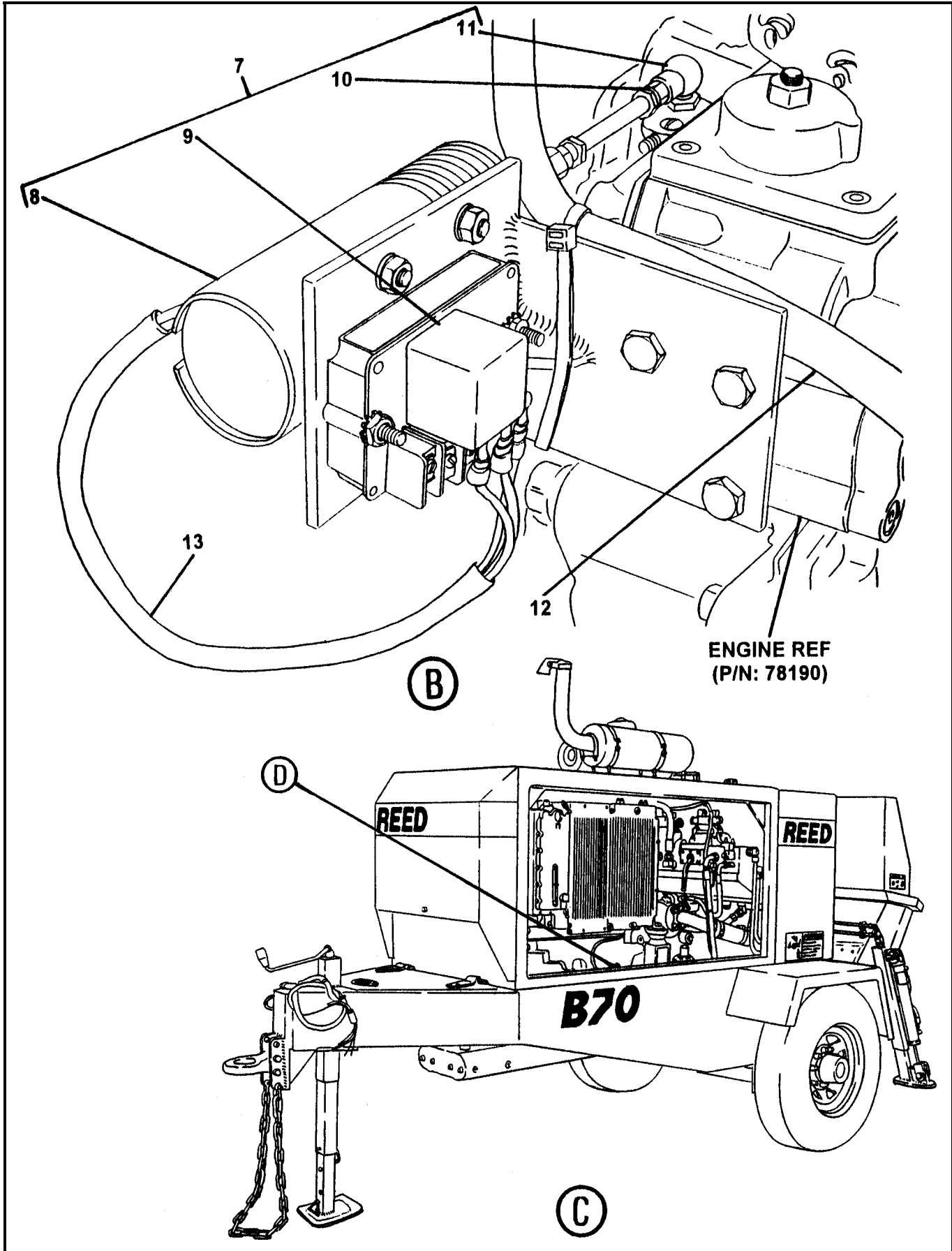

ENGINE REF
(P/N: 78190)

REVISION:



THROTTLE SOLENOID ASSEMBLY

01 B70
PARTS
 GROUP 80
 FIGURE 05
 PAGE 04

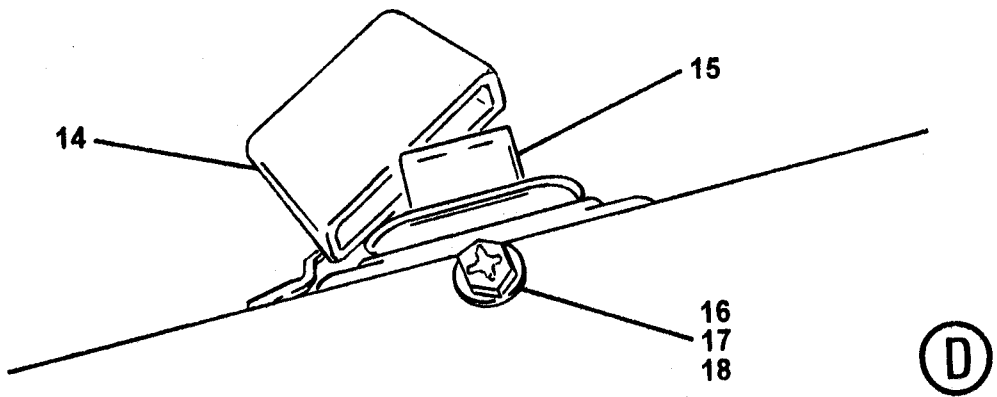

ITEM NO.	REED'S PARTS NO.	DESCRIPTION					QTY
		1	2	3	4	5	
-1	86134	Assembly, Throttle Solenoid (See Group 80, Figure 01 for NHA)					Ref
2	86131	• Case, Charge Kit					1
3	72965	• Switch, ON/OFF/ON Toggle					1
4	71955	• Relay, 12V					1
5	10523	• Relief, Strain					1
6	10528	• Nut, Bonding Type Lock					1
7	77012	• Solenoid, Throttle					1
8		• • Solenoid					1
9	71955	• • Relay, 12V					1
10	72294	• • Bolt, Throttle Control					1
11	78202	• • Coupler					1
12	85615	• Cable, 7 Feet 14AWG-2C					A/R
13	85617	• Cable, 6 Feet 14AWG-4C					A/R
14	801359	• Holder, Fuse with Cover					1
15	801360	• Fuse, 50AMP					1
16		• Bolt, Hex					1
17		• Washer, flat					2
18		• Nut, Lock					1

DASH (-) ITEM NOT ILLUSTRATED



ACCUMULATOR CHARGE KIT

01 B70

PARTS

GROUP 80

FIGURE 06

PAGE 01

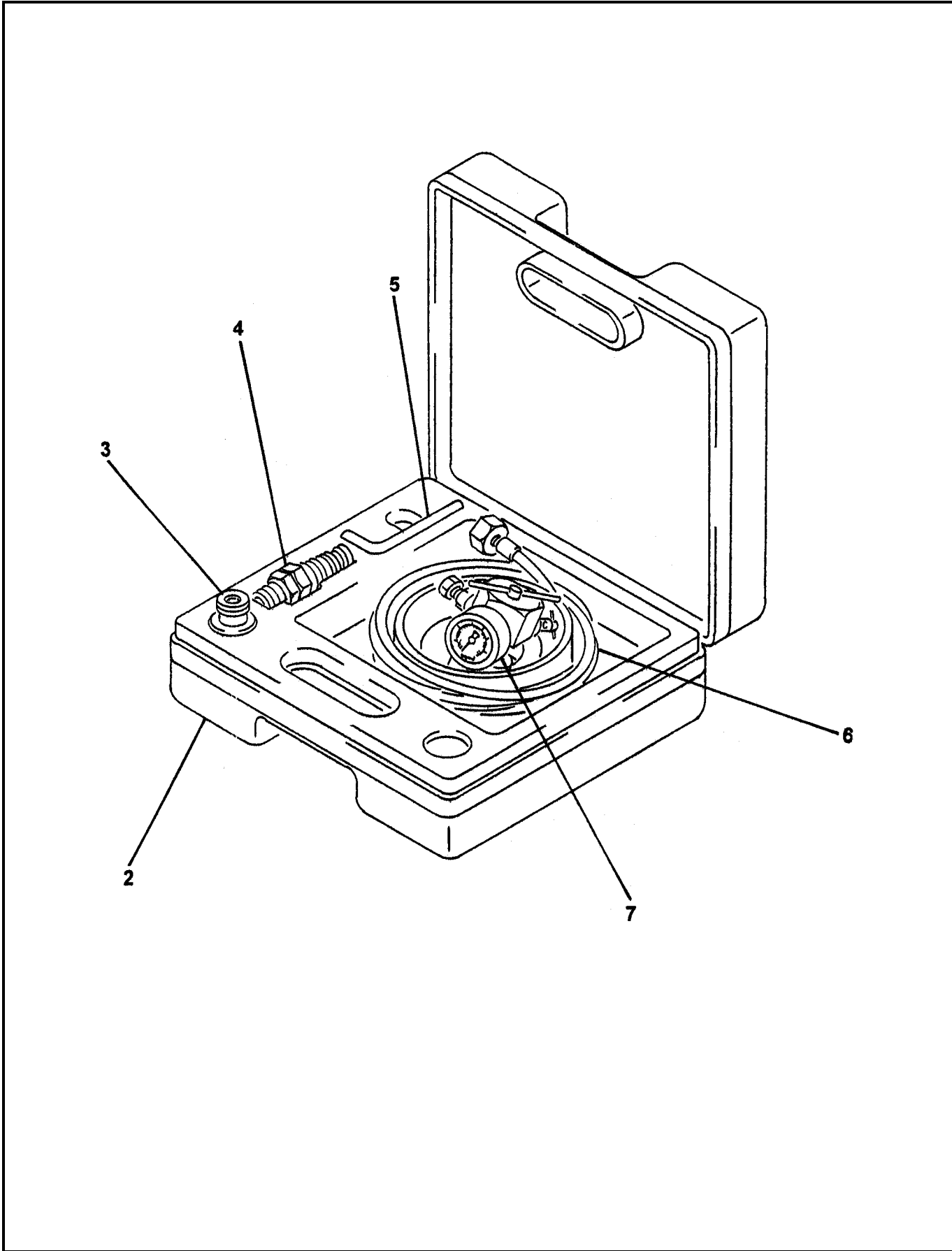

REVISION:



ACCUMULATOR CHARGE KIT

01 B70
PARTS
GROUP 80
FIGURE 06
PAGE 02

ITEM NO.	REED'S PARTS NO.	DESCRIPTION	QTY
		1 2 3 4 5	
-1	71460	Kit, Accumulator Charge (See Group 80, Figure 01 for NHA)	Ref
2		• Case, Charge Kit	1
3		• Adapter, FPK / SB	1
4		• Adapter, G4	1
5		• Wrench, Allen	1
6		• Hose, Charging	1
7		• Unit, FPK Charging and Gagging	1

DASH (-) ITEM NOT ILLUSTRATED



OPTIONAL TOOL KIT ASSEMBLY

01 B70

PARTS

GROUP 80

FIGURE 07

PAGE 01

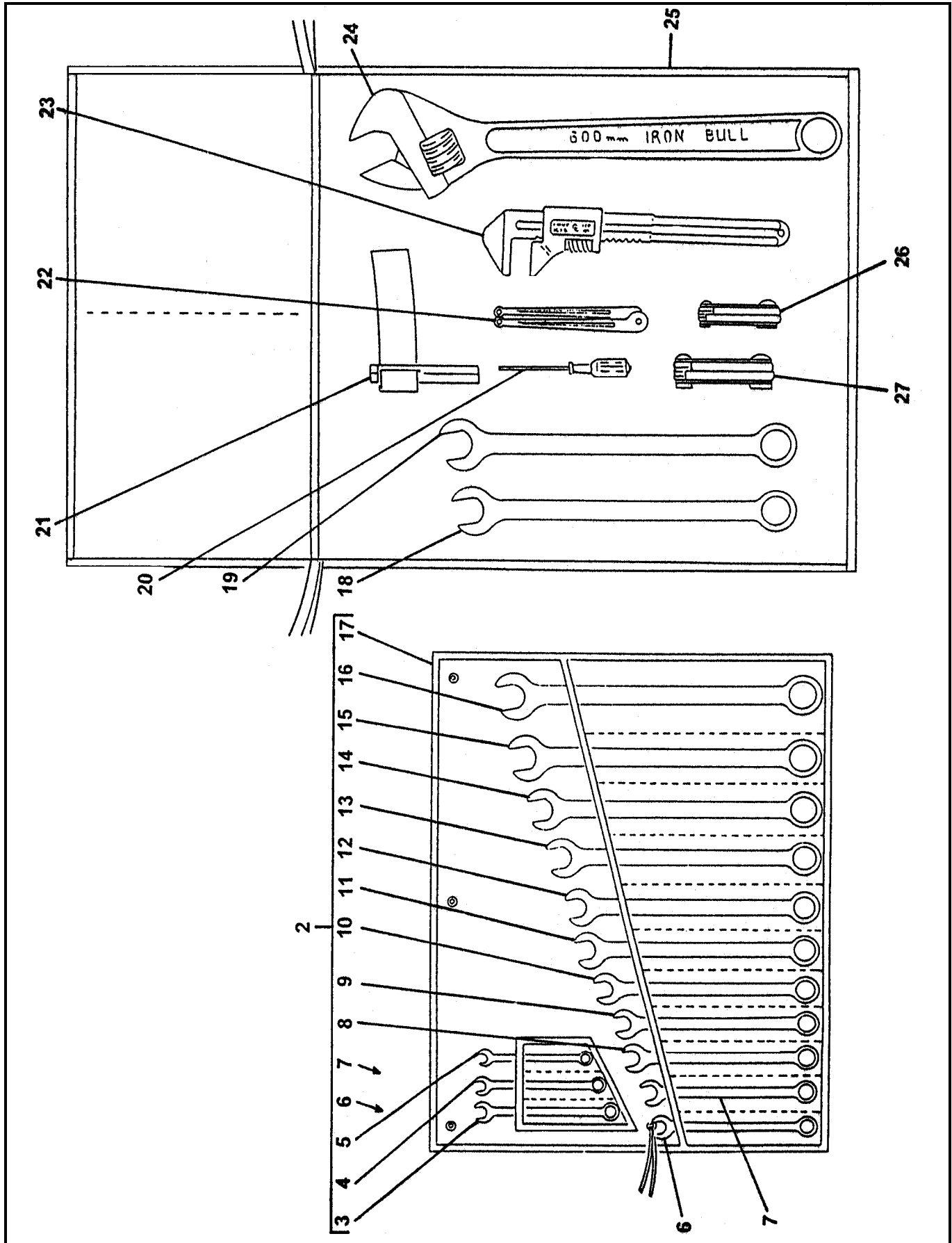

REVISION:



OPTIONAL TOOL KIT ASSEMBLY

01 B70

PARTS

GROUP 80

FIGURE 07

PAGE 02

ITEM NO.	REED'S PARTS NO.	DESCRIPTION	QTY
		1 2 3 4 5	
-1	79020	Assembly, Optional Tool Kit (See Group 80, Figure 01 for NHA)	Ref
2	79037	• Kit, Wrench	1
3		• • Wrench, 1/2 Inch	1
4		• • Wrench, 7/16 Inch	1
5		• • Wrench, 3/8 Inch	1
6		• • Wrench, 9/16 Inch	1
7		• • Wrench, 5/8 Inch	1
8		• • Wrench, 11/16 Inch	1
9		• • Wrench, 3/4 Inch	1
10		• • Wrench, 13/16 Inch	1
11		• • Wrench, 7/8 Inch	1
12		• • Wrench, 15/16 Inch	1
13		• • Wrench, 1 Inch	1
14		• • Wrench, 1-1/16 Inch	1
15		• • Wrench, 1-1/8 Inch	1
16		• • Wrench, 1-1/4 Inch	1
17		• • Wrap, Plastic	1
18	79036	• Wrench, 1-3/8 Inch	1
19	79028	• Wrench, 1-1/2 Inch	1
20	79038	• Screwdriver	1
21	79814	• Wrench, Strap (for Filter)	1
22	79325	• Wrench, Spanner	1
23	79031	• Wrench, Monkey	1
24	79032	• Wrench, Adjustable 24 Inch	1
25	77502	• Bag, Tool	1
26	79030	• Set, Metric Allen Key (2-8 mm)	1
27	79029	• Set, Standard Allen Key (3/16-3/8 Inch)	1

DASH (-) ITEM NOT ILLUSTRATED

REVISION:



ACTUATOR BRAKES ASSEMBLY

01 B70

PARTS

GROUP 80

FIGURE 08

PAGE 01

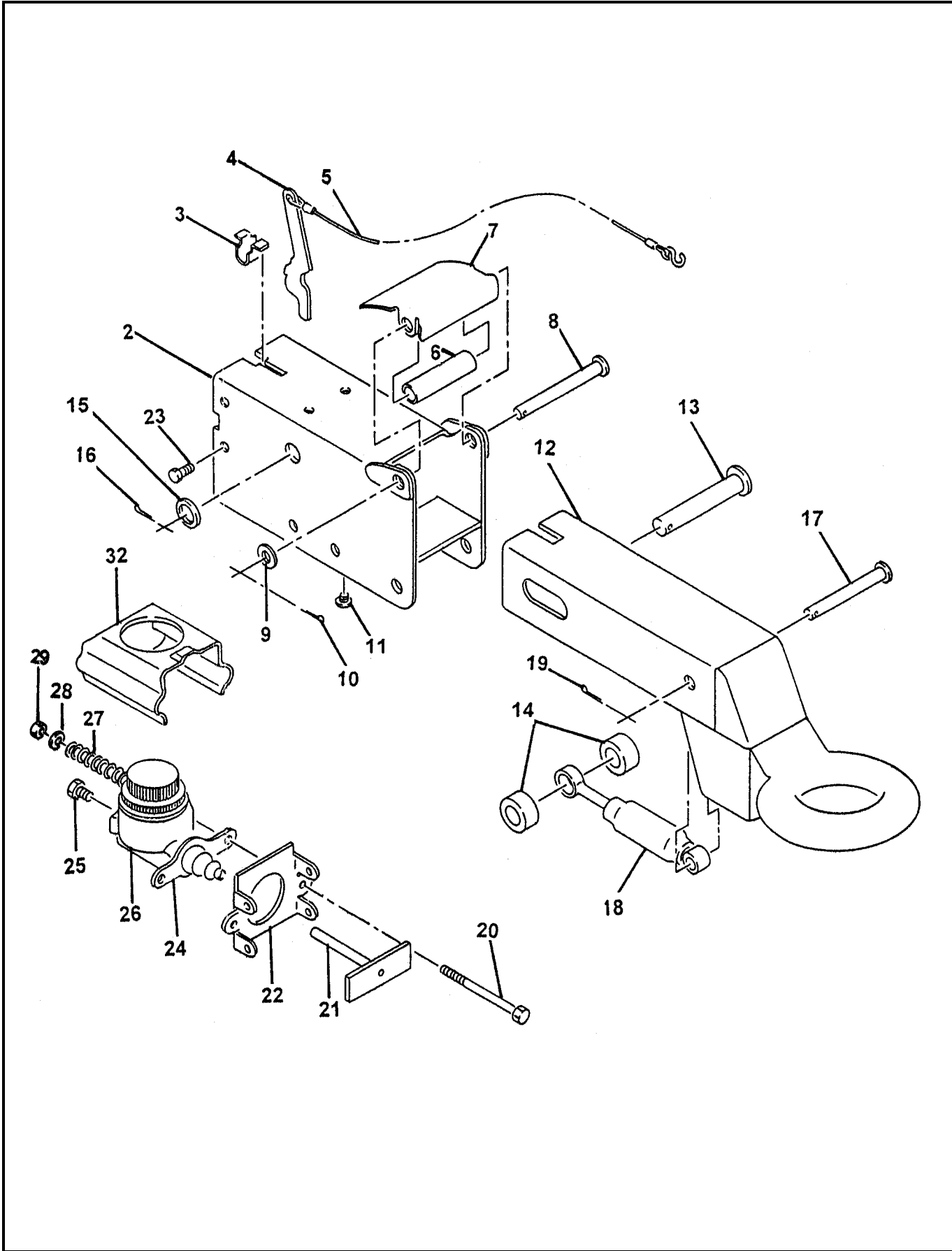

REVISION:



ACTUATOR BRAKES ASSEMBLY

01 B70
PARTS
GROUP 80
FIGURE 08
PAGE 02

ITEM NO.	REED'S PARTS NO.	DESCRIPTION	QTY
		1 2 3 4 5	
-1	75413	Assembly, Actuator Brakes (See Group 80, Figure 01 for NHA)	Ref
2		• Case, Outer	1
3		• Spring, Breakaway	1
4		• Lever, Breakaway Pin	1
5		• • S-Hook	1
6		• Roller, Front	1
7		• Cover, Front Roller	1
8		• Pin, Front Roller	1
9		• Washer, Front Roller Pin	1
10		• Pin, Cotter	1
11		• Bearing	2
12		• Lunette Eye, Inner Side	1
13		• Pin, Master	1
14		• Roller, Rear	2
15		• Washer, Master Pin	1
16		• Pin, Cotter	1
17		• Pin, Damper	1
18		• Damper	1
19		• Pin, Cotter	1
20		• Bolt, Hex	2
21		• Rod, Push	1
22		• Plate, Cylinder Mounting	1
23		• Bolt, Self Topping	4
24		• Cylinder, Master	1
25		• Connector, Orifice	1
26		• Cap, Master Cylinder with Gasket	1
27		• Spring	2
28		• Washer	2
29		• Nut, hex	2

DASH (-) ITEM NOT ILLUSTRATED



WATER PUMP INSTALLATION

01 B70
PARTS
GROUP 80
FIGURE 09
PAGE 01

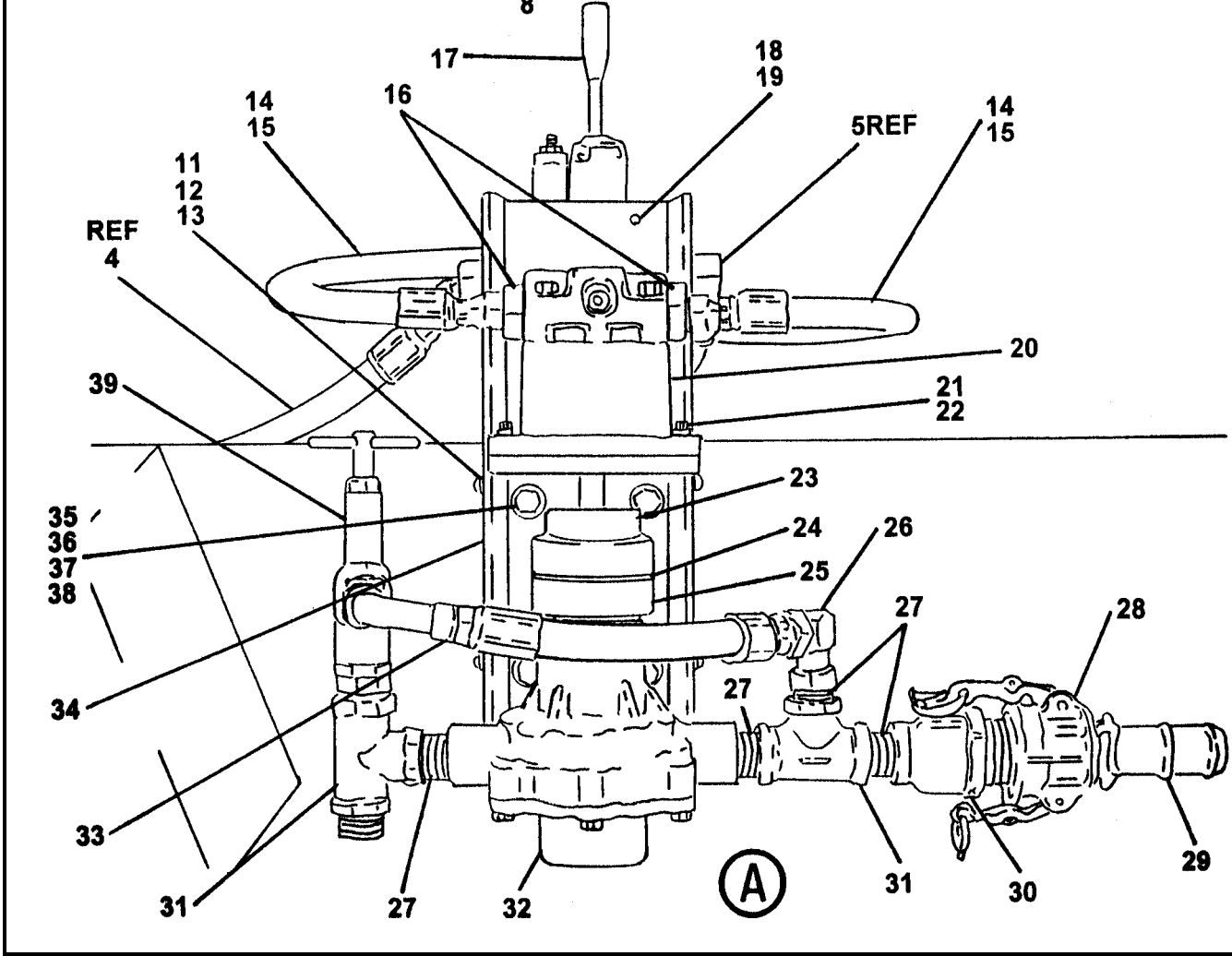
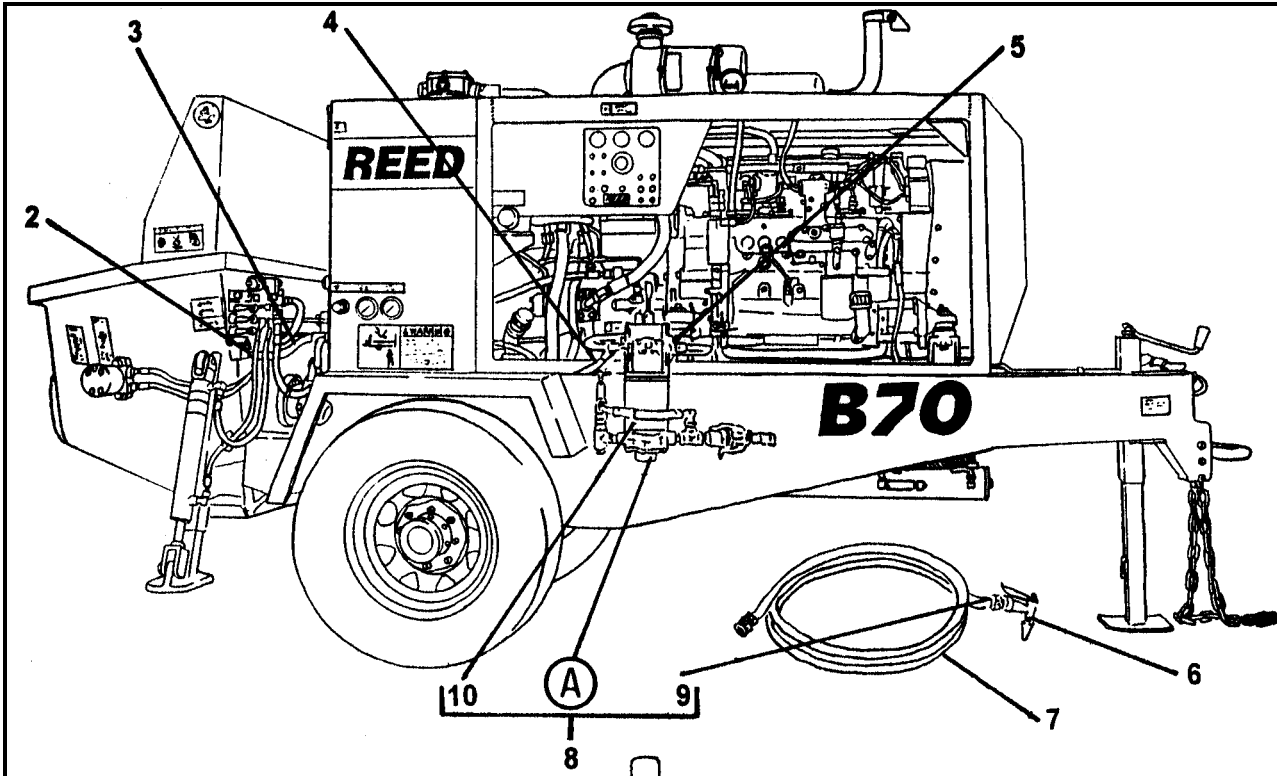

REVISION:



WATER PUMP INSTALLATION

01 B70
PARTS
 GROUP 80
 FIGURE 09
 PAGE 02

ITEM NO.	REED'S PARTS NO.	DESCRIPTION	QTY
-1	86400	Installation, Water Pump (See Group 80, Figure 01 for NHA)	Ref
2	86384	• Sleeve, Power Beyond	1
3		• Assembly, Hose	1
4		• Assembly, Hose	1
5		• Assembly, Hose	1
6	800098	• Nozzle, Garden Hose	1
7	86267	• Hose, Garden 20 FT	1
8	86200	• Kit, Wash Pump	1
9	800371	• • Fitting, Garden Hose	1
10	86199	• • Cover, Wash Pump	1
11		• • Screw (attaching parts)	4
12		• • Washer, SPL Lock (attaching parts)	4
13		• • Washer, Flat (attaching parts)	4
14		• • Fitting, 90	2
15	85658-002	• • Assembly, Hose	2
16		• • Fitting, STR	2
17	86397	• • Assembly, Water Pump Control Valve (See Group 80, Figure 10 for DET)	1
18		• • Bolt (attaching parts)	2
19		• • Washer, SPL Lock (attaching parts)	2
20	78152	• • Assembly, Water Pump Motor (See Group 80, Figure 11 for DET)	1
21		• • Bolt, Hex (attaching parts)	2
22		• • Washer, SPL Lock (attaching parts)	2
23	78153	• • Coupling, Wash Motor	1
24	78155	• • Spider	1
25	78154	• • Coupling, Wash Pump	1
26		• • Fitting, 90	1
27	40047	• • Nipple, Close, Pipe	5
28	10947	• • Coupling, Female Cam / Groove	1
29	10948	• • Coupling, Male Cam / Groove	1
30	86398	• • Reducer, Bell	1
31	10228	• • Tee	2
32	78157	• • Assembly, Water Pump (See Group 80, Figure 12 for DET)	1
33	85657-022	• • Assembly, Hose	1
34	86196	• • Weldment, Wash Pump Base	1
35		• • Bolt, Hex (attaching parts)	4
36		• • Washer, Flat (attaching parts)	8
37		• • Washer, SPL Lock (attaching parts)	4
38		• • Nut, Lock (attaching parts)	4
39	78128	• • Valve, Relief	1

DASH (-) ITEM NOT ILLUSTRATED

REVISION:



WATER PUMP CONTROL VALVE ASSEMBLY

01 B70
PARTS
GROUP 80
FIGURE 10
PAGE 01

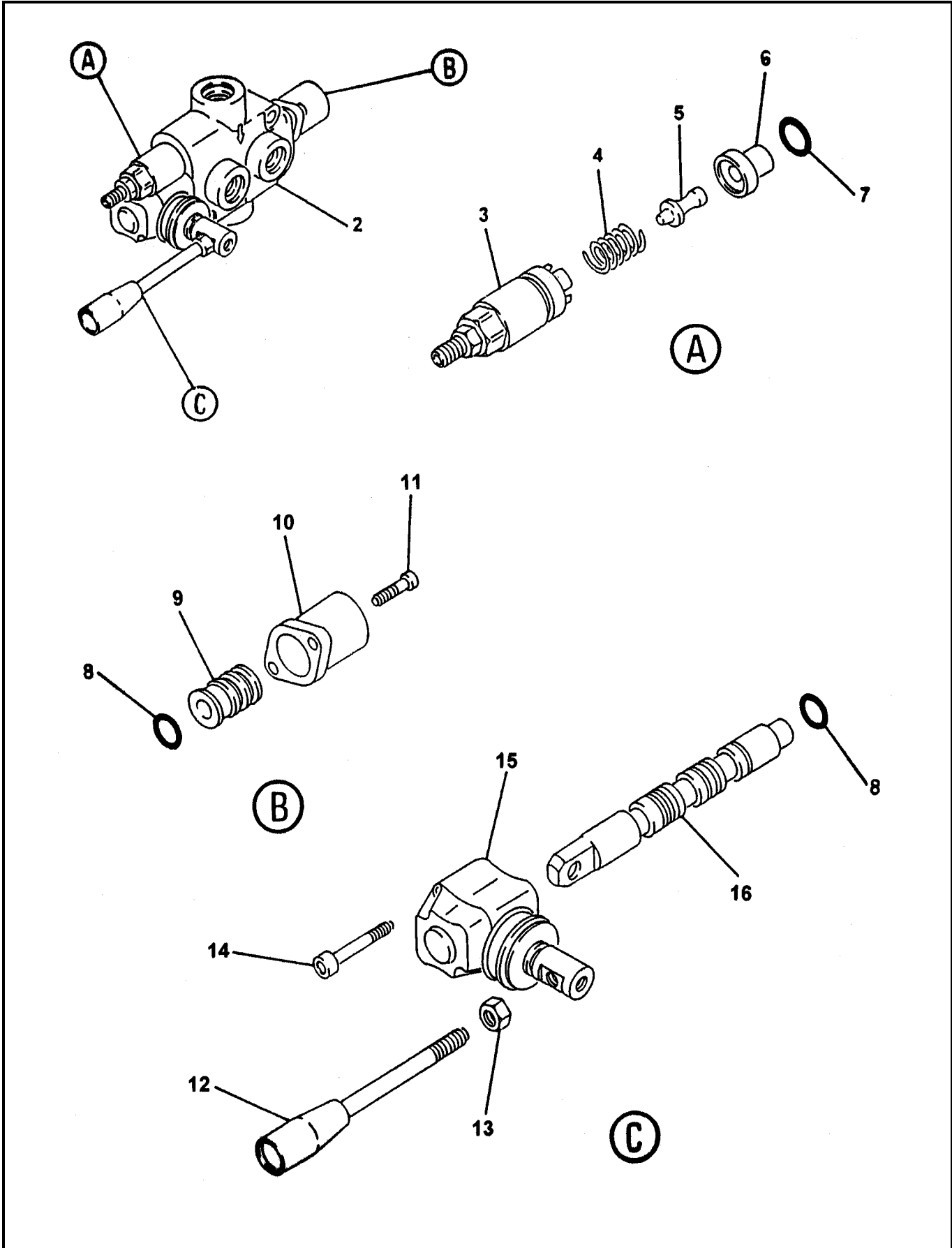

REVISION:



WATER PUMP CONTROL VALVE ASSEMBLY

01 B70
PARTS
GROUP 80
FIGURE 10
PAGE 02

ITEM NO.	REED'S PARTS NO.	DESCRIPTION	QTY
		1 2 3 4 5	
-1	86397	Assembly, Water Pump Control Valve (See Group 80, Figure 09 for NHA)	Ref
2		• Body, Valve	1
3		• Kit, Screw	1
4		• Spring	1
5		• Pin, Screw Kit	1
6		• Ring	1
7		• O-Ring	1
8		• O-Ring	2
9		• Kit, Spool Control	1
10		• Cap, Spool	1
11		• Screw, SOC (attaching Parts)	2
12		• Handle, Remixer Valve	1
13		• Nut (attaching parts)	1
14		• Screw, SOC	2
15		• Lever, L	1
16		• Spool	1

DASH (-) ITEM NOT ILLUSTRATED

REVISION:



WATER PUMP MOTOR ASSEMBLY

01 B70
PARTS
GROUP 80
FIGURE 11
PAGE 01

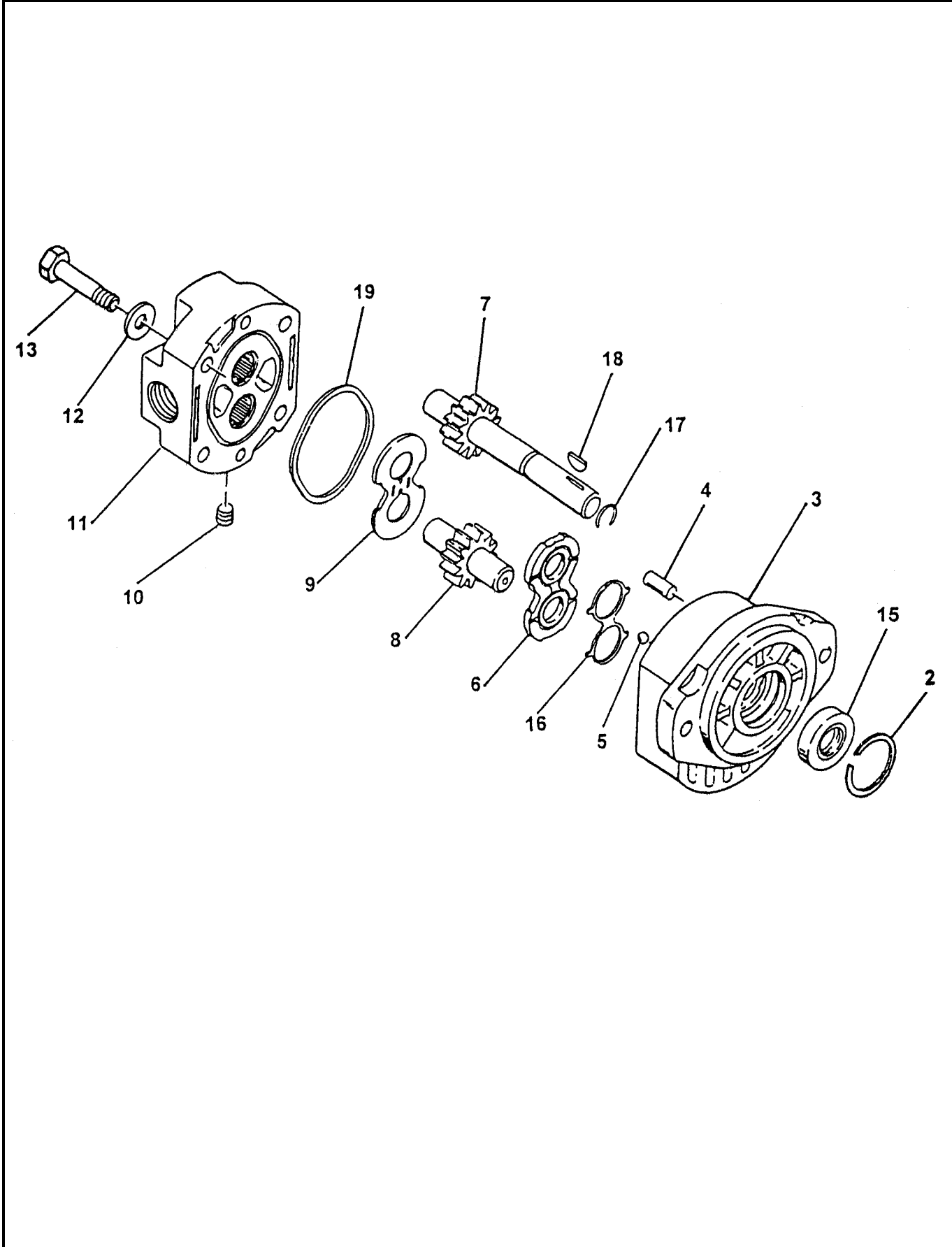

REVISION:



WATER PUMP MOTOR ASSEMBLY

01 B70
PARTS
GROUP 80
FIGURE 11
PAGE 02

ITEM NO.	REED'S PARTS NO.	DESCRIPTION	QTY
		1 2 3 4 5	
-1	78152	Assembly, Wash Pump Motor (See Group 80, Figure 09 for NHA)	Ref
2		• Retainer	1
3		• Assembly, Body	1
4		• Pin, Dowel	2
5		• Bearing, Ball	2
6		• Plate, Wear	1
7		• Gear, Driven Wear	1
8		• Gear, Driven	1
9		• Plate, Thrust	1
10		• Plug, Pipe	4
11		• Assembly, Cover	1
12		• Washer (attaching parts)	4
13		• Screw, Hex (attaching parts)	4
14		• Kit, Seal	1
15		• • Brush	1
16		• • Cap, Brush	1
17		• • Gasket	1
18		• • Cover, Brush	1

DASH (-) ITEM NOT ILLUSTRATED



WATER PUMP ASSEMBLY

01 B70

PARTS

GROUP 80

FIGURE 12

PAGE 01

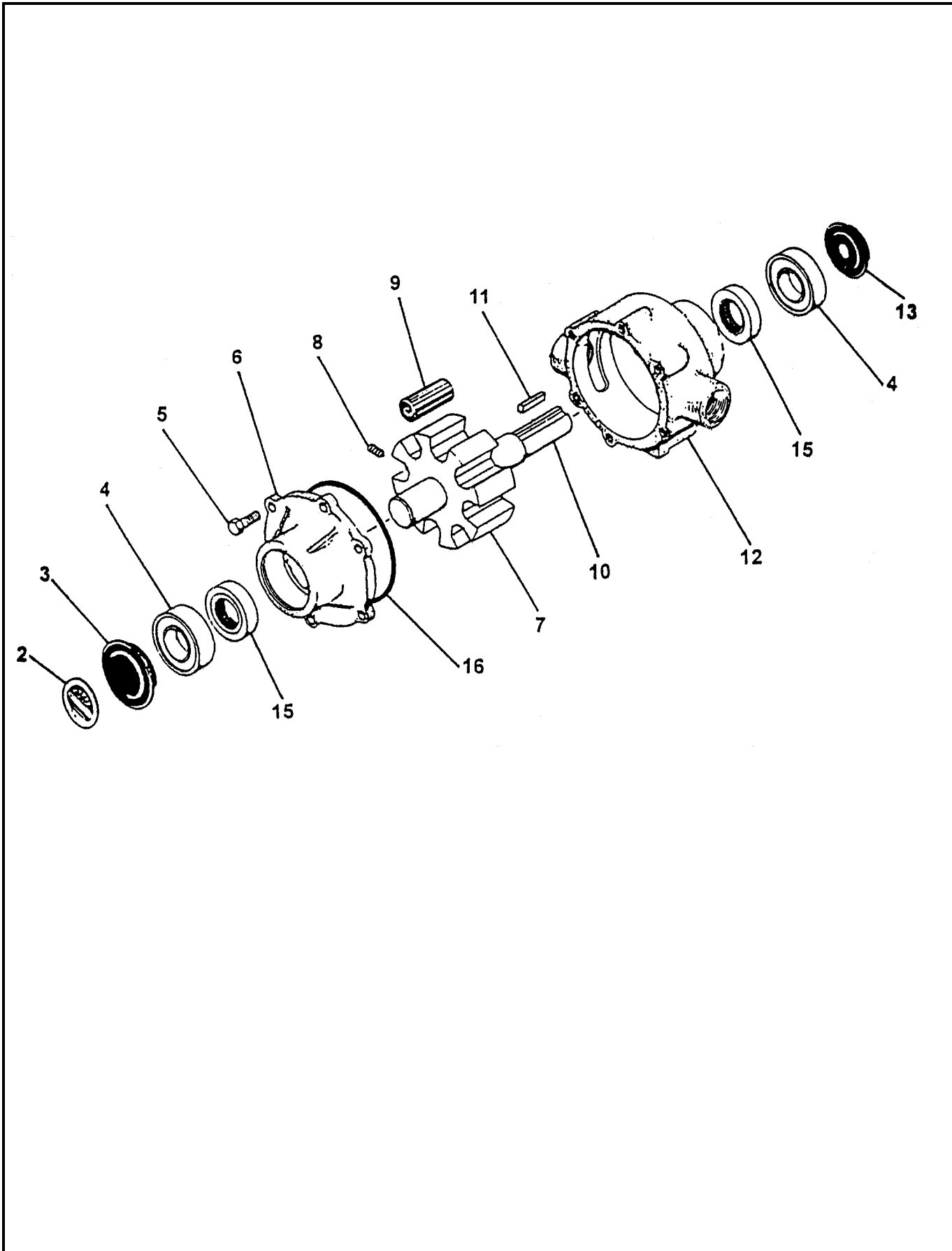

REVISION:



WATER PUMP ASSEMBLY

01 B70
PARTS
GROUP 80
FIGURE 12
PAGE 02

ITEM NO.	REED'S PARTS NO.	DESCRIPTION	QTY
		1 2 3 4 5	
-1	78157	Assembly, Wash Water Pump (See Group 80, Figure 09 for NHA)	Ref
2		• Plate, Name	1
3		• Cover, Bearing Rear	1
4		• Bearing, Sealed Bowl	2
5		• Endplate, (Ni-Resist) with Seal	1
6		• Bolt, Hex (attaching parts)	6
7		• Rotor, (Ni-Resist) with Shaft	1
8		• Screw, Set (attaching parts)	1
9		• Roller, Teflon	1
10		• Shaft	1
11		• Key	1
12		• Body, (Ni-Resist) with Seal	1
13		• Cover, Bearing Shaft	1
-14	72329	• Kit, Seal	1
15		• • Seal, Buna	2
16		• • Gasket, End Plate O-Ring	1

DASH (-) ITEM NOT ILLUSTRATED



NON-OPERATOR SIDE HYDRAULIC BRAKE ASSEMBLY

01 B70
PARTS
GROUP 80
FIGURE 13
PAGE 01

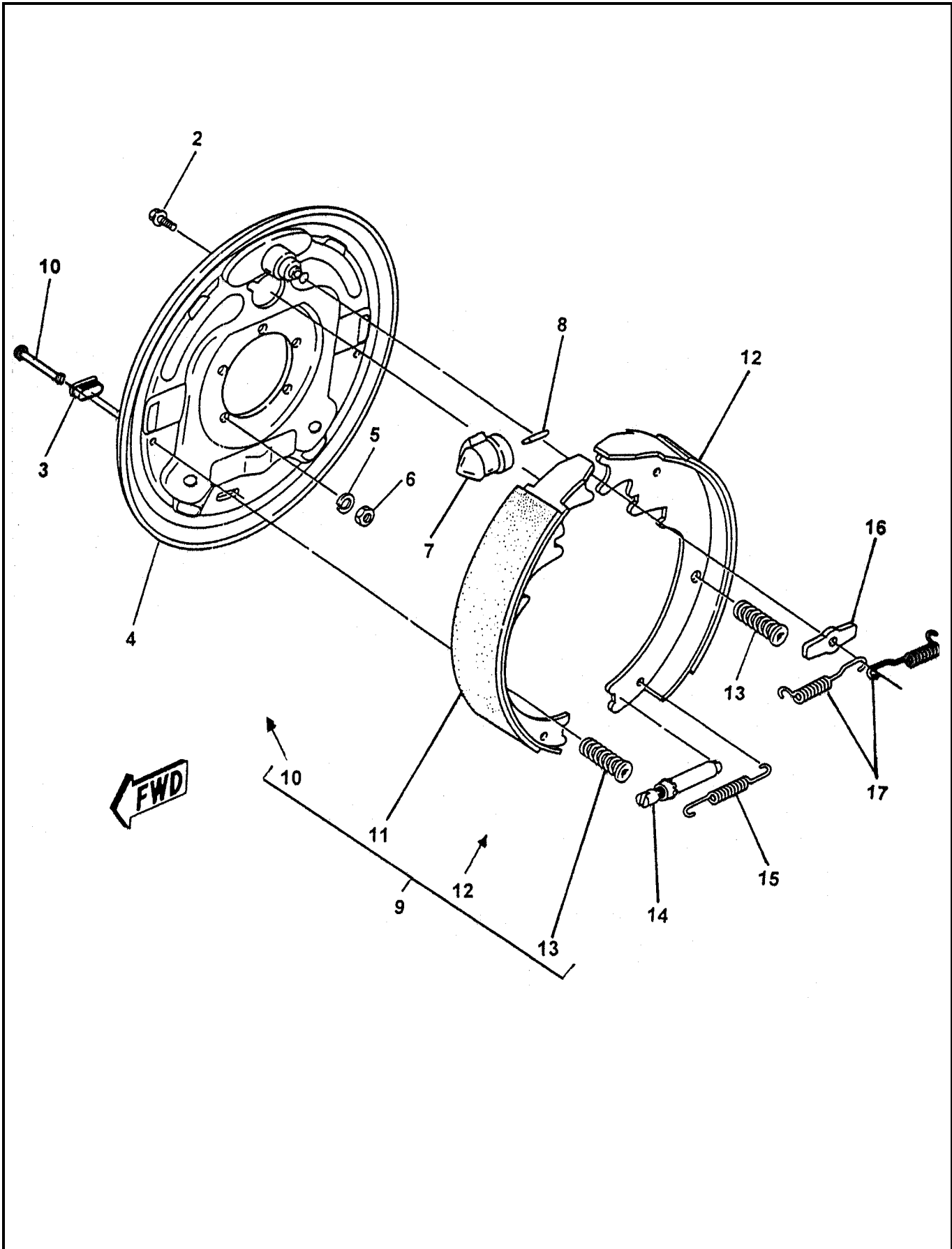

REVISION:



NON-OPERATOR SIDE HYDRAULIC BRAKE ASSEMBLY

01 B70
PARTS
GROUP 80
FIGURE 13
PAGE 02

ITEM NO.	REED'S PARTS NO.	DESCRIPTION	QTY
		1 2 3 4 5	
-1	80-12	Assembly, Non-Operator Side Hydraulic Brake (See Group 80, Figure 01 for NHA)	Ref
2		• Screw, with Washer	1
3		• Plug	2
4		• Plate, Backing	1
5		• Washer, Lock (attaching parts)	5
6		• Nut, Brake Mounting (attaching parts)	5
7		• Cylinder, Non-Operator Side Brake	1
8		• Rod, Push	1
9		• Kit, Non-Operator Side Shoe and Lining	1
10		• • Pin, Shoe Hold Down	2
11		• • Primary, Non-Operator Side	1
12		• • Secondary, Non-Operator Side	1
13		• • Pin, Shoe Hold Down	2
14		• Assembly, Adjuster	1
15		• Spring, Adjusting Screw	1
16		• Washer, Anchor Post	1
17		• Spring, Retractor	2

DASH (-) ITEM NOT ILLUSTRATED

REVISION:



OPERATOR SIDE HYDRAULIC BRAKE ASSEMBLY

01 B70
PARTS
GROUP 80
FIGURE 14
PAGE 01

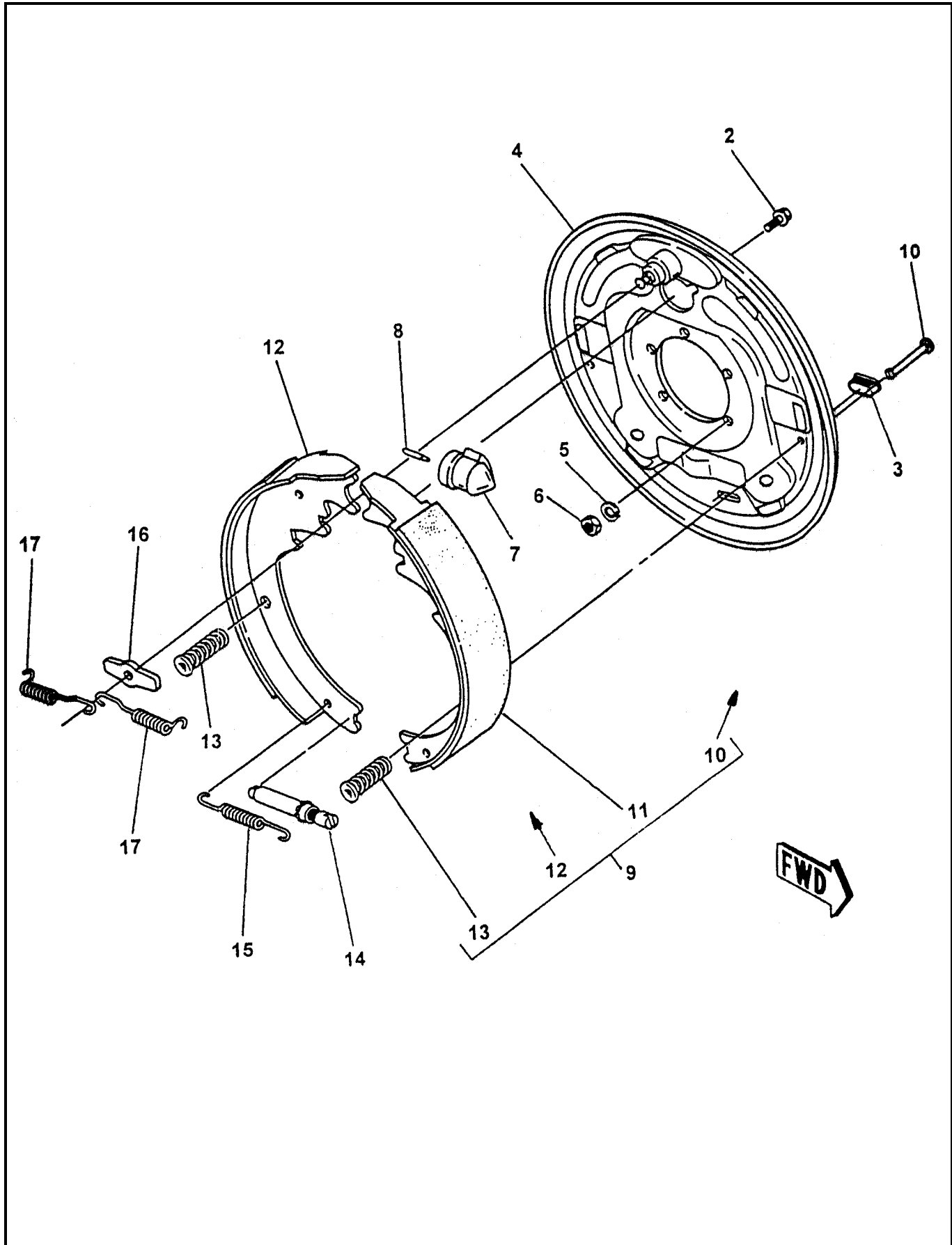

REVISION:



**OPERATOR SIDE
HYDRAULIC BRAKE ASSEMBLY**

**01 B70
PARTS
GROUP 80
FIGURE 14
PAGE 02**

ITEM NO.	REED'S PARTS NO.	DESCRIPTION	QTY
		1 2 3 4 5	
-1	80-13	Assembly, Operator Side Hydraulic Brake (See Group 80, Figure 01 for NHA)	Ref
2		• Screw, with Washer	1
3		• Plug	2
4		• Plate, Backing	1
5		• Washer, Lock (attaching parts)	5
6		• Nut, Brake Mounting (attaching parts)	5
7		• Cylinder, Operator Side Brake	1
8		• Rod, Push	1
9		• Kit, Operator Side Shoe and Lining	1
10		• • Pin, Shoe Hold Down	2
11		• • Primary, Operator Side	1
12		• • Secondary, Operator Side	1
13		• • Pin, Shoe Hold Down	2
14		• Assembly, Adjuster	1
15		• Spring, Adjusting Screw	1
16		• Washer, Anchor Post	1
17		• Spring, Retractor	2

DASH (-) ITEM NOT ILLUSTRATED

REVISION:



HYDRAULIC OUTRIGGER CYLINDER ASSEMBLY

01 B70
PARTS
GROUP 80
FIGURE 15
PAGE 01

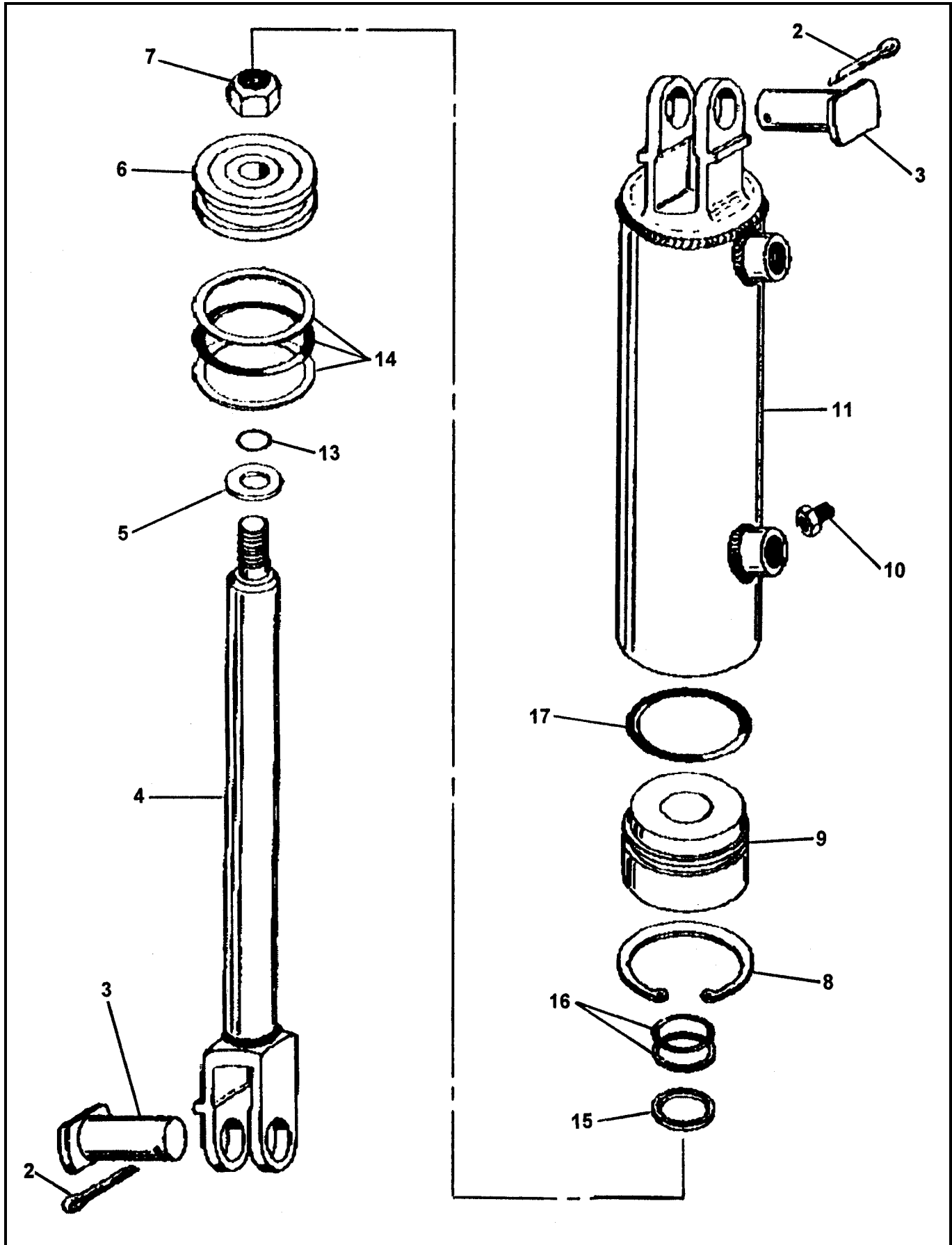

REVISION:



HYDRAULIC OUTRIGGER CYLINDER ASSEMBLY

01 B70

PARTS

GROUP 80

FIGURE 15

PAGE 02

ITEM NO.	REED'S PARTS NO.	DESCRIPTION	QTY
		1 2 3 4 5	
-1	85640	Assembly, Hydraulic Outrigger Cylinder (See Group 80, Figure 01 for NHA)	Ref
2		• Pin, Safety	2
3		• Pin, Clevis	2
4		• Assembly, Shaft	1
5		• Washer, Steel	1
6		• Piston	1
7		• Nut, Piston Lock	1
8		• Ring, Head Lock	1
9		• Head	1
10		• Screw, Head Set	1
11		• Assembly, Tube	1
-12	74497	• Kit, Seal	1
13		• • O-Ring, Small	1
14		• • Sub-Assembly, Piston O-Ring	1
15		• • Wiper, Rod	1
16		• • Packing, Shaft (Pair)	1
17		• • O-Ring, Head	1

DASH (-) ITEM NOT ILLUSTRATED

REVISION:



1 SPOOL CONTROL VALVE ASSEMBLY

01 B70
PARTS
GROUP 80
FIGURE 16
PAGE 01

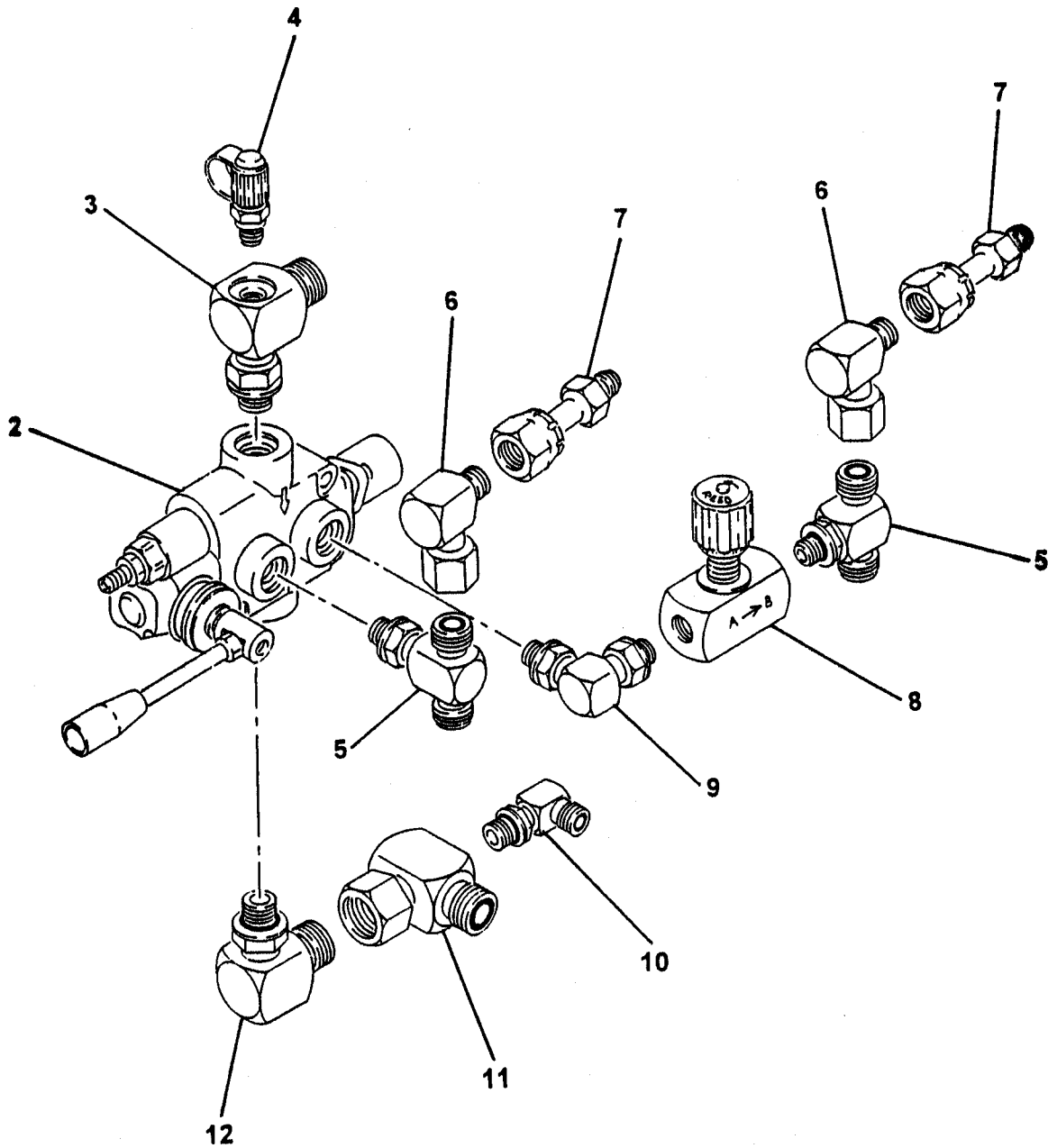

REVISION:



1 SPOOL CONTROL VALVE ASSEMBLY

01 B70

PARTS

GROUP 80

FIGURE 16

PAGE 02

ITEM NO.	REED'S PARTS NO.	DESCRIPTION	QTY
		1 2 3 4 5	
-1	80-16	Assembly, 1 Spool Control Valve (See Group 80, Figure 01 for NHA)	Ref
2	74584	• Sub-Assembly, 1 Spool Control Valve (See Group 80, Figure 17 for DET)	1
3		• Tee, Special Drill	1
4	78593	• Fitting, Mini Check (Port)	1
5		• Tee	2
6		• Fitting, 90	2
7		• Fitting, Connector	2
8		• Controller, Check	1
9		• Fitting, 90	1
10		• Fitting, 90	1
11		• Tee, Special Drill	1
12		• Fitting, 90	1

DASH (-) ITEM NOT ILLUSTRATED

REVISION:



1 SPOOL CONTROL VALVE SUB-ASSEMBLY

01 B70
PARTS
GROUP 80
FIGURE 17
PAGE 01

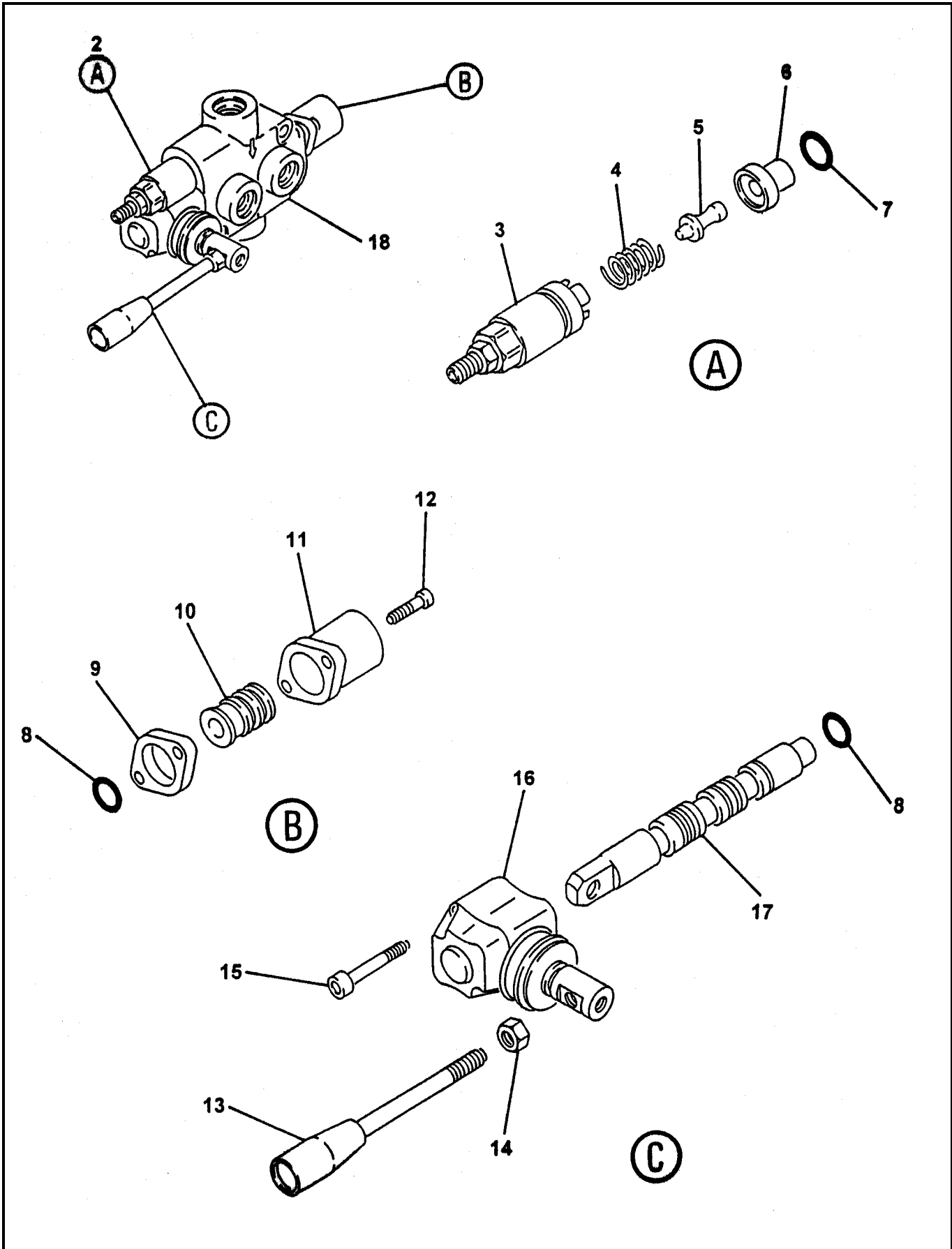

REVISION:



1 SPOOL CONTROL VALVE SUB-ASSEMBLY

01 B70
PARTS
GROUP 80
FIGURE 17
PAGE 02

ITEM NO.	REED'S PARTS NO.	DESCRIPTION	QTY
		1 2 3 4 5	
-1	74584	Sub-Assembly, 1 Spool Control Valve (See Group 80, Figure 16 for NHA)	Ref
2	85706	• Cartridge, Relief	1
3		• • Kit, Screw	1
4		• • Spring	1
5		• • Pin, Screw Kit	1
6		• • Ring	1
7		• • O-Ring	1
8		• O-Ring	2
9		• Spacer	1
10		• Kit, Spool Control	1
11		• Cap, Spool	1
12		• Screw, SOC (attaching Parts)	2
13		• Handle, Remixer Valve	1
14		• Nut (attaching parts)	1
15		• Screw, SOC	2
16		• Lever, L	1
17		• Spool	1
18		• Body, Valve	1

DASH (-) ITEM NOT ILLUSTRATED

REVISION:



2 SPOOL CONTROL VALVE ASSEMBLY

01 B70
PARTS
GROUP 80
FIGURE 18
PAGE 01

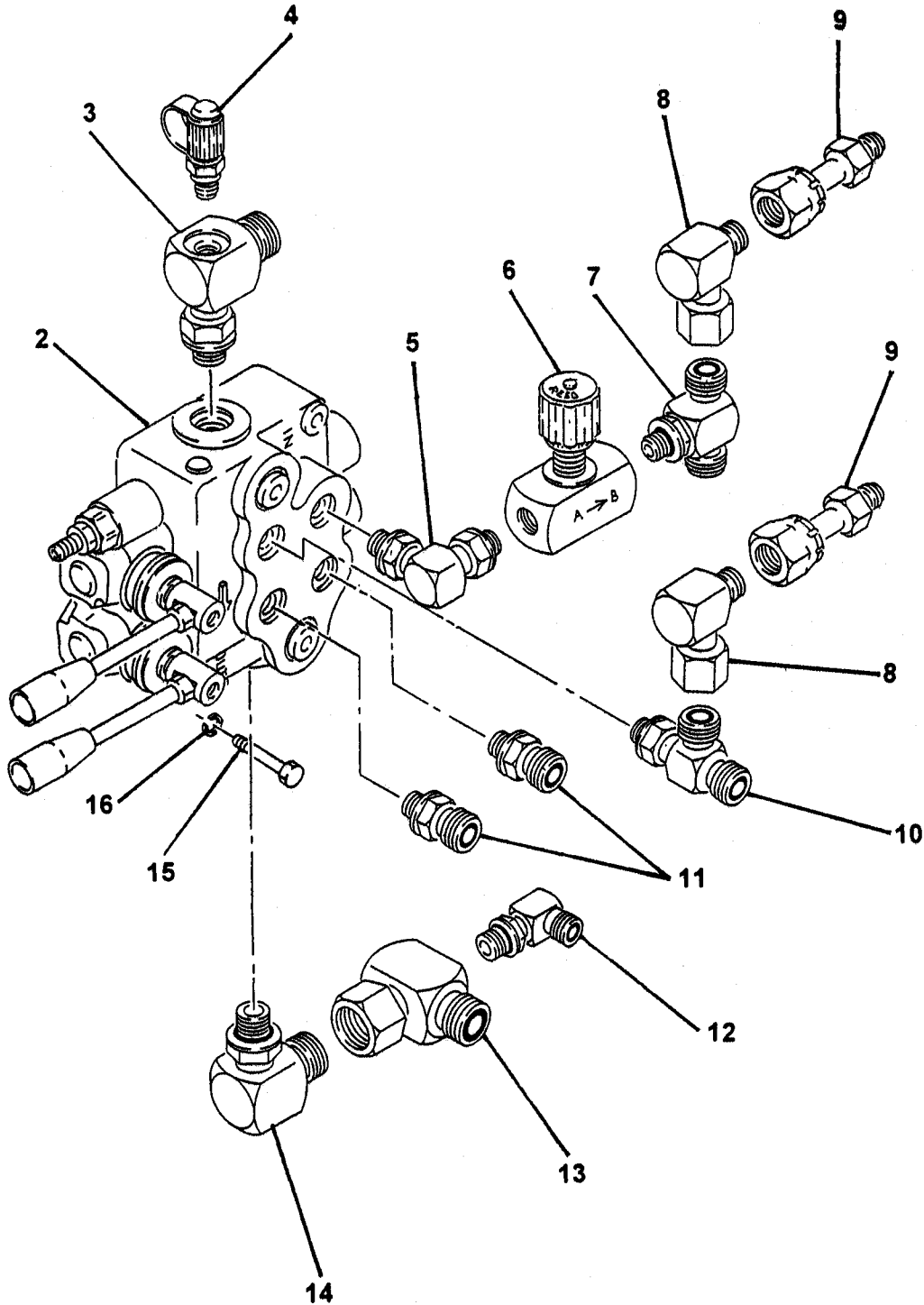

REVISION:



2 SPOOL CONTROL VALVE ASSEMBLY

01 B70
PARTS
GROUP 80
FIGURE 18
PAGE 02

ITEM NO.	REED'S PARTS NO.	DESCRIPTION	QTY
		1 2 3 4 5	
-1	80-18	Assembly, 2 Spool Control Valve (See Group 80, Figure 01 for NHA)	Ref
2	74585	• Sub-Assembly, 2 Spool Control Valve (See Group 80, Figure 20 for DET)	1
3		• Tee, Special Drill	1
4	78593	• Fitting, Mini Check (Port)	1
5		• Fitting, 90	1
6		• Controller, Check	1
7		• Tee	1
8		• Fitting	2
9		• Fitting, Connector	2
10		• Tee	1
11		• Fitting, 90	2
12		• Fitting, 90	1
13		• Tee, Special Drill	1
14		• Fitting, 90	1
15		• Bolt, Hex	2
16		• Washer, SPL Lock	2

DASH (-) ITEM NOT ILLUSTRATED

REVISION:



2 SPOOL CONTROL VALVE SUB-ASSEMBLY

01 B70
PARTS
GROUP 80
FIGURE 19
PAGE 01

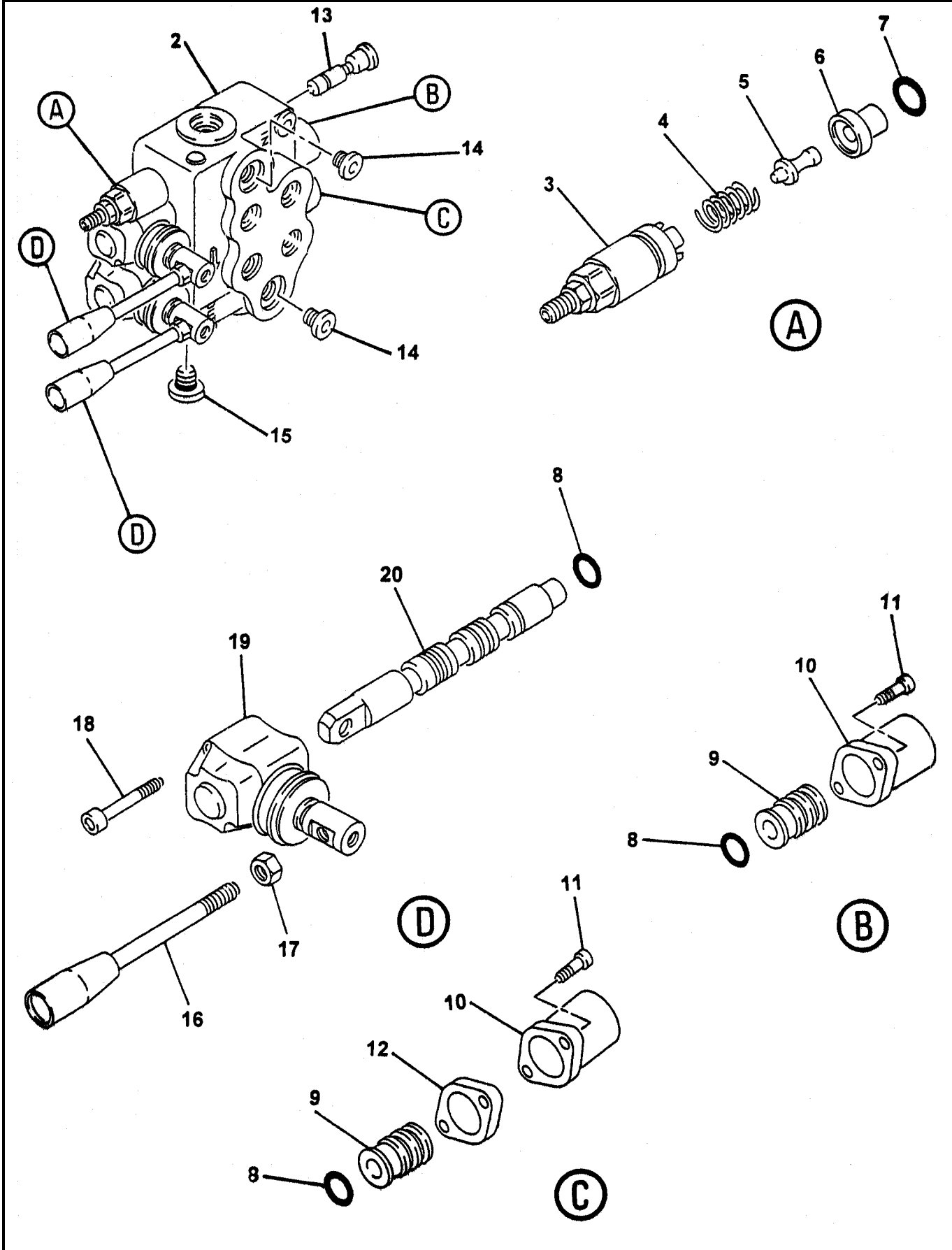

REVISION:



2 SPOOL CONTROL VALVE SUB-ASSEMBLY

01 B70

PARTS

GROUP 80

FIGURE 19

PAGE 02

ITEM NO.	REED'S PARTS NO.	DESCRIPTION	QTY
		1 2 3 4 5	
-1	74585	Sub-Assembly, 2 Spool Control Valve (See Group 80, Figure 18 for NHA)	Ref
2	85706	• Cartridge, Relief	1
3		• • Kit, Screw	1
4		• • Spring	1
5		• • Pin, Screw Kit	1
6		• • Ring	1
7		• • O-Ring	1
8		• O-Ring	4
9		• Kit, Spool Control	2
10		• Cap, Spool	2
11		• Screw, SOC (attaching Parts)	4
12		• Spacer	1
13		• Kit, VRS	1
14		• Plug	2
15		• Plug	1
16		• Handle, Remixer Valve	2
17		• Nut (attaching parts)	2
18		• Screw, SOC	4
19		• Lever, L	2
20		• Spool	2
21		• Body, Valve	1

DASH (-) ITEM NOT ILLUSTRATED

REVISION:



SIDE DOOR ASSEMBLY

01 B70

PARTS

GROUP 80

FIGURE 20

PAGE 01

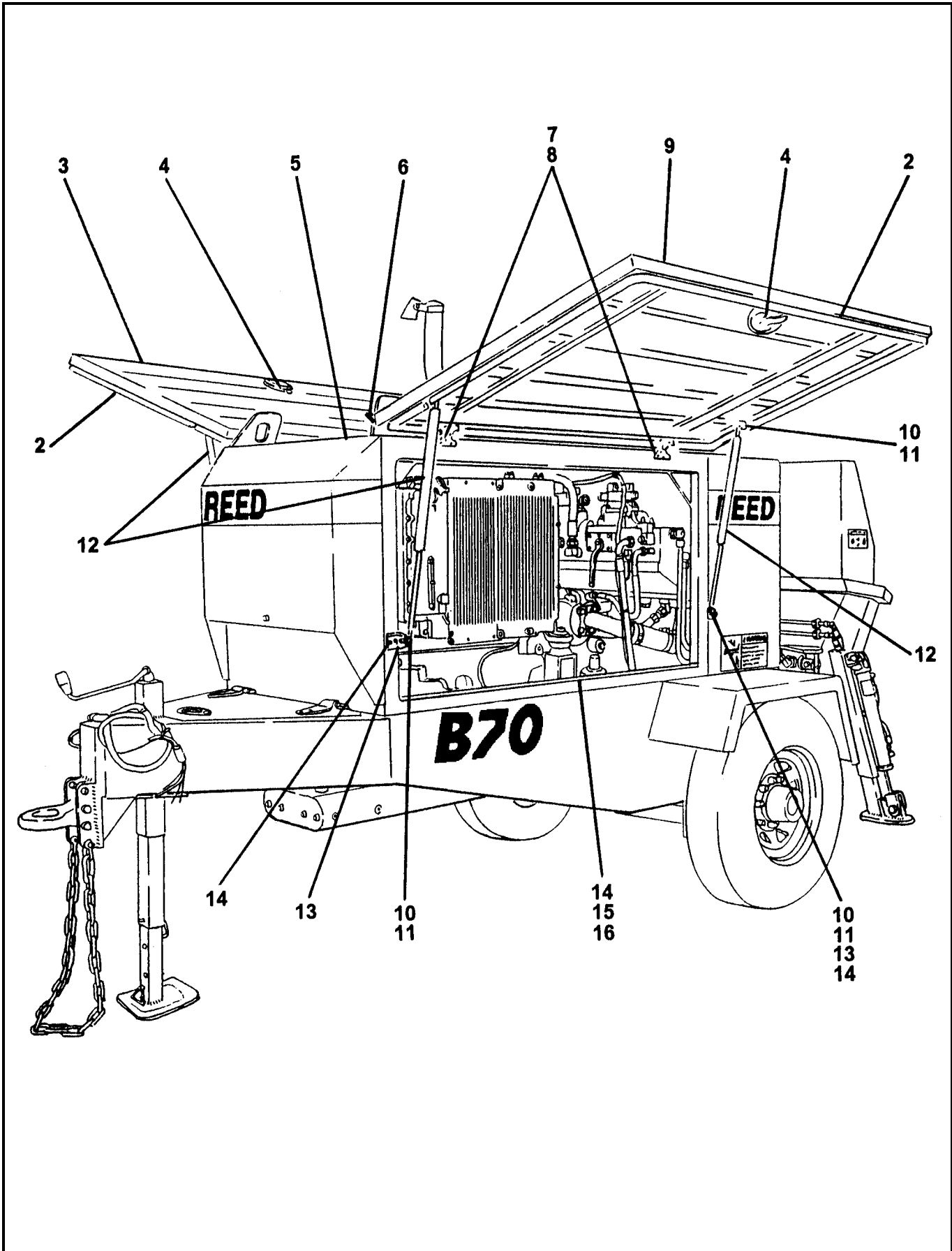

REVISION:



SIDE DOOR ASSEMBLY

01 B70

PARTS

GROUP 80

FIGURE 20

PAGE 02

ITEM NO.	REED'S PARTS NO.	DESCRIPTION	QTY
		1 2 3 4 5	
-1	85943	Assembly, B-Series Side Door (See Group 80, Figure 01 for NHA)	Ref
2	73163	• Seal, 3/8 Bulb 15.75 FT Trim	A/R
3	85968	• Weldment, B-Series Right Hand Side Door	1
4	73767	• Latch, D Ring with Key	2
5	86144	• Structure, Lifting	1
6	71364	• Seal, 3/8 Bulb 3.5 FT Trim	A/R
7	85928	• Hinge, Machining	4
8	85945	• Screw, Button Head Cap	12
9	85967	• Weldment, B-Series Left Hand Side Door	1
10	75215	• Stud, Ball	8
11		• Washer, Flat	A/R
12	75214	• Spring, 130 LBS Gas	4
13	85931	• Tab, Frame Gas Spring	2
14	85944	• Screw, Button Head Cap	16
15	85939	• Angle, Left Hand Side Door	1
16	85940	• Angle, Right Hand Side Door	1

DASH (-) ITEM NOT ILLUSTRATED

REVISION:



50 FEET STROKE COUNTER CABLE REMOTE CONTROL ASSEMBLY

01 B70
PARTS
GROUP 80
FIGURE 21
PAGE 01

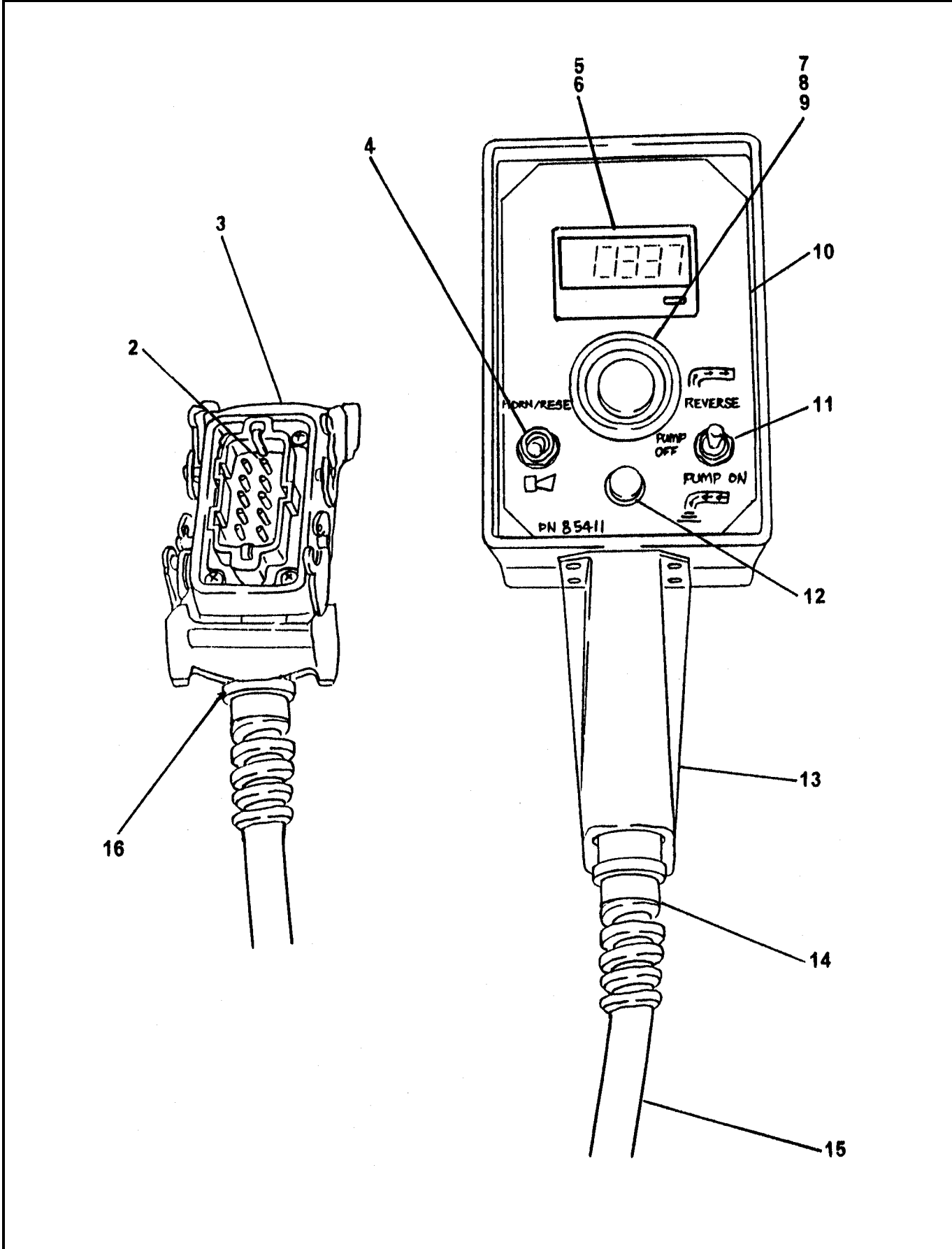

REVISION:



50 FEET STROKE COUNTER CABLE REMOTE CONTROL ASSEMBLY

01 B70
PARTS
GROUP 80
FIGURE 21
PAGE 02

ITEM NO.	REED'S PARTS NO.	DESCRIPTION	QTY
		1 2 3 4 5	
-1	85960	Assembly, 50 Feet Cable Remote Control with Stroke Counter (See Group 80, Figure 01 for NHA)	Ref
2	79964	• Connector, Insert	1
3	79966	• Connector, Hood	1
4	85347	• Switch, Horn / Reset	1
5	72330	• Counter, Stroke	1
6	74388	• Diode, Stroke Counter	1
7	85342	• Operator, Emergency Stop	1
8	85343	• Block, 1 NC Lighted Contact	1
9	85344	• Bulb, Emergency Stop	1
10	85411	• Decal, C-Series Remote Control Box	1
11	72003	• Switch, Pump On / Reverse	1
12	85355	• Pilot, Light	1
13	85961	• Enclosure, Remote Control	1
14	86133	• Relief, PG-11 Spiral Strain	1
15	85620	• Cable, 50 Feet Remote Control	1
16	86145	• Reducer, PG-16 to PG-11	1
-17	72777	• Resister, Green 100 OHM	1

DASH (-) ITEM NOT ILLUSTRATED



100 FEET STROKE COUNTER CABLE REMOTE CONTROL ASSEMBLY

01 B70
PARTS
GROUP 80
FIGURE 22
PAGE 01

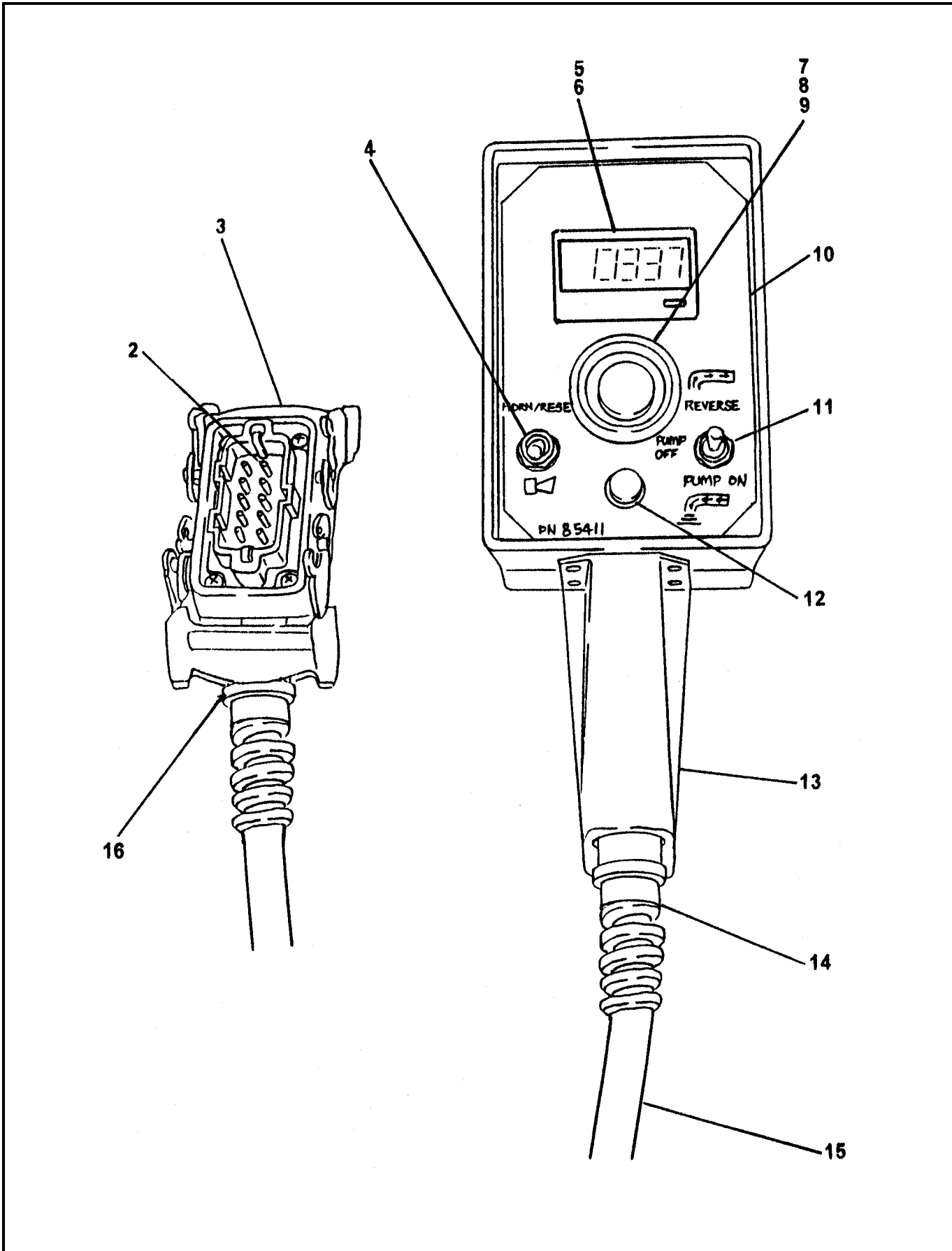

REVISION:



**100 FEET STROKE COUNTER
CABLE REMOTE CONTROL ASSEMBLY**

01 B70
PARTS
GROUP 80
FIGURE 22
PAGE 02

ITEM NO.	REED'S PARTS NO.	DESCRIPTION	QTY
		1 2 3 4 5	
-1	85960A	Assembly, 100 Feet Cable Remote Control with Stroke Counter (See Group 80, Figure 01 for NHA)	Ref
2	79964	• Connector, Insert	1
3	79966	• Connector, Hood	1
4	85347	• Switch, Horn / Reset	1
5	72330	• Counter, Stroke	1
6	74388	• Diode, Stroke Counter	1
7	85342	• Operator, Emergency Stop	1
8	85343	• Block, 1 NC Lighted Contact	1
9	85344	• Bulb, Emergency Stop	1
10	85411	• Decal, C-Series Remote Control Box	1
11	72003	• Switch, Pump On / Reverse	1
12	85355	• Pilot, Light	1
13	85961	• Enclosure, Remote Control	1
14	86133	• Relief, PG-11 Spiral Strain	1
15	85816	• Cable, 100 Feet Remote Control	1
16	86145	• Reducer, PG-16 to PG-11	1
-17	72777	• Resister, Green 100 OHM	1

DASH (-) ITEM NOT ILLUSTRATED