



TRAILER MOUNTED PUMP MODEL B50 DRIVE CYLINDER CIRCUIT HYDRAULIC COMPONENTS & SCHEMATIC

B SERIES DRIVE CYLINDER CIRCUIT
HYDRAULIC SCHEMATIC

DATE
12/3/01

REV.

PART NO.
86708

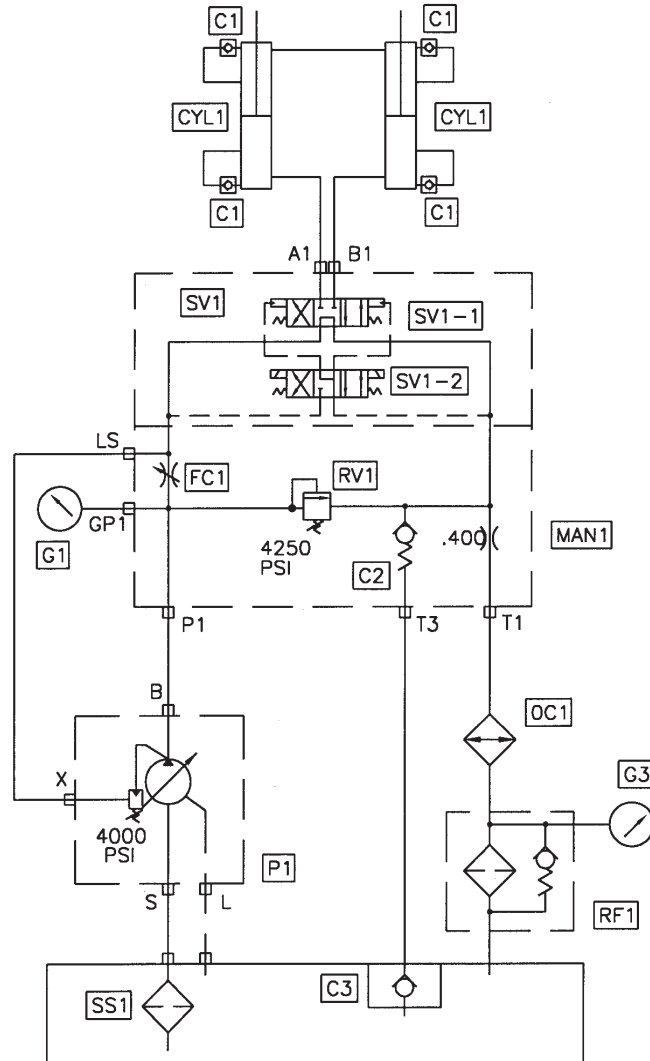

CODE	DESCRIPTION	PART NO.	QTY.
P1	Main Pump, Parts, Group 40		
CYL1	Hydraulic Drive Cylinder, Parts Group 60		
MAN1	Manifold Drive Cylinder Circuit	85248	1
SV1	Solenoid Valve, Drive Cylinder Circuit	85689	1
SV1-1	Solenoid Valve Main	85690	1
SV2-2	Solenoid Valve Pilot	85691	1
	Coil For SV2-2	85692	2
RV1	Relief Valve Cartridge	85696	1
FC1	Flow Control Valve Cartridge	85697	1
C1	Check Valve	78961	4
C2	Check Valve Cartridge	85698	1
C3	Check Valve	85574	1
G1	Pressure Gauge 6000 psi	74562	1
G3	Pressure Gauge Return	85575	1
OC1	Oil Cooler	85713	1
RF1	Return Filter	85282	1
	Return Filter Element	85283	1
SS1	Magnetic Suction Strainer 2"	801024	1

B & C SERIES SWING TUBE HYDRAULIC
SCHEMATIC, SINGLE SHIFT CYLINDER

DATE
11/7/01

REV.

PART NO.
86705

REED

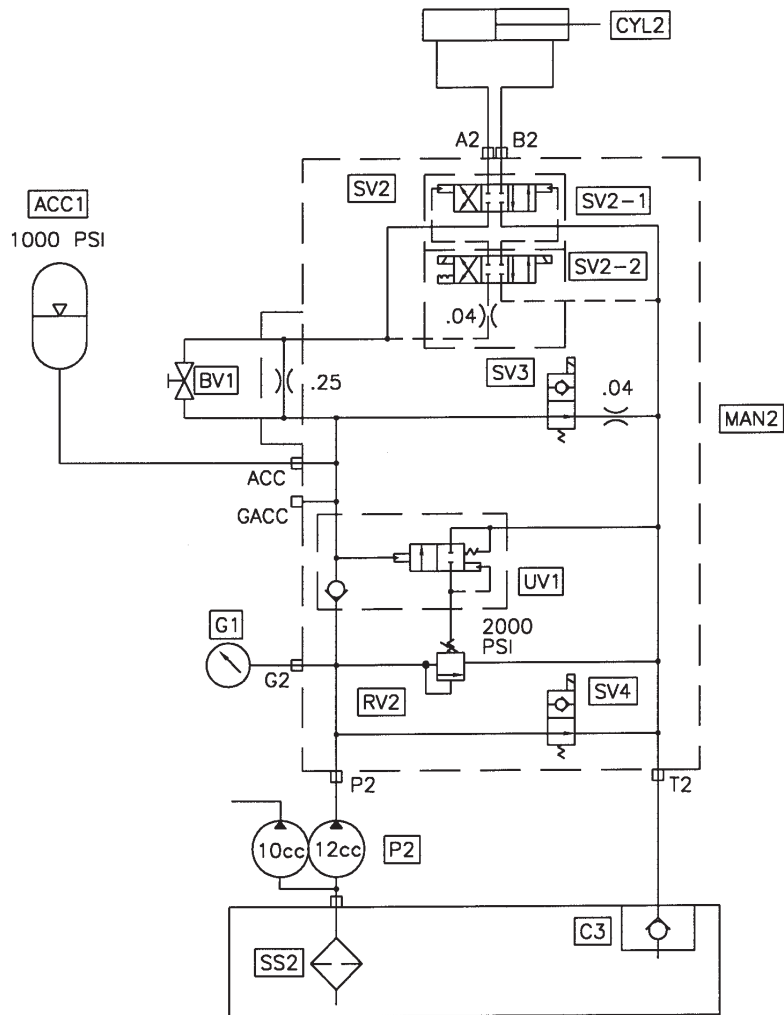

CODE	DESCRIPTION	PART NO.	QTY.
P2	Gear Pump, Parts, Group 40	73156	1
CYL2	S Tube Single Shift Cylinder	86221	1
MAN2	Manifold S Tube Circuit	85249	1
SV2	Solenoid Valve S Tube Circuit	85693	1
SV2-1	Solenoid Valve Main	85694	1
SV2-2	Solenoid Valve Pilot	85695	1
	Coil For SV2-2	85692	2
SV3	Solenoid Valve Cartridge	85699	1
	Coil For SV3	85700	1
SV4	Solenoid Valve Cartridge	85701	1
	Coil For SV4	85702	1
RV2	Relife Valve Cartrige	85703	1
UN1	Unlodng Valve Cartrige	85704	1
BV1	Ball Valve	85705	1
AAC1	Accumulator	74515	1
	Accumulator, Bladder	74516	1
G2	Pressure Gauge 3000 PSI	70366	1
SS2	Magnetic Suction Strainer 1 1/4"	79247	1
C3	Check Valve	85574	1



**TRAILER MOUNTED PUMP MODEL B50
DUAL SHIFT SWING TUBE CIRCUIT
HYDRAULIC COMPONENTS & SCHEMATIC**

B & C SERIES SWING TUBE HYDRAULIC SCHEMATIC, DUAL SHIFT CYLINDER

DATE
11/7/01

REV.
PART NO.
86706

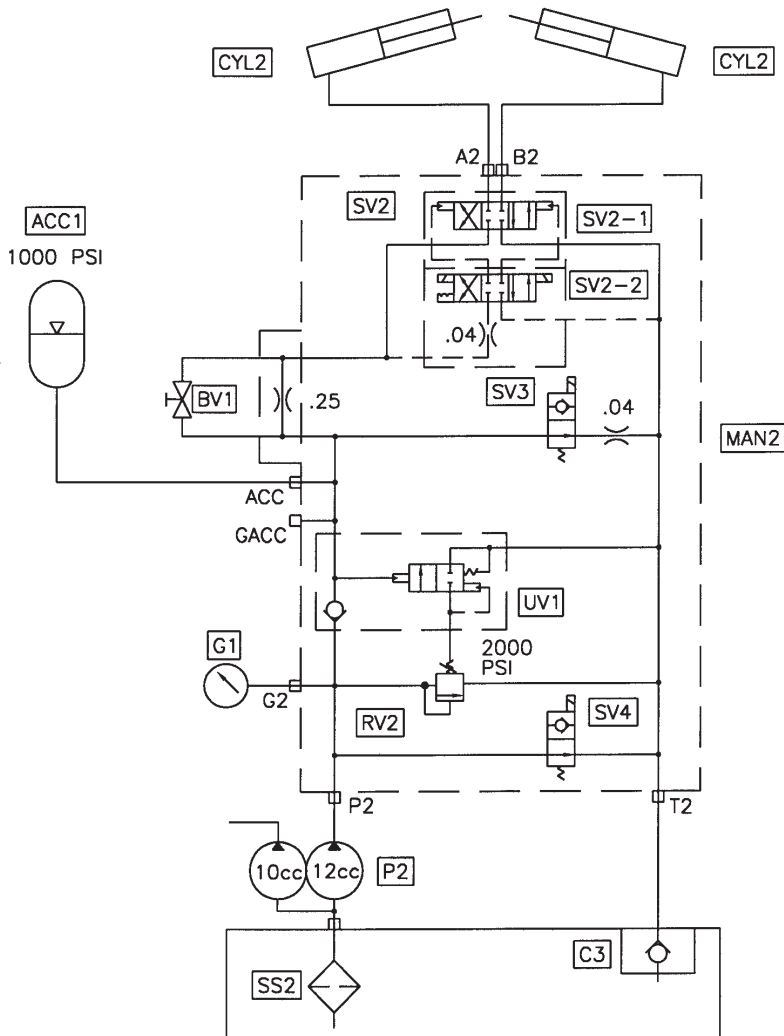

CODE	DESCRIPTION	PART NO.	QTY.
P2	Gear Pump, Parts, Group 40		
CYL2	S Tube Single Shift Cylinder	86220	2
MAN2	Manifold S Tube Circuit	85249	1
SV2	Solenoid Valve S Tube Circuit	85693	1
SV2-1	Solenoid Valve Main	85694	1
SV2-2	Solenoid Valve Pilot	85695	1
	Coil For SV2-2	85692	2
SV3	Solenoid Valve Cartridge	85699	1
	Coil For SV3	85700	1
SV4	Solenoid Valve Cartridge	85701	1
	Coil For SV4	85702	1
RV2	Relife Valve Cartrige	85703	1
UN1	Unlodng Valve Cartrige	85704	1
BV1	Ball Valve	85705	1
AAC1	Accumulator	74515	1
	Accumulator, Bladder	74516	1
G2	Pressure Gauge 3000 PSI	70366	1
SS2	Magnetic Suction Strainer 1 1/4"	79247	1
C3	Check Valve	85574	1

REVISION:



**TRAILER MOUNTED PUMP
MODEL B50
HYDRAULIC HOSE KIT**

HOSE KIT 86365

Part No.	End #1	End #2
85666-001	Main Pump "P"	Cylinder Manifold "P1"
85666-001	Cylinder Bulkhead "A"	Cylinder "A"
85666-006	Cylinder Bulkhead "B"	Cylinder "B"
85659-001	Main Pump Load Sense	Cylinder Manifold "LS"
85657-005	Main Pump Case Drain	Tank Return
85654-001	Cylinder Manifold "T1"	Oil Cooler "IN"
85654-001	Oil Cooler "OUT"	Return Filter Bulkhead
85659-002	Check Loop	
85659-002	Check Loop	
85659-002	Check Loop	
85659-002	Check Loop	
85659-002	Check Loop	
85663-002	Tank Suction	Tandem Pump "S"
85657-002	Tandem Pump 12cc "P"	S-Tube Manifold "P2"
85667-001	S-Tube Manifold "ACC"	Accumulator
85657-002	Bulkhead "A"	Left Shift Cylinder Bore Side
85657-002	Bulkhead "B"	Right Shift Cylinder Bore Side
85657-003	Tandem Pump 10cc "P"	Bulkhead Tee "P"
85657-002	Bulkhead Tee "P"	Bypass Valve "1"
85657-016	Bulkhead "T"	Bulkhead "P"
85657-004	Bulkhead "T"	Cylinder Manifold "T1"

SUCTION HOSES - POWER TRAIN

Part No.	End #1	End #2
85660-001	Tank Suction	Main Pump "S"
85661-001	Tank Suction	Main Pump "S"
85662-001	Tank Suction	Main Pump "S"

FUEL HOSES - 86344 FUEL GROUP

Part No.	End #1	End #2
85669-001	Fuel Tank Suction	Fuel Filter "IN"
85669-005	Fuel Filter "OUT"	Engine
74716	Engine	Fuel Tank Return

CONTROL VALVE GROUP - 86329

Part No.	End #1	End #2
85657-016	Bulkhead "P"	Agitator Valve "P"
85658-011	Agitator Valve "A"	Agitator Valve "A"
85658-010	Agitator Valve "B"	Agitator Valve "B"

HYD OUTRIGGER GROUP - 86334

Part No.	End #1	End #2
85659-010	O/R Valve "A"	RH Outrigger Bore
85659-010	O/R Valve "B"	RH Outrigger Rod
85659-010	O/R Valve Tube "A"	LH Outrigger Bore
85659-010	O/R Valve Tube "B"	LH Outrigger Rod

WATER PUMP - 86400

Part No.	End #1	End #2
85657-021	Agitator Valve "PB"	Bulkhead "P"
85657-023	Bulkhead "P"	Water Valve "P"
85657-023	Water Valve "T"	Tank
85658-002	Water Valve "B"	Motor "A"
85658-002	Water Valve "A"	Motor "B"
85657-022	Water Relief	Water Suction

REVISION:



**TRAILER MOUNTED PUMP
MODEL B50
ELECTRICAL COMPONENTS (1 OF 2)**

Code	Description	Part No.	Qty.	Location
SWITCHES				
1S1	Key Switch	71154	1	Control Panel
2S2	Toggle Switch, Horn	85347	1	Control Panel
3S3	Toggle Switch, Local/Remote	78563	1	Control Panel
3S4	Toggle Switch, Pump On/Reverse	72003	1	Control Panel
3S5	Toggle Switch, Test A/B	85346	1	Control Panel
3S6	E-Stop Switch	85342	1	Control Panel
	Contact Block, 1NC for 3S6	85343	1	Control Panel
3S7	E-Stop Switch	85342	1	Remote Control
	Contact Block, 1NC for 3S7	85343	1	Remote Control
3S8	Toggle Switch, Horn	85347	1	Remote Control
3S9	Toggle Switch, Pump On/Reverse	72003	1	Remote Control
RELAYS				
1K1	Relay, Engine Start	85348	1	Engine
LIGHTS				
1L1	Light, Green, Control On	85355	1	Control Panel
1L2	Light, Red, Oil Temperature	73775	1	Control Panel
1L3	Light, Red, Coolant Temperature	73775	1	Control Panel
1L4	Light, Red, Oil Pressure	73775	1	Control Panel
1L5	Light, Red, Alternator	73775	1	Control Panel
	Bulb for 1L2, 1L3, 1L4, 1L5	72022	4	Control Panel
2L6	Bulb, E-Stop	85344	1	Control Panel
2L7	Light, Green, Local	85355	1	Control Panel
3L8	Light, Yellow, Remote	85356	1	Control Panel
3L9	Light, Green, Pump On	85355	1	Control Panel
3L10	Light, Green, Reverse	85355	1	Control Panel
3L11	Bulb, E-Stop	85344	1	Remote Control
3L12	Light, Green, Pump On	85355	1	Remote Control
GAUGES				
1G1	Hour Meter	74240	1	Control Panel
1G2	Tachometer	78687	1	Control Panel
1G3	Coolant Temperature Gauge	78203	1	Control Panel



**TRAILER MOUNTED PUMP
MODEL B50
ELECTRICAL COMPONENTS (2 OF 2)**

Code	Description	Part No.	Qty.	Location
FUSES				
1F1	Fuse, 25A	800447	1	Control Panel
1F2	Fuse, 20A	800448	1	Control Panel
1F3	Fuse, 5A	90392	1	Control Panel
2F4	Fuse, 10A	800449	1	Control Panel
2F5	Fuse, 10A	800449	1	Control Panel
2F6	Fuse, 5A	90392	1	Control Panel
2F7	Fuse, 5A	90392	1	Control Panel
2F8	Fuse, 10A	800449	1	Control Panel
	Fuse Block, 8 Way	85354	1	Control Panel
SOLENOID VALVE COILS				
1Y1	Coil, Fuel Solenoid	Deutz	1	Engine
1Y2	Coil, Accumulator Bypass	85700	1	S-Tube Manifold
1Y3	Coil, S-Tube Bypass	85702	1	S-Tube Manifold
1Y4	Coil, Agitator Bypass	73184	1	Hyd. Tank
2Y5	Coil, Cylinder "B"	85692	1	S-Tube Manifold
2Y6	Coil, Cylinder "A"	85692	1	S-Tube Manifold
2Y7	Coil, S-Tube Shift "A"	85692	1	Pump Manifold
2Y8	Coil, S-Tube Shift "B"	85692	1	Pump Manifold
	Plugs for 1Y2 thru 2Y8	74597	7	Manifolds
MISCELLANEOUS				
2BB1	Black Box, Pump Control	85334	1	Control Box
2BB2	Black Box, E-Stop Logic	85596	1	Control Box
2P1	Proximity Switch, Cyl "B"	77998	1	Water Box
2P2	Proximity Switch, Cyl "A"	77998	1	Water Box
2H1	Horn	800347	1	Control Box
3R1	Resistor, 100 Ohm	72777	1	Remote Control
CONNECTORS				
X1	Connector Insert, 24 Pin, Female	78696	1	Control Box
X1	Connector Base	78697	1	Control Box
X1	Connector Insert, 24 Pin, Male	78695	1	Harness
X1	Connector Hood	800424	1	Harness
X2	Terminal Block	72820	8	Control Box
X3	Connector Insert, 10 Pin, Female	79963	1	Control Box
X3	Connector Base	79965	1	Control Box
X3	Connector Insert, 10 Pin, Male	79964	1	Remote Control

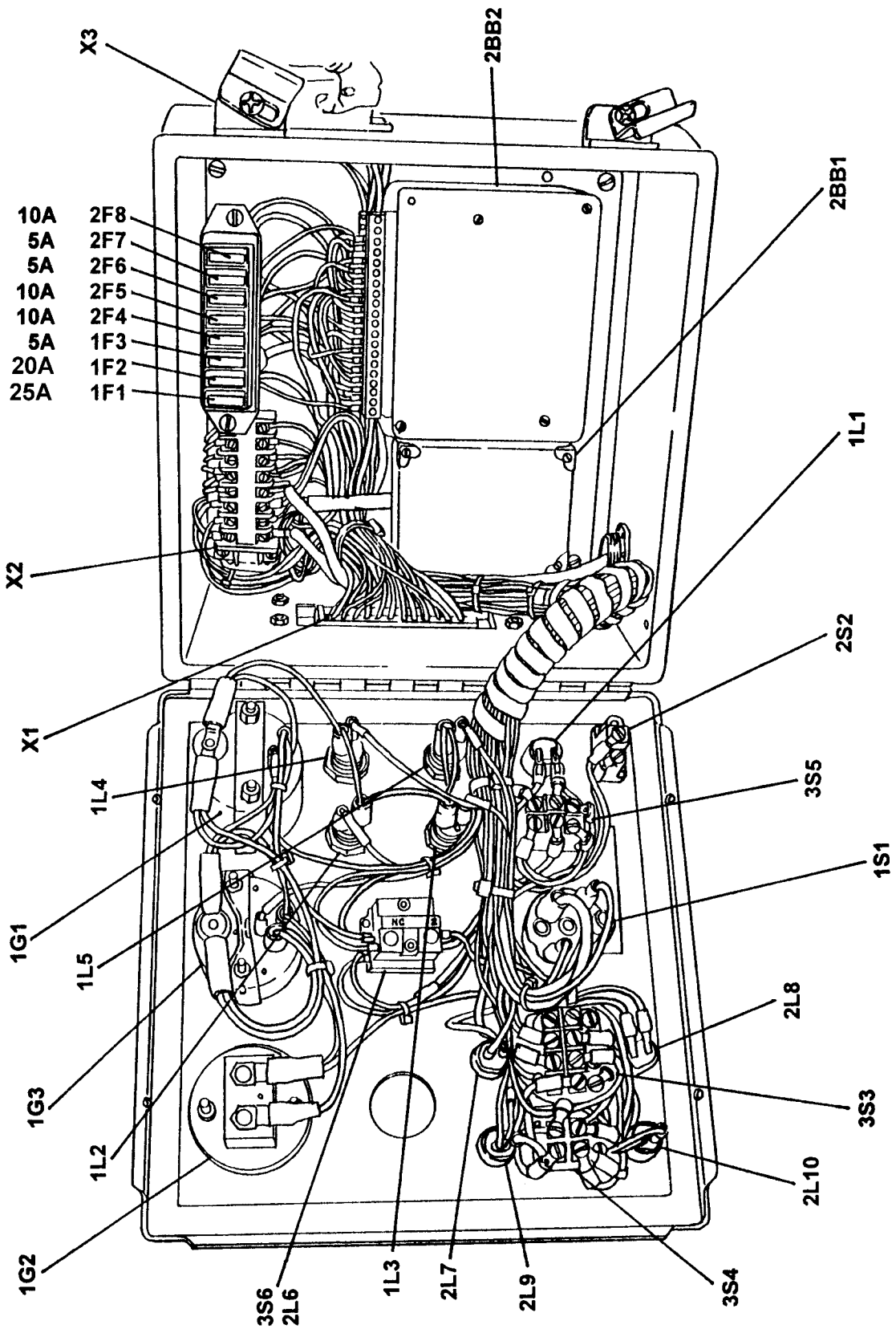



TRAILER MOUNTED PUMP MODEL B50
CABLE REMOTE CONTROL
ELECTRICAL COMPONENTS

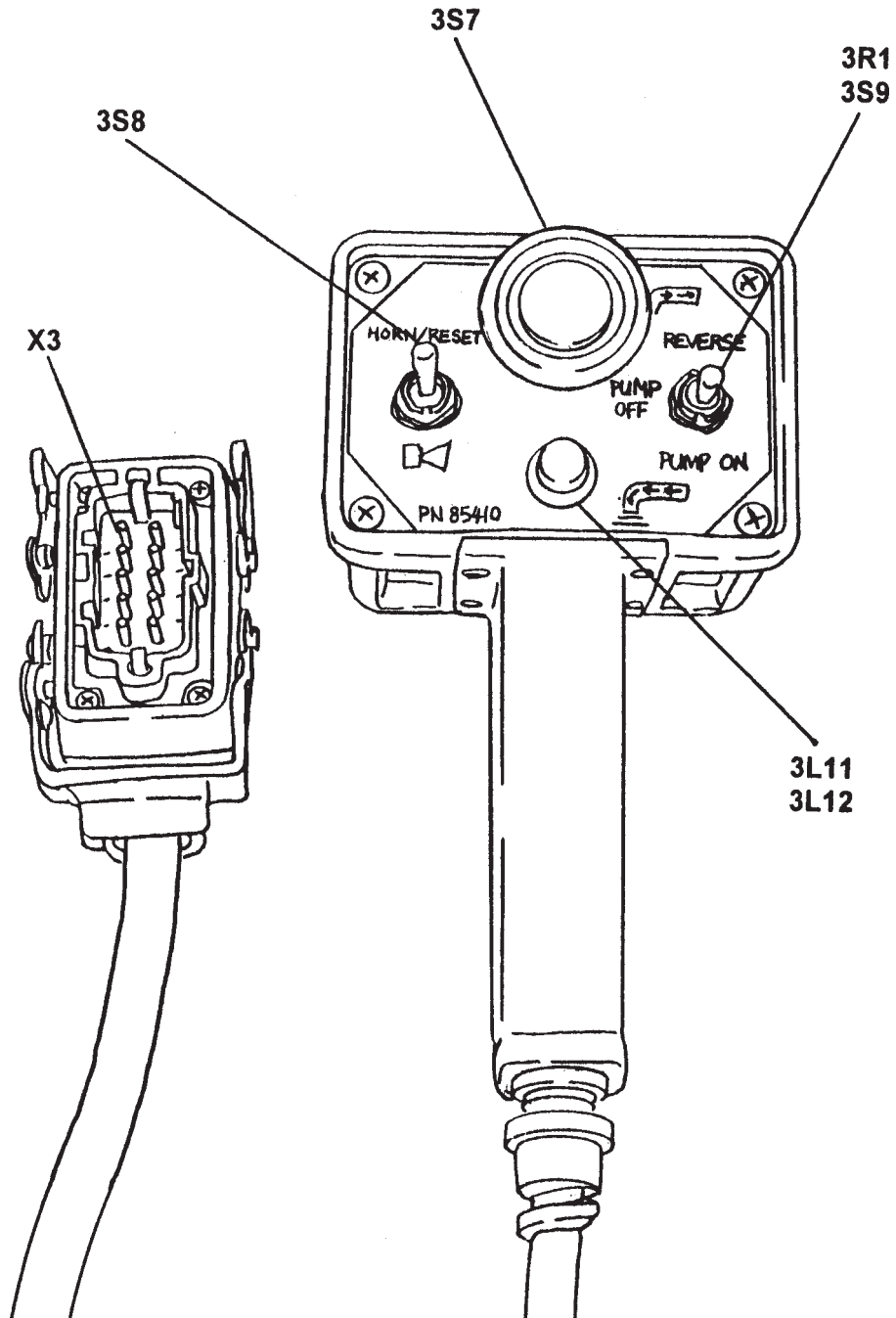

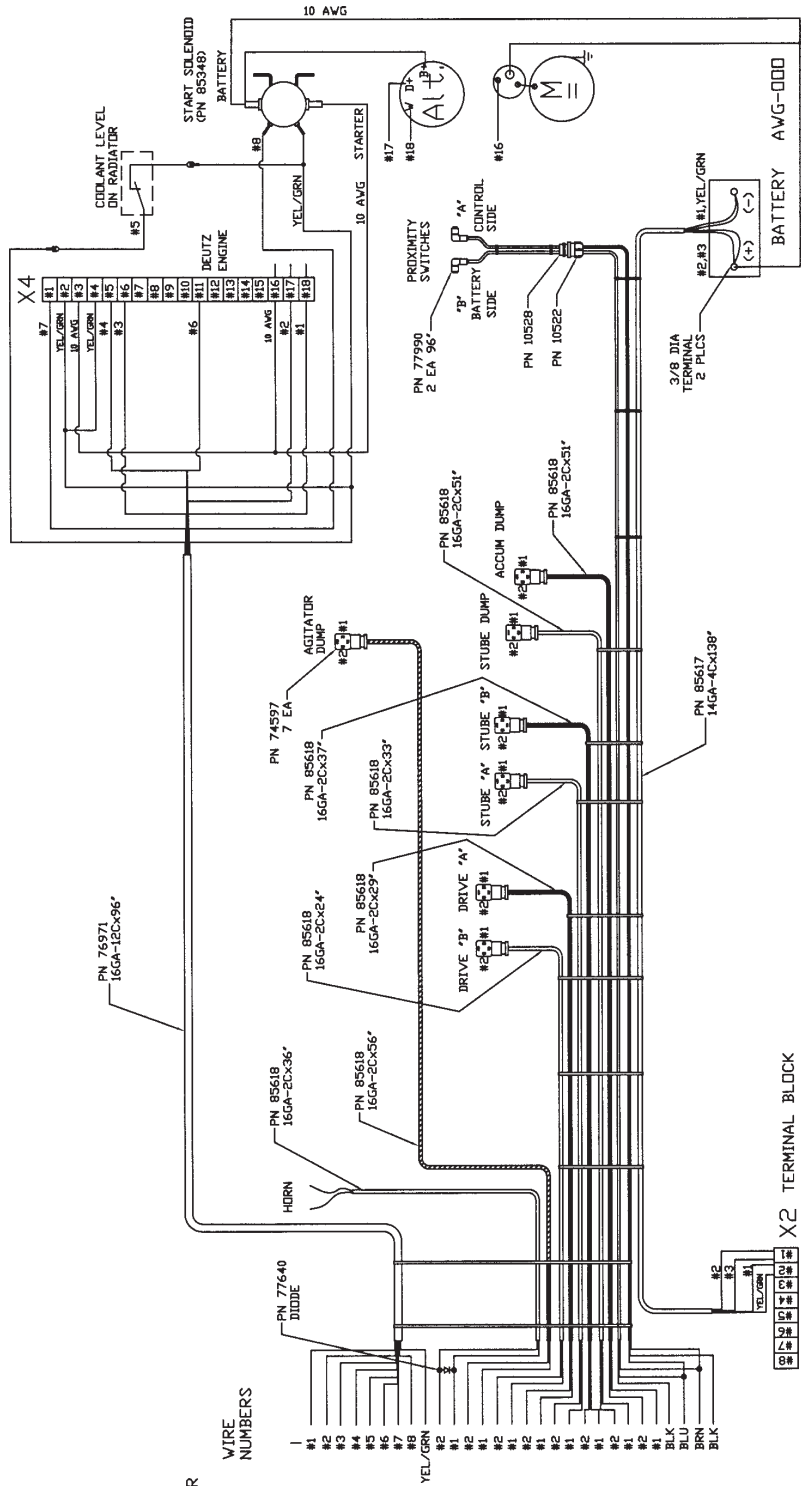

PN 800424 HOOD
PN 78695 INSERT
PN 801479 CONNECTOR

24 PIN PLUG X1

WIRE NUMBERS

- 1 TACHOMETER
- 2 ALTERNATOR
- 3 COOLANT TEMP
- 4 OIL TEMP
- 5 COOLANT LEVEL
- 6 OIL PRESSURE
- 7 FUEL SOLENOID
- 8 ENG. START
- 9 HORN
- 10 HORN +
- 11 AGITATOR DUMP -
- 12 AGITATOR DUMP +
- 13 DRIVE CYL 'B' -
- 14 DRIVE CYL 'B' +
- 15 DRIVE CYL 'A' -
- 16 DRIVE CYL 'A' +
- 17 STUBE 'A' -
- 18 STUBE 'A' +
- 19 STUBE 'B' -
- 20 STUBE 'B' +
- 21 STUBE DUMP -
- 22 STUBE DUMP +
- 23 ACCUM DUMP -
- 24 ACCUM DUMP +
- 25 PRDX SWITCH 'A'
- 26 GROUND
- 27 PRDX SWITCH 'B'
- 28 BRN
- 29 BLK
- 30 BLK

X2 TERMINAL BLOCK

REF-REED DRAWING No. 87194



TRAILER MOUNTED PUMP MODEL B50 TRAILER WIRING HARNESS

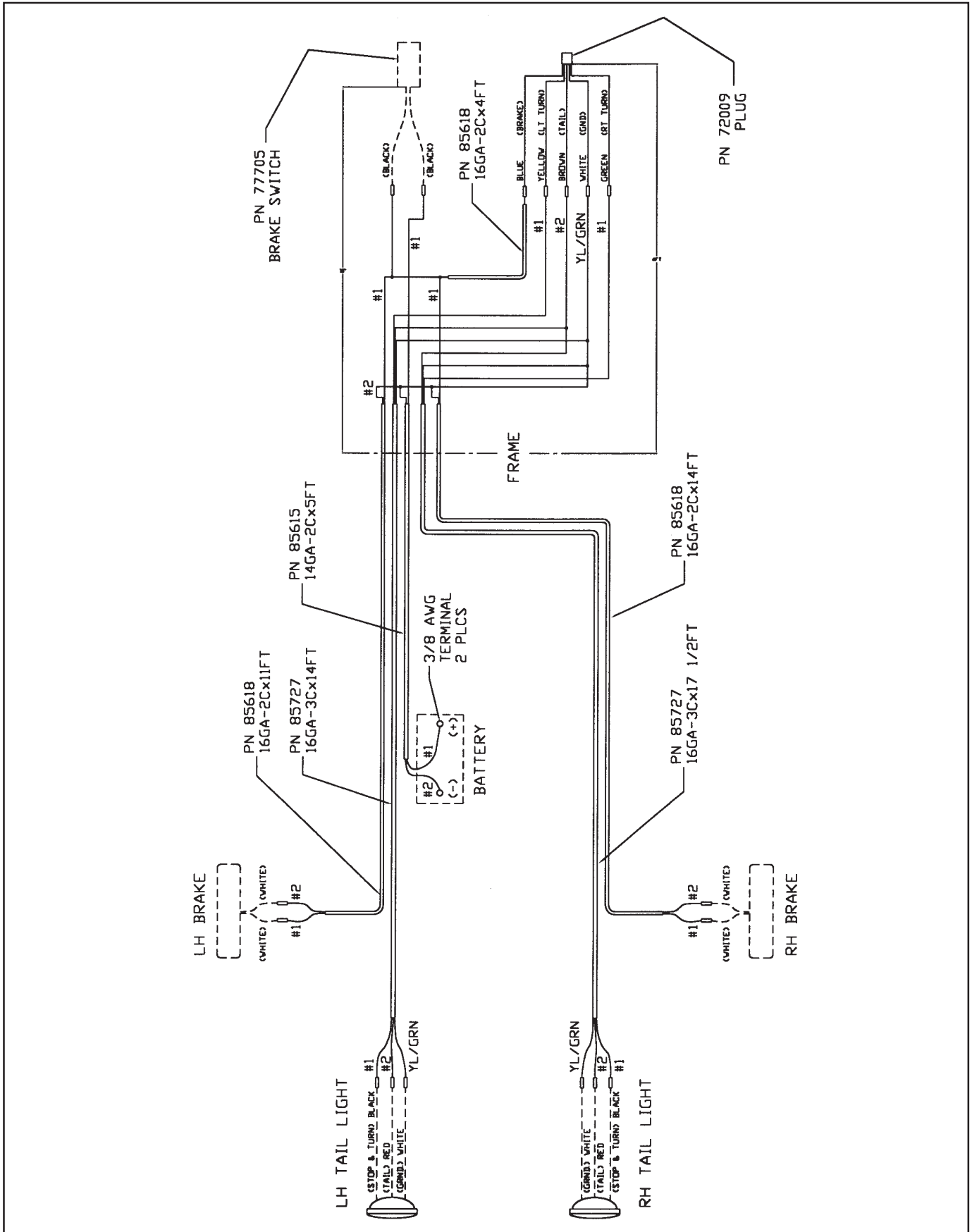

REVISION:

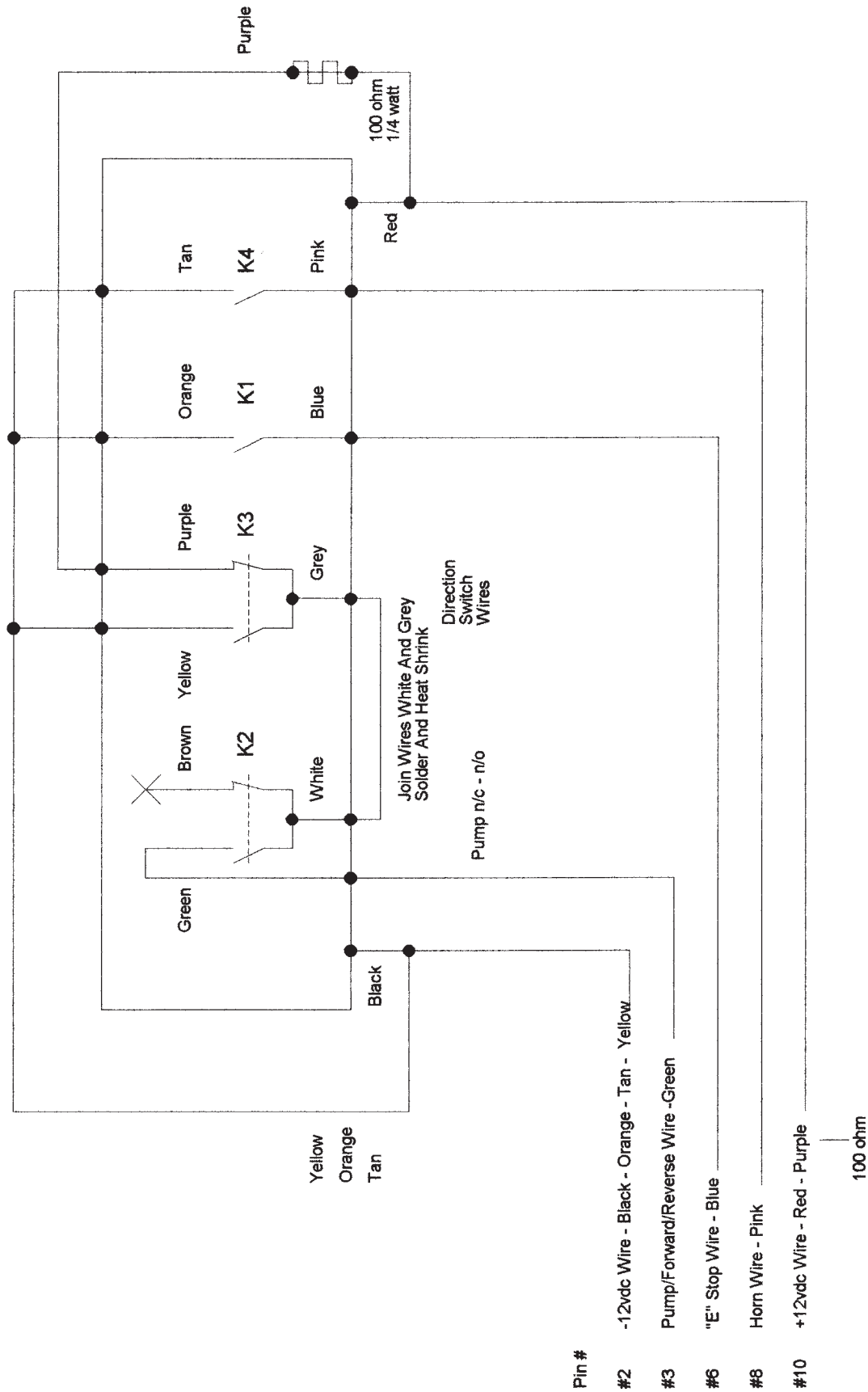



TRAILER MOUNTED PUMP MODEL B50 RADIO REMOTE CONTROL OPTION WIRING DIAGRAM

X3 PIN	FUNCTION
1	
2	GROUND
3	PUMP ON/REV.
4	
5	
6	'E' STOP
7	
8	HORN
9	
10	+12 vdc

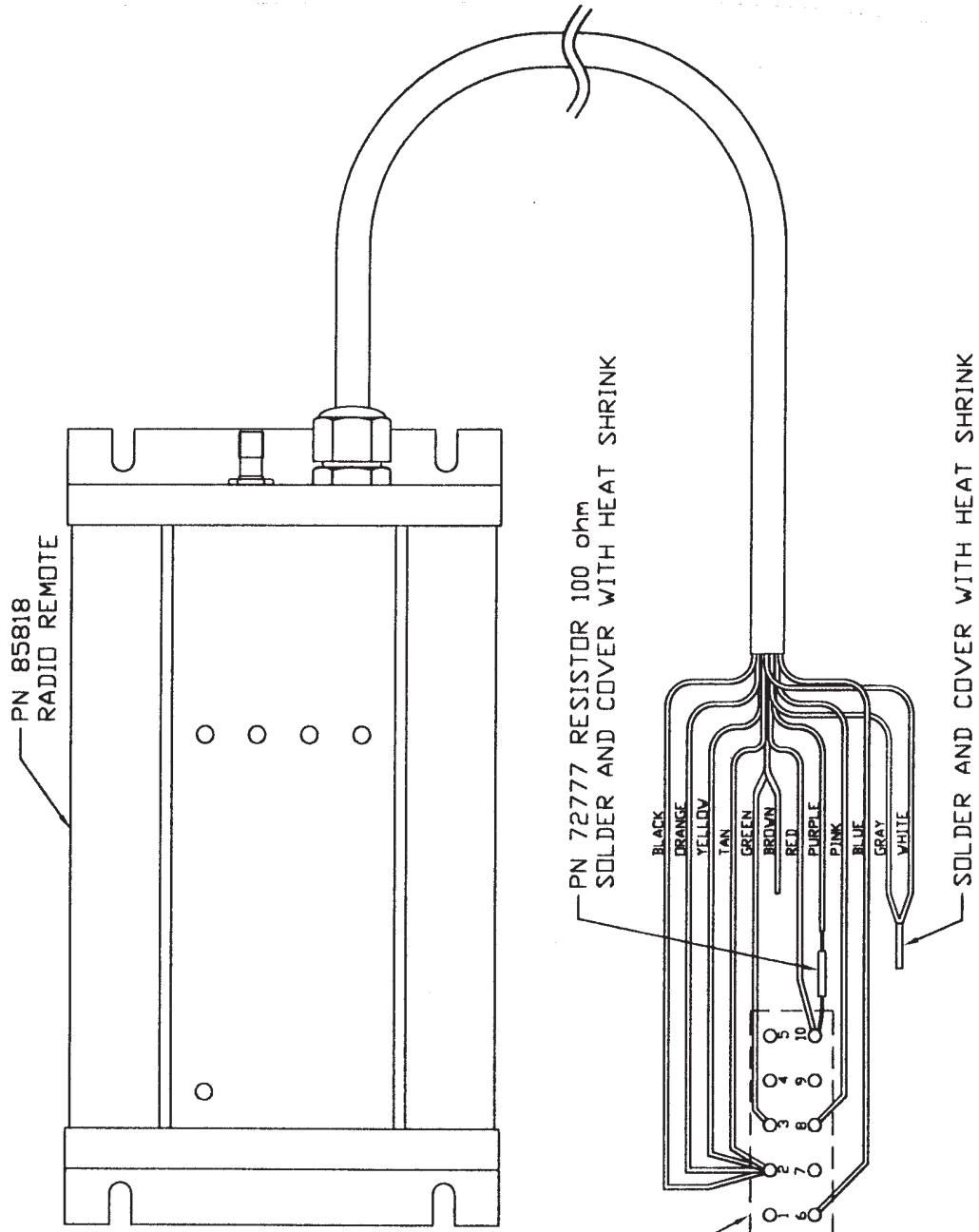

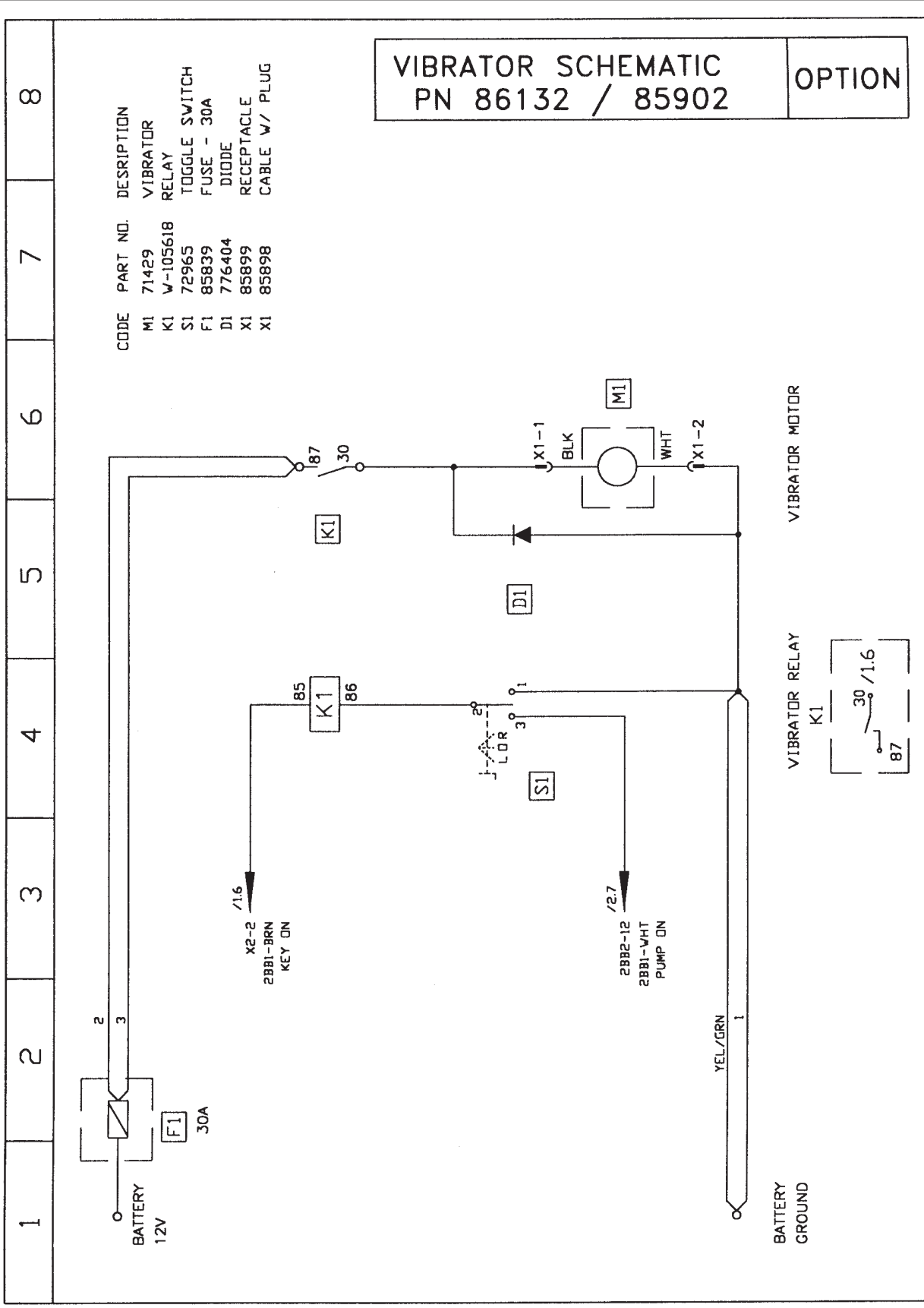



TRAILER MOUNTED PUMP MODEL B50 ENGINE THROTTLE OPTION ELECTRICAL SCHEMATIC

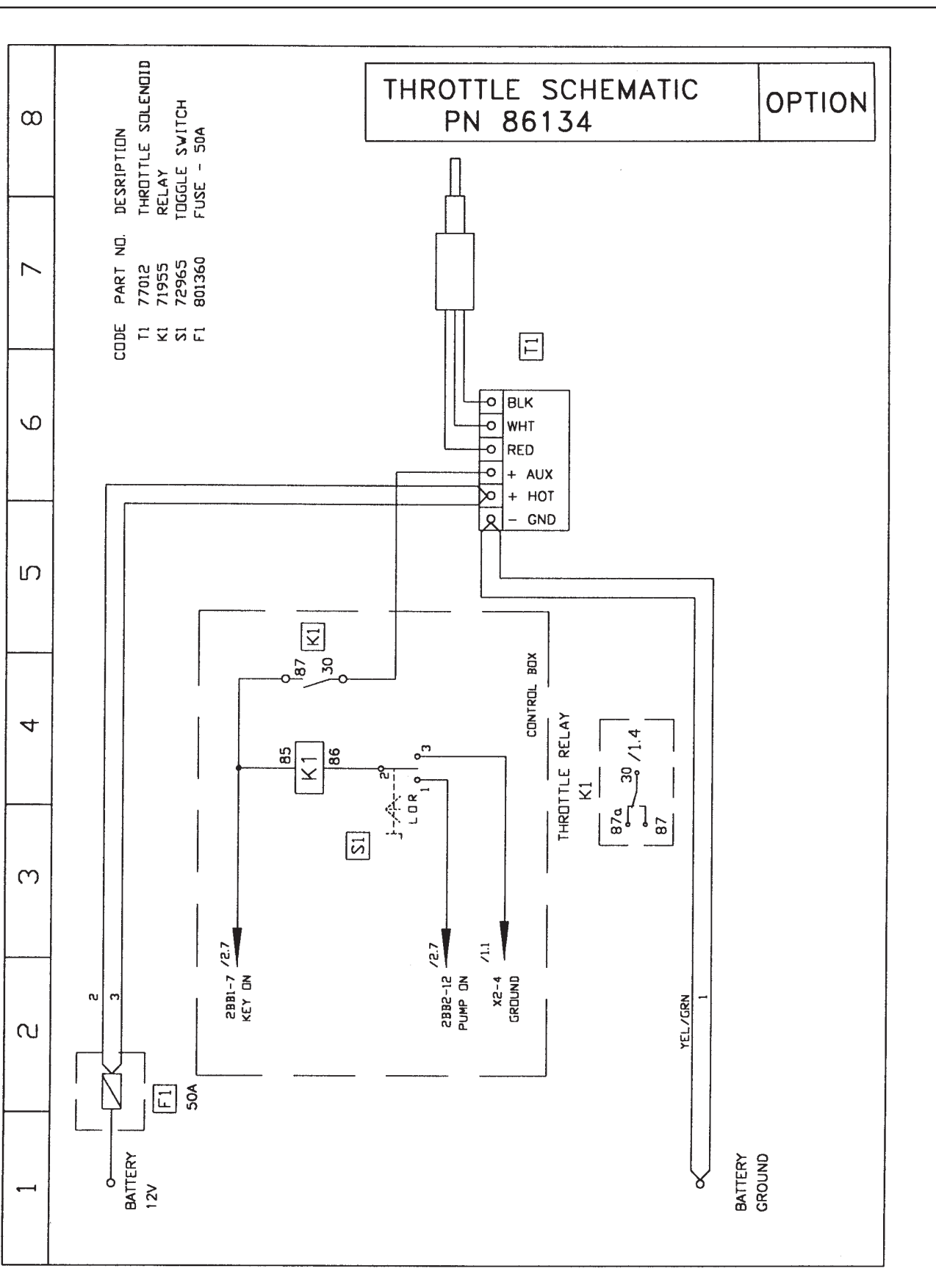

REVISION:



TRAILER MOUNTED PUMP MODEL B50 STROKE COUNTER OPTION ELECTRICAL SCHEMATIC

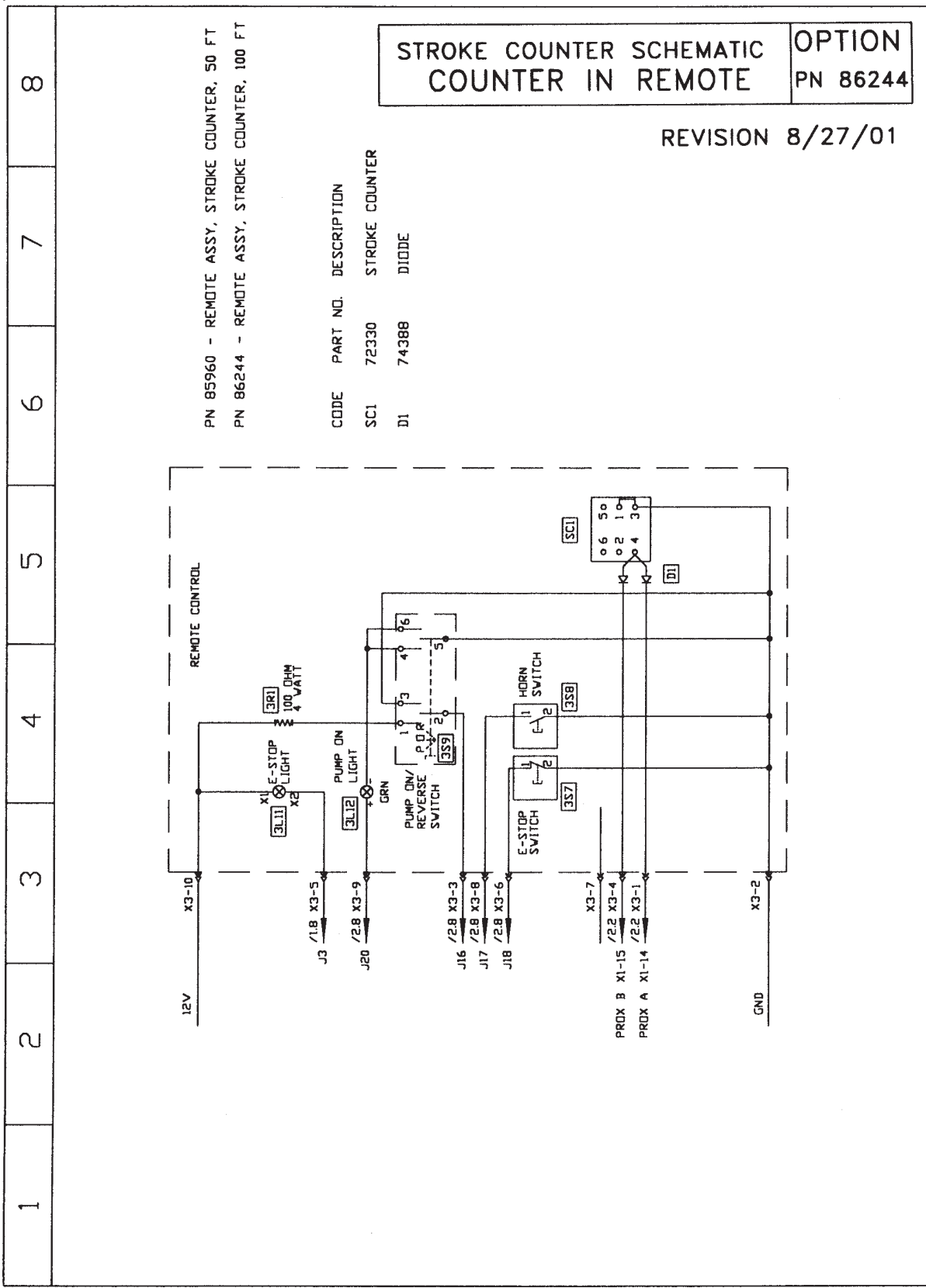

REVISION: