

REED B40 CONCRETE PUMP

SECTION 10:

PARTS INFORMATION, WARRANTY & SERVICE

PAGE

1	FRAME & AXLE ASSEMBLY
2	CONTROL PANEL
3	POWER TRAIN ASSEMBLY
4	HYDRAULIC PUMP AREA
5	HYDRAULIC VALVES
6	FLUSHBOX AREA
7	SWING RAM
8	CONCRETE & HYDRAULIC CYLINDERS
9	SWING TUBE ASSEMBLY OUTLET HOPPER
10	SWING TUBE ASSEMBLY OUTLET
11	AGITATOR ASSEMBLY

FRAME & AXLE ASSEMBLY

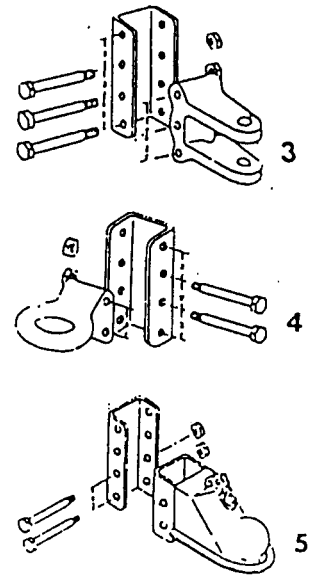
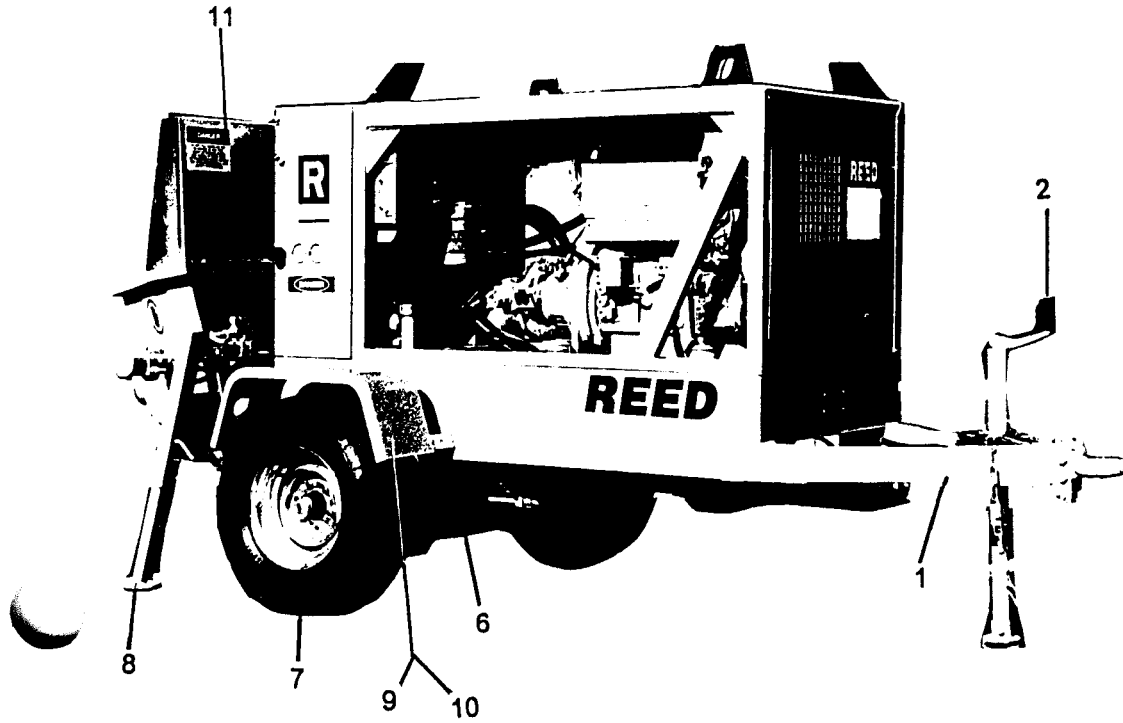

<u>ITEM</u>	<u>DESCRIPTION</u>	<u>PART#</u>	<u>QTY</u>
1	FRAME WELDMENT	79482	1
2	TOP WIND JACK	71060	1
3	CLEVIS	71050	1
4	LUNETTE EYE 3"	71051	1
5	COUPLER 2-5/16"	71099	1
6	AXLE	71005	1
7	WHEEL & TIRE	71066	2
8	OUTRIGGERS	76018	2
9	FENDER (LEFT)	71325	1
10	FENDER (RIGHT) NOT SHOWN	71437	1
11	SPLASH GUARD	72944	1

CONTROL PANEL

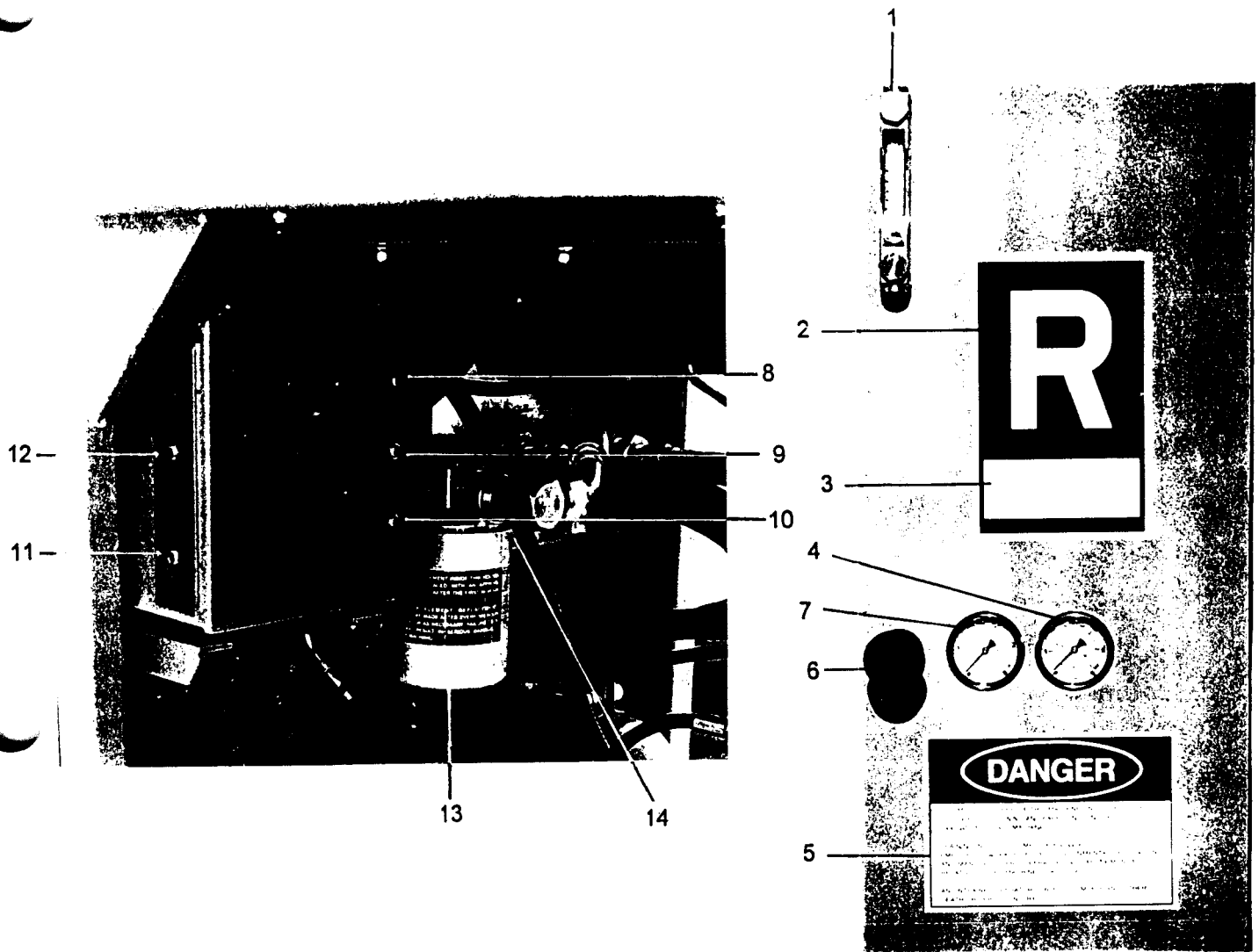

ITEM	DESCRIPTION	PART#	QTY
1	SIGHT GAUGE	74509	1
2	DECAL "R"	75026	1
3	DECAL "B30"	79454	1
4	GAUGE "3000 PSI"	70366	1
5	DECAL "DANGER"	75083	1
6	THROTTLE CABLE	79439	1
7	GAUGE "5000 PSI"	74562	1
8	SWITCH (MOM-OFF) TOGGLE	72826	1
9	SWITCH (MOM-OFF-MOM)	72964	1
10	SWITCH (ON-OFF)	72963	1
11	SWITCH (ON-OFF)	72963	1
12	SWITCH (ON-OFF-ON)	72965	1
13	HYDRAULIC OIL FILTER	79452	1
14	GAUGE (HYDRAULIC OIL FILTER)	79453	1

POWER TRAIN ASSEMBLY

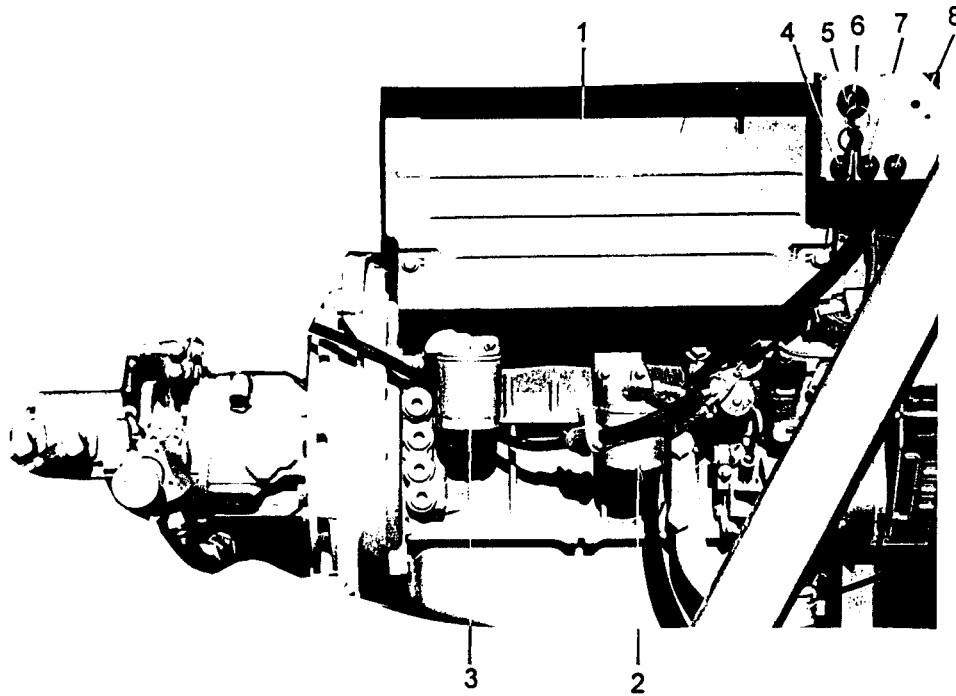

<u>ITEM</u>	<u>DESCRIPTION</u>	<u>PART#</u>	<u>QTY</u>
1	ENGINE TURBO	79440	1
2	FUEL FILTER	72960	1
3	OIL FILTER	72909	1
4	ALTERNATOR LIGHT	N/P/N	1
5	IGNITION SWITCH	72946	1
6	IGNITION KEY	71155	1
7	OIL TEMP LIGHT	N/P/N	1
8	OIL PRESSURE LIGHT	N/P/N	1

HYDRAULIC PUMP AREA

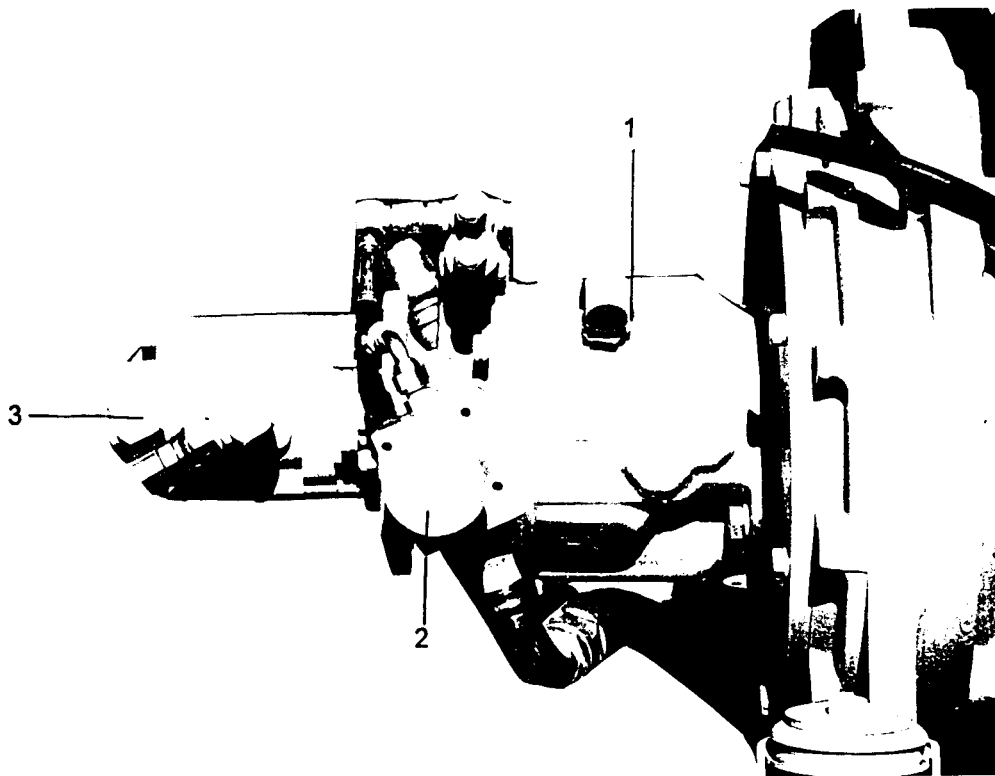

<u>ITEM</u>	<u>DESCRIPTION</u>	<u>PART#</u>	<u>QTY</u>
1	HYDRAULIC PUMP	79560	1
2	FLOW CONTROL ASSEMBLY	78189	1
3	AUXILIARY PUMP WITH REMIX	73156	1
4	AUXILIARY PUMP WITHOUT REMIX (NOT SHOWN)	72978	1

HYDRAULIC VALVES

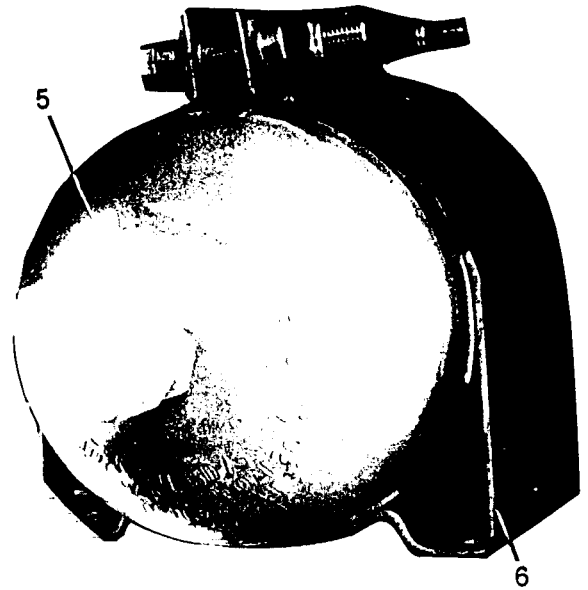
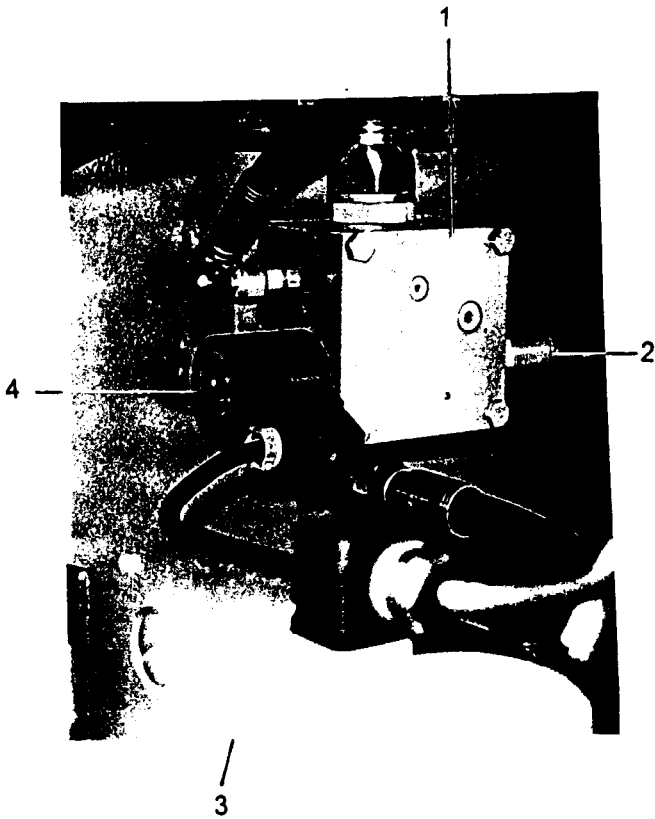

<u>ITEM</u>	<u>DESCRIPTION</u>	<u>PART#</u>	<u>QTY</u>
1	UNLOADER MANIFOLD	72803	1
2	UNLOADER CARTRIDGE	73155	1
3	DO5 VALVE	72984	1
4	COIL 12 VDC	73184	1
5	ACCUMULATOR	74515	1
6	ACCUMULATOR BRACKET	73171	2

FLUSHBOX AREA

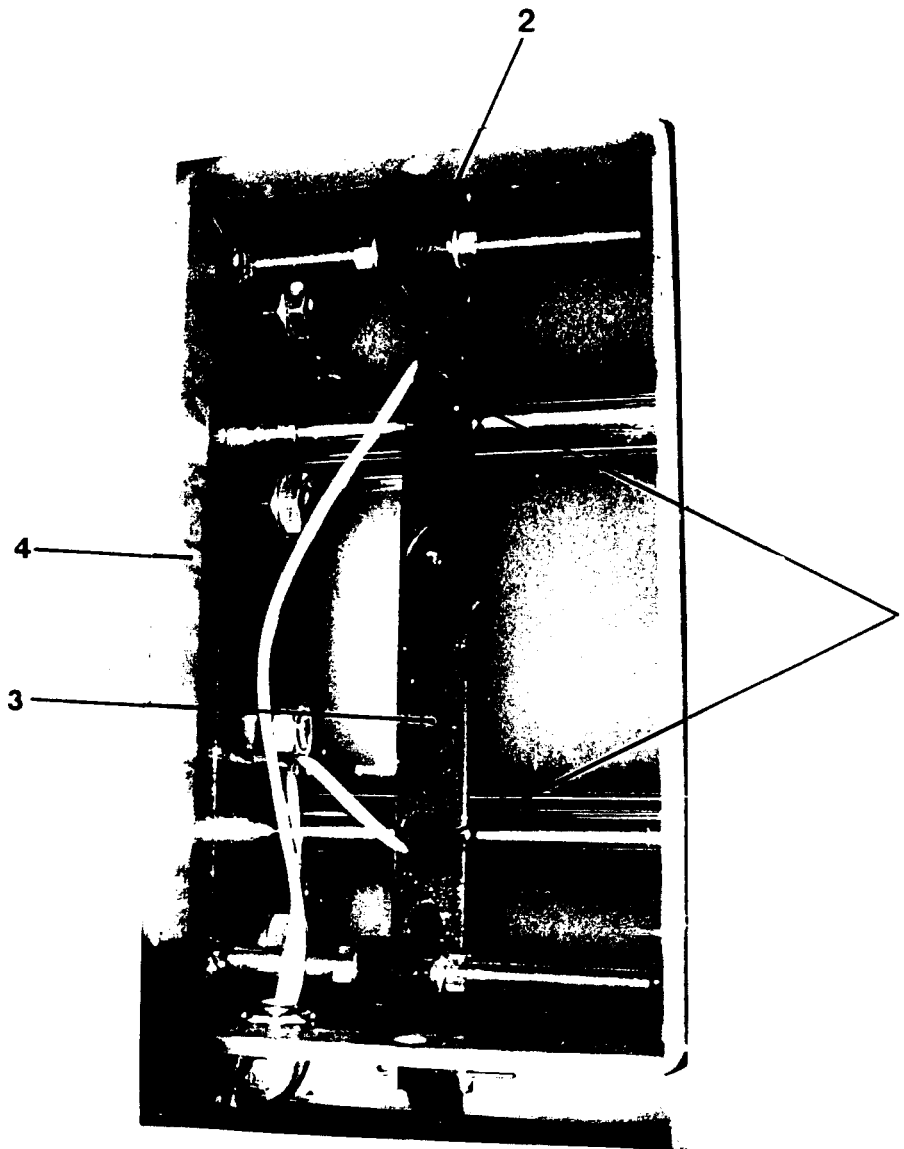

<u>ITEM</u>	<u>DESCRIPTION</u>	<u>PART#</u>	<u>QTY</u>
1	PROXIMITY SENSOR	72961	2
2	MOUNTING ANGLE	72940	2
3	MOUNTING BAR	72941	1
4	FLUSHBOX	73498	1

SWING RAM

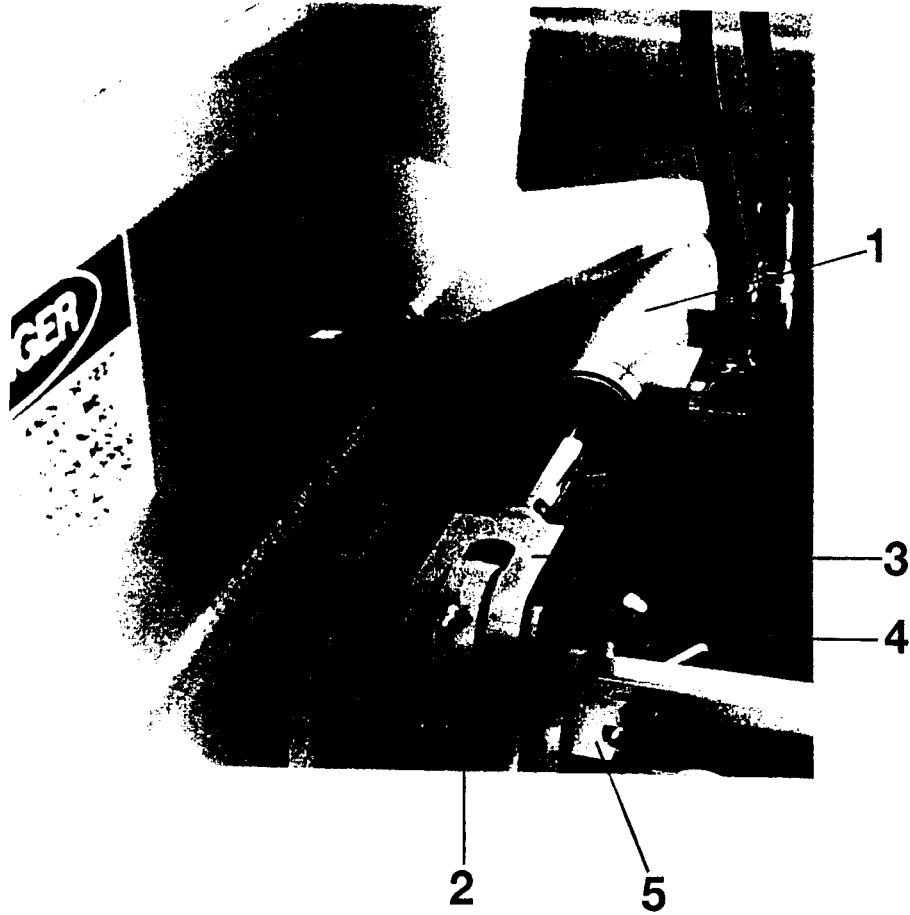

<u>ITEM</u>	<u>DESCRIPTION</u>	<u>PART#</u>	<u>QTY</u>
1	SWING TUBE HYDRAULIC CYLINDER	75087	1
2	BELL CRANK	70127	1
3	CLEVIS	70142	1
4	CLEVIS PIN	70143	1
5	CASTLE NUT	70825	1
6	NUT SPACER	70125	1

CONCRETE & HYDRAULIC CYLINDERS

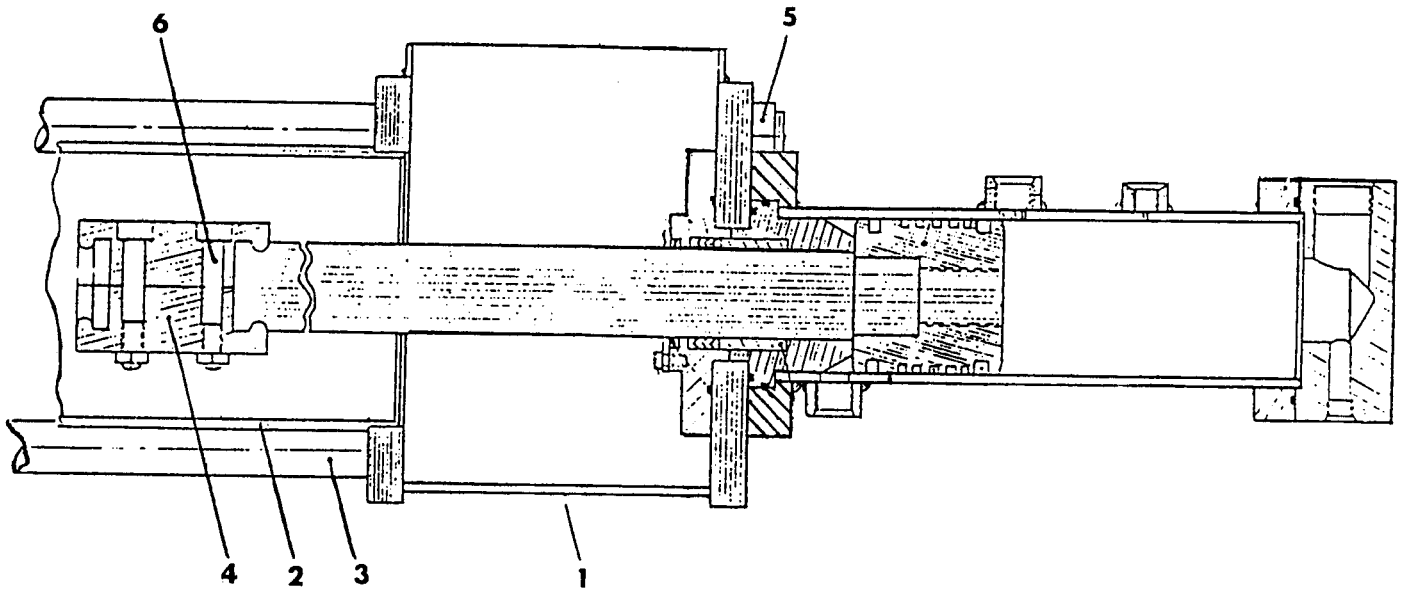

<u>ITEM</u>	<u>DESCRIPTION</u>	<u>PART#</u>	<u>QTY</u>
1	FLUSHBOX	73498	1
2	CONCRETE CYLINDERS	73497	2
3	TIE ROD CONCRETE CYLINDER	75882	4
4	COUPLING ASSEMBLY MATCHED PAIR	73425	2
5	NUT 1 1/4" - 12 (CONCRETE TIE ROD)		4
6	SOCKET HEAD CAP SCREW (1 1/2" - 20 X 3")		
7	HYDRAULIC CYLINDER ASSEMBLY - COMPLETE	70986	2

SWING TUBE ASSEMBLY OUTLET HOPPER

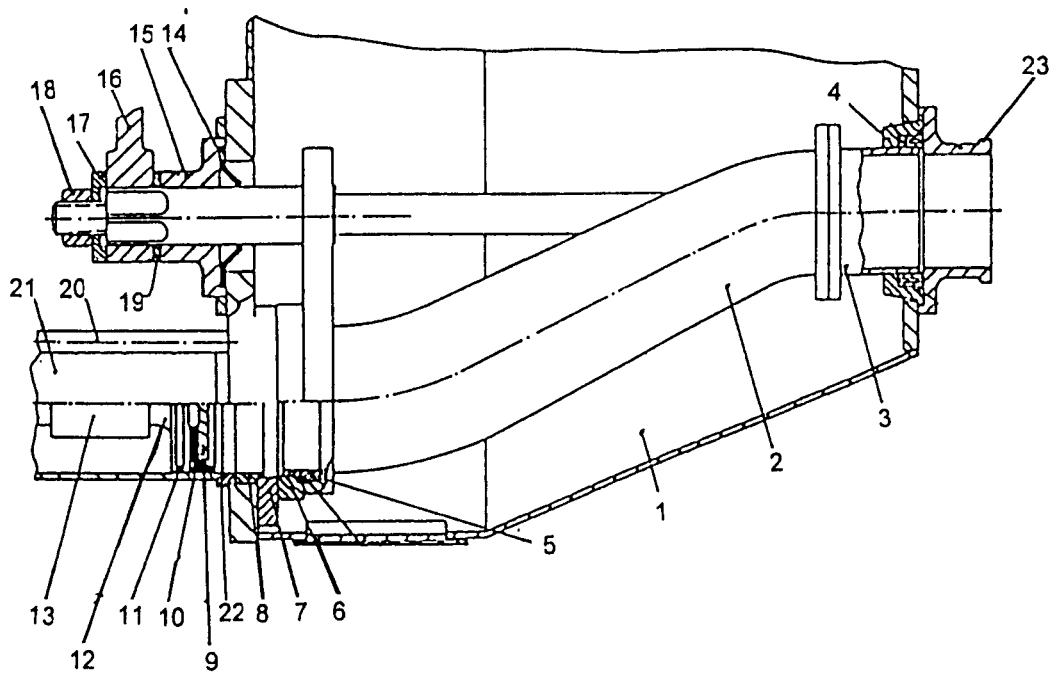

<u>ITEM</u>	<u>DESCRIPTION</u>	<u>PART#</u>	<u>QTY</u>
1	HOPPER	73055	1
2	SWING TUBE ASSEMBLY (SQUARE SHAFT)	73190	1
3	OUTLET CHROMED	70042	1
4	OUTLET SEAL HOUSING	77760	1
5	THRUST RING	73406	1
6	WEAR RING	73407	1
7	WEAR PLATE (REVERSIBLE)	77852	1
8	ANTI-CHIP RING	70047	2
9	PISTON PLATE	70057	2
10	PISTON CUP 6"	70048	2
11	O-RING 433	74001	2
12	CONCRETE PISTON ADAPTOR	70076	2
13	PISTON COUPLING	77896	2
14	SEAL (FLANGE BEARING)	73564	1
15	FLANGED BEARING	70124	1
16	BELL CRANK	70127	1
17	NUT SPACER	70125	1
18	CASTLE NUT	70825	1
19	THRUST WASHER	70141	1
20	TIE ROD CONCRETE CYLINDER	75882	4
21	CONCRETE CYLINDER	73497	2
22	ADAPTOR RING 7" TO 6"	70318	2
23	OUTLET 5"	73247	1

SWING TUBE ASSEMBLY OUTLET

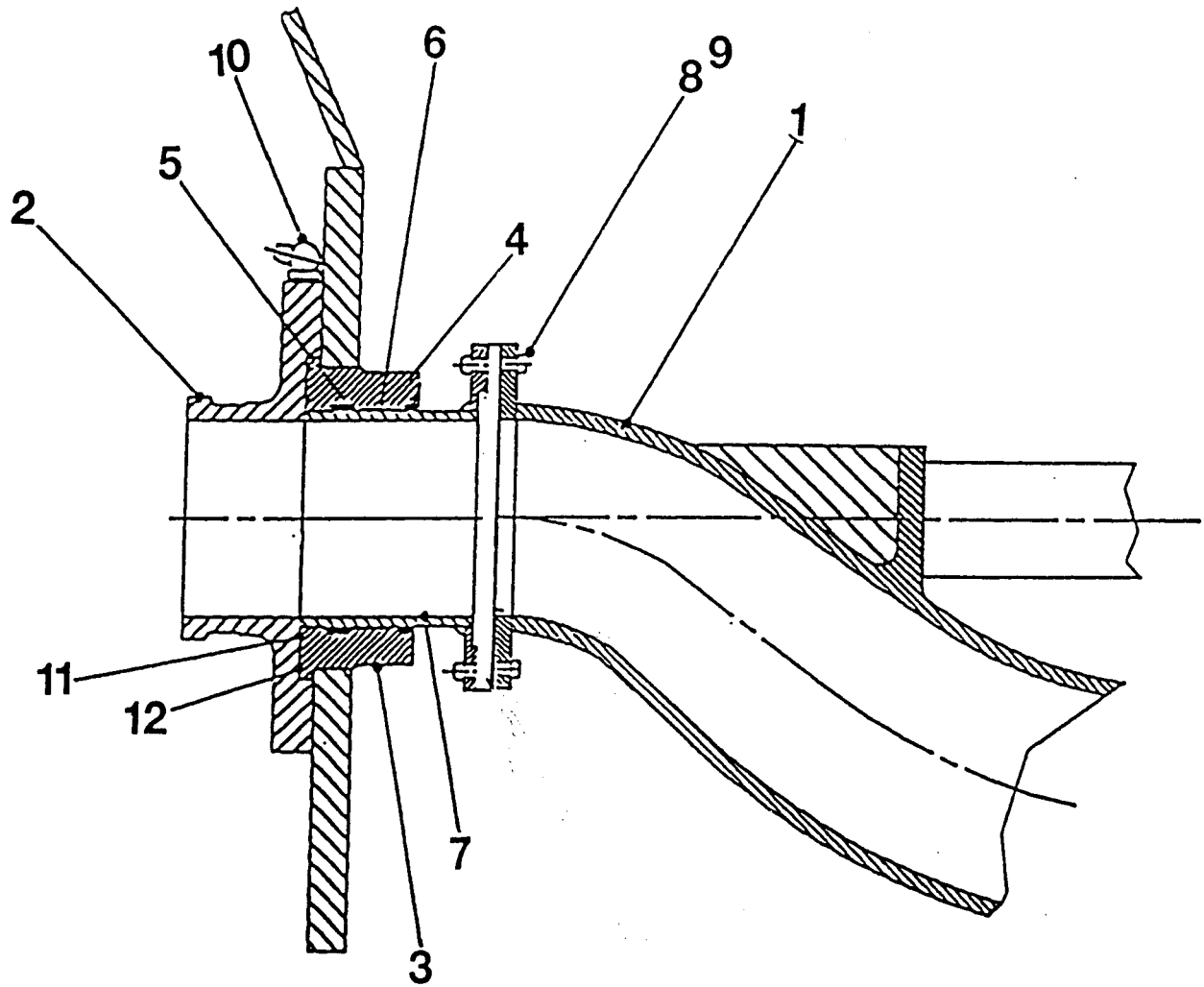

<u>ITEM</u>	<u>DESCRIPTION</u>	<u>PART#</u>	<u>QTY</u>
1	SWING TUBE ASSEMBLY	73190	1
2	OUTLET CASTING 5"	73247	1
3	OUTLET SEAL HOUSING	77760	1
4	OUTLET SEAL	77764	1
5	OUTLET SEAL	77765	1
6	GUIDE BAND	77763	1
7	CHROMED OUTLET	70042	1
8	BOLT	N/P/N	6
9	NUT	N/P/N	6
10	1/4-28 GREASE FITTING	N/P/N	1
11	O-RING	77762	1
12	O-RING	77761	1

AGITATOR ASSEMBLY

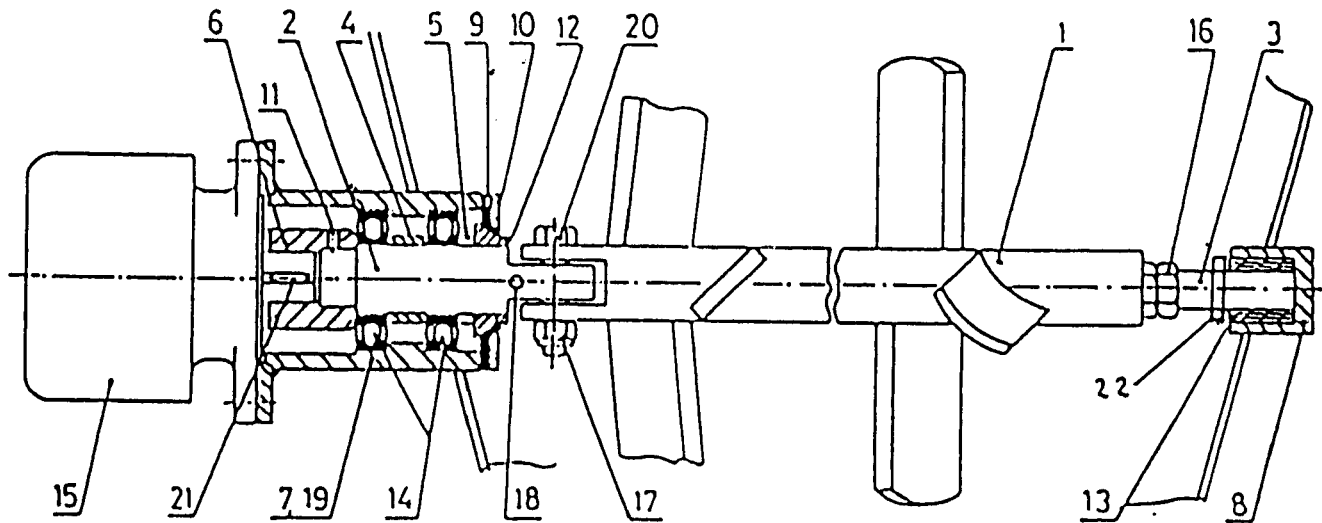

ITEM	DESCRIPTION	PART#
1	AGITATOR SHAFT WITH PADDLES	72851
2	SHAFT	70224
3	IDLER SHAFT	70214
4	SPACER LONG	70215
5	SPACER SHORT	70216
6	MOTOR COUPLING	70225
7	BEARING HOUSING	70223
8	IDLER BEARING HOUSING	70210
9	SEAL	70212
10	SEAL FLANGE	70211
11	SET SCREW	80374
12	WEAR RING	71018
13	IDLER BEARING <i>Bushing</i>	70219*
14	BEARING SINGLE ROW BALL	71019
15	HYDRAULIC MOTOR	74529
16	HEX NUT M 20	80030
17	HEX NUT SELF-LOCKING 1/2-13	80019
18	SPRING PIN 3/16 X 1 3/4	80298
19	GREASE FITTING	80516
20	HEX HEAD CAP SCREW 1/2-13 X 2 1/2	80156
21	KEY	30216
22	SPACER	77877
23	AGITATOR ASSEMBLY (COMPLETE)	72850



PN 77011 - REMOTE CONTROL ASSEMBLY WITH STROKE COUNTER

MLO

ITEM NO.	REED'S PART NO.	DESCRIPTION	QTY
1		Remote Control (w/Stroke Counter)	1
2		Stroke Counter	1
3		Stroke Counter Housing	1
4		Stroke Counter Knob	1
5		Stroke Counter Switch	1
6		Stroke Counter Bracket	1
7		Cable	1
8		Stroke Counter Housing Cap	1
9		Stroke Counter Housing Cap Gasket	1
10		Stroke Counter Housing Screw	1
11		Stroke Counter Housing Gasket	1
12		Stroke Counter Housing Spring	1

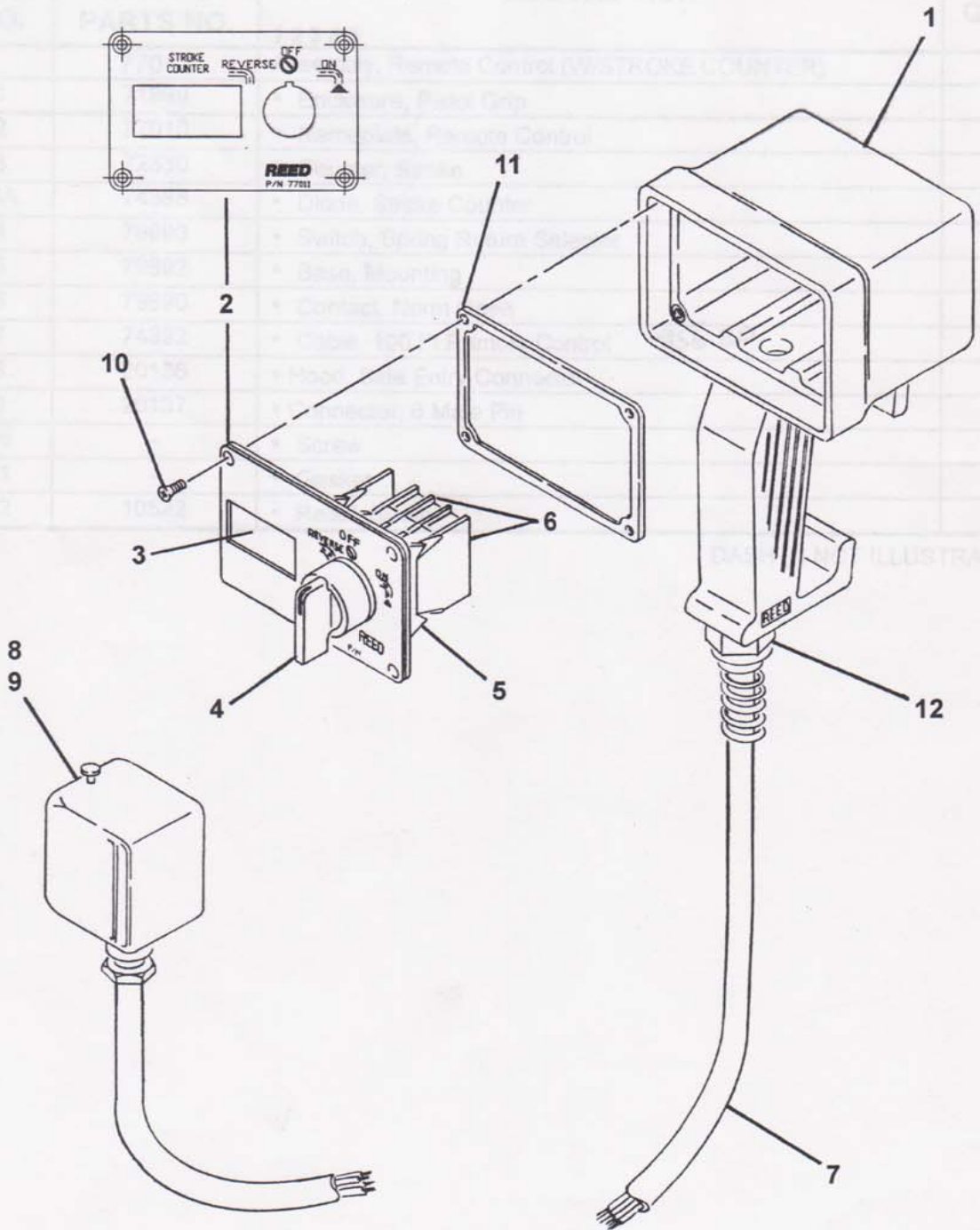

PN 77011 - REMOTE CONTROL ASSEMBLY WITH STROKE COUNTER

PN 77011 - REMOTE CONTROL ASSEMBLY
WITH STROKE COUNTER

ITEM NO.	REED'S PARTS NO.	DESCRIPTION	QTY
		1 2 3 4 5	
	77011	Assembly, Remote Control (W/STROKE COUNTER)	1
1	71999	• Enclosure, Pistol Grip	1
2	77010	• Nameplate, Remote Control	1
3	72330	• Counter, Stroke	1
-3A	74388	• Diode, Stroke Counter	1
4	79893	• Switch, Spring Return Selector	1
5	79892	• Base, Mounting	1
6	79890	• Contact, Norm Open	3
7	74392	• Cable, 100 Ft Remote Control <i>856 20</i>	1
8	20136	• Hood, Side Entry Connector	1
9	20137	• Connector, 6 Male Pin	1
10	-	• Screw	4
11	-	• Gasket	1
12	10522	• Relief, Strain	1

DASH (-) NOT ILLUSTRATED

