



TRAILER MOUNTED PUMP MODEL *B20* SCHEMATICS SECTION

SCMTC

FIGURE 00
PAGE 00

REED TRAILER MOUNTED CONCRETE PUMP MODEL *B20* ILLUSTRATED PARTS
MANUAL: SCHEMATICS SECTION CONTAINS THE FOLLOWING FIGURES:

FIGURE	00	TABLE OF CONTENTS
FIGURE	01	DRIVE CYLINDER CIRCUIT
FIGURE	02	SINGLE SHIFT SWING TUBE CIRCUIT
FIGURE	03	DUAL SHIFT SWING TUBE CIRCUIT
FIGURE	04	AGITATOR/OUTRIGGERS OPTIONS CIRCUIT
FIGURE	05	HYDRAULIC HOSE KIT
FIGURE	06	ELECTRICAL COMPONENTS-CONTROL PANEL
FIGURE	07	ELECTRICAL COMPONENTS-CABLE REMOTE CONTROL
FIGURE	08	ENGINE WIRING HARNESS
FIGURE	09	TRAILER WIRING HARNESS
FIGURE	10	PN 87346-2 MAIN CONTROL BOX DATA
FIGURE	11	PN 87425-2 MAIN CONTROL BOX SCHEMATIC
FIGURE	12	PN 87347-1 PENDANT CONTROL BOX DATA & SCHEMATIC
FIGURE	13	CONTROL PANEL MOD. FOR STROKE COUNTER-OPTION
FIGURE	14	DOCUMENT-TRANSMITTER RF I.D. TEACH PROCEDURE
FIGURE	15	WIRING SYSTEM - REWORK
FIGURE	16	HYDRAULIC DIAGRAM - MIXER



REVISION:



TRAILER MOUNTED PUMP MODEL B20 DRIVE CYLINDER CIRCUIT HYDRAULIC COMPONENTS & SCHEMATIC

SCMTC

FIGURE 01
PAGE 01

B SERIES DRIVE CYLINDER CIRCUIT
HYDRAULIC SCHEMATIC

DATE
12/3/01

REV.

PART NO.
86708

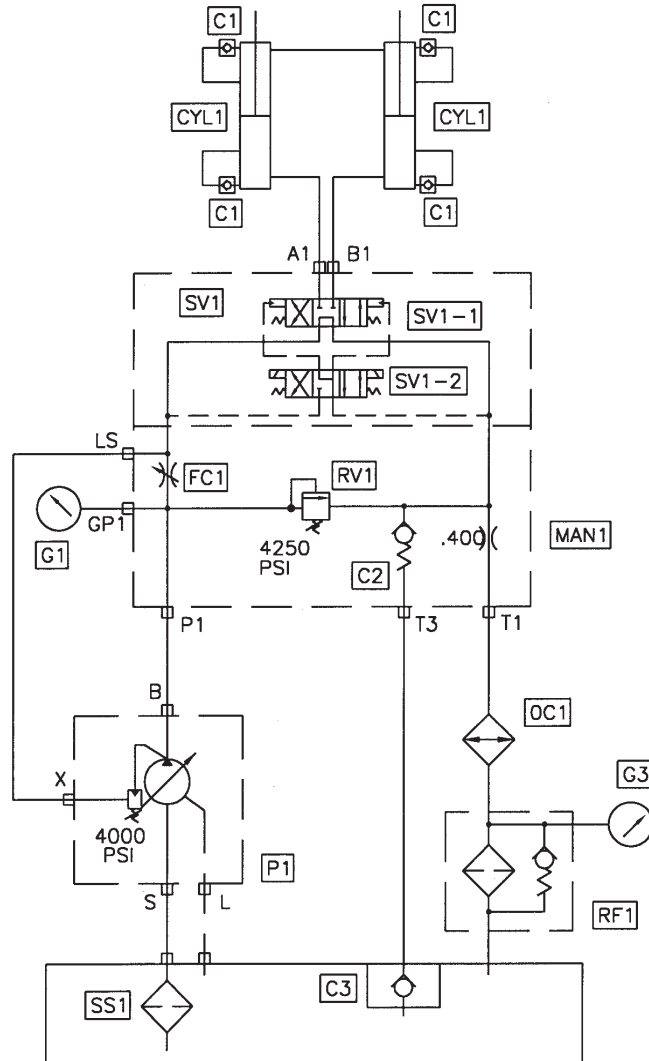

CODE	DESCRIPTION	PART NO.	QTY.
P1	Main Pump, Parts, Group 40		
CYL1	Hydraulic Drive Cylinder, Parts Group 60		
MAN1	Manifold Drive Cylinder Circuit	85248	1
SV1	Solenoid Valve, Drive Cylinder Circuit	85689	1
SV1-1	Solenoid Valve Main	85690	1
SV2-2	Solenoid Valve Pilot	85691	1
	Coil For SV2-2	85692	2
RV1	Relief Valve Cartridge	85696	1
FC1	Flow Control Valve Cartridge	85697	1
C1	Check Valve	78961	4
C2	Check Valve Cartridge	85698	1
C3	Check Valve	85574	1
G1	Pressure Gauge 6000 psi	74562	1
G3	Pressure Gauge Return	85575	1
OC1	Oil Cooler	85713	1
RF1	Return Filter	85282	1
	Return Filter Element	85283	1
SS1	Magnetic Suction Strainer 2"	801024	1

REVISION:



TRAILER MOUNTED PUMP MODEL B20 SINGLE SHIFT SWING TUBE CIRCUIT HYDRAULIC COMPONENTS & SCHEMATIC

SCMTC

FIGURE 02
PAGE 02

B & C SERIES SWING TUBE HYDRAULIC SCHEMATIC, SINGLE SHIFT CYLINDER

DATE
11/7/01

REV.

PART NO.
86705

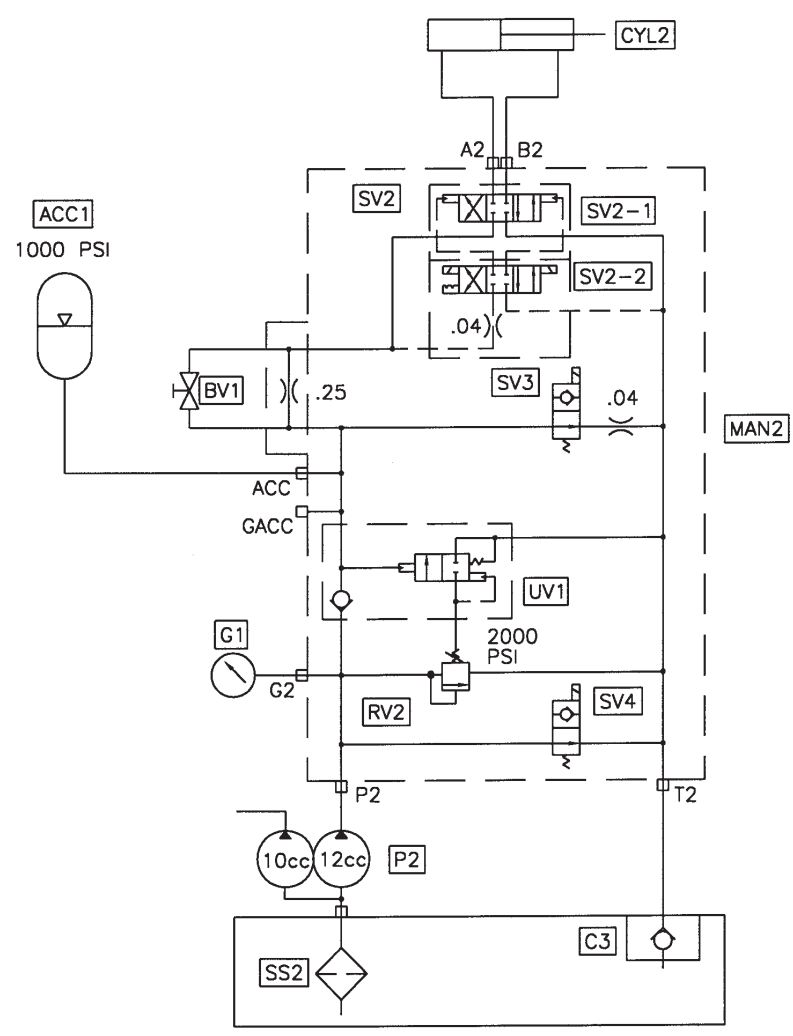

CODE	DESCRIPTION	PART NO.	QTY.
P2	Gear Pump, Parts, Group 40	73156	1
CYL2	S Tube Single Shift Cylinder	86221	1
MAN2	Manifold S Tube Circuit	85249	1
SV2	Solenoid Valve S Tube Circuit	85693	1
SV2-1	Solenoid Valve Main	85694	1
SV2-2	Solenoid Valve Pilot	85695	1
	Coil For SV2-2	85692	2
SV3	Solenoid Valve Cartridge	85699	1
	Coil For SV3	85700	1
SV4	Solenoid Valve Cartridge	85701	1
	Coil For SV4	85702	1
RV2	Relife Valve Cartridge	85703	1
UN1	Unlodng Valve Cartridge	85704	1
BV1	Ball Valve	85705	1
ACC1	Accumulator	74515	1
	Accumulator, Bladder	74516	1
G2	Pressure Gauge 3000 PSI	70366	1
SS2	Magnetic Suction Strainer 1 1/4"	79247	1
C3	Check Valve	85574	1

REVISION:



TRAILER MOUNTED PUMP MODEL B20 DUAL SHIFT SWING TUBE CIRCUIT HYDRAULIC COMPONENTS & SCHEMATIC

SCMTC

FIGURE 03
PAGE 03

B & C SERIES SWING TUBE HYDRAULIC SCHEMATIC, DUAL SHIFT CYLINDER

DATE
11/7/01

REV.
PART NO.
86706

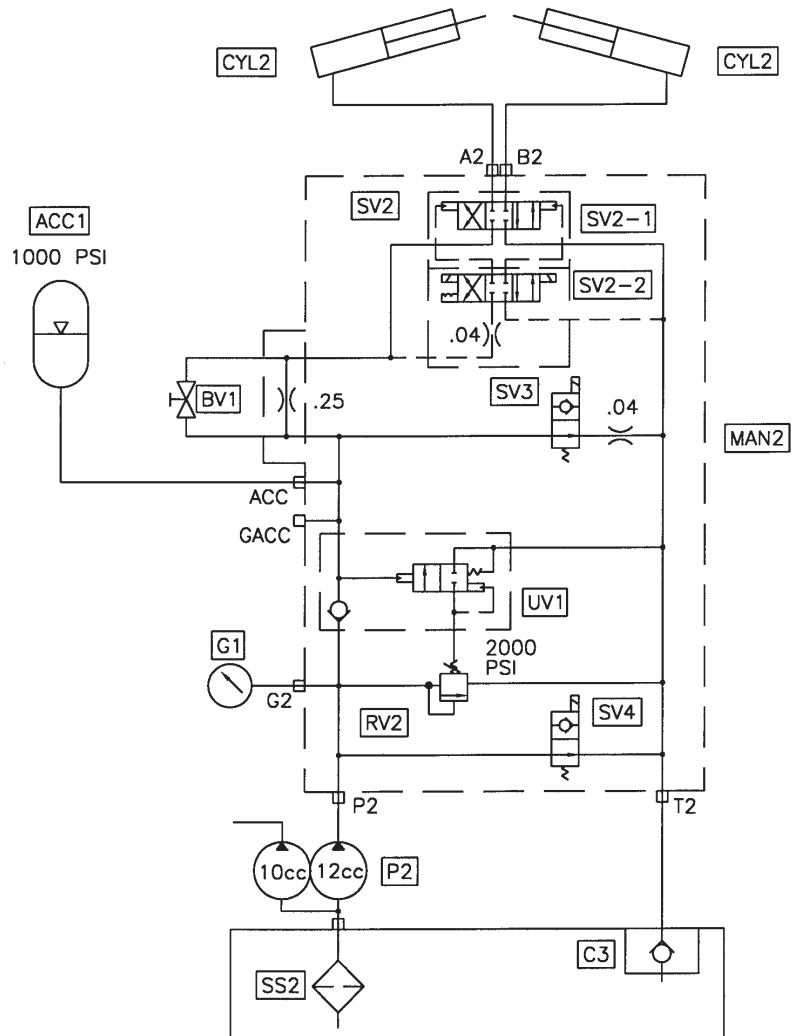

CODE	DESCRIPTION	PART NO.	QTY.
P2	Gear Pump, Parts, Group 40		
CYL2	S Tube Single Shift Cylinder	86220	2
MAN2	Manifold S Tube Circuit	85249	1
SV2	Solenoid Valve S Tube Circuit	85693	1
SV2-1	Solenoid Valve Main	85694	1
SV2-2	Solenoid Valve Pilot	85695	1
	Coil For SV2-2	85692	2
SV3	Solenoid Valve Cartridge	85699	1
	Coil For SV3	85700	1
SV4	Solenoid Valve Cartridge	85701	1
	Coil For SV4	85702	1
RV2	Relife Valve Cartridge	85703	1
UN1	Unloading Valve Cartridge	85704	1
BV1	Ball Valve	85705	1
AAC1	Accumulator	74515	1
	Accumulator, Bladder	74516	1
G2	Pressure Gauge 3000 PSI	70366	1
SS2	Magnetic Suction Strainer 1 1/4"	79247	1
C3	Check Valve	85574	1

REVISION:



**TRAILER MOUNTED PUMP MODEL B20
AGITATOR / OUTRIGGER OPTION CIRCUIT
HYDRAULIC COMPONENTS & SCHEMATIC**

B & C SERIES AGITATOR/OUTRIGGER OPTION SCHEMATIC

DATE
11/7/01

REV.
A

PART NO.
86707

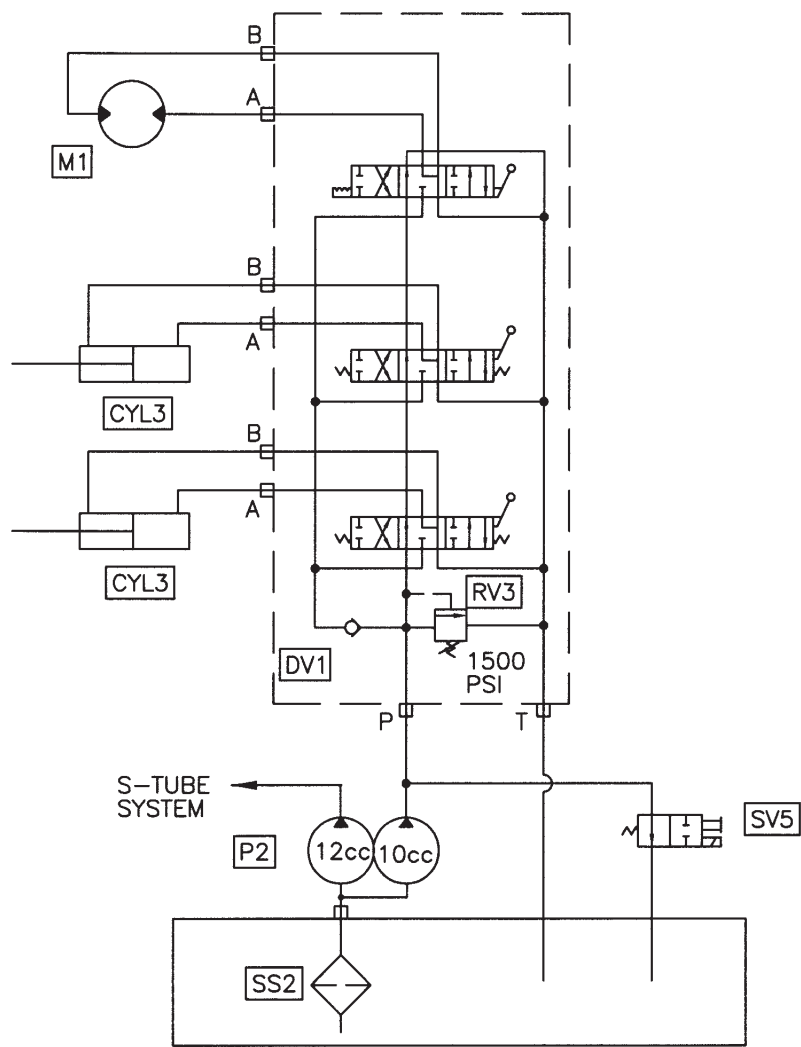

CODE	DESCRIPTION	PART NO.	QTY.
P2	Gear Pump, Parts, Group 40	73156	1
CYL3	Hydraulic Outrigger Cylinder	86220	2
DV1	Directional Valve Agitator/Outrigger	74471	1
RV3	Relife Valve Cartrige	85706	1
M1	Agitator Motor, Parts, Group 20		
SV5	Solenoid Valve	87154	1
	Coil For SV5	87155	1
SS2	Magnetic Suction Strainer 1 1/4"	79247	1

REV A-10/04/2004

REVISION:



**TRAILER MOUNTED PUMP MODEL B20
HYDRAULIC HOSE KIT**

SCMTC

FIGURE 05
PAGE 05

HOSE KIT 87797	
Part No.	End #1
85666-001	
85666-006	
85666-013	
85667-001	
85654-016	
85657-002	
85657-002	
85657-002	
85657-033	
85657-004	
85654-021	
85657-016	
85664-011	
85657-001	
85660-004	
85659-001	
85657-030	
85659-002	
85659-002	
85659-002	
85659-002	

SUCTION HOSES - POWER TRAIN

Part No.	End #1
	Tank Suction
	Tank Suction
	Tank Suction

FUEL HOSES - 85363 FUEL TANK ASSY

Part No.	End #1
	Fuel Tank Suction
	Fuel Filter "OUT"
74716	Engine

CONTROL VALVE GROUP - 86329

Part No.	End #1
85657-016	Bulkhead "P"
85658-011	Agitator Valve "A"
85658-010	Agitator Valve "B"

HYD OUTRIGGER GROUP - 86334

Part No.	End #1
85659-010	O/R Valve "A"
85659-010	O/R Valve "B"
85659-010	O/R Valve Tube "A"
85659-010	O/R Valve Tube "B"

WATER PUMP - 86400

Part No.	End #1
85657-021	Agitator Valve "PB"

REVISION:



**TRAILER MOUNTED PUMP MODEL B20
CONTROL PANEL
ELECTRICAL COMPONENTS (1 OF 2)**

SCMTC

FIGURE 06
PAGE 06

Code	Description	Part No.	Qty.	Location
SWITCHES				
1S1	Key Switch		1	Control Panel
2S2	Toggle Switch, Horn		1	Control Panel
3S3	Toggle Switch, Local/Remote		1	Control Panel
3S4	Toggle Switch, Pump On/Reverse		1	Control Panel
3S5	Toggle Switch, Test A/B		1	Control Panel
3S6	E-Stop Switch		1	Control Panel
	Contact Block, 1NC for 3S6		1	Control Panel
3S7	E-Stop Switch		1	Remote Control
	Contact Block, 1NC for 3S7		1	Remote Control
3S8	Toggle Switch, Horn		1	Remote Control
3S9	Toggle Switch, Pump On/Reverse		1	Remote Control
RELAYS				
1K1	Relay, Engine Start	85348	1	Engine
LIGHTS				
1L1	Light, Green, Control On	85355	1	Control Panel
1L2	Light, Red, Oil Temperature	73775	1	Control Panel
1L3	Light, Red, Coolant Temperature	73775	1	Control Panel
1L4	Light, Red, Oil Pressure	73775	1	Control Panel
1L5	Light, Red, Alternator	73775	1	Control Panel
	Bulb for 1L2, 1L3, 1L4, 1L5	72022	4	Control Panel
2L6	Bulb, E-Stop	85344	1	Control Panel
2L7	Light, Green, Local	85355	1	Control Panel
3L8	Light, Yellow, Remote	85356	1	Control Panel
3L9	Light, Green, Pump On	85355	1	Control Panel
3L10	Light, Green, Reverse	85355	1	Control Panel
3L11	Bulb, E-Stop	85344	1	Remote Control
3L12	Light, Green, Pump On	85355	1	Remote Control
GAUGES				
1G1	Hour Meter	74240	1	Control Panel
1G2	Tachometer	78687	1	Control Panel
1G3	Coolant Temperature Gauge	78203	1	Control Panel

REVISION:



**TRAILER MOUNTED PUMP MODEL B20
CONTROL PANEL
ELECTRICAL COMPONENTS (2 OF 2)**

SCMTC

FIGURE 06
PAGE 07

Code	Description	Part No.	Qty.	Location	
	FUSES				
1F1	Fuse, 25A	800447	1	Control Panel	
1F2	Fuse, 20A	800448	1	Control Panel	
1F3	Fuse, 5A	90392	1	Control Panel	
2F4	Fuse, 10A	800449	1	Control Panel	
2F5	Fuse, 10A	800449	1	Control Panel	
2F6	Fuse, 5A	90392	1	Control Panel	
2F7	Fuse, 5A	90392	1	Control Panel	
2F8	Fuse, 10A	800449	1	Control Panel	
	Fuse Block, 8 Way	85354	1	Control Panel	
	SOLENOID VALVE COILS				
1Y1	Coil, Fuel Solenoid	Deutz	1	Engine	
1Y2	Coil, Accumulator Bypass	85700	1	S-Tube Manifold	
1Y3	Coil, S-Tube Bypass	85702	1	S-Tube Manifold	
1Y4	Coil, Agitator Bypass	73184	1	Hyd. Tank	
2Y5	Coil, Cylinder "B"	85692	1	S-Tube Manifold	
2Y6	Coil, Cylinder "A"	85692	1	S-Tube Manifold	
2Y7	Coil, S-Tube Shift "A"	85692	1	Pump Manifold	
2Y8	Coil, S-Tube Shift "B"	85692	1	Pump Manifold	
	Plugs for 1Y2 thru 2Y8	74597	7	Manifolds	
	MISCELLANEOUS				
2BB1	Black Box, Pump Control	85334	1	Control Box	
2BB2	Black Box, E-Stop Logic	85596	1	Control Box	
2P1	Proximity Switch, Cyl "B"	77998	1	Water Box	
2P2	Proximity Switch, Cyl "A"	77998	1	Water Box	
2H1	Horn	800347	1	Control Box	
3R1	Resistor, 100 Ohm	72777	1	Remote Control	
	CONNECTORS				
X1	Connector Insert, 24 Pin, Female	78696	1	Control Box	
X1	Connector Base	78697	1	Control Box	
X1	Connector Insert, 24 Pin, Male	78695	1	Harness	
X1	Connector Hood	800424	1	Harness	
X2	Terminal Block	72820	8	Control Box	
X3	Connector Insert, 10 Pin, Female	79963	1	Control Box	
X3	Connector Base	79965	1	Control Box	
X3	Connector Insert, 10 Pin, Male	79964	1	Remote Control	

REVISION:



TRAILER MOUNTED PUMP MODEL B20 CONTROL PANEL ELECTRICAL COMPONENTS

SCMTC

FIGURE 06
PAGE 09

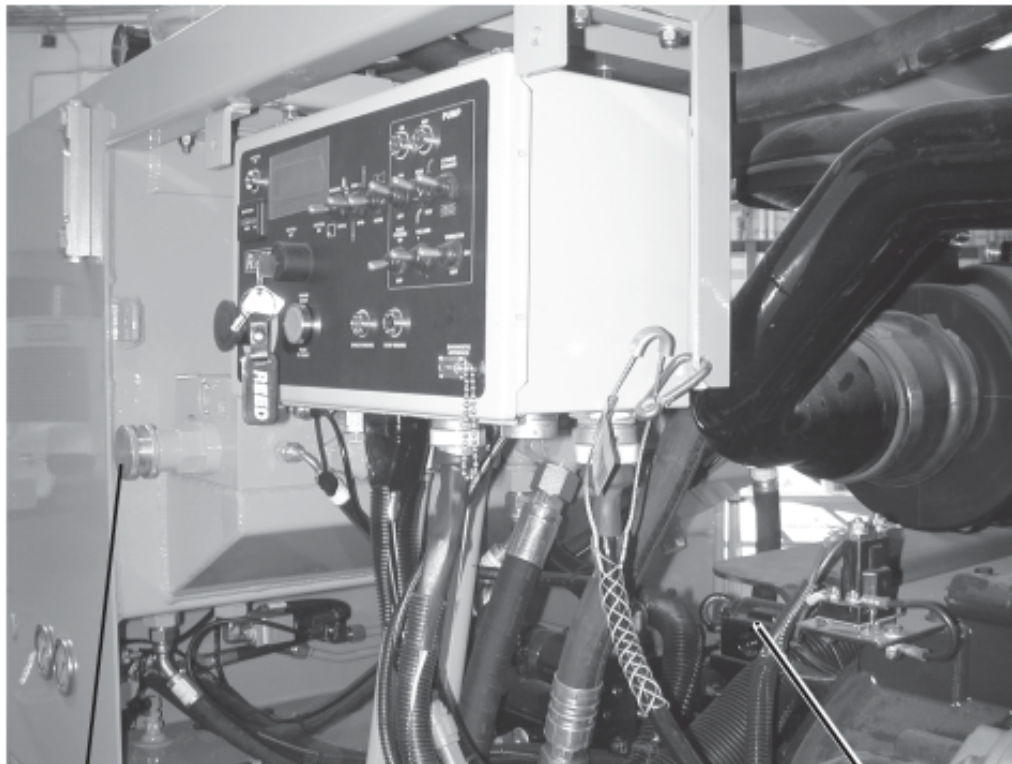
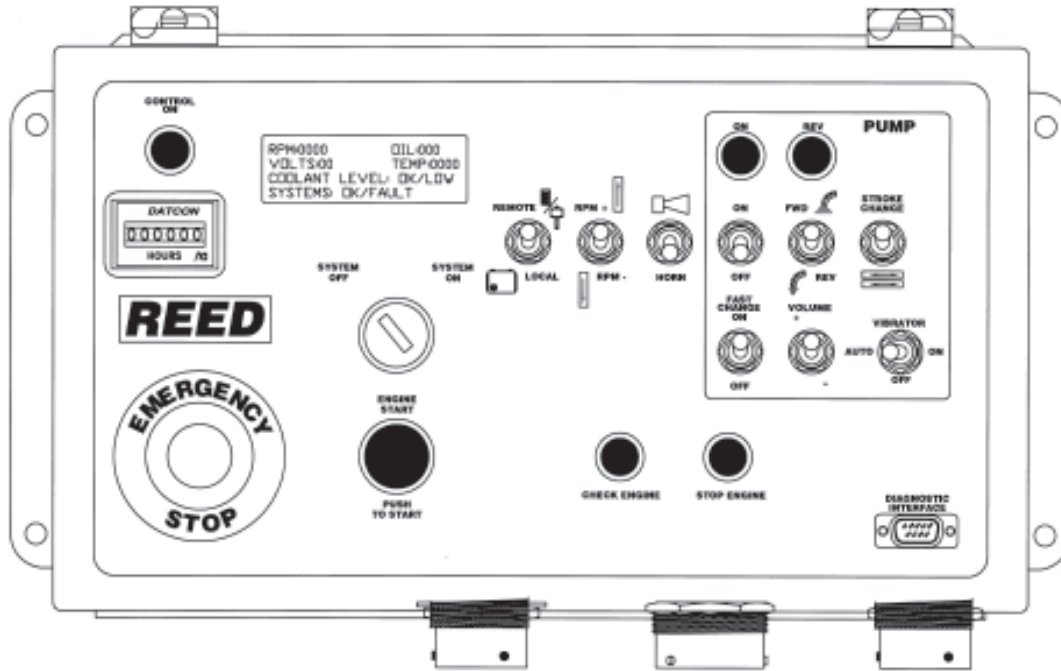

CONTROL BOX WITH COVER REMOVED

VOLUME CONTROL

MAIN HYDRAULIC PUMP

REVISION:



TRAILER MOUNTED PUMP MODEL *B20*
CABLE REMOTE CONTROL
ELECTRICAL COMPONENTS

SCMTC

FIGURE 07
PAGE 10

CONTROL BOX PENDANT - CABLE REMOTE CONTROL UNIT - PN 87347-1

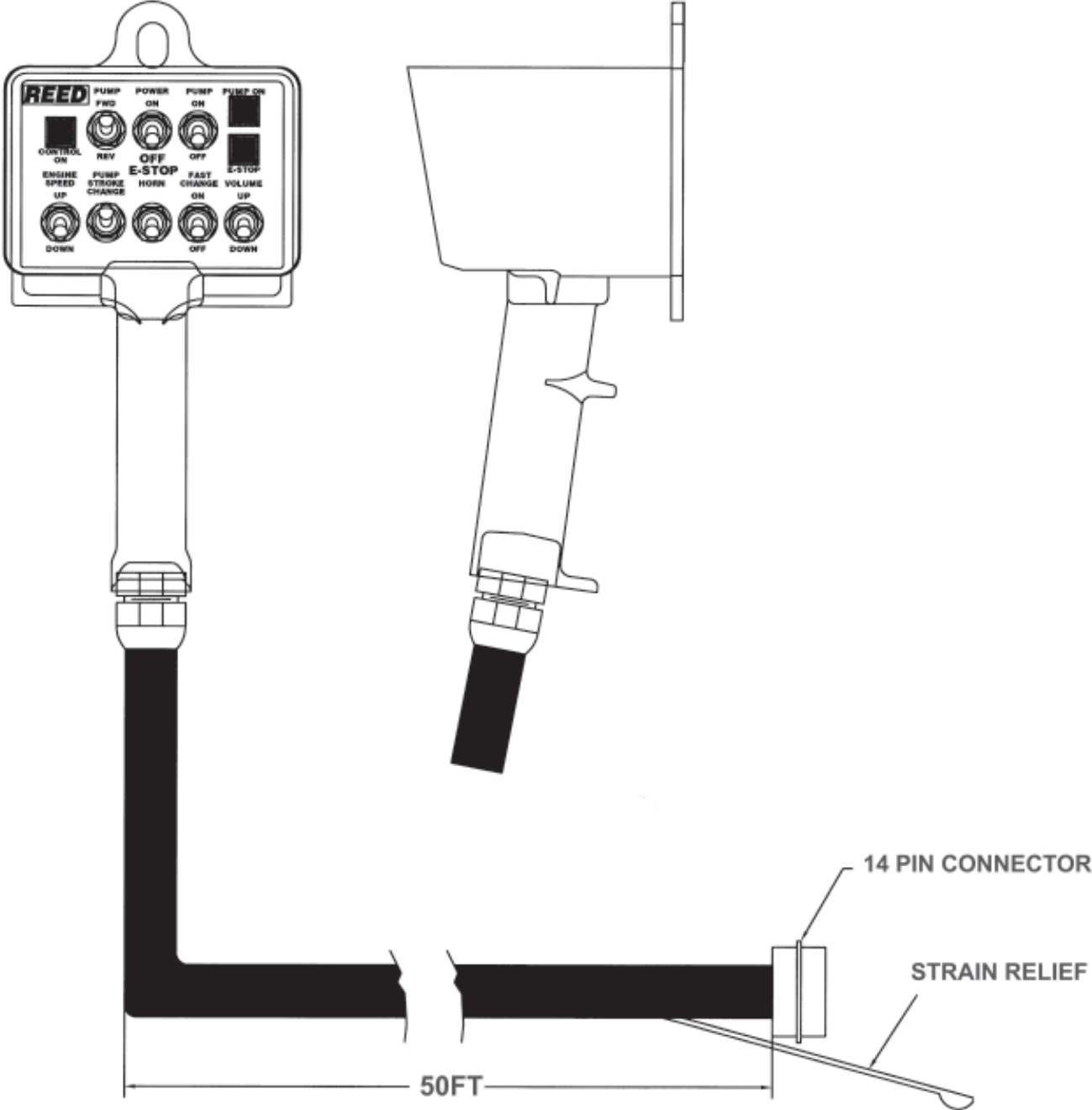

REVISION: