

PRE-OPERATION INSPECTION

The **CONDITION** of the unit prior to start-up is a very **IMPORTANT** factor as it directly affects the operator's safety as well as those around him. It should be a common practice that the operator performs a general inspection of the **REED MODEL B20** before each day's operation.

The purpose of the operator's inspection is to keep the equipment in **PROPER** working condition and to **DETECT** any sign of malfunction during normal operations between scheduled maintenance checks.

DOWNTIME is **COSTLY** and can be prevented by taking a few minutes prior to start-up to do a thorough walk-around inspection. This inspection must be performed each day before the unit is operated. Report any damage or faulty operation immediately. Attach a sign, if need be, at the control panel which states **-----DO NOT OPERATE -----**. Repair any discrepancies before use.

Some major items to be considered for you inspection include the following:

1. OVERALL MACHINE CONDITION

- External structural damage
- Wheel lug nuts missing or loose
- Brake line wiring, connection
- Condition of tires, pits, tears, cuts, inflation
- Decals, placards, warning signs
- Missing, broken or damaged parts
- Remote switch & cable condition
- Gauges, throttle cable

2. HYDRAULIC SYSTEM

- Loose or damaged hoses, tubing, fittings
- Hydraulic leaks

- Hydraulic fluid level
- Cleanliness of fluid, filter condition indicator
- Hydraulic valves and control levers
- Hydraulic cylinders

3. HOPPER

- Grate in place not damaged
- Agitator condition
- Drive motor
- Swing tube connection
- Shift cylinders condition
- Outlet connection



4. ELECTRICAL

- Frayed or broken wires or loose connections
- Condition of switches, lights, connections
- Instruments and gauges - condition

⚠ CAUTION

Defective components, structural damage, missing parts or equipment malfunctions, jeopardize the SAFETY of the operator and other personnel and can cause extensive damage to the machine. A poorly MAINTAINED machine can become the greatest OPERATIONAL HAZARD you may encounter.

GETTING ACQUAINTED (UNIT FAMILIARIZATION)

As previously indicated, it is important from a SAFE operational standpoint that you, the OPERATOR, know your machine. This means the function of each control as to what happens when it is activated, how it might interact with other functions and any limitations, which might exist. A GOOD UNDERSTANDING of the controls and capabilities will enhance operation and assure maximum operating and efficiency and SAFETY.

These next few pages will assist you in GETTING ACQUAINTED with the MODEL B20 concrete pump. Carefully study these.

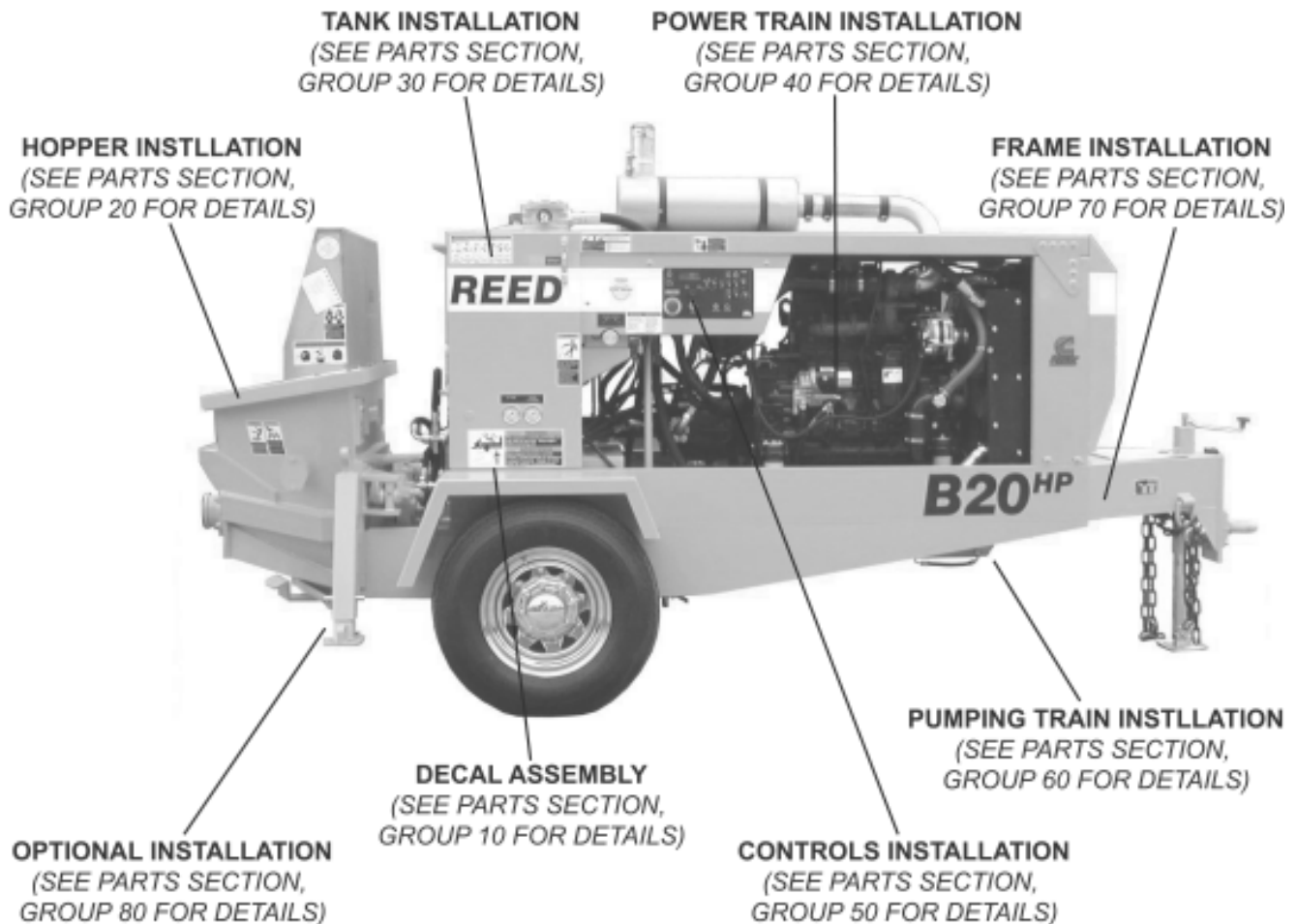



REED MODEL: B20 TRAILER CONCRETE PUMP

CONTROL FAMILIARIZATION

The controls for operation of the **MODEL B20** can be found and are located on the right (curb) side of the machine. A control box is provided and contains all the main function instruments, switches, and indicators. Hydraulic gauges and throttle control are on lower portion of hydraulic tank. The volume control is adjacent to the main control. Each location or panel is dedicated to the operation of certain functions. These are noted herein:

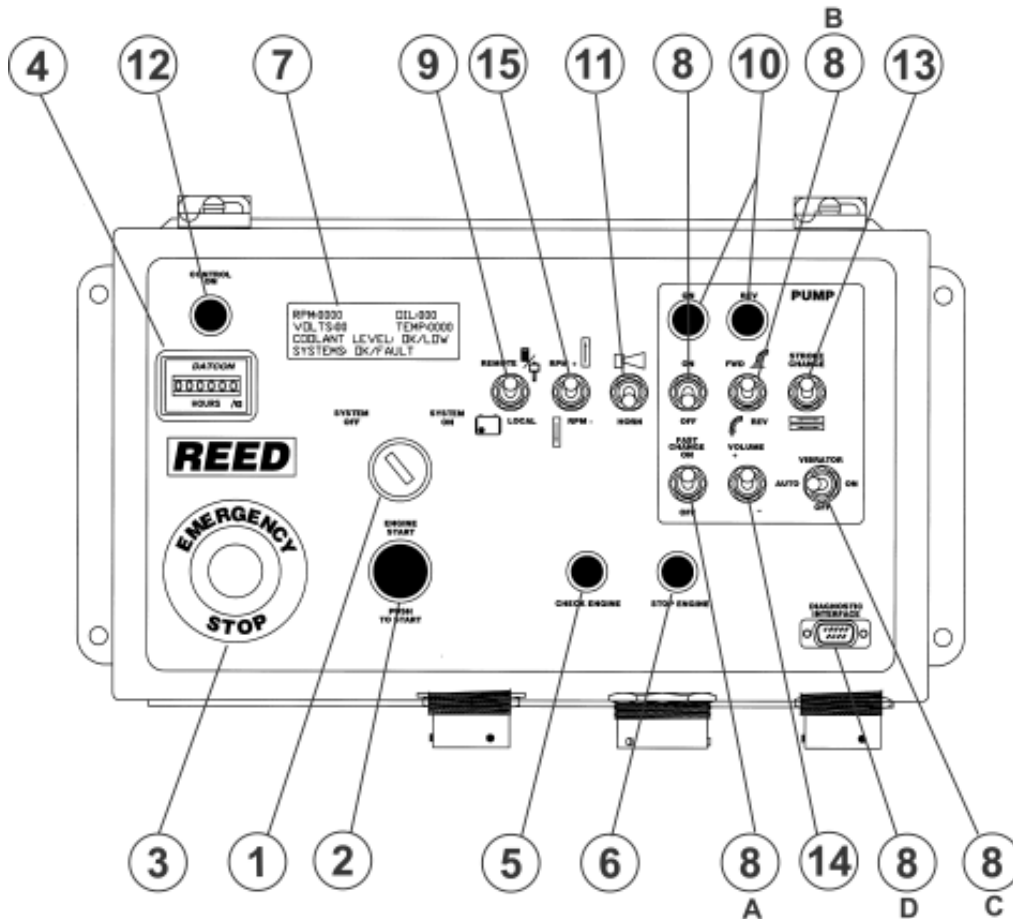

1. SYSTEM POWER SWITCH

This is a two (2) position key switch and is used to control the engine. Turn key to **SYSTEM ON** position to energize the electrical circuit. Shut down the engine by turning the key to **SYSTEM OFF** position.

2. ENGINE START SWITCH

The **GREEN BUTTON** is a pushbutton switch. By pushing the button, along with the key switch in the **SYSTEM ON** position, will start the engine.

3. EMERGENCY STOP

This is an emergency switch and is used to shut down the pump in an emergency situation. It is of the push-pull type. Depress **PUSH** knob in to **STOP** operation. **PULL** knob out to **REACTIVATE** system. **NOTE - The HORN/RESET must be switched one time to reset pump operation.**

4. HOUR METER

This instrument is used to record the number of hours the electric system has been activated. The hour meter becomes operational when the ignition key is **ON**.

5. CHECK ENGINE (YELLOW LIGHT)

This light, when lit, is indicating to check the diesel engine for possible problems.

6. STOP ENGINE (RED LIGHT)

This light, when lit, indicates to **STOP ENGINE** immediately, it requires attention.

7. DIGITAL DISPLAY

The control panel's digital display indicates the following areas: The engine **RPM**, the **OIL PRESSURE**, the **VOLTS**, **ENGINE TEMP**, **COOLANT LEVEL** and the status of the **SYSTEMS**.

8. PUMP POWER SWITCH (GREEN LIGHT)

This is a two (2) position toggle switch and is used to control pump **ON/OFF** feature.

8A FAST CHANGE SWITCH (C-SERIES ONLY closed loop hydraulic system)

This is a two (2) position toggle switch and is used to control **FAST CHANGE** feature, that changes the hydraulic pump to run smoother in certain applications.

8B PUMP DIRECTION SWITCH

This is a three (3) position toggle switch and is used to control the cycle direction of the concrete pump. **CENTER** position of toggle is **PUMP-OFF**. Move toggle to **UP** position to activate **PUMP-ON** and **FORWARD** cycling. Move toggle in the **DOWN** position to **REVERSE** cycling.

8C VIBRATOR (OPTION-GOES ON HOPPER GRATE)

This is a three (3) position toggle switch and is used to control the vibrator.

8D DIAGNOSTIC INTERFACE (FACTORY AND FACTORY DEALERS ONLY)

This is a **RS-232** computer port that is used for factory system settings and system diagnostic analysis.

9. CONTROL SWITCH

This is a two (2) position toggle switch and is used to select the pump control location. Move toggle to **LOCAL** to enable operation of concrete pump from main stationary control panel. Move toggle to **REMOTE** for operation using the remote control.

10. INDICATOR LIGHTS RELATED TO THE PUMP (GREEN LIGHT)

These green lights, located above and below the switches are used, when lit, to indicate the position of the toggles.

11. HORN/RESET

This is a momentary toggle switch and is used to reactivate the control and pump circuit after machine has been shut down using the **EMERGENCY STOP** switch. Once the emergency stop has been depressed it will be necessary to pull out switch and move toggle of **HORN** switch momentarily to **RESET** position.

12. CONTROL ON INDICATOR LIGHT (GREEN LIGHT)

This is a green indicator light, when lit denotes control circuit is energized

13. STROKE CHANGE SWITCH

This switch is a two (2) position spring return switch and has two functions. One is a momentary toggle to change stroke from one side to the other to help clear a possible line plug. The other function is when the switch is held **DOWN** and allow for the end of stroke. High pressure check or in the instance of equalizing the stroking pistons. The allowance for the spring return sets the machine back in the forward stroke.

**14. VOLUME CONTROL
(C-SERIES ONLY closed loop hydraulic system)**

This control is installed on the discharge port of the main hydraulic pump. It is used to adjust volume **OUTPUT** of the material cylinders which in turn is controlled by the hydraulic pump. Flipping toggle switch **UPWARD** will **INCREASE** volume, flipping toggle switch **DOWNWARD** will **DECREASE** volume.

15. THROTTLE CONTROL

This switch is a three (3) position spring centered toggle switch. It is used for the purpose of adjusting the engine's **RPM**. Toggle **UP** to **INCREASE** engine speed. Toggle **DOWN** to **DECREASE** the speed of the diesel engine. The speed of the engine will be retained as set until **RESET**.

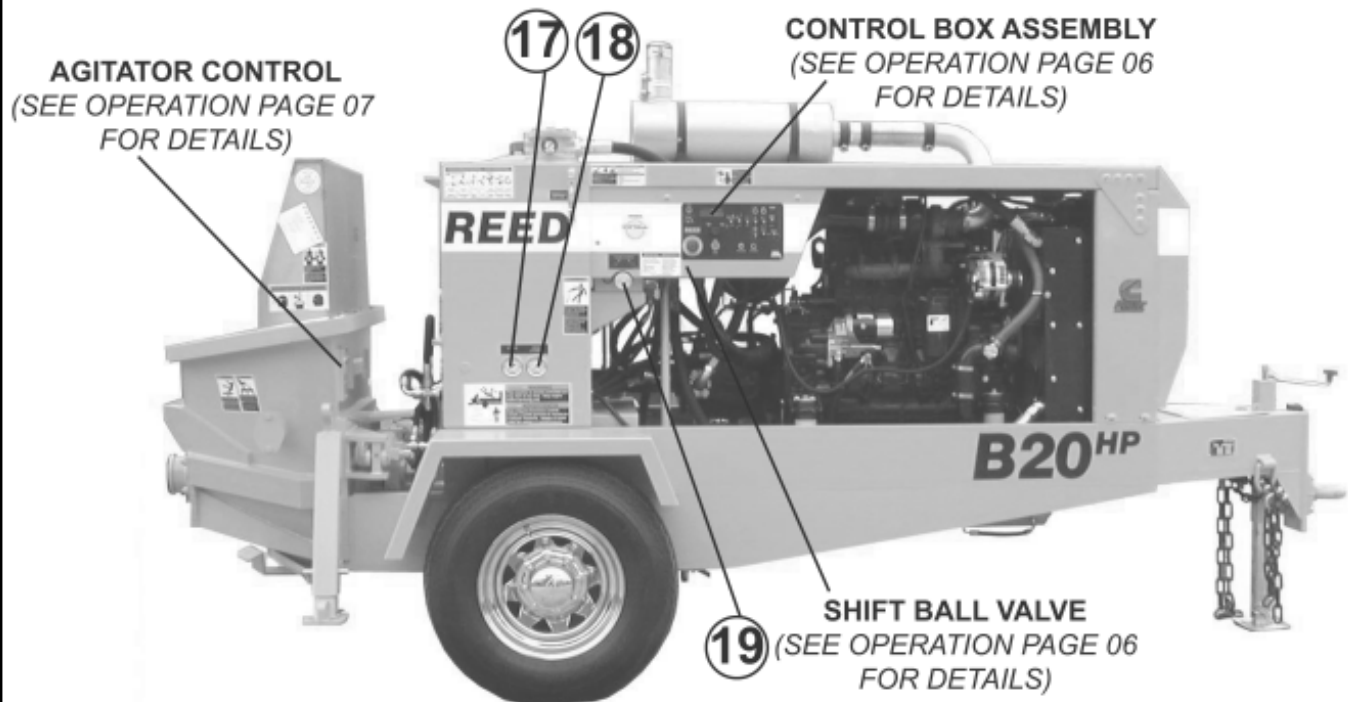

16. STROKE COUNTER (OPTION- NOT SHOWN)

This digital display indicator is used to indicate the amount of strokes per minute the concrete pump is producing.

17. PRESSURE GAUGE - 6000 PSI

This hydraulic pressure gauge is used to indicate the main system hydraulic pressure being applied to the hydraulic cylinder pistons of **CYL A OR CYL B** on the forward stroke.

18. PRESSURE GAUGE - 3000 PSI

This hydraulic pressure gauge is used to indicate the hydraulic pressure of the swing tube shift accumulator circuit.

19. VOLUME CONTROL

This control is installed adjacent to the main panel, just forward of the hydraulic tank. It is used to adjust volume output of the material cylinders which in turn is controlled by the output of the hydraulic pump. Turning knob **COUNTER-CLOCKWISE** will **INCREASE** volume, turning knob **CLOCKWISE** will **DECREASE** volume.

⚠ WARNING

**DO NOT VARY THE PUMP OUTPUT BY
VARYING ENGINE SPEED.**

20. AGITATOR CONTROL

The agitator or remixer function is controlled by a manually operated single spool directional control valve. The valve is used to control **ON-OFF** function as well as the rotation direction of the hydraulic motor. With lever in **CENTER** position, the hydraulic flow to the motor is **OFF**.



21. OUTRIGGER CONTROL

As part of the same valve bank as the agitator, the two (2) additional valve sections are used to control the outriggers. One lever controls the right outrigger, the other controls the left outrigger. Lever in CENTER position, the flow is OFF.

22. WATER PUMP CONTROL - OPTION

This option is operated from the auxiliary circuit. It utilizes a single spool manual directional valve to control the operation of the hydraulic motor. The motor is used to drive the water pump.

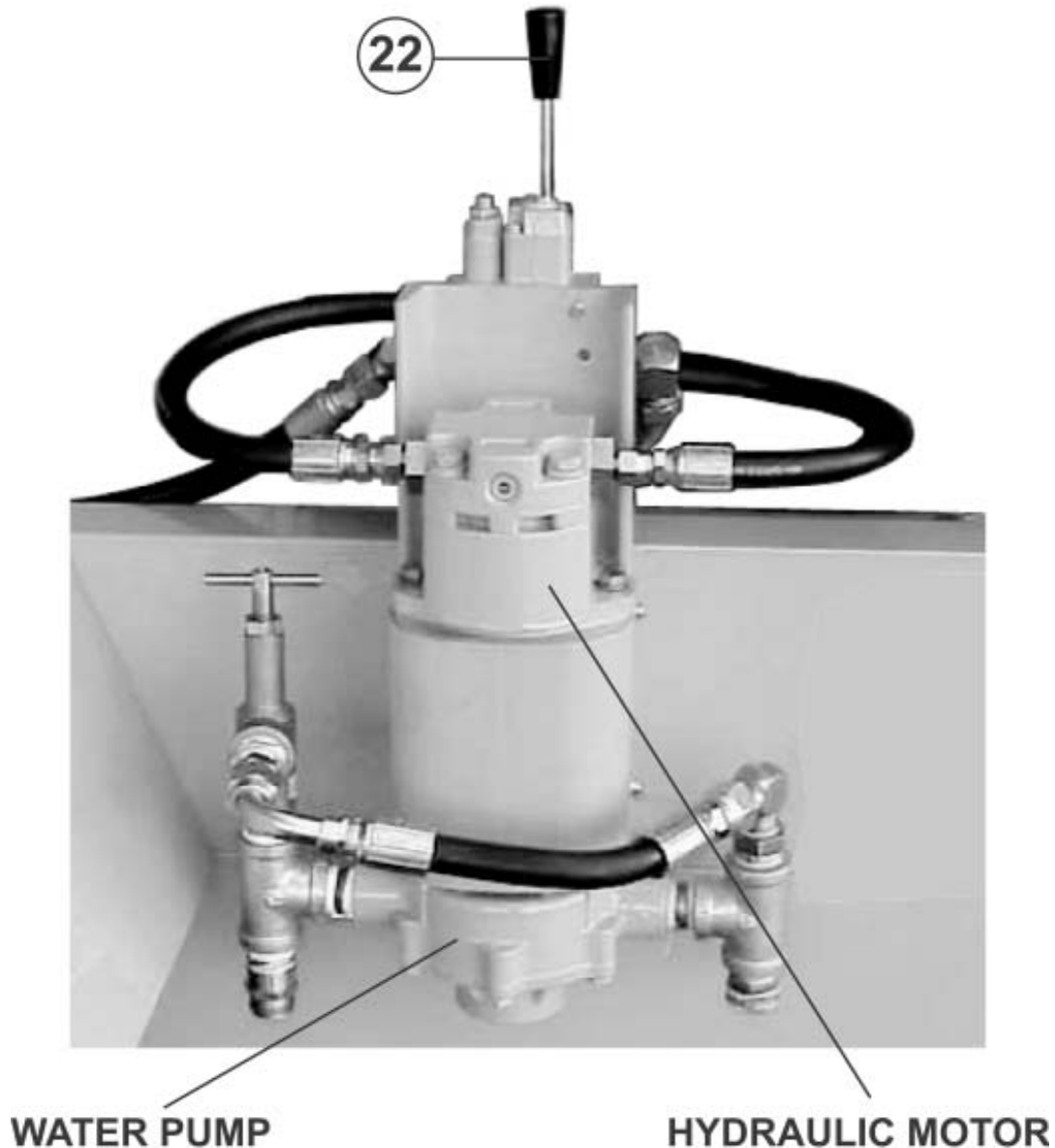

23. SHIFT BALL VALVE

This control is located on the swing circuit hydraulic manifold. It is a manual ball valve and is used to control the speed of the S-tube shift. For a hard fast shift, place lever of ball valve in a vertical (12 o'clock) position. This places the valve fully open and allows the flow to bypass the restrictive orifice. This valve position may be used when a harsh material mix is being pumped requiring more power in shifting the S-tube.

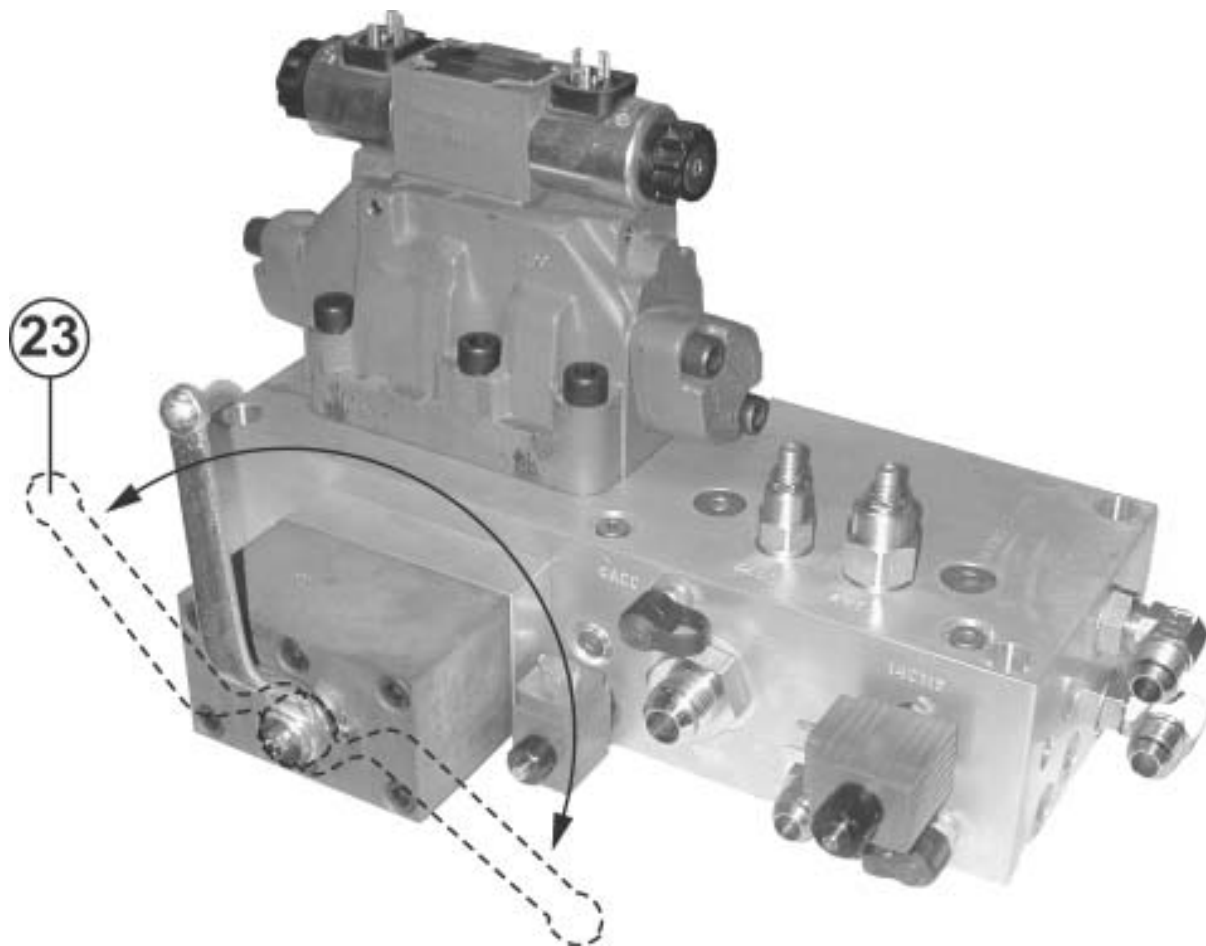

For an easier, slower shift, move the ball valve lever to the 3 o'clock position. This closes the ball valve and directs the fluid through the orifice. This position may be used when a slurry is being pumped or when the machine is being cleaned out.

This unit can be operated with lever in any position from 12 o'clock to 3 o'clock. Eventually, experience will dictate what setting is best.

REMOTE CONTROL FAMILIARIZATION

A remote control pistol grip console is provided and is used to enable the operation of the concrete pump away from the immediate vicinity of the unit. The remote is equipped with an umbilical cord that plugs into the side of the main control box. The console consists of the following functions.

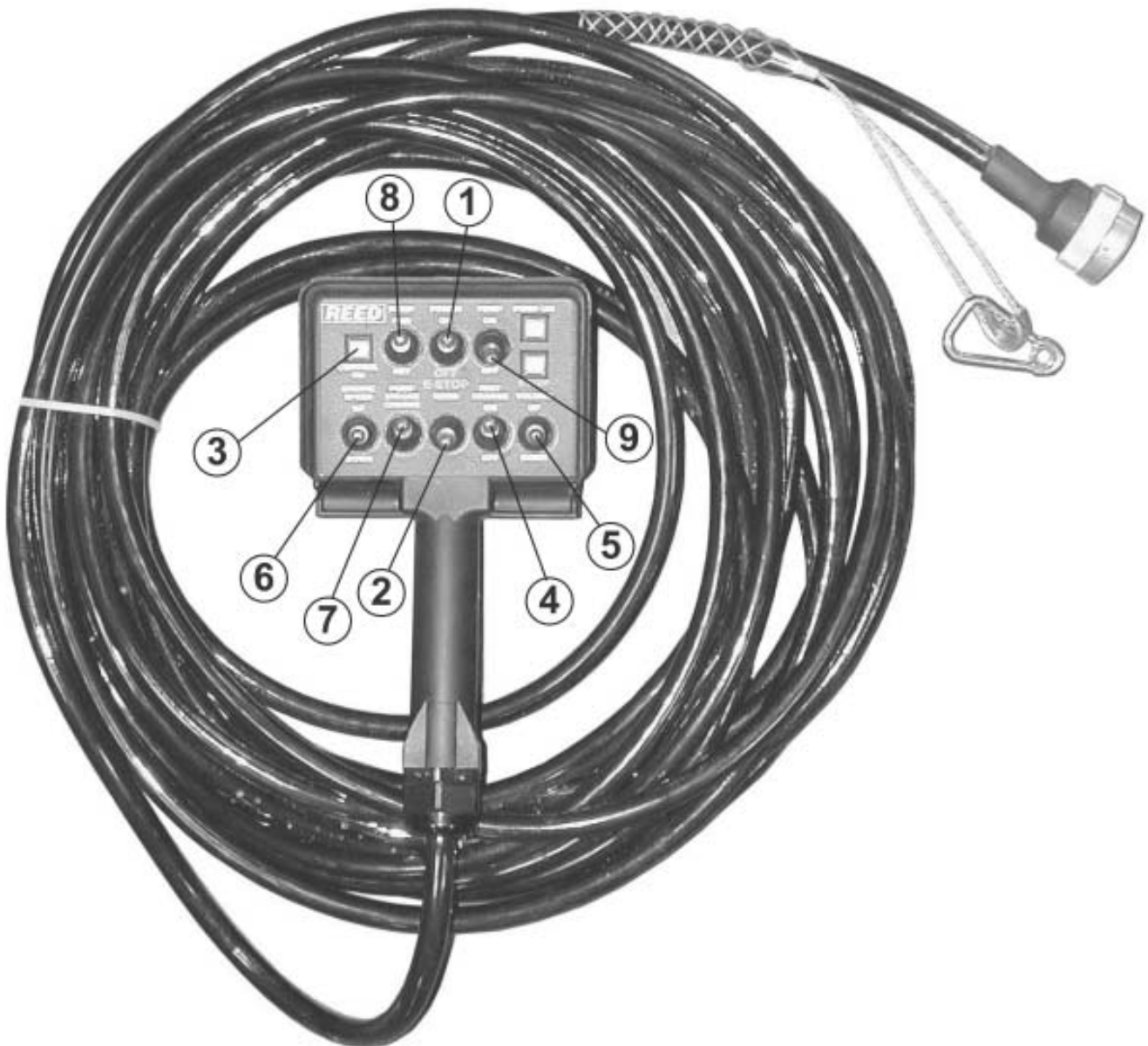



REED MODEL: B20 TRAILER CONCRETE PUMP

OPER.

PAGE 11

1. EMERGENCY STOP SWITCH

This is an emergency switch and is used to shut down the pump in an emergency situation. It is of the push-pull type. Depress, **PUSH**, knob in to **STOP** operation. In this position, knob will light. **PULL** knob **OUT** to **REACTIVATE** system.

2. HORN/RESET

This is a momentary toggle switch and is used to activate the control and pump circuit after the machine has been shut down using the **EMERGENCY STOP** switch. Once the emergency stop has been depressed, it will be necessary to pull out switch and move toggle of **HORN** switch momentarily to **RESET** position.

3. INDICATOR LIGHT

This green indicator light will be lit when remote circuit is energized.

4. PUMP SWITCH

This is a three (3) position toggle switch and is use to control the cycle direction of the concrete pump. **CENTER** position of toggle is **PUMP-OFF**. Move toggle to **DOWN** position to turn pump **ON** for **FORWARD** cycle. Move toggle in **UP** position for **REVERSE** cycling.

5. VOLUME CONTROL

This control is installed on the discharge port of the main hydraulic pump. It is used to adjust volume **OUTPUT** of the material cylinders which in turn is controlled by the hydraulic pump. Flipping toggle switch **UPWARD** will **INCREASE** volume, flipping toggle switch **DOWNWARD** will **DECREASE** volume.

6. THROTTLE CONTROL(ENGINE SPEED)

This is a three (3) position spring centered switch and is used to adjust the engine **RPM**. Toggle **UP** to **INCREASE** engine speed. Toggle **DOWN** to **DECREASE**

7. STROKE CHANGE SWITCH

This switch is a two (2) position spring return switch and has two functions. One is a momentary toggle to change stroke from one side to the other to help clear a possible line plug. The other function is hen the swicdth is held **DOWN** and allow for the end of stroke. High pressure check or in the instance of equalizing the stroking pistons. The allowance fo the spring return sets the machine back in the forward stroke.

8. PUMP DIRECTION SWITCH

This is a three (3) position toggle switch and is used to control the cycle direction of the concrete pump. **CENTER** position of toggle is **PUMP-OFF**. Move toggle to **UP** position to activate **PUMP-ON** and **FORWARD** cycling. Move toggle in the **DOWN** position to **REVERSE** cycling.

9. PUMP POWER SWITCH (GREEN LIGHT)

This is a two (2) position toggle switch and is used to control pump **ON/OFF** feature.

REVISION:

RADIO REMOTE CONTROL FAMILIARIZATION

A wireless radio remote control unit may be used to enable operation of the concrete pump away from the immediate vicinity of the unit. The complete unit consists of a hand held transmitter and a receiver which is within the control panel.



1. E-STOP SWITCH

This is an emergency switch and is used to shut down the pump in an emergency situation. **DEPRESS RED** switch to **STOP** operation. **TWIST RED** button to clockwise to reactivate system.

2. POWER LIGHT

This indicator light is used to depict when light is lit that the transmitter is ready for use.



REED MODEL: B20 TRAILER CONCRETE PUMP

OPER.

PAGE 13

3. PUMP SWITCH

This switch is used to control the operation of the concrete pump. **PUSH** top part of switch to turn pump **ON**, start cycling. **PUSH** bottom of switch to turn pump **OFF**.

4. PUMP DIRECTION SWITCH

This switch is used to select the pump direction of the unit. Momentarily press switch to **FORWARD**, pump will cycle normally pumping material out discharge. Press switch to **REVERSE**, pump draws material back into hopper.

5. HORN SWITCH

This switch is used to activate the control and pump circuit after the machine has been shut down using E-Stop. Once E-Stop has been depressed, it will be necessary to depress **ON** button. Depress **HORN** switch to reactivate system.

6. THROTTLE CONTROL

A single toggle switch controls the speed of the engine. Move the toggle switch **UP**, to **INCREASE** engine speed. Moving the switch, **DOWN** to **DECREASE** the speed of the engine. The speed of engine will retained as set, until it is reset.

7. STROKE CHANGE SWITCH

Refer to **OPER. SECTION** page 05 for switch's function.

8. VOLUME CONTROL

Refer to **OPER. SECTION** page 05 for switch's function

9. RED BATTERY INDICATOR (Located at top of remote transmitter)

This red **BATTERY** indicator turns on momentarily when toggles are pressed and turns off if the battery is good.

This indicator will remain on when the battery voltage is low. There is enough power in the battery for about 15 minutes of operation after the light remains on. When this time is up, the red battery will turn off and the transmitter will no longer function properly until the battery has been changed. The transmitter is powered by a 9 volt alkaline battery. The operation time of the battery is determined by both frequency and duration of use.

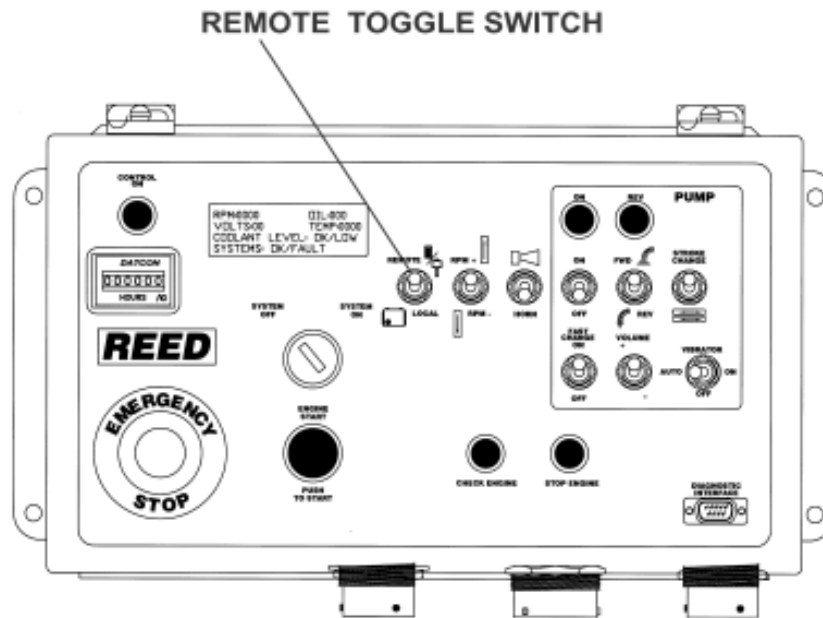

RADIO REMOTE OPERATION

(REFER TO TEACH PROCEDURES IN SCHEMATICS SECTION OF THIS MANUAL)

Before proceeding to start-up and operate the radio remote control, make sure it is safe to do so. Make sure the same safety precautions normally required for safe pump operation are adhered to.

- Place control switch on main panel to **REMOTE** position. The receiver **POWER** light should be lit.
- Press the transmitter **ON** switch. The **POWER** light on transmitter should slowly flash and the receiver **ACTIVE** light should be lit.
- When ready to cycle pump, press the transmitter switch to **PUMP**, and the **DIRECTION** switch to **FORWARD**. The receiver **PUMP** light should be lit. To stop the pump momentarily press the transmitter switch to **STOP**. **PUMP LED** should go out.
- To change the pump direction to reverse, press the **REVERSE** switch. The reverse **LED** should light.
- Press transmitter **OFF** switch to deactivate radio remote transmitter.

WARNING

Do not leave the transmitter unattended while pump engine is operating.



REED MODEL: B20 TRAILER CONCRETE PUMP

OPER.

PAGE 15

TOWING THE TRAILER

The **REED MODEL B20** material pump although small in stature as compared to larger pumps or construction type equipment, requires the same care and attention in transporting as does the larger heavier equipment. At no time should this be overlooked.

The **REED MODEL B20** is equipped with a torsion bar single type axle, electric brakes, and standard tail lights. It is capable of being towed by a truck at a highway speed up to **55 MPH (88 KM/HR) MAXIMUM**, depending on road conditions. **THIS SHOULD NOT BE EXCEEDED.**

PREPARE THE UNIT FOR TOWING AS FOLLOWS:

- **For units equipped with a pintle ring**, install over pintle hook and close safety clasp. Insert pin to secure lock safety clasp.
- **For units equipped with a ball hitch**, secure hitch on ball and lock in place. Check that ball has been completely inserted into coupler ball socket and ball clamp is closed around the underside of the tow ball and yoke and lever is in a closed position.
- Always attach the **SAFETY CHAINS** to towing vehicle and attach the break away cable.
- Connect trailer electrical cable to truck connection to establish trailer brake circuit and lighting. Electronic brake control necessary unless equipped with hydraulic surge brakes. Check that lighting is operational.
- Raise outrigger legs and secure in place with retainer pin.
- Make sure that hopper clean-out door is securely closed.
- Fully raise front jackleg and lock handle.
- Check the tires for proper inflation pressure and inspect for any cuts and excessive wear.
- Survey underside of pump and trailer to look for other possible obstructions.

REVISION:

⚠ WARNING

*Towing trailers at excessive speeds is **DANGEROUS**. Some trailers may weigh as much or more than the vehicle doing the towing, and can affect the control of the towing vehicle causing an **OVERTURN** condition. This situation can arise from excessive speed or rapid braking. Therefore, always maintain a sufficient distance for safe braking.*

TOWING TIPS:

- **Never travel with concrete in hopper.** The trailer pump is not designed to be towed with this extra weight.
- Remove all delivery lines from hopper outlet.
- Travel only as fast as conditions allow. **DO NOT EXCEED 55 MPH (88 KM/HR).**
- Always leave sufficient distance between you and the vehicle ahead to allow **SAFE BRAKING**.
- Reduce speed at dips, bumps and rough road areas.

If trailer begins to sway or swerve side to side, ease off of accelerator to slow down. **DO NOT JAM ON BRAKES.** Gently touch brake pedal intermittently to come to a stop. Check to determine cause of sway. Check hitch.





REED MODEL: B20 TRAILER CONCRETE PUMP

OPERATION INSTRUCTIONS

Having **READ** and **UNDERSTOOD** the previous pages on **SAFETY** and **CONTROL FAMILIARIZATION** you are now in a position to learn how to operate the unit. If you have not **READ** the previous pages we suggest you do so before **PROCEEDING**.

CAUTION

*For your own **SAFETY** and others around you it is your **RESPONSIBILITY** to insure the unit is in proper working condition. Check out the unit by using the **PRE-OPERATION INSPECTION** notes previously identified.*

WARNING

OBSERVE ALL SAFETY PRECAUTIONS WHILE OPERATING THIS MACHINE.

SELECTION AND SETUP AT JOB SITE

Your first and primary concern when arriving at the job site is to insure the machine can be safely operated and it will afford the maximum production efficiency without jeopardizing safety.

- The machine should be located on as level ground as is possible.
- Lower the front leg jack to ground and if necessary place wooden blocking under the jack pad.
- Lower rear outriggers and pin in place. If necessary, place additional blocking under the pads.
- Lower and apply pressure to the front jack on the ground and if necessary place wooden blocking under the jack pad. This will transfer weight to the outrigger legs.

NOTE

DAMAGE WILL OCCUR IF OUTRIGGERS ARE NOT USED. WARRANTY WILL NOT BE HONORED IN THIS SITUATION!

REED**REED MODEL: B20
TRAILER CONCRETE PUMP**

- Keep a sufficient distance away from slopes, pits, trenches, and excavations that could break away.
- Make every attempt to setup as near as possible to placement site. The shorter the pumping distance the greater the material delivery.

When the site for the operation has been selected proceed to setup unit for pumping.

- Disconnect safety chain, electrical cable and hitch from towing vehicle.

DELIVERY SYSTEM SUGGESTIONS

The delivery system is an arrangement of those components used from the pump discharge to the placement site. This could consist of rubberized material hose, steel piping, clamps, couplers, and reducers. How this delivery system is setup, what components are used will greatly affect the end result of efficient and productive concrete pumping. The following suggestions are offered to assist in achieving your objective and for your consideration in laying out the delivery line.

- Use the most direct line as is feasible from the concrete pump to the placement area.
- Setup the delivery line using a minimum of rubber hose. Rubber hose offers three (3) times the resistance to the flow of concrete as compared to steel pipe.
- Concrete will flow with less back pressure through pipe than through hose.
- Minimize the use of bends in the hose. This requires more pumping pressure.
- Place the hoses or pipe to the farthest placement point from the hopper discharge outlet **FIRST**. It is easier to remove lines that it is to add as the pumping operation takes place.
- The steel pipe, elbows, reducers and hoses should be equipped with heavy-duty ends. These ends have a higher-pressure capability than the standard ends.
- Only connect together couplings or clamps that are clean and seals that will retain the slurry in the delivery line. Dirty couplings **LEAK** and when pressurized the leaking of water will inevitable cause blockage.
- **DO NOT USE** any worn or damaged hoses, pipes or couplings.

- If the delivery line will cross rebar, support must be considered for the pipe so that it does not contact the rebar mat.
- For best pumping results it is important to size the inside diameter of the pipe or hose to that of the size of the aggregate in the concrete to be pumped. The general rule is the inside diameter of the pump or hose shall be 3 to 4 times the size of the largest aggregate in the mix. As an example:
 1. Aggregate classified as 1-1/2 inch (38 mm) rock, 8 to 10% maximum content by weight requires a 5 inch (127 mm) diameter concrete delivery system.
 2. Aggregate classified a 1 inch (25 mm) rock, 10 to 15% maximum content by weight, requires a 4 inch (100 mm) diameter concrete delivery system.
 3. Aggregate classified as 3/4 inch (19 mm) or smaller rock, 10 to 15% maximum content by weight, requires a 3 inch (76 mm) diameter concrete delivery system.
- For vertical concrete delivery system, the vertical pipe line should be anchored to the building or other supporting structures every 10 ft (3 m) of height.

PRE-PUMPING PREPARATIONS

Again we **REMAND** you to make sure the machine is in **PROPER WORKING CONDITION**. One of the worst and possible the most expensive situation to encounter is to begin pumping and have a failure occur due to **NEGLIGENCE** of a thorough pre-operation inspection.

STARTING THE PUMP

Before starting diesel engine, check the position of the following control and functions:

- That the **PUMP CYCLE** switch is **OFF**
- That the **VOLUME CONTROL** is **CLOSED**, screwed in.
- That the **AGITATOR** control lever is in **OFF** position.
- Check flush box is filled that sufficient lubrication oil or water exists. Replace cover.

REED**REED MODEL: B20
TRAILER CONCRETE PUMP**

When you have completed the above checks, the unit is ready for start-up.

- At the main control panel, turn key switch and start engine. When engine starts, release key.
- Check the engine indicator lights of alternator, oil temperature, low coolant and low oil.
- Check that **CONTROL LOCATION** switch is in **LOCAL** position.
- Allow a few minutes for engine to warm up.
- Increase engine RPM by adjusting **THROTTLE** control to desired engine speed as indicated on tachometer.
- Ensure **EMERGENCY STOP** switch is pulled out then move toggle of **HORN** switch to **RESET** to activate system.
- Check the swing tube pressure gauge (300 PSI/210 BAR gauge) this it is operational. Gauge should read approximately 2000 PSI (140 BAR).
- Pressure gauge for **DRIVE CYLINDERS** (6000 PSI/420 BAR) will only indicate pressure when pump switch in **ON**. Pumping pressure will vary depending on hose size, length, material slump, pumping speed, etc. .
- **DO NOT CYCLE PUMP** unless water or material has been placed in the hopper.
- To cycle pump adjust **THROTTLE** and **VOLUME** control to desired setting.

Place pump switch to **ON** position. The hydraulic drive and material cylinders will now cycle.

- Turn pump switch **OFF** to stop cycling.

⚠ CAUTION

*At **START-UP, ALWAYS OPERATE AT LOW SPEED AND LOW VOLUME** until proper operation has been assured.*

PRIMING THE PUMP SYSTEM

Before proceeding to cycle and pump concrete material it will be necessary to prime the pump system and delivery lines. This operation consists of pumping a coating of lubrication grout through the S-tube and delivery lines to enable the regular concrete mix to flow smoothly.

The grout use for priming and lubrication should consist of two (2) parts sand and one (1) part cement and mixed to a consistency of thick soup. This will coat the delivery line ahead of the actual material mix and will assist in preventing the possibility of packing when the line is filled with regular mix

How much grout will be needed depends on the length of the delivery line as well as the material being pumped. Experience will eventually indicate the amount to be required.

- Using a water hose wet down the inside of the hopper with about one (1) gallon of water.
- When the concrete from the ready-mix truck is ready to be placed in the hopper, pour the grout into hopper.
- Adjust **THROTTLE** to **FULL RPM**.
- At pump panel adjust **VOLUME** control to about 1/2 open and turn **PUMP ON**.
- As the slurry is being pumped out begin charging, pouring concrete from the truck into the hopper.
- Engage the **AGITATOR** using appropriate control.
- Continue to pump until a steady flow is discharged from end of delivery line.
- Once this point has been reached, the **VOLUME** control can be adjusted to the desired concrete output.
- During the pumping operation observe the 6000 PSI drive cylinderhydraulic gauge. Be alert to unactuated sudden changes in pressure, high or low.
- The **S-TUBE** gauge should read approximately 2000 PSI just prior to the shifting of the S-tube. As shift is made gauge will quickly lose pressure then re-charge to 2000 PSI..
- To check pumping pressure, actuate **TEST** switch to either **CYL "A"** or **CYL "B"** position. Hold toggle until piston bottoms out. Read pressure on 6000 PSI gauge.



**REED MODEL: B20
TRAILER CONCRETE PUMP**

NOTE

The pressure by which the concrete is being pumped is based on the ratio between the hydraulic cylinder and the material cylinders and that is divided into the hydraulic pressure being applied to the drive cylinders.

In this instance the ratio is **2.12** for the Model **B20** and a **1.52** ratio for the Model **B20HP**(piston side) and the concrete pressure is calculated as follows:

SYSTEM GAUGE-PSI	CONCRETE PRESSURE PSI
1000	472/658
2000	943/1316
3000	1415/1974
3500	1651/2303
4000	1887/2632

On the other hand the hydraulic pressure being applied to the drive cylinders is controlled by the amount the **VOLUME** control is opened. When turned to the **FULL OPEN** position this will produce approximately 4000 PSI on gauge.

PUMPING TIPS AND PRECAUTIONS

Your **SAFETY** is our utmost **CONCERN** and it is your **RESPONSIBILITY** to operate the equipment in a **SAFE** manner. The following **TIPS** and **PRECAUTIONS** are offered as **AWARENESS** facts and should be **OBSERVED** for proper safe operation.

- Always maintain the material level in the hopper to no less than the height of the remixer shaft height or 1/2 full. This is **IMPORTANT** otherwise air will be sucked into the material cylinders and the continuous smooth flow may be interrupted.
- The concrete output is influenced and related to the quality and consistency of the concrete mix. Mix consistency is a decisive factor when it comes to the filling rate of the material cylinders.

With stiffer consistency and unfavorable grading curve of the aggregate, (smaller portion of sand, crushed materials) the rate of filling the material cylinders becomes less efficient resulting in a lesser concrete output. When you encounter this condition it is suggested that pumping at a slower speed can positively increase the output by allowing more time to fill the material cylinders.



REED MODEL: B20 TRAILER CONCRETE PUMP

OPER.

PAGE 23

- When it is necessary to pump unfavorable mixes such as extremely stiff, under sanded, lightweight concrete, the best procedure is to keep the remixer/agitator shaft visible all the time. In so doing, the hopper will only be filled to the lower edge of the remixer shaft making the concrete easier to pump.
- When it is necessary to pump concrete that is very liquid and has a high percentage of rough aggregate that tends to separate, keep the concrete level in the hopper as low as possible in case you encounter a work stoppage.
- Concrete that has separated or has begun to set and become lumpy should never be pumped.
- It is common that at sometime during the concrete placement you will be required to stop pumping for a period of time. This could be due to job site problems or possibly lack of concrete. Regardless of the reason, it is **IMPORTANT** to **MOVE** the concrete in the line during these periods. This can be accomplished by operating the pump in **REVERSE** for 2-3 strokes and then after another 10-15 minutes operate the pump **FORWARD** for 2-3 strokes.
- Downtime between forward and reverse movements will depend on the consistency and type of mix. Shutdown is for too long a period it may be necessary to clean out the delivery system and pump. Determine this from your experience in the material being pumped.
- Avoid having the material in the hopper separate during shut down.
- Air pockets in the delivery line can be dangerous as the air compresses within the delivery line and when it is released abruptly at the end of the line, the material being pumped is discharged in an explosive manner. Avoid air pockets. Keep sufficient material in hopper to prevent the induction of air into the material cylinders.
- Never bend or kink the flexible hose during the pumping operation. A kink is an obstruction that can stop the material flow, allowing pressure to build up in the system creating a dangerous condition.

When this occurs, the pumping direction must be **REVERSED** for 3-4 strokes to relieve the pressure in the line. Stop the pump and straighten out the kink, then resume pumping.

REVISION:

TROUBLESHOOTING TIPS - PUMPING & BLOCKAGE

- A drop in volume can occur when pumping long distances or with stiff mixes as compared with shorter lines and wetter mixes.
- Water leaking from a connection can cause separation of the mix in the delivery line and will eventually develop into a blockage at that point.
- Avoid using damaged hoses with internal restrictions. They can cause blockage.
- Don't be alarmed by a slight pulsation of the delivery hose near the outlet. This is a normal condition. However, excessive pulsation near the pump is normally due to higher than average line pressure that may be caused by pumping stiff harsh mixes or pumping extremely long distances. Using hose with a larger internal diameter will help in reducing the line pressure.
- Be alert to the fact that if the delivery system is blocked or the hose is kinked, the pump could suddenly force out the blockage or straighten out the kink. This rapid surge could cause the line to whip or move in such a manner that it may cause **INJURY**.
- When a blockage in the hose occurs, walk along the hose until you find the point of trouble. The hose will be soft immediately past the blockage point. Elevate the hose at that point with the blockage hanging down toward the free end. Shake the hose or pound with a hammer until the blockage loosens and the material flows freely again.
- **DOWNHILL** pumping involves some extra attention and can be difficult on some jobs. The reason for this is that when the pumping operation is stopped the material can flow slowly down the incline causing the hose to collapse. This can only result in a blockage when pumping is resumed. Kinking off the hose at the discharge while the pump is stopped can prevent this. Also the use of stiffer mixes when pumping downhill will lessen the gravity flow. Un-kink the hose before pumping is resumed.
- When pumping over 40 feet vertically up the side of a structure, steel pipe should be used and should be securely fastened as necessary to support the pipe column. Install long radius 90 degree pipe sweeps at the top and bottom of the steel pipe delivery line. Also use a short section 20-25 feet of hose off the pump discharge to take up the pulsation. Use steel pipe for the balance.



REED MODEL: B20 TRAILER CONCRETE PUMP

OPER.

PAGE 25

CLEARING A PACK OR BLOCKAGE

Blockage in the delivery line during pumping operation will no doubt happen at one time or another. An observant alert operator, who can recognize the symptoms is of great value. A blockage can create excessive pressure in the system which is a dangerous condition. When this occurs IMMEDIATELY STOP the pump.

- Place the pump direction switch to REVERSE. Then turn the pump switch to ON allowing the pump to stroke 2-3 times in reverse to assist in relieving the pressure from the delivery line blockage back to the pump outlet.
- Switch the pump OFF.

WARNING

NEVER ATTEMPT TO CLEAR A PACK OR BLOCKAGE IN THE DELIVERY SYSTEM USING THE PUMP PRESSURE.

- Warn all personnel in the immediate area of the imminent **DANGER** and to stay clear of the area.
- Make sure those assigned to clear the blockage are fitted with **EYE PROTECTION** before they open the clamping device.

WARNING

Extreme caution must be exercised when opening the clamping devices on any part of the delivery system. The possibility may still exist that there is still some pressure trapped in the line.

- Open the clamp in the area of the blockage and clear the pack.
- When blockage has been cleared **START** pump, placing **DIRECTION** switch to **FORWARD**. Pump the material at a **LOW VOLUME** until material flow steadily out the end hose.

REVISION:



REED MODEL: B20 TRAILER CONCRETE PUMP

CLEAN UP OF THE PUMP

This sometimes may seem tedious, tiresome and a distasteful task, however, the clean up is a VERY IMPORTANT operation. We pointed out previously the importance of the pre-operation inspection. The clean up is no different because it sets the stage as to how well the pump will perform the next time it is used. The clean up involves the removal of unpumped material remaining in the hopper, swing tube, material cylinders and delivery system piping.

NOTE

The flushing and cleaning operation should only be done at LOW VOLUME.

- At pump panel set VOLUME control to approximately 1/3 volume.
- With everything still intact, pump as much material out of the system as possible, making sure there is still sufficient material in the hopper for lubrication of the piston cups. Then turn PUMP switch to OFF position.
- Open the hopper clean out door and dispose of the remaining concrete
- Uncouple the delivery line at the pump outlet. If a reducer is used, disconnect the line right after the reducer.
- Using a water hose with spray nozzle attached to create some pressure, flush out the inside of the hopper, the inside of the S-tube and reducer if used.
- Place DIRECTION switch in REVERSE. Place the water hose through the pump discharge outlet. START the PUMP. Water will drain into the material cylinders and as pump cycles, any sand and rocks will be forced out through the open clean out door. This will take approximately 10-12 strokes.
- Remove the hose and continue to stroke the pump to make sure all the sand has been cleaned out. Turn the pump OFF.
- Close the hopper clean out door. Place the clean out sponge into the disconnected delivery line. Reconnect the line to the hopper outlet or reducer with the sponge inserted.

- Fill the hopper with water. Place the **DIRECTION** switch to the **FORWARD** position and check that **VOLUME** control is set at low speed. Turn **PUMP ON** and cycle the pump until the sponge passes through the entire delivery system.

⚠ CAUTION

*It is suggested that a **SPONGE CATCHER** be installed at the end of the delivery line to catch the sponge as it is discharged from the line.*

- Turn **OFF** pump and allow the water to drain from the system.
- Clean up the remaining areas of the machine hosing them down as appropriate.
PREPARE UNIT FOR TRAVEL.

After the **MODEL B20** has been thoroughly cleaned it can be now readied for travel.

- Return **THROTTLE** control to **IDLE** position, and shut-off engine.
- If remote control was used disconnect from control box and store in secure place.
- Pickup and store any wheel blocks, cones, delivery line and other equipment.
- Clean up area around pump.
- Connect unit to towing vehicle, raise outrigger legs and front jack.

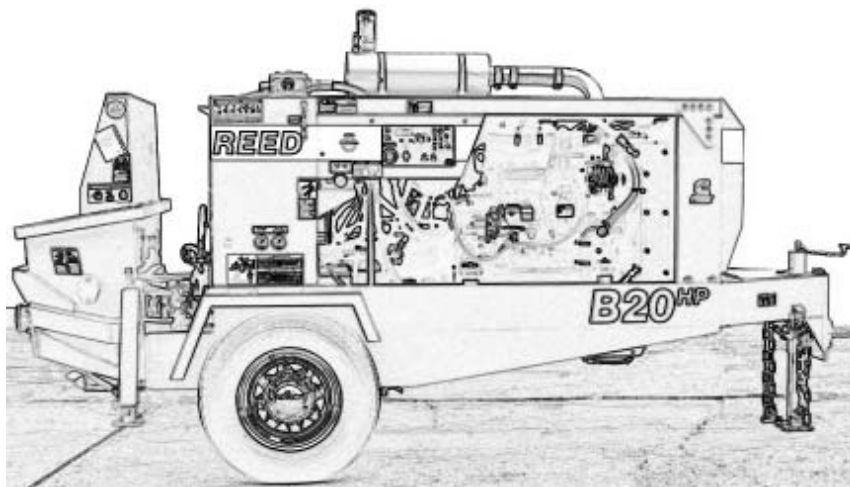



REED MODEL: B20 TRAILER CONCRETE PUMP

PREVENTATIVE MAINTENANCE

How good is any of the equipment you own? It is only as good as it is **MAINTAINED**. Even the finest equipment manufactured requires attention and care. The **REED MODEL B20** is no different. A good well planned and carried out preventative maintenance program will enhance a properly operating unit as well as the safety of those operating and using the equipment.

It is very important to establish a good maintenance program. Costly repairs and loss of revenue can often be avoided by planning ahead, setting up a regular schedule and exercising good preventative maintenance techniques.

The following section is offered as a guide and depicts a start for developing your own preventative maintenance program for the **MODEL B20** concrete pump. The program is depicted and broken into sections of **INSPECTION** and **LUBRICATION**.

NOTE

All points noted herein regarding the maintenance and checks are not intended to replace any local or regional regulations which may pertain to this type of equipment. It should also be noted that the list and schedule is not considered to be inclusive. Interval times may vary due to the climate and/or conditions associated with the location area in which the equipment will be used.

CAUTION

It is your responsibility to always insure that the applicable safety precautions are strictly observed when performing the inspections and maintenance checks. Make certain any components that are found to be defective are replaced or those in need of adjustments or repairs are corrected before operating the machine.



REED MODEL: B20 TRAILER CONCRETE PUMP

MAINT

PAGE 01

SCHEDULED INSPECTION

The main purpose of accomplishing scheduled inspections is to identify and detect any potential malfunction before it can expand into a major problem. The list presented herein should be inspected and checked on a regular basis. In so doing, it will help ensure a good, safe unit performance.

1. TRAILER

- Frame integrity, visually check welds for cracks
- Torsion axle secure
- Wheels and tires, lug nuts tight, tire inflation
- Electric brakes, break away switch connected
- Front jack stand handle turns easily, smoothly
- Manual jacks slide freely, lock pins in place
- Lighting good condition, operational

2. ENGINE

- Inspect mountings, bolts, brackets
- Oil level proper, free of leaks
- Fuel system, tank mounting, filter condition, no leaks, or damaged lines
- Battery hold down, condition, tightness of cables
- Key switch, indicator lights operable
- Throttle control functional
- Air cleaner and muffler securely mounted

REVISION:

3. PUMP CELL

- Visually check for structural damage, cracked welds
- Hydraulic drive cylinders in good condition, secure, no leakage
- Material cylinders secure, tie rods tight
- Water box/flushbox structurally sound, clean, cover in place
- S-tube shift mechanism structurally sound, all pins and retainers in place
- Hydraulic shift cylinders in good condition
- Bearing housing, seals etc. in good condition
- Hydraulic hoses secure, no leaks

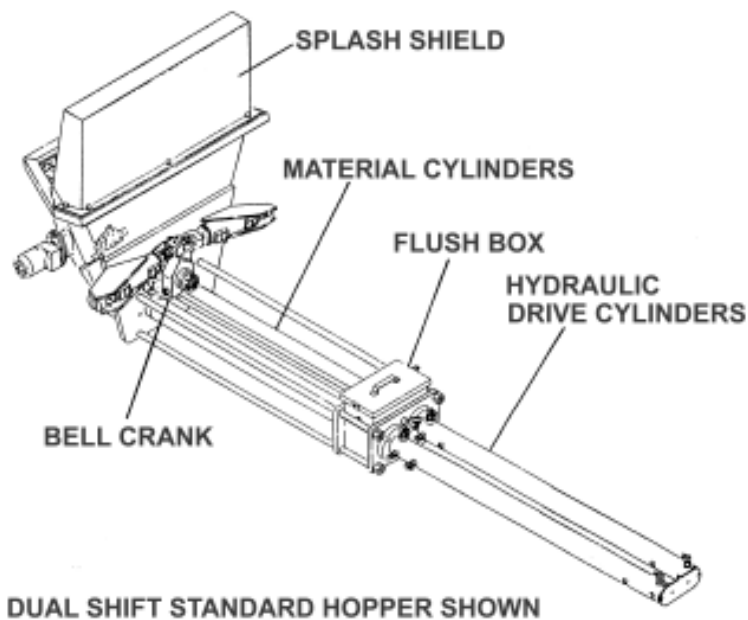

4. HOPPER ASSEMBLY

- Visually check for structural damage, cracked welds
- S-tube secure, in good condition
- Check condition of wear plate, wear ring, seals

- Check connection of S-tube to outlet, seals, bearing
- Hopper drain is functional
- Remixer / Agitator in good condition, motor secure

5. MAIN CONTROL

- Control box in good condition, not damaged
- All toggles in good condition, stay in position or momentarily return to center
- Control identification in good condition, legible
- Gauges in good condition

6. REMOTE CONTROL

- Control console in good condition, not damaged
- Switch in good condition
- Umbilical cord in good condition, no cuts, securely mounted to box

7. HYDRAULIC SYSTEM

- Hydraulic tank securely mounted, covers tight
- Filler cap and strainer in place, level sight gauge in proper condition
- Check filter condition indicators
- Hydraulic oil cooler securely mounted, fan motor secure, connections tight
- Check accumulator condition, mounting brackets & clamps
- Hydraulic fluid to proper level and clean
- All hoses and tubing secure, no leaks

LUBRICATION

The **MODEL B20** concrete pump is equipped with several components that because of the application require frequent lubrication. These areas involve the S-tube shifting mechanism, swing components, the shift and outlet bearings and agitator. To insure the economical service and long life of these components, grease fittings are installed at each point.

WARNING

Rapid wear and probable component breakdown will result if the unit is operated with inadequate lubrication. Follow the recommended interval and if need be increase the interval when above normal usage takes place.

LUBE POINT LOCATION

- **Swing Tube Shift**
 - Quantity 1 at cylinder barrel pivot
 - Quantity 1 at bell crank
 - Quantity 2 at swing tube shaft bearing housing
 - Swing tube shift cylinders accept grease best when s-tube gauge reads zero

- **Swing Tube Outlet**
 - Quantity 2 on outlet bearing housing

- **Agitator/Remixer**
 - Quantity 2 - On non motor end
 - Quantity 1 - One on motor end

Recommended Lubricant: **GENERAL PURPOSE GREASE, SHELL ALVANIA EPLFH2 or EQUIVALENT**

Recommended Interval: **DAILY, BEFORE START-UP, AS REQUIRED DURING OPERATION, AND AFTER THE DAYS PUMPING AND CLEANING ARE FINISHED**

LUBRICANT AND INTERVAL

The lubricant that is recommended is generally the best choice, however, should this lubricant be unavailable in your area, consult your local supplier for an equivalent.

On the same basis, recommended lubrication intervals are based on normal use, in normal environmental conditions. User is **CAUTIONED** to adjust the lubrication interval accordingly to meet each individual condition and usage. If the swing tube bearing housings become extremely hot or lubricant becomes a liquid and oozes out around the bearing or seal, the area should be relubricated.

If the **MODEL B20** has been stored or exposed to environmental conditions of extreme low humidity, high dust level, elevated temperatures or heavy rainfall, lubrication of components may be required more frequently than under normal conditions.

NOTE

External non-bearing surfaces should be wiped clean of extruded or spilled surplus grease and oil with a clean, but lint free cloth to prevent damaging dust and abrasive accumulation on lubricant wet surfaces.

GENERAL PURPOSE GREASE GUNS

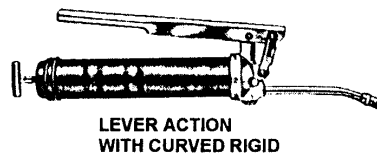
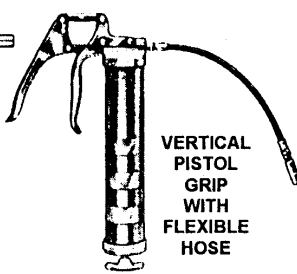
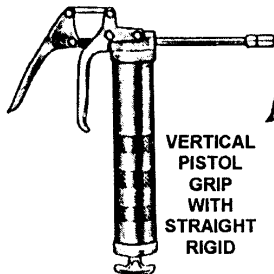

HAND HELD ELECTRIC GREASE GUN

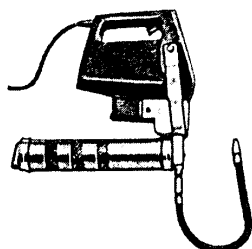

EXTREME PRESSURE GREASE GUN

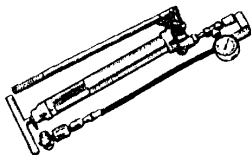

AIR POWERED GREASE GUN

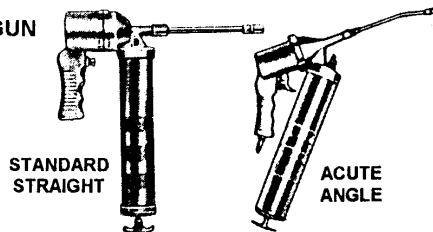



REED MODEL: B20 TRAILER CONCRETE PUMP

MAINT.

PAGE 06

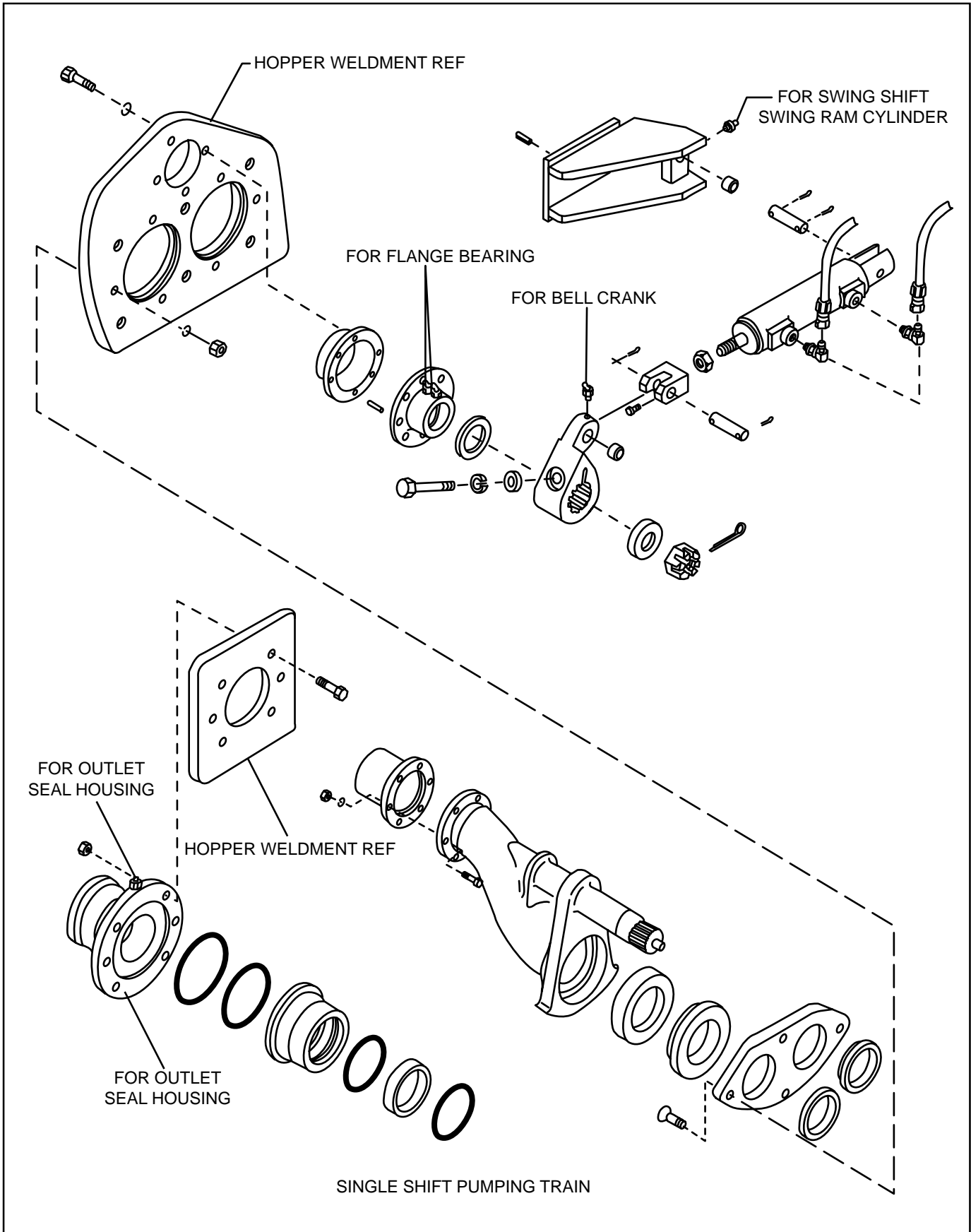

REVISION:



REED MODEL: B20 TRAILER CONCRETE PUMP

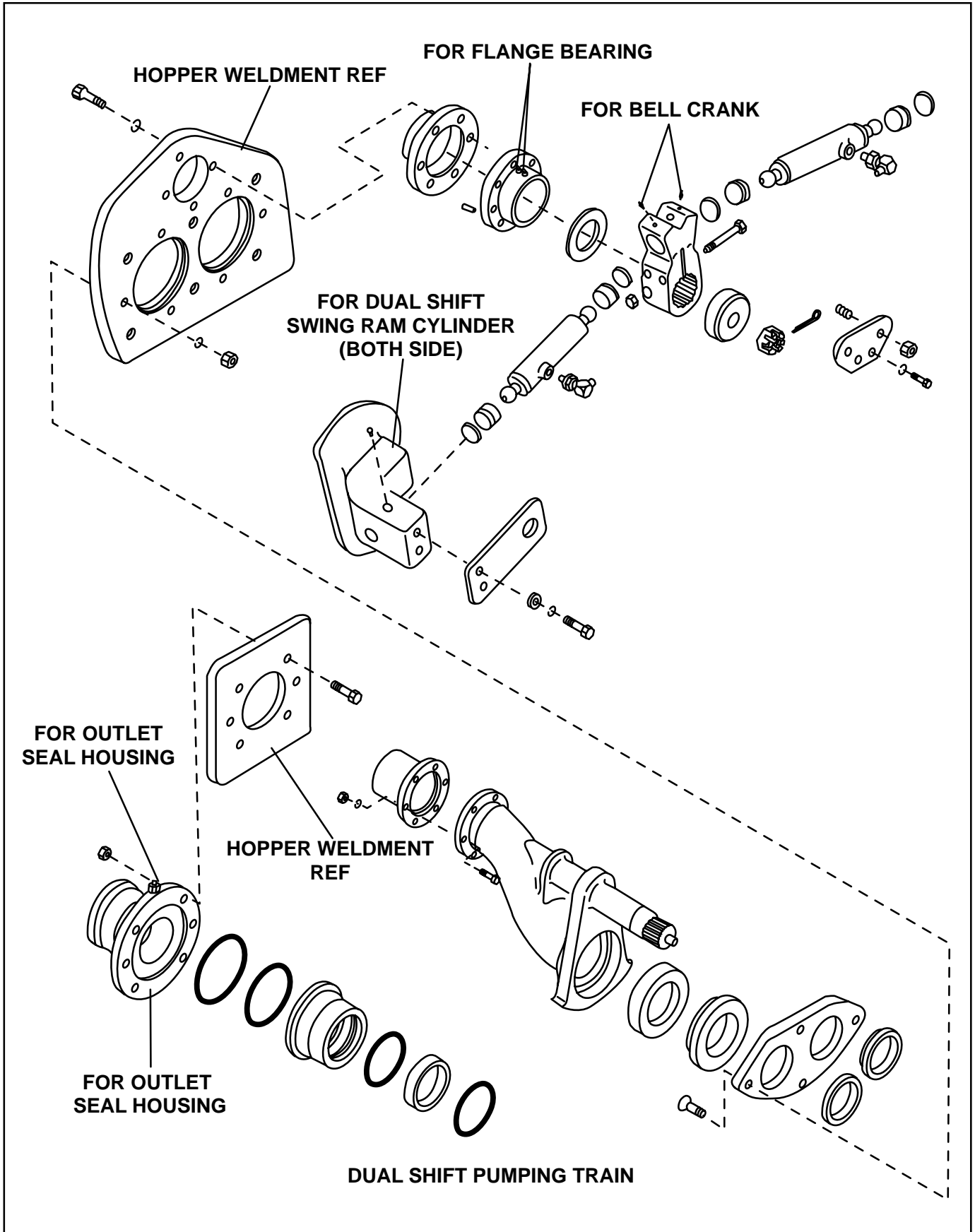

REVISION:



REED MODEL: B20 TRAILER CONCRETE PUMP

HYDRAULIC SYSTEM MAINTENANCE

The **REED MODEL B20** utilizes a diesel engine as the main source of power, which drives the main hydraulic pump. The hydraulic pump is used to supply the flow and develop the necessary pressure to operate the concrete pump. As with any operational system, it is only as good as it is maintained. The hydraulic system is a critical system and it is for this reason that it is **IMPORTANT** that it receive extra care and good maintenance. This section is offered to alert you and guide you in maintaining the hydraulic system.

CAUTION

CONTAMINATION is the downfall of most hydraulic systems and a major contributor leading to system malfunctions. Extreme care must be exercised to prevent dirt from entering the system. Make it a habit to ALWAYS cap or plug open ports and hydraulic lines.

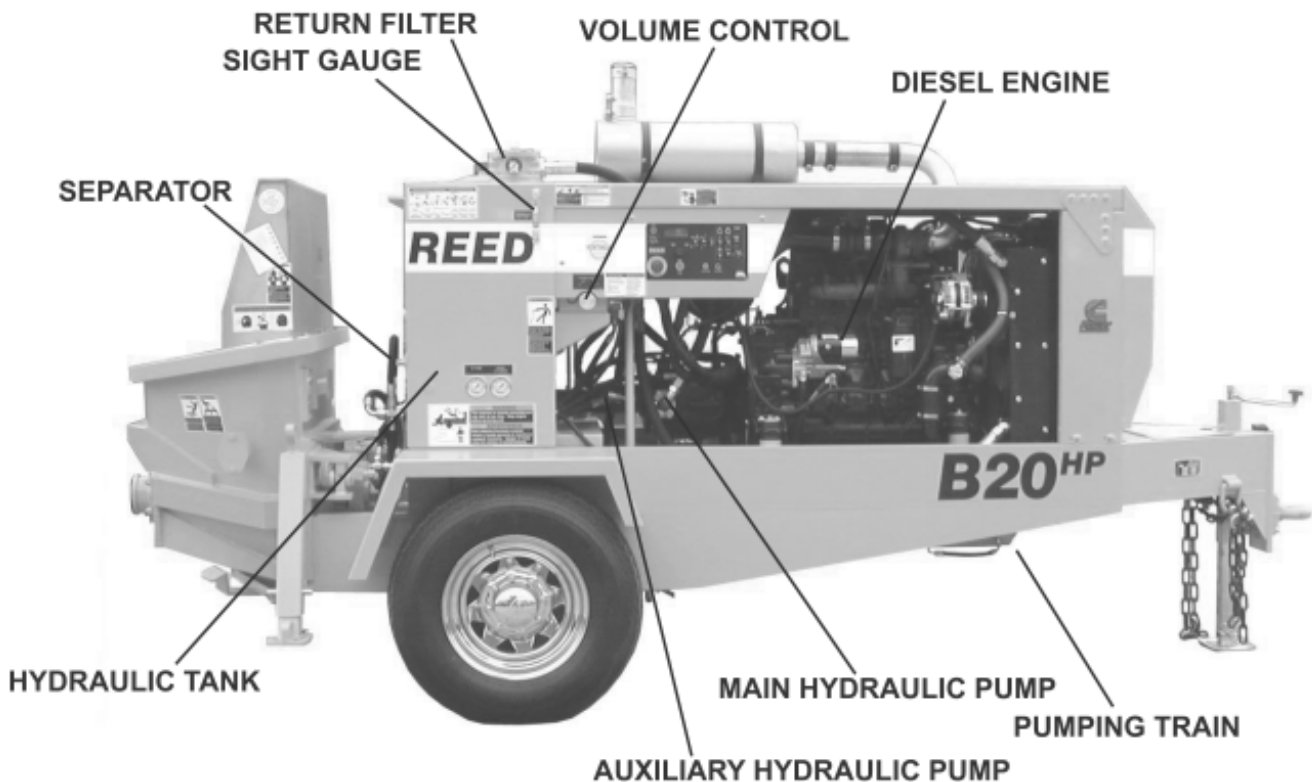

HYDRAULIC TANK

The hydraulic tank has a capacity of 55 GALS (208L) and is located just forward of the hopper. It is equipped with a filler breather unit, access cover and two (2) magnetic suction strainers inside the tank. A sight gauge is installed on the left side of the tank and is used to determine the fluid level inside the tank. The tank is also equipped with a drain valve.

Filtration is provided by return line filter located on top of the tank. An oil cooler is adjacent to the engine cooling unit. This cooler is used to cool the oil prior to entering the tank.

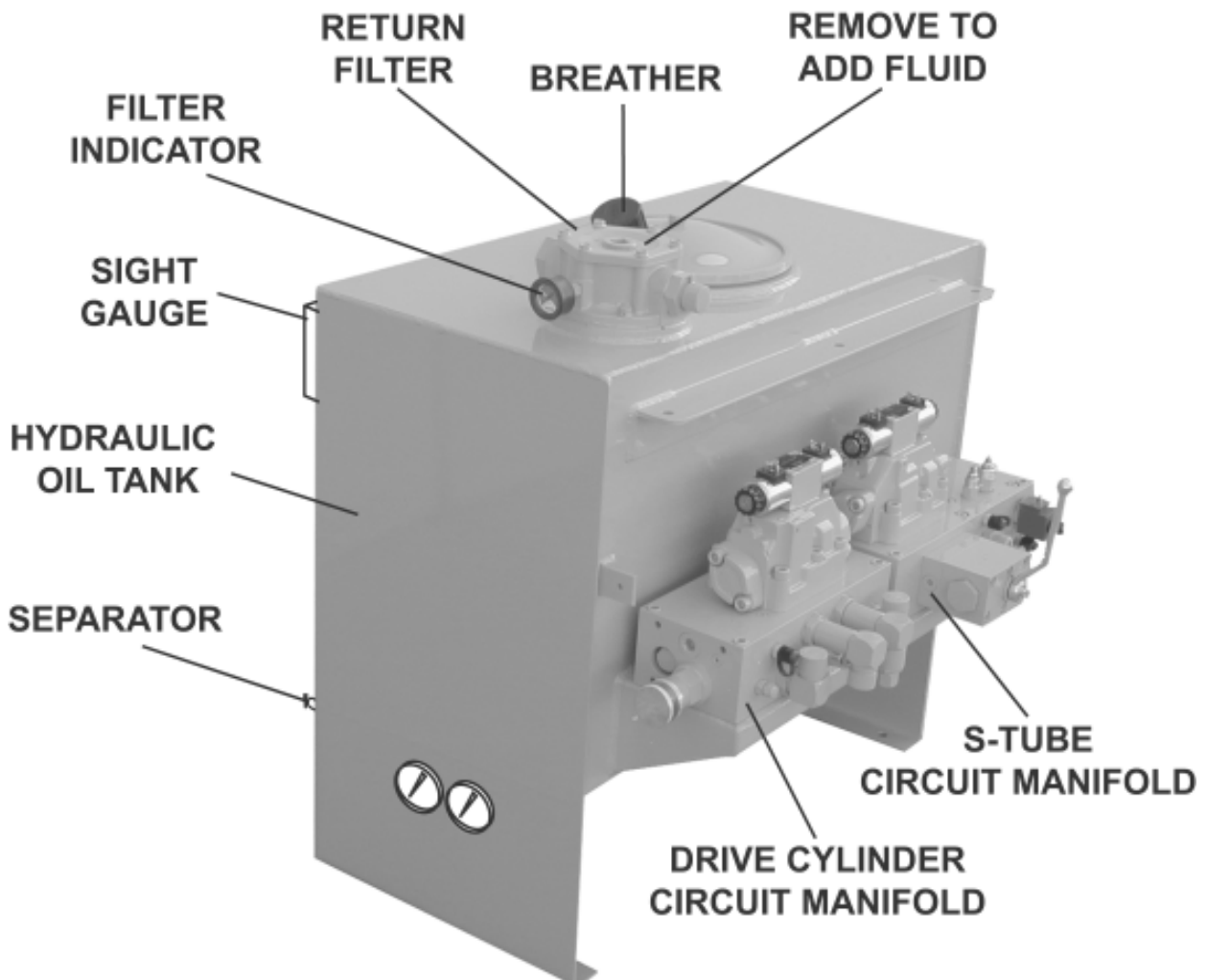



REED MODEL: B20 TRAILER CONCRETE PUMP

MAINT

PAGE 10

SYSTEM MAINTENANCE ITEMS

The following are specific items for care and maintenance of the hydraulic system.

- **FLUID LEVEL** Check level daily with sight gauge provided. Maintain level at full mark. Add through filter.
- **TANK BREATHER** Clean every 50 hours of operation. Remove from tank, clean with solvent and air blow dry.
- **RETURN LINE FILTER** One (1) 10-micron filter; change after first 50 hours of operation. Thereafter change every 150 hours of operation or when condition gauge indicates to do so.
- **HYDRAULIC TANK** Change oil in tank every 1000 hours of operation or yearly whichever comes first.

NOTE

After fluid loss fro any reason, filter replacement, component removal etc., sufficient fluid must be added to properly maintain required level in tank.

HYDRAULIC FLUID

The **MODEL B20** utilizes in its hydraulic system a fluid manufactured by the SHELL OIL CO. and is designated as TELLUS #46. It is to be used in ambient temperatures of 39-90° F (4-32° C). The normal fluid temperature will range from 100-167° F (38-75° C).

For ambient temperatures of 90° (32 °C) and above use fluid designated as a ISO rating of 68. Use ISO 32 for ambient temperatures of 32° F (4° C) and below.

WARNING

USE ONLY SHELL TELLUS 46 or equal hydraulic fluid and NEVER MIX with other type fluids. Always use a CLEAN fluid. Using impure or other type of fluids not specified will contaminate the hydraulic system and can lead to eventual system malfunction or damage and possibly deteriorate the hydraulic seals.

REVISION:

ADDING HYDRAULIC FLUID

As previously indicated, a hydraulic systems worst enemy is **CONTAMINATION**. Exercise extreme care when adding fluid to the hydraulic tank.

- To prevent any dirt or water from entering the hydraulic tank, thoroughly clean area around top of filter. Remove plug on top of filter.
- Use fresh clean hydraulic fluid. If a hand pump is used to transfer the fluid, check that pump filter is clean. If pouring of fluid from a container, pour it through a fine wire mesh screen, 200 mesh or finer.
- Replace plug immediately after filling tank to proper level.

⚠ WARNING

Do not use a cloth for straining fluid as lint is harmful to the hydraulic system.

FILTER SERVICING

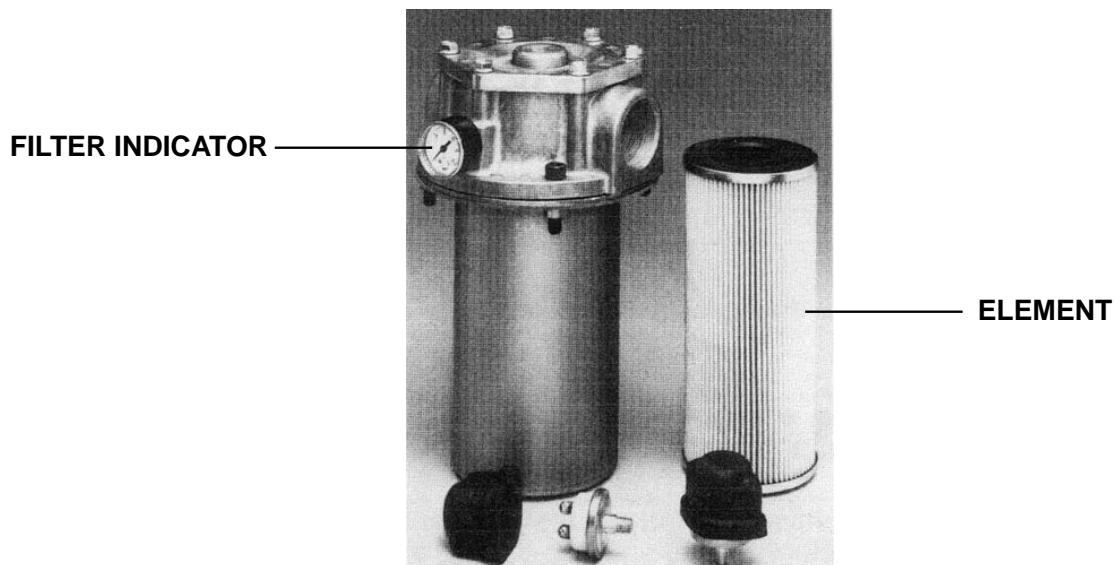

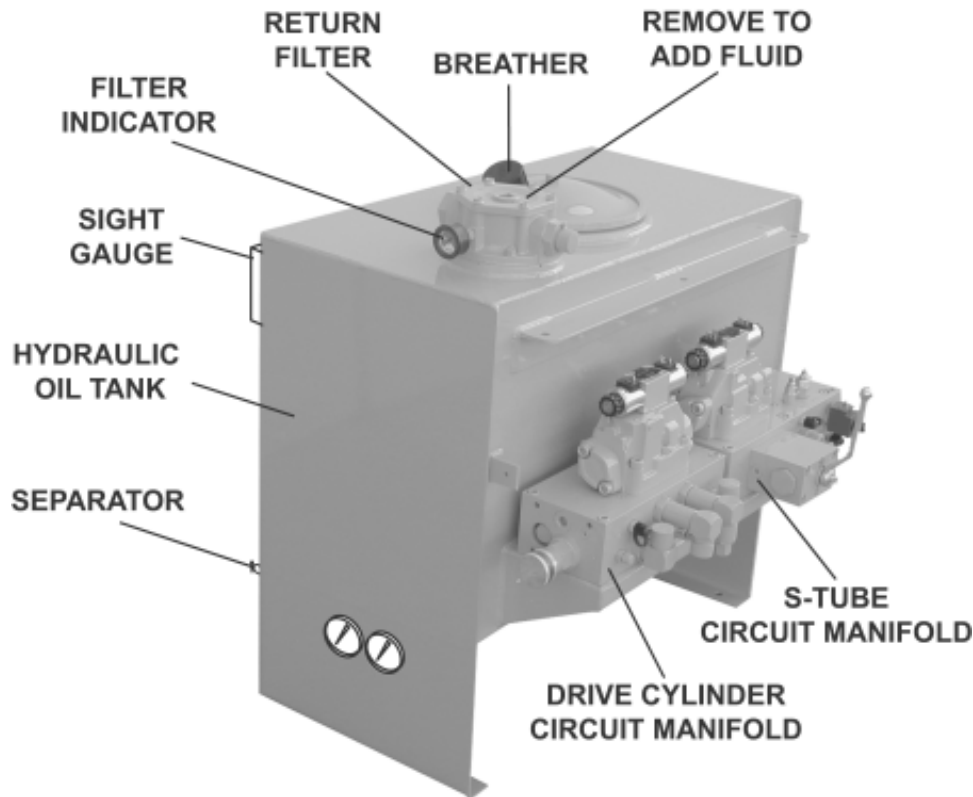

The purpose of installing hydraulic filters in the system is to provide a means of continuous hydraulic fluid filtration in an effort to prevent recirculation of abrasive solids which will cause rapid wear of component breakdown.

The **B20** filter system consists of a return filter located on top of the tank. The filter is equipped with a condition indicator gauge which should be checked periodically and the element changed when gauge reads 25 psi or higher.

To service/change the filter elements, the following is offered:

- Shut off machine. On pump circuit allow accumulator system to depressurize.
- Wipe clean any dirt and grime from around filter housing on top of tank.
- Remove the six (6) bolts holding on top plate of filter.
- Carefully remove cover so as not to damage the gasket.
- Remove element, remove bypass valve from element, discard element.
- Install bypass valve into new element, install element and replace cover.

REED**REED MODEL: B20
TRAILER CONCRETE PUMP**

- Start up machine and observe for leakage.

⚠ CAUTION

DO NOT ATTEMPT TO WASH OUT FILTER ELEMENT. These are disposable types and more harm can be done than it is worth.

CLEANING THE HYDRAULIC TANK

The hydraulic tank should be drained and cleaned after 1000 hours of operation or yearly whichever comes first. This will assist in keeping the systems clean and in proper condition. To accomplish this the following is offered.

- Shut off machine. On pump circuit allow accumulator system to depressurize.
Place a suitable size container under the hydraulic tank drain fitting located at back of tank facing the hopper. **NOTE:** The tank has a capacity of 55 gallons (208 L). Make sure your drain container is large enough. Remove drain plug.
- Remove the access cover on the hydraulic tank being careful not to damage the gasket.
- Remove the two (2) suction strainers.
- After tank has drained, flush the inside of the hydraulic tank with clean solvent and wipe clean with lint free cloths. **DO NOT USE PAPER TOWELS.** Remove any particles from tank bottom and sump.
- Clean the suction strainers by, disassembling, soaking them in fresh solvent and then air blow dry. Re-assemble suction strainers.
- Install the tank drain plug. Reinstall the suction strainers and access cover with gasket.
- Clean the filter breather with solvent and air blow dry.
- Change the hydraulic system filter element.
- Refill the hydraulic tank with new **CLEAN** hydraulic fluid, **SHELL TELLUS 46.**
- Start machine and check for leaks.



REED MODEL: B20 TRAILER CONCRETE PUMP

MAINT

PAGE 14

DESCRIPTION OF HYDRAULIC SYSTEM

The hydraulic system of the **MODEL B20** consists of three separate circuits and although integrated, each is designed to perform a particular function within the operation of the concrete pump. The three circuits utilized are:

- **Main Pump Circuit** - it controls the function for operation of the hydraulic drive cylinder and material cylinders.
- **S-tube Shift Circuit** - it controls the function for operating of shifting the S-tube from one material cylinder to the other during concrete pumping.
- **Auxiliary Circuit** - This controls the operational function for the agitator.

For the purpose of making the operation of each circuit easier to understand, they are being described separately.

SPECIFICS - PRESSURES

- Main Pump Standby Pressure = 230 PSI (16 Bar)
- Main System Max. Pressure = 4000 PSI (276 Bar)
- Main System Relief Pressure = 4400 PSI (303 Bar)
- S-tube Shift System Relief Pressure = 2000 PSI (138 Bar)
- Accumulator Pre-Charge Pressure = 1000 PSI (69 Bar)
- Auxiliary System Relief Pressure = 1500 PSI (103 Bar)
- Main System Pressure indicated on drive cylinder 6000 PSI(414 Bar) gauge
- Swing Tube Pressure indicated on s-tube 3000 PSI(207 Bar) gauge

SYSTEM FILTRATION

The hydraulic tank has a capacity of 55 gallons (208 L) of **SHELL TELLUS #46** hydraulic fluid. The start of system filtration begins inside the tank where two (2) magnetic type suction strainers are installed. The system return fluid must pass through a 10-micron filter element before returning to the tank and after passing through the oil cooler.

REVISION:

MAIN PUMP CIRCUIT (Refer to Hydraulic Schematic)

The **MODEL B20** is designed to pump concrete like material from the hopper to the placement site. To accomplish this requires the use of two (2) material cylinders that are driven by two (2) hydraulic cylinders and the material pumping action is the result of the two cylinders operating or stroking on an alternate basis. In other words, when one cylinder is retracting it is drawing into the material cylinder tube the material from the hopper. The other cylinder, which has its material cylinder already full, is extending. This causes the material to be pushed through the swing tube and out into the delivery line. This action continually takes place. This is the purpose of the **MAIN PUMP** circuit, to provide the hydraulic power for this operation.

The **MAIN PUMP CIRCUIT** is of the **OPEN LOOP** type. Meaning, that the hydraulic pump directs the fluid to one hydraulic cylinder to extend and the oil from the retracting cylinder is directed back to the tank.

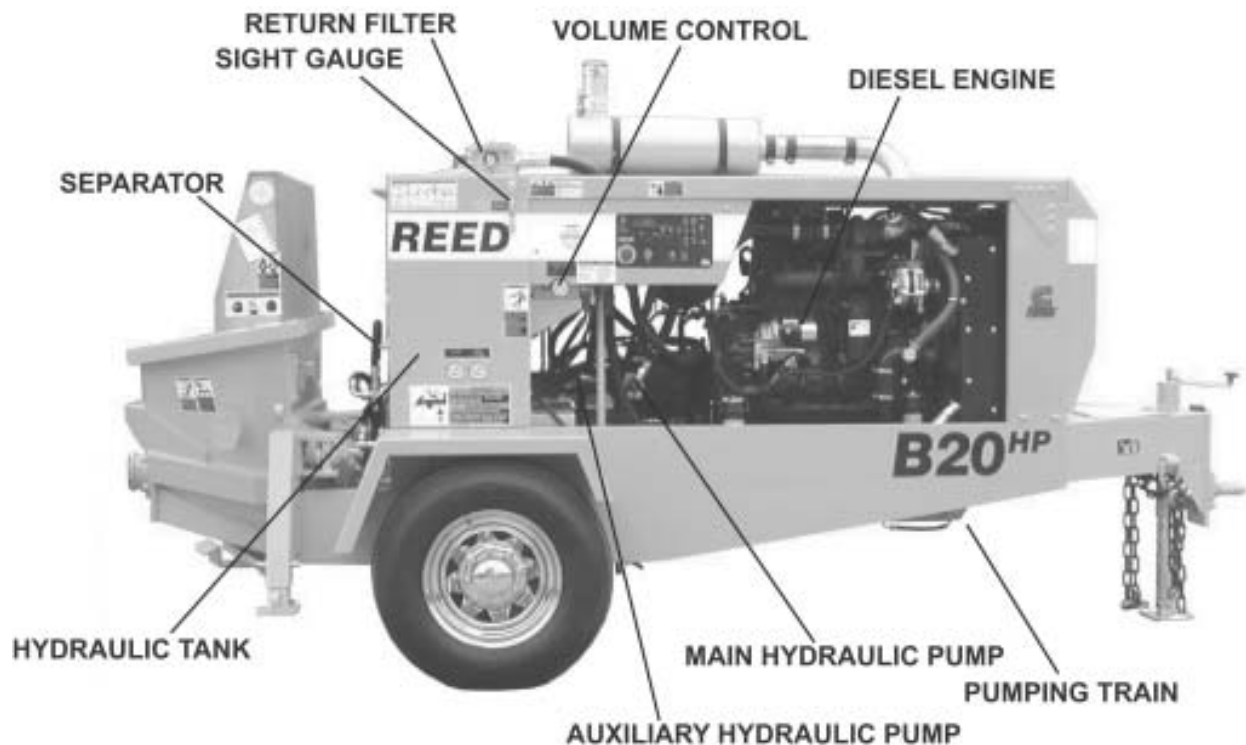

To meet the volume and pressure requirements of the main pump circuit a Rexroth hydraulic pump is used. This pump is a variable displacement axial piston pump of a swashplate design. The pistons run against the swashplate, which is capable of being tilted.

This tilting or angle varies the stroke length of the pistons which in turn varies the displacement of the fluid. The larger the angle, the greater the flow. In the case of the **MODEL B20**, the angle of the swashplate is varied by use of the **VOLUME** control that works in conjunction with the load sense feature of the pump.

The main hydraulic pump is driven directly by the Deutz diesel engine. When the engine is started and running and the **PUMP** switch is in the **OFF** position, and the **VOLUME** control turned **IN** there is no demand placed on the pump. This is referred to as the pump being de-stroked, meaning, it is only producing a minimal amount of flow to enable the lubrication of the pump. This condition exists regardless of whether the engine is at idle or maximum **RPM**.

The main pump circuit is equipped with a manifold block installed at the rear of the hydraulic tank. This manifold is drilled and ported to accommodate the relief valve, check valve, flow control and the pilot operated cycle valve. The cycle valve is a directional spool valve with electro hydraulic solenoid operation. Its purpose is to direct the flow of oil to one or the other hydraulic drive cylinders.

To energize the pump circuit, set the engine speed at maximum **RPM**, adjusted by use of the throttle control. Open the **VOLUME** control to any range of 0 to full. In so doing, the load sense is alerted to the demand and places the pump on stroke. The pump will now produce the flow in proportion to the amount by which the volume control has been opened. Since the **PUMP** switch is **OFF**, the flow from the hydraulic pump is directed to the cycling valve, thru the valve, then returns to the hydraulic tank.

To energize the cycling circuit, the **PUMP** switch must be **ON**. When this is done, an electrical signal is generated which in turn energizes the coils of the main cycling pilot valve and also activates the swing tube shift circuit. (Described later)

Where, how and why is this electrical signal generated?

It was previously noted that the material pumping action is the result of the two material cylinders cycling on an alternate basis. This alternating cycling is controlled by an electrical signal that is generated at the end of each material cylinder's suction, retraction stroke.

A proximity sensor, one for each material cylinder, is installed in the flush box. As the piston coupler passes under the proximity sensor, it generates an electrical signal that is sent to the logic controller or which is better know as the black box. The black box is a **REED** proprietary solid state device, designed to control the alternating action of the material cylinders and to synchronize the movement of the swing tube. The signal from the black box is used to energize the coils of the main cycling pilot valve as well as that of the swing tube shift valve.

CIRCUIT OPERATIONAL SEQUENCE

In the operational sequence of the **MAIN PUMP CIRCUIT** and with the engine started and throttle adjusted to maximum, the main pump is idling. When the **PUMP** switch is placed **ON** and volume control open, the hydraulic drive cylinders begin to cycle. The cylinder to receive the flow from the hydraulic pump via the cycling valve, is the cylinder whose coupler has triggered the proximity sensor while in the retracted position and is ready to extend. At full extension the other cylinder is totally retracted and the coupler activates the proximity sensor which via the black box, shifts the main cycling valve spool, allowing the oil to flow to the now retracted cylinder. This altering cycling takes place continuously until the **PUMP** switch is turned **OFF**.

It can be noted in the schematic and the diagram below that the main pressure and flow is only directed to one side of the hydraulic drive cylinder. In this instance, it is directed to the barrel or piston side of the cylinder.

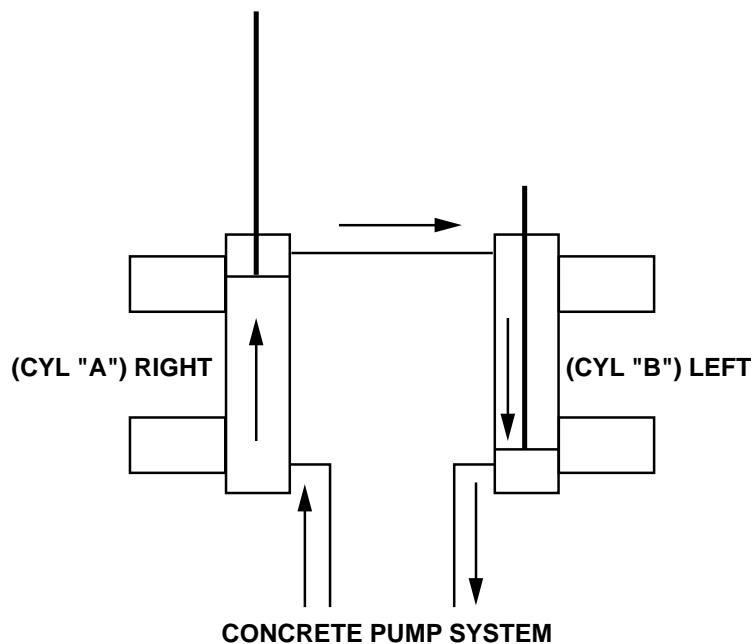

The hydraulic drive cylinders are identical and because only one cylinder is pressurized at a time, a means is required to assist in the retraction of the opposite cylinder. This is accomplished by connecting the rod sides of the cylinders together. In so doing, the hydraulic fluid that exists in the rod side of the extending cylinder (**CYL A**) is transferred and directed to the rod side of the other cylinder (**CYL B**) causing it to retract. The oil in the barrel of **CYL B** is then forced out and has a free flow through the cycling valve back to the hydraulic tank or return system.

With this arrangement of connecting the two cylinders together, it is possible for various reasons, such as leakage around the piston seals that more oil exists on the rod side of the cylinder than is required. When this condition exists, some hydraulic oil remains at the rod end of the cylinder being extended while the other cylinder is fully retracted. As a result the cylinder cannot be totally extended and thus is **SHORT STROKES** which will also happen eventually to the other cylinder.

This condition can be corrected by actuating the switch on the electrical control box to position "A" or "B" whichever cylinder is extending, and to **HOLD** switch until extended cylinder is fully bottomed out. Hydraulically, this is accomplished by use of the check valves installed on both cylinders. By holding the **CYL A-B** switch, you have interrupted the cycle and are forcing more oil into the barrel of the extending cylinder "A", putting more oil on the rod side which is then transferred to the rod side of **CYL "B"**. Since that cavity is full, pressure is built up in the rod side of **CYL "B"**, which unseats the barrel side check valve forcing the excess oil back to the tank. Once the extending cylinder is at full stroke, regular operation can continue.

NOTE

*In addition to piston leakage, a **SHORT STROKE** condition may result from incorrect proximity sensor location or leaking check valves.*

As protection to the **MAIN PUMP CIRCUIT** against excessive pressure, a relief valve has been installed and is set to open at 4400 PSI which is 400 PSI over the main system pressure. Thus when the system pressure reaches 4400 PSI, the relief valve opens directing the oil back to the tank.

S-TUBE SHIFT CIRCUIT (Refer to Hydraulic Schematic)

In the foregoing description of the Main Pump Circuit, we learned that the hydraulic drive cylinders operate on an alternating basis causing the material cylinders to do the same. Since there is only one outlet for the pumping material, a means is required to transfer the material from the material cylinder to the outlet and into the delivery line. To accomplish this a component referred to as the swing tube or S-tube is installed in the hopper. Since there are two material cylinders and one S-tube, the S-tube must be shifted from one material cylinder to the other, whichever one is loaded with the pumping material. Thus the incorporation of a **S-TUBE SHIFT CIRCUIT**.



REED MODEL: B20 TRAILER CONCRETE PUMP

The S-tube shift hydraulic circuit is of the open center type, meaning that when the control valves are in the **NEUTRAL** position hydraulic non operational (unactuated), the internal passages of the valves are open, free flow, allowing the hydraulic fluid to return to the tank. With the engine running the hydraulic pump is operating, producing a flow of oil which, with no control energized, will pass through the shift circuit on its way back to the tank.

To meet the flow and pressure requirements of the shift circuit, one section of a tandem pump is used. Note: a single pump is used if unit is not equipped with an agitator. The **TANDEM HYDRAULIC PUMP** is of the gear pump design, having a fixed displacement meaning it is designed to constantly produce the same displacement at preset maximum engine RPM. The tandem gear pump is directly connected and driven through the Rexroth pump. In addition to the hydraulic pump, the swing tube shift circuit consists of an unloader manifold, an accumulator, a solenoid directional valve and two (2) hydraulic cylinders. The following is offered to describe the function of each in the system.

SHIFT CIRCUIT MANIFOLD

Like the main hydraulic circuit, the shift circuit is also equipped with a manifold block. This block is located adjacent to the main circuit block. It contains a relief cartridge, solenoid valve cartridge, check valve and a differential pressure sensor. A solenoid operated directional valve is mounted on top of the block and a S-tube selector control valve is located on front of the block. Each of these components is designed to perform a particular function in the swing circuit as explained in the following descriptions.

- **RELIEF CARTRIDGE** - This cartridge is located on the top side of the manifold block and is used to protect the system from excessive pressure and to limit the amount of pressure being applied to the accumulator and is set at 2400 PSI (165 Bar). It also acts as a dump valve.
- **UNLOADER VALVE** - This cartridge is used to divert the pump flow from going to the accumulator once its capacity has been reached, directing it back to tank. It becomes operational when the relief cartridge setting has been reached.
- **SOLENOID VALVE CARTRIDGE** – There are two (2) of these cartridges used in the circuit. Both, which may be referred to as a dump valve, are designed into the circuit as **SAFETY VALVES**. Their purpose is to automatically relieve pressure from the shift circuit as commanded by the emergency stop circuit. At start up, the normally open cartridges are open to tank so the shift circuit can not build any pressure. When the emergency stop circuit is reset, an electrical signal is generated which energizes the solenoids, closing the cartridges and allowing the shift circuit to pressurize.

When the emergency stop function is activated or the key switch turned off, the power is taken away from solenoids, causing the cartridges to open and dump shift circuit pressure back to tank.

The second valve is also used as a dump valve and is used to direct the flow of oil back to the tank when the accumulator pressure has been reached, thereby eliminating the surging of the relief valve.

- **SOLENOID DIRECTIONAL VALVE** - This valve is a directional control valve that is shifted electronically via a 12 volt solenoid. Its purpose is to direct the flow of oil from the accumulator to one or the other end of the shift cylinder based on the signal received from the black box that was generated by the proximity sensor.
- **SHIFT BALL VALVE** - This is a manual ball valve and is used to control the S-tube shift. With valve fully opened, the flow is unrestricted, causing a fast hard shift of the S-tube. When the valve is closed, the shift is slower as it must now pass through an orifice.

ACCUMULATOR

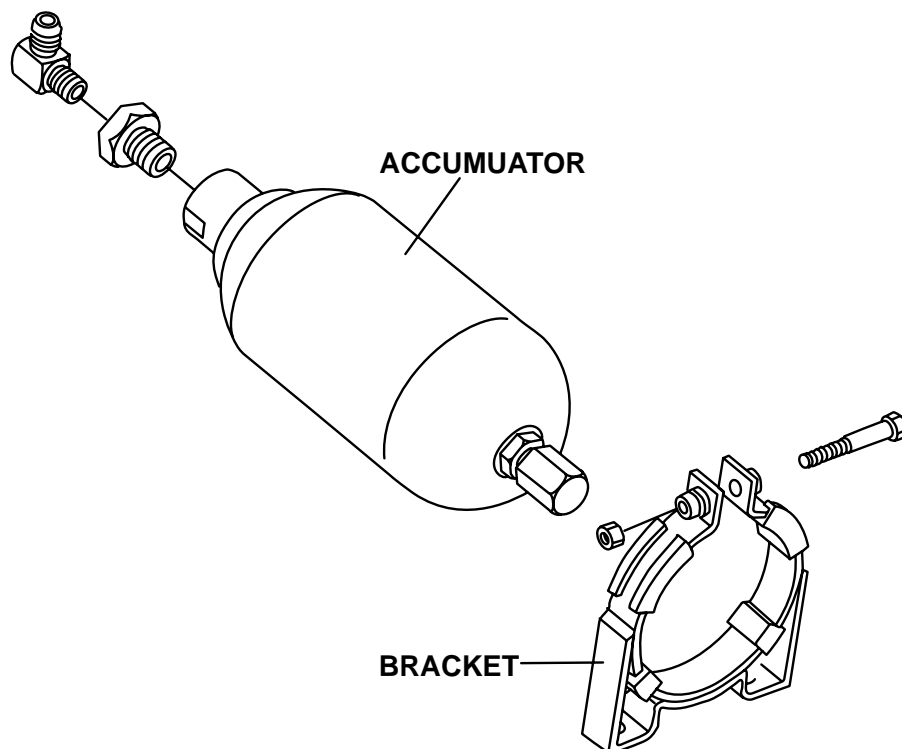

REED**REED MODEL: B20
TRAILER CONCRETE PUMP**

The accumulator is incorporated into the shift circuit to provide instant pressure and volume for the shifting of the swing tube, which cannot be obtained under normal circumstances. An accumulator is a hydraulic reservoir that retains the hydraulic fluid under high pressure.

To accomplish this, the accumulator contains a rubber bladder on the inside of the reservoir. This bladder prior to the installation of the accumulator on the machine must be pre-charged to a certain pressure using a dry nitrogen gas. In this pre-charge operation, the bladder is expanded much like a balloon and is retained in that state. In the application of the shift circuit, the hydraulic fluid is pumped into the accumulator at a higher pressure than that of inside the bladder. This compresses the bladder building up high pressure within the accumulator that is retained until released.

CIRCUIT OPERATIONAL SEQUENCE

In the operational sequence of the shift circuit with the engine at full **RPM**, the tandem pump is operating, producing its rated displacement. The flow is going through the system and is being dumped or directed back to the tank by the solenoid cartridge of the unloader manifold.

When the **HORN/RESET** switch is placed to **RESET**, an electrical signal closes the solenoid cartridges. When this occurs the hydraulic fluid is now directed to the accumulator where it starts compressing the bladder building up pressure. When the pressure in the shift circuit reaches the setting of an unloader valve, 2000 PSI (138 Bar) in this application, the unloader valve activates causing the relief cartridges to open. The open valve now directs the oil flow from the pump back to the tank in lieu of continuing to pressurize the accumulator. A check valve then holds pressure in the swing circuit and prevents the fluid from going back into the pump line.

In the Main Pump Circuit description it was described how an electrical signal was generated by the proximity sensor which was sent to the black box and used to control the alternating action of the hydraulic drive cylinders. This same signal is also used to shift the swing tube so that its movement is synchronized with that of the hydraulic drive cylinder, shifting the swing tube to the material cylinder, which is ready to extend (normal forward operation).

The electrical signal activates the solenoid coil of the directional valve, shifting the spool to the appropriate side. The accumulator then releases, exhausting the fluid which is then directed to the appropriate side of the shift cylinder. As soon as the shift is made the accumulator is refilled immediately and the sequence starts all over again.

AUXILIARY CIRCUIT

The **AUXILIARY CIRCUIT** used on the *Model B20* has been designed and installed for the purpose of operating the hydraulic function of the agitator. This function is that of the agitator rotation for mixing the material in the hopper.

The flow and pressure requirements for the auxiliary circuit is met by employing the second stage or section of the same tandem pump used on the swing tube shift circuit. With the engine running and throttle set to maximum **RPM**, the flow from the tandem pump is directed to a single spool directional control valve. As well as a **SAFETY VALVE**, also referred to as a dump valve. Its purpose is to prevent flow to the auxiliary circuit as commanded by the emergency stop circuit. At start up, the normally open cartridge directs the oil flow from the tandem pump to tank, ceasing function for the auxiliary circuit. When the emergency stop circuit is reset, an electrical signal is generated which energizes the solenoid, closing the cartridge, blocking flow directly back to tank, instead allowing the flow to the single spool directional control valve for operation.

When the valve lever is moved away from the hopper the agitator will rotate in a forward direction as hydraulic fluid is directed to that side of the motor. The rotation can be reversed by moving lever in other direction.

A flow control valve is installed in the hydraulic line for forward rotation. The purpose of this valve is to adjust flow to that particular side of the motor which in turn regulates the rotation speed. Turn flow control knob clockwise to decrease speed.

A relief valve is installed in the directional control valve and is set at 1200 PSI. This is used to protect the system against excessive pressure.

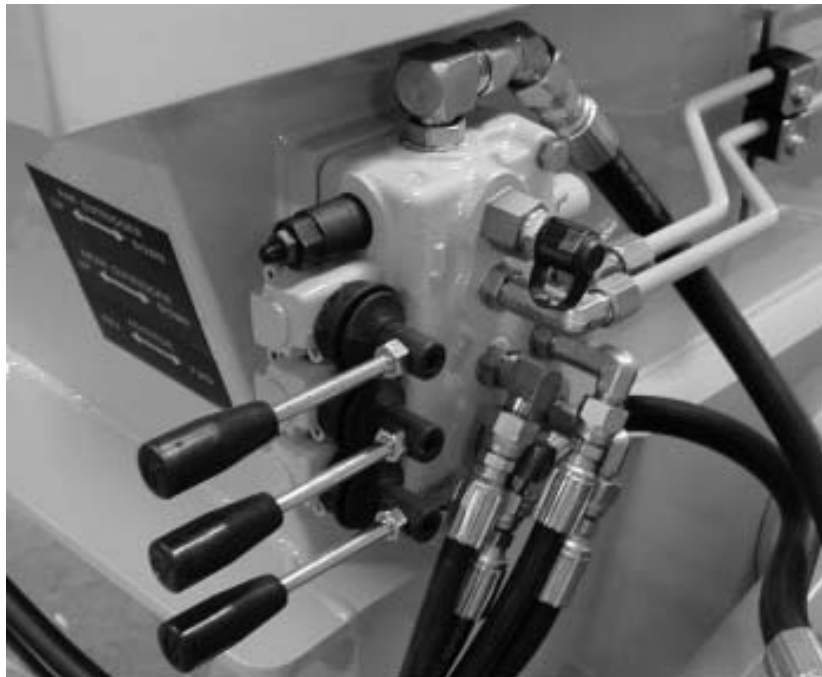

REED**REED MODEL: B20
TRAILER CONCRETE PUMP****ADJUSTMENT PROCEDURES**

It is not unusual that over a period of time due to usage, troubleshooting, making repairs or replacement of parts that certain components may require periodic adjustments to maintain the factory type performance. This section of the manual is offered to assist you in making the necessary adjustments.

ADJUSTMENTS TO HYDRAULIC SYSTEM

The **MODEL B20** concrete pump has undergone an extensive quality control inspection and testing phase during the manufacturing process prior to being shipped. All the required settings and adjustments to provide an efficient and safe operating machine have been made. The various pressure settings and adjustments should **NOT BE ALTERED**. However, it may be necessary through the course of using the machine or replacement of parts to check and reset the pressure settings to the factory established guidelines. This should only be done by **QUALIFIED MAINTENANCE PERSONNEL** who understand the systems. The following is offered to assist in accomplishing the task.

NOTE

The unit is equipped with a test port which is used to install a test gauge. To perform the following checks and adjustments, the following test gauges may be required.

TEST GAUGE #1 - This test gauge consists of a small diameter hose having one end connected to a 0-1000 PSI (0-70 Bar) hydraulic pressure gauge and the other end containing a female adapter.

TEST GAUGE #2 - This test gauge consists of same set up as **GAUGE 1** except the gauge is a 0-6000 PSI (0-420 Bar) hydraulic pressure gauge is used.

The **TEST GAUGE KITS** are available from the **REED** Parts Department.



**REED MODEL: B20
TRAILER CONCRETE PUMP**

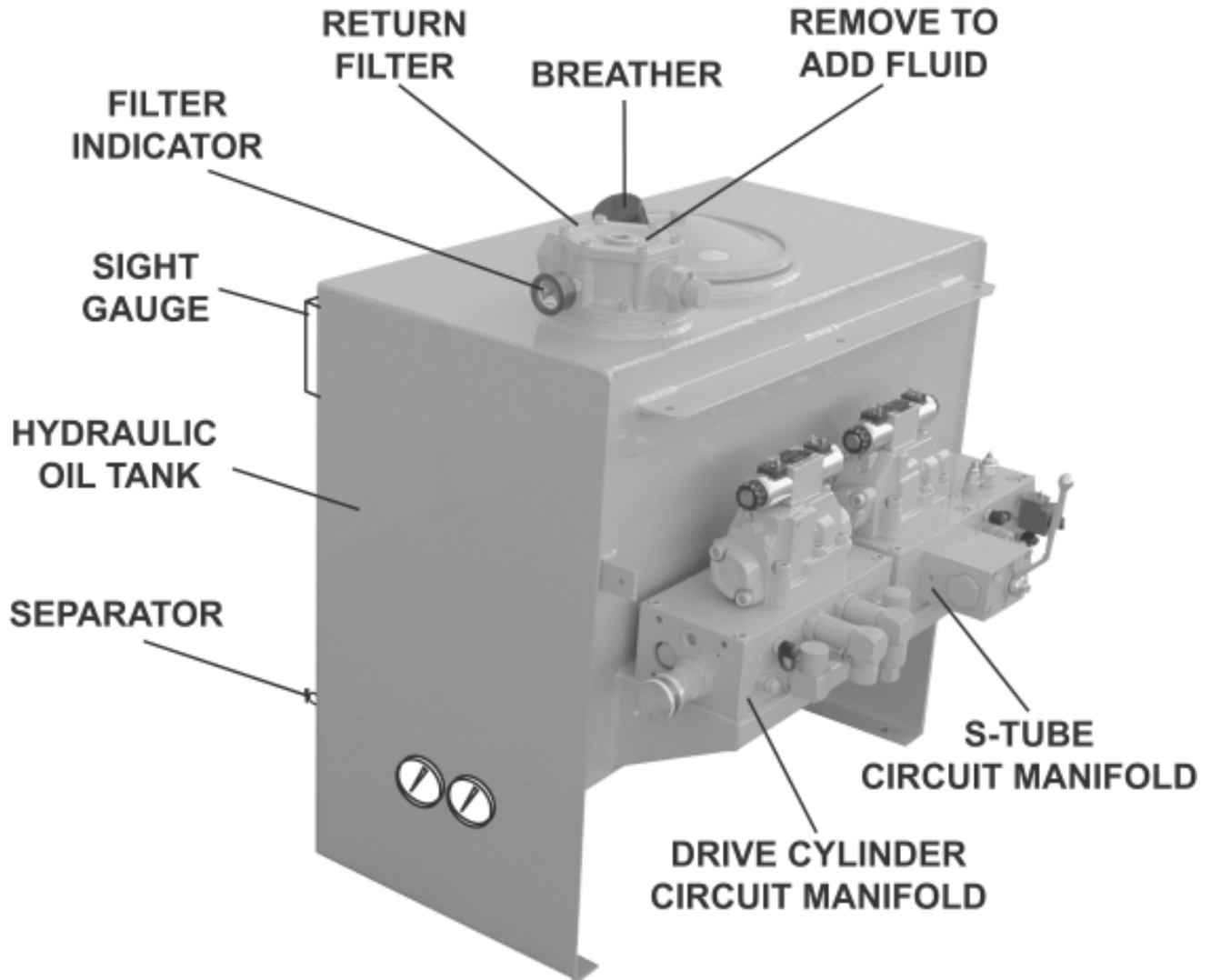

1. STAND BY PUMP PRESSURE (230-290 PSI/16-20 BAR)

Located on the manifold block near the volume control is a test port. Shut off engine. Remove cap from the test port and install **TEST GAUGE #1**. (IF REQUIRED)

A. CHECKING THE PRESSURE

- Start engine and adjust **THROTTLE** to maximum RPM.
- Adjust **VOLUME CONTROL**, so that it is completely closed, turn **CLOCKWISE**.
- Pressure gauge should read 230-290 PSI.
- If pressure indicated does not fall within specified range then an adjustment is necessary.

⚠ WARNING

DO NOT ACTUATE PUMP SWITCH. To do so will damage test gauge.

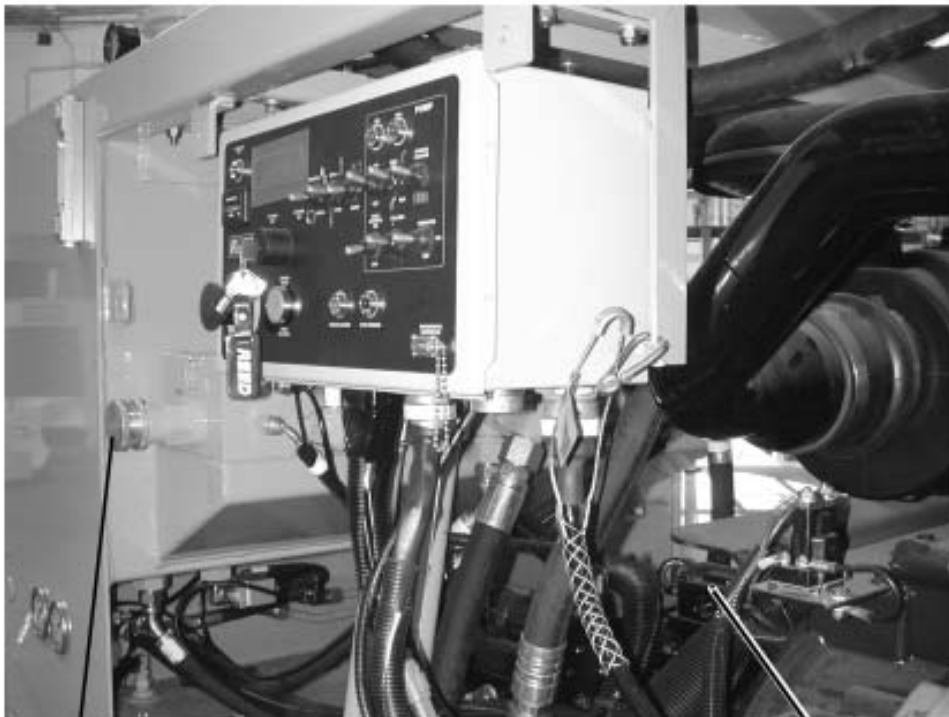

CONTROL BOX WITH COVER REMOVED

VOLUME CONTROL

MAIN HYDRAULIC PUMP



REED MODEL: B20 TRAILER CONCRETE PUMP

MAINT

PAGE 26

B. SETTING RELIEF PRESSURE

- **TEST GAUGE #1** can remain installed and engine can remain running.
- Remove cap from Standby Pressure adjustment screw on main hydraulic pump. This will expose the adjustment screw. Loosen locknut.
- Using a #3 Metric Allen Wrench, turn screw **IN** to **INCREASE** pressure and turn **OUT** to **DECREASE**.
- Make adjustment in small increments and monitor gauge.
- After pressure has been adjusted to proper setting, tighten locknut and replace cap.
- Turn engine **OFF**. Remove **TEST GAUGE #1** and cap test port.

2. MAIN SYSTEM (4000 PSI/280 BAR) RELIEF PRESSURE (4250 PSI/298 BAR)

The adjustment of the main system pressure is done at the pump and the relief is located at the front side of the manifold block.

A. CHECKING THE PRESSURE

- Shut off engine. Remove cap from the test port located on manifold block near the volume control.
- Remove the cap from the pressure compensator adjustment screw on the hydraulic pump. This will expose the adjustment screw. Loosen locknut.
- Start engine and adjust **THROTTLE** to maximum **RPM**. Turn **VOLUME CONTROL** full **ON**.
- Using a #3 Metric Allen Wrench, turn compensator adjusting screw **IN** about one and one-half turns. This will increase pressure to greater than relief valve setting.
- Turn **PUMP** switch **ON**, allowing pump to cycle. Actuate **CYL** switch to either "**A**" **OR** "**B**" and hold.

REVISION:

- Monitor **TEST GAUGE** or gauge on side of tank. They both should read 4250 PSI/ 298 Bar. Release switch and turn **PUMP** switch **OFF**.
- If pressure on gauge does not read 4400 PSI (303 Bar) then an adjustment is necessary.

⚠ WARNING

DO NOT ACTUATE PUMP SWITCH. To do so will damage test gauge.

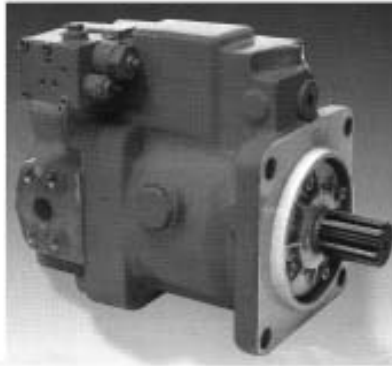
SWASH-PLATE TYPE AXIAL PISTON PUMP**B. SETTING RELIEF PRESSURE**

- The relief valve is located on the forward side of the manifold block. Loosen the locknut on the relief.
- Start engine, adjust **THROTTLE** to maximum **RPM** and set **VOLUME** control full **ON**.
- Turn **PUMP** switch **ON** and actuate **CYL** switch to either “**A**” or “**B**” and hold.
- Using an Allen Wrench, adjust set screw until gauge reads 4400 PSI (303 Bar).
- Release switch and turn **PUMP** switch to **OFF** position.
- Tighten locknut at relief valve.

C. SETTING MAIN SYSTEM PRESSURE (4000 PSI/280 BAR)

After setting the relief pressure, it will be necessary to reset the main system pressure so that it is lower than that of the relief pressure.

- With engine running at maximum **RPM** and **VOLUME** control full **ON**, turn **PUMP** switch **ON**.
- Actuate **CYL** switch to either “**A**” or “**B**” and hold.
- Using an Allen Wrench, adjust compensator adjusting set screw **OUT** to decrease pressure until gauge reads 4000 PSI (276 BAR).
- Release switch, turn **PUMP** switch **OFF** and shut down engine.
- Remove **TEST GAUGE #2** and cap test port.

3. SHIFT CIRCUIT SYSTEM PRESSURE - SET @ 2000 PSI/140 BAR SHIFT RELIEF PRESSURE - 2300 PSI/160 BAR

The S-Tube Shift Circuit manifold is located on the back side of the tank. It contains the relief and unloader valve. These cartridge valves are used to protect and limit the pressure being applied to the accumulator and are used to adjust and set the **SHIFT** system pressure. To check and adjust the pressure the following is offered:

A. CHECKING THE RELIEF PRESSURE

- Start engine and adjust **THROTTLE** to maximum RPM.
- Turn **VOLUME** control so that it is partially open.
- Loosen locknut on the unload cartridge valve.
- Using an Allen Wrench, turn set screw all the way **IN**.
- Monitor the accumulator pressure gauge. Gauge should read 2400 PSI(166 BAR). This indicates the **RELIEF VALVE** setting. If gauge reads otherwise, then an adjustment is necessary.

B. SETTING SHIFT CIRCUIT PRESSURE

- Loosen locknut on **RELIEF VALVE**.

- Actuate **PUMP** switch to **ON** position.
- Monitor accumulator gauge while adjusting relief set screw **IN** to increase pressure or **OUT** to decrease pressure so that gauge reads 2400 PSI(166 BAR).
- Shift **UNLOADER** valve will also need to be reset. With Allen Wrench, adjust set screw OUT until pressure on gauge reads 2000 PSI.
- With adjustment made, tighten locknut on **UNLOADER**.

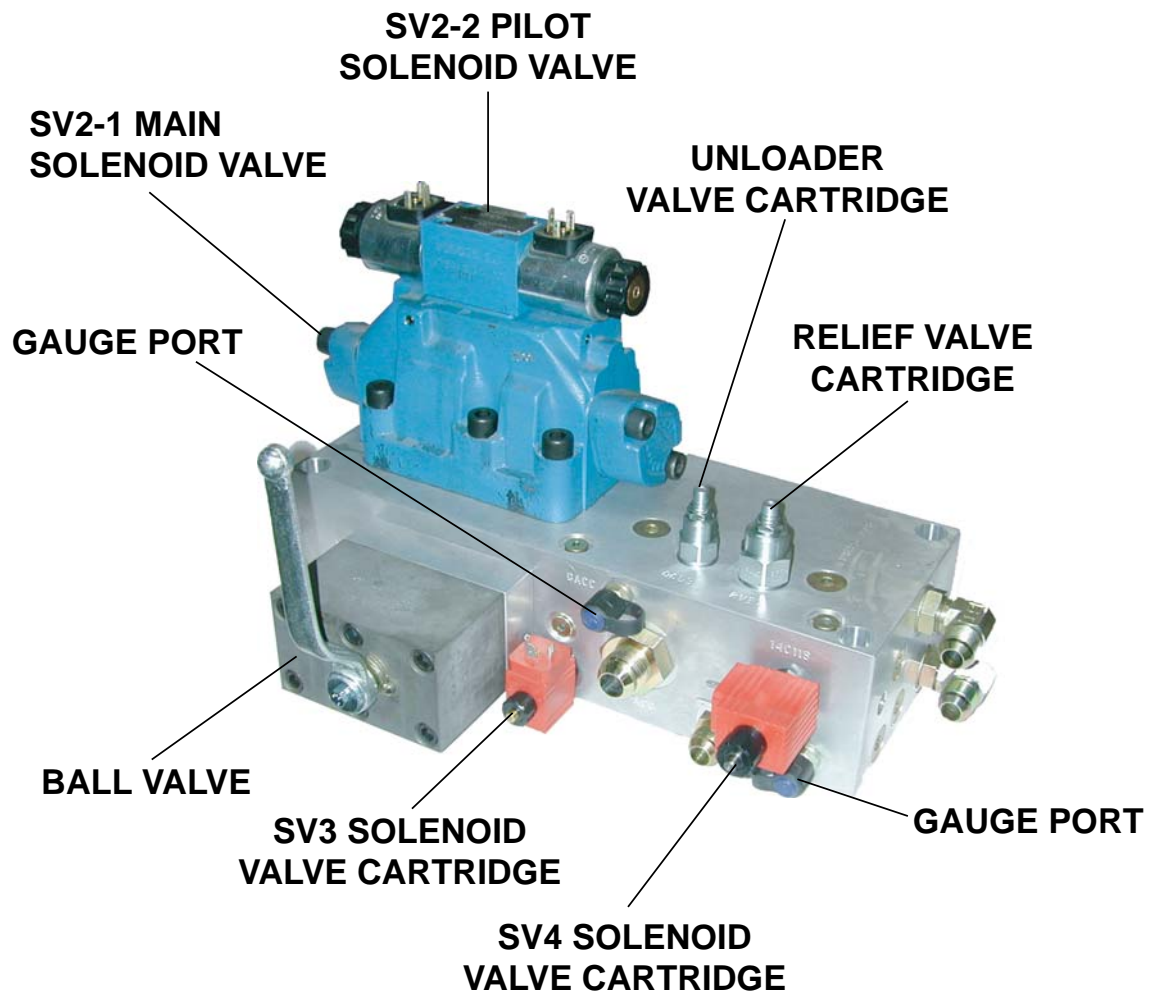

4. AUXILIARY CIRCUIT RELIEF

This auxiliary circuit for the **MODEL B20** is used to operate the agitator function. In this circuit, the relief valve set pressure and the system operating pressure is the same. To check and make an adjustment the following is offered:

Agitator Pressure - Set @ 1000 PSI (83 Bar)

To check or set this pressure, it will be necessary to install a test pressure gauge in the system.

- Turn off pump and engine.
- Slowly loosen hose fitting at hydraulic motor and then disconnect hose. Plug or cap end of hose securely against pressure.
- Install in the motor a 3000-PSI pressure gauge directly or attach the gauge to a test hose and install other end in motor.
- Start engine and adjust **THROTTLE** to maximum **RPM**.
- At control, actuate the directional control valve lever to either **FWD** or **REV** which would be the direction that still has pressure hose connected. (Not gauge side)
- Monitor pressure gauge. Gauge should read 1500 PSI (83 BAR).
- If gauge reads higher or lower, the readjust relief valve as follows:
 - The relief valve is located in the directional control valve.
 - Loosen locknut on valve cartridge. Turn set screw **IN** to increase pressure and **OUT** to decrease pressure.
 - When correct pressure is reached, tighten locknut.
 - Shutdown engine.
 - Disconnect pressure gauge and reinstall hose onto motor.

ADJUSTMENT TO SWING TUBE

It is important from an operational standpoint that the swing tube shift properly from side to side and that it is properly adjusted to prevent leakage particularly at high pressure and high volume pumping. On a properly adjusted swing tube, the shifting motion from one material cylinder to the other shall be smooth providing a very light scraping noise. The gap between the swing tube and the wear plate installed on the hopper shall be almost nonexistent, but not so tight that it impedes a smooth movement.

Located inside the swing tube is a wear ring and it is designed to stay continually in contact with the wear plate providing the necessary sealing action for efficient operation. This is the scraping noise that should be heard. If there is a lack of the scraping noise or the swing tube shifts too freely this is usually the first indication that an adjustment is required.

To adjust the swing tube clearance:

- Shut off engine. If unit was being run, allow a few minutes for the accumulator pressure to subside.
- Remove cotter pin from large castle nut on swing tube shaft.
- Tighten the castle nut approximately on-half turn
- Start engine and adjust **THROTTLE** to a low **RPM**.
- Honk **HORN** to **RESET** on panel, turn **PUMP** switch to **ON** swing tube to shift from side to side a few times.
- If the scraping noise of the swing tube is slight and the tube shifts briskly from side to side, the adjustment is correct.
- If further adjustment is necessary, activate **E-STOP** circuit and verify pressure gauges have reached **ZERO**, then tighten hex nut a little at a time. **DO NOT OVER TIGHTEN** or swing tube may bind while pumping material at high pressure.
- If the swing tube hesitates or stutters during the change over, the adjustment is too tight. Loosen lock nut a little at a time.
- Once adjustment is finalized, replace cotter pin and cover.



**REED MODEL: B20
TRAILER CONCRETE PUMP**

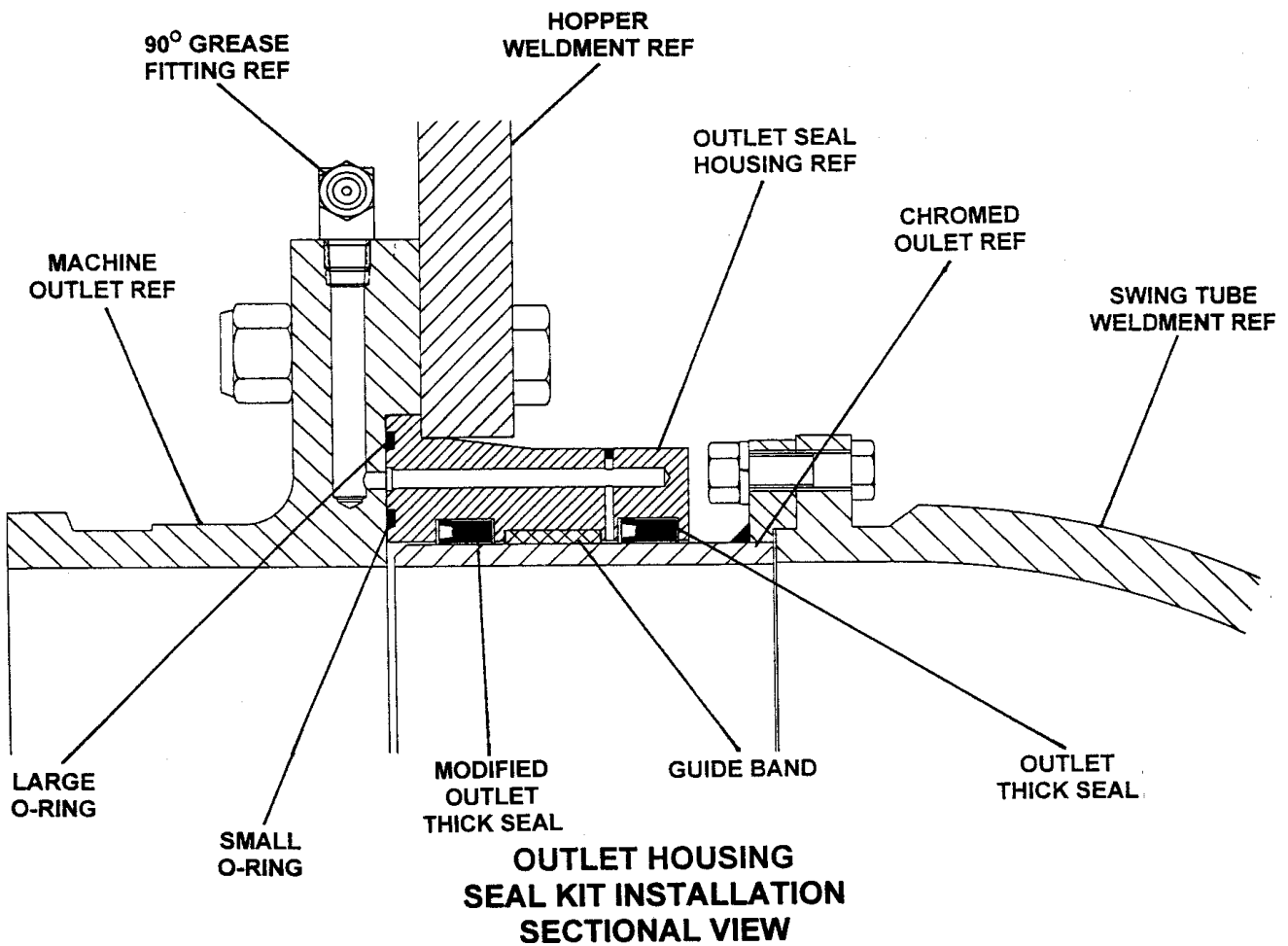

REVISION:



**REED MODEL: B20
TRAILER CONCRETE PUMP**

MAJOR COMPONENT REPLACEMENT

It is a given fact that due to usage, improper maintenance and environmental conditions that certain parts will wear out over a period of time and will need to be replaced to continue efficient operation. When tell-tell signs indicate that a part is worn, don not delay in the replacement. Continued usage with worn parts may lead to the damaging of other parts.

This section of the manual is provided to assist you in replacing some of the major components that may be worn. A step by step procedure is offered. Please be aware that the possibility exists your machine may be slightly different. If you find this to be the case, contact the **REED** Service Department. They will be pleased to assist you.

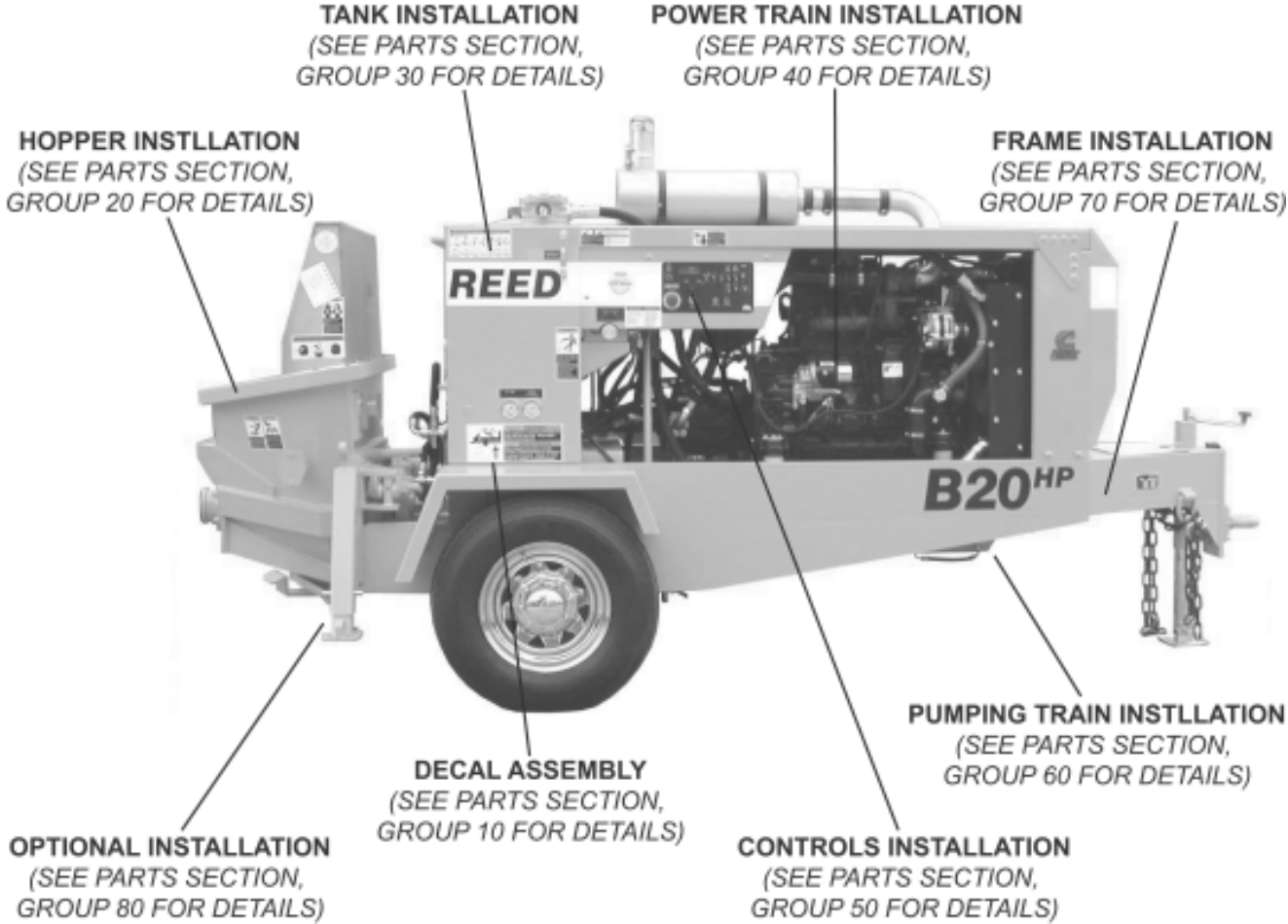

SWING TUBE & COMPONENTS

The sealing characteristics of the swing tube depends on metal to metal friction of the wear ring, located inside the swing tube, to the wear plate installed on the inside of the hopper at the material cylinders. This friction and the abrasiveness of the pumping material mixes will cause wear and a breakdown of the sealing action. As this breakdown occurs, periodic adjustments to the swing tube can be made as described in the **ADJUSTMENT SECTION**. This will help to improve the sealing quality, however, eventually the components will need to be replaced.

Some tell-tell signs or identifying symptoms that adjustment is needed or parts are worn might be:

- When deep grooves have developed on the face of the wear plate and/or on the wear ring.
- When the outlet volume at the end of the delivery line noticeably begins to decrease or eventually stops for no apparent reason.
- When the material being pumped is being forced back into the hopper under pressure.

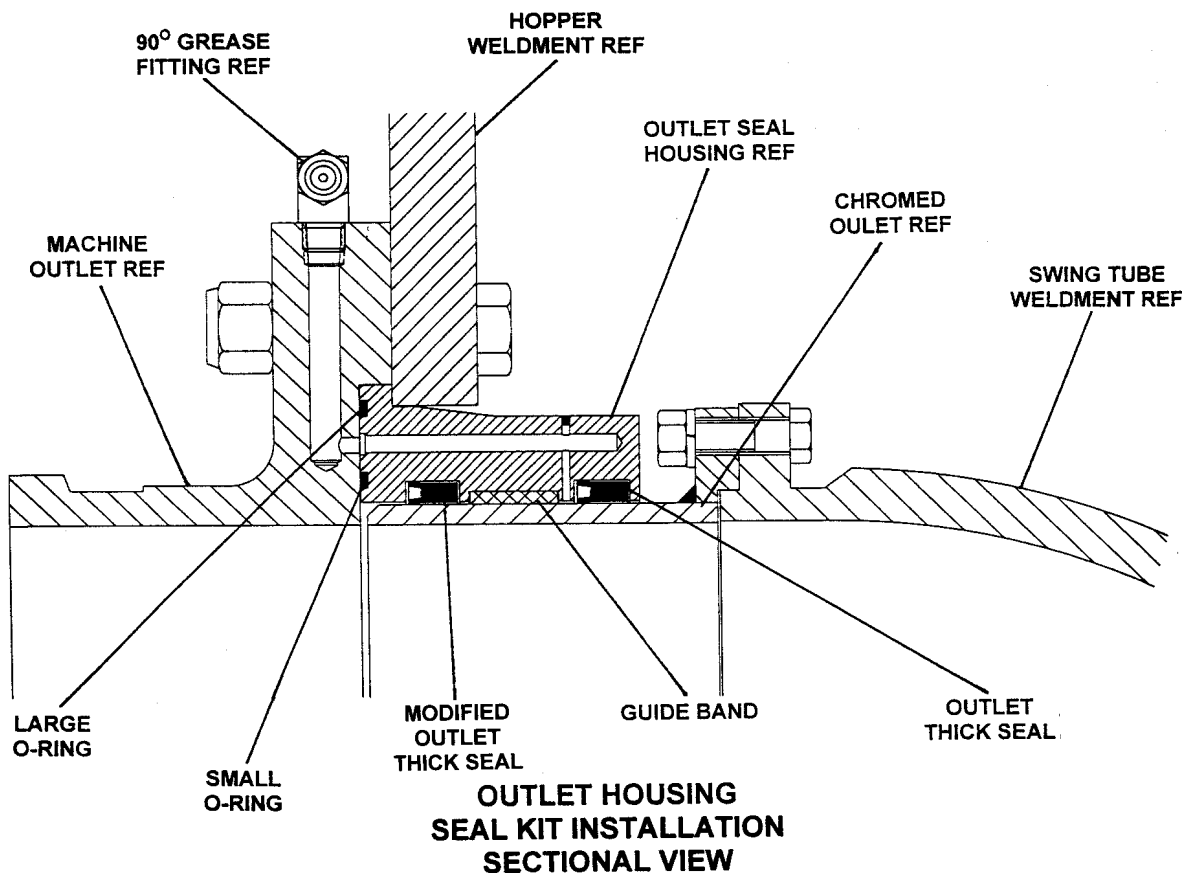

REVISION:



REED MODEL: B20 TRAILER CONCRETE PUMP

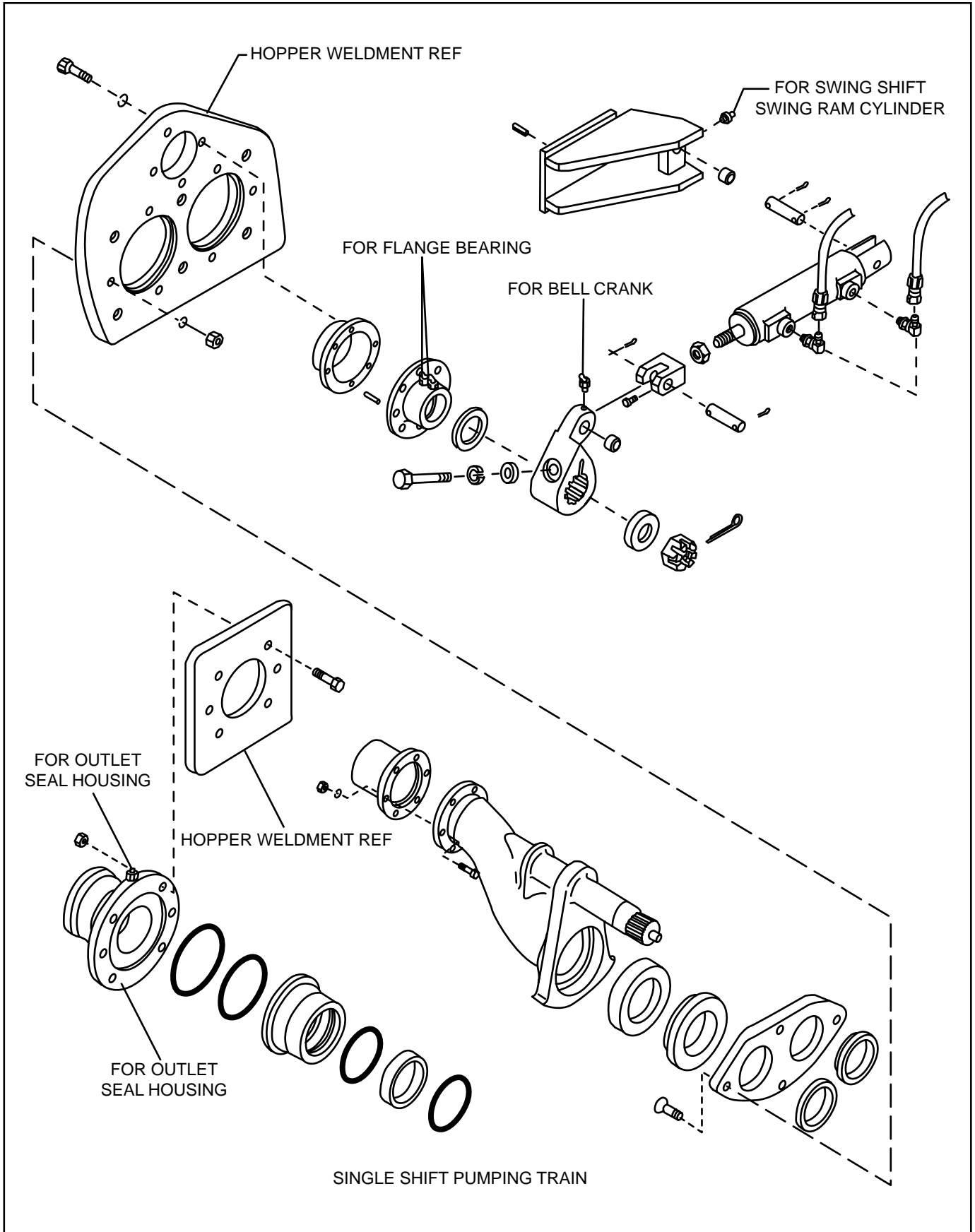

REVISION:



REED MODEL: B20 TRAILER CONCRETE PUMP

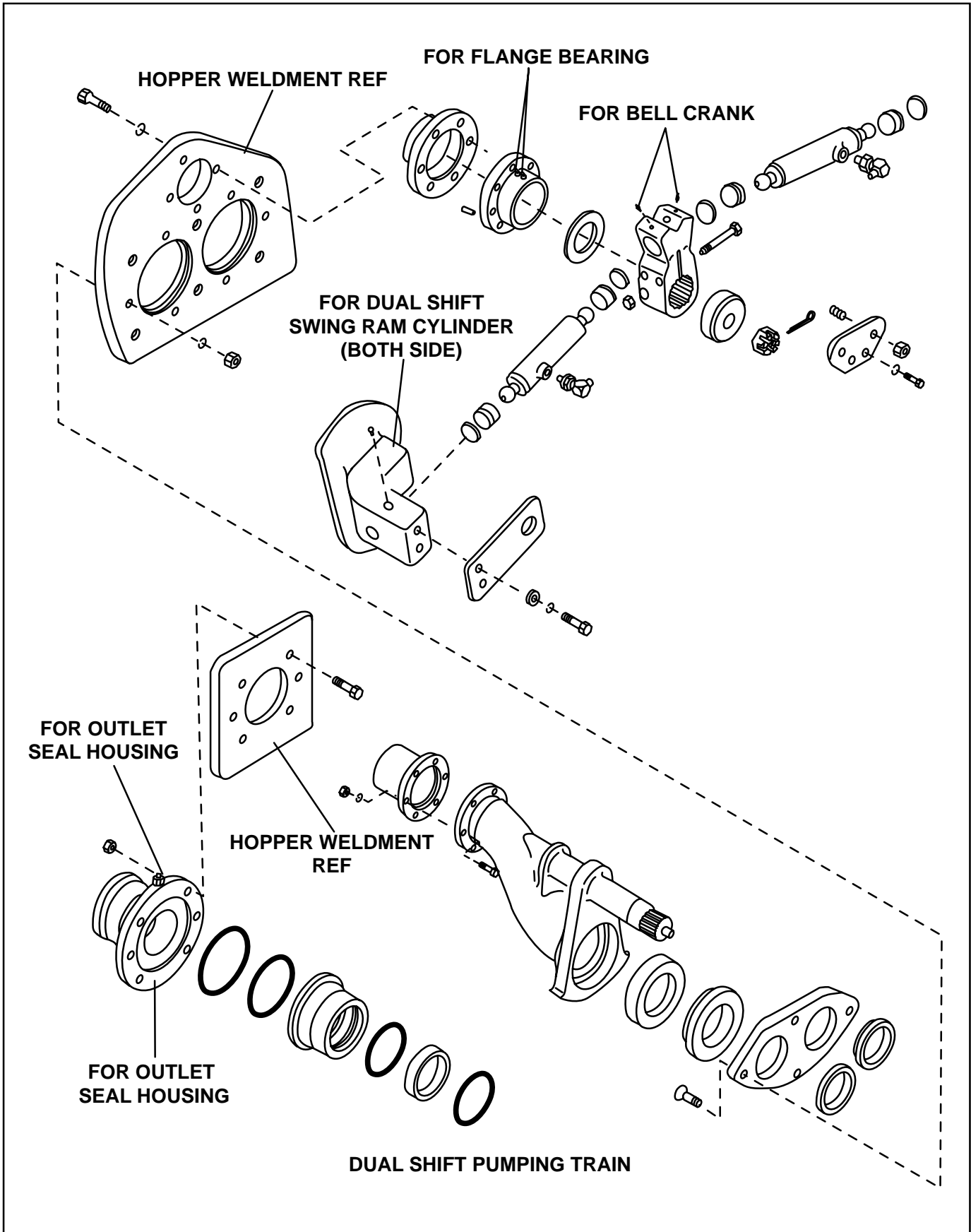

REVISION:



REED MODEL: B20 TRAILER CONCRETE PUMP

DO NOT ENTER THE HOPPER AREA WITH ANY PART OF YOUR BODY UNLESS THE EQUIPMENT IS COMPLETELY OFF (engine must be OFF and all hydraulic circuits must be ZERO).
*Refer to Maintenance section to find description of Pressure Gauges (in "Description of Hydraulic System" section) in order to verify that hydraulic pressure is zero.

WEAR RING AND WEAR PLATE REMOVAL/REPLACEMENT

- Turn off engine to shut down the system. **BE SURE ACCUMULATOR PRESSURE IS RELEASED.**
- Unbolt outlet flange from hopper and remove, being careful not to damage any of the seals and o-rings.
- Remove the cover over the shift cylinder and bell crank.
- At the bell crank, remove cotter pin, castle nut, bell crank, and shift cylinder.
- Place a sling from an overhead hoist around the discharge end of swing tube to help support the tube.
- Work swing tube back toward the outlet. It may be necessary to nudge it with a pry bar. **EXERCISE CARE.** The swing tube only needs to be moved toward the outlet a sufficient distance to enable wear ring to be replaced.
- Remove wear ring and thrust ring from inside of swing tube.
- If it is necessary to replace the wear plate, this can be accomplished by backing out the mounting bolts located on the outside back the hopper. The bolts only have to be backed out a sufficient distance to enable wear plate to be removed. Maneuver the wear plate up through the gap between swing tube and hopper.
- Carefully clean the inlet end of the swing tube where the thrust ring and wear ring will sit. Also clean the surface of the hopper where new wear plate will be installed.
It is also recommended to replace the anti-chip rings when replacing wear plate.

RE-ASSEMBLY

- Apply a small bead of silicone to back side area of new wear ring and thrust ring. Install thrust ring and wear ring into swing tube.
- Slide the new wear plate down between the swing tube and hopper. Reinstall and tighten the bolts.
- Slide swing tube forward until wear ring is set against wear plate.
- Install outlet flange assembly being careful not to damage any of the seals. Tighten bolts.
- Reinstall bellcrank parts, shift cylinder, and castle nut. Remove sling.
- Adjust the swing tube. Refer to procedure outlined in **ADJUSTMENT SECTION.**

REVISION:



REED MODEL: B20 TRAILER CONCRETE PUMP

DO NOT ENTER THE HOPPER AREA WITH ANY PART OF YOUR BODY UNLESS THE EQUIPMENT IS COMPLETELY OFF (engine must be OFF and all hydraulic circuits must be ZERO).
*Refer to Maintenance section to find description of Pressure Gauges (in "Description of Hydraulic System" section) in order to verify that hydraulic pressure is zero.

SWING TUBE REPLACEMENT

The swing tube, like the wear plate and wear ring, is considered a wear item, meaning that it will eventually need to be replaced. When this situation is encountered, the following is offered to assist you in accomplishing the replacement.

NOTE

The removal of the swing tube involves the disassembly of several other wear components. It is suggested that these be replaced as well.

REMOVAL

- Turn off engine to shut down the system. **BE SURE ACCUMULATOR PRESSURE IS RELEASED.**
- Unbolt and remove outlet flange, seal housing and chrome outlet from tube and push outlet as far as possible toward hopper.
- Remove the cover over the shift cylinder and bell crank.
- At the bell crank, remove the cotter pin, castle nut, bell crank, shift cylinder, and flange bearing.
- Place a sling from an overhead hoist around the discharge end of the swing tube to help support the tube.
- Maneuver and work the swing tube toward the hopper outlet as far as it will go or until end of shaft is inside hopper.
- Using the hoist and sling, lift swing tube out of hopper.

RE-ASSEMBLY

Before reassembly of the swing tube this is a good opportunity to clean out hopper of cured material, replace wear plate or do any maintenance on the material cylinders.

It is recommended that when the swing tube is replaced that all seals on the outlet and bearing housing be replaced as well as any other wear items. This is good preventative maintenance.

REED**REED MODEL: B20
TRAILER CONCRETE PUMP**

DO NOT ENTER THE HOPPER AREA WITH ANY PART OF YOUR BODY UNLESS THE EQUIPMENT IS COMPLETELY OFF (engine must be OFF and all hydraulic circuits must be ZERO).
 *Refer to Maintenance section to find description of Pressure Gauges (in "Description of Hydraulic System" section) in order to verify that hydraulic pressure is zero.

- Reassemble the swing tube and components in basically the reverse order used in disassembly. Some important items to be noted are:
 - Make sure all components that are to be reused are cleaned from any residual material or grease.
 - Inspect all parts for damage such as nicks, scratches etc.
 - Smear a small amount of clean grease on all seals, polypacks and O-rings before installing.
 - Pay particular attention to the position and direction of seals when installing.
 - Make sure all bolts and nuts are tight.
 - Lubricate as required.
 - Test movement of swing tube and make necessary adjustments following the procedure noted in the **ADJUSTMENT SECTION**.

MATERIAL CYLINDER COMPONENTS

Two (2) material cylinders powered by two (2) hydraulic drive cylinders are arranged in the system to operate alternately. While one cylinder is drawing material into the cylinder tube from the hopper on the retraction stroke, the other cylinder is pushing the material out the swing tube and discharge on the forward stroke. Because of the abrasiveness of the material being pumped, it will be necessary to periodically replace the piston cups.

Some tell-tell signs and identifying systems of worn parts might be:

- A slurry of the material being pumped starts to appear in the flush box.
- The water or lubricating oil, if used, begins to rapidly lower the level without any sign of leakage from the box.
- Operation of the cylinder is rough and erratic.

⚠ WARNING

Be sure pressure in accumulator shift circuit has been released before doing any work inside the hopper or inside the flush box.

DO NOT ENTER THE HOPPER AREA WITH ANY PART OF YOUR BODY UNLESS THE EQUIPMENT IS COMPLETELY OFF (engine must be OFF and all hydraulic circuits must be ZERO).
*Refer to Maintenance section to find description of Pressure Gauges (in "Description of Hydraulic System" section) in order to verify that hydraulic pressure is zero.

⚠ WARNING

Do not place hands in the water box or in adjacent area while motor is running. Always check that the pressure in the accumulator has been released before performing any work.

PISTON CUP REMOVAL/REPLACEMENT

- Cycle machine using appropriate controls until one of the cylinders is at full extension. Jog swing tube so that it is shifted over to other cylinder. This will expose fully extended piston.
- Turn off engine and allow pressure to subside.
- Remove the four (4) 3/8 – 20 x 1½" long bolts and lockwashers securing the piston plate, and piston cup to the piston adapter.
- Pry out the old piston cup and plate. Clean piston plate and inspect piston adapter, and clean if needed.
- Apply a good amount of grease on lip of piston cup. Tip should be facing hopper. Insert two (2) 3/8 – 20 x 4 long bolts through piston plate and cup in opposite holes. This will allow you to locate the cup in a correct position for lining up the holes.
- Screw the bolts by hand into the piston adapter. Start the piston cup into the cylinder and using a wooden dowel, tap the piston plate which will force the piston cup into the material cylinder.
- With the cup against the adapter, insert two (2) of the original 3/8 – 20 x 1½" long bolts and tighten. Remove the two (2) long bolts and replace with the originals

Replace piston cup in other cylinder in the same manner.



REED MODEL: B20 TRAILER CONCRETE PUMP

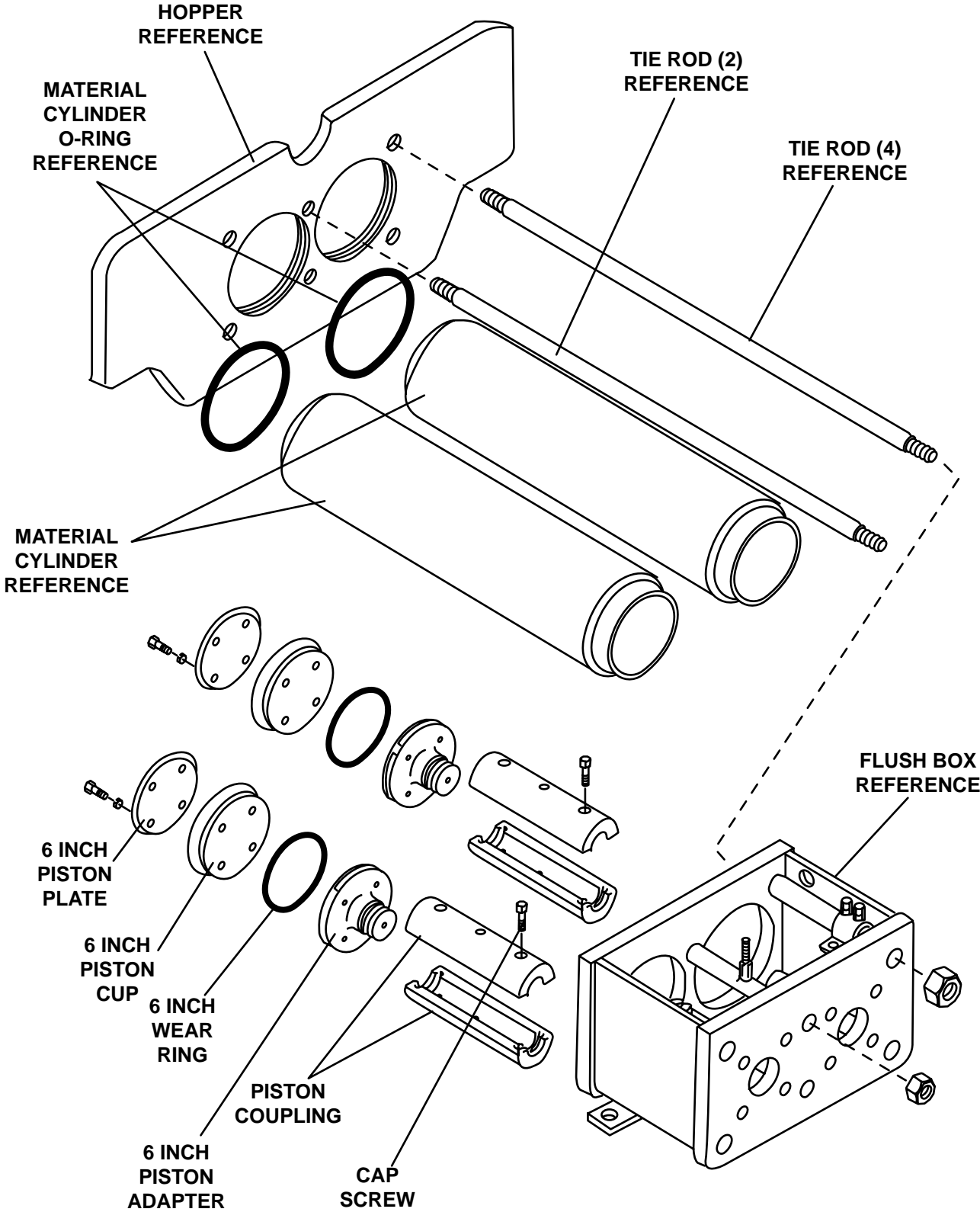

REVISION:



REED MODEL: B20 TRAILER CONCRETE PUMP

MAINT

PAGE 42

PISTON ADAPTER O-RING REMOVAL/REPLACEMENT

Installed on the piston adapter, is an o-ring that is used as a second seal for the material cylinders. This o-ring will need replacing and a tell-tell sign is if the material cylinders only partially fill with material. This o-ring cannot be replaced from the hopper end, but must be replaced at the flush box end. To change the piston adapter o-ring, the following is offered:

- Cycle machine until one of the cylinders is completely retracted. Turn off engine and allow the pressure to subside.
- Drain all oil or water from the flush box.
- As a precaution, mark location of proximity sensor adjusting bracket. Remove proximity sensor cross bracket.
- Mark the end of the piston coupler so that on reassembly, it can be placed in the same relation.
- Unbolt and remove top half of coupler. Pull the piston assembly toward you.
- Inspect piston cup, clean up or if necessary replace.
- Remove old o-ring from adapter and smear some clean grease on the new o-ring. Install on adapter.
- Place piston cup assembly into material cylinder at an angle so that center of adapter is angling toward bottom of flush box.
- Pull up on adapter to square up piston assembly.
- Install coupler halves and bolt together.

Follow same procedure to remove and replace o-ring on the other cylinder. After this installation proceed to:

- Replace proximity sensor cross bar and check position of adjustment bracket to previous mark.
- Refill flush box with water or oil.

REVISION:

ACCUMULATOR

It was noted in the **S-TUBE SHIFT CIRCUIT** description that the S-tube must shift alternately from one cylinder to the other in a synchronized operation. In addition this shift must be almost simultaneous. This instant pressure and volume cannot be provided by the system itself. To compensate for this an accumulator is used.

This is made up with an outer shell or tank, a rubber bladder installed inside the shell, a gas valve with port on top of the shell and a fluid port at the bottom of the shell complete with the necessary valves and seals.

To successfully work in the system and do the job intended the accumulator must first be pre-charged. The operation involved the induction of **DRY NITROGEN GAS** into the bladder to a pressure of 1250 PSI (87.5 BAR). This pressure will vary with each **REED** pump. Check the specifications noted in **MAINTENANCE SECTION, HYDRAULIC DESCRIPTION CHAPTER** of the appropriate manual. This dry nitrogen gas is inserted prior to installation of the accumulator and is used to inflate the bladder much like a balloon.

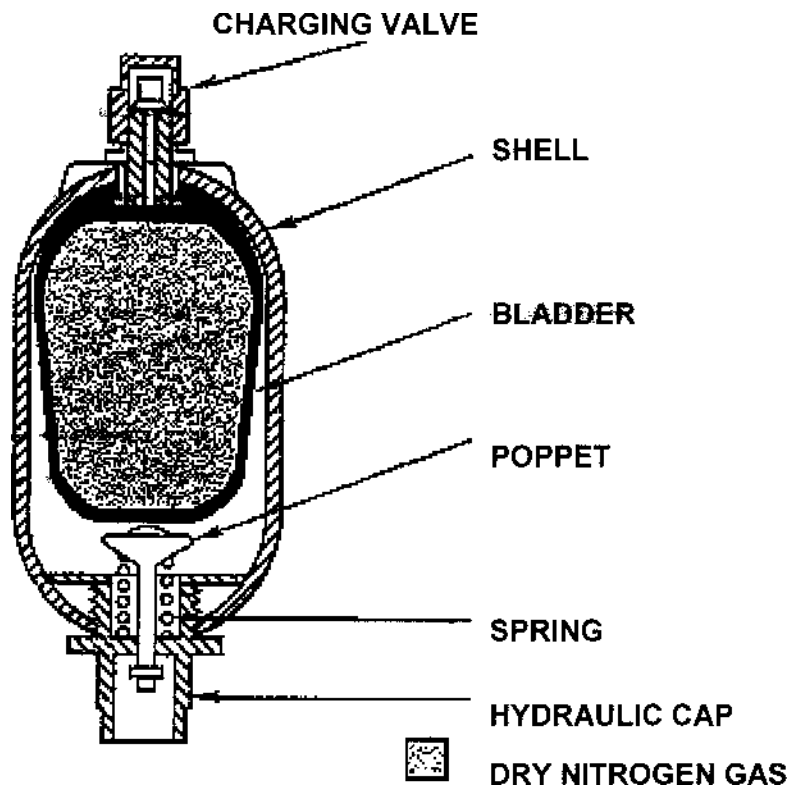

In operation of the accumulator in the hydraulic system, hydraulic fluid enters the accumulator through the fluid port and fills the area at the bottom between the inner wall of the shell and bladder. The hydraulic fluid enters at a higher pressure, 2500 PSI (175 BAR) than the gas pressure inside the bladder. At the appropriate time in the pump cycle, the unloading valve of the shift circuit opens, allowing the fluid in the accumulator to be discharged and is directed to the shift cylinder. As soon as the fluid is dispersed the accumulator is refilled. This cycle is repeated time after time.

The accumulator is a critical component in the pump operation and at some point in time it will be necessary to service the accumulator which might involve recharging with nitrogen, maintenance or bladder replacement. The following is offered to assist you in accomplishing this repair.

⚠ WARNING

The hydraulic accumulator is a PRESSURIZED VESSEL and only QUALIFIED TECHNICIANS should perform the necessary repairs. Always drain the fluid COMPLETELY from the accumulator before performing any work on the component.

We recommend the following special tools to be on hand to facilitate any work being done on the accumulator:

- Charging & Gauge Unit
- Gas Valve Core Tool
- Spanner Wrenches
- Bladder Pull Rod
- Sockets 27mm & 36mm
- Blunt Flathead Screwdriver
- Soft Faced Hammer
- Torque Wrenches



ACCUMULATOR PART FAMILIARIZATION

- | | |
|-------------------------|-------------------|
| 1. Shell | 14. Anti Ext Ring |
| 2. Bladder | 15. Flat Ring |
| 3. Gas Valve Core | 16. O-Ring |
| 4. Lock Nut | 17. Spacer Ring |
| 5. Valve Seal Cap | 18. Locknut |
| 6. Valve Protection Cap | 19. Vent Screw |
| 7. O-Ring | 20. Seal Ring |
| 8. Nameplate | 21. Back Up Ring |
| 9. Fluid Port | |

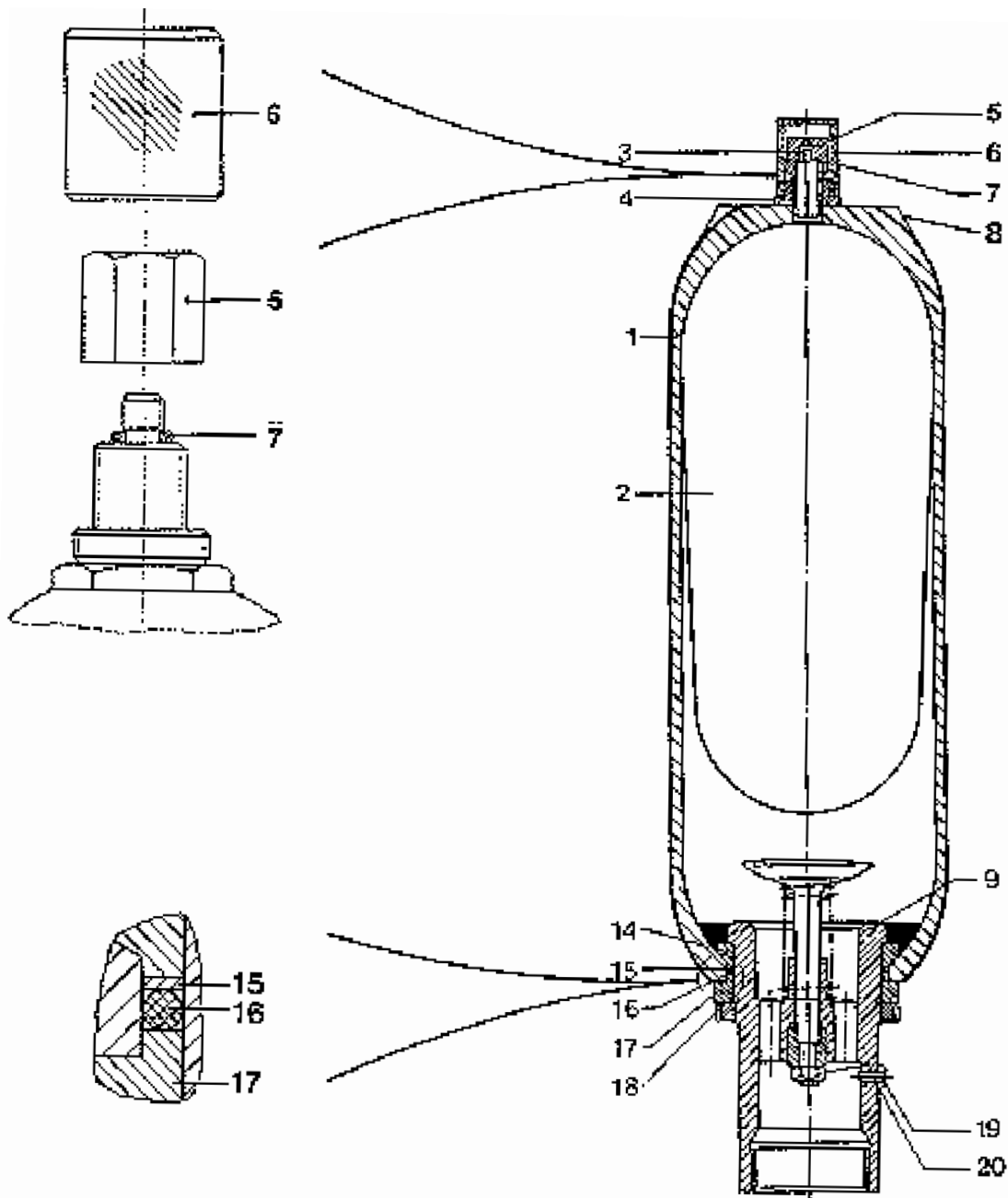

PRE-CHARGE PRESSURE

Pre-charge pressure as it relates to the accumulator is the insertion of dry nitrogen gas into the bladder, prior to installation or use. On a new machine the accumulator is pre-charged at the factory. When a replacement is shipped from the factory it is NOT PRE-CHARGED unless shipped by over land or ground. A charged accumulator is a pressurized vessel thus it is against the law to ship by AIR FREIGHT.

Periodically due to usage or leakage the bladder may loose some of the pre-charge which does affect the operation of the accumulator. As a result it is important that the pressure be checked at least once a year or when there is a noticeable change in the operation. The following is offered to assist you in servicing the accumulator.

NOTE

A Charging and Gauge Kit is required to perform maintenance on the accumulator. It is available from the REED Parts Department and you will find that it to be a good investment for your workshop.

CHECKING PRESSURE

Prior to checking of the accumulator pre-charge pressure the machine must be shutdown and all hydraulic pressure and fluid in the accumulator must be relieved.

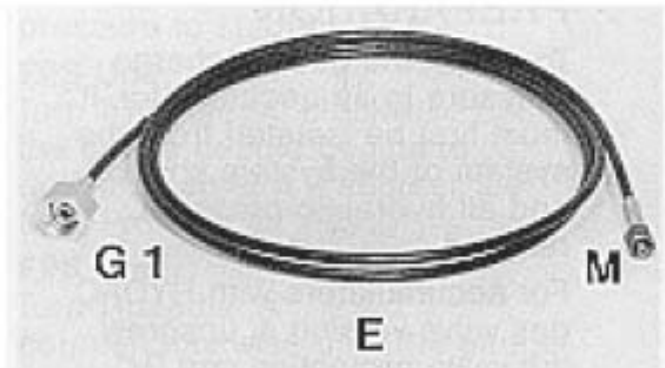
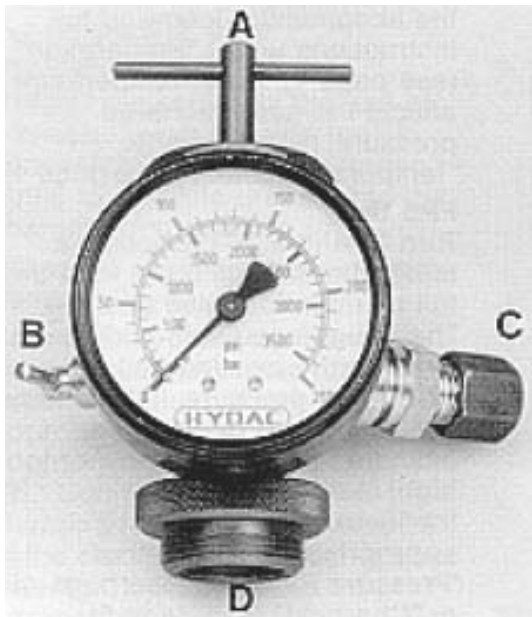



REED MODEL: B20 TRAILER CONCRETE PUMP

MAINT

PAGE 47

- Unscrew the valve protection cap #6 and valve seal hex cap #5. Exercise extreme care not to damage the O-ring #7 when removing the cap.
- Before making the installation of the gauge unit to the accumulator, turn the “T” handle counterclockwise until some resistance is felt. Check that the manual bleed valve is closed. If not closed, close valve hand tight.
- Install gauge unit on the accumulator by screwing the cap nut onto the gas valve. Hand tighten.
- Proceed to turn T-handle clockwise a maximum of 3 full turns from the full counterclockwise position.
- The gauge should then indicate the pre-charge pressure. Refer to specifications for correct pressure:
 - If pressure reading is **TOO LOW** then accumulator will need **RECHARGED**.
 - If pressure is **TOO HIGH** then it will be necessary to **RELEASE** pressure.

RELEASE OF PRESSURE

When gauge indicates that the pre-charge pressure is too high proceed as follows to release some of the pressure within the bladder.

- With gauging valve installed, carefully open the **MANUAL BLEED** valve, releasing some of the nitrogen gas.
- While doing this observe gauge until sufficient gas has been released and desired pressure has been reached.
- Close the manual bleed valve. Wait approximately 10 minutes for the pressure to stabilize, then recheck and if necessary adjust accordingly.
- To remove the gauging unit, turn “T” handle until resistance is felt to close the gas valve. Open the manual bleed valve.
- Disconnect the gauging unit by unscrewing the cap from the gas valve. Replace valve seal hex cap and tighten to 18 lb ft. Screw on valve protection cap, hand tight.

REVISION:

INCREASE PRE-CHARGE PRESSURE

In checking the pre-charge pressure if it is found to be too low then add nitrogen gas as follows:

- Install gauging unit as previously described. Turn “T” handle clockwise until needle on gauge begins to move then from this point turn it another full turn.

WARNING

***USE DRY NITROGEN GAS ONLY - NEVER USE OXYGEN OR AIR.
THIS COULD CAUSE AN EXPLOSION.***

- Connect the charging hose to the cap screw adapter and to the nitrogen bottle discharge. It is recommended that the commercial nitrogen bottle be equipped with a regulator to adjust pressure. Full pressure may damage gauge.
- Open the shut-off on the nitrogen bottle and slowly fill the accumulator. Charging too quickly may damage the accumulator.

NOTE

The gauge on the gauging unit during pre-charge registers the incoming line pressure and not necessarily the accumulator pressure while charging.

- The accumulator pressure can be checked by first closing the shut-off valve on the nitrogen bottle.
- Allow a few minutes for the temperature and pressure in the accumulator to stabilize.
- Check the accumulator pressure as previously described, then fill or release pressure as required.
- Close shut-off valve on the nitrogen bottle. Turn “T” handle counterclockwise to close gas valve.
- Open bleed valve, disconnect charging hose and remove gauging unit from accumulator. Reinstall hex cap and protective cap.

REPLACING THE ACCUMULATOR BLADDER

Because of the continuous inflation-deflation of the bladder, it is not uncommon that replacement of the bladder will be required. It is not difficult but time consuming as extra care must be exercised in disassembly-reassembly so as not to damage good reusable parts. The following is offered as suggested means of accomplishing bladder replacement.

DISASSEMBLY - Refer to Parts Identification page

- Remove the hydraulic connection at the base of the accumulator or at the fluid port. Then remove the mounting brackets.

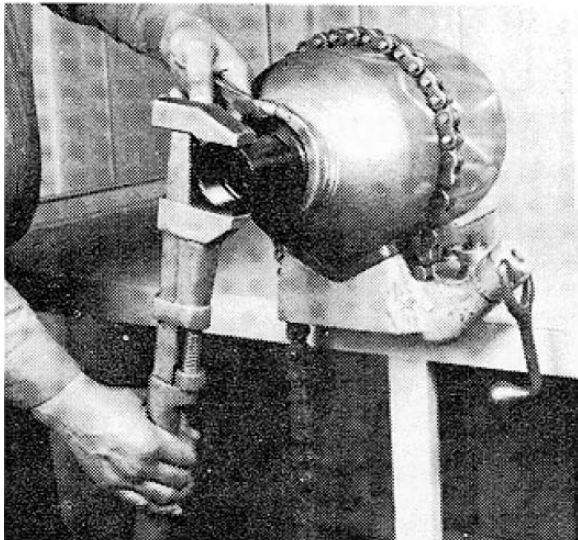

Photo A

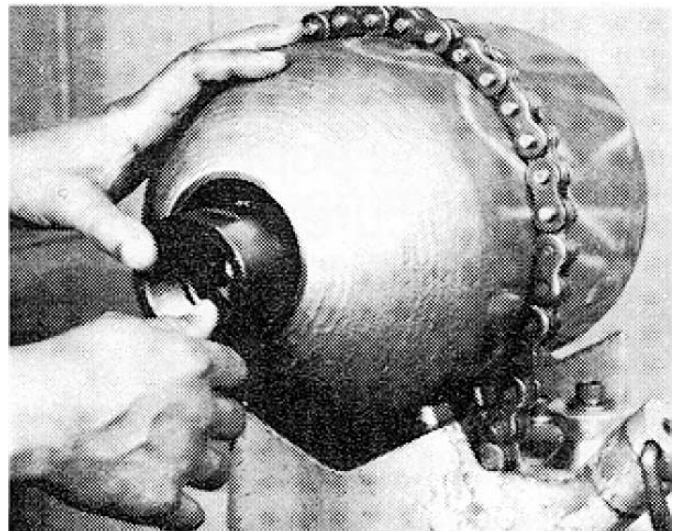

Photo B

- Place the accumulator in a vice or secure it to your work bench.

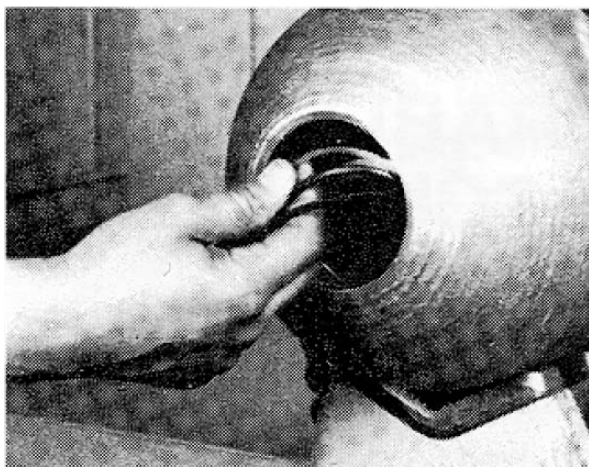
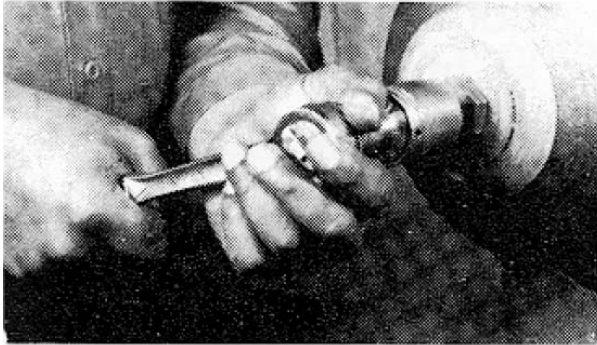
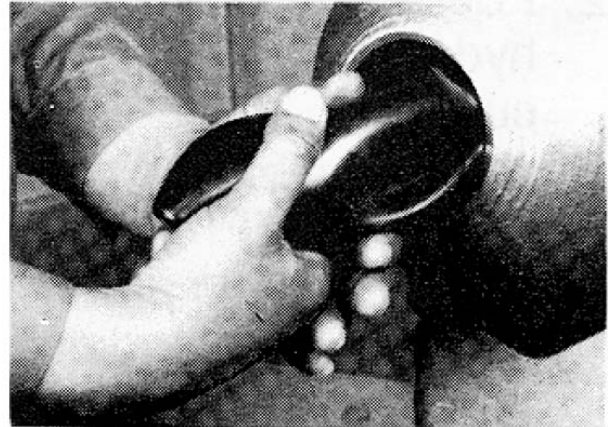

Photo C



Photo D

- Install the gauging unit to the accumulator after turning the “T” handle counterclockwise until a resistance is felt. Also close manual bleed valve, hand tight.

**Photo E****Photo F**

- After gauging unit has been installed, turn “T” handle clockwise a maximum of 3 full turns from the full closed position. The gauge will indicate the existing precharge pressure.
- Release the pressure by carefully opening the manual bleed valve. Remove gauging unit from accumulator.
- Using the core tool contained in the accumulator repair kit, remove the valve core #3 of the bladder.
- At the bottom of the accumulator, remove vent screw #19 and seal ring #20.
- Use a spanner wrench to remove lock nut #18 then remove the spacer ring #17.
- Loosen the fluid port #9 and push it into the shell. Remove the backup ring #21, O-ring #16, and flat ring #15 from the fluid port.
- Pull anti-extrusion ring #14 off the fluid port and by folding the ring in half remove it through the fluid side opening.
- Remove the fluid port #9.
- At the top of the accumulator remove locknut #4.
- From the fluid side remove the bladder #2. It may be necessary to fold the bladder lengthwise to remove it.

REASSEMBLY

Before proceeding to reassemble this accumulator it is recommended that the various parts be inspected for wear and damage. Replace as required. Also make sure that all parts are clean in particular the interior of the accumulator shell. To reassemble:

- Prepare replacement bladder for installation by removing the valve seal cap #5 and gas valve core #3. Press all residual air from bladder.
- Lubricate interior of shell and exterior of bladder with clean hydraulic fluid, Shell Tellus #46.
- Take the bladder pull rod from the kit. Put locknut #4 over the pull rod. Be sure male threads on locknut face the full rod handle.
- Insert the pull rod from top of accumulator through the shell with threaded connection toward fluid side.

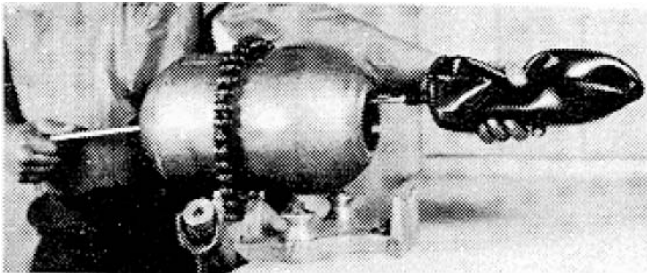

Photo E

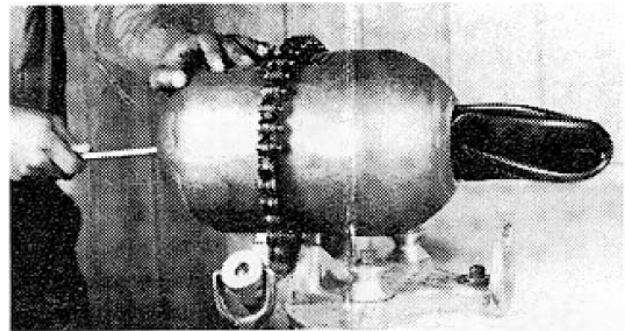
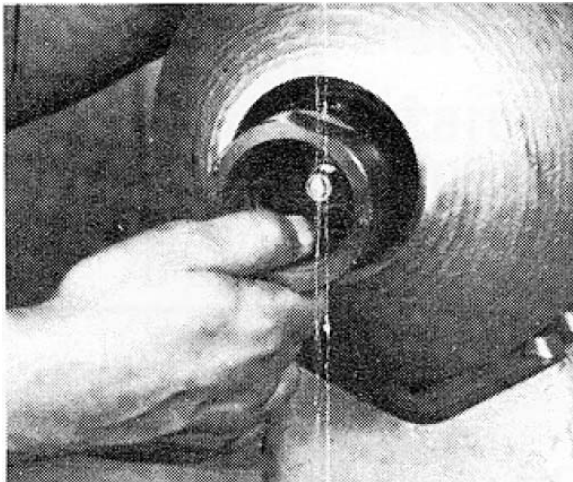
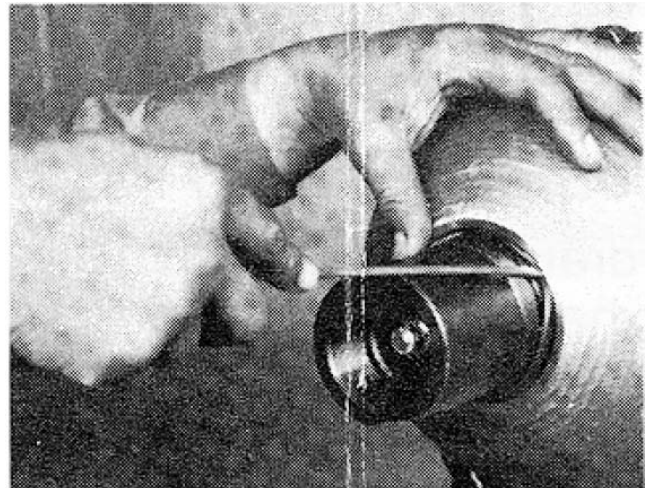

Photo F

- Thread pull rod onto bladder gas valve. Fold bladder in half lengthwise and again if necessary so that it can be easily inserted.
- Pull the rod through the top until gas valve emerges. Loosely attach locknut #4 to gas valve to prevent bladder from slipping back into shell. Remove rod from gas valve.
- Install gas valve core #3 and torque to 0.4 lb ft (0.5Nm).
- Insert fluid port #9 into shell. Exercise extreme care not to damage threads and O-ring. Make sure bladder is fully extended within shell.

- Fold anti-extrusion ring #14 in half and insert into shell with steel seat facing the fluid side opening. To do this push fluid port farther into shell and then pull it back through the middle to the extension ring.
- Slightly pull on the fluid port to prevent it from falling back into the shell while inserting the seals.
- Assemble items #15 float ring, #16 O-ring, #21 backup ring, #17 spacer ring, #18 locknut in that order.
- Insert flat ring #15 into space between fluid port and shell. If it does not slide on properly recenter fluid port in the opening.
- Next insert O-ring #16 by pressing gently with a blunt flathead screwdriver (with rounded edges) at 90 degree intervals. Carefully level O-ring onto seat.
- Where applicable insert backup ring #21 over O-ring with grooved surface towards O-ring.
- Insert spacer ring #17 with "lip" placed in the shell. Thread on locknut #18 and torque using spanner wrench. Place seal ring #20 on vent screw #19 and install in fluid port.

**Photo I****Photo J**

- On top side of accumulator, remove loosely attached locknut #4 and install nameplate. Install locknut and tighten.

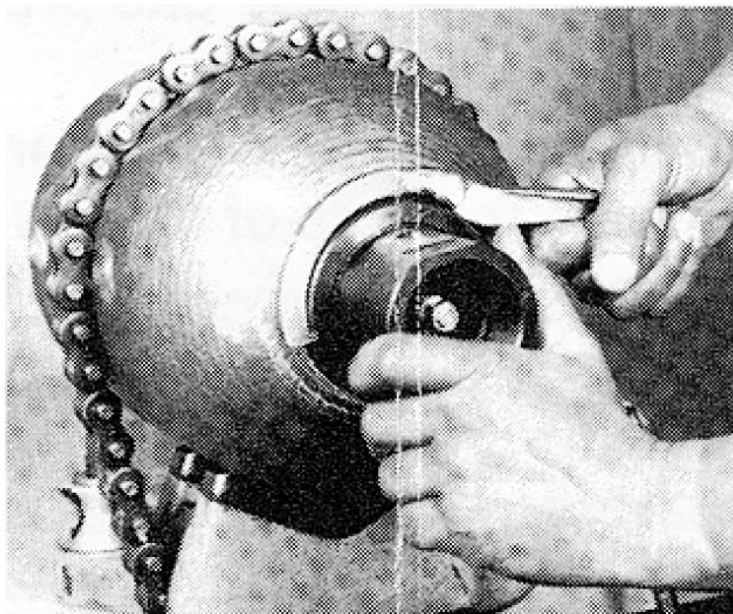

Photo K

- Install charging and gauging kit and pre-charge with **DRY NITROGEN GAS** as previously described.

