

**REED**



**A30HP**



# TRAILER MOUNTED PUMP MODEL A30HP HYDRAULIC COMPONENTS & SCHEMATIC

SCMTC

PAGE 01

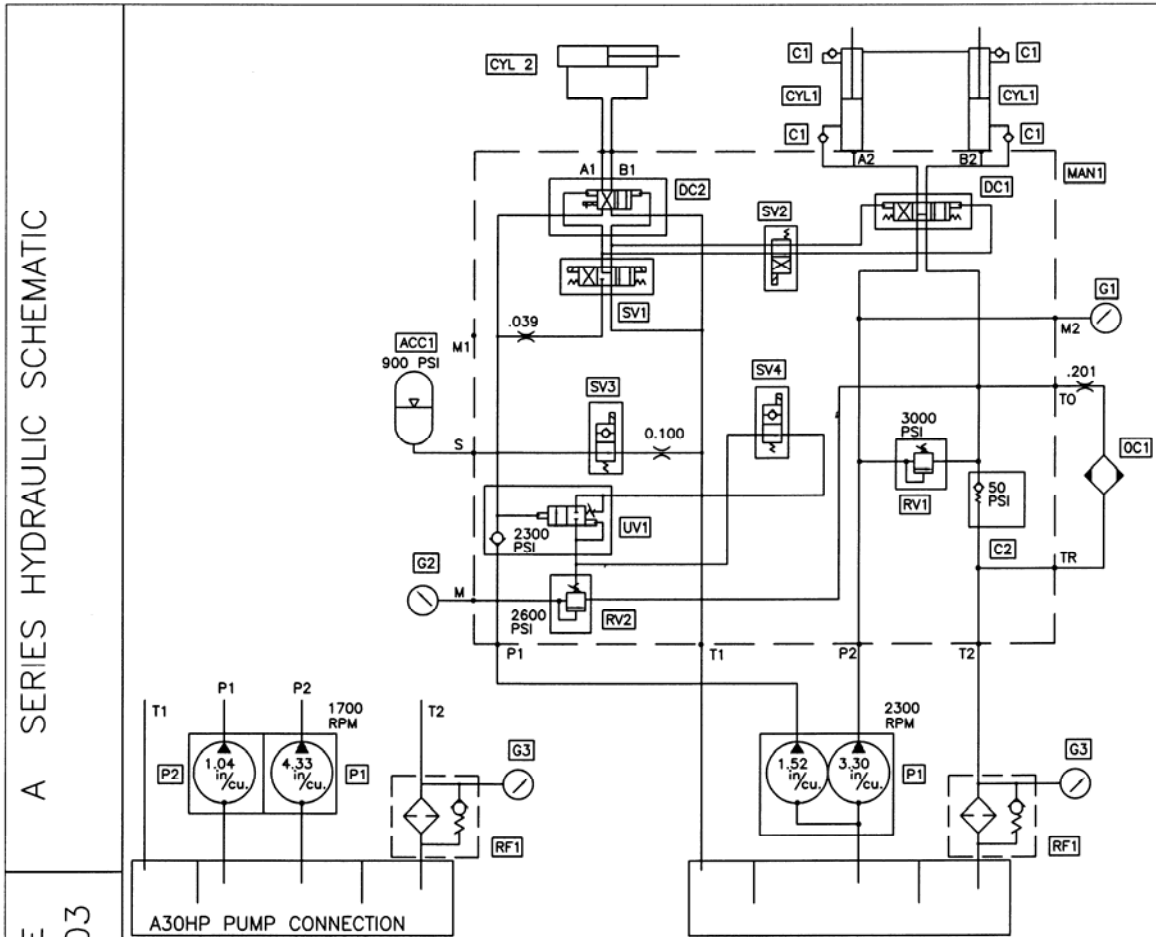

CODE	DESCRIPTION	PART NO.	QTY.
P1	Main Pump, Parts, Group 40		1
P2	Gear Pump, Parts, Group 40		1
CYL1	Hydraulic Drive Cylinder, Parts Group 60		
CYL2	Hydraulic Shift Cylinder, Parts Group 60	BW10125	1
MAN1	Manifold Drive & Swing Cylinder Circuit	BW10325	1
DC1	Directional Cartridge Valve, Main Cycling	BW10181	1
DC2	Directional Cartridge Valve, S Tube Shifting	BW10182	1
SV1	Solenoid Valve Pilot	85691	1
	Coil For SV1	85692	2
SV2	Solenoid Valve Pilot	BW10183	1
SV3/SV4	Solenoid Valve 2 Way	BW10185	2
RV1	Relief Valve Cartridge	BW10326	1
RV2	Relief Valve Cartridge	85703	1
UV1	Unloading Valve Cartridge	85704	1
ACC1	Accumulator	BW10184	1
C1	Check Valve	78961	4
C2	Check Valve	BW10327	1
G1	Pressure Gauge 6000 psi	74562	1
G2	Pressure Gauge 3000 psi	70366	1
G3	Pressure Gauge Return	85575	1
OC1	Oil Cooler		1
RF1	Return Filter	BW10027	1
	Return Filter Element	BW10106	1

A SERIES HYDRAULIC SCHEMATIC

DATE  
4/8/03

REV. C

PART NO.  
BW10041



REVISION:













# TRAILER MOUNTED PUMP MODEL A30HP TRAILER WIRING HARNESS

SCMTC

PAGE 04

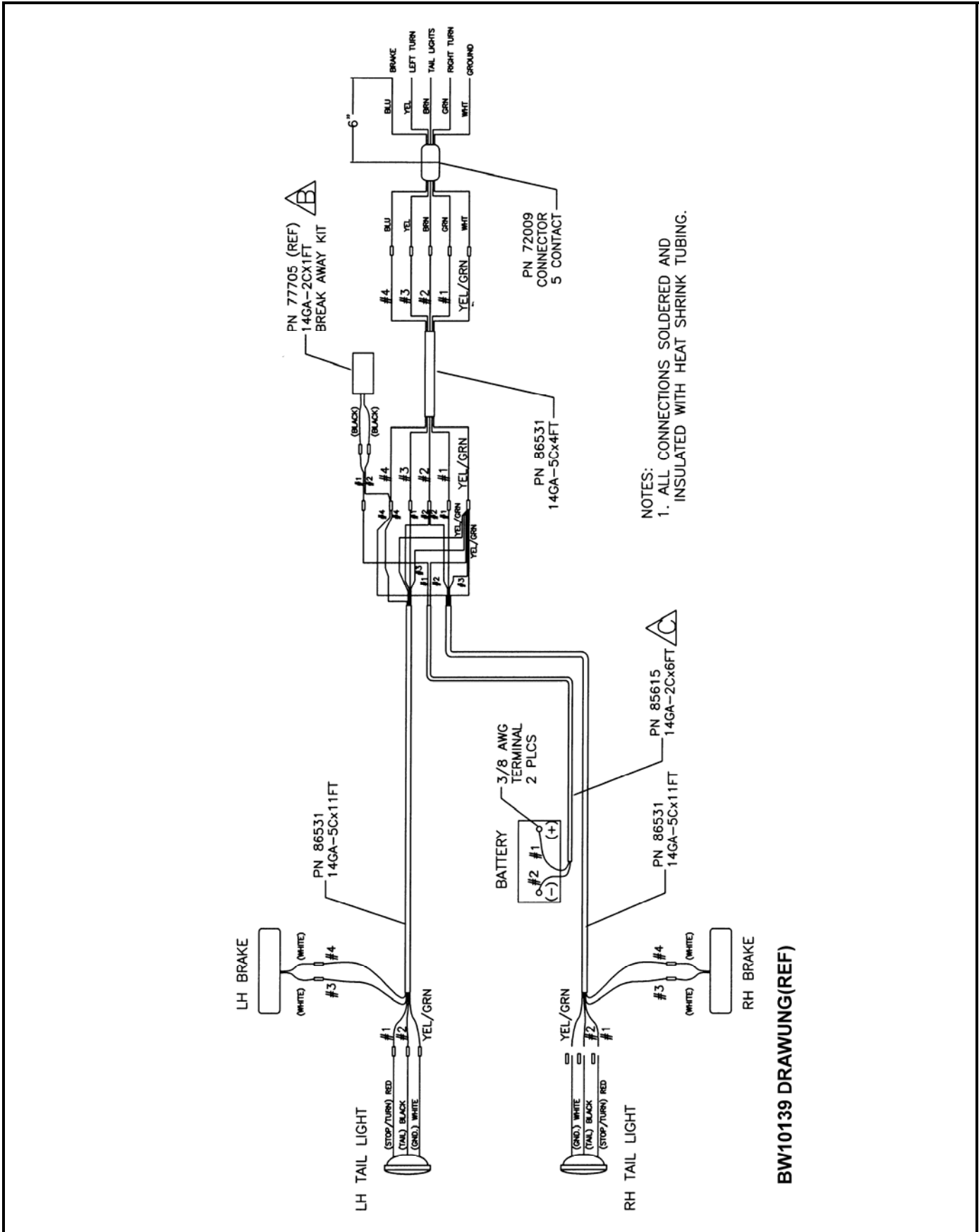

BW10139 DRAWING(REF)

REVISION: