

BOOM AND OUTRIGGER STABILITY TESTS 42 Meter 5 Sections RZ-Fold

Date:	Verify Machine Model:	REED Serial #:
Customer:	Truck VIN:	Truck Serial #:
Work Order #:	WZ Serial #:	

BOOM STABILITY TEST

Boom Manufacturer:	Boom Serial #:
Pedestal Manufacturer:	Pedestal Serial #:

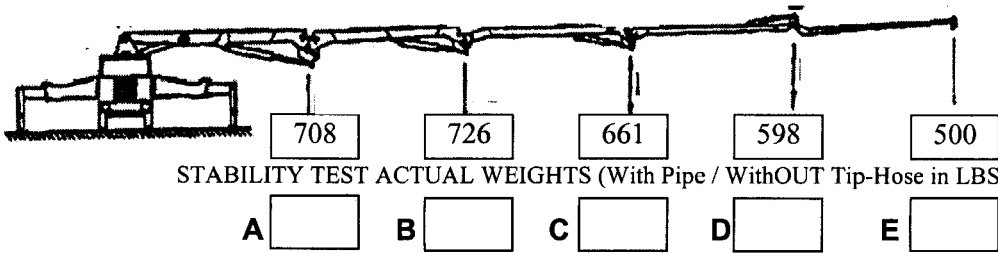

Checked: _____

TIME AND PRESSURE TESTS

	Element A	Element B	Element C	Element D	Element E	Rotation
Theoretical Times	104 sec	145 sec	140 sec	68 sec	55sec	212 sec
Time UP						
Time DOWN						
Head Side Pressure	310 bar	310 bar	310 bar	280 bar	280 bar	
Rod Side Pressure	340 bar	340 bar	340 bar	310 bar	310 bar	

Check for Section Minimum Drift and Holding Valve Leakage Under Load

Checked: _____

OUTRIGGER STABILITY TESTS

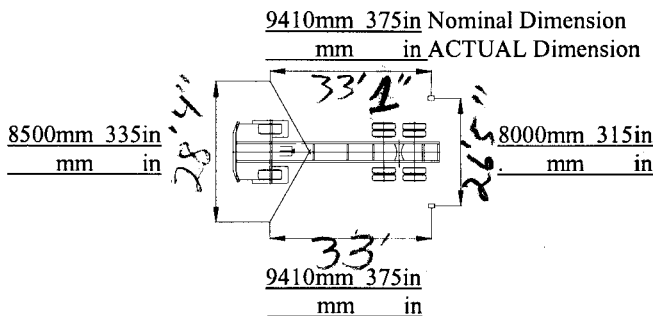

Outrigger Foot Lift		
FRONT	REAR	
in	in	RIGHT
in	in	LEFT

	Leakage Check		Leakage Check
Right Front Jack Cylinder		Left Front Jack Cylinder	
Right Front Telescope Out		Left Front Telescope Out	
Right Front Swing Out		Left Front Swing Out	
Right Rear Swing Out		Left Rear Swing Out	
Right Rear Jack Cylinder		Left Rear Jack Cylinder	

Checked:

TEST RESULTS:	
NAME: <u>DAVID RAMP</u>	DATE: <u>8/25/09</u>
SIGNATURE: <u>[Signature]</u>	DATE: _____

728
8491

JOB #	XT42-160 XT42-52		SN #
	customer:		
VL9094	BOOM MAKE UP PIPE LENGTHS		
	ARM		LENGTH
		A	90"
		B	42 3/4"
		B-C	43 3/4"
		C	29 1/4"
		C-D	21 3/4"
		D	16 1/2"
		E	20 3/8"
	PIPE TYPE (Ultra III or Normal?)		
	TIP HOSE SIZE		
	SPECIAL ELBOWS		PART #
	Turret	A sect	802576
	A sect	B sect	802766
	B sect	C sect	
	C sect	D sect	
	D sect	E sect	802766
	DECK MAKE UP PIPE LENGTHS		
	PIPE		LENGTH
		#1	
		#2	
		#3	
	SPECIAL ELBOWS		
	TURRET PIPE		
	DECK DELIVERY LINE COMPONENTS		PART #
	HOPPER ELBOW		
	ELBOW 6"		
	REDUCER		
	SPECIAL TURRET ELBOW		
	RADIO REMOTE SERIAL NUMBER		SERIAL #
	RADIO REMOTE		
	CABLE REMOTE		
	TRUCK		SERIAL #
	BOOM SIZE		SERIAL #
	XT42-160	XT42-52	4779
	BOOM SIZE---		SERIAL #
	PEDESTAL		
	A SECTION		CB20045223
	B SECTION		11
	C SECTION		11
	D SECTION		11
	E SECTION		11

MAST

890