

PREVENTATIVE MAINTENANCE

How good is any of the equipment you own? It is only as good as it is **MAINTAINED**. Even the finest equipment manufactured requires attention and care. The **MODEL XXT 42** is no different. A good well planned and carried out preventative maintenance program will enhance a properly operating unit as well as the safety of those operating and using the equipment.

It is very important to establish a good maintenance program. Costly repairs and loss of revenue can often be avoided by planning ahead, setting a regular schedule and exercising good preventative maintenance techniques.

The following section is offered as a guide and depicts a start for developing your own preventative maintenance program for the **MODEL XXT 42** concrete boom pump. It does not cover any part of the chassis. The program is depicted and broken into sections of **INSPECTION** and **LUBRICATION**.

NOTE

All points noted herein regarding the maintenance and checks are not intended to replace any local or regional regulations which may pertain to this type of equipment. It should also be noted that the list and schedule is not considered to be inclusive. Interval times may vary due to the climate and/or conditions associated with the location area in which the equipment will be used.

⚠ CAUTION

It is your responsibility to always insure that the applicable safety precautions are strictly observed when performing the inspections and maintenance checks. Make certain any components that are found to be defective are replaced or those in need of adjustments or repair are corrected before operating the machine.

SCHEDULED INSPECTION

The main purpose of accomplishing scheduled inspections is to identify and detect any potential malfunction before it can expand into a major problem. The list presented herein should be inspected and checked on a regular basis. In so doing it will help ensure a good, safe unit performance.

1. CHASSIS

- The overall condition of cab, inside and out, dents, missing or loose parts
- Engine oil level
- Fuel tank level
- Battery condition and cable connections
- Tire condition and inflation pressure
- Check for fuel, oil, transmission leaks
- Check chassis lighting, brake, signal, running

2. SUB-FRAME AND DECKING

- Inspect sub-frame, supporting structure for weld cracks, missing bolts
- Integrity of decking, steps, walkways
- Body side panels secure, condition
- Tool compartments and doors secure

3. UNDERCARRIAGE DRIVE COMPONENTS

- Power take-off mounting secure, oil level
- Visually check drive lines, no interference
- All hydraulic pumps in good condition, secure
- Check for loose, dangling electrical cables, wires, hoses, and tubing
- Look for hydraulic leaks

- All points properly lubed.

4. OUTRIGGER LEGS AND STABILIZER JACKS

- Check for damage, missing parts, rollers, pins, wear pads, bolts and nuts
- Inspect hydraulic cylinders, secure
- Foot pads installed
- Condition of hydraulic hoses, tubing. Securely installed properly clamped
- Control valves securely mounted
- Control levers move freely, protective boots in good condition
- Control toggle switches undamaged, emergency stop switch-push/pulls
- Level sight gauge in good condition
- All points properly lubed.

5. BOOM PEDESTAL AND TURRET

- Visually check pedestal and turret for structural damage, cracked welds
- Insure all rotation gear mounting bolts are secure
- Drive pinion and gear teeth in good condition
- Reduction unit securely mounted
- Rotation limit stops in good condition
- Delivery line piping, swivels, clamps secure
- Hydraulic hoses, tubing secure, properly clamped no leaks
- All oil levels full and points properly lubed

**6. BOOM ASSEMBLY-ALL SECTIONS
(REPEAT FOR EACH SECTION WHERE APPLICABLE)**

- Visually check for structural damage, cracked welds
- Ensure all bushings, pins and retainers are in place
- Hydraulic cylinder in good condition, securely mounted
- Hydraulic hoses, tubing secure, properly clamped no leaks
- Delivery line not damaged, no dents, secured properly to boom
- All clamps secure, retaining pin in place
- All delivery line swivels secure
- All points properly lubed

7. BOOM END DELIVERY HOSE

- Check for damage, condition, free of cuts internal and external
- Mounted securely to boom, support brackets in tact
- Locking levers, lever springs in place, good condition
- Hose clamps secure, retaining chain in good condition, shackles and pins tight

8. BOOM CONTROL

- Hydraulic control valve bank securely mounted
- Each control lever moves freely, returns when released
- Protective rubber boots in good condition
- Control identification decal in good condition
- Hydraulic tubing, hoses and electrical wiring secure and clamped
- No hydraulic leaks

**9. CONCRETE PUMP
(PUMP CELL)**

- Visually check for structural damage, cracked welds of pump cell, secured to sub-frame
- Hydraulic drive cylinders in good condition, secure no leakage
- Material cylinder secure
- Water box structurally sound, clean, cover in place, drain functional
- S-tube shift mechanism structurally sound, all pins and retainers in place
- Hydraulic shift cylinders in good condition
- Bearing housing, seals etc. in good condition
- Hydraulic hoses secure no leaks
- All lube points greased

10. HOPPER ASSEMBLY

- Visually check for structural damage, dents, cracked welds
- S-tube secure, in good condition
- Check condition of spectacle plate, wear ring, seals
- Check connection of S-tube to outlet seals, bearing
- Hopper grating is structurally sound, opens and closes
- Vibrator securely mounted, wiring connections secure
- Hopper drain is functional
- Transfer delivery line undamaged, secured all clamps tight with pin retainers
- Outlet elbow secure, clamp tight

11. AGITATOR

- Visually check agitator worms for damage, cracked welds
- Drive motor secure, bearings, seals housing in good condition
- Control valve securely mounted, lever moves freely
- Hydraulic hoses and tubing secure, clamped

12. LUBE SYSTEM

- Lube pump securely mounted, all parts reservoir gaskets, lid in place
- Lube line connections tight, clamped
- Ample grease in reservoir

**13. PUMP CONTROL PANEL
(STATIONARY)**

- All toggles in good condition, stay in position or momentary return to center
- Instruments and gauges in good condition, lights operate
- Control identification in good condition

**14. REMOTE CONTROL PANEL
(CABLED)**

- All toggles in good condition, stay in position or momentary return to center
- Boom control levers move freely, return to center, protective rubber boots in good condition
- Umbilical cord in good condition, not damaged or cut and securely connected

15. HYDRAULIC SYSTEM

- Boom tank securely mounted, filler cap in place, level sight gauge in good condition
- Pump hydraulic tank securely mounted, filler cap in place level sight gauge in good condition
- Check hydraulic filter condition gauges, not damaged
- Hydraulic oil cooler securely mounted, fan motor in good condition
- All hydraulic fluid levels to proper level
- All hoses and tubing's secure, no leaks

16. WATER SYSTEM

- Water tank securely mounted, filler cap in place, level sight gauge in good condition
- Water pump securely mounted, all connections made
- Control valve at hopper secure, lever functions easily all connections tight

**17. REMOTE CONTROL PANEL
(RADIO)**

- All toggles in good condition, stay in position or momentary return to center
- Boom control levers move freely, return to center, protective boots in good condition
- Check receiver and connections, battery charger and batteries in good condition

LUBRICATION

The **REED MODEL XXT 42** is equipped with several critical areas that require lubrication. These areas involve various points on the outriggers, pedestal, turret and boom structure, S-tube shifting mechanism, S-tube swing components, shift and outlet, and the agitator components.

To insure economical service and long life of the components, the unit has been equipped with an automatic central distribution system for the S-tube shifting, swing components and agitator. This system consists of a six (6) port distribution block located at the hopper. The block is fed by the auto lube pump and reservoir unit, then distributed to the areas by plastic tubing. The interval of lubrication can be adjusted to meet the conditions.

The lube points on the boom structure and other areas have individual grease fittings for direct manual lubrication.

▲ WARNING

Rapid wear and probable component breakdown will result if the unit is operated with inadequate lubrication. Follow the recommended interval and if need be increase the interval when above normal usage takes place.

LUBRICANT AND INTERVAL

The recommended lubricant is generally the best choice, however, should this lubricant be unavailable in your area, consult your local supplier for an equivalent.

On the same basis, recommended lubrication intervals are based on normal use in normal environmental conditions. User is **CAUTIONED** to adjust the lubrication interval accordingly to meet each individual condition and usage. Look for tell-tell signs while machine is in operation. If the S-tube swing point components become extremely hot or lubricant becomes a liquid and oozes out around the bearing or seal, the area should be relubricated.

Make it a practice to wipe clean the grease fitting before and after lubricating. Also external non-bearing surfaces are to be cleaned of any extended grease with a clean cloth to prevent damaging dust and abrasive accumulation on lubricated wet surface.

If the **MODEL XXT 42** has been stored or exposed to environmental conditions of extreme low humidity, high dust level, elevated temperatures or heavy rainfall, lubrication of components may be required more frequently than under normal conditions.

LUBRICATION POINTS**A. BOOM AND OUTRIGGER AREA**

There are several points on the boom structure that requires lubrication. These points are noted in the diagrams below and involve all the articulated joints on the boom, the swivels and rotating joints of the concrete delivery piping and the pivot points of the swing out outriggers.

⚠ CAUTION

Before making the connection of the lube pump to grease fitting be sure to WIPE CLEAN the fitting to prevent contaminants from entering the lube point. Wipe off any excess lubricant after greasing fitting.

Recommended lubricant: **GENERAL PURPOSE GREASE SHELL ALVANIA EPLFH2
OR EQUAL**

Recommended interval: **EVERY 60 HOURS OF OPERATION UNDER NORMAL
USAGE. MORE FREQUENT AS REQUIRED**

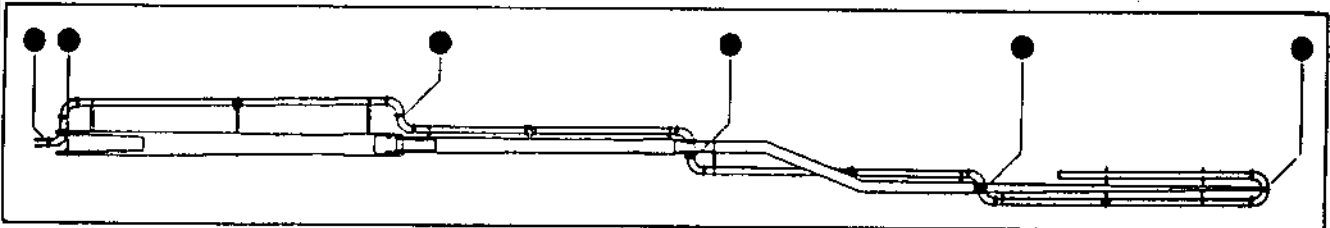
**DELIVERY LINE ROTATING LUBE POINT**

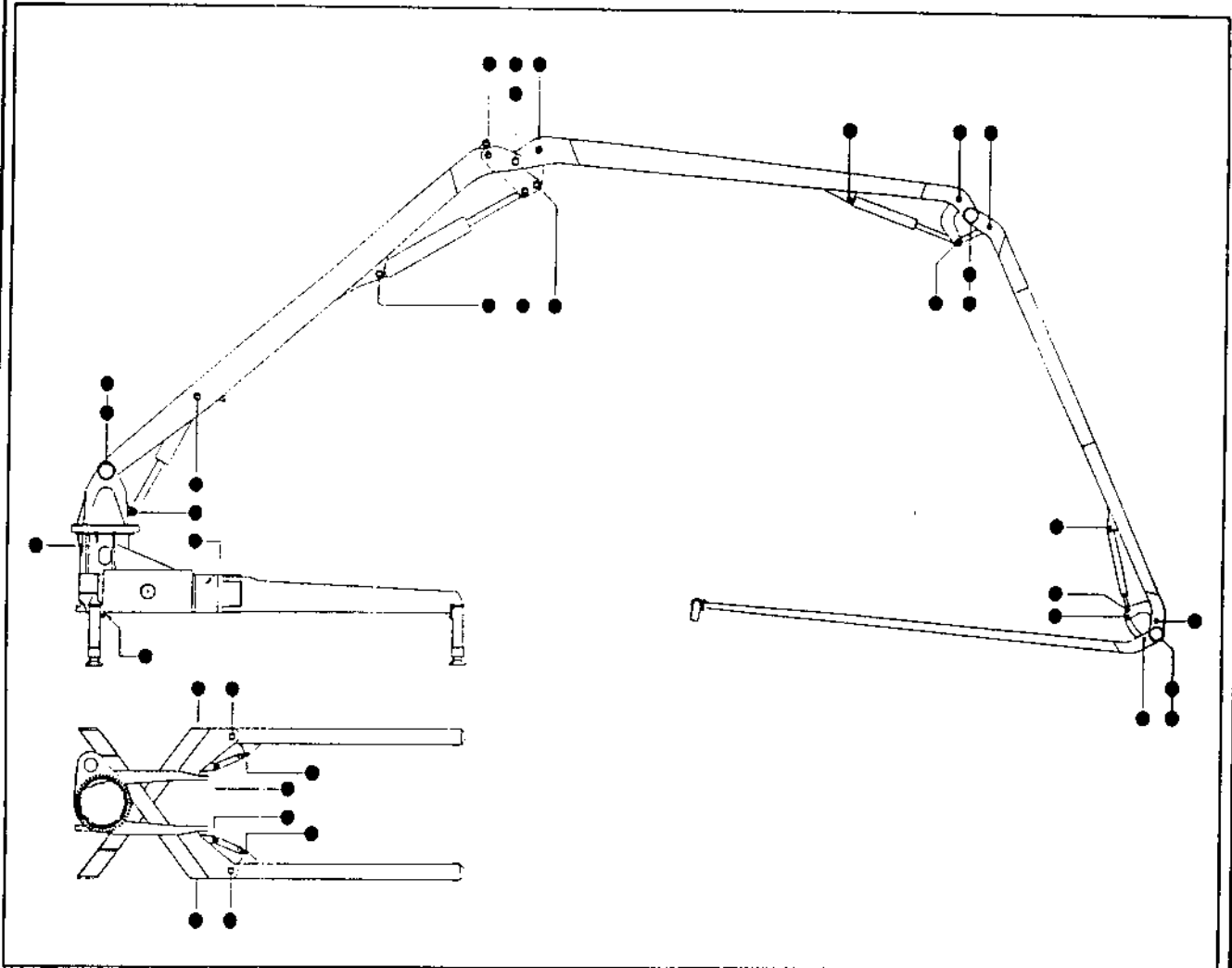
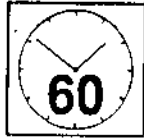

B. CONCRETE PUMP AREA

This area's critical lube points except for the material cylinders are connected to the central lubrication distribution block and fed by the automatic lube pump. The main lube pump and reservoir is located at rear of unit near hopper. This system will automatically feed the central distribution block at the preset interval. However the reservoir must be checked and lubricant replenished if necessary on a daily basis. For areas not connected to the auto lube system, use a manual lube pump and pump a sufficient number of strokes to ensure thorough lubrication of each point. **VISUALLY CHECK EACH POINT.** Wipe off any excess lubricant. The material cylinders are equipped with a grease fitting at the flush box end of tube.

Recommended lubricant: **GENERAL PURPOSE GREASE SHELL ALVANIA EPLFH2
OR EQUAL**

Recommended interval: **DAILY BEFORE START-UP AND AS REQUIRED DURING
OPERATION**

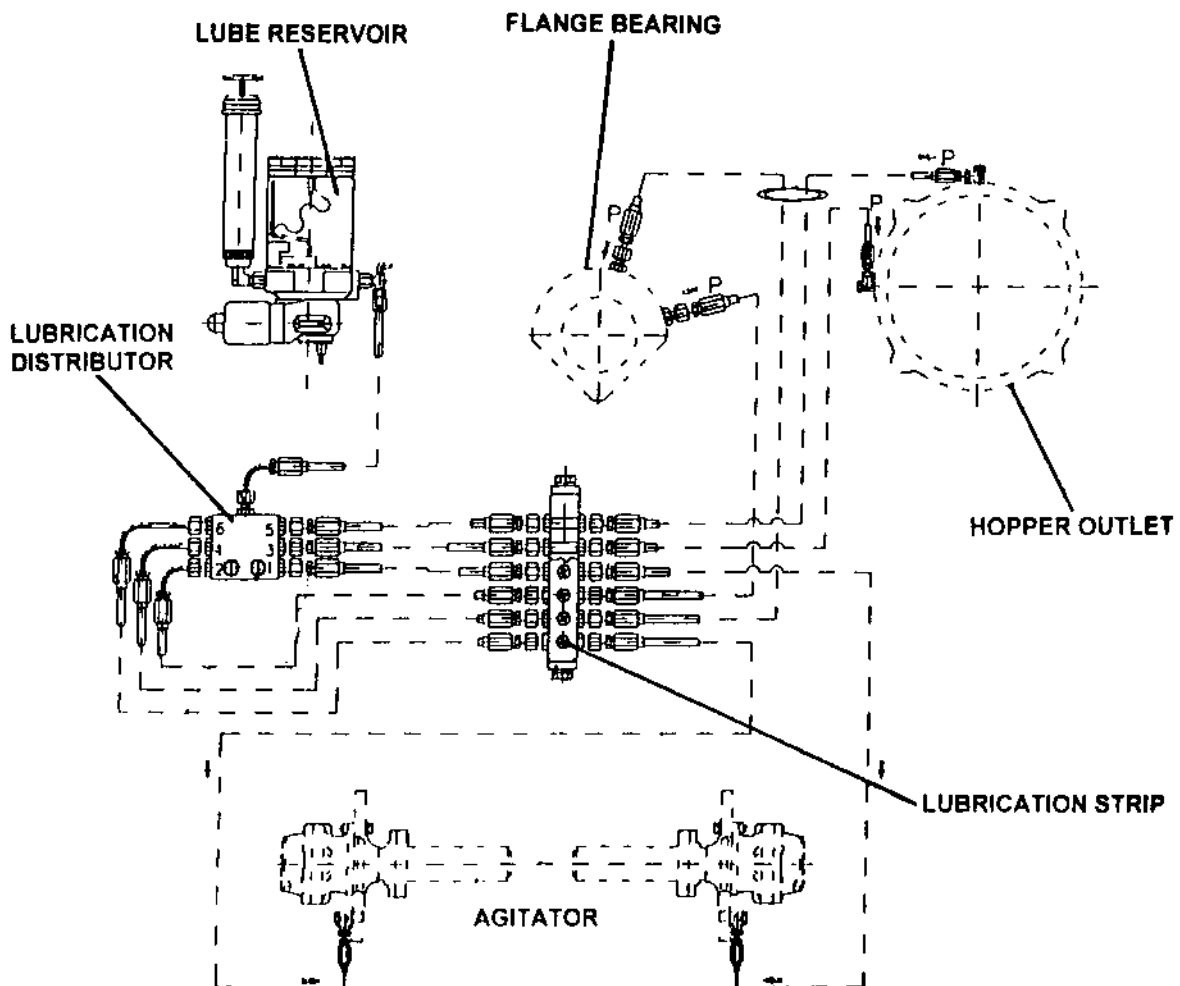

C. BOOM ROTATION UNIT

This lubrication attention area involves the turret rotation gear reduction unit, rotation bearing and pinion.

1. ROTATION BEARING

Greasing serves to reduce the ball friction and maintains the bearing seal as well as offering protection against the entry of contaminants. Inject the grease until it is made to exit from the gasket.

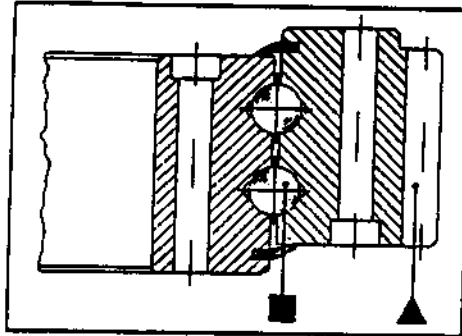

For lubrication of gear teeth on bearing and pinion smear or brush recommended oil on all areas of teeth.

Bearing lubricant: **GENERAL PURPOSE GREASE, SHELL ALVANIA ELPFH2 OR EQUAL**

Gear teeth lubricant: **SHELL MALLEUS FLUID "C" OR EQUAL**

Recommended interval: **EVERY 100 HOURS OF OPERATION**

2. GEAR REDUCTION UNIT

This unit is located on the outside of the turret pedestal and requires attention on a daily basis. An oil level plug is located on side of reduction unit. The breather and fill extends from reduction unit opposite oil level plug and is readily accessible. Remove the cap to add oil if necessary.

Lubricant: **SHELL OMALA OIL 150**

Interval: **CHECK DAILY FILL AS REQUIRED (TOTAL CAPACITY OF OIL = 5.6 LITERS)**

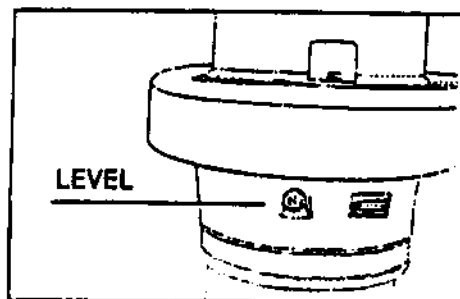

D. POWER TAKE-OFF (P.T.O.)

The power take-off unit contains two (2) areas requiring lubrication attention. One area is the main gear box and the other is the pump shaft cavity.

The oil level plug for the main section is located on side of the casing. Remove plug to check level. When required add oil through breather fill fitting.

The oil level plug for the pump shaft cavity is located on side of flange ring. Remove plug to check level. When required add oil through cavity breather fill unit.

Recommended lubricant: **SHELL 80 WT. GEAR OIL OR EQUAL**

Recommended interval: **CHECK LEVEL EVERY 100 HOURS OF OPERATION**

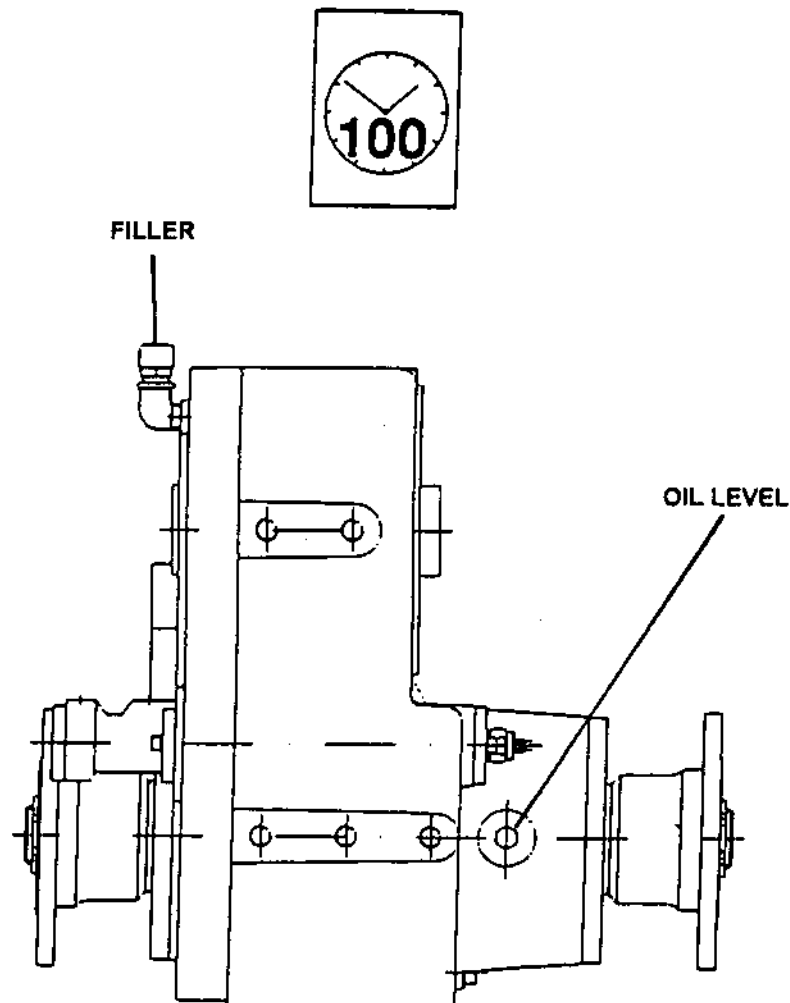

HYDRAULIC SYSTEM MAINTENANCE

The **REED MODEL XXT 42** concrete boom pump is equipped with two (2) separate complete hydraulic systems. One system is used to meet the hydraulic requirements for operation of the boom structure and the other hydraulic system is used for the operation of the concrete pump functions. Both systems are critical to their own particular operation and it is for this reason that it is important they receive extra care and good maintenance.

▲ CAUTION

CONTAMINATION is the downfall of most hydraulic systems and a major contributor leading to system malfunctions. Extreme care must be exercised to prevent dirt from entering the system. Make it a habit to ALWAYS cap or plug open ports and hydraulic lines.

HYDRAULIC TANK

- **BOOM HYDRAULICS**

The hydraulic tank having a capacity of 106 gals (400 L) is located inside the boom pedestal and is an integral part of the machine superstructure. The tank is equipped with a filler breather cap located outside the pedestal and facing chassis cab. A 25 micron return filter assembly is located under the main pump hydraulic tank near the oil cooler. A high pressure filter is located on the curb side of unit behind the tool box. A sight gauge is located on outside of the tank facing cab of unit and used to visually determine the fluid level inside tank.

- **CONCRETE PUMP HYDRAULICS**

This hydraulic tank has a capacity of 118 gals (450 L) and is located on the forward end of the boom pedestal. The tank is equipped with a filler breather cap located on top of the tank and a access cover on the top side of tank. A sight gauge is installed on the outside of the tank and is used to determine the fluid level inside the tank.

Two (2) suction filters are located and installed on the forward face of the main tank. In addition, a charge filter has been installed on each of the two main pumps.

SYSTEM MAINTENANCE ITEMS

The following are specific items for care and maintenance of the hydraulic system.

- **FLUID LEVEL-** It is **IMPORTANT** that the fluid level be checked **DAILY**. Maintain fluid to proper level at all times.
- **TANK BREATHER-** Clean every 50 hours of operation. Remove from tank and clean with solvent and air blow dry.
- **SUCTION FILTERS-** For the concrete pump and boom these are 10 micron filters with disposable elements. Change element when filter condition gauges indicates to do so.

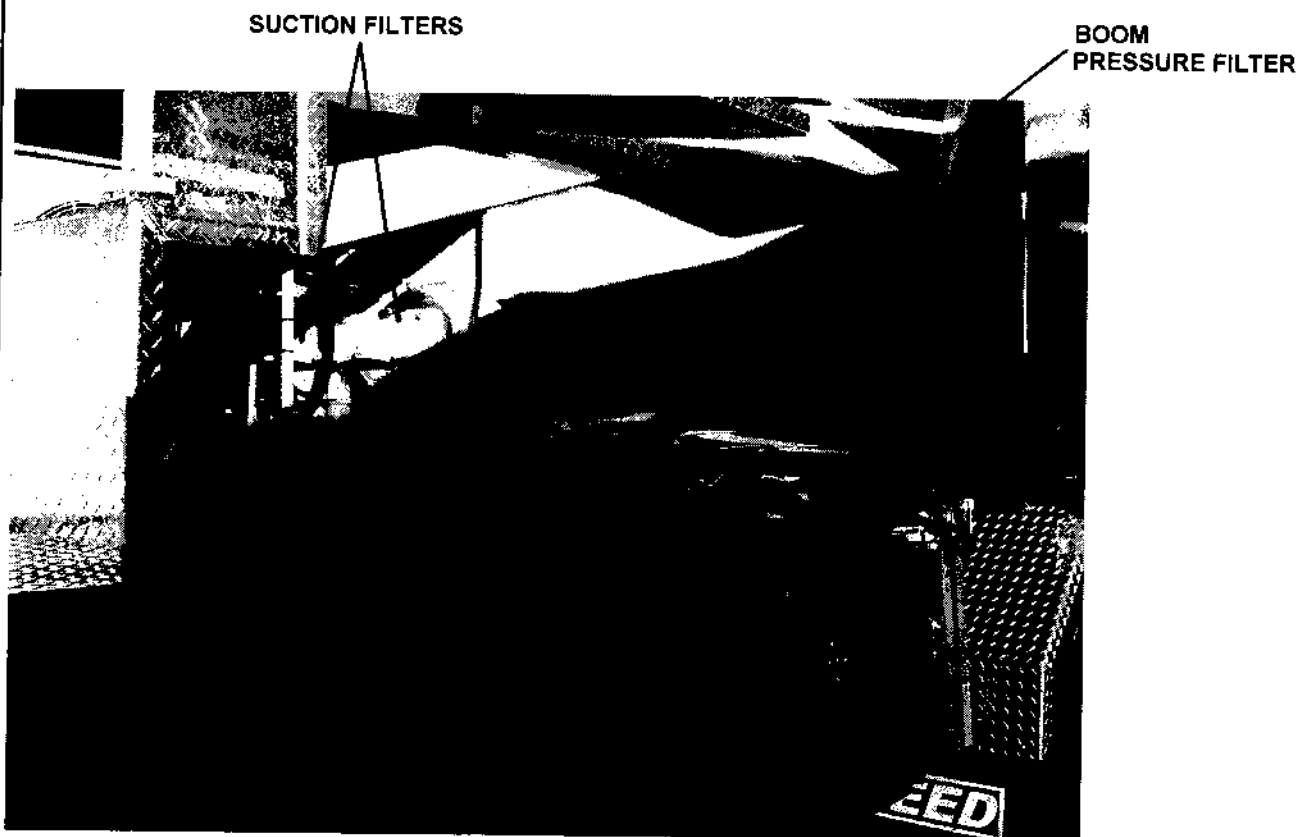

- **BOOM PRESSURE FILTER-** This is a 10 micron filter and is equipped with condition indicator.
- **CHARGE FILTERS - (Concrete Pump)** These filters are 10 micron filters with disposable element. Change every 200 hours .

- **HYDRAULIC TANK-** Change oil in tank every 1500 hours of operation or yearly whichever comes first.

NOTE

After fluid loss for any reason, filter replacement, component removal etc. sufficient fluid must be added to properly maintain required level in tank.

HYDRAULIC FLUID

The **MODEL XXT 42** utilizes in its hydraulic system a fluid manufactured by the SHELL OIL CO. and is designated as TELLUS #46. It is to be used in ambient temperatures of 39-90° F (4-32° C). The normal fluid temperature will range from 100-167° F (38-75° C).

For ambient temperatures of 90° F (32° C) and above use fluid designated as a ISO rating of 68. Use ISO 32 for ambient temperatures of 32° F (4° C) and below.

▲ WARNING

USE ONLY SHELL TELLUS 46 or equal hydraulic fluid and NEVER MIX with other type fluids. Always use a CLEAN fluid. Using impure or other type of fluids not specified will contaminate the hydraulic system and can lead to eventual system malfunction or damage and possibly deteriorate the hydraulic seals.

ADDING HYDRAULIC FLUID

As previously indicated, a hydraulic systems worst enemy is **CONTAMINATION**. Exercise extreme care when adding fluid to the hydraulic tank.

- To prevent any dirt or water from entering the hydraulic tank, thoroughly clean area around filler opening.
- Use fresh clean hydraulic fluid. If a hand pump is used to transfer fluid, check that pump filter is clean. If pouring of fluid, pour it through a fine wire mesh screen, 200 mesh or finer.

- Replace filler cap immediately after filling tank to proper level.

▲ WARNING

Do not use a cloth for straining fluid as lint is harmful to the hydraulic system.

FILTER SERVICING

The purpose of installing hydraulic filters in the system is to provide a means of continuous hydraulic fluid filtration in an effort to prevent recirculation of abrasive solids which will cause rapid wear of component breakdown.

The filter assemblies on the pump and boom circuits are equipped with condition indicators. These need to be checked periodically and the element changed when so indicated.

The filter for the boom hydraulics is a high pressure filter. It is also equipped with a condition indicator.

To service/change the filter elements the following is offered:

SUCTION FILTERS

- Shut off machine and allow a few moments for the accumulator system to depressurize
- Place a drain pan underneath the filter housing to catch any fluid drainage
- Wipe clean any dirt and grime from around filter housing
- Loosen the hex nuts on the filter end cap
- Turn the end cap counterclockwise (left) one-quarter turn to unlock assembly.
- Pull out complete cartridge.

NOTE

A check valve is installed at the filter intake. This shuts automatically preventing oil from flowing out of the tank when cartridge is removed.

- Remove hex nut at bottom of filter element. Turn filter element to left and pull it off of lid and slide off magnetic rod. Discard element.
- Clean magnetic rod with a cloth wiping it several times along the rod.
- Install new filter element on rod and end cap.
- Check o-ring for damage, replace if necessary.

CHARGE FILTERS

These are located on each of the main hydraulic pumps and are serviced as follows:

- Shut-off machine and allow a few moments for the accumulator system to depressurize.
- Place a drain pan underneath the filter housing to catch any fluid drainage.
- Wipe clean any dust and grime from around filter housing.
- Using a wrench or socket on cannister nut loosen and unscrew filter cannister.
- Remove from filter head and remove filter element and discard.
- Clean inside of cannister with solvent and air blow dry.
- Check condition of o-ring, replace if necessary. Insert new element in cannister and install cannister onto filter head.
- Start machine and check for leaks.

BOOM FILTER

This is high pressure filter used in the boom hydraulic circuit and located on curb side of the unit behind the tool box. It is serviced in basically the same manner as noted above for charge filters.

▲ CAUTION

DO NOT ATTEMPT TO WASH OUT ANY OF THE FILTER ELEMENTS. These are disposable types and more harm can be done than its worth.

CLEANING THE HYDRAULIC TANK

The hydraulic tanks should be drained and cleaned after 1500 hours of operation or yearly whichever comes first. This will assist in keeping the systems clean and in proper condition. To accomplish this the following is offered and generally will apply to both hydraulic tanks.

- Shut off machine. On pump circuit allow accumulator system to depressurize

Place a suitable size container under the hydraulic tank sump drain. **NOTE:** The boom tank has a capacity of 106 gals (400 L) and the concrete pump hydraulic tank has a capacity of 118 gals (450 L). Make sure your drain container is large enough. Open drain valve.

- Remove the access cover(s) on the hydraulic tank being careful not to damage the gasket
- On the pump hydraulic tank remove the two (2) suction filter elements.

After tank has drained, flush the inside of the hydraulic tank with clean solvent and wipe clean with lint free cloths. **DO NOT USE PAPER TOWELS.** Remove any particles from tank bottom and sump

- Close the tank drain valve. Reinstall the access covers with gasket
- Clean the filler breather with solvent and air blow dry
- Change the hydraulic system filter elements both pressure, suction and charge
- Refill the hydraulic tank with new **CLEAN** hydraulic fluid, **SHELL TELLUS 46**
- Start machine and check for leaks



XXT42 TRUCK - MOUNTED CONCRETE BOOM PUMP

MAINT

PAGE 19

HYDRAULIC SYSTEM FAMILIARIZATION

The **REED MODEL XXT 42** Concrete Boom Pump is dependent on hydraulics for operation of its many functions. Two (2) separate independent hydraulic systems are employed on the unit. One system is used for operation of the boom and outriggers and the other system is used for operation of the concrete pump and related components.

For the purpose of making it easier to understand the hydraulic systems, we have chosen to describe and familiarize you with each system separately.

BOOM HYDRAULIC SYSTEM

SPECIFICS - PRESSURES

- Maximum System Pressure & Relief = 4500 PSI (320 Bar)
- Boom Section "A" - Relief = 4000 PSI (280 Bar)
 - Cylinder Relief - Extend, Retract = 3500 PSI (250 Bar)
- Boom Section "B" - Relief = 4000 PSI (280 Bar)
 - Cylinder Relief - Extend, Retract = 3500 PSI (250 Bar)
- Boom Section "C" - Relief = 4500 PSI (320 Bar)
 - Cylinder Relief - Extend = 3500 PSI (250 Bar)
 - Cylinder Retract = 4500 PSI (320 Bar)
- Boom Section "D" - Relief = 4000 PSI (280 Bar)
 - Cylinder Relief - Extended = 2850 PSI (200 Bar)
 - Cylinder Relief - Retract = 4500 PSI (320 Bar)
- Rotation Relief Pressure = 2000 PSI (140 Bar)
- Outrigger Circuit Relief = 2850 PSI (200 Bar)

BOOM HYDRAULIC CIRCUIT DESCRIPTION (Refer to Hydraulic Schematic)

With chassis engine started and having engaged PTO the boom hydraulic pump becomes operational. The pump is of the piston type design of constant displacement and produces the preset flow and pressure when the engine speed is at the maximum preset RPM. When no control is actuated, the hydraulic fluid passes through the master section of the distribution block and is returned to the hydraulic tank.

The distribution block is located on the curb side up on the deck and just to the rear of the swing outrigger pivot. It is a control valve bank which consists of six (6) manual operated directional control valves of a spring return to neutral type. In addition to manually controlling the valves, a means is provided to enable the valves to be controlled remotely using an electric power source to actuate the valve spool.

OUTRIGGER HYDRAULIC CIRCUIT

Control of the swing out beams, telescopic legs and the vertical jack operation is accomplished by the use of two (2) groups of control valves located one each side of the chassis. The **RIGHT SIDE** controls the right side swing out beam telescopic, leg and jacks. The **LEFT SIDE** controls the left side swing out beam telescopic, leg and jacks. These control valve groups consist of a bank of 4 directional control valves. The valves are manually actuated with lever movement in either direction for the specific function and will return to center when released. They are used to extend or retract the outrigger cylinders. These valves are inoperable until the **MASTER** outrigger valve has been actuated.

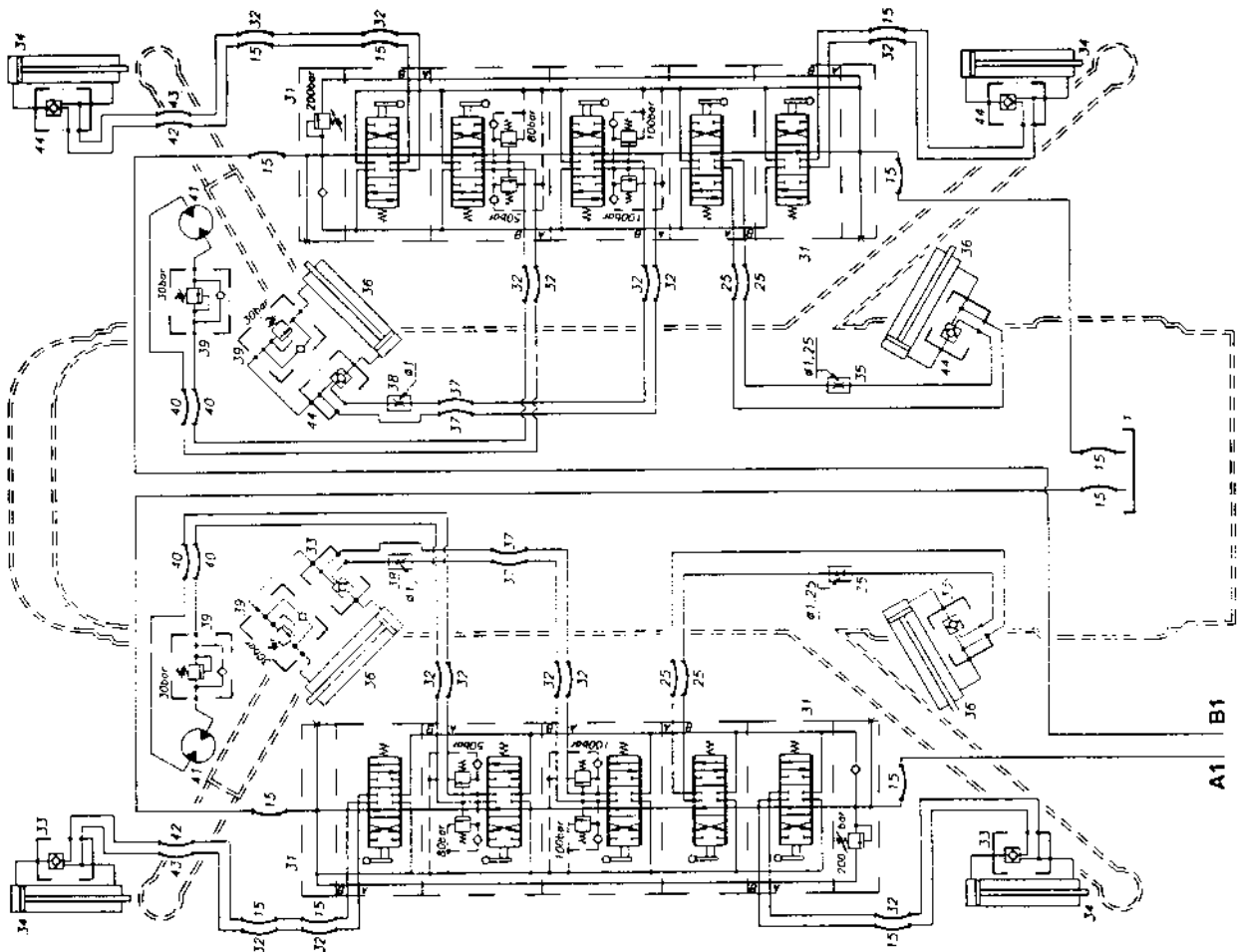

The **MASTER** outrigger valve is located and is part of the boom hydraulic circuit distribution block located on the deck. It is the first valve section from the left and is a manual lever controlled directional valve. The valve is used to direct the flow of oil to the outrigger circuit for the extension or retraction operation. Because of the need to control several functions, a means has been provided to electrically actuate the valve remotely.

Operation of the outrigger controls from either side, right or left, first requires energizing the circuit. This is accomplished by the **OUTRIGGER** switch. This is a toggle switch control located on the main control panel with the purpose of energizing or de-energizing the outrigger electrical circuit. It also acts as a safety precaution against accidental actuation of the outrigger circuit when the boom is elevated.

Once the **OUTRIGGER SWITCH** is **ON** the **INTERLOCK** switch is used to electrically energize the coil of the **MASTER** outrigger valve. This is a momentary push button switch which must be held in **ON** position or it will return to **OFF** position. With **INTERLOCK** switch depressed and held by moving the lever of the control valve, hydraulic fluid is permitted to flow in the appropriate direction to the specific cylinder of the outrigger circuit.

The swing out – in operation of each rear beam is controlled by its own control valve and the circuit description for each is identical. The swing out cylinder is equipped with a holding valve installed on the barrel or extension side. As soon as the flow ceases, control unactuated, the holding valve closes thereby locking the fluid in the cylinder. When the control is actuated to retract the cylinder, fluid from the barrel side must be exhausted and allowed to return to tank. This is accomplished by pilot pressure obtained from the fluid going to the rod side of the cylinder. In an effort to obtain a smooth swing out-in motion in lieu of erratic operation, a throttle valve is installed in the circuit. This valve regulates the hydraulic flow going to or from the cylinder. These valves are non adjustable.

The front legs are of the swing out type and each contains a telescopic section. The swing out cylinders, like the rear are equipped with a holding valve on the barrel side of the cylinder. A relief is incorporated in the control valve and set at 1500 PSI (100 Bar). This is to protect against excessive pressure. The telescopic section is extended and retracted by use of the reversible hydraulic motor in a chain and sprocket arrangement. This control valve is also equipped with a relief to prevent over extension and continuing applying pressure to a point of breakage of the chain.

The vertical jacks operate from their individual control and the cylinders are equipped with holding valves on the barrel side.

BOOM CONTROL HYDRAULIC CIRCUIT

This circuit involves the operation of the four (4) boom sections and turret rotation. Basically with the exception of the pressure relief setting, the circuit is identical for all four (4) booms. Because of this, the boom circuit description will be in general terms.

Each boom section is controlled by the appropriate manual directional valve section located on the distributor block. When a control lever is actuated, it in turn shifts the valve spool of that particular function and directs the hydraulic fluid to the hydraulic cylinder for extension or retraction. Each cylinder is equipped with two holding or lock valves.

One is used on the barrel side of the cylinder and the other is used on the rod side. The purpose of these valves is to retain the fluid in the cylinder when not actuated.

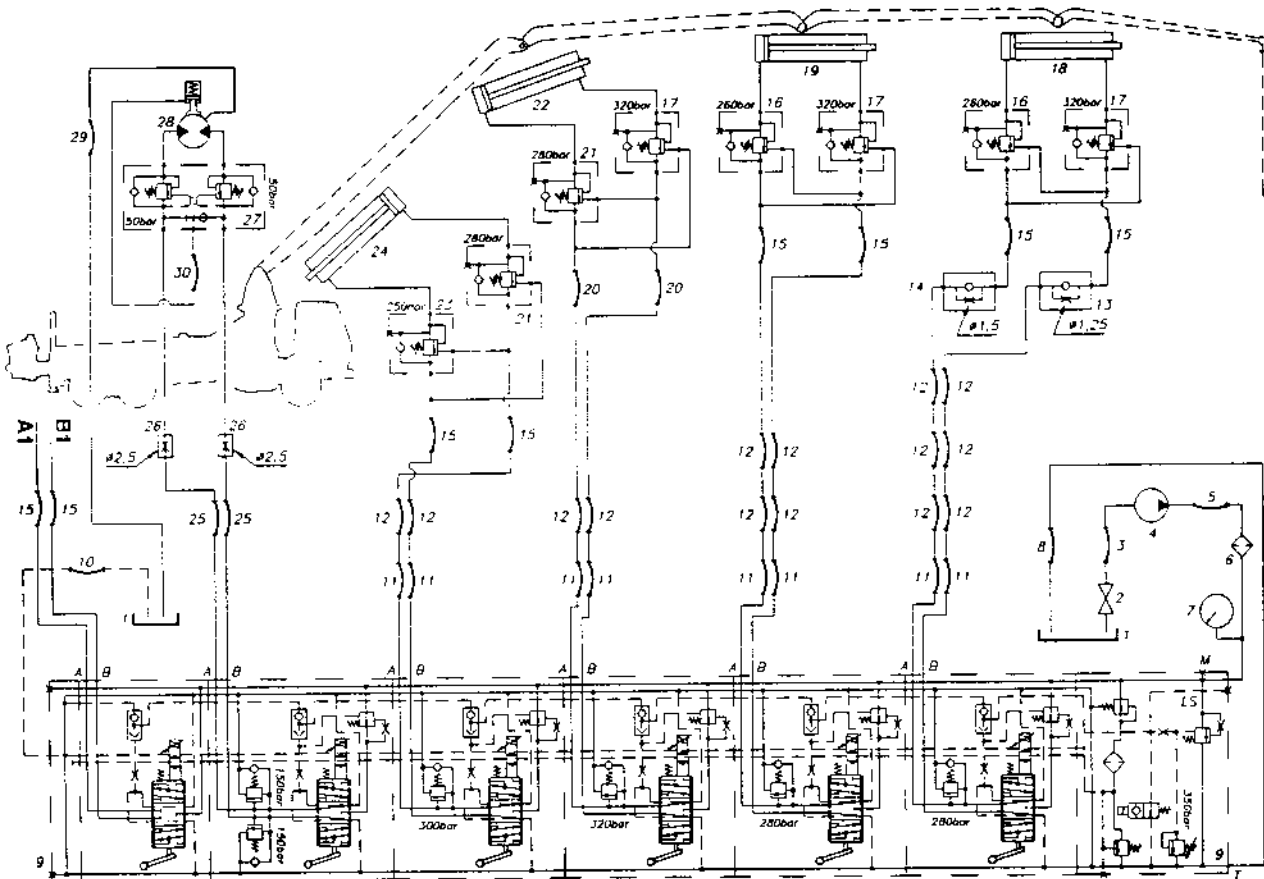

In operation, should the control for Boom "A" be actuated to the **EXTEND** position, hydraulic fluid will be directed to the barrel side of Boom "A" cylinder. It will pass freely through the barrel side holding valve unseating the ball check. However, a holding valve is also installed on the rod side of the cylinder to retain the fluid in that cavity. Thus, if the cylinder is to be extended, then fluid must be exhausted from the rod side. To accomplish this, pilot pressure is used from the extension circuit and applied to the ball check of the rod side holding valve, unseating the ball and allowing the fluid to be exhausted to tank. As long as pressure is applied to extension, both valves will be open.

In addition, this same valve is used as a relief valve to protect the system against excessive pressure. Any excessive pressure created would be on the cylinder itself and would no doubt be caused by an overload of the booms.

In the Boom A, B, and C hydraulic circuit, a flow control check valve is installed on the piston or barrel side of cylinder. The purpose of this valve is to slow down the flow of the fluid being exhausted from the barrel to prevent erratic motion of the boom when the rod side is pressured. In the Boom "D" circuit, a flow control check valve is installed on both sides of the cylinder. These valves are adjustable and have been set at the factory and should only be adjusted by qualified persons in a maintenance operation.

TURRET ROTATION CIRCUIT

The rotation circuit of the turret or boom structure feeds off the same distribution block as the boom and is controlled by the directional control valve located second from the left on the block. A hydraulic motor is used to drive the rotation mechanism. When the directional valve is actuated, fluid is directed to the side of the motor which corresponds to the appropriate movement of the valve lever.

Like the boom circuit, the rotation circuit is also equipped with a holding valve. However, this valve is somewhat different in that it is a double pilot operated holding valve and contains a shuttle valve feature. The lock valve works or is opened and closed by pilot pressure in same manner as that on the boom circuit.

The purpose of the shuttle valve is to control the hydraulic rotation brake. The brake is spring applied and hydraulically released. When the rotation control is actuated to a specific direction, this same flow going to the rotation motor is used to apply pressure to the brake causing it to release. As soon as the flow ceases the brake is applied automatically by the spring pressure.

REMOTE CONTROL BOOM CIRCUIT

The foregoing description of the boom and rotation hydraulic circuits was for manual operation utilizing the control levers of the distribution block located on the chassis.

The boom and rotation functions can also be operated remotely using the cable remote console controls or the radio remote controls. This is accomplished by electrically actuating the directional valve solenoid to shift the spool instead of direct manual actuation for a particular function. Nothing else changes in the circuit operation.

NOTE

When actuating the control valve using the remote, the valve handle on the direction valve of the function being operated will also move. This is a common occurrence and should not be cause for alarm.

CONCRETE PUMP HYDRAULIC SYSTEM

As previously noted the **MODEL XXT 42** is equipped with two separate independent hydraulic systems. One is designed for the operation of the boom functions and one for operation of the concrete pump. However, within the concrete pump hydraulic system, there are four separate circuits. The four circuits utilized are the **MAIN PUMP** circuit for the material cylinder, the **S-TUBE SHIFT** circuit, **OIL COOLER** circuit and the **AUXILIARY** circuit for operation of the remixer and water pump system.

For the purpose of making it easier to understand the four circuits, which are somewhat related, are presented and described separately:

SPECIFICS – PRESSURES (TEST POINT VALUES BASED ON FULL RPM)

• Maximum System Pressure, Main Pumps	=	5075 PSI (350 Bar)
• Main Pump Charge Pressure	=	493 PSI (34 Bar)
• Low Pressure (Flush Oil)	=	406 PSI (28 Bar)
• S-tube Shift System Pressure	=	2755 PSI (190 Bar)
• Accumulator Pre-Charge Pressure	=	1305 PSI (90 Bar)
• Oil Cooler Fan Relief Pressure	=	800 PSI (56 Bar)
• Agitator System Relief Pressure	=	2900 PSI (200 Bar)
• Water Pump System Relief Pressure	=	2900 PSI (200 Bar)
• Flow to Oil Cooler	=	24 GPM (92LPM)

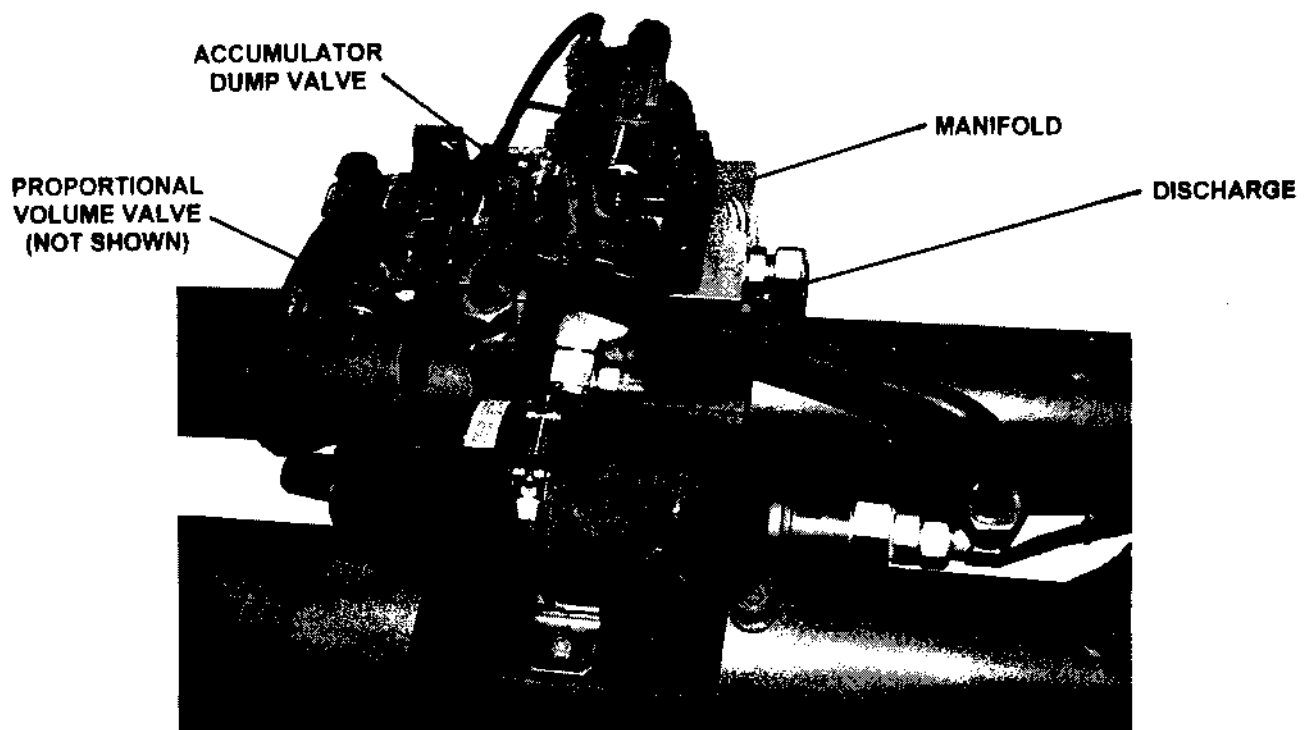

MATERIAL CYLINDER CIRCUIT (Refer to Hydraulic Schematic)

The **MODEL XXT 42** is designed to pump concrete material from the hopper through a delivery system to the placement site. To accomplish this requires the use of two (2) material cylinders that are driven by two (2) hydraulic cylinders and the concrete material pumping action is the result of the two (2) cylinders operating or stroking on an alternate basis. In other words, when one cylinder is retracting, it is drawing, into the material cylinder tube, the concrete material from the hopper. The other cylinder, which has its material cylinder tube already full is extending. This causes the material to be pushed through the swing tube and out into the delivery line system. This reciprocating action continuously takes place while the pump is in **FORWARD**. This is the purpose of the **MAIN PUMP** circuit to provide the hydraulic power for operation of the material cylinders.

The **MAIN PUMP** circuit is of the **CLOSED LOOP** type. In the design of this closed loop circuit, the main ports of the hydraulic pump are connected by a hydraulic line to each of the hydraulic drive cylinders. By making an internal change within the pump during operation from an external control, the flow pressure output direction of the fluid can be directed to flow in either direction. As an example, the hydraulic fluid can be discharged from Port "A" to Cylinder "A" with return fluid from cylinder "B" going back to Port "B" of the pump. When this cycle is complete, then the direction is reversed.

For the **MODEL XXT 42**, two (2) hydraulic pumps are used to meet the volume and pressure requirements of the concrete pumping system. The hydraulic pumps are manufactured by Rexroth and are of the variable displacement axial piston type with a swashplate design. The pistons of the pump run against the swashplate, which is capable of being tilted. This tilting or angle varies the stroke length of the pistons which in turn varies the displacement of the fluid. The larger the angle, the greater the flow. In the case of the **MODEL XXT 42**, the angle of the swashplate is varied by use of the **VOLUME** control that works in conjunction with the **HD** (Hydraulic Displacement) control module and is held constant by a feed back lever connected to the swashplate.

The pumps are driven by the chassis engine through a power take off and are installed in the tandem or series arrangement. They are designated as Front Pump and Rear Pump. Starting the chassis engine and engaging the PTO will place the two (2) main pumps in operation. However, at this point, since no control has been actuated and with no volume demand, the hydraulic pumps are producing a minimal amount of pressure and flow to enable lubrication of the pump. The pumps are at zero position at this time. This condition exists regardless of whether the engine is at idle or maximum RPM.

To energize the material cylinder cycling circuit, the **PUMP** switch must be **ON**. In so doing, an electrical signal is generated which engages the hydraulic pumps to start and direct the flow to the appropriate hydraulic drive cylinder.

Where, how, and why is this electrical signal generated?

It was previously noted that the concrete pumping action is the result of the two (2) material cylinders cycling on an alternate basis. This alternating cycling is controlled by an electrical signal which is generated by the extension and retraction of the hydraulic cylinder designated as **CYL "A"**. This cylinder has installed, at each end of the cylinder barrel, a sensor which is triggered by the cylinder piston head passing underneath the sensor.

The electric signal that is generated by the proximity sensor is sent to the logic controller or which is better known as the black box. The black box is a **REED** proprietary solid state device, designed to control the alternating action of the main pump and to synchronize the movement of the S-tube. The signal from the black box is then sent to the **HD** (Hydraulic Displacement) control valve of the pump circuit.

The **HD** control valve, when energized is used to change the position of the swashplate which is used to direct the flow of fluid to either **CYL "A"** or **CYL "B"** based on the signal received and which sensor was activated. The **HD** control valve is also used to vary the angle of the swashplate which changes the displacement of fluid to either a higher or lower output in proportion to the amount of volume demand placed on it by the volume control potentiometer's electric signal.

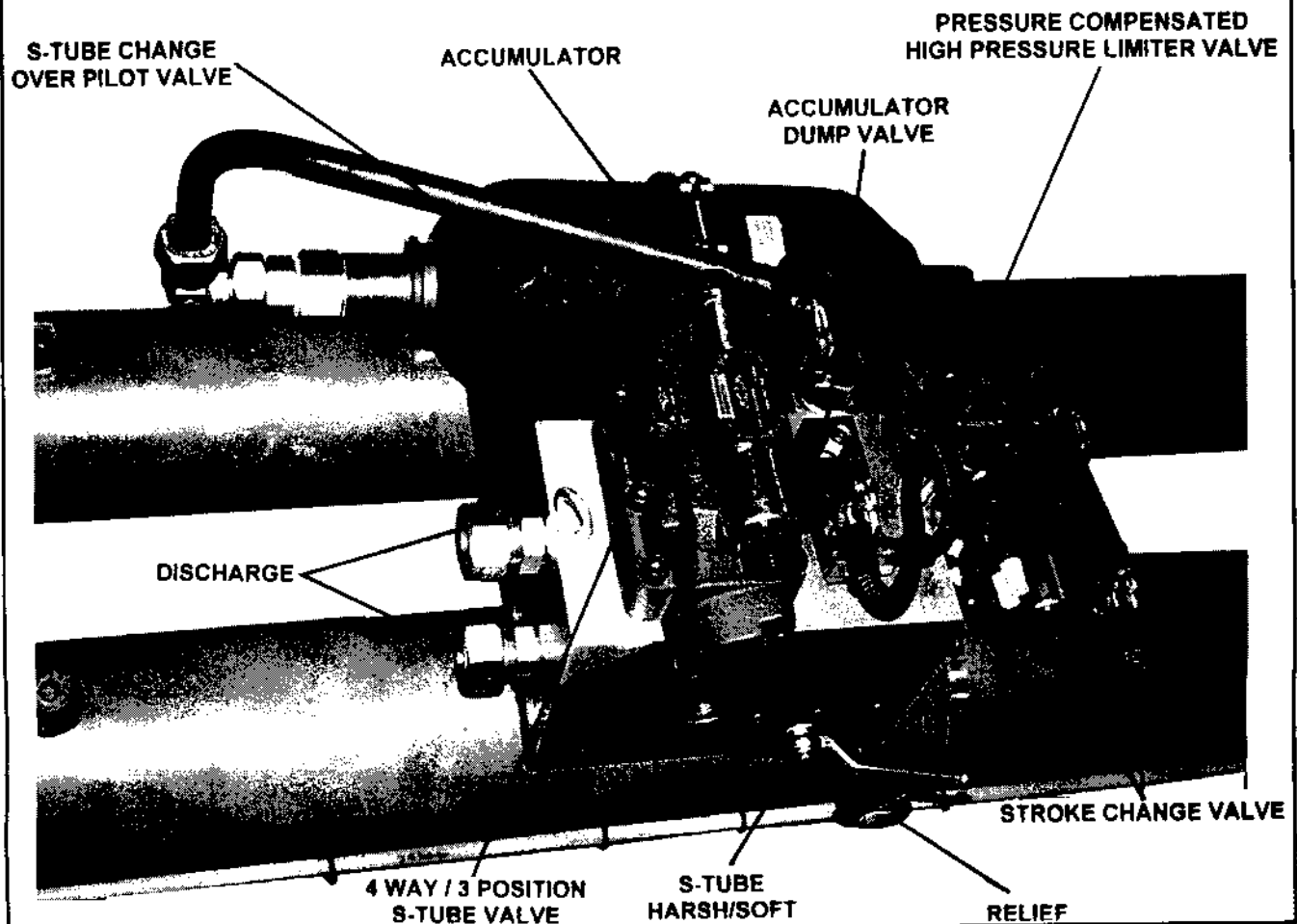

In the cycling of the cylinders, the main pressure and flow is only directed to one end of the hydraulic cylinder. In this instance for the **XXT 42**, it is directed to the rod side. In so doing, it is necessary to connect together the piston ends of both cylinders. The purpose of this is to transfer hydraulic oil from one to the other during extension/retraction stroke. As the rod of one cylinder is retracted, oil is pushed out of the barrel side and directed to the barrel side of the other cylinder forcing it to extend.

In the closed loop system, the same hydraulic fluid is continuously circulated as the loop does not allow for a direct return to tank.

CIRCUIT OPERATIONAL SEQUENCE

In the operational sequence of the **MAIN PUMP CIRCUIT** with the chassis engine running and the PTO engaged, the two (2) main pumps are in operation in a standby state. This condition is due to the fact the pump switch is off and no volume demand exists. When the **PUMP** switch is placed **ON**, and throttle is at the proper **RPM**, the hydraulic cylinders begin to cycle. The stroking speed of the cylinders is dependent on the adjustment of the volume control and engine **RPM**.

NOTE

The pump is operational at engine idle, however, for concrete pump cycling, the engine RPM should be set to at least 1/2 throttle.

The volume control is a potentiometer type control and varies the electrical current signal to the proportional pilot pressure control valve. In operation, a full 12 volt DC signal is sent to the stroke change valve and the appropriate pilot pressure is allowed to signal the **HD** control module. The pilot pressure that exists in the hydraulic circuit is directly related to the position of the potentiometer knob (1 to 8).

S-TUBE SHIFT CIRCUIT (Refer to Hydraulic Schematic)

In the foregoing description of the Main Pump Circuit, we had learned that the hydraulic drive cylinders operate on an alternating basis causing the material cylinders to do the same. Since there is only one outlet for the concrete material, a means is required to transfer the concrete material from the material cylinders to the outlet and into the delivery line. To accomplish this, a component referred to as the S-Tube or swing tube is installed in the hopper. Since there are two material cylinders and one S-tube, the S-tube must be shifted from one material cylinder to the other, whichever one is loaded with the concrete material. Thus the incorporation of the **S-TUBE SHIFT CIRCUIT**.

The S-tube shift hydraulic circuit is of the pressure compensated type, meaning that when the control valves are in the neutral position hydraulic non-operational (unactuated), the internal passages of the valves are closed to all ports. To meet the flow and pressure requirements of the shift circuit, a Rexroth variable displacement axial piston pump of a swashplate design is used. The pump is equipped with a pressure compensator and load limiter device. It is driven by the chassis engine through a PTO. In addition to the hydraulic pump, the shift circuit consists of an unloader solenoid, a relief valve, an accumulator, a solenoid directional valve and two (2) hydraulic cylinders.

The shifting circuit is energized as that of the main circuit by activation of the **PUMP** switch to the **ON** position and receipt of the electrical signal from the proximity switches. As the proximity switch signal is generated, the shift circuit pump comes on stroke producing the required flow and pressure to recharge the accumulator after shifting of S-tube.

In operation the shifting of the S-tube from one material cylinder to the next cylinder requires instant pressure and volume which cannot be obtained by the system itself. To compensate for this, an accumulator is used.

An accumulator is a hydraulic reservoir that retains the hydraulic fluid under high pressure. To accomplish this, the accumulator contains a rubber bladder on the inside of the reservoir. This bladder, at time of installation, before start-up, or upon replacement, must be pre-charged to a certain pressure using nitrogen gas. This expands the bladder much like a balloon. In operation of the circuit, the hydraulic fluid is pumped inside the accumulator shell. This compresses the bladder and the fluid is contained in the reservoir under high tension until released.

SHIFT CIRCUIT OPERATIONAL SEQUENCE

In the operational sequence of the shift circuit with the chassis engine running and PTO engaged when the **PUMP CYCLE** switch is placed to **ON**, an electrical signal activates the solenoid of the dump valve closing the valve. When this occurs, the hydraulic pump goes on stroke and hydraulic fluid now is directed to the accumulator.

As previously described, the proximity sensor generates an electrical signal which is sent to the black box and used to control the hydraulic cylinders and shifting of the S-tube. The electrical signal, when received, activates the solenoid coil of the directional valve shifting the spool to the appropriate side. This allows piloting oil to flow into the 4/3 directional valve on one side or the other causing the larger spool to allow the accumulator flow to pass through to the appropriate "S"-tube shift cylinder. The accumulator then releases, exhausting the fluid which is then directed to the appropriate shift cylinder of the S-tube. As soon as the shift is made, the accumulator is refilled immediately and the sequence starts all over again.

For the shifting of the S-tube, two (2) hydraulic cylinders are used, one for each swing direction. The cylinders are pressurized on the barrel side only. As the fluid is directed to the barrel side of one cylinder to extend the rod, the fluid in the cylinder with the rod already extended is forced out and directed back to tank by the shifting of the other cylinder.

When necessary, the shifting speed of the S-tube cylinders can be adjusted. This is accomplished by use of the levered manual valve installed on the shifting manifold. Closing of valve will cause cylinder to shift at a slow rate as the flow is restricted. With valve open, flow to cylinders is increased causing a faster shift.

AUXILIARY CIRCUIT

The auxiliary circuit is used to operate the oil cooler fan, agitator/remixer, and water pump. Providing the flow and pressure requirements for the auxiliary circuit is a tandem gear type hydraulic pump which is mounted to the back of the shift circuit pump. This pump operates on an open center basis meaning the pump is continually producing the required flow even if no control is actuated. Fluid is directed back to the tank.

- **OIL COOLER CIRCUIT** – This is a straight forward circuit and is used to operate the oil cooler fan motor. Supplying the flow and pressure requirements is the second section of the tandem pump. The operation of the fan motor is controlled by a thermostat which when high temperature setting is reached, it activates the solenoid of the control valve, opening the circuit to allow flow to go to the fan motor. When low temperature is reached the valve closes shutting off the motor. For protection of the system against excessive pressure a relief valve is installed and is set at 800 PSI (56 Bar).
- **AGITATOR/REMIKER CIRCUIT** – This circuit is used to operate the agitator hydraulic motors. The flow and pressure is supplied by the first section of the tandem pump. For operation, the flow from the pump is directed to a manually operated double spooled directional control valve. This is a three (3) position valve section having a detented spool. This means that when the control lever is moved to a particular direction, it will remain in that position until once again moved. A relief valve for each section is incorporated in the valve bank to protect the agitator and water system against excessive pressure.
- **WATER PUMP CIRCUIT** – This unit is equipped with a water system, complete with water tank, water pump, etc. The water pump is driven by a hydraulic motor which is controlled by the second spool section of the same directional control valve used on the agitator system. This valve section is of the two (2) position type which when actuated, directs the flow to the hydraulic motor for operation of the pump.

ELECTRIC SYSTEM

The **MODEL XXT 42** electrical system is in most areas of the ordinary design. The system consists of various switches both momentary and positive position type, key switches, potentiometers, relays, instruments and lighting.

The **XXT 42** utilizes a 12 volt direct current system with a negative ground. All electrical components operate directly from the 12 volt source.

The 12 volt power source is provided by the chassis batteries and kept in the charged state by the chassis alternator.

Refer to the Electrical Schematics for specifics on the systems.



3.5 Conversion and replacement of wear parts

3.5.1 Replacement of wear plate and wear ring

ATTENTION: Always stop the engine and remove the ignition key if you work inside the hopper or in the surroundings of the tilting cylinders.

1. Remove safety plate (1) at the tilting lever. Release the s-valve by opening the screws (2) and (3) for about 15 mm.

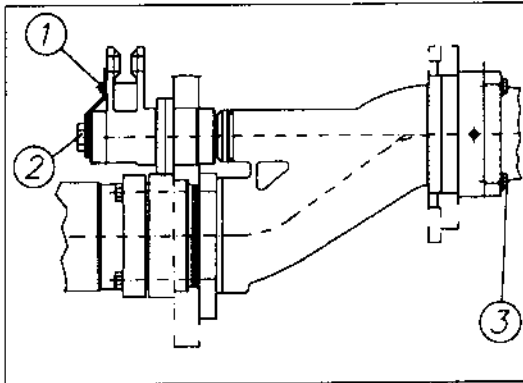

2. Exchange the released wear plate by removing the 4 screws (4) and tighten the bolts again.

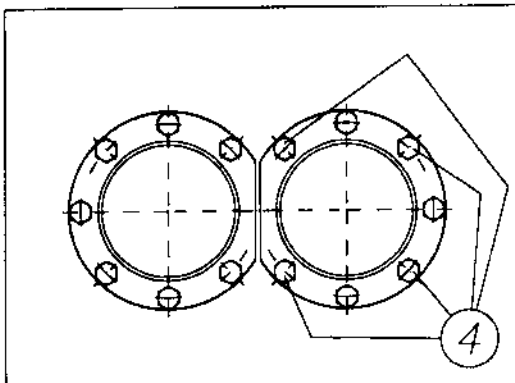

3. Swing the s-valve to the other side..

4. Take out the second wear plate by removing the 4 screws (4).
 5. Swing the s-valve back and exchange the wear ring (5).
 6. Swing the s-valve up to the mounted wear plate and assemble the second one.
 7. Give tension to the s-valve by tighten the 4 screws (3).
 8. Tighten the adjusting screw (2) by hand until there is no gap anymore. Release this screw for 1/6 at least and assemble the safety plate (1).
- ATTENTION:** Tighten the screws (3) and (4) with tightening torque. (See attached table for torque's).

9. Carry out a test run.

3.5.2 Replacement of conveyor pistons

ATTENTION: Always stop the engine and remove the ignition key if you work inside the water box. Do never grab inside the water box as long as the engine is running. Do the hydraulic cylinders drive always by using manual driving with the valves at the main control block. Use low r.p.m.

1. Drain the water box and remove the safety grid..
2. Move one drive cylinder by activating the valves Y3 and Y4 to end position.

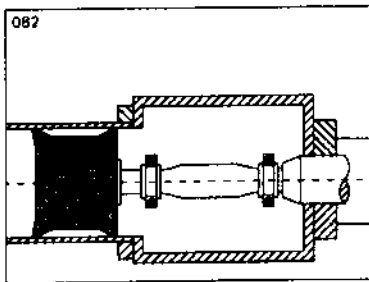

3. Open and remove the hose clamp and the clamp coupling.
4. Push the conveyor piston about 5mm in direction of conveyor cylinder and remove the spacer.

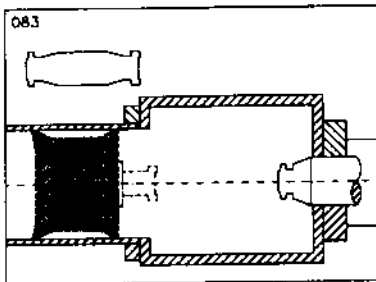

Drive the drive cylinder carefully out until the flanges touch each other and assemble a clamp coupling.

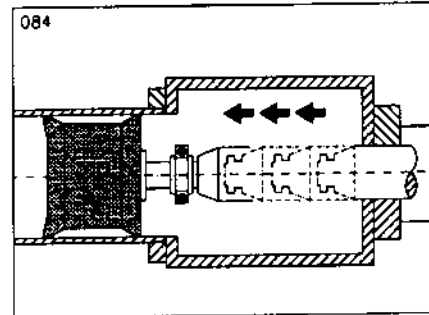

6. Bring the drive cylinder to end position and disassemble the clamp coupling and the piston.

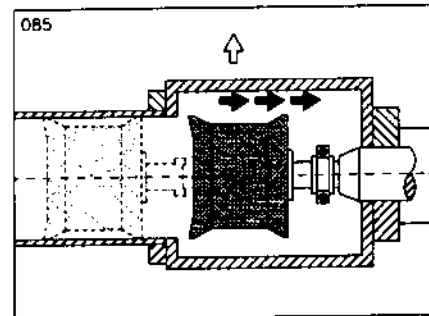

7. Lubricate the new conveyor piston well with grease and assemble it with one clamp coupling.

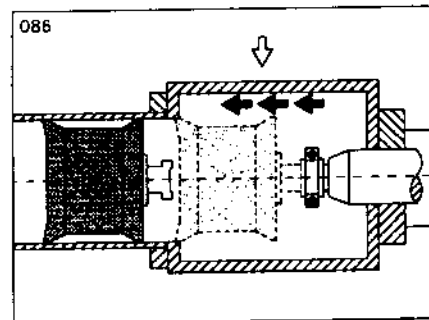

8. Drive the drive cylinder into the conveyor cylinder as long as there is enough space to assemble the spacer.
9. Remove the clamp coupling and drive the cylinder back to end position.
10. Assemble the spacer with the clamp coupling and the hose clamp onto the drive cylinder.

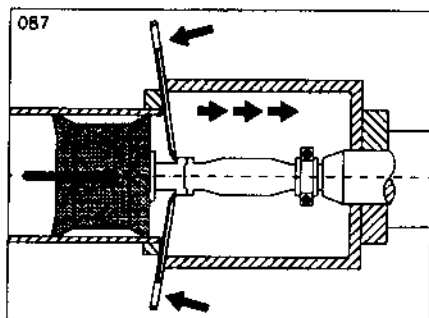

11. Push the piston in direction to the spacer and mount the second clamp coupling and clamp.

3.5.3 Replacement / turning of conveyor cylinders

1. Disassemble conveyor piston(see 3.5.3)
2. Bring both drive cylinders hydraulically to end position: Open the hydraulic swing hose at the driven in drive cylinder and fix a bucket at the hose.
3. Disassemble the axle and support the water box.
4. Remove the 28 screws(1) at the 4 flanges of the two conveyor cylinders and support the cylinders.(The easiest way would be with the fork lift)

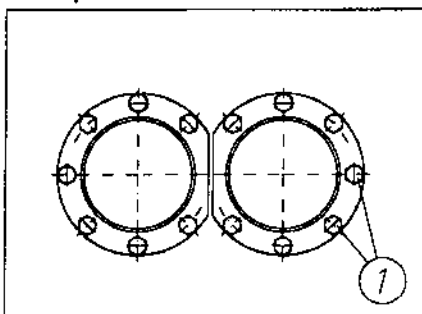

Lift the hopper by crane.

ATTENTION: Take care that you don't squeeze hydraulic hoses or electrical cables during lifting.

5. Disassemble or turn the conveyor cylinders.
Hint: In order to increase the life time of cylinders you can turn them for 180°. It is

very important to turn the cylinders in time, before the wear out is too big, because than you have to exchange them completely.

6. Assemble the conveyor cylinders in opposite order.
7. Assemble the pistons (see 3.5.3) and the hydraulic swing hose again.
8. Drive the right drive cylinder out by activating the valves Y4a and Y3. (look at 3.1.4)
9. Take out the air from the swing hose. (see 3.1.4)
10. Start a test run.

3.5.4 Replacement of the agitator tool

1. Remove the cylindrical screws(6).
2. Push the shaft (3) against the motor (1).
3. Exchange the agitator tools (2 and 5).
4. Assemble the screws (6) and tighten it.
5. Fill the inner hex gap of the cylindrical screws with silicon to protect against concrete .

