

CODE NO.	REED'S PARTS NO.	DESCRIPTION					QTY
		1	2	3	4	5	
1	C-.SE	Tank, Hydraulic Oil					1
2	C-.WR	Valve, Inlet					1
3	C-.FF1	Hose, Flexible					1
4	C-.MP	Pump, Hydraulic					1
5	C-.FF2	Hose, Flexible					1
6	C-DM000	Gauge, Pressure					1
7	C-FF143.100	Hose, Flexible					1
8	C-DF101	Filter, Hydraulic					1
9	C-DD001/DD002	Distributor					1
10	C-FF101.080	Hose, Flexible					2
11	C-FF122.440	Hose, Flexible					8
12	C-FF122.125	Hose, Flexible					10
13	C-WL210	Valve, Flow Limiter					1
14	C-WL213	Valve, Flow Limiter					1
15	C-FF122.070	Hose, Flexible					24
16	C-WC120	Valve, Check					1
17	C-WC125	Valve, Check					1
18	C-.B4	Piston, Hydraulic					1
19	C-WL215	Valve, Flow Limiter					1
20	C-WL128	Valve, Check					6
21	C-.B3	Piston, Hydraulic					1
22	C-WL220	Valve, Flow Limiter					1
23	C-.B2	Piston, Hydraulic					1
24	C-WL218	Valve, Flow Limiter					1
25	C-.B1	Piston, Hydraulic					1
26	C-FF122.160	Hose, Flexible					2
27	C-WA105	Valve, Over Center					1
28	C-.MI	Motor, Hydraulic					1
29	C-FF101.045	Hose, Flexible					1
30	C-FF134.070	Hose, Flexible					8
31	C-DD009	Distributor					2



HYDRAULIC SCHEMATIC (OUTRIGGER AREA)

SCMTC

PAGE 02

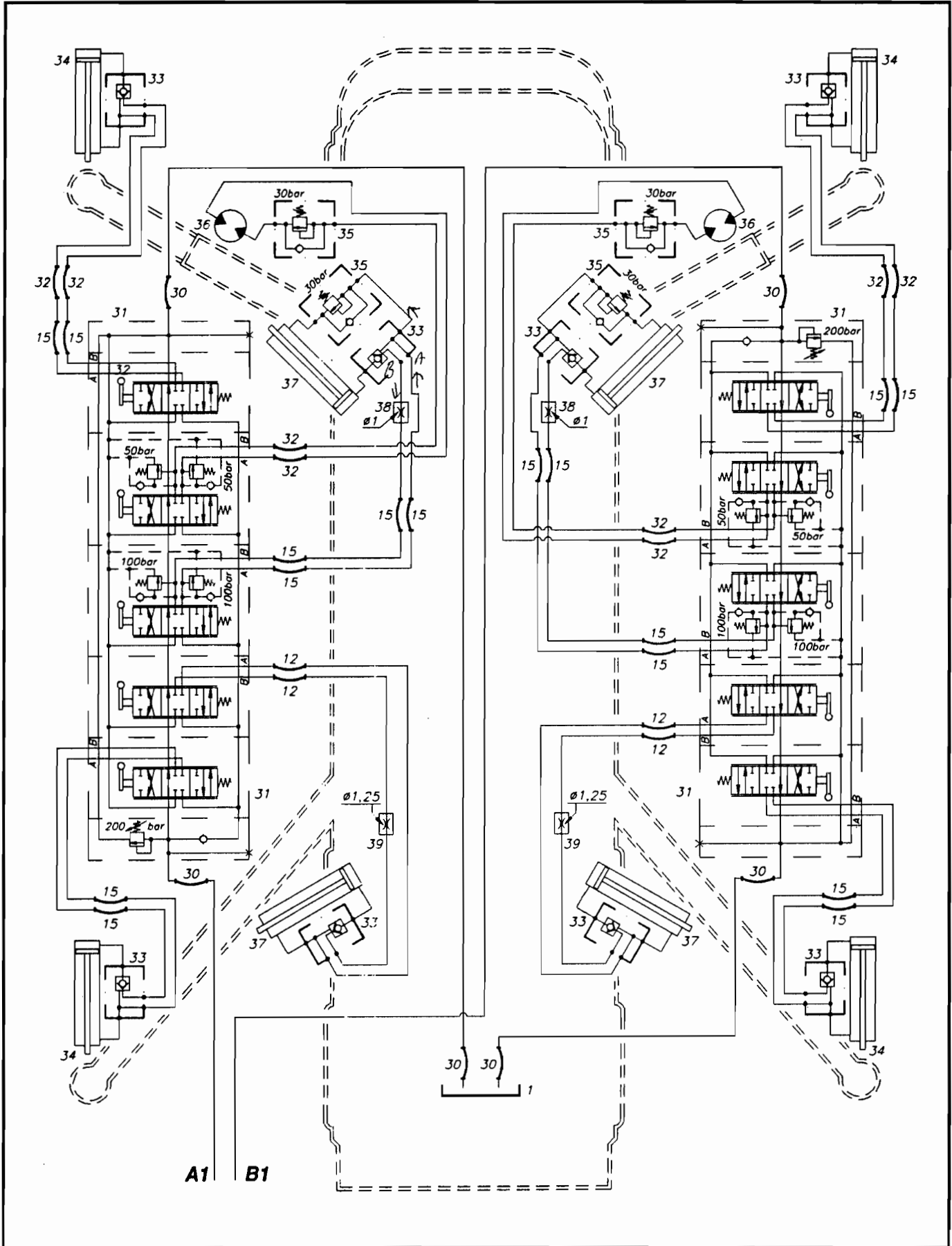

REVISION:

CODE NO.	REED'S PARTS NO.	DESCRIPTION					QTY
		1	2	3	4	5	
32	C-FF122.170	Hose, Flexible					8
33	C-WD101	Valve, Check					8
34	C-.L5	Piston, Hydraulic					4
35	C-WS103	Valve, Sequence					4
36	C-.MI1	Motor, Hydraulic					2
37	C-.M3	Piston, Hydraulic					4
38	C-WL110	Valve, 2 Direction Throttle					2
39	C-WL112	Valve, 2 Direction Throttle					2

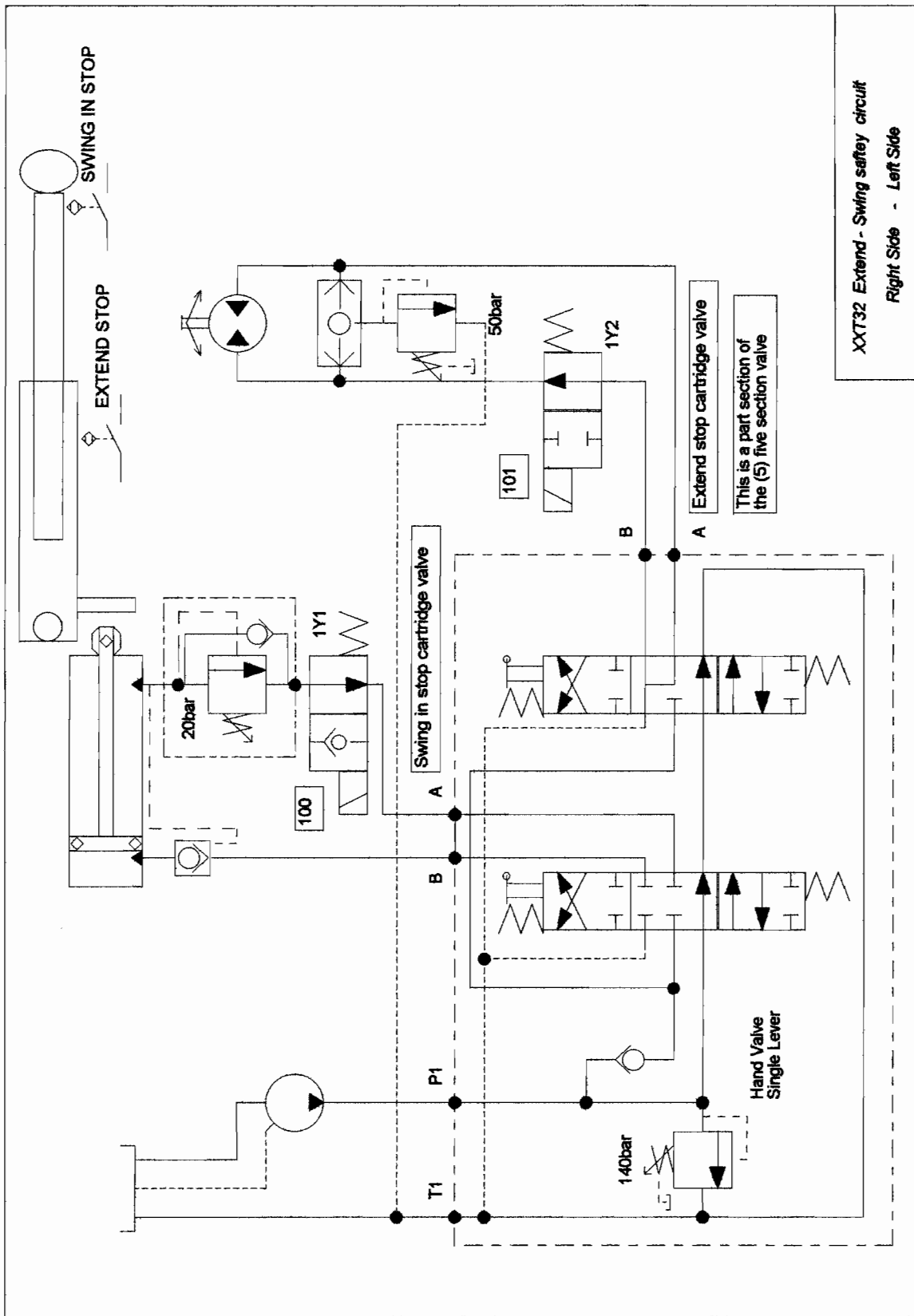

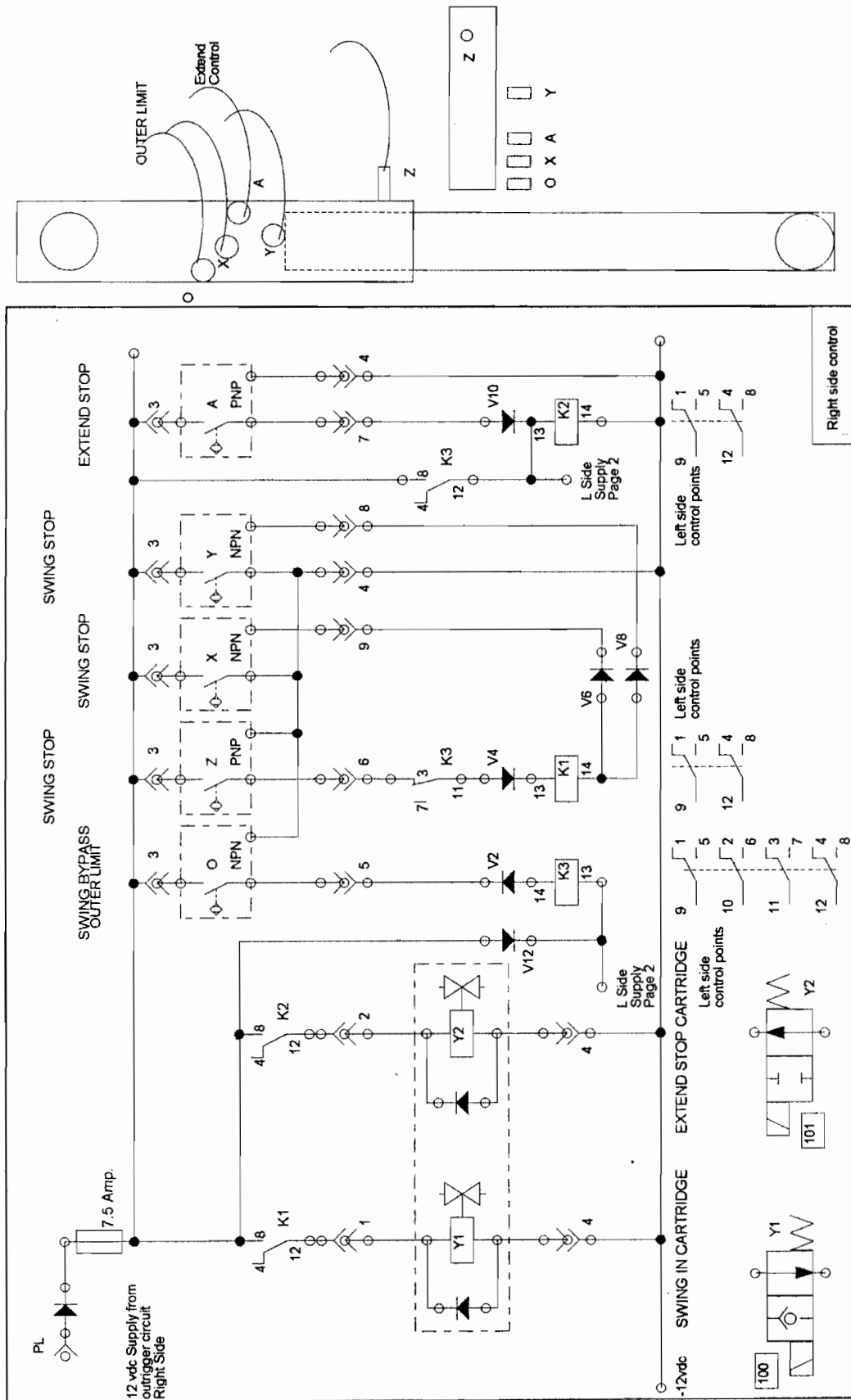



ELECTRIC SCHEMATIC (LEFT SIDE CONTROL)

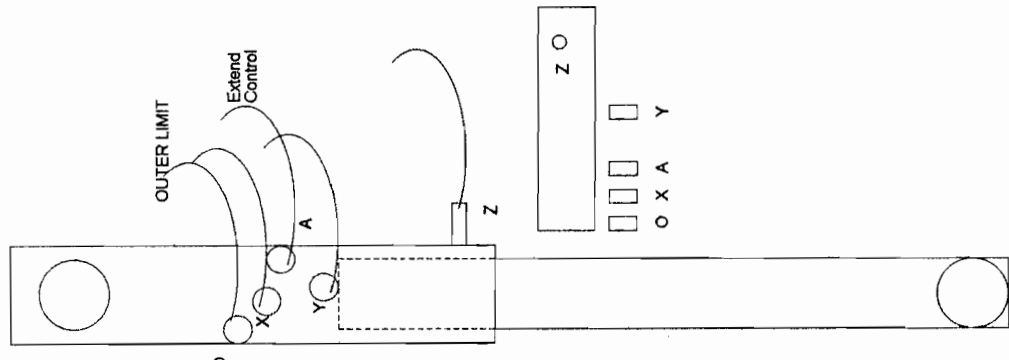
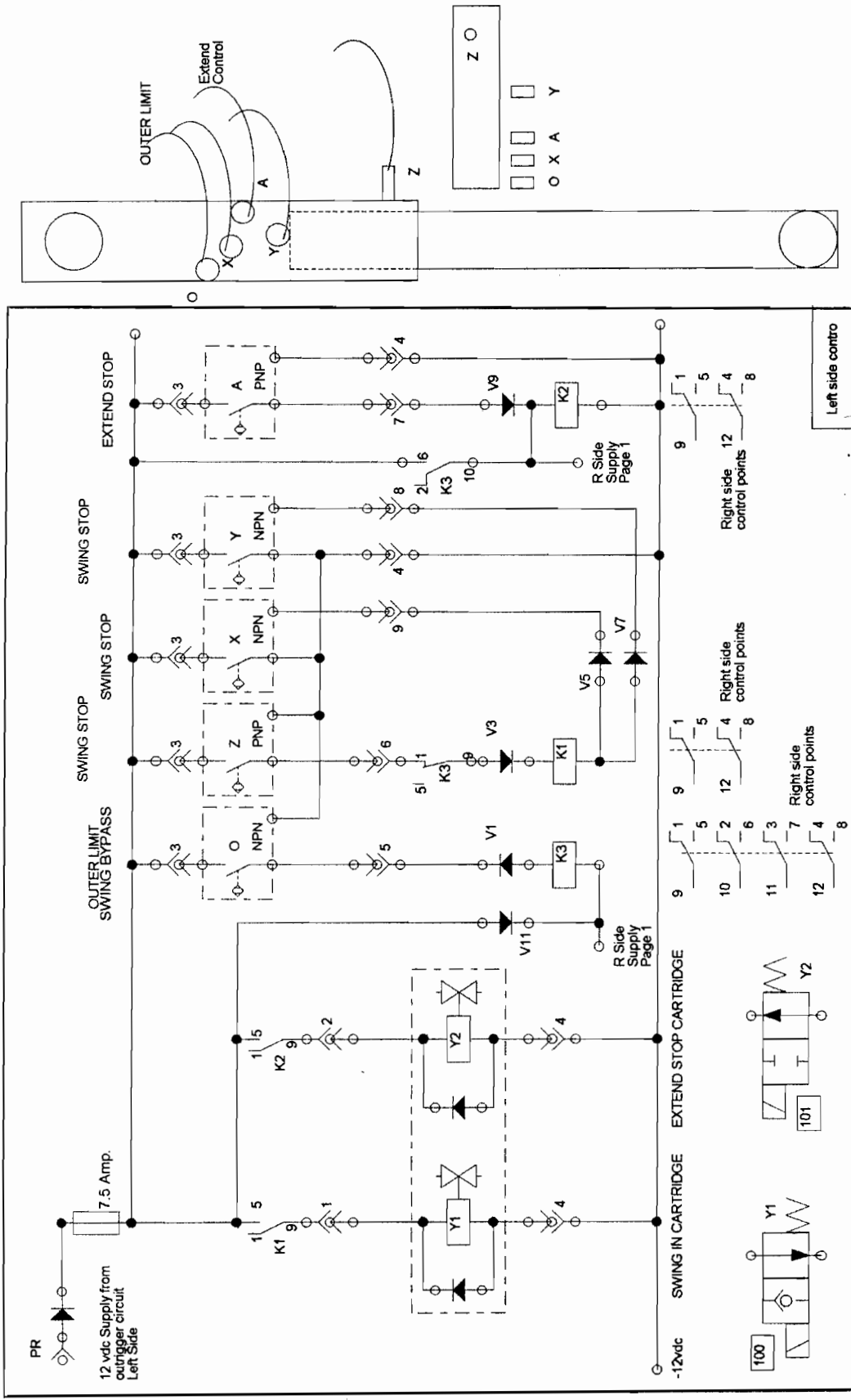

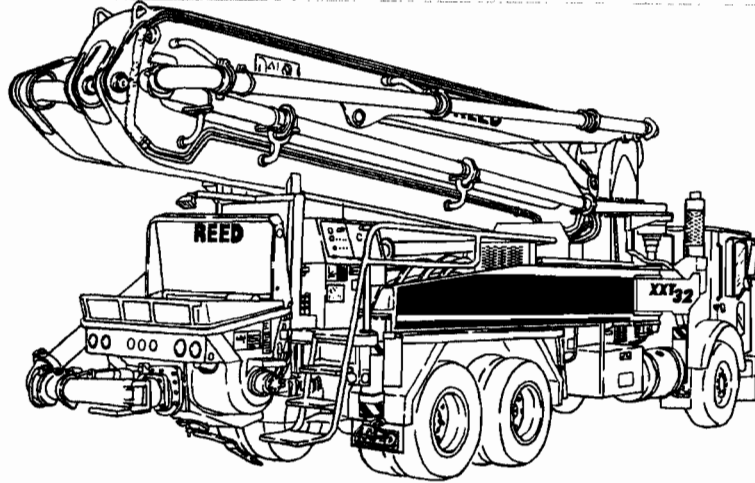

REED TRUCK MOUNTED CONCRETE BOOM PUMP MODEL XXT 32 ILLUSTRATED PARTS MANUAL CONTAINS THE FOLLOWING GROUPS AND FIGURES:

GROUP 00 HOW TO USE PARTS MANUAL

- FIGURE 00 TABLE OF CONTENTS
- FIGURE 01 HOW TO USE PARTS MANUAL
- FIGURE 02 HOW TO ORDER PARTS

GROUP 10 FINAL INSTALLATION

- FIGURE 00 TABLE OF CONTENTS
- FIGURE 01 FINAL INSTALLATION
- FIGURE 02 DECAL ASSEMBLY

GROUP 20 HOPPER INSTALLATION

- FIGURE 00 TABLE OF CONTENTS
- FIGURE 01 HOPPER INSTALLATION
- FIGURE 02 CENTRAL LUBRICATION SYSTEM
- FIGURE 03 LUBRICATION PUMP ASSEMBLY
- FIGURE 04 HOPPER VIBRATION ASSEMBLY
- FIGURE 05 AGITATOR ASSEMBLY
- FIGURE 06 AGITATOR DRIVE MOTOR ASSEMBLY
- FIGURE 07 HOPPER OUTLET ASSEMBLY

GROUP 30 TANK INSTALLATION

- FIGURE 00 TABLE OF CONTENTS
- FIGURE 01 TANK INSTALLATION
- FIGURE 02 WATER SYSTEM GROUP
- FIGURE 03 WASH WATER PUMP ASSEMBLY
- FIGURE 04 WATER PUMP MOTOR ASSEMBLY

GROUP 40 POWER TRAIN INSTALLATION

- FIGURE 00** TABLE OF CONTENTS
- FIGURE 01** POWER TRAIN INSTALLATION (BEF JUL 1999)
- FIGURE 02** POWER TRAIN INSTALLATION (AUG 1999 ~ MAR 2000)
- FIGURE 03** POWER TRAIN INSTALLATION (APR 2000 ~ FEB 2001)
- FIGURE 04** POWER TRAIN INSTALLATION (AFT MAR 2001)
- FIGURE 05** GEAR PUMP ASSEMBLY
- FIGURE 06** PTO GEARBOX ASSEMBLY

GROUP 50 CONTROLS INSTALLATION

- FIGURE 00** TABLE OF CONTENTS
- FIGURE 01** CONTROLS INSTALLATION (BEF MAY 2000)
- FIGURE 02** CONTROLS INSTALLATION (AFT JUN 2000)
- FIGURE 03** CAB CONTROLS ASSEMBLY
- FIGURE 04** MAIN CONTROLS ASSEMBLY (BEF MAY 2000)
- FIGURE 05** MAIN CONTROLS ASSEMBLY (AFT JUN 2000)
- FIGURE 06** LH SIDE OUTRIGGER CONTROLS ASSEMBLY (BEF MAY 2000)
- FIGURE 07** LH SIDE OUTRIGGER CONTROLS ASSEMBLY (AFT JUN 2000)
- FIGURE 08** RH SIDE OUTRIGGER CONTROLS ASSEMBLY (BEF MAY 2000)
- FIGURE 09** RH SIDE OUTRIGGER CONTROLS ASSEMBLY (AFT JUN 2000)
- FIGURE 10** STATIONARY BOOM CONTROLS ASSEMBLY
- FIGURE 11** CABLED REMOTE CONTROL ASSEMBLY (BEF MAY 2000)
- FIGURE 12** CABLED REMOTE CONTROL ASSEMBLY (AFT JUN 2000)
- FIGURE 13** RADIO REMOTE CONTROL ASSEMBLY (BEF MAY 2000)
- FIGURE 14** RADIO REMOTE CONTROL ASSEMBLY (AFT JUN 2000)
- FIGURE 15** SHUNT ASSEMBLY

GROUP 60 PUMPING TRAIN INSTALLATION

- FIGURE 00** TABLE OF CONTENTS
- FIGURE 01** PUMPING TRAIN INSTALLATION
- FIGURE 02** SWING VALVE ASSEMBLY
- FIGURE 03** TILTING DRIVE ASSEMBLY
- FIGURE 04** TILTING CYLINDER ASSEMBLY
- FIGURE 05** CONCRETE CYLINDER ASSEMBLY
- FIGURE 06** WATER BOX ASSEMBLY
- FIGURE 07** HYDRAULIC DRIVE CYLINDER ASSEMBLY
- FIGURE 08** DRIVE CYLINDER SUB-ASSEMBLY

GROUP 70 FRAME AND SUPPORT INSTALLATION

FIGURE 00	TABLE OF CONTENTS
FIGURE 01	FRAME AND SUPPORT INSTALLATION
FIGURE 02	TURRET ASSEMBLY
FIGURE 03	MOTOR AND REDUCTION ASSEMBLY
FIGURE 04	ROTATION UNIT ASSEMBLY
FIGURE 05	SUPPORT FRAME STABILIZERS ASSEMBLY
FIGURE 06	FRONT LEFT STABILIZERS TELESCOPIC LEG ASSEMBLY
FIGURE 07	FRONT RIGHT STABILIZERS TELESCOPIC LEG ASSEMBLY
FIGURE 08	REAR LEFT SWING OUT LEG ASSEMBLY
FIGURE 09	REAR RIGHT SWING OUT LEG ASSEMBLY
FIGURE 10	STABILIZERS VERTICAL JACK CYLINDER ASSEMBLY
FIGURE 11	SWING OUT CYLINDER ASSEMBLY

GROUP 80 OPTIONAL INSTALLATION

FIGURE 00	TABLE OF CONTENTS
FIGURE 01	OPTIONAL INSTALLATION
FIGURE 02	ACCUMULATOR CHARGE KIT
FIGURE 03	OPTIONAL TOOL KIT ASSEMBLY

GROUP 90 BOOM INSTALLATION

FIGURE 00	TABLE OF CONTENTS
FIGURE 01	BOOM INSTALLATION
FIGURE 02	FIRST BOOM ASSEMBLY
FIGURE 03	SECOND BOOM ASSEMBLY
FIGURE 04	THIRD BOOM ASSEMBLY
FIGURE 05	FOURTH BOOM ASSEMBLY
FIGURE 06	FIRST BOOM CYLINDER ASSEMBLY
FIGURE 07	SECOND BOOM CYLINDER ASSEMBLY
FIGURE 08	THIRD BOOM CYLINDER ASSEMBLY
FIGURE 09	FOURTH BOOM CYLINDER ASSEMBLY
FIGURE 10	CONCRETE DECK PIPELINE ASSEMBLY
FIGURE 11	CONCRETE BOOM PIPELINE ASSEMBLY



MODEL **XXT 32** TRUCK MOUNTED CONCRETE BOOM PUMP HOW TO USE PARTS MANUAL

XXT 32
PARTS
GROUP 00
FIGURE 01
PAGE 01

I. PURPOSE

This parts manual is prepared, issued and/or revised by **REED** Manufacturing, for the exclusive use of its customers and is intended for use in provisioning, requisitioning, storing and issuing replaceable **REED** truck mounted concrete boom pump model **XXT 32**. The contents are proprietary to **REED** and are subject to change without notice. The use of any part of this document by any other person or persons or for any other purpose without the written consent of **REED** is expressly prohibited. In addition, **REED** expressly disclaims any and all responsibility arising in or any way related to such **REED'S** prior written consent thereto.

The parts number content of this document, arrangement and breakdown sequence of items is compatible with Military Standard (**MS**) and Air Transport Association Specification (**ATA**).

II. GENERAL SYSTEM OF ASSEMBLY ORDER - Detailed Parts List (Refer to Next Page)

1. This area refers to the corresponding illustration

MODEL - GROUP - FIGURE - PAGE

A. **MODEL** shows which is **REED'S** model number.

B. **GROUP** should be divided with:

00	MODEL XXT 32 ILLUSTRATED PARTS MANUAL
10	FINAL INSTALLATION
20	HOPPER INSTALLATION
30	TANK INSTALLATION
40	POWER TRAIN INSTALLATION
50	CONTROL INSTALLATION
60	PUMPING TRAIN INSTALLATION
70	FRAME AND SUPPORT INSTALLATION
80	OPTIONAL INSTALLATION
90	BOOM INSTALLATION

C. **FIGURE** belong to the group. Please see page of contents and each group.

D. **PAGE** numbers follow to the right of each figure number.

2. The **ITEM NUMBER** corresponds to the item number shown for the part in illustration. Parts with item number preceded by a dash (such as: -1, -5, -12 etc.) are not illustrated.

3. **PARTS NUMBERS** that carry a **REED** part number.



MODEL XXT 32 TRUCK MOUNTED CONCRETE BOOM PUMP HOW TO USE PARTS MANUAL

**XXT 32
PARTS
GROUP 00
FIGURE 01
PAGE 02**



HYDRAULIC PUMPING ASSEMBLY

**XXT 32
PARTS
GROUP 80
FIGURE 08
PAGE 02**

ITEM NO.	REED'S PARTS NO.	DESCRIPTION	1 2 3 4 5					QTY
-1	60-06	Assembly, Hydraulic Pumping (See Group 20, Figure 01 for NHA)						Ref
2	78354	• Cup, Piston						2
3	78444	• Coupler						2
4	78352	• Coupling, Dog bone						4
5		• Bolt 1/2 x 4 (attaching parts)						8
6		• Nut, 1/2 (attaching parts)						8
7	78443	• Bone, Dog						2
8		• Bolt 5/8 x 2						6
9	78442	• Coupler						2
10	78438	• Assembly, Hydraulic Cylinder (See Group 60, Figure 07 for DET)						1
11		• Nut (attaching parts)						16
12		• Washer (attaching parts)						16
13	77617	• Bolt (attaching parts)						16
14		• Elbow, 90 FS6802-16-16						4
15	79343	• Assembly, Hose						2
16	78593	• Fitting, MiniCheck (Port)						2
17		• Elbow, 90 FS6802-06-06						4
18		• Fitting, STR FS6400-06-06						4
19	79344	• Assembly, Hose						2
20		• Elbow, 90 FS6801-06-06						4
21		• Valve, Check						4
22		• Elbow, 90 MBMB90-06-06						4
23		• Clamp						3
24	79326	• Tube, Wire						1
25	79345	• Assembly, Tube						2
26	78417	• Cable						2
27	72010	• Loom, 1/2 Flex						A/R
28		• Pin, 1/4 x 20						4
29	79285	• Cover, Proximity Switch						2
30	78416	• Switch, Proximity						2
31	79327	• Plate, End						1
32		• Washer, 1 Lock (attaching parts)						8
33		• Bolt, 1 x 2 Course (attaching parts)						8

DASH (-) ITEM NOT ILLUSTRATED

REVISION:



REVISION:



MODEL XXT 32 TRUCK MOUNTED CONCRETE BOOM PUMP HOW TO USE PARTS MANUAL

**XXT 32
PARTS
GROUP 00
FIGURE 01
PAGE 03**



REED
CONCRETE PLACING
EQUIPMENT

HYDRAULIC PUMPING ASSEMBLY

**XXT 32
PARTS
GROUP 60
FIGURE 06
PAGE 02**

ITEM NO.	REED'S PARTS NO.	DESCRIPTION					QTY
		1	2	3	4	5	
-1	60-06	Assembly, Hydraulic Pumping (See Group 20, Figure 01 for NHA)					Ref
2	78354	• Cup, Piston					2
3	78444	• Coupler					2
4	78352	• Coupling, Dog bone					4
5		• Bolt 1/2 x 4 (attaching parts)					8
6		• Nut, 1/2 (attaching parts)					8
7	78443	• Bone, Dog					2
8		• Bolt 5/8 x 2					6
9	78442	• Coupler					2
10	78438	• Assembly, Hydraulic Cylinder (See Group 60, Figure 07 for DET)					1
11		• Nut (attaching parts)					16
12		• Washer (attaching parts)					16
13	77617	• Bolt (attaching parts)					16
14		• Elbow, 90 FS6802-16-16					4
15	79343	• Assembly, Hose					2
16	78593	• Fitting, MiniCheck (Port)					2
17		• Elbow, 90 FS6802-06-06					4
18		• Fitting, STR FS6400-06-06					4
19	79344	• Assembly, Hose					2
20		• Elbow, 90 FS6801-06-06					4
21		• Valve, Check					4
22		• Elbow, 90 MBMB90-06-06					4
23		• Clamp					3
24	79326	• Tube, Wire					1
25	79345	• Assembly, Tube					2
26	78417	• Cable					2
27	72010	• Loom, 1/2 Flex					A/R
28		• Pin, 1/4 x 20					4
29	79285	• Cover, Proximity Switch					2
30	78416	• Switch, Proximity					2
31	79327	• Plate, End					1
32		• Washer, 1 Lock (attaching parts)					8
33		• Bolt, 1 x 2 Course (attaching parts)					8

DASH (-) ITEM NOT ILLUSTRATED

REVISION:



REVISION:



MODEL XXT 32 TRUCK MOUNTED CONCRETE BOOM PUMP HOW TO USE PARTS MANUAL

XXT 32
PARTS
GROUP 00
FIGURE 01
PAGE 04

4. DESCRIPTION

A. The **INDENTURE SYSTEM** used in the parts list shows the relationship of one part to another. For a given item, the number of indentures depicts the relationship of the item to the components of the item as follows:

1 2 3 4 5

Assembly (or Installation)

- Detail part of assembly
- Sub-assembly
- Attaching parts for sub-assembly
- ● Detail part of sub-assembly
- ● Sub-sub-assembly
- ● Attaching parts for sub-sub-assembly
- ● ● Detail part of sub-sub-assembly
- ● ● Sub-sub-sub-assembly
- ● ● Attaching parts of sub-sub-sub-assembly
- ● ● ● Detail part of sub-sub-sub-assembly

B. "See Group 20, Figure 01 For **NHA**"

Identifies the illustrated parts chapter location; indicates where the Next Higher Assembly (**NHA**) of the item shown.

C. "See Group 60, Figure 07 For **DET**"

Identifies the illustrated parts chapter location; indicates where the item and its Detailed Breakdown (**DET**) is shown.

D. "See Group 30, Figure 05 for **REF**" or "See Vendor Chapter For **REF**"

Identifies the illustrated parts chapter where the part is, and if listed and illustrated in Vendor Chapter. It is used as a cross-reference (**REF**).

5. QUANTITY

A. Reference (**REF**) indicates the items that is listed previously in the Next Higher Assembly (**NHA**) and then again in this figure.

B. As Required (**A/R**) indicates the parts that is used in a quantity as required.

C. A number entry indicates the quantity of the part used in its next higher application.

6. Functionally related assemblies are illustrated in phantom (_____) but not listed on the detail parts list page.



MODEL XXT 32 TRUCK MOUNTED CONCRETE BOOM PUMP HOW TO ORDER PARTS

**XXT 32
PARTS**
GROUP 00
FIGURE 02
PAGE 01

- Always give serial number and model of **REED** truck mounted concrete boom pump model: **XXT 32**. (Refer to each unit name plate shown below). NOTE: This manual is being released to cover unit starting with serial number **99 - 181 - XXT 32** to current production. Some components used on earlier units differ from current productions. Where this occurs, the part is identified by a serial number.

REED 13822 OAKS AVENUE CHINO, CA 90710 USA		PHONE (909) 384-2100 FAX (909) 384-2140	CE
MODEL	<input type="text"/>	SERIAL NO.	<input type="text"/>
HYD. PRESSURE	<input type="text"/>	PSI	<input type="text"/>
		BAR	<input type="text"/>
ELECTRIC MOTOR/ ENGINE SPEED	<input type="text"/>	RPM	<input type="text"/>
		VOLTS	<input type="text"/>
VEHICLE WEIGHT (APPROX.)	<input type="text"/>	LBS	<input type="text"/>
		KG	<input type="text"/>

75009A

- Always specify part number and complete name of parts ordered.
 - Turn to table of content in the desired Installation. Refer to main group in which part should be listed.



 CONCRETE PLACING
EQUIPMENT

GROUP 60 PUMP TRAIN INSTALLATION

**XXT 32
PARTS**
 GROUP 60
 FIGURE 00
 PAGE 01

THIS GROUP 60 PUMP TRAIN INSTALLATION CONTAIN THE FOLLOWING FIGURES.

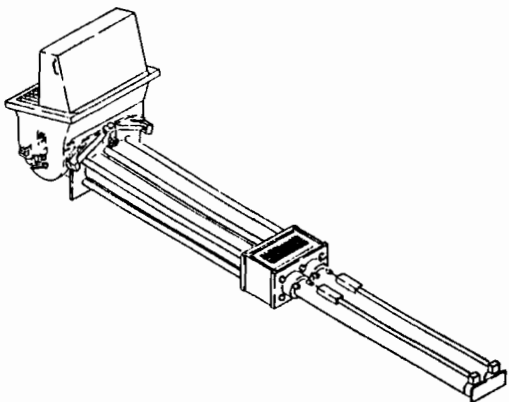
FIGURE 00	TABLE OF CONTENTS
FIGURE 01	PUMP TRAIN INSTALLATION
FIGURE 02	SWING TUBE ASSEMBLY
FIGURE 03	SWING RAM ASSEMBLY
FIGURE 04	SWING RAM CYLINDER ASSEMBLY
FIGURE 05	CONCRETE CYLINDER ASSEMBLY
FIGURE 06	HYDRAULIC PUMPING ASSEMBLY
FIGURE 07	HYDRAULIC PUMPING CYLINDER ASSEMBLY



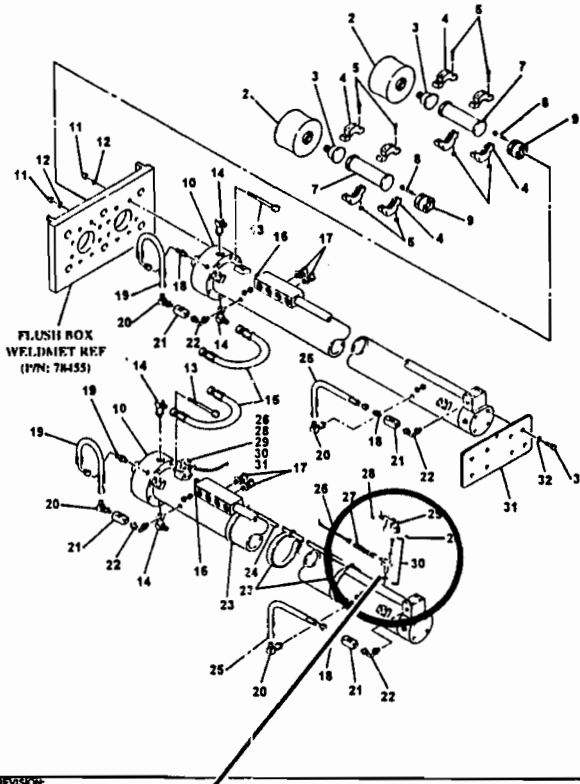

REVISION:

ITEM NO.	REED'S PARTS NO.	DESCRIPTION	QTY
1	60-06	Assembly, Hydraulic Pump (See Group 20, Figure 1 for NHA)	Ref
2	78354	* Cup, Piston	2
3	78434	* Coupler	2
4	78352	* Coupling, Drag by	4
5		* Bolt 1/2 x 4 (attaching parts)	8
6		* Nut, 1/2 (attaching parts)	8
7	78441	* Hose, Drag	2
8		* Bolt 5/8 x 2	6
9	78442	* Coupler	2
10	78438	* Assembly, Hydraulic Cylinder (See Group 00, Figure 07 for DET)	1
11		* Nut (attaching parts)	16
12		* Washer (attaching parts)	16
13	77617	* Bolt (attaching parts)	16
14		* Elbow, 90 FSA002-16-16	4
15	79343	* Assembly, Hose	2
16	78593	* Fitting, Minicheck (Port)	2
17		* Elbow, 90 FSA002-06-06	4
18		* Fitting, STD FSA0010-06	4
19	79344	* Assembly, Hose	2
20		* Elbow, 90 FSA001-06-06	4
21		* Elbow, Check	4
22		* Elbow, 90 MBM100-06-06	4
23		* Clamp	3
24	79326	* Tube, Wire	1
25	79345	* Assembly, Tube	2
26	78417	* Cable	2
27	72010	* Lawn, 1/2 Flat	A/R
28		* Pin, 1/4 x 20	4
29	79385	* Cover, Proximity Switch	2
30	78416	* Switch, Proximity	2
31	78455	* Flush Box Weldment	1
32		* Washer, 1 Lock (attaching parts)	8
33		* Bolt, 1 x 2 Course (attaching parts)	8

DASH (-) ITEM NOT ILLUSTRATED

REVISION:

- B. Find title of figure in which the part should be shown. Note figure number.
- C. Turn to corresponding page, find the group and figure.
- D. Check your required part and its attaching parts and match with illustration page.
- E. Refer to corresponding item number in the part list page. Part numbers are located in the part number column.
- F. When ordering variable or optional miscellaneous parts which are not found this in parts chapter, follow the above outlined procedure of how to order parts.
 - 1). When applicable, give model and serial number of the component for which parts are desired.
 - 2). In a specific, difficult to describe situation, a marked-up photograph or detailed sketch would be helpful.

3. Do not designate quantity by "set". State specifically how many parts are wanted.
4. Always give complete address and full shipping instructions. Specify shipping instructions, truck freight, air freight. United Parcel Service (UPS), or Air Borne Express and DHL are available in designated areas.

5. TO ORDER**A. BY MAIL**

Attention: Parts Department
REED
13822 Oaks Avenue
Chino, CA. 91710

B. BY FAX

(909) 287 - 2141

C. BY PHONE

(909) 287 - 2100

6. Parts return without authorization will not be accepted. If it is necessary to return parts for any reason, written authorization may be obtained from **REED** Parts Department, Chino, CA. 91710-7008. A Parts Return Authorization form is provided when **REED** deems its necessary to have the part returned for evaluation. The form is issued by the Warranty of Parts Department of **REED**.
 - A. The form will be filled by **REED** unless requesting necessary information and you will receive a copy as well as shipping tag.
 - B. Attach shipping tag to part insert return original invoice.
 - C. Ship part to **REED PREPAID**.
 - D. Part must be returned to **REED** within 30 days from date of authorization.

REED TRUCK MOUNTED CONCRETE BOOM PUMP MODEL **XXT 32**
ILLUSTRATED PARTS MANUAL GROUP 10 FINAL INSTALLATION CONTAINS
THE FOLLOWING FIGURES:

- FIGURE 00** TABLE OF CONTENTS
- FIGURE 01** FINAL INSTALLATION
- FIGURE 02** DECAL ASSEMBLY

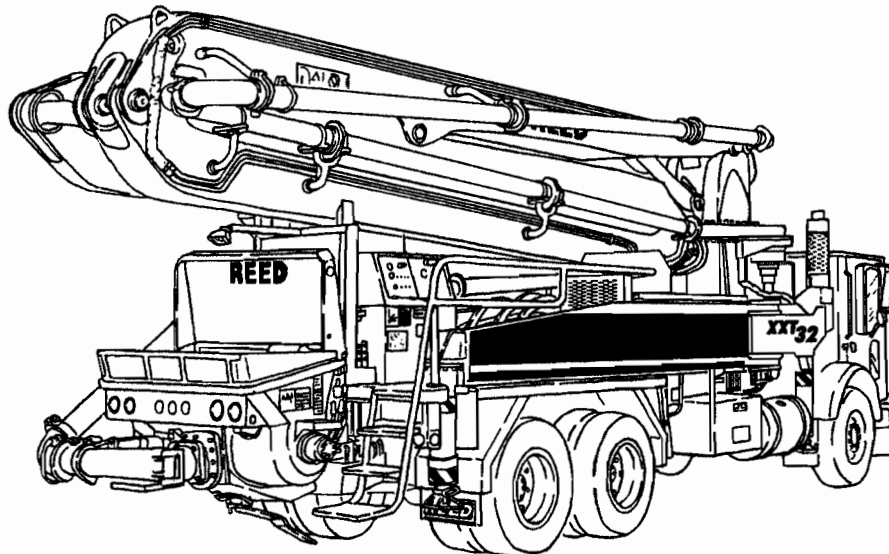

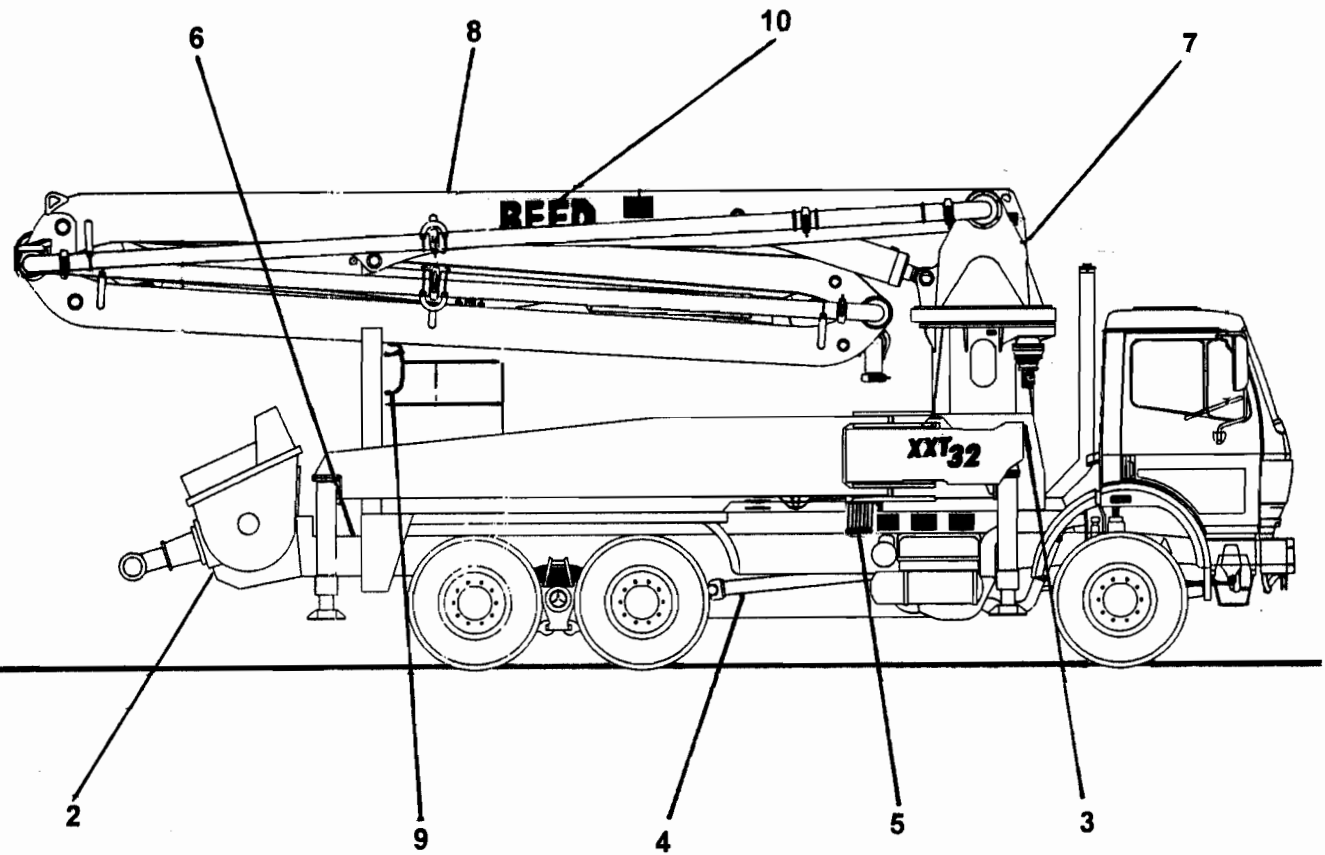

ITEM NO.	REED'S PARTS NO.	DESCRIPTION					QTY
		1	2	3	4	5	
-1	800519	Installation, XXT 32 Final					Ref
2	20-01	• Installation, Hopper (See Group 20, Figure 01 for DET)					1
3	30-01	• Installation, Tank (See Group 30, Figure 01 for DET)					1
4	40-01	• Installation, Power Train (Bef Jul 1999) (See Group 40, Figure 01 for DET)					1
	40-02	• Installation, Power Train (Aug 1999 ~ Mar 2000) (See Group 40, Figure 01 for DET)					1
	40-03	• Installation, Power Train (Apr 200 ~ Feb 2001) (See Group 40, Figure 01 for DET)					1
	40-04	• Installation, Power Train (Aft Mar 2001) (See Group 40, Figure 01 for DET)					1
5	50-01	• Installation, Control (Bef May 2000) (See Group 50, Figure 01 for DET)					1
	50-02	• Installation, Control (Aft Jun 2000) (See Group 50, Figure 01 for DET)					1
6	60-01	• Installation, Pumping Train (See Group 60, Figure 01 for DET)					1
7	70-01	• Installation, Frame and Support (See Group 70, Figure 01 for DET)					1
8	80-01	• Installation, Optional (See Group 80, Figure 01 for DET)					1
9	90-01	• Installation, Boom (See Group 90, Figure 01 for DET)					1
10	10-02	• Assembly, Decal (See Group 10, Figure 02 for DET)					1

DASH (-) ITEM NOT ILLUSTRATED

REED

DECAL ASSEMBLY

XXT 32
PARTS
GROUP 10
FIGURE 02
PAGE 01

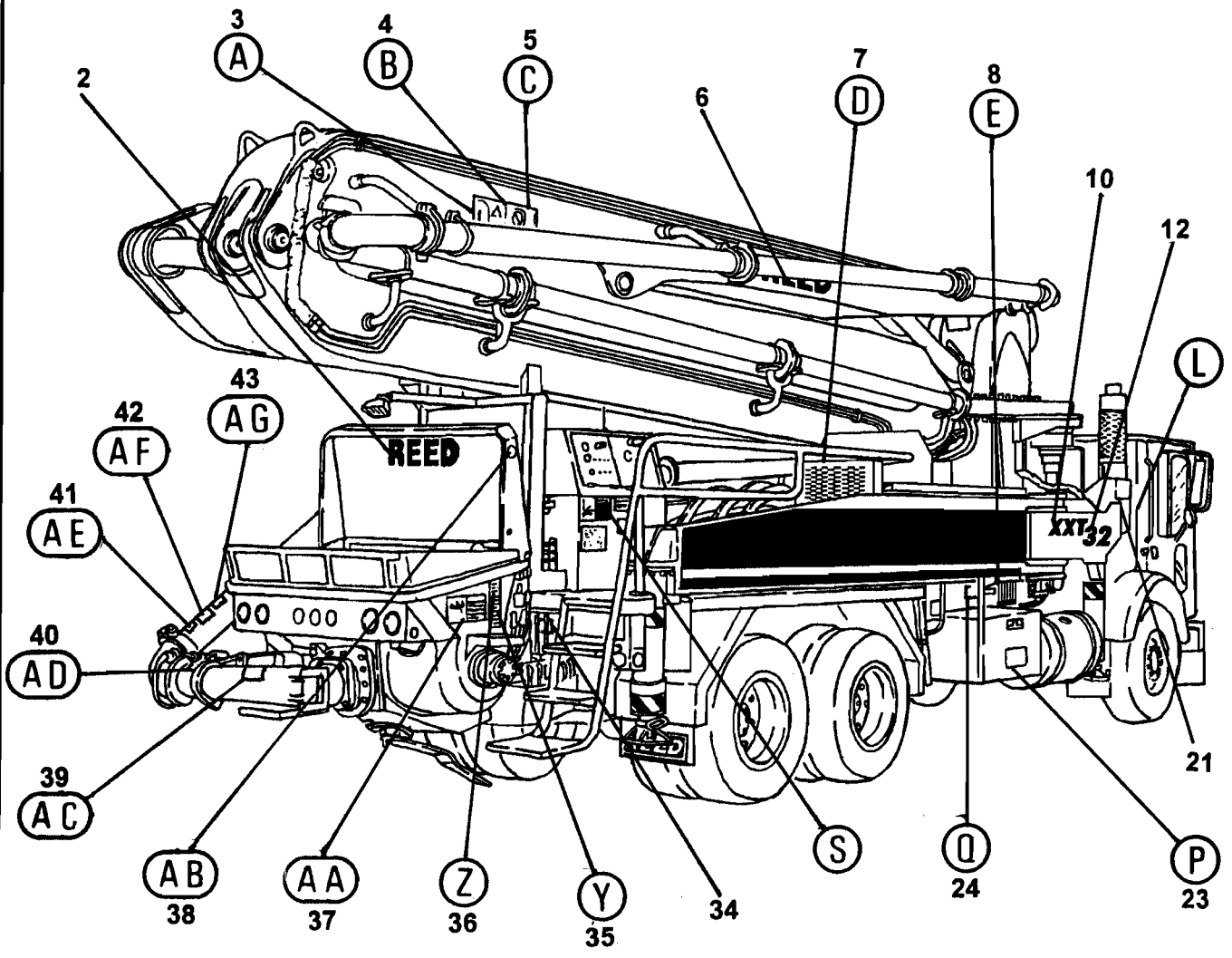
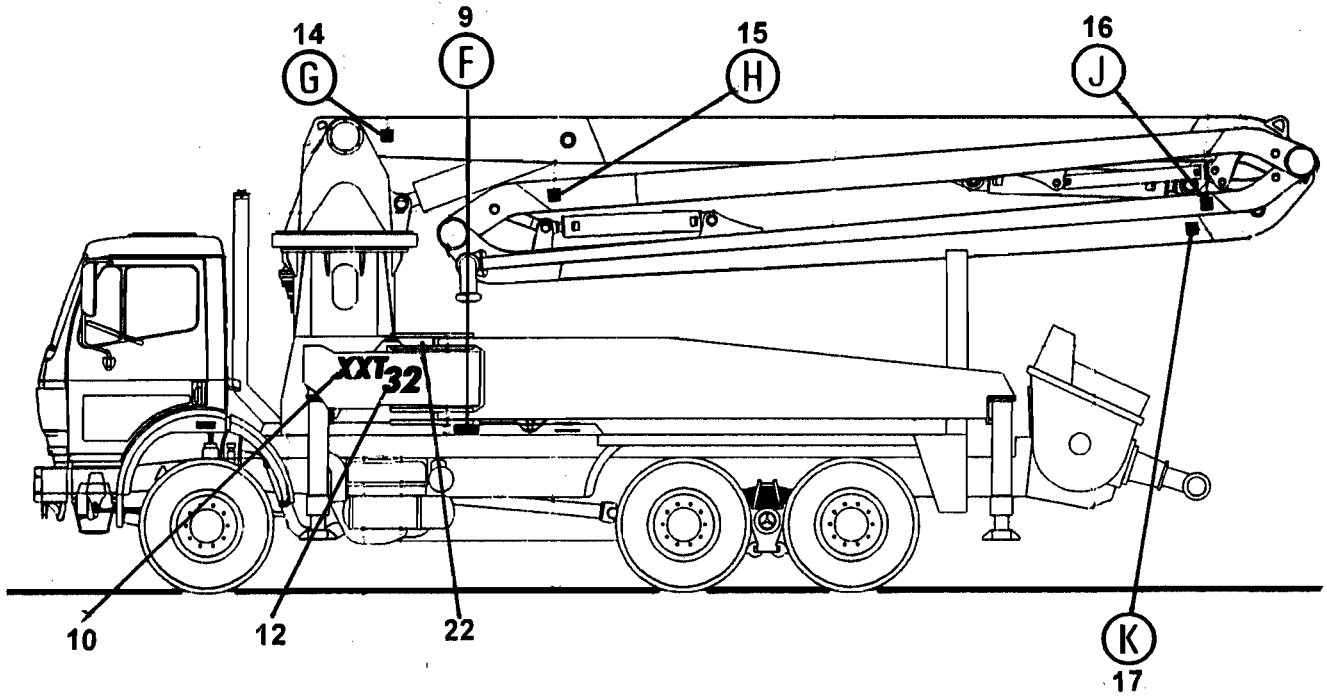

REVISION:

ITEM NO.	REED'S PARTS NO.	DESCRIPTION	QTY
-1	10-02	Assembly, Decal (See Group 10, Figure 01 for NHA)	Ref
2	800442	• Decal, REED , 6 Inch Black	1
3	C-4V107	• Plate, Danger Of Falling Object	1
4	C-4V106	• Plate, Never Use As Crane	1
5	C-4V105	• Plate, Death Hazard	1
6	801069	• Decal, REED , 12 Inch White	2
7	C-4V120	• Plate, Hydraulic Distributor	1
8	C-9V111	• Decal, Right Side Stabilizers	1
9	C-9V112	• Decal, Left Side Stabilizers	1
10	801068	• Decal, XXT , 5 Inch White	2
-11		• Decal, XXT , 5 Inch Optional Color	2
12	801070	• Decal, 32 , 8 Inch White	2
-13		• Decal, 32 , 8 Inch Optional Color	2
14	C-4V113	• Decal, A Letter Adhesive	1
15	C-4V115	• Decal, C Letter Adhesive	1
16	C-4V116	• Decal, D Letter Adhesive	1
17	C-4V114	• Decal, B Letter Adhesive	1
-18	800766	• Kit, XXT 32 Decal	1
19	800051	•• Nameplate, PTO	1
20	800059	•• Plate, PTO Operation	1
21	800034	•• Decal, Oil Level	2
22	800033	•• Decal, Water	1
23	800915	•• Decal, Danger, Stay Clear	1
24	800919	•• Decal, Warning, Stand Clear of Outriggers when activating	4
-25	800920	•• Decal, Warning, Clear Area Before Activating Outriggers	2
26	800439	•• Decal, Control Box Panel	1
27	801113	•• Decal, Gauge	1
28		•• Decal, A B	1
29	800926	•• Decal, Warning, Do Not Operate This Machine without	1
30	800929	•• Decal, Warning	1
31	800925	•• Decal, Warning, Do Not Operate This Machine without	1
32	800930	•• Decal, ACPA Hand Signals	1
33	800913	•• Decal, Danger, Electrocution Hazard	1
34	800875	•• Nameplate, Agitator / Water	1
35	800918	•• Decal, Warning, Do Not Stand on Hopper Grate	2
36	800917	•• Decal, Warning, Keep Hand Out of Hopper and Valve	2
37	800924	•• Decal, Warning, This Machine is Remote Controlled and	1
38	800931	•• Decal, ACPA Member	1
39	800922	•• Decal, Warning, Before Opening a Blocked Pipeline,	1
40	800923	•• Decal, Warning, Use Retaining Pins in all Delivery	1
41	800928	•• Decal, Warning, Total Weight of all Hanging Hoses,	1
42	800927	•• Decal, Warning, Do Not Use the Boom as a Crane	1
43	800921	•• Decal, Warning, Do Not Operate at Pressures Exceeding	1
-44	800914	•• Decal, Danger, Electrocution Hazard	1
-45	800916	•• Decal, Warning, Keep Hand Out of Water Box	1
46	75009	•• Nameplate, REED , Serial No.	1

DASH (-) ITEM NOT ILLUSTRATED

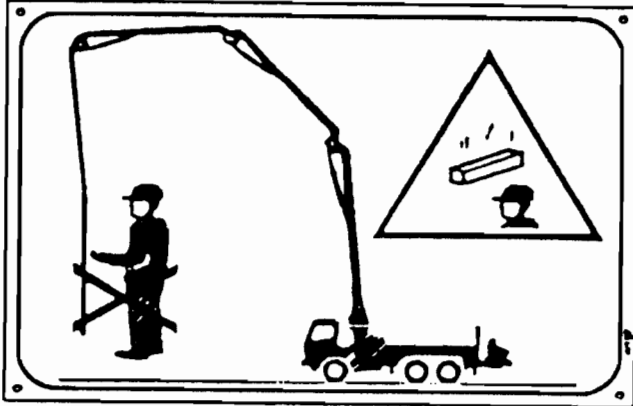

(A)

3

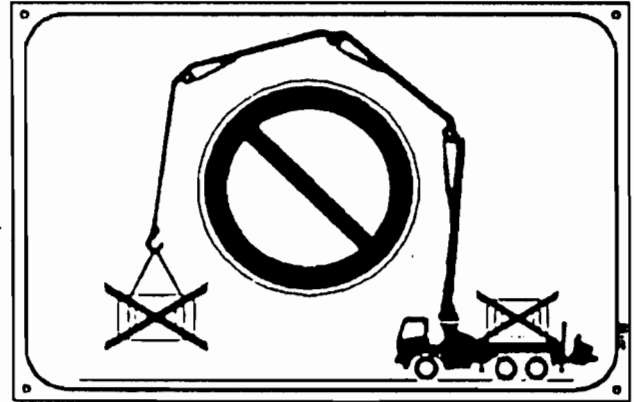

(B)

4

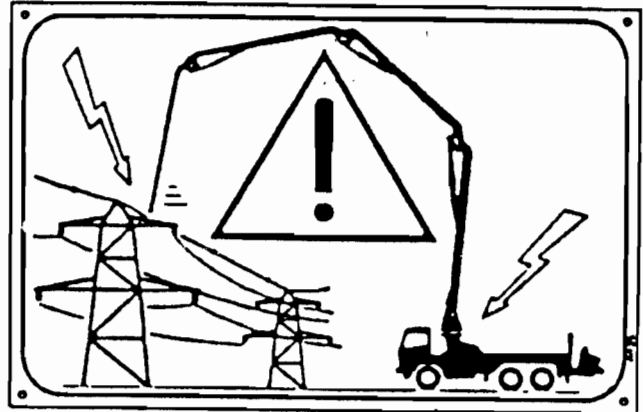

(C)

5

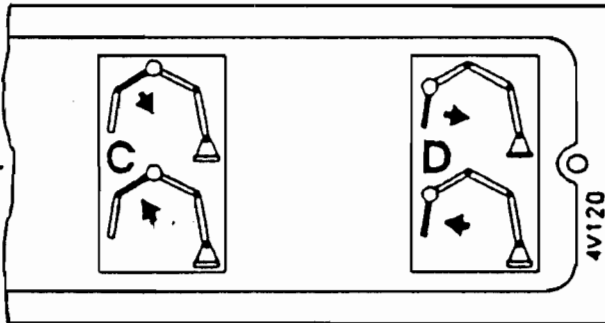

(D)

7

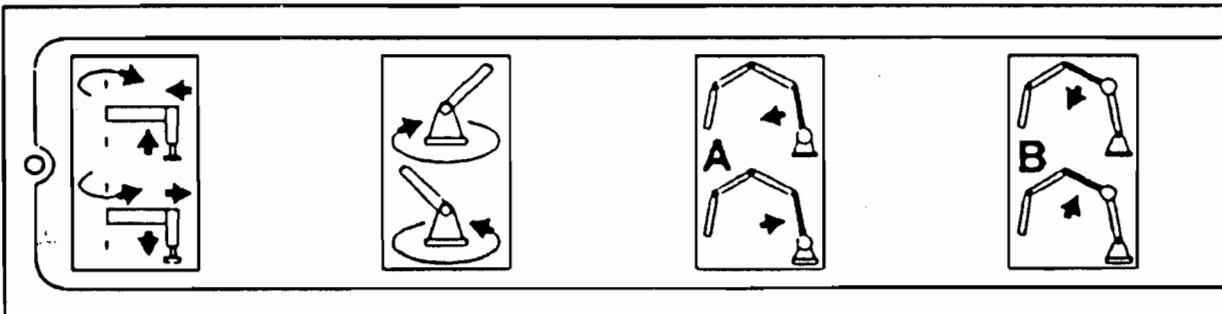

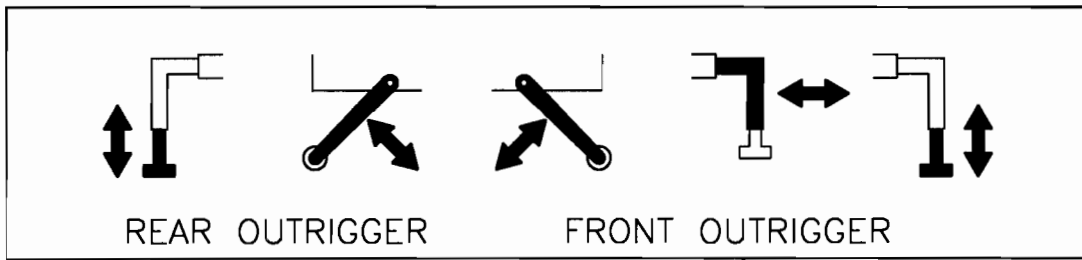

(E)

8

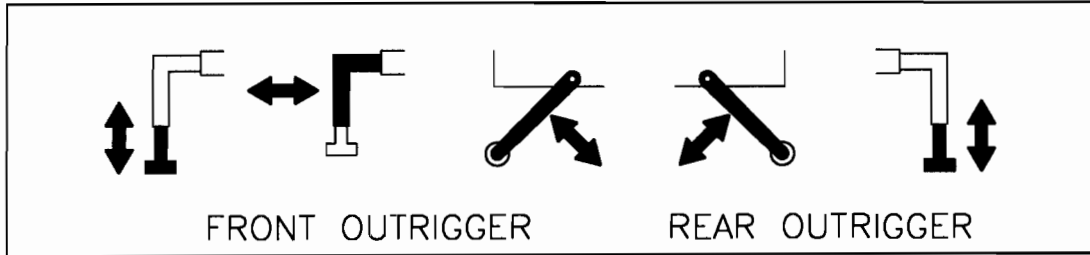

9

(F)

B

17

(K)

A

14

(G)

D

16

(J)

C

15

(H)

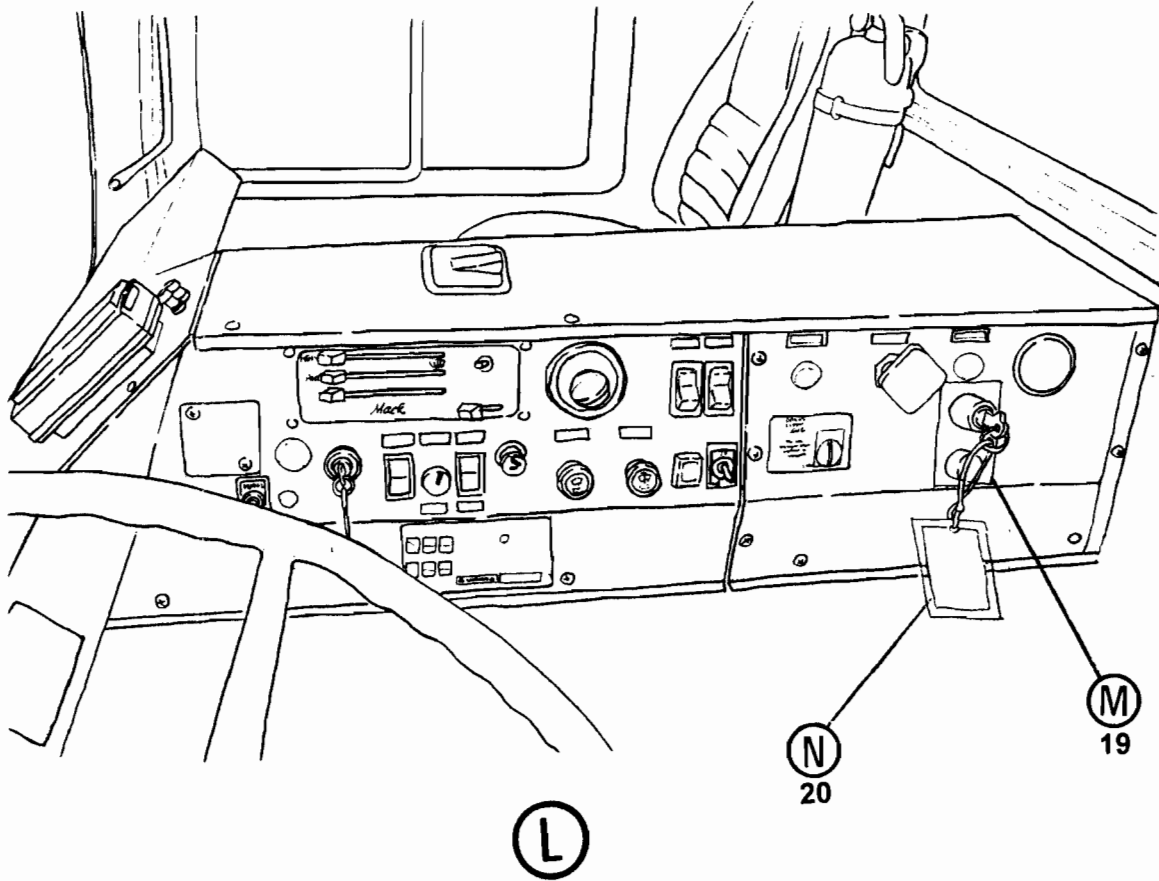

TO OPERATE PUMP AND BOOM

1. POSITION TRUCK AND SET PARKING BRAKE.
2. DEPRESS CLUTCH AND SHIFT TO 7TH GEAR HIGH.
3. TURN PTO ON.
4. RELEASE CLUTCH TO ENGAGE PUMPS.
5. SET THROTTLE AT 1600 RPM MAXIMUM.

TO RETURN TO DRIVING MODE

1. RETURN THROTTLE TO IDLE.
2. DEPRESS CLUTCH AND TURN PTO OFF.
3. SHIFT TO NUETRAL AND RELEASE CLUTCH.

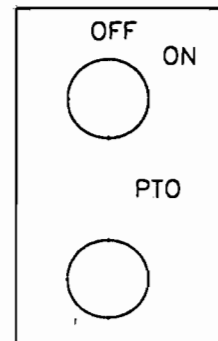

19

20

(N)

(M)



⚠ DANGER

Stay clear.
Contact will result in
death or serious injury
if the unit becomes
electrically charged.

800915

23

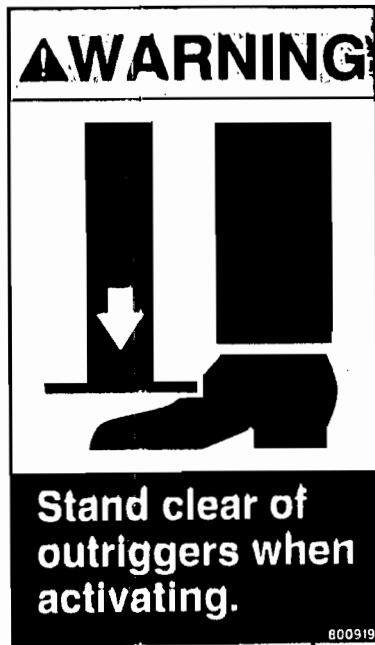

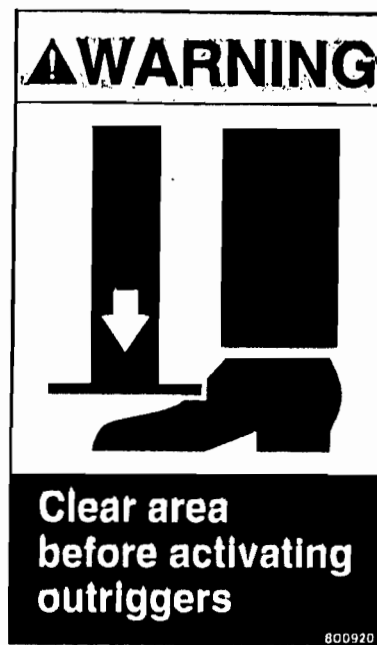

25



24

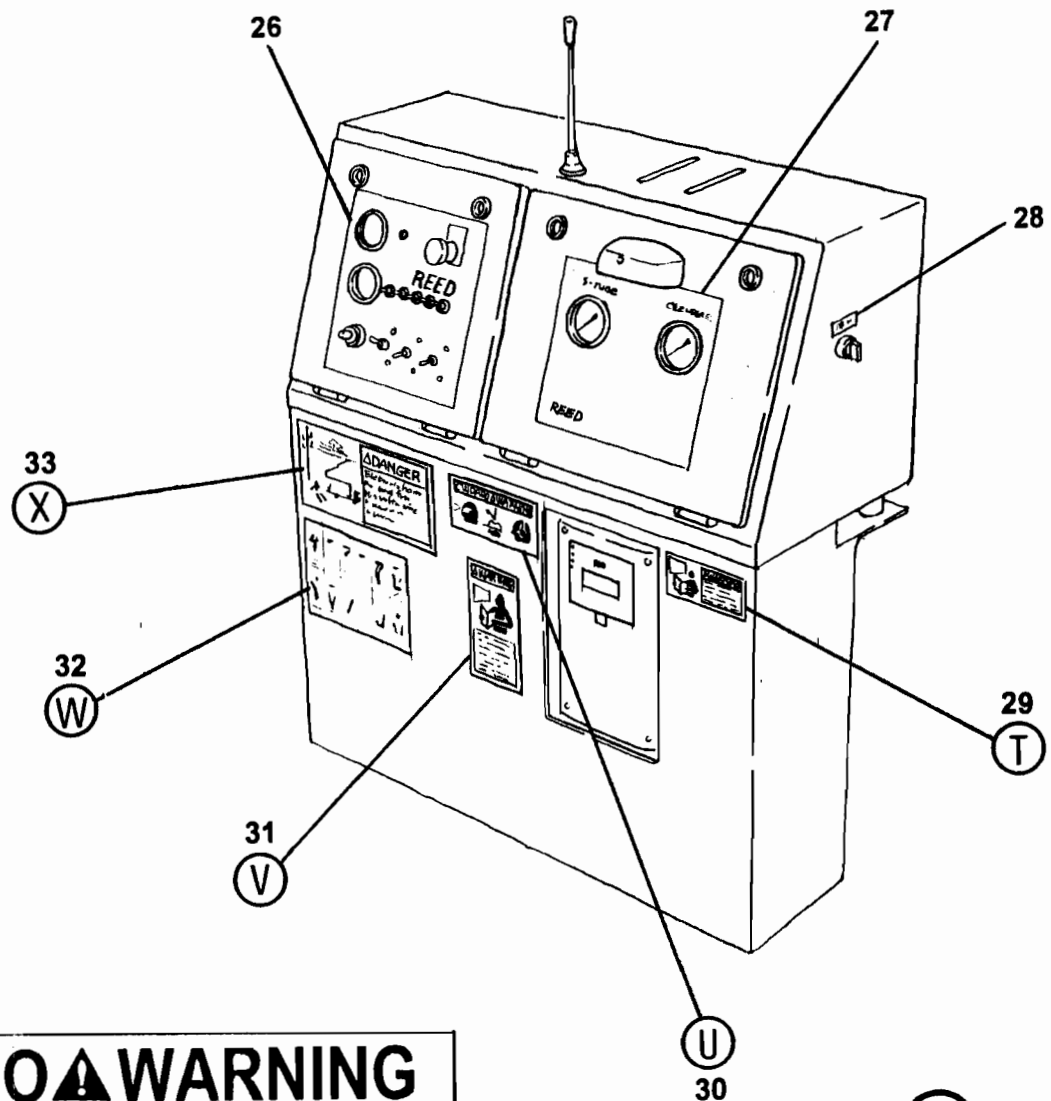

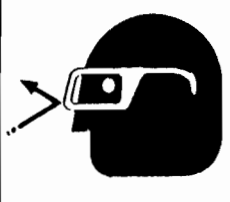
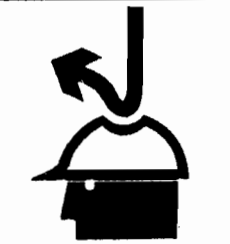

CUIDADO ⚠ WARNING		
		
<small>800929</small>		

U

30

29

T

	⚠ WARNING Do not operate this machine without training. Understand the warnings in safety manuals and on decals. <small>800928</small>
--	---

⚠ WARNING



Do not operate this machine without training. Understand the warnings in safety manuals and on decals.

800925

31



32



1. BOOM UP



2. BOOM DOWN



3. BOOM LEFT



4. BOOM RIGHT



5. OPEN OR EXTEND BOOM



6. CLOSE OR RETRACT BOOM



7. STOP BOOM



8. START PUMP SPEED UP



9. SLOW PUMP DOWN



10. STOP PUMP



11. LITTLE BIT



12. ADD WATER 4-GALLONS



13. ALL DONE CLEAN UP

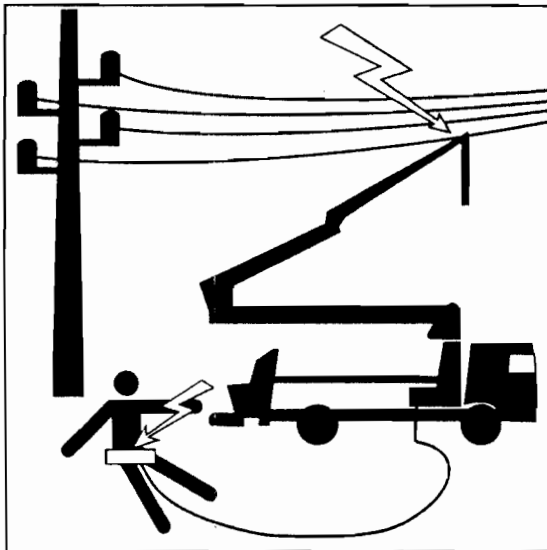

! DANGER

Electrocution hazard.
Stay back from
high voltage wires
at least 17 feet
(5 meters).

800913

(X)

33

! WARNING

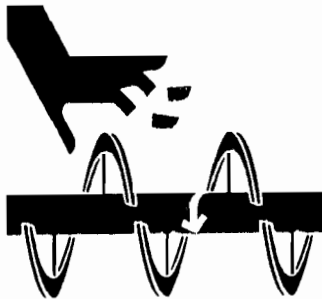

Keep hands out
of hopper and
valve assembly.
See operation
manual if access
is required.

800917

(Z)

36

! WARNING



Do not stand on
hopper grates.

800918

(Y)

35

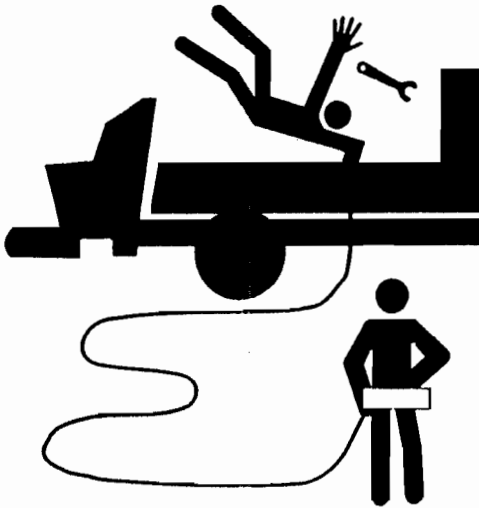

! WARNING

This machine is remote controlled and may start at any time. Stop engine before servicing unit.

800924

AA

37

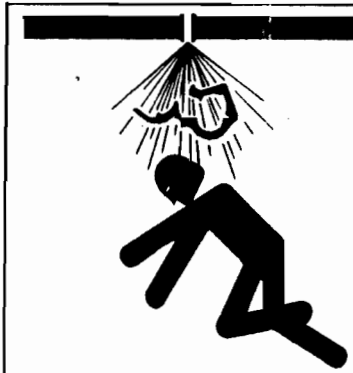

! WARNING

Use retaining pins in all delivery system snap clamps.

800923

AD

40



38

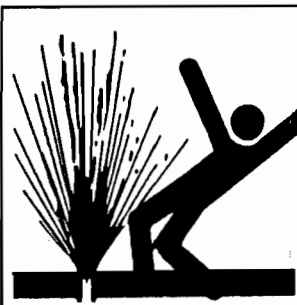

! WARNING

Before opening a blocked pipeline, relieve pressure by reversing pump. See manual.

800922

39

AC

AB

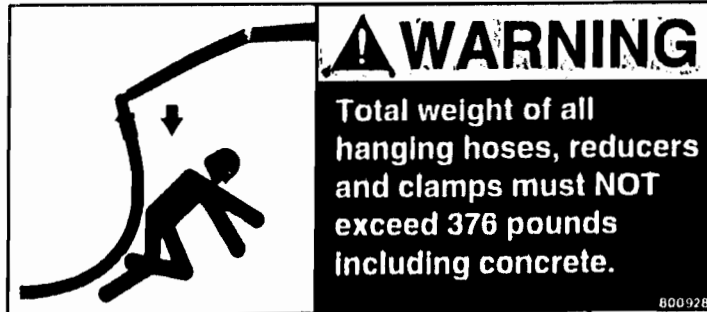

AE

41



AF

42



AG

43

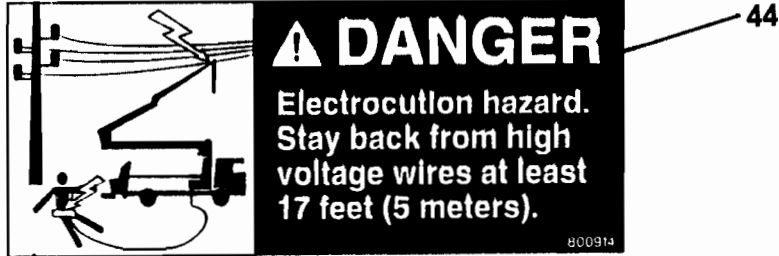

AH



AJ

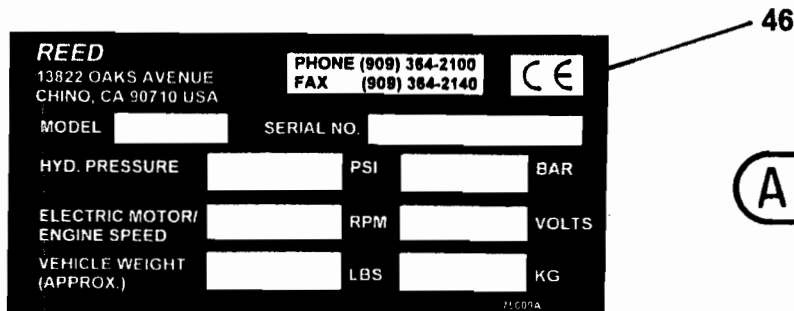

AK

ITEM NO.	REED'S PARTS NO.	DESCRIPTION					QTY
		1	2	3	4	5	
-1	10-02	Assembly, Decal (See Group 10, Figure 01 for NHA)					Ref
2	800442	• Decal, REED , 6 Inch Black					1
3	C-4V107	• Plate, Danger Of Falling Object					1
4	C-4V106	• Plate, Never Use As Crane					1
5	C-4V105	• Plate, Death Hazard					1
6	801069	• Decal, REED , 12 Inch White					2
7	C-4V120	• Plate, Hydraulic Distributor					1
8	C-9V111	• Decal, Right Side Stabilizers					1
9	C-9V112	• Decal, Left Side Stabilizers					1
10	801068	• Decal, XXT , 5 Inch White					2
-11		• Decal, XXT , 5 Inch Optional Color					2
12	801070	• Decal, 32 , 8 Inch White					2
-13		• Decal, 32 , 8 Inch Optional Color					2
14	C-4V113	• Decal, A Letter Adhesive					1
15	C-4V115	• Decal, C Letter Adhesive					1
16	C-4V116	• Decal, D Letter Adhesive					1
17	C-4V114	• Decal, B Letter Adhesive					1
-18	800766	• Kit, XXT 32 Decal					1
19	800051	•• Nameplate, PTO					1
20	800059	•• Plate, PTO Operation					1
21	800034	•• Decal, Oil Level					2
22	800033	•• Decal, Water					1
23	800915	•• Decal, Danger, Stay Clear					1
24	800919	•• Decal, Warning, Stand Clear of Outriggers when activating					4
-25	800920	•• Decal, Warning, Clear Area Before Activating Outriggers					2
26	800439	•• Decal, Control Box Panel					1
27	801113	•• Decal, Gauge					1
28		•• Decal, A B					1
29	800926	•• Decal, Warning, Do Not Operate This Machine without					1
30	800929	•• Decal, Warning					1
31	800925	•• Decal, Warning, Do Not Operate This Machine without					1
32	800930	•• Decal, ACPA Hand Signals					1
33	800913	•• Decal, Danger, Electrocutation Hazard					1
34	800875	•• Nameplate, Agitator / Water					1
35	800918	•• Decal, Warning, Do Not Stand on Hopper Grate					2
36	800917	•• Decal, Warning, Keep Hand Out of Hopper and Valve					2
37	800924	•• Decal, Warning, This Machine is Remote Controlled and					1
38	800931	•• Decal, ACPA Member					1
39	800922	•• Decal, Warning, Before Opening a Blocked Pipeline,					1
40	800923	•• Decal, Warning, Use Retaining Pins in all Delivery					1
41	800928	•• Decal, Warning, Total Weight of all Hanging Hoses,					1
42	800927	•• Decal, Warning, Do Not Use the Boom as a Crane					1
43	800921	•• Decal, Warning, Do Not Operate at Pressures Exceeding					1
-44	800914	•• Decal, Danger, Electrocutation Hazard					1
-45	800916	•• Decal, Warning, Keep Hand Out of Water Box					1
46	75009	•• Nameplate, REED , Serial No.					1

DASH (-) ITEM NOT ILLUSTRATED

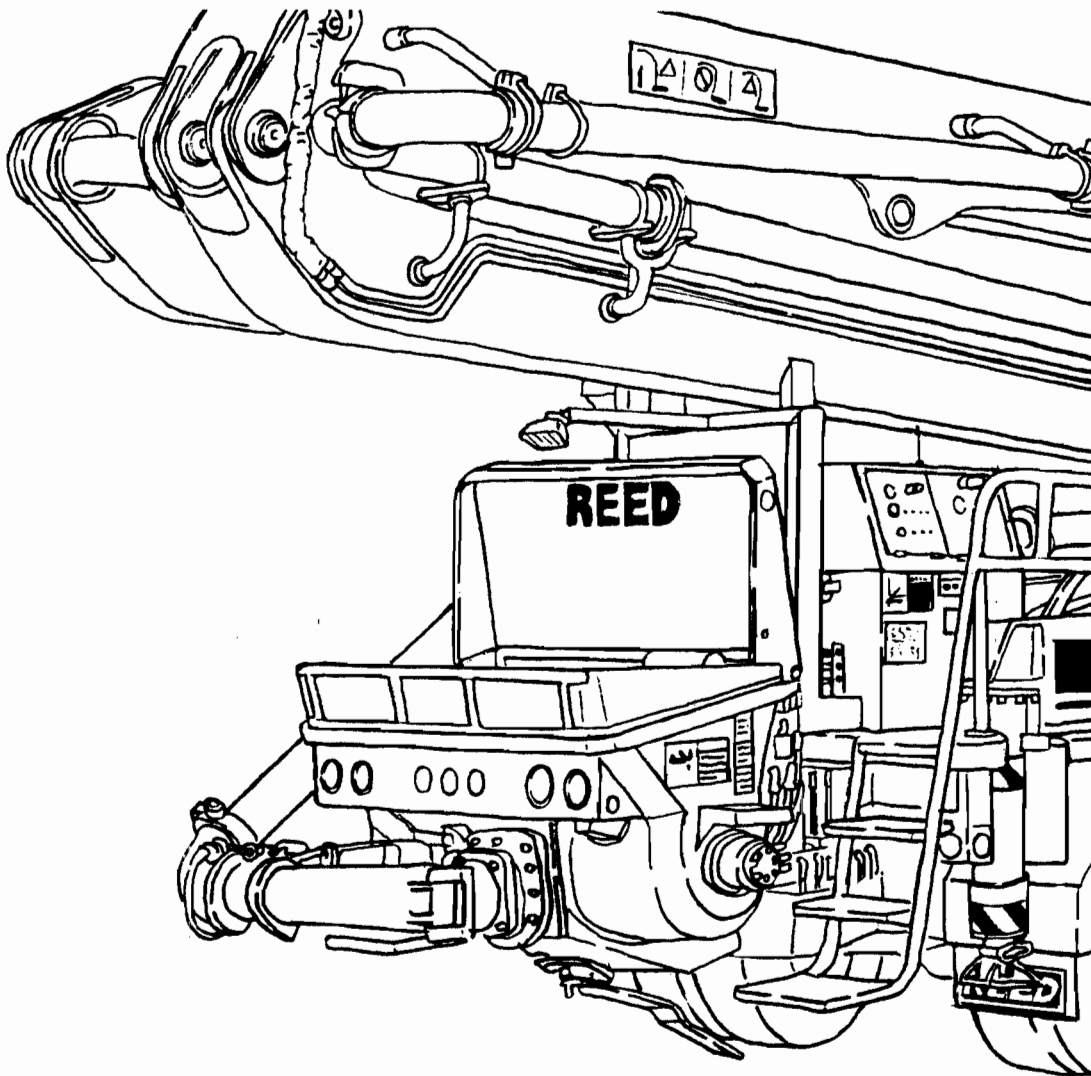

REED TRUCK MOUNTED CONCRETE BOOM PUMP MODEL XXT 32 ILLUSTRATED PARTS MANUAL GROUP 20 HOPPER INSTALLATION CONTAINS THE FOLLOWING FIGURES:

- | | |
|------------------|--------------------------------------|
| FIGURE 00 | TABLE OF CONTENTS |
| FIGURE 01 | HOPPER INSTALLATION |
| FIGURE 02 | LUBRICATION PUMP ASSEMBLY |
| FIGURE 03 | CENTRAL LUBRICATION SYSTEM |
| FIGURE 04 | HOPPER VIBRATION ASSEMBLY |
| FIGURE 05 | AGITATOR ASSEMBLY |
| FIGURE 06 | AGITATOR DRIVE MOTOR ASSEMBLY |
| FIGURE 07 | HOPPER OUTLET ASSEMBLY |

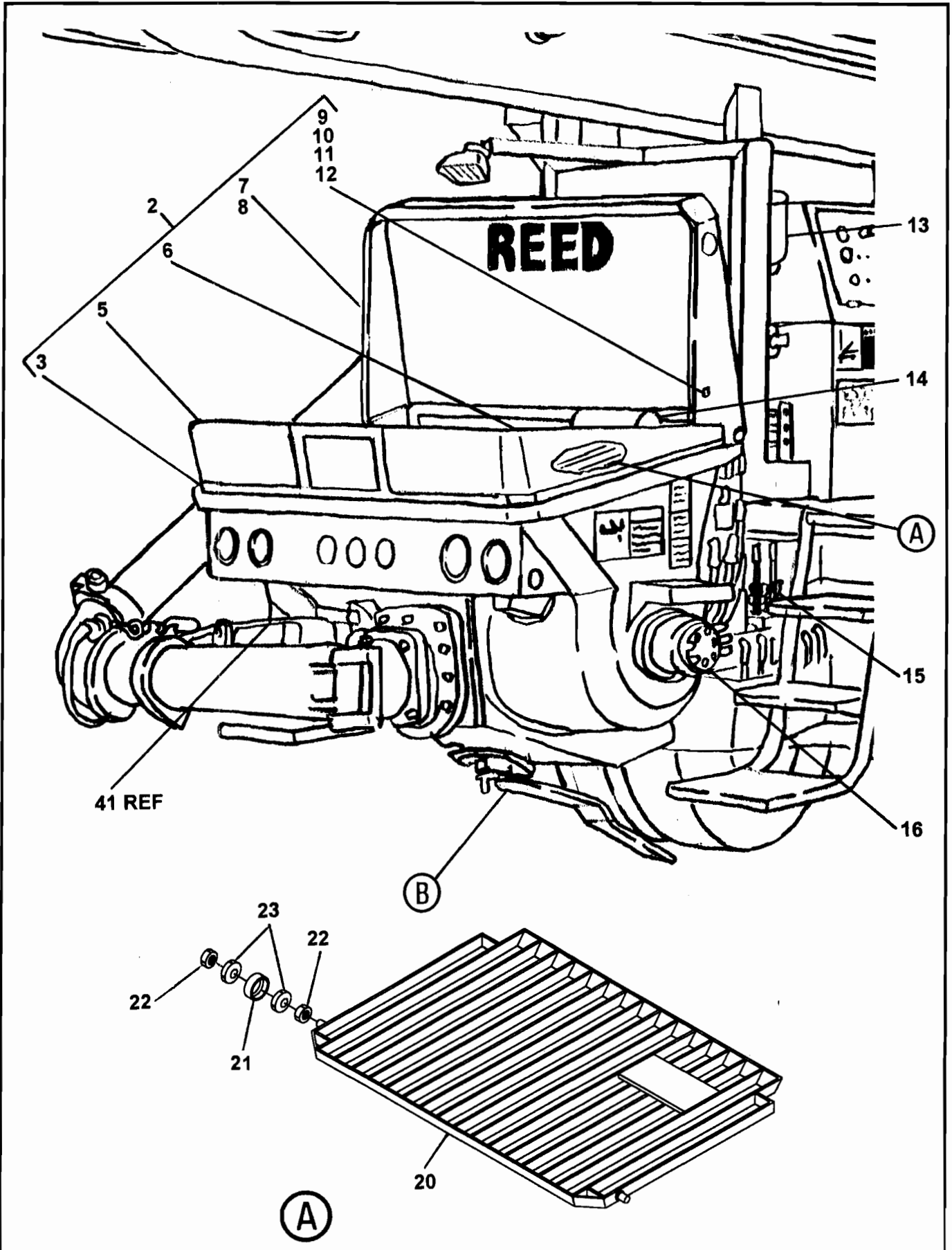

ITEM NO.	REED'S PARTS NO.	DESCRIPTION	QTY
-1	20-01	Installation, Hopper (See Group 10, Figure 01 for NHA)	Ref
2	800419	• Group, Splash Guard	1
3	800398	• • Bar, Splash Guard	1
-4	800402	• • Strip, Silicon 0.53	1
5	800399	• • Rubber Flap, Splash Guard	1
6	800416	• • Rubber, Splash Guard 10 FT	1
7	79056	• • Handle, Splash Guard	1
8	800395	• • Weldment, Splash Guard	1
9	800400	• • Pivot plate, Splash Guard	2
10	800401	• • Plunger, Spring	2
11	800417	• • Pin	1
12	800418	• • Lanyard	1
13	B-183000	• Assembly, Central Lubrication System (See Group 20, Figure 02 for DET)	1
14	71429	• Assembly, Hopper Vibration (See Group 20, Figure 04 for DET)	1
15	W-100124	• Assembly, Agitator/Wash Control Valve	1
-16	B-254120	• Assembly, Agitator (See Group 20, Figure 05 for DET)	1
-17	W-104067	• Buffer, Grid Rubber	4
-18	W-101559	• Washer (attaching parts)	4
19	W-101847	• Nut, Cap (attaching parts)	8
20	B-224035	• Grid	1
21	W101849	• Buffer, Rubber	2
22	W-101559	• Washer	4
23	B-223011	• Nut, Cap	4

DASH (-) ITEM NOT ILLUSTRATED



HOPPER INSTALLATION

XXT 32
PARTS
GROUP 20
FIGURE 01
PAGE 03

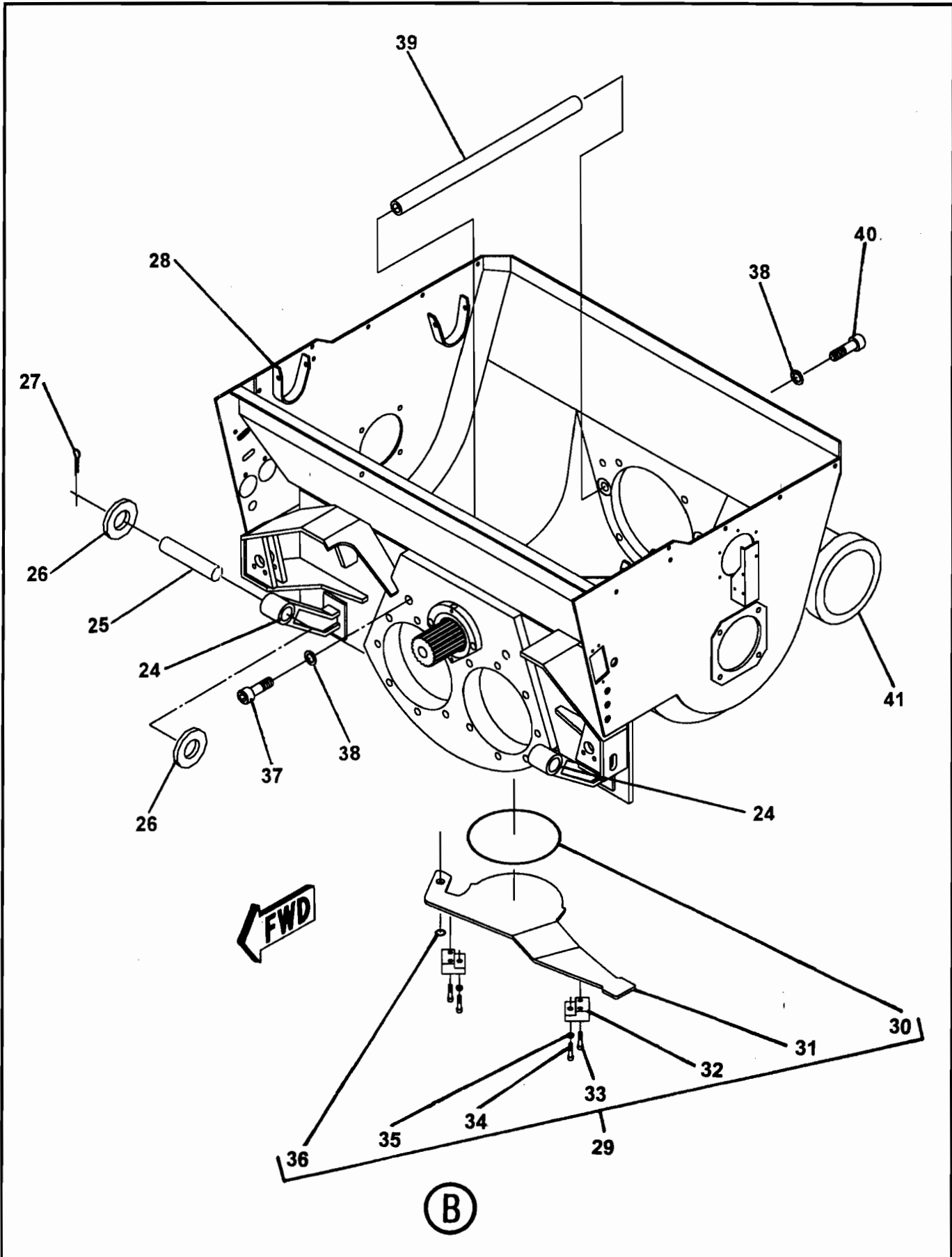

REVISION:

ITEM NO.	REED'S PARTS NO.	DESCRIPTION					QTY
		1	2	3	4	5	
24	W-102489	• Buffer, Rubber					2
25	W-100940	• Pin					2
26	W-103411	• Washer					4
27		• Pin, Cotter					4
28	B-173021	• Weldment, Hopper					1
29	B-173085	• Assembly, Cleaning Cover					1
30	W-102908	• • O-Ring, Round Cord					1
31	B-172130	• • Cover, Cleaning					1
32	B-172126	• • Block, Clamping					2
33	W-102855	• • Screw, M20 (attaching parts)					4
34	B-172218	• • Screw, M20 (attaching parts)					2
35	W-102891	• • Nut, Hex M20 (attaching parts)					2
36	W-102864	• • Ring, Lock					1
37	W-103074	• Screw, Hex					2
38	W-102331	• Washer					4
39	B-174075	• Rod, Tie					2
40	W-103073	• Screw, Hex M24					2
41	20-07	• Assembly, Hopper Outlet (See Group 20, Figure 07 for DET)					1

DASH (-) ITEM NOT ILLUSTRATED

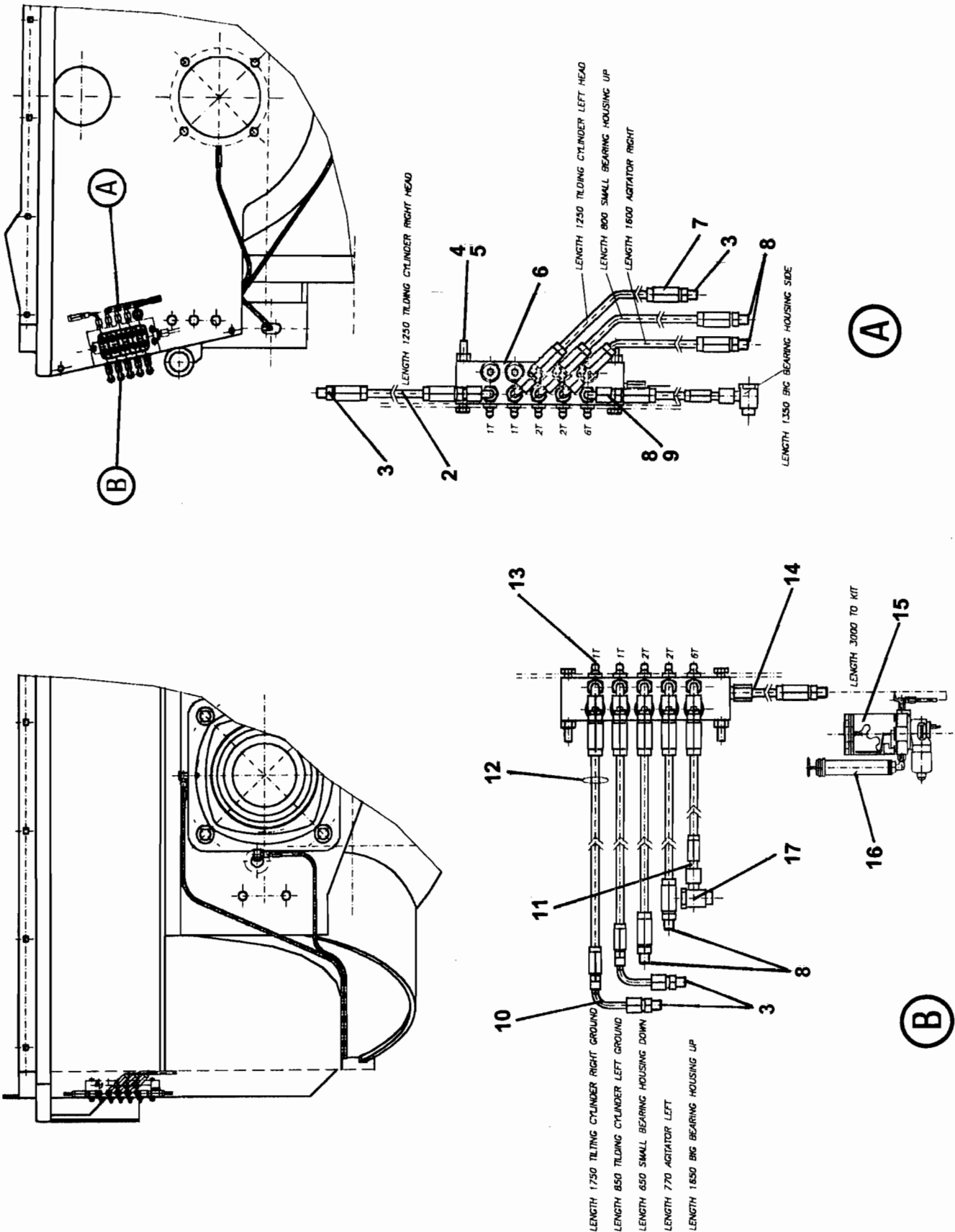



CENTRAL LUBRICATION SYSTEM

XXT 32
PARTS
GROUP 20
FIGURE 02
PAGE 02

ITEM NO.	REED'S PARTS NO.	DESCRIPTION					QTY
		1	2	3	4	5	
-1	B-183000	System, Central Lubrication (See Group 20, Figure 01 for NHA)					Ref
2	W-100255	• Pipe, Plastic					1
3	W-102603	• Coupling, Straight Male Stud					4
4	W-103512	• Screw, Hex					3
5	W-102131	• Nut, Lock					3
6	W-102602	• Distributor, Lubrication					1
7	W-100254	• Sleeve, Threaded					22
8	W-100548	• Coupling, Straight Male Stud					5
9	W-102664	• Elbow, Adjustable					10
10	W-100643	• Sleeve, Threaded					2
11	W-100253	• Piece, Hose Connection					20
12	W-103137	• Tie, Cable					30
13	W-100303	• Nipple, Grease					10
14	W-102665	• Coupling, Straight Male Stud					1
15	800065	• Assembly, Lubrication Pump (See Group 20, Figure 03 for DET)					1
16	78532	• Gun, Grease					1
17	W-102884	• Elbow, Throttle Free benjo					2

DASH (-) ITEM NOT ILLUSTRATED

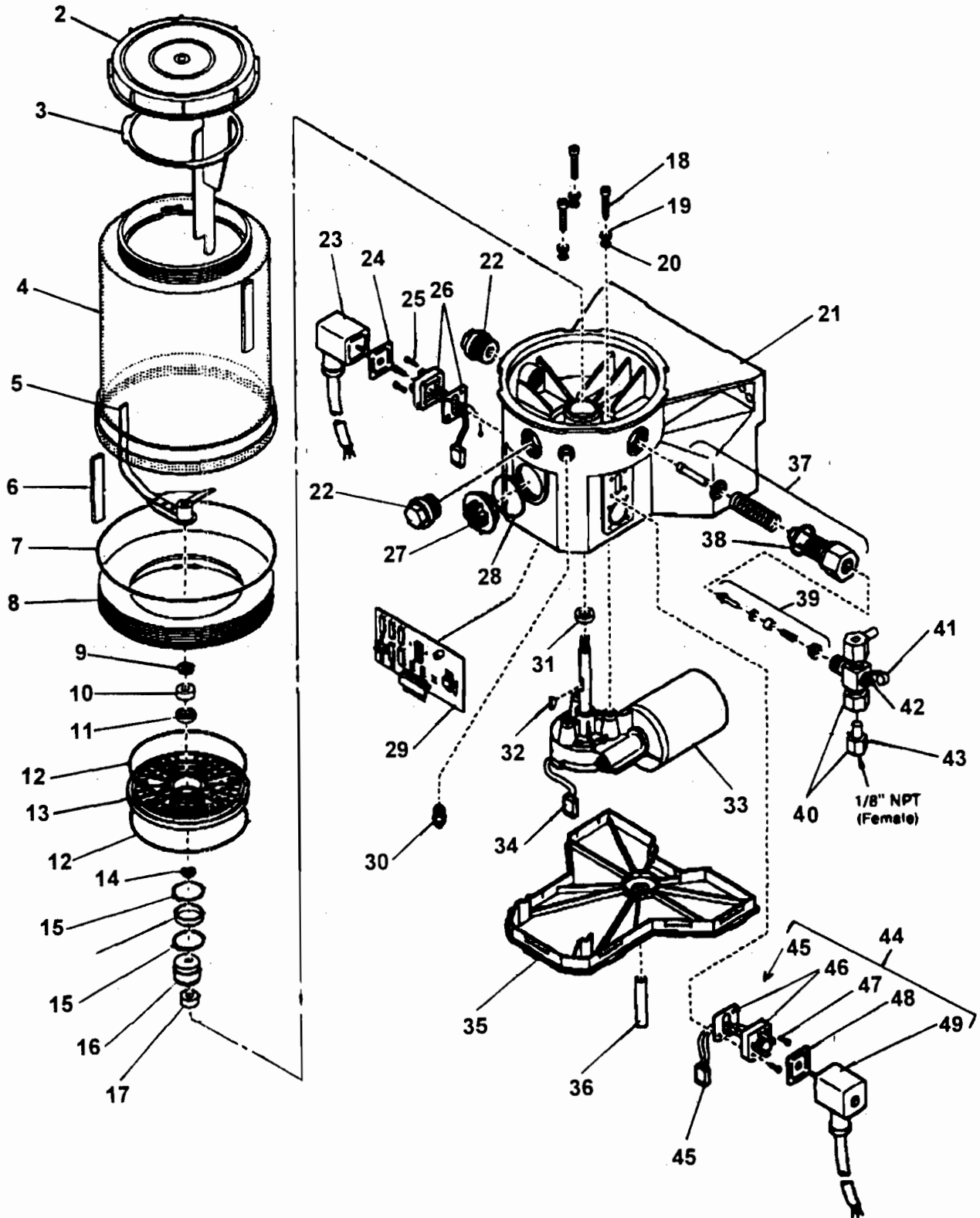

ITEM NO.	REED'S PARTS NO.	DESCRIPTION					QTY
		1	2	3	4	5	
-1	800065	Assembly, Lubrication Pump (See Group 20, Figure 02 for NHA)					Ref
2		• Lid					1
3		• Paddle, Fixed					1
4		• Reservoir					1
5		• Paddle, Stirring					1
6		• Hose					1
7		• O-Ring					1
8		• Adapter					1
9		• Washer					1
10		• Ring, Bearing					2
11		• Bearing					1
12		• O-Ring					2
13		• Plate, Intermediate					1
14		• Shim					1
15		• Ring, Snap					2
16		• Ring, Inner					1
17		• Cam, Eccentric					1
18		• Screw					3
19		• Washer					3
20		• O-Ring					3
21		• Housing, Pump					1
22		• Plug, Closure					2
23		• Socket with Cord					1
24		• Packing, Flat					1
25		• Screw					4
26		• Plug					1
27		• Plug, Sealing					1
28		• O-Ring					1
29		• Board, Printed Circuit					1
30		• Fitting, Grease					1
31		• Seal, Radial					1
32		• Key, Wood Ruff					1
33		• Motor, 12 VDC					1
34		• Plug, Motor					1
35		• Cover, Housing					1

DASH (-) ITEM NOT ILLUSTRATED

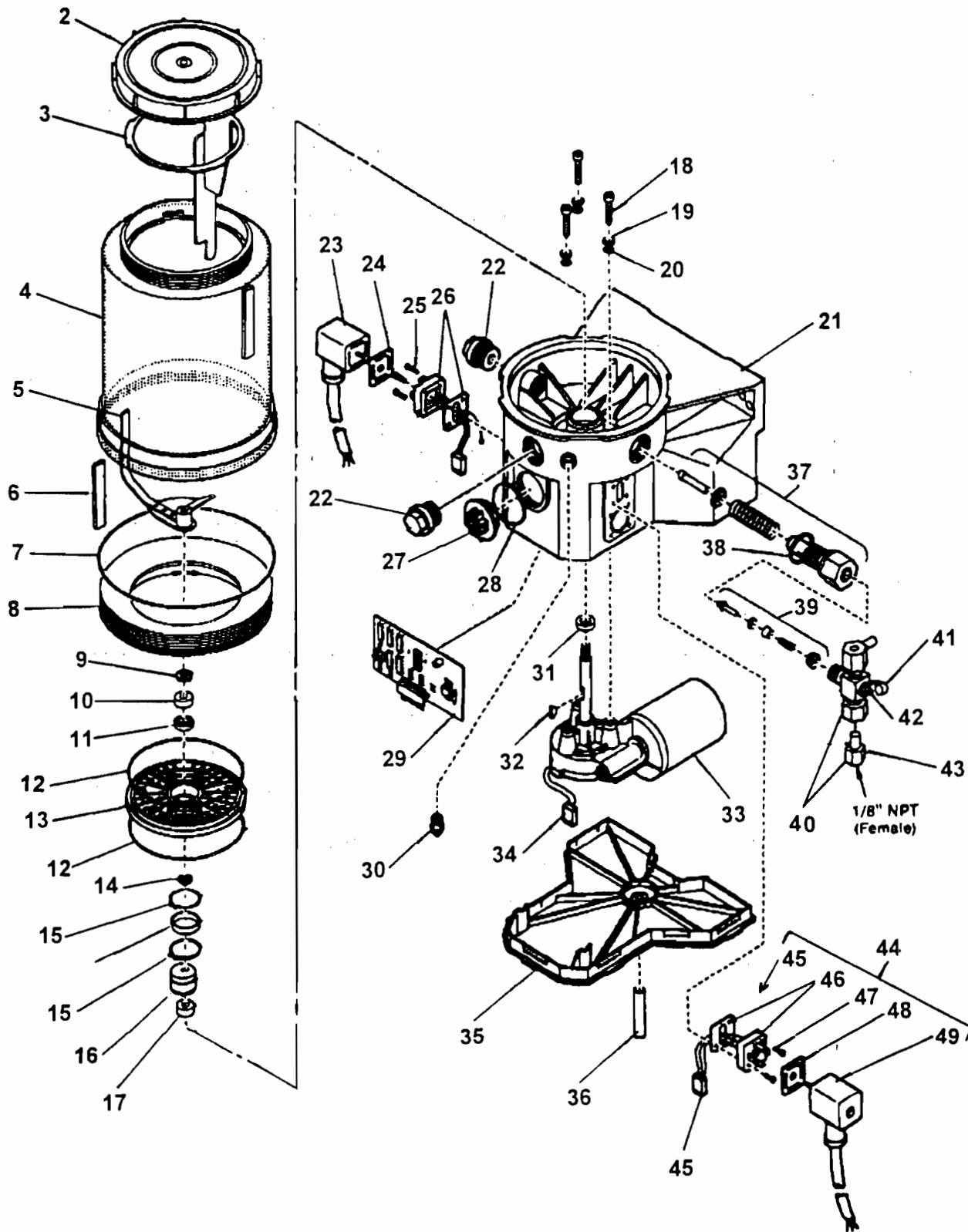



LUBRICATION PUMP ASSEMBLY

XXT 32
PARTS
GROUP 20
FIGURE 03
PAGE 04

ITEM NO.	REED'S PARTS NO.	DESCRIPTION					QTY
		1	2	3	4	5	
36		•	Hose				1
37		•	Element, Pump				1
38		•	Gasket				1
39		•	Valve, Check				1
40		•	Assembly, Pressure Release				1
41		•	Cap, Grease				1
42		•	Fitting, Grease				1
43		•	Adapter for Relief				1
44		•	Assembly, Optional Pressure Relief Valve				1
45		• •	Cord, Optional Power				1
46		• •	Plug, Optional				1
47		• •	Screw, Optional				4
48		• •	Packing, Optional Flat				1
49		• •	Socket, Optional				1

DASH (-) ITEM NOT ILLUSTRATED

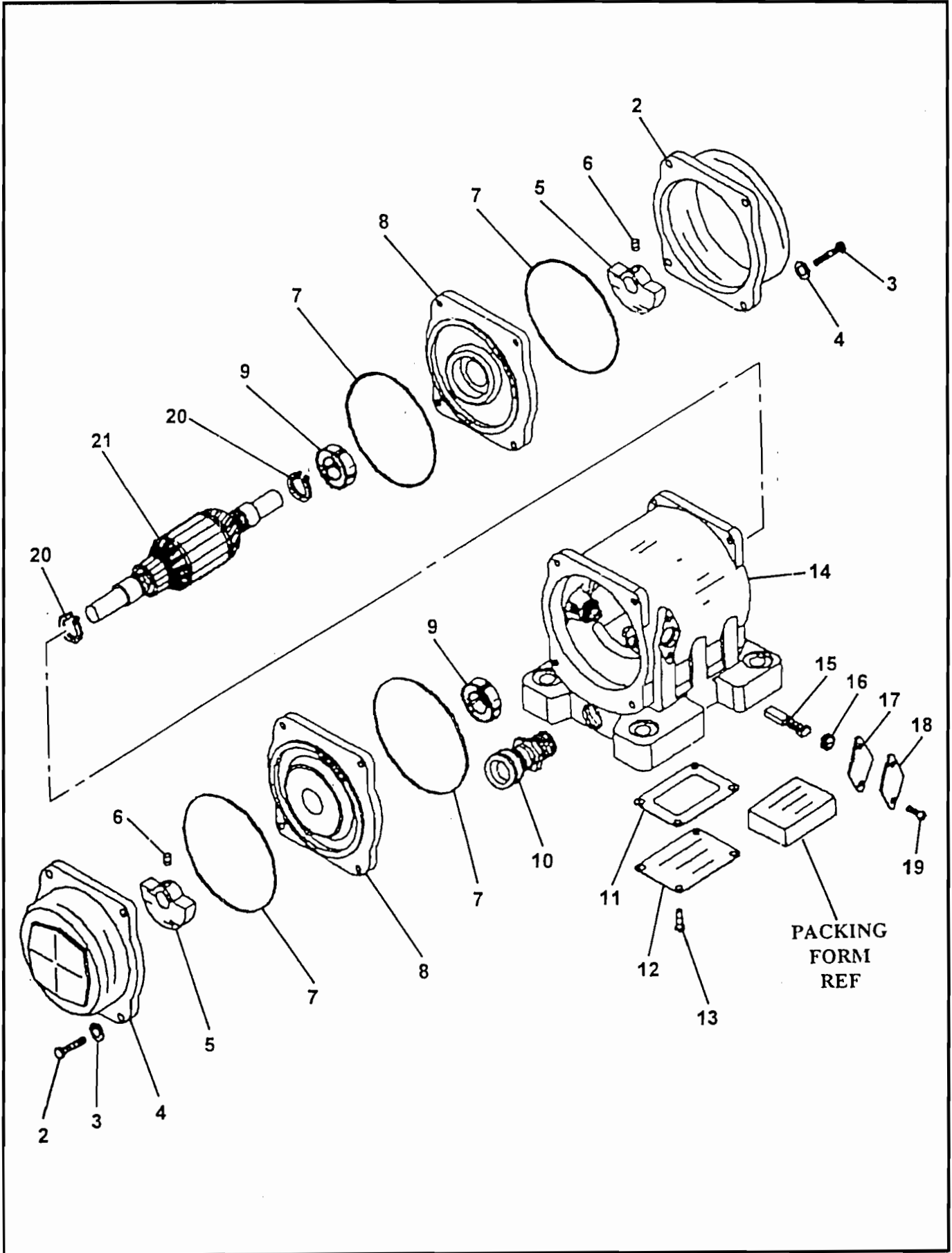

ITEM NO.	REED'S PARTS NO.	DESCRIPTION					QTY
		1	2	3	4	5	
-1	71429	Assembly, Hopper Vibrator (See Group 20, Figure 01 for NHA)					Ref
2		• Cap, End					2
3		• Bolt (attaching parts)					8
4		• Washer, Lock (attaching parts)					8
5		• Weight					2
6		• Screw, Set (attaching parts)					2
7		• O-Ring					4
8		• Bell, End					2
9		• Bearing					2
10		• Holder, Cord					1
11		• Gasket					1
12		• Cover, Box					1
13		• Screw (attaching parts)					4
14		• Sub-Assembly, Housing					1
15		• Brush					1
16		• Cap, Brush					2
17		• Gasket					2
18		• Cover, Brush					2
19		• Screw (attaching parts)					4
20		• Ring, Snap					2
21		• Assembly, Armature					1

DASH (-) ITEM NOT ILLUSTRATED

AGITATOR ASSEMBLY

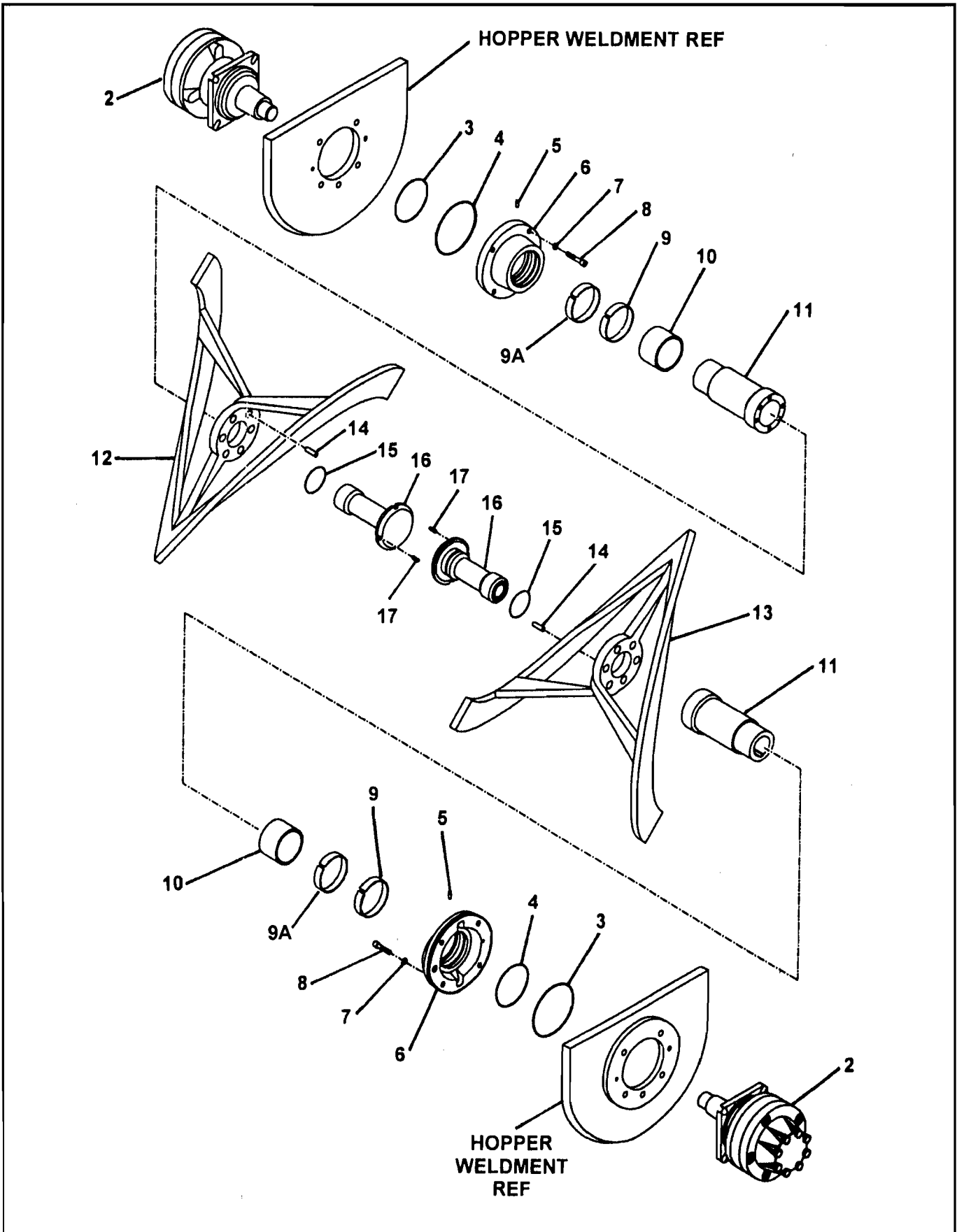

ITEM NO.	REED'S PARTS NO.	DESCRIPTION					QTY
		1	2	3	4	5	
-1	B-254120	Assembly, Agitator (See Group 20, Figure 01 for NHA)					Ref
2	W-101240	• Assembly, Agitator Drive Motor (See Group 20, Figure 08 for DET)					1
3	W-103064	• O-Ring					2
4	W-103063	• O-Ring					2
5	W-1004909	• Screw, M5 Set					2
6	B-254101	• Assembly, Flange					2
7	W-102962	• Washer					8
8	W-103062	• Screw, M12 Hex					8
9	W-102544	• Ring, Groove-Outer					2
9A	B-253029	• Ring, Groove-Inner					2
10	B-254104	• Sleeve, Wear					2
11	B-254102	• Shaft					2
12	B-254105	• Agitator, Left					1
13	B-254106	• Agitator, Right					1
14	W-103065	• Pin 10m					12
15	W-103249	• O-Ring					2
16	B-254103	• Nut					2
17	W-103106	• Sleeve, Clamping					4

DASH (-) ITEM NOT ILLUSTRATED



AGITATOR DRIVE MOTOR ASSEMBLY

XXT 32
PARTS
GROUP 20
FIGURE 06
PAGE 01

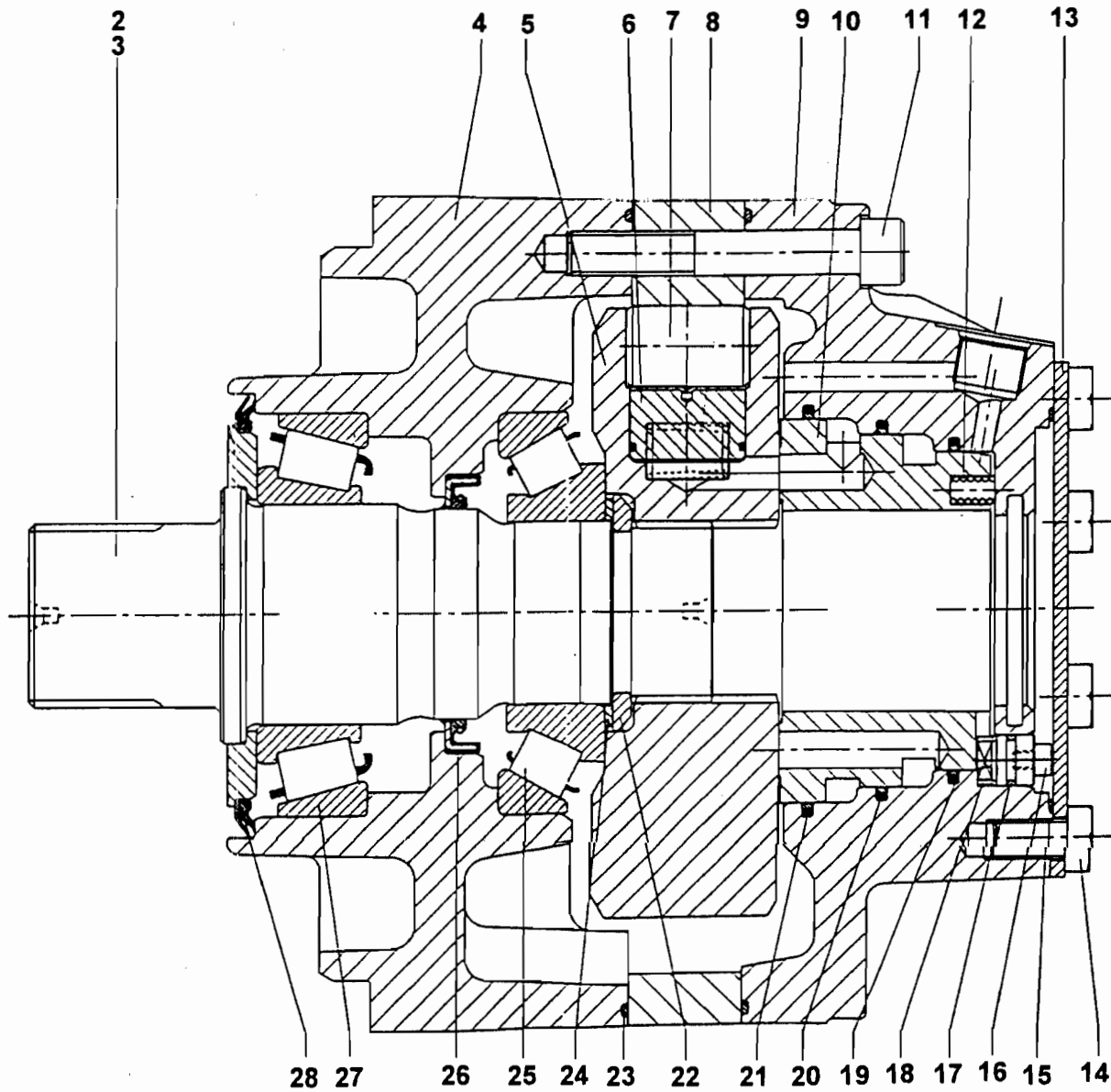

REVISION:

ITEM NO.	REED'S PARTS NO.	DESCRIPTION					QTY
		1	2	3	4	5	
-1	W-101240	Assembly, Agitator Drive Motor (See Group 20, Figure 05 for NHA)					Ref
2		• Assembly, Auger Drive Motor					1
3		• Shaft					1
4		• Case, Front					1
5		• Block, Cylinder					1
6		• Piston					8
7		• Roller					8
8		• Cam					1
9		• Case, Rear					1
10		• Ring, Distributor					1
11		• Screw, Cap M12					12
12		• Spring					6
13		• Plate, Cover					1
14		• Screw, Hex M10					8
15		• O-Ring					1
16		• Screw, Cap M5					1
17		• O-Ring					1
18		• Pin, Stop					1
19		• Seal, Rod					1
20		• Seal, Rod					1
21		• Seal, Rod					1
22		• Ring, Split					1
23		• O-Ring					2
24		• Washer					1
25		• Bearing					1
26		• Seal, Shaft					1
27		• Bearing					1
28		• Seal, Face					1

DASH (-) ITEM NOT ILLUSTRATED

CONCRETE DECK PIPE LINE ASSEMBLY
(SEE GROUP 90, FIGURE 10 FOR REF)

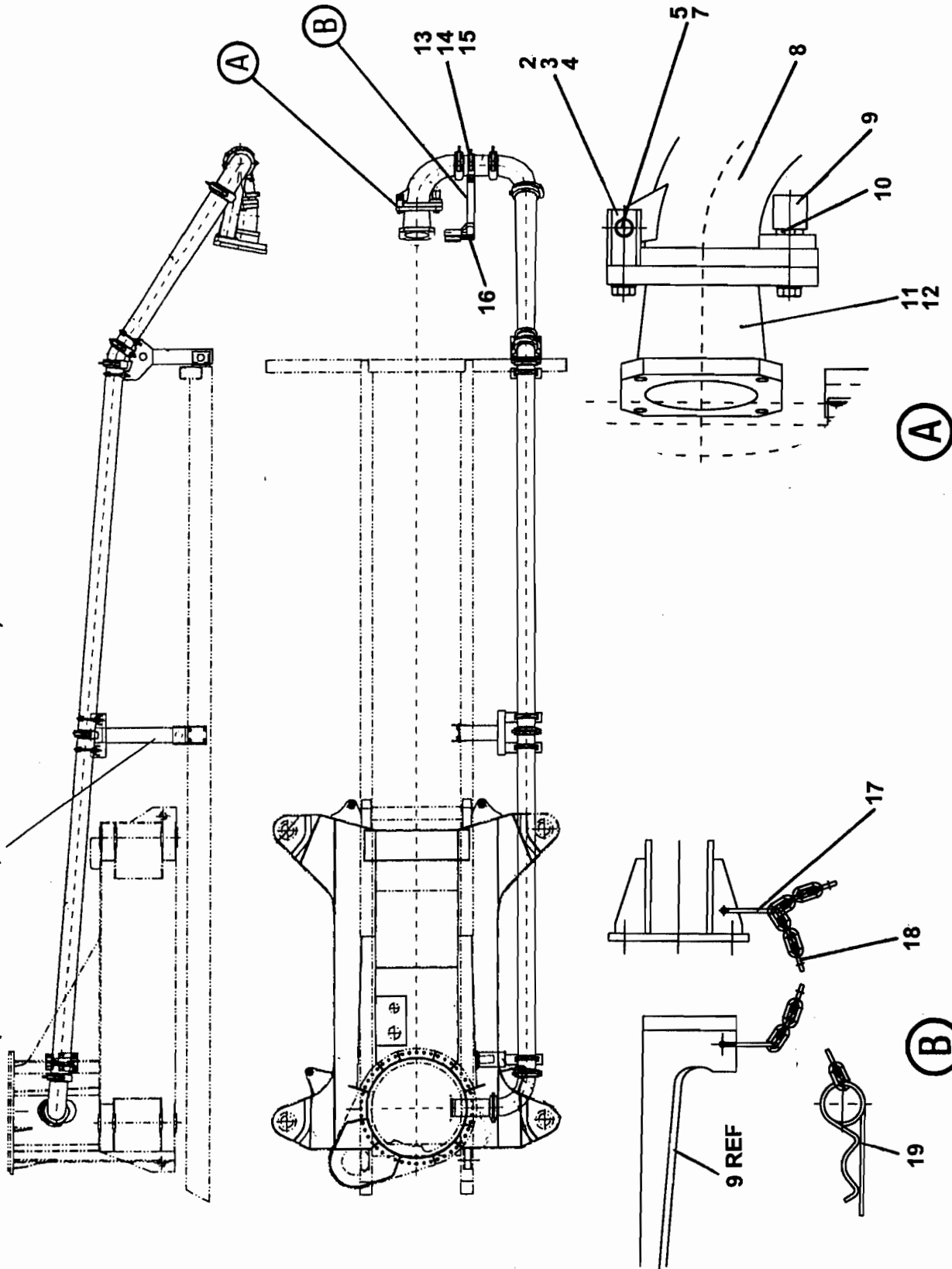

ITEM NO.	REED'S PARTS NO.	DESCRIPTION					QTY
		1	2	3	4	5	
-1	20-07	Assembly, Hopper Outlet (See Group 20, Figure 01 for NHA)					Ref
2	B-194049	• Hinge					2
3	W-102848	• Screw, M24 Hex Head					3
4	W-102331	• Washer					3
5	W-100694	• Ring, Snap					2
-6	B-194065	• Sub- Assembly, Hopper Outlet					1
7	B-194050	• • Bolt					1
8	B-191015	• • Elbow, Reducer					1
9	B-194046	• • Wedge, Locking					1
10	B-194045	• • Bolt, Locking					1
11	B-191010	• • Reducer					1
12	W-104025	• • O-Ring, Hopper Elbow					1
13	W-101779	• • Coupling, 6 Inch Clamp					3
14	W-100690	• • Elbow, 6 Inch					1
15	W-101545	• • O-Ring					3
16	B-194053	• • Coupling, Delivery Line Snap					1
17	W-103731	• S-Hook					2
18	W-103732	• Chain					1
19	W-103733	• Pin, Spring					1

DASH (-) ITEM NOT ILLUSTRATED

REED

**MODEL XXT 32 TRUCK MOUNTED
CONCRETE BOOM PUMP
ILLUSTRATED PARTS MANUAL**

**XXT 32
PARTS
GROUP 20
FIGURE 08
PAGE 01**

THIS PAGE INTENTIONALLY LEFT BLANK.

REED TRUCK MOUNTED CONCRETE BOOM PUMP MODEL **XXT 32** ILLUSTRATED PARTS MANUAL GROUP 30 HYDRAULIC TANK INSTALLATION CONTAINS THE FOLLOWING FIGURES:

- FIGURE 00** TABLE OF CONTENTS
- FIGURE 01** TANK INSTALLATION
- FIGURE 02** WATER SYSTEM GROUP
- FIGURE 03** WASH WATER PUMP ASSEMBLY
- FIGURE 04** WATER PUMP MOTOR ASSEMBLY

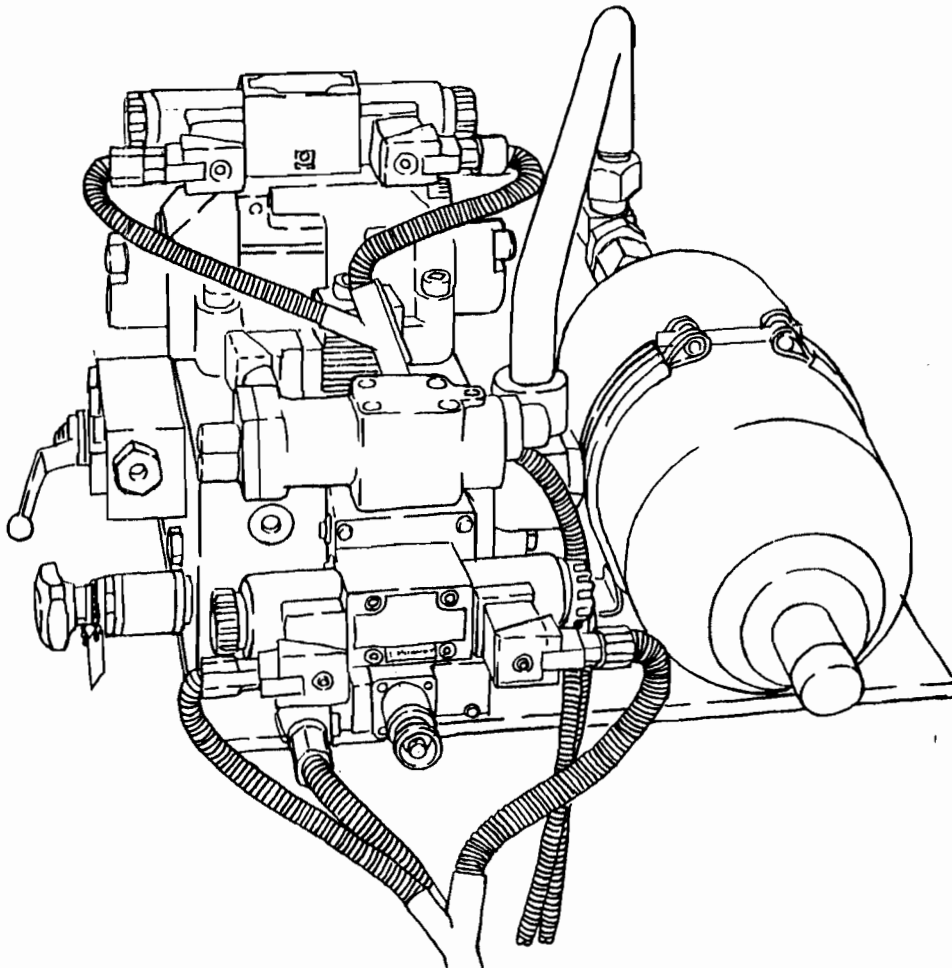

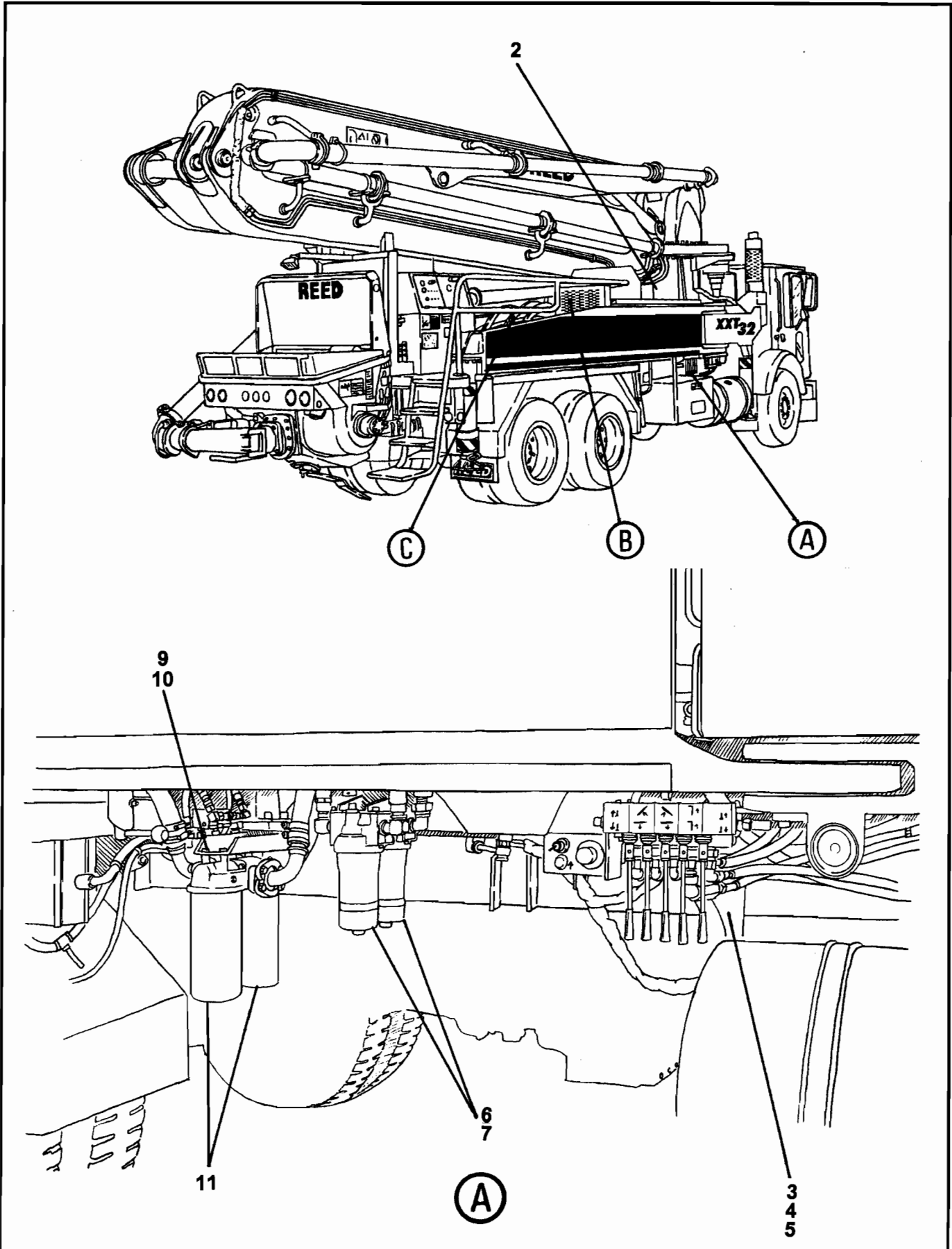

ITEM NO.	REED'S PARTS NO.	DESCRIPTION					QTY
		1	2	3	4	5	
-1	30-01	Installation, Tank (See Group 10, Figure 01 for NHA)					Ref
-2	800750	• Group, Water System (See Group 30, Figure 02 for DET)					1
3	W-105526	• Assembly, Boom High Pressure Filter					1
4	W-105527	• • Element, Boom High Pressure Filter					1
5	W-105556	• Indicator, Boom High Pressure Filter Visual Clogging					1
6	73300	• Assembly, Hydraulic Filter					2
7	73303	• • Element, Hydraulic Filter					1
8	800651	• Assembly, Hydraulic Oil Cooler					1
9	79276	• Gauge, Return Filter Indicator					2
10	79245	• Assembly, Return Filter					1
11	79269	• • Element, Return Filter					2
12	W-104847	• Assembly, Swing Tube Manifold					1
13	W-105573	• Assembly, Swing Tube Circuit Solenoid Valve					1
14	W-105581	• • Pilot, Solenoid Valve					1
15	W-105576	• • • Coil, Swing Tube Circuit Solenoid Valve					2
16	W-105572	• Cartridge, Solenoid Valve					1
17	W-105605	• • Coil					1
18	W-105579	• Valve, HP Limiter					1
19	W-103616	• Accumulator					1
20	71460	• Kit, Accumulator Charge (Optional Item) (See Group 80, Figure 02 for REF)					1
21	73171	• Bracket, Accumulator					A/R
22	W-105582	• Valve, Proportional Pilot					1
23	W-105606	• • Coil					1
24	W-105581	• Assembly, Pump Control Solenoid Valve					1
25	W-105576	• • Coil, Pump Control Solenoid Valve					2
26	W-104846	• Assembly, Pump Control Manifold					1
27	W-105570	• Cartridge, Relief Valve					1
28	W-105577	• Cartridge, Check Valve					1
29	W-105578	• Valve, Ball					1

DASH (-) ITEM NOT ILLUSTRATED

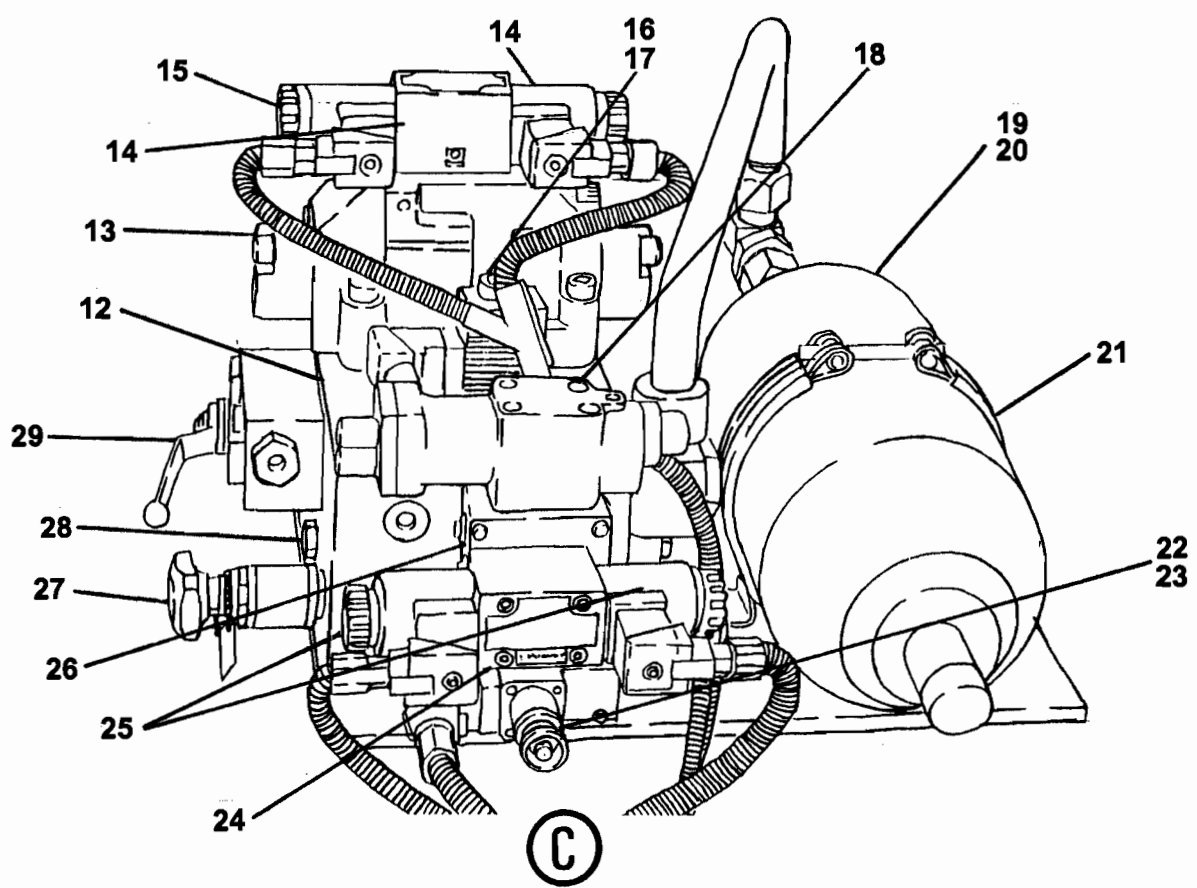
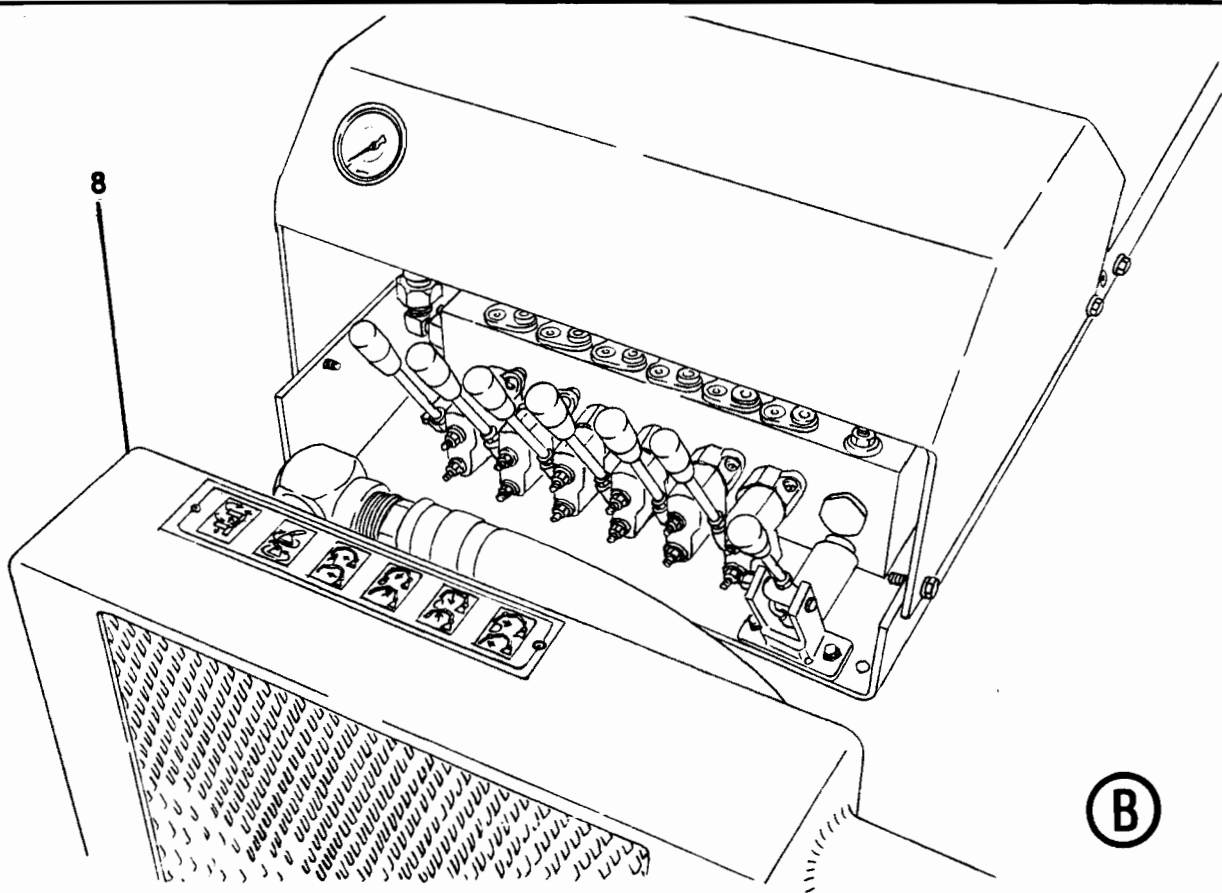

ITEM NO.	REED'S PARTS NO.	DESCRIPTION					QTY
		1	2	3	4	5	
-1	30-01	Installation, Tank (See Group 10, Figure 01 for NHA)					Ref
-2	800750	• Group, Water System (See Group 30, Figure 02 for DET)					1
3	W-105526	• Assembly, Boom High Pressure Filter					1
4	W-105527	• • Element, Boom High Pressure Filter					1
5	W-105556	• Indicator, Boom High Pressure Filter Visual Clogging					1
6	73300	• Assembly, Hydraulic Filter					2
7	73303	• • Element, Hydraulic Filter					1
8	800651	• Assembly, Hydraulic Oil Cooler					1
9	79276	• Gauge, Return Filter Indicator					2
10	79245	• Assembly, Return Filter					1
11	79269	• • Element, Return Filter					2
12	W-104847	• Assembly, Swing Tube Manifold					1
13	W-105573	• Assembly, Swing Tube Circuit Solenoid Valve					1
14	W-105581	• • Pilot, Solenoid Valve					1
15	W-105576	• • • Coil, Swing Tube Circuit Solenoid Valve					2
16	W-105572	• Cartridge, Solenoid Valve					1
17	W-105605	• • Coil					1
18	W-105579	• Valve, HP Limiter					1
19	W-103616	• Accumulator					1
20	71460	• Kit, Accumulator Charge (Optional Item) (See Group 80, Figure 02 for REF)					1
21	73171	• Bracket, Accumulator					A/R
22	W-105582	• Valve, Proportional Pilot					1
23	W-105606	• • Coil					1
24	W-105581	• Assembly, Pump Control Solenoid Valve					1
25	W-105576	• • Coil, Pump Control Solenoid Valve					2
26	W-104846	• Assembly, Pump Control Manifold					1
27	W-105570	• Cartridge, Relief Valve					1
28	W-105577	• Cartridge, Check Valve					1
29	W-105578	• Valve, Ball					1

DASH (-) ITEM NOT ILLUSTRATED



WATER SYSTEM GROUP

XXT 32
PARTS
GROUP 30
FIGURE 02
PAGE 01

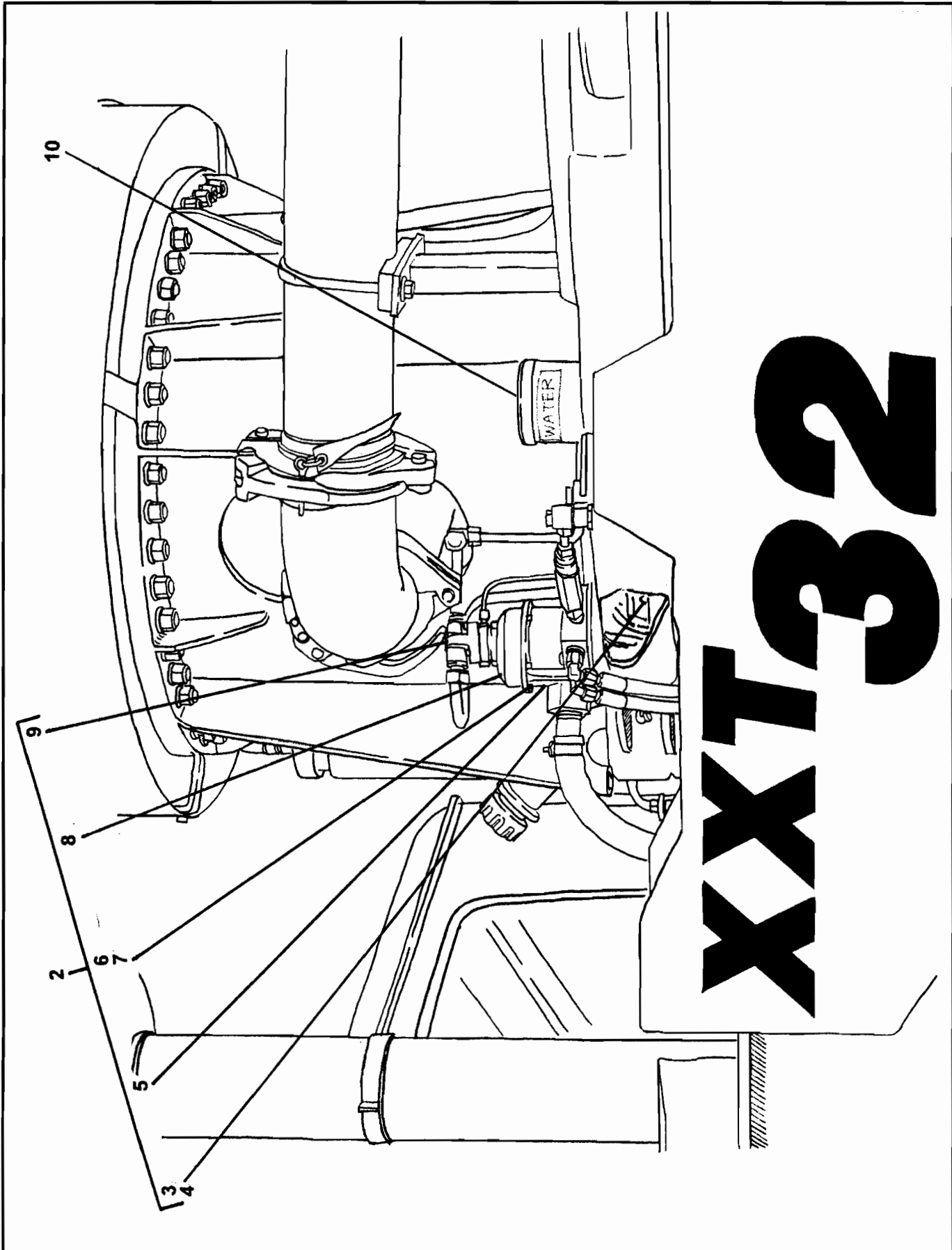

XXT 32

REVISION:

ITEM NO.	REED'S PARTS NO.	1 2 3 4 5	DESCRIPTION	QTY
-1	800750		Group, Water System (See Group 30, Figure 01 for NHA)	Ref
2	W-104176	•	Assembly, Water Pump And Drive	1
3	B-321502	• •	Coupling	1
4	W-103646	• •	Screw, M6	2
5	W-100122	• •	Assembly, Wash Water Pump (See Group 30, Figure 03 for DET)	1
6	W-101838	• •	Screw, M6	8
7	W-103674	• •	Washer, Spring	8
8	B-321505	• •	Flange	1
9	W-100121	• •	Assembly, Water Pump Motor (See Group 30, Figure 04 for DET)	1
10	W-103102	•	Cap, Fill	1

DASH (-) ITEM NOT ILLUSTRATED

REED

WASH WATER PUMP ASSEMBLY

XXT 32
PARTS
GROUP 30
FIGURE 03
PAGE 01

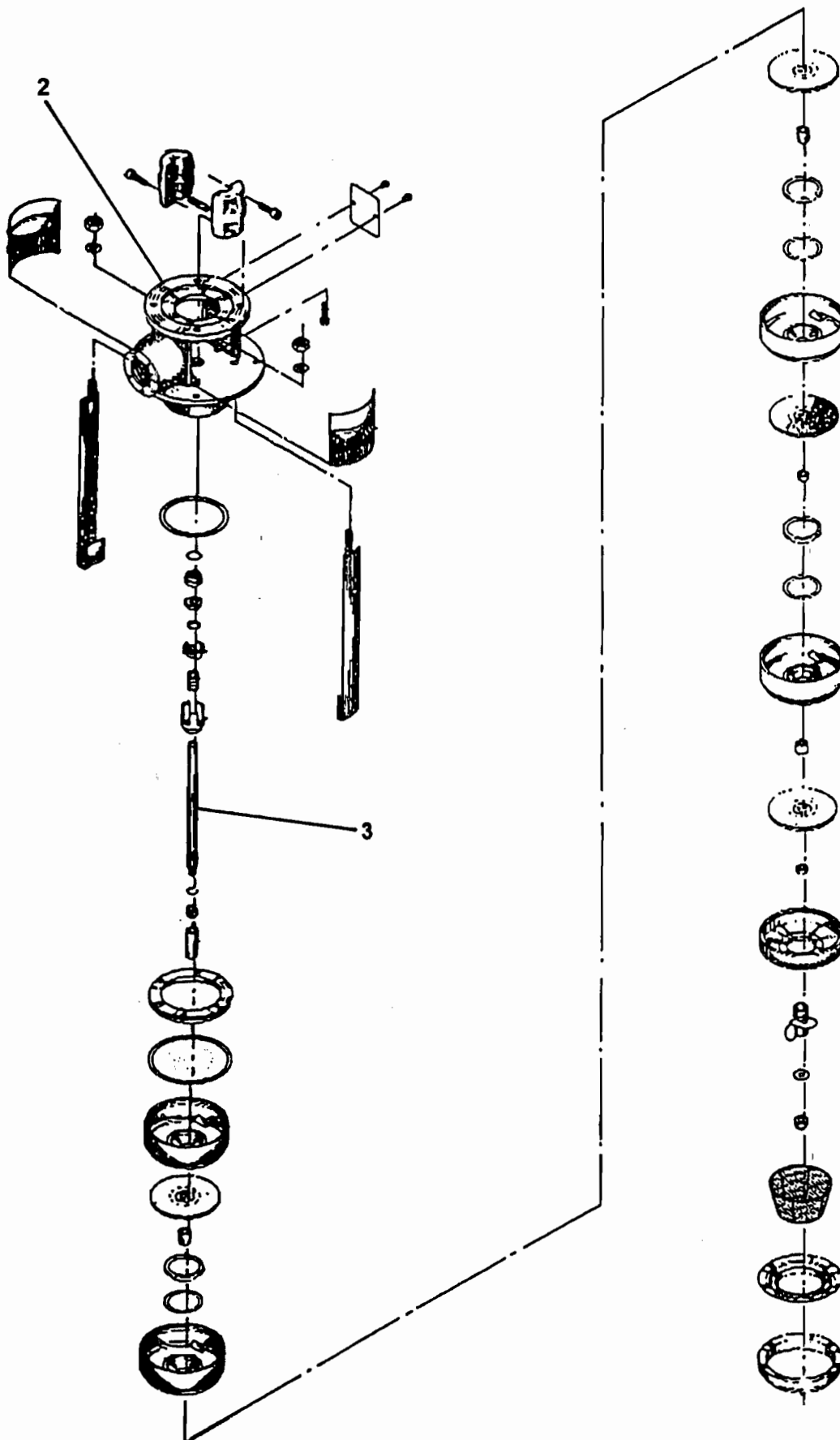

REVISION:

REED**WASH WATER PUMP ASSEMBLY****XXT 32****PARTS**

GROUP 30

FIGURE 03

PAGE 02

ITEM NO.	REED'S PARTS NO.	DESCRIPTION					QTY
		1	2	3	4	5	
-1	W-100122	Assembly, Wash Water Pump (See Group 30, Figure 02 for NHA)					Ref
2	W-105221	• Housing, Pump					1
3	W-105222	• Shaft, Pump					1

DASH (-) ITEM NOT ILLUSTRATED

REVISION:



WATER PUMP MOTOR ASSEMBLY

XXT 32
PARTS
GROUP 30
FIGURE 04
PAGE 01

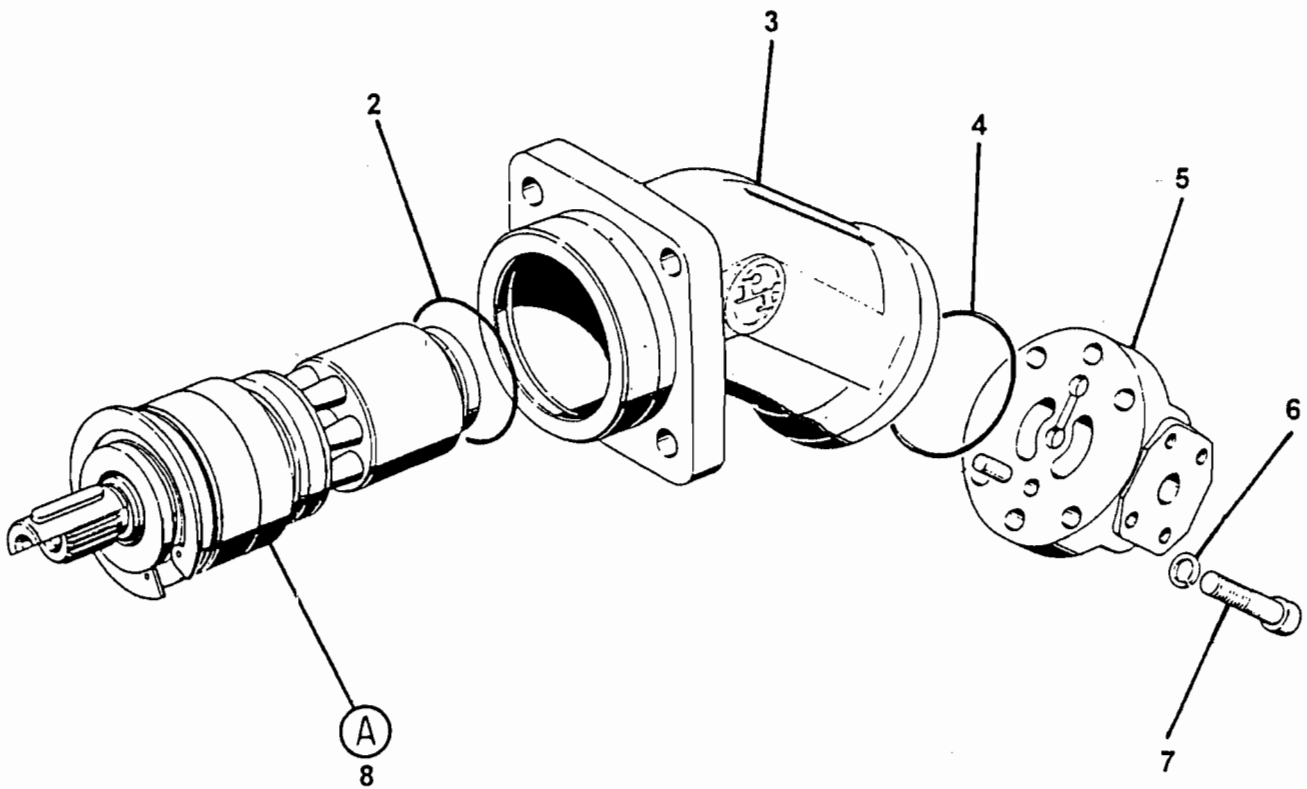

ITEM NO.	REED'S PARTS NO.	DESCRIPTION					QTY
		1	2	3	4	5	
-1	W-100121	Assembly, Water Pump Motor (See Group 30, Figure 02 for NHA)					Ref
2					• O-Ring	1	
3					• Housing	1	
4					• O-Ring	1	
5					• Plate, Port	1	
6					• Washer, Lock	4	
7					• Screw, M6	4	
8					• Sub-Assembly, Rotary	1	
9					• • Ring Retaining	1	
10					• • Cover	1	
11					• • Ring, Shaft Seal	1	
12					• • Ring Retaining	1	
13					• • Bearing, Tapered Roller	1	
14					• • Shim	2	
15					• • Shim	2	
16					• • Shim	2	
17					• • Bearing, Angular Contact Ball	2	
18					• • Key, Shaft	1	
19					• + Shaft, Drive	1	
20					• • Disc	1	
21					• • Plate, Retaining	1	
22					• • Rivet	7	
23					• • Pin, Center	1	
24					• • Cup, Spring	4	
25					• • Collar, Spring	1	
26					• • Shim	1	
27					• • Piston	7	
28					• • Ring, Steel Sealing	7	
29					• • Cylinder	1	
30					• • Plate, Control	1	
31					• Pin	1	

DASH (-) ITEM NOT ILLUSTRATED

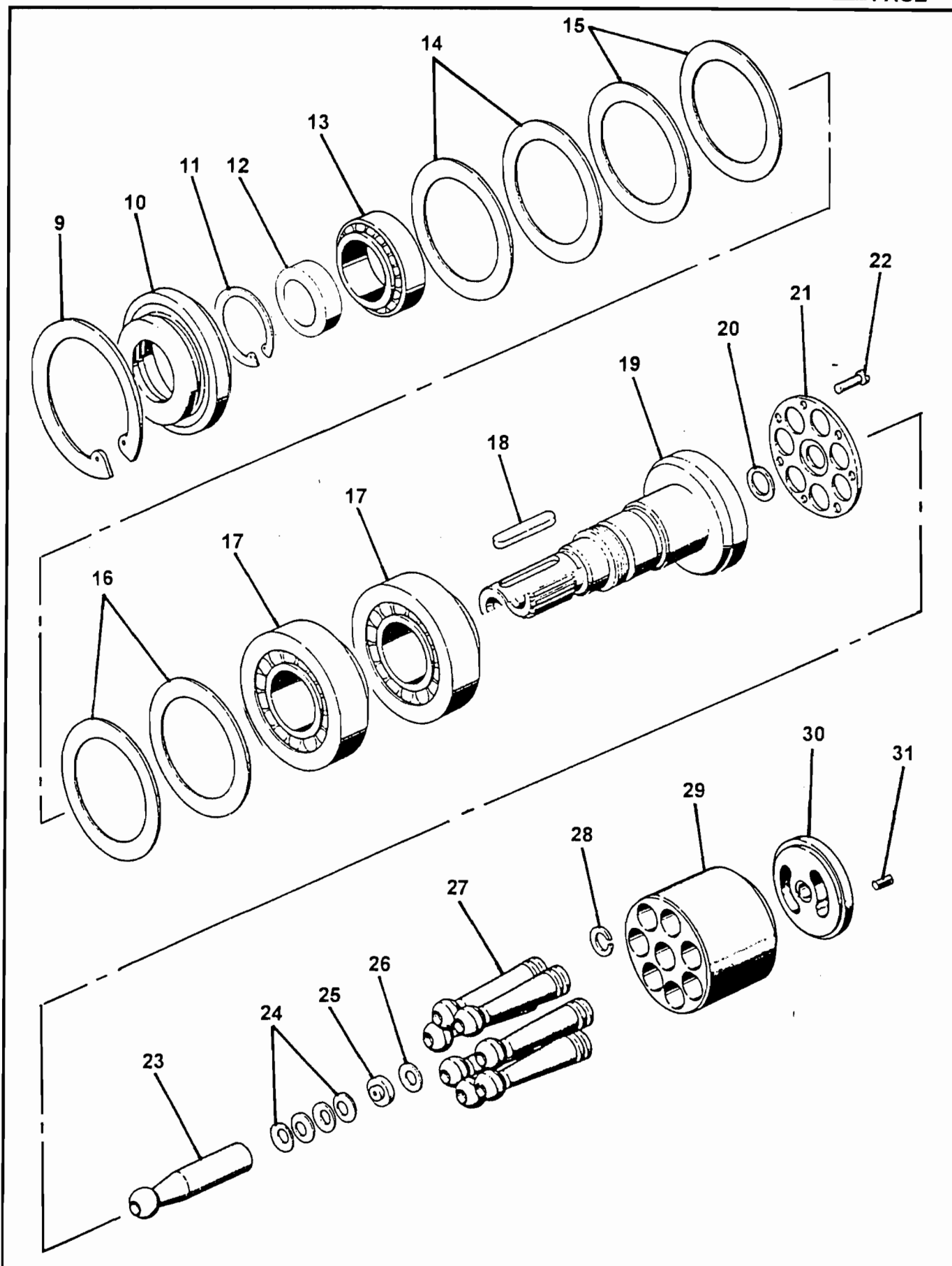

REVISION:

ITEM NO.	REED'S PARTS NO.	DESCRIPTION	QTY
-1	W-100121	Assembly, Water Pump Motor (See Group 30, Figure 02 for NHA)	Ref
2		• O-Ring	1
3		• Housing	1
4		• O-Ring	1
5		• Plate, Port	1
6		• Washer, Lock	4
7		• Screw, M6	4
8		• Sub-Assembly, Rotary	1
9		•• Ring Retaining	1
10		•• Cover	1
11		•• Ring, Shaft Seal	1
12		•• Ring Retaining	1
13		•• Bearing, Tapered Roller	1
14		•• Shim	2
15		•• Shim	2
16		•• Shim	2
17		•• Bearing, Angular Contact Ball	2
18		•• Key, Shaft	1
19		•• Shaft, Drive	1
20		•• Disc	1
21		•• Plate, Retaining	1
22		•• Rivet	7
23		•• Pin, Center	1
24		•• Cup, Spring	4
25		•• Collar, Spring	1
26		•• Shim	1
27		•• Piston	7
28		•• Ring, Steel Sealing	7
29		•• Cylinder	1
30		•• Plate, Control	1
31		•• Pin	1

DASH (-) ITEM NOT ILLUSTRATED

REED

**MODEL XXT 32 TRUCK MOUNTED
CONCRETE BOOM PUMP
ILLUSTRATED PARTS MANUAL**

**XXT 32
PARTS
GROUP 30
FIGURE 05
PAGE 01**

THIS PAGE INTENTIONALLY LEFT BLANK.

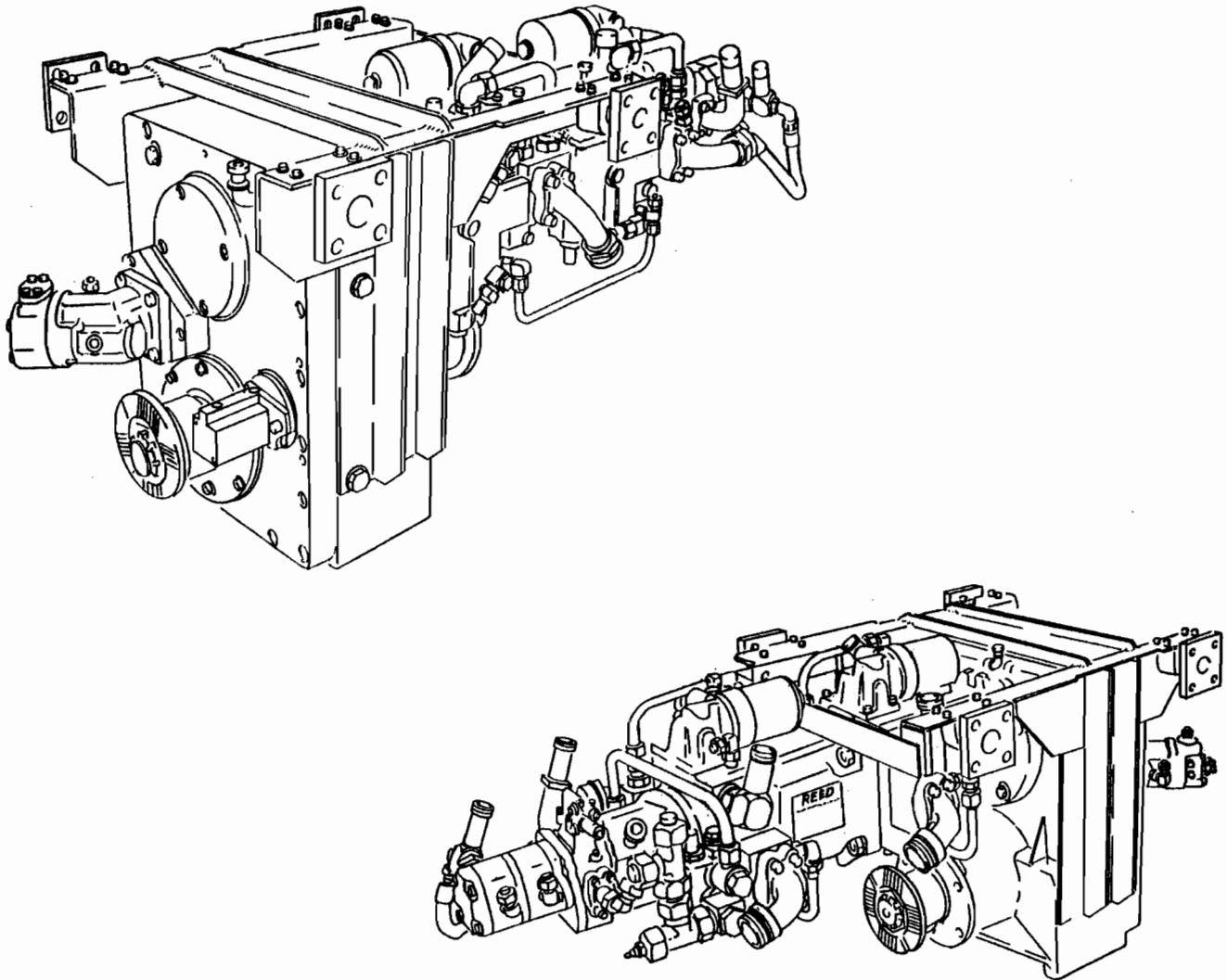

SHOWN MODEL: AFTER MARCH 2001

REED TRUCK MOUNTED CONCRETE BOOM PUMP MODEL XXT 32 ILLUSTRATED PARTS MANUAL GROUP 40 POWER TRAIN INSTALLATION CONTAINS THE FOLLOWING FIGURES:

FIGURE 00	TABLE OF CONTENTS
FIGURE 01	POWER TRAIN INSTALLATION (BEF JUL 1999)
FIGURE 02	POWER TRAIN INSTALLATION (AUG 1999 ~ MAR 2000)
FIGURE 03	POWER TRAIN INSTALLATION (APR 2000 ~ FEB 2001)
FIGURE 04	POWER TRAIN INSTALLATION (AFT MAR 2001)
FIGURE 05	GEAR PUMP ASSEMBLY
FIGURE 06	PTO GEARBOX ASSEMBLY

BEFORE JULY 1999

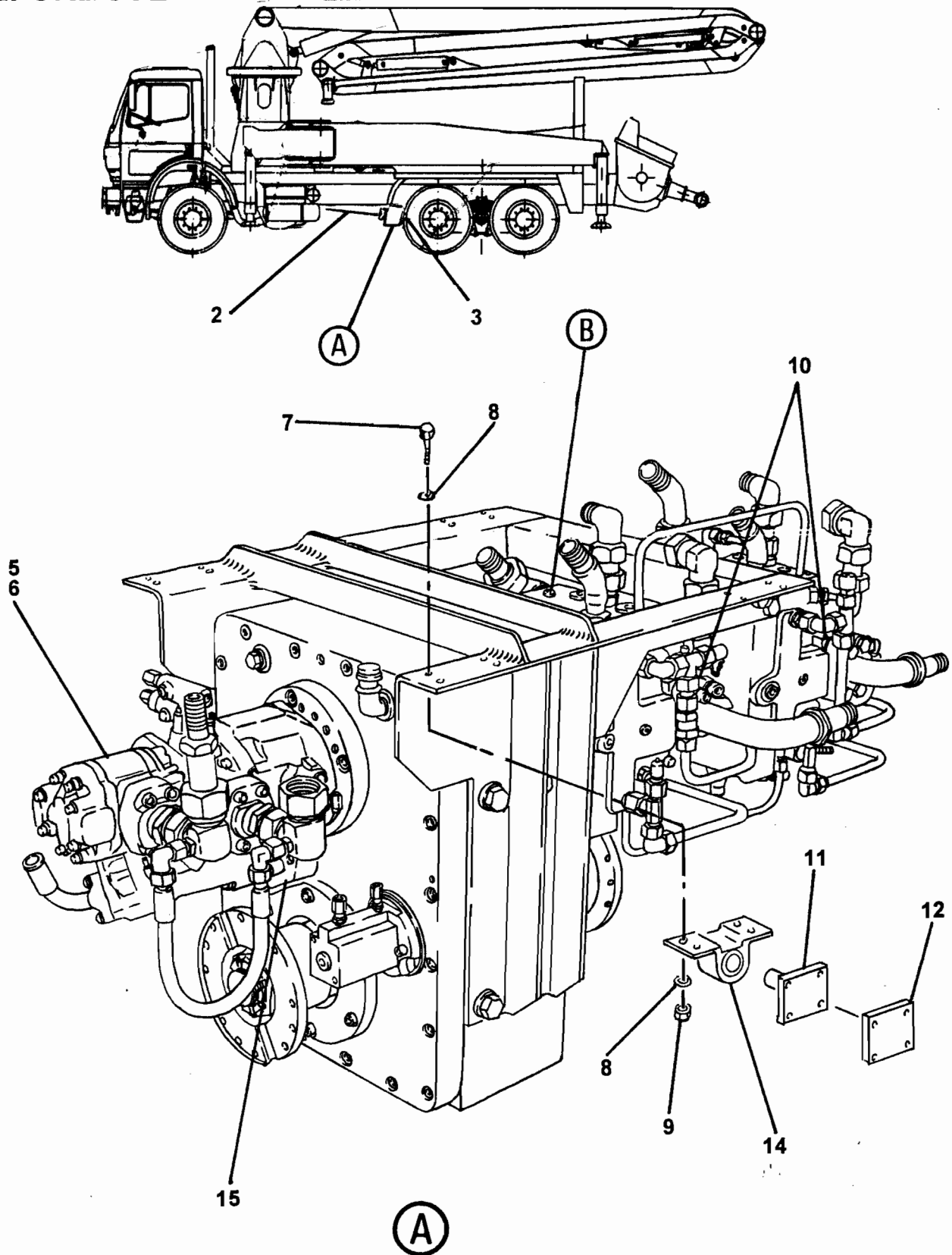

BEFORE JULY 1999

ITEM NO.	REED'S PARTS NO.	DESCRIPTION					QTY
		1	2	3	4	5	
-1	40-01	Installation, Power Train (Before Jul 1999) (See Group 10, Figure 01 for NHA)					Ref
2	801059	• Shaft, Front Drive					1
3	801289	• Shaft, Rear Drive					1
4	800607	• Group, XXT 32 Gearbox					1
5	801022	• Assembly, Gear Pump					1
6	800061	• • O-Ring					1
7		• • Bolt, Hex					16
8		• • Washer					32
9		• • Nut, Lock					16
10	801057	• • Manifold, Pump					3
11	800125	• • Axle, PTO Mount					4
12	800128	• • Plate, PTO Axle Mount					4
13	W-105055	• • Assembly, PTO Gearbox with Rexroth					1
14	W-103414	• • • Buffer, Rubber					4
15	W-104703	• • • Assembly, S-Tube Circuit Pump					1
16	W-103511	• • • Assembly, Boom Pump					1
17	W-104527	• • • Assembly, PTO Gearbox					1
18	W-105513	• • • • Switch, PTO Gearbox					1
19	W-104704	• • • Assembly, Rexroth Pump					2
20	W-104949	• • • Valve, Main Pump Flushing					1
21	801087	• • Mount, PTO Gearbox with Rexroth					1
22	801058	• • Manifold, Boom Pump					1
23	801088	• • Brace, PTO Mount					1
-24	800063	• • Valve, Air					1
-25	800064	• • Muffler, Air Valve					1

DASH (-) ITEM NOT ILLUSTRATED

BEFORE JULY 1999

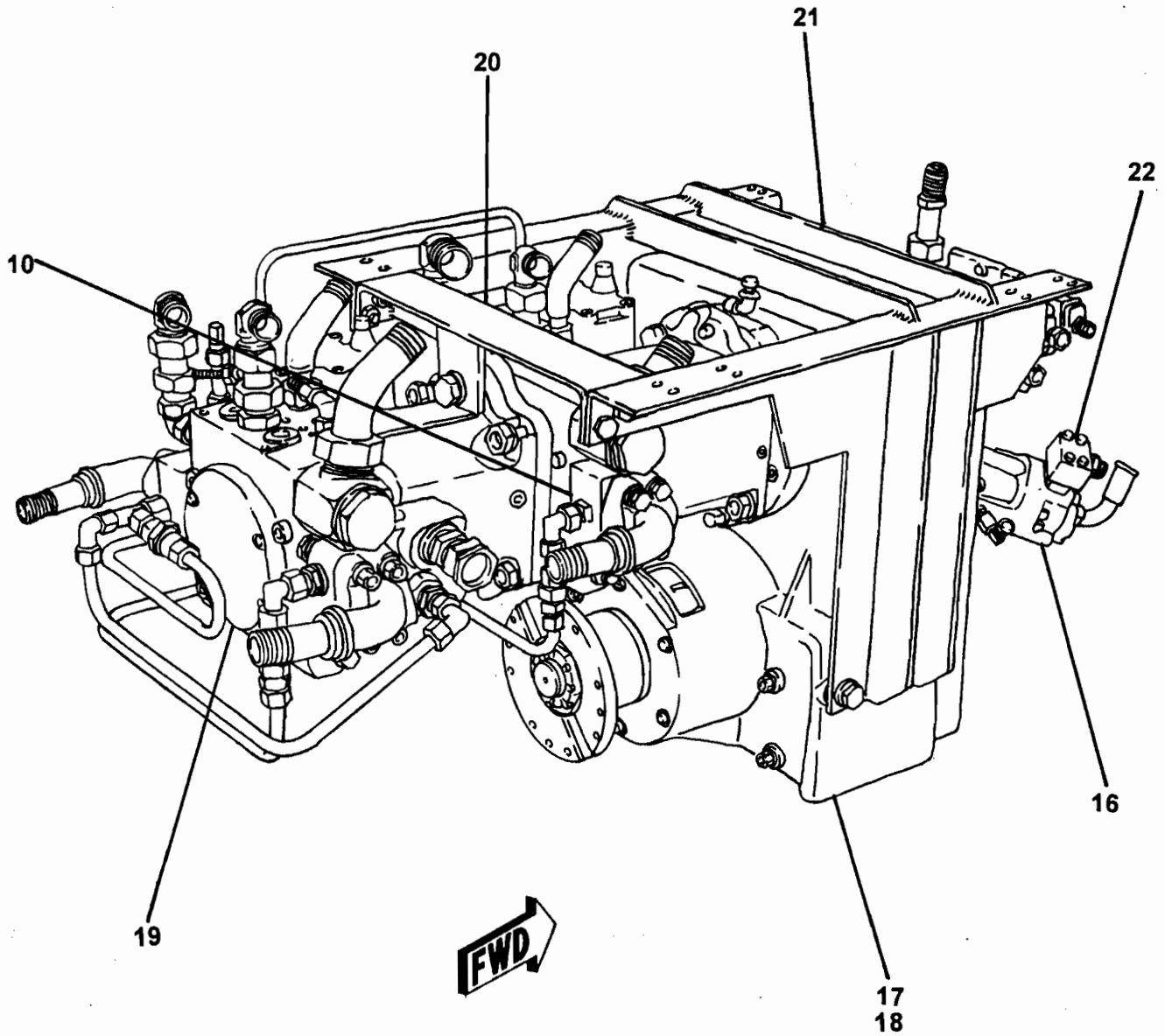

BEFORE JULY 1999

ITEM NO.	REED'S PARTS NO.	DESCRIPTION					QTY
		1	2	3	4	5	
-1	40-01	Installation, Power Train (Before Jul 1999) (See Group 10, Figure 01 for NHA)					Ref
2	801059	• Shaft, Front Drive					1
3	801289	• Shaft, Rear Drive					1
4	800607	• Group, XXT 32 Gearbox					1
5	801022	• Assembly, Gear Pump					1
6	800061	•• O-Ring					1
7		•• Bolt, Hex					16
8		•• Washer					32
9		•• Nut, Lock					16
10	801057	•• Manifold, Pump					3
11	800125	•• Axle, PTO Mount					4
12	800128	•• Plate, PTO Axle Mount					4
13	W-105055	•• Assembly, PTO Gearbox with Rexroth					1
14	W-103414	••• Buffer, Rubber					4
15	W-104703	••• Assembly, S-Tube Circuit Pump					1
16	W-103511	••• Assembly, Boom Pump					1
17	W-104527	••• Assembly, PTO Gearbox					1
18	W-105513	•••• Switch, PTO Gearbox					1
19	W-104704	••• Assembly, Rexroth Pump					2
20	W-104949	••• Valve, Main Pump Flushing					1
21	801087	•• Mount, PTO Gearbox with Rexroth					1
22	801058	•• Manifold, Boom Pump					1
23	801088	•• Brace, PTO Mount					1
-24	800063	•• Valve, Air					1
-25	800064	•• Muffler, Air Valve					1

DASH (-) ITEM NOT ILLUSTRATED

AUGUST 1999 ~ MARCH 2000

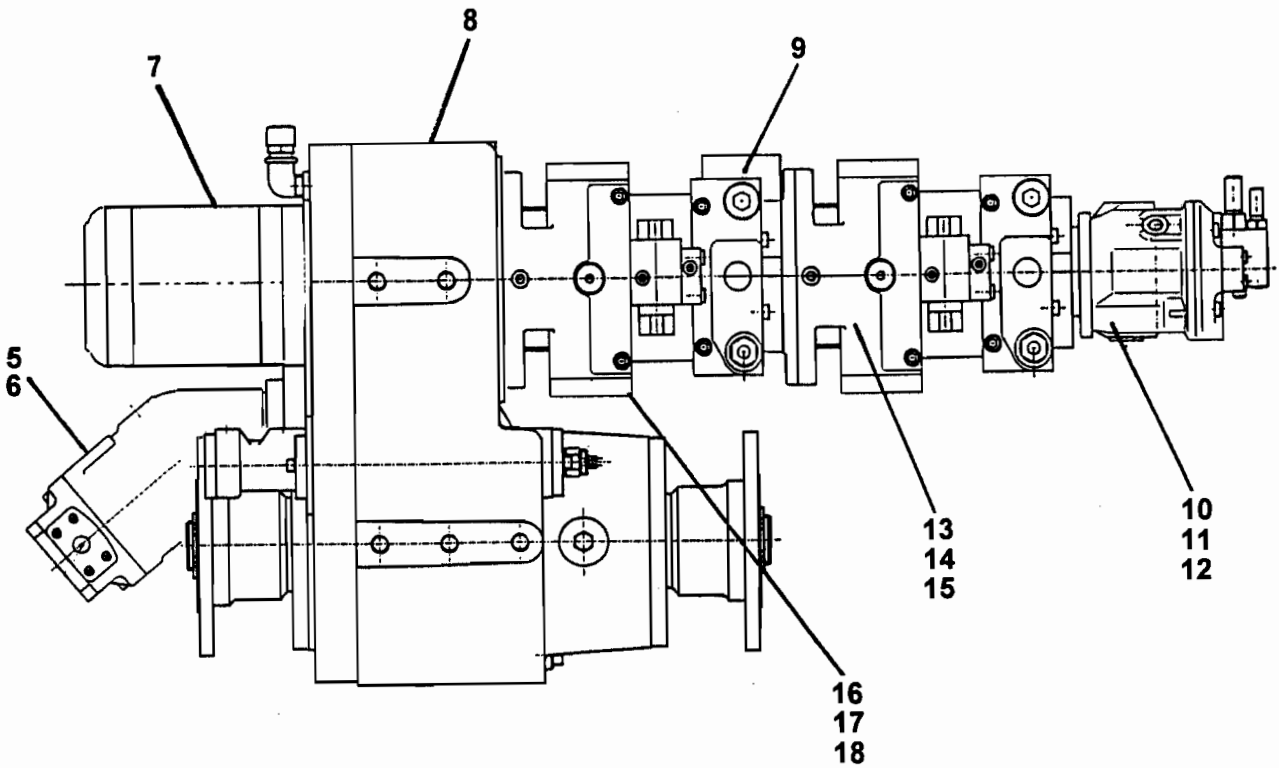
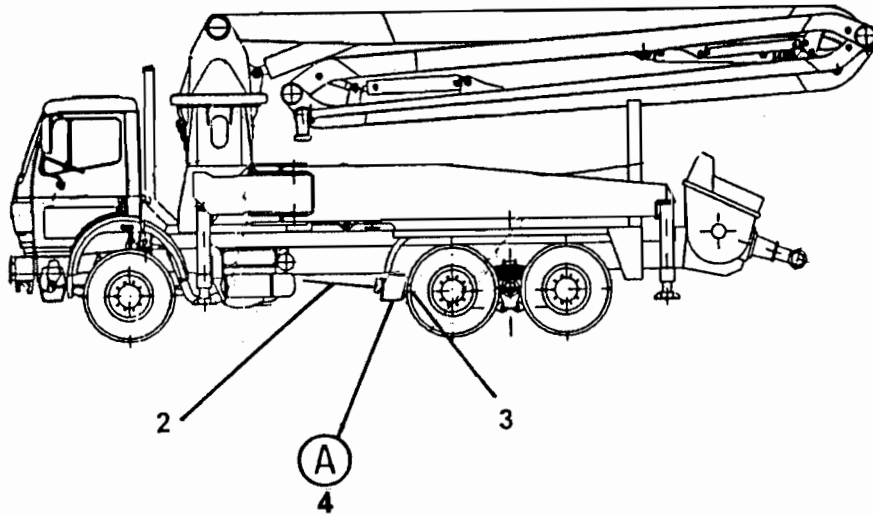

(A)

AUGUST 1999 ~ MARCH 2000

ITEM NO.	REED'S PARTS NO.	DESCRIPTION					QTY
		1	2	3	4	5	
-1	40-02	Installation, Power Train (Aug 1999 ~ Mar 2000) (See Group 10, Figure 01 for NHA)					Ref
2	801480	• Shaft, Front Drive					1
3	801481	• Shaft, Rear Drive					1
4	W-105340	• Group, XXT 32 Gearbox (Aug 1999 ~ Mar 2000)					1
5	W-103623	• • Assembly, Boom Pump					1
6	801058	• • Manifold, Boom Pump					1
7	801397	• • Assembly, 4/4CC Gear Pump					1
8	W-104870	• • Assembly, PTO Gearbox					1
9	W-104949	• • Valve, Flushing					1
10	W-105594	• • Assembly, A10VO28 Gear Pump					1
11	W-105789	• • • Kit, A10VO28 Gear Pump Seal					1
12	W-105001	• • • Seal, Shaft					1
13	W-105592	• • Assembly, A4VG125 Gear Pump					1
14	W-105787	• • • Kit, A4VG125Gear Pump Seal					1
15	W-105788	• • • Seal, Shaft					1
16	W-105591	• • Assembly, A4VG125 Gear Pump					1
17	W-105785	• • • Kit, A4VG125Gear Pump Seal					1
18	W-105786	• • • Seal, Shaft					1

DASH (-) ITEM NOT ILLUSTRATED

APRIL 2000 ~ FEBRUARY 2001

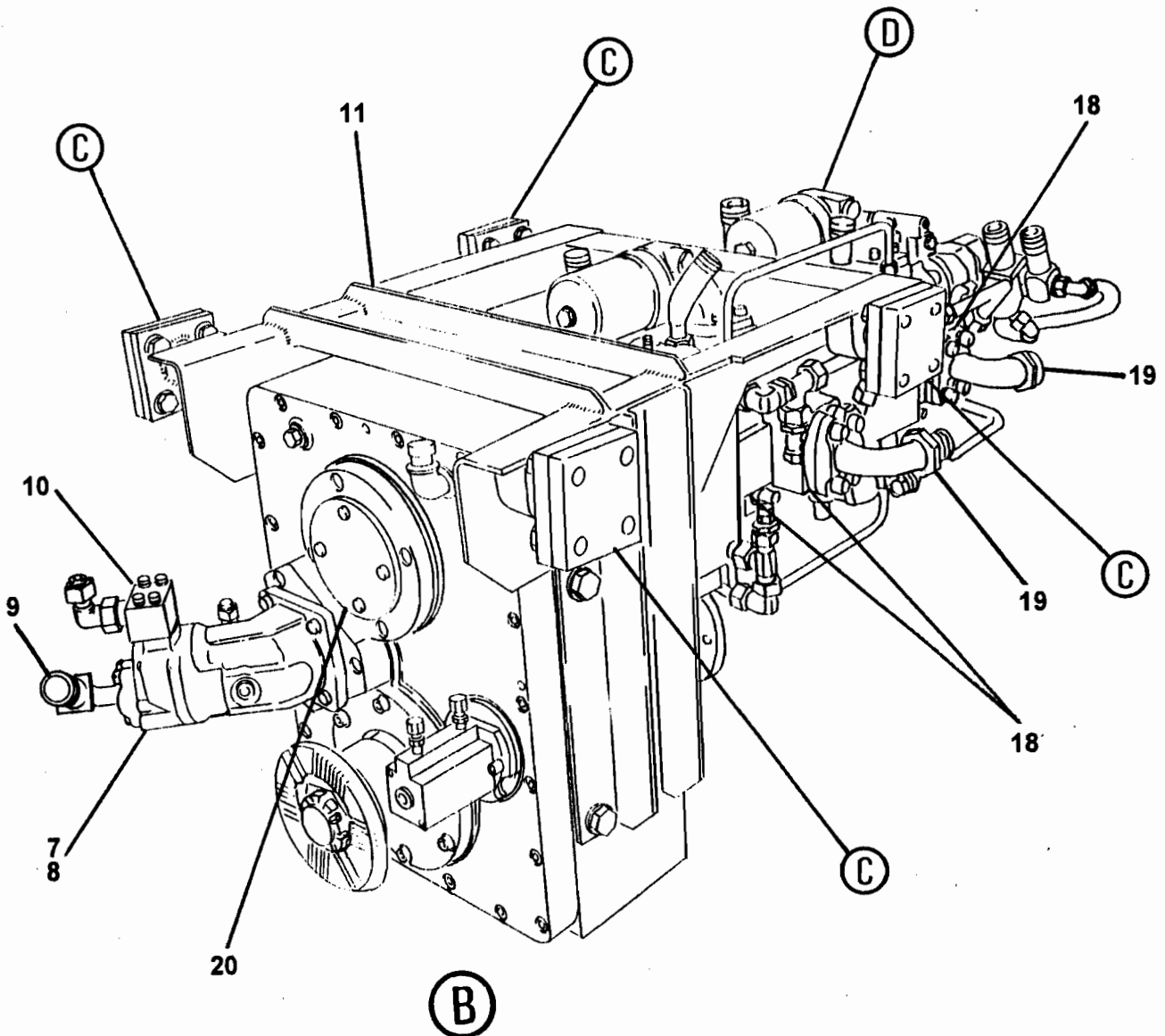
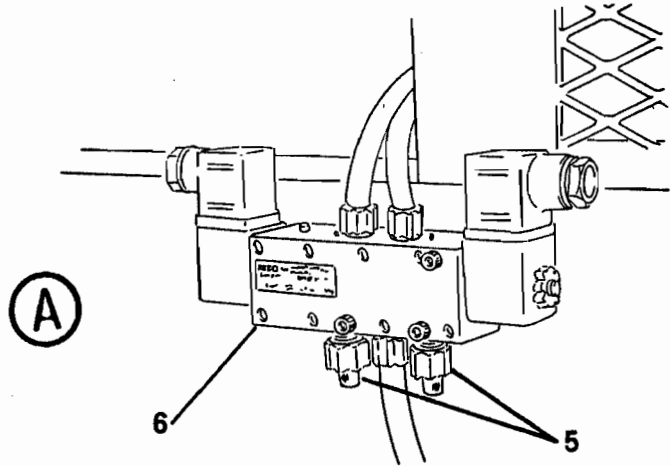
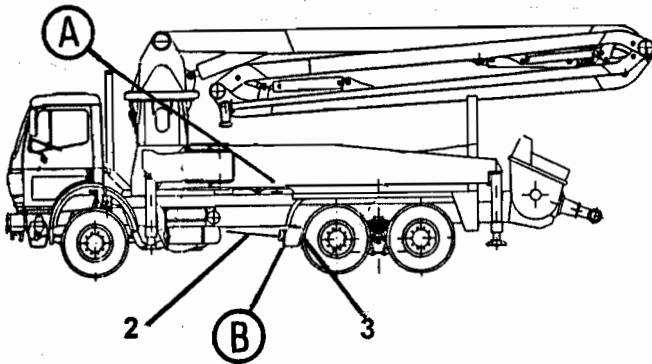

APRIL 2000 ~ FEBRUARY 2001

ITEM NO.	REED'S PARTS NO.	DESCRIPTION					QTY
		1	2	3	4	5	
-1	40-03	Installation, Power Train (Apr 2000 ~ Feb 2001) (See Group 10, Figure 01 for NHA)					Ref
2	801973	• Shaft, Front Drive					1
3	801974	• Shaft, Rear Drive					1
-4	800610	• Group, XXT 36 Gearbox					1
5	800064	• • Muffler, Air Valve					2
6	800063	• • Valve, Air					1
7	W-103623	• • Assembly, Boom Pump					1
8	W-105629	• • • Seal, Boom Pump Shaft					1
9	801511	• • Adapter, 90L					1
10	801058	• • Manifold, Boom Pump					1
11	801087	• • Mount, PTO Gearbox with Rexroth					1
12		• • Bolt, Hex					16
13		• • Washer					32
14		• • Nut, Lock					16
15	W-103414	• • Buffer, Rubber					4
16	800125	• • Axle, PTO Mount					4
17	800128	• • Plate, PTO Axle Mount					4
18	801778	• • Manifold, Pump					2
19	801503	• • Adapter, 90L					4
20	75861	• • Cover, Bolt Housing					1
21	801510	• • Adapter, 90L					1
22	801516	• • Adapter, STR					1
23	801684	• • Assembly, 4/4CC Gear Pump					1
24	800061	• • • O-Ring, Gear Pump					1
25	801512	• • Adapter, 90L					1
26	W-105650	• • Assembly, Gear Pump (See Group 40, Figure 05 for DET)					1
27	801506	• • Adapter, 90L					2
28	801526	• • Adapter, STR					2
29	801527	• • Adapter, STR					1
30	801057	• • Manifold, Pump					2
31	W-105539	• • Assembly, PTO Gearbox (See Group 40, Figure 06 for DET)					1
32	W-105513	• • • Switch, PTO Gearbox					1
33	801499	• • Filter, Charge Pump					2
34	801500	• • • Element, Charge Pump Filter					2
35	801088	• • Brace, PTO Mount					1
36	W-105075	• • Adapter, 90L					1

DASH (-) ITEM NOT ILLUSTRATED

AUGUST 1999 ~ MARCH 2000

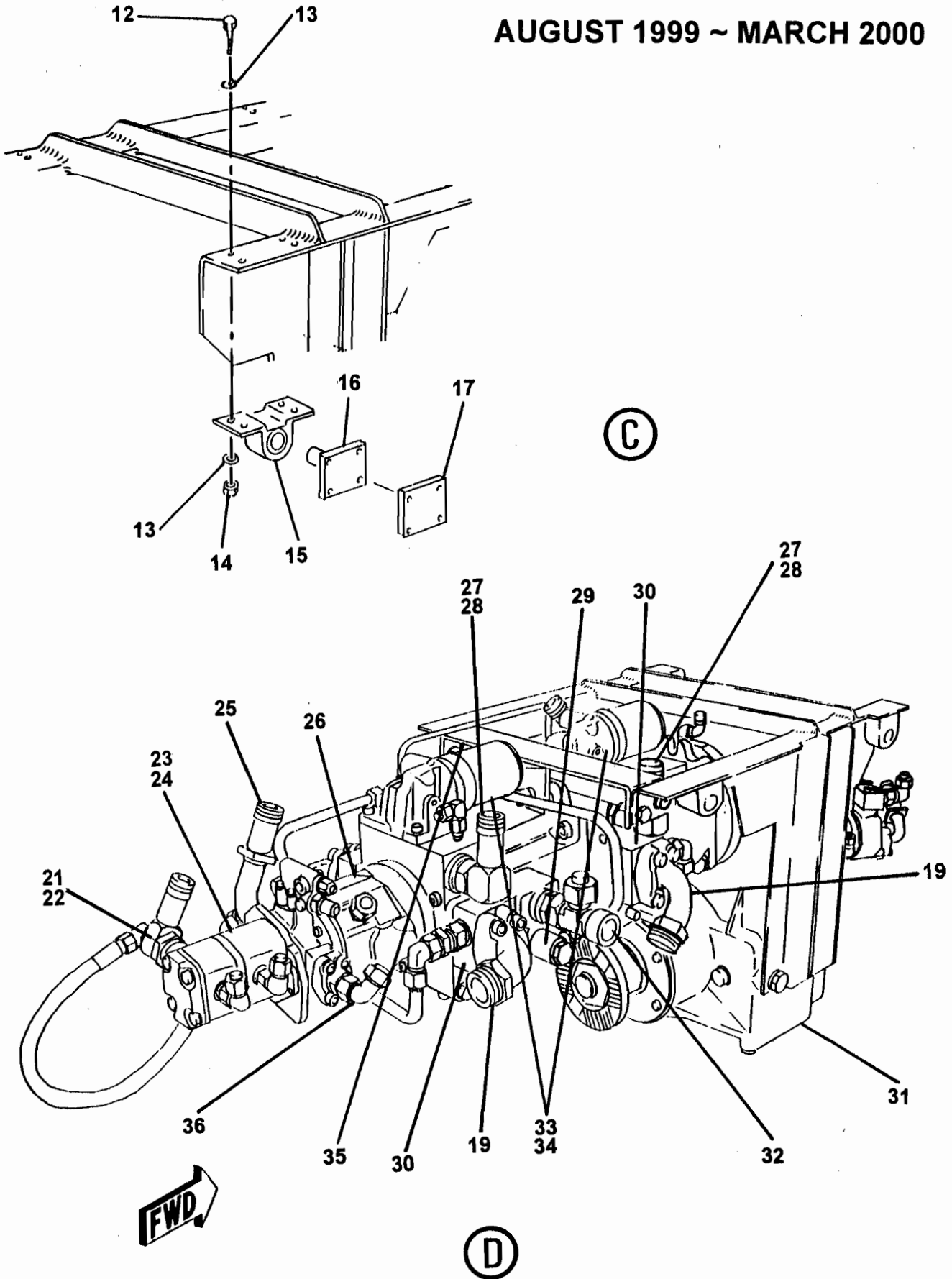

APRIL 2000 ~ FEBRUARY 2001

ITEM NO.	REED'S PARTS NO.	DESCRIPTION	QTY
-1	40-03	Installation, Power Train (Apr 2000 ~ Feb 2001) (See Group 10, Figure 01 for NHA)	Ref
2	801973	• Shaft, Front Drive	1
3	801974	• Shaft, Rear Drive	1
-4	800610	• Group, XXT 36 Gearbox	1
5	800064	• • Muffler, Air Valve	2
6	800063	• • Valve, Air	1
7	W-103623	• • Assembly, Boom Pump	1
8	W-105629	• • • Seal, Boom Pump Shaft	1
9	801511	• • Adapter, 90L	1
10	801058	• • Manifold, Boom Pump	1
11	801087	• • Mount, PTO Gearbox with Rexroth	1
12		• • Bolt, Hex	16
13		• • Washer	32
14		• • Nut, Lock	16
15	W-103414	• • Buffer, Rubber	4
16	800125	• • Axle, PTO Mount	4
17	800128	• • Plate, PTO Axle Mount	4
18	801778	• • Manifold, Pump	2
19	801503	• • Adapter, 90L	4
20	75861	• • Cover, Bolt Housing	1
21	801510	• • Adapter, 90L	1
22	801516	• • Adapter, STR	1
23	801684	• • Assembly, 4/4CC Gear Pump	1
24	800061	• • • O-Ring, Gear Pump	1
25	801512	• • Adapter, 90L	1
26	W-105650	• • Assembly, Gear Pump (See Group 40, Figure 05 for DET)	1
27	801506	• • Adapter, 90L	2
28	801526	• • Adapter, STR	2
29	801527	• • Adapter, STR	1
30	801057	• • Manifold, Pump	2
31	W-105539	• • Assembly, PTO Gearbox (See Group 40, Figure 06 for DET)	1
32	W-105513	• • • Switch, PTO Gearbox	1
33	801499	• • Filter, Charge Pump	2
34	801500	• • • Element, Charge Pump Filter	2
35	801088	• • Brace, PTO Mount	1
36	W-105075	• • Adapter, 90L	1

DASH (-) ITEM NOT ILLUSTRATED

AFTER MARCH 2001

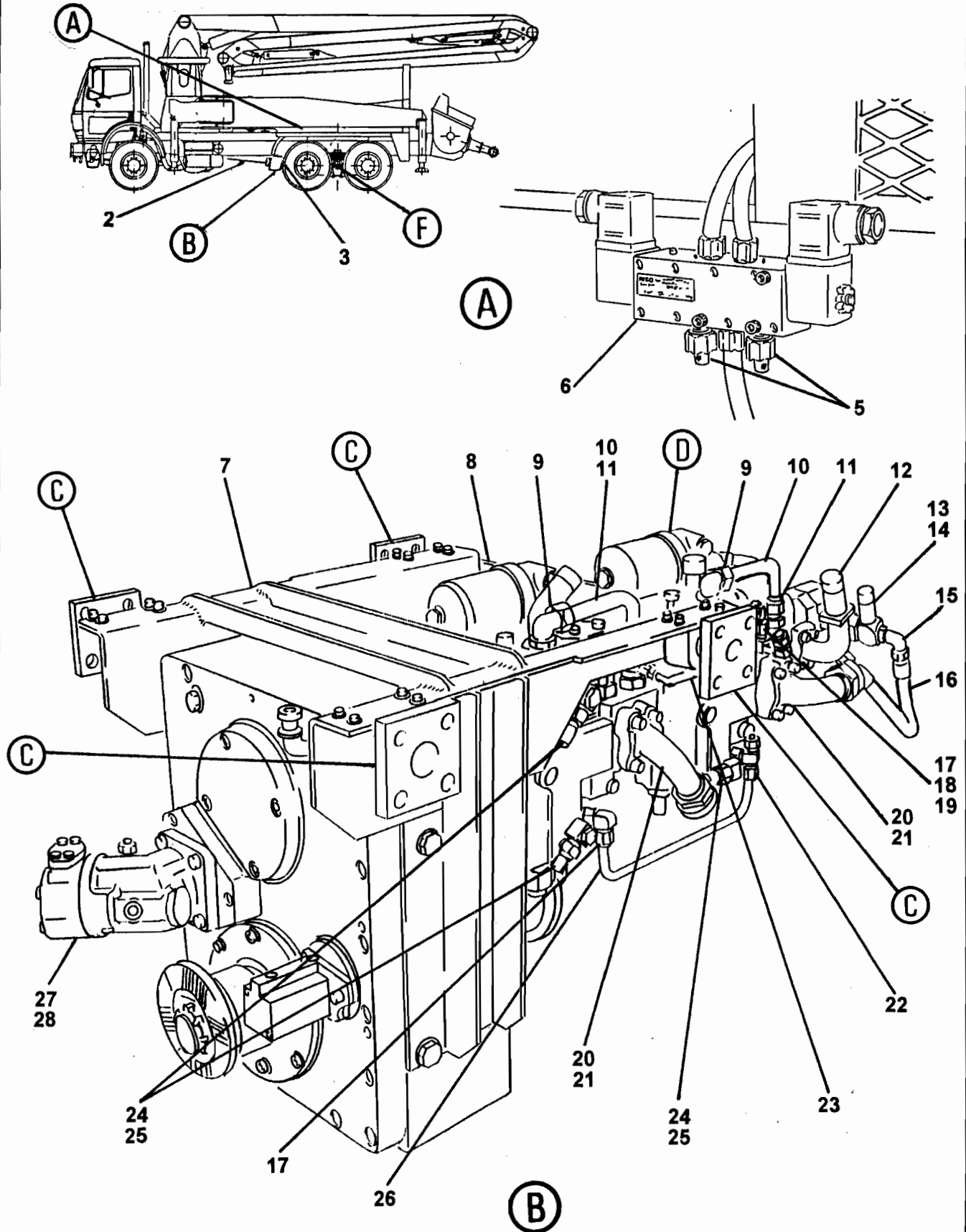



**POWER TRAIN INSTALLATION
(AFTER MARCH 2001)**

**XXT 32
PARTS
GROUP 40
FIGURE 04
PAGE 02**

AFTER MARCH 2001

ITEM NO.	REED'S PARTS NO.	DESCRIPTION					QTY
		1	2	3	4	5	
-1	40-01	Installation, Power Train (Aft Mar 2001) (See Group 10, Figure 01 for NHA)					Ref
2	801973	• Shaft, Front Drive					1
3	801974	• Shaft, Rear Drive					1
-4	800610	• Installation, XXT 32 PTO Gearbox					1
5	800064	• • Muffler, Air Valve					2
6	800063	• • Valve, Air					1
7	801788	• • Mount, PTO Gearbox with Rexroth					1
8	801792	• • Brace, PTO Mount					1
9	801888-005	• • Swivel, Elbow					7
10	801793	• • Assembly, Tube					2
11		• • Adapter, STR					2
12	801512	• • Adapter, 90L					1
13	801510	• • Adapter, 90L					1
14	801516	• • Adapter, STR					1
15	801888-014	• • Swivel, Elbow					3
16	801486-005	• • Assembly, Hose					1
17	801888-003	• • Swivel, Elbow					3
18	801890-003	• • Swivel, Tee					1
19	W-105076	• • Port, Pressure Test					3
20	801778	• • Manifold, Pump					2
21	801503	• • Adapter, 90L					4
22	801889-003	• • Swivel, Tee					1
23	802339	• • Assembly, Tube					1
24	801874-003	• • Banjo					4
25	W-104831	• • Port, Pressure Test					4
26	801797	• • Assembly, Tube					1
27	W-103623	• • Assembly, Boom Pump					1
28	W-105925	• • • Seal, Boom Pump Shaft					1

DASH (-) ITEM NOT ILLUSTRATED

AFTER MARCH 2001

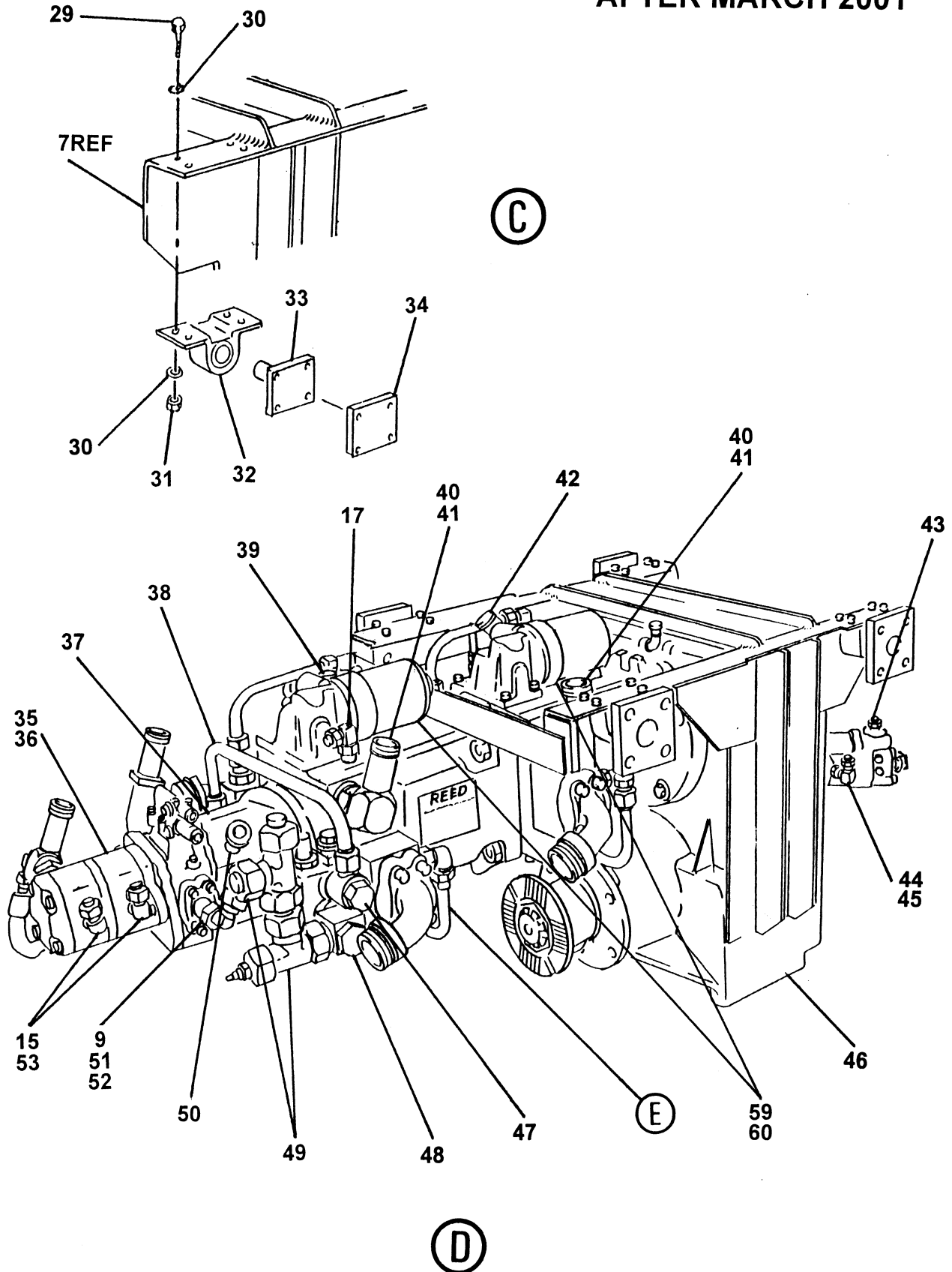



POWER TRAIN INSTALLATION (AFTER MARCH 2001)

XXT 32
PARTS
GROUP 40
FIGURE 04
PAGE 04

AFTER MARCH 2001

ITEM NO.	REED'S PARTS NO.	1 2 3 4 5	DESCRIPTION	QTY
29		••	Bolt, Hex	16
30		••	Washer	32
31		••	Nut, Lock	16
32	W-103414	••	Buffer, Rubber	4
33	800125	••	Axle, PTO Mount	4
34	800128	••	Plate, PTO Axle Mount	4
35	801684	••	Assembly, 4/4CC Pump	1
36	800061	•••	O-Ring, 4/4CC Pump	1
37	W-105650	••	Assembly, Gear Pump (See Group 40, Figure 02 for DET)	1
38	801796	••	Assembly, Tube	1
39	W-105170	••	Adapter, STR	1
40	801506	••	Adapter, 90L	2
41	801526	••	Adapter, STR	2
42	W-105169	••	Adapter, 45	1
43	801873-011	••	Adapter	1
44	801524	••	Adapter, STR	1
45	801509	••	Adapter, 90L	1
46	802242	••	Assembly, PTO Gear Box (See Group 40, Figure 03 for DET)	1
47	801527	••	Adapter, STR	1
48		••	Banjo	1
49	801890-006	••	Swivel, Tee	2
50	801876-005	••	Adapter, STR	1
51	86264-002	••	Flange, Split	1
52	W-105075	••	Adapter, STR	1
53	801876-003	••	Adapter	2
54	801057	••	Manifold, Pump	2
55	801794	••	Assembly, Tube	1
56	801795	••	Assembly, Tube	1
57	W-105567	••	Sensor, Thermal	1
58	801927	••	Adapter, Thermal Sensor	1
59	801499	••	Filter, A4VG125 Charge Pump	2
60	801500	•••	Element, A4VG125 Charge Pump Filter	2

DASH (-) ITEM NOT ILLUSTRATED

AFTER MARCH 2001

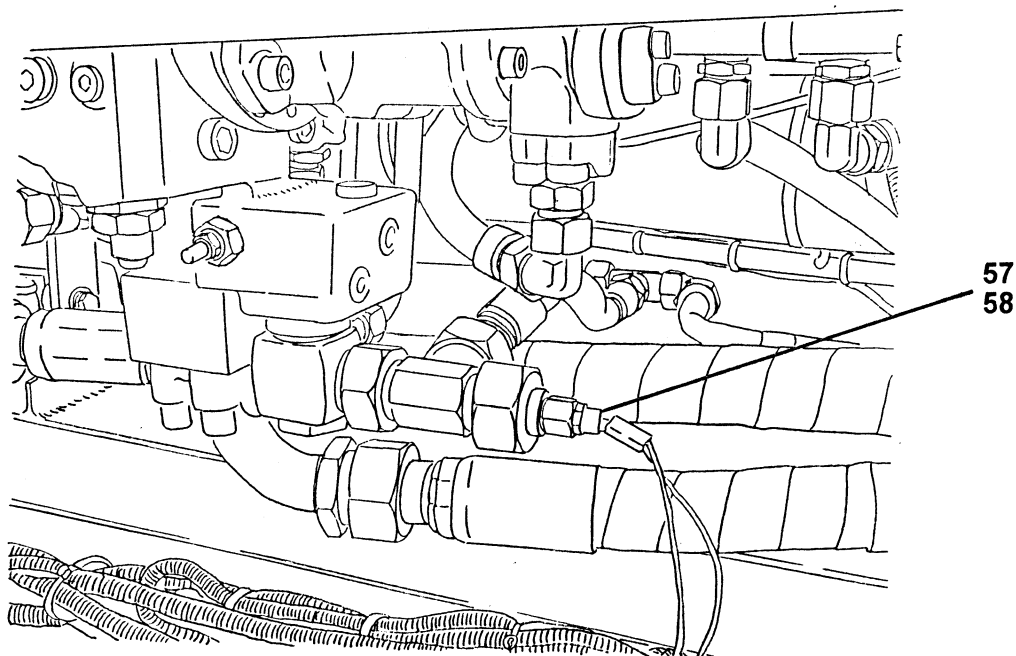
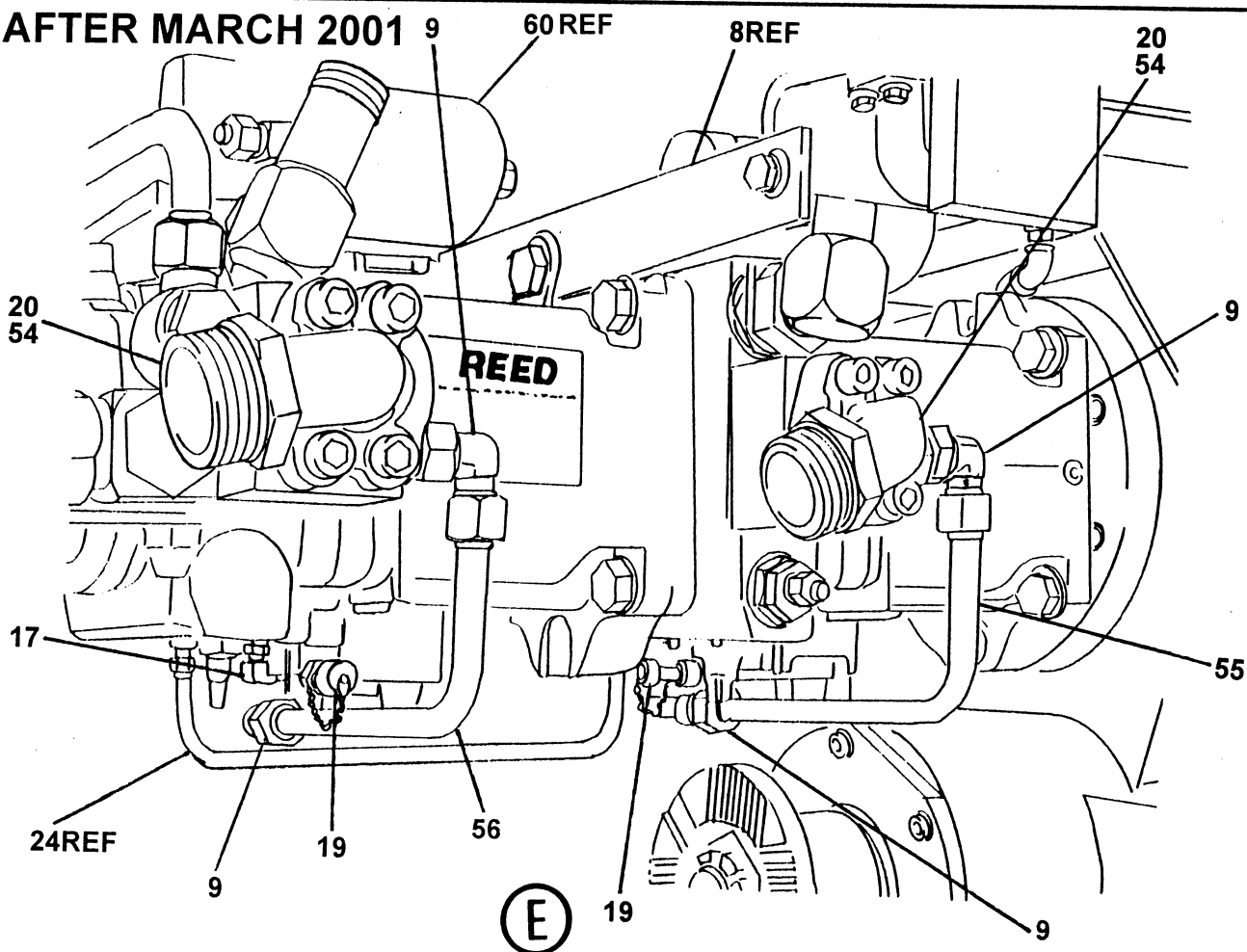

AFTER MARCH 2001

ITEM NO.	REED'S PARTS NO.	1 2 3 4 5	DESCRIPTION	QTY
29		• •	Bolt, Hex	16
30		• •	Washer	32
31		• •	Nut, Lock	16
32	W-103414	• •	Buffer, Rubber	4
33	800125	• •	Axle, PTO Mount	4
34	800128	• •	Plate, PTO Axle Mount	4
35	801684	• •	Assembly, 4/4CC Gear Pump	1
36	800061	• • •	O-Ring, Gear Pump	1
37	W-105650	• •	Assembly, Gear Pump (See Group 40, Figure 02 for DET)	1
38	801796	• •	Assembly, Tube	1
39	W-105170	• •	Adapter, STR	1
40	801506	• •	Adapter, 90L	2
41	801526	• •	Adapter, STR	2
42	W-105169	• •	Adapter, 45	1
43	801873-011	• •	Adapter	1
44	801524	• •	Adapter, STR	1
45	801509	• •	Adapter, 90L	1
46	802242	• •	Assembly, PTO Gear Box (See Group 40, Figure 03 for DET)	1
47	801527	• •	Adapter, STR	1
48		• •	Banjo	1
49	801890-006	• •	Swivel, Tee	2
50	801876-005	• •	Adapter, STR	1
51	86264-002	• •	Flange, Split	1
52	W-105075	• •	Adapter, STR	1
53	801876-003	• •	Adapter	2
54	801057	• •	Manifold, Pump	2
55	801794	• •	Assembly, Tube	1
56	801795	• •	Assembly, Tube	1
57	W-105567	• •	Sensor, Thermal	1
58	801927	• •	Adapter, Thermal Sensor	1
59	801499	• •	Filter, A4VG125 Charge Pump	2
60	801500	• • •	Element, A4VG125 Charge Pump Filter	2

DASH (-) ITEM NOT ILLUSTRATED



GEAR PUMP ASSEMBLY

XXT 32
PARTS
GROUP 40
FIGURE 05
PAGE 01

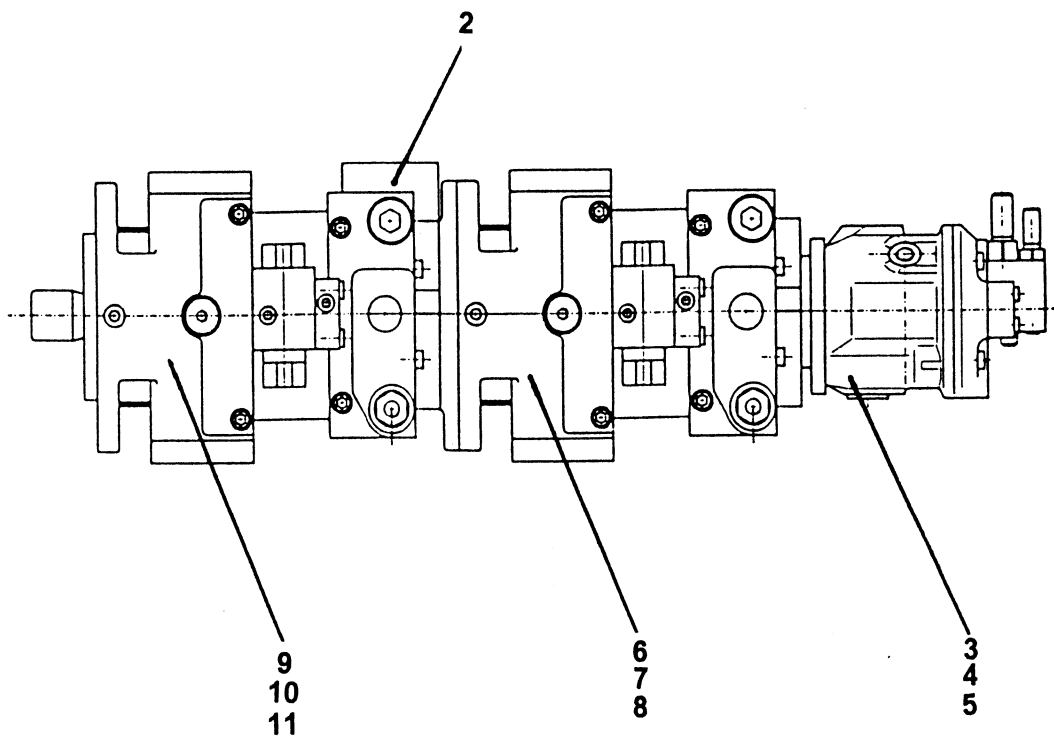



GEAR PUMP ASSEMBLY

XXT 32
PARTS
GROUP 40
FIGURE 05
PAGE 02

ITEM NO.	REED 'S PARTS NO.	DESCRIPTION					QTY
		1	2	3	4	5	
-1	W-105650	Assembly, Gear Pump (See Group 40, Figure 03 and 04 for NHA)					1
2	W-104949	• Valve, Flushing					1
3	W-105651	• Assembly, A10VO28 Gear Pump					1
4	W-105789	• • Kit, A10VO28 Gear Pump Seal					1
5	W-105001	• • Seal, Shaft					1
6	W-105592	• Assembly, A4VG125 Gear Pump					1
7	W-105787	• • Kit, A4VG125Gear Pump Seal					1
8	W-105788	• • Seal, Shaft					1
9	W-105591	• Assembly, A4VG125 Gear Pump					1
10	W-105785	• • Kit, A4VG125Gear Pump Seal					1
11	W-105786	• • Seal, Shaft					1

DASH (-) ITEM NOT ILLUSTRATED

ITEM NO.	REED'S PARTS NO.	DESCRIPTION					QTY
		1	2	3	4	5	
-1	802242	Assembly, PTO Gear Box (See Group 40, Figure 03 and 04 for NHA)					1
10	802160	• Cylinder, PTO Shift					1
20	802161	• Adapter, Shaft					1
25	802162	• Adapter, Shaft					1
30	802163	• Cap, Packing Ring					2
35	802164	• Flange, Mounting					1
40	802165	• Flange, Mounting					1
50	802166	• Cover					1
55	802167	• Flange, Mounting					1
60	802168	• Gear, Coupling					1
70	802169	• Gear					1
80	802170	• Gear					1
90	802171	• Gear					1
100	802172	• Shaft, Toothed					1
110	802173	• Shaft, Coupling					1
120	802174	• Shaft, Toothed					1
130	802175	• Shaft, Splined Hollow					1
140	802176	• Flange, Mounting					1
150	802177	• Coupling					1
160	802178	• Spacer					1
170	802179	• Adapter, Shaft					1
175	802180	• Ring, Running					2
180	802181	• Flange					2
190	802182	• Housing, Gearbox					1
200	802183	• Fork, Gear					10
210	802184	• Bearing, Ball					1
220	802185	• Bearing, Ball					1
230	802186	• Bearing, Ball					1
240	802187	• Bearing, Ball					2
245	802188	• Bearing, Ball					1
250	802189	• Bearing					1
260	802190	• Bearing, Roller					1
270	802191	• Bearing, Roller					1
280	802192	• Seal, Radial Oil					1
290	802193	• Seal, Radial Oil					1
300	802194	• Seal, Radial Oil					2
310	802195	• O-Ring					1
315	802196	• O-Ring					1
320	802197	• O-Ring					1
330	802198	• O-Ring					1
335	802199	• O-Ring					2

DASH (-) ITEM NOT ILLUSTRATED

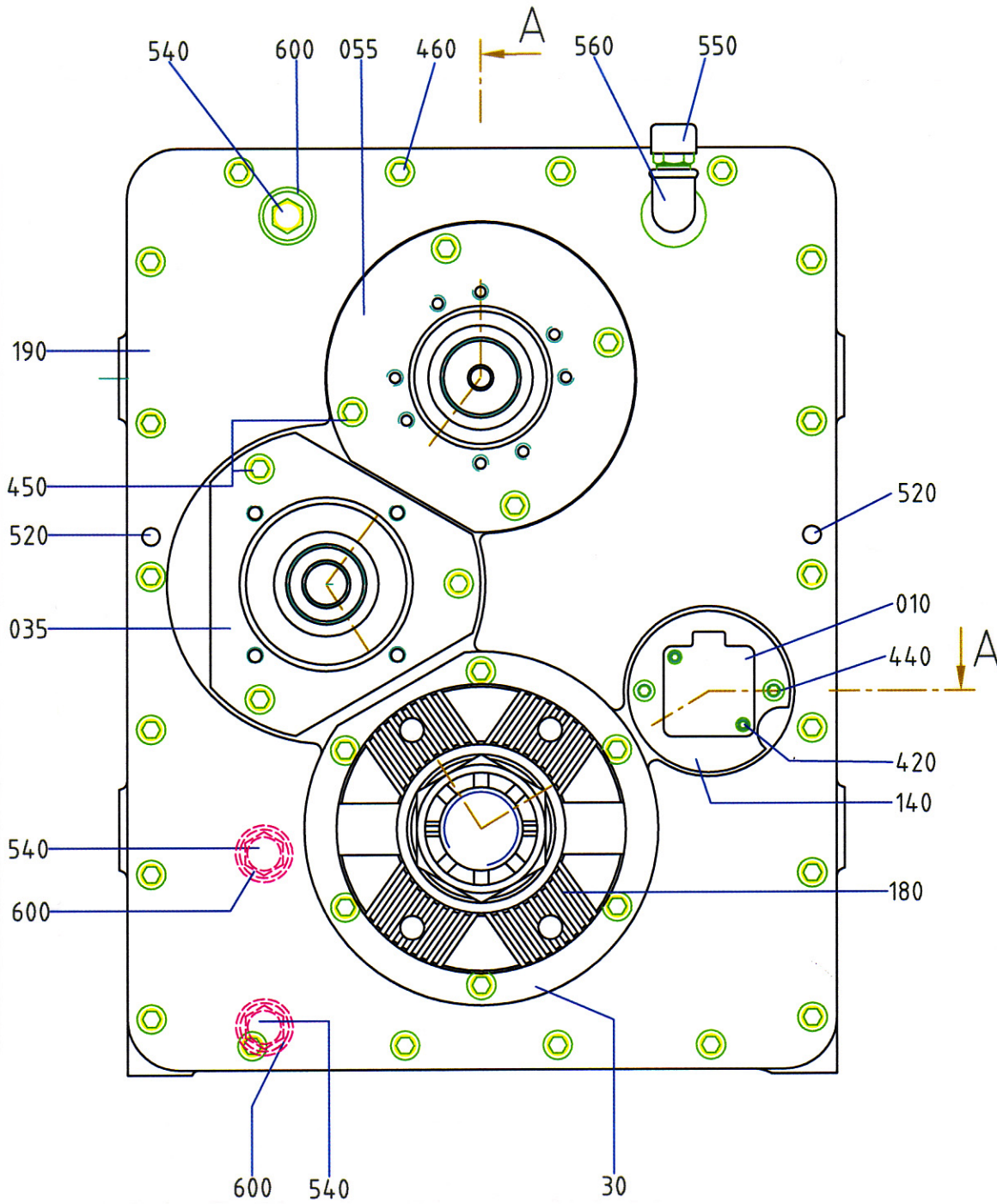

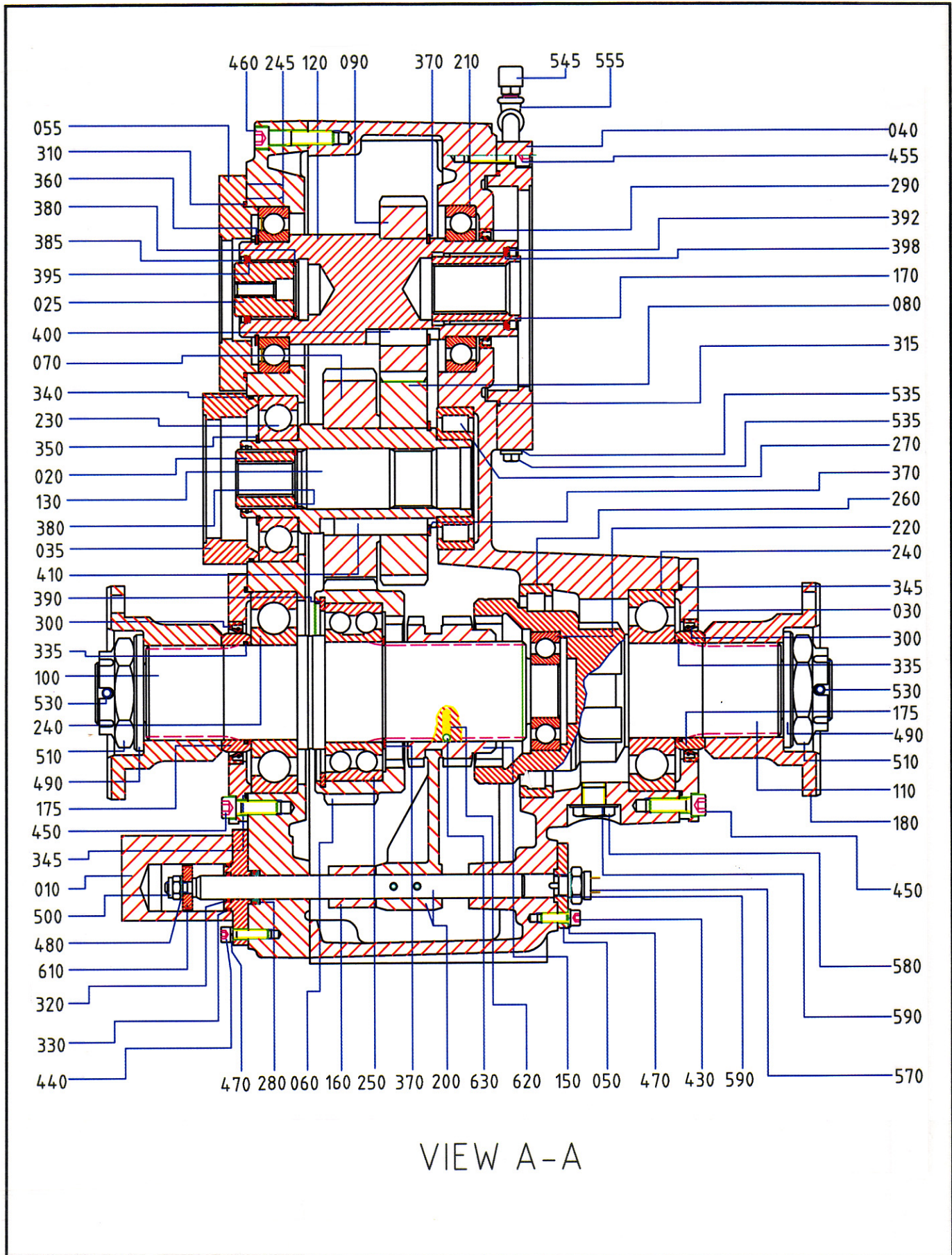

ITEM NO.	REED'S PARTS NO.	1 2 3 4 5	DESCRIPTION	QTY
340	802200	•	O-Ring	1
345	802201	•	O-Ring	2
350	802202	•	Ring, Retaining	1
360	802203	•	Ring, Retaining	1
370	802204	•	Ring, Retaining	3
380	802205	•	Ring, Retaining	2
385	802206	•	Ring, Retaining	1
390	802207	•	Ring, Retaining	1
392	802208	•	Ring, Retaining	1
395	802209	•	Disk, Support	1
398	802210	•	Disk, Support	1
400	802211	•	Key	2
410	802212	•	Key	2
420	802213	•	Screw, Socket Head Cap	2
430	802214	•	Screw, Socket Head Cap	2
440	802215	•	Screw, Socket Head Cap	2
450	802216	•	Screw, Socket Head Cap	19
455	802217	•	Screw, Socket Head Cap	8
460	802218	•	Screw, Socket Head Cap	18
470	802219	•	Washer, Lock	4
480	802220	•	Disk	1
490	802221	•	Disk	2
500	802222	•	Nut, Hex	1
510	802223	•	Nut, Castle	2
520	802224	•	Pin	2
530	802225	•	Pin, Spring	2
535	802226	•	Plug, Hex Head	1
540	802227	•	Plug, Hex Head	3
545	802228	•	Filter, Vent	1
550	802229	•	Filter, Vent	1
555	802230	•	Elbow	2
560	802231	•	Elbow	1
570	802232	•	Switch, Limit	1
580	802233	•	Plug, Hex Head	1
-585	802234	•	Ring, Sealing	1
590	802235	•	Ring, Sealing	2
600	802236	•	Ring, Sealing	3
-605	802237	•	Plug, Screw	2
610	802238	•	Assembly, Piston	1
-615	802239	•	Plug, Screw	1
620	802240	•	Spring	1
630	802241	•	Ball, 1/4 IN	1

DASH (-) ITEM NOT ILLUSTRATED

REED

**MODEL XXT 32 TRUCK MOUNTED
CONCRETE BOOM PUMP
ILLUSTRATED PARTS MANUAL**

**XXT 32
PARTS
GROUP 40
FIGURE 07
PAGE 01**

THIS PAGE INTENTIONALLY LEFT BLANK.