

Waitzinger
Baumaschinen
Vertrieb und
Service GmbH

FREE DIMENSION
TOLERANCE
DIN 7168
MEDIUM

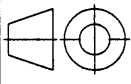

SCALE WEIGHT

DATE NAME
DRAWN 1999/02/05 Mi
CHKD.
APPD.

CONTROL PANEL
Page 1

P12.2a

P12.2a

P12.2b

P12.2b

P12.2

P12.2

/1.8

/3.1

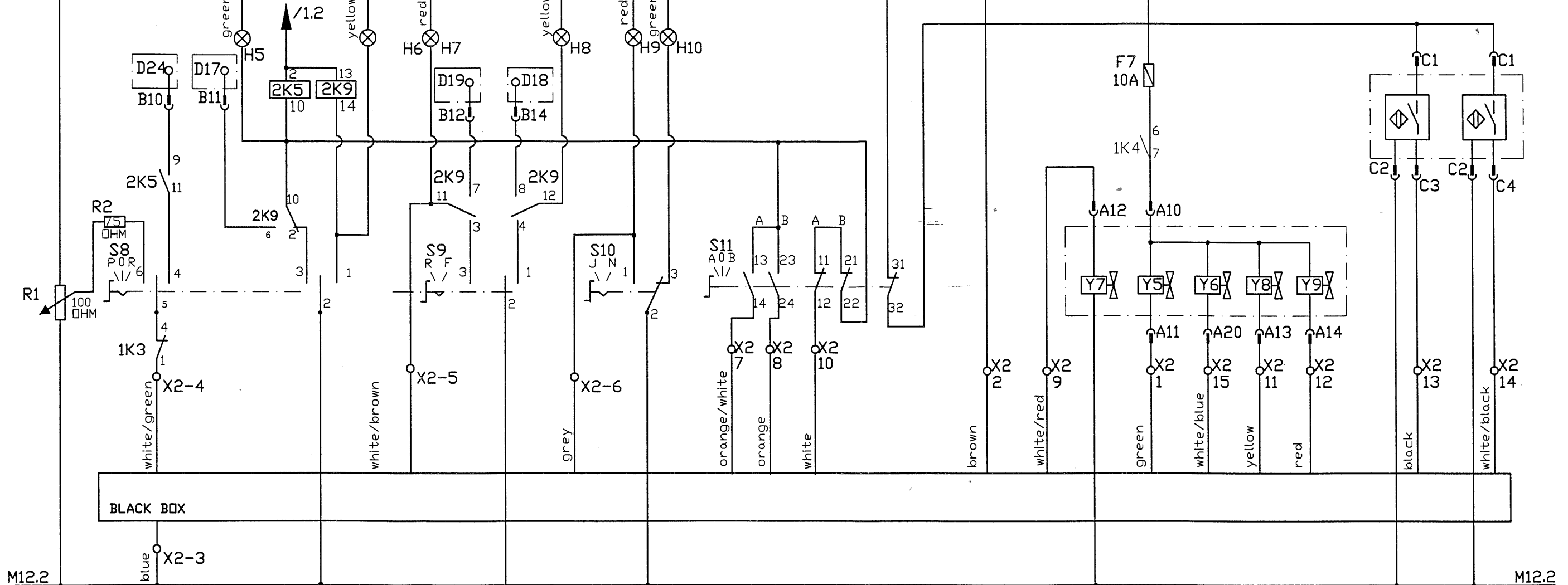

M12.2

M12.2

/1.8

/3.1

POT On/Off/Remote Reverse/Forward Jog/Normal TestCyl.A/Cyl.B Pressure valve Solenoid Hydr.pump Proximity sensors

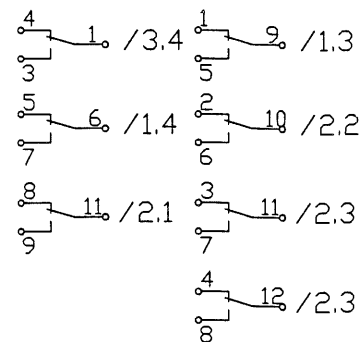

Waitzinger Baumaschinen Vertrieb und Service GmbH	FREE DIMENSION TOLERANCE DIN 7168 MEDIUM		SCALE	WEIGHT
			CONTROL PANEL Page 2	
	DATE	NAME		
	DRAWN 1999/02/05	Mi		
	CHKD.			
	APPD.			

1

2

3

4

5

6

7

8

P12.3a

P12.3b

P12.3 /2.8

P12.3

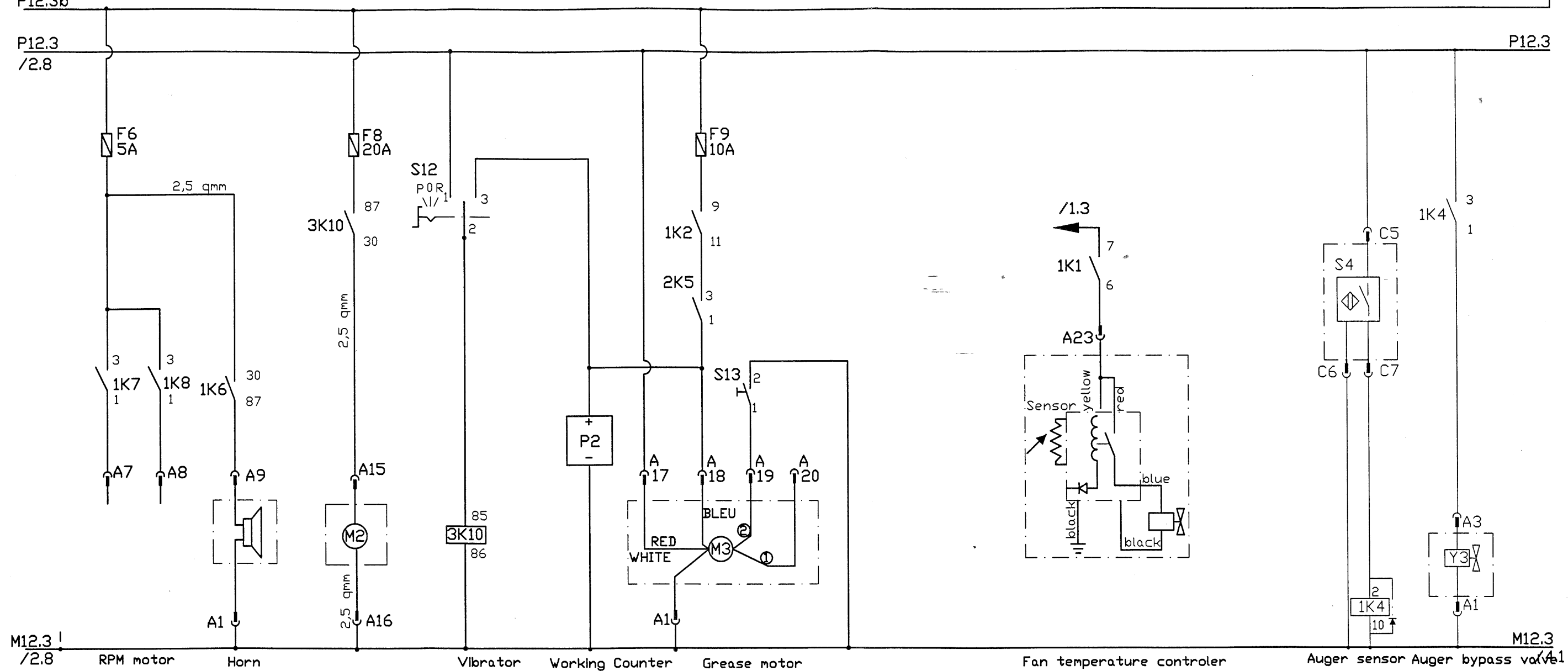

M12.3 /2.8

RPM motor

Horn

Vibrator

Working Counter

Grease motor

Fan temperature controller

Auger sensor Auger bypass valve

M12.3

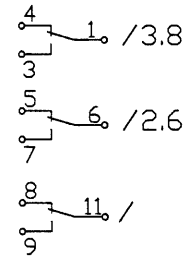
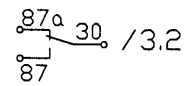

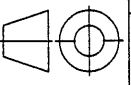
 Waitzinger Baumaschinen Vertrieb und Service GmbH	FREE DIMENSION TOLERANCE DIN 7168 MEDIUM		SCALE	WEIGHT
			CONTROL PANEL Page 3	
	DATE	NAME		
	DRAWN 1999/02/05	Mi		
	CHKD.			
	APPD.			

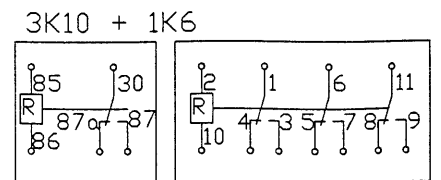
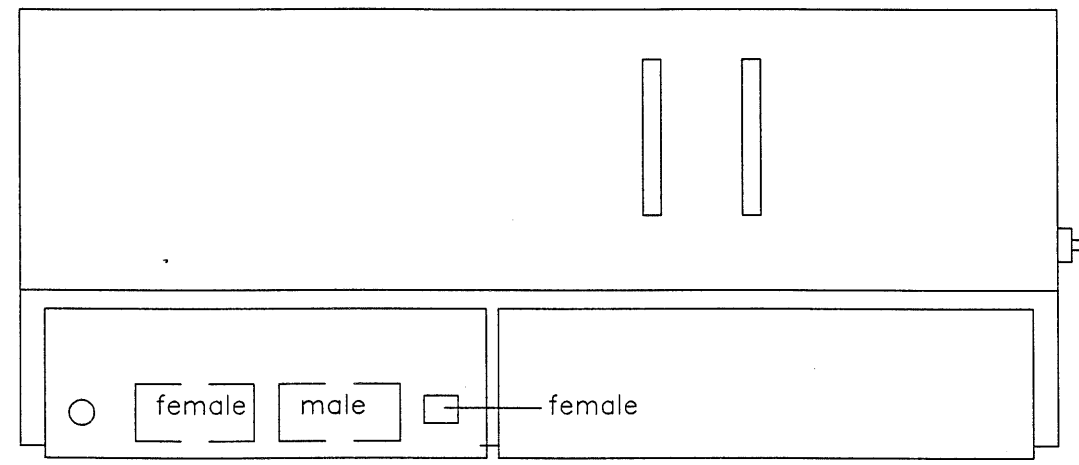
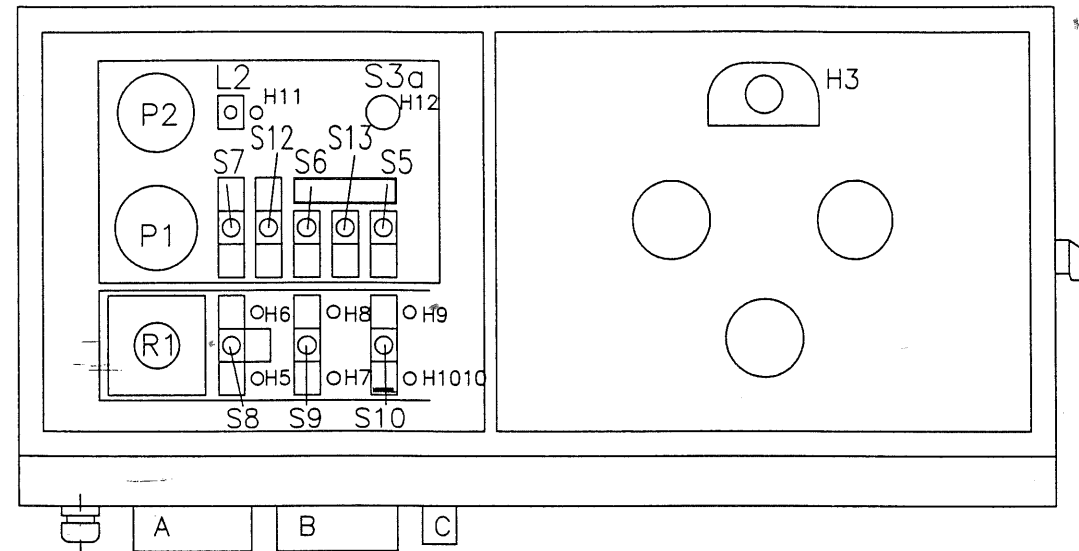
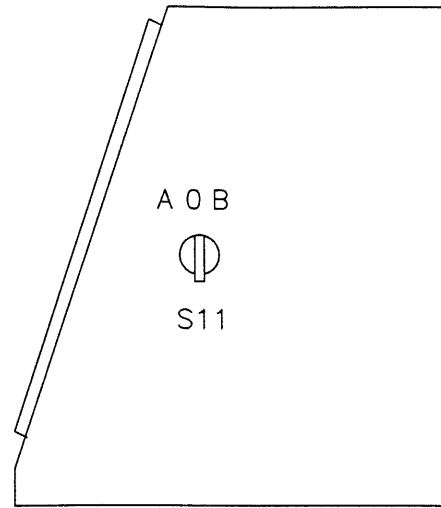
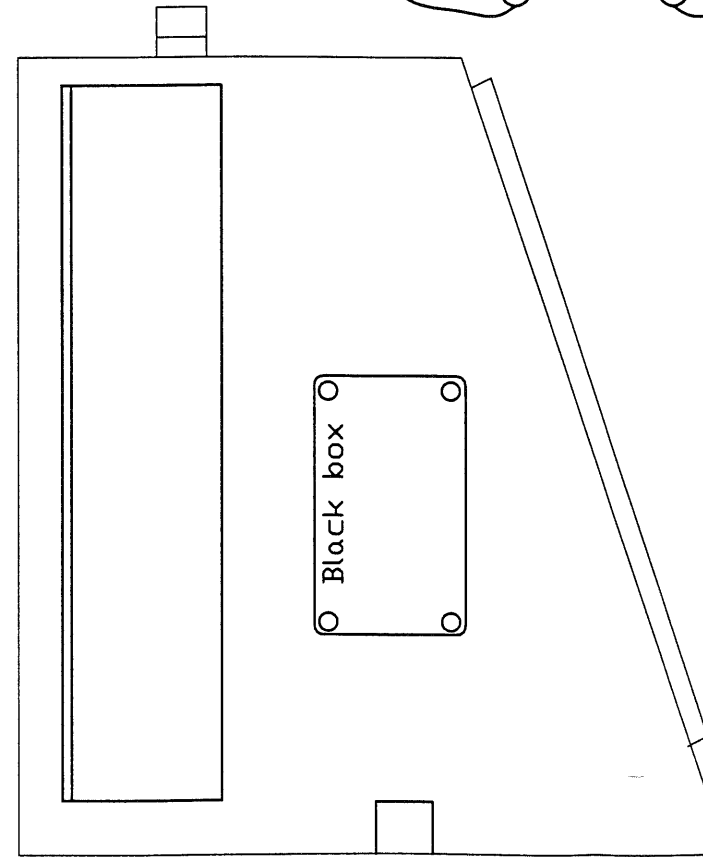
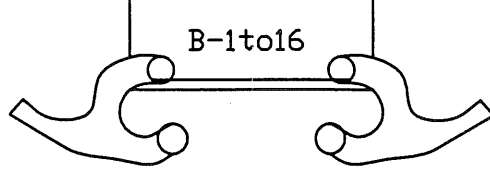
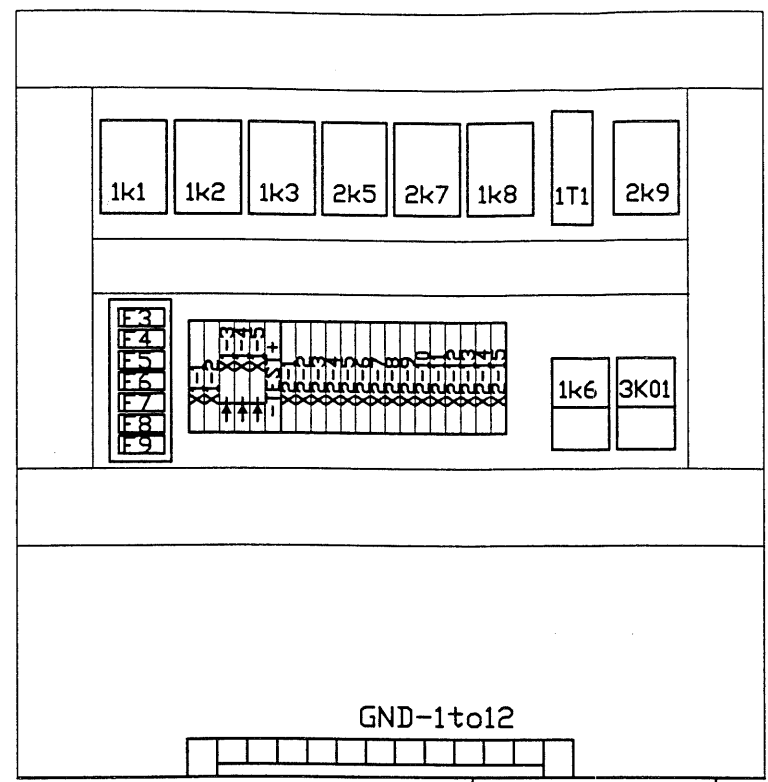

Waitzinger Baumaschinen Vertrieb und Service GmbH	FREE DIMENSION TOLERANCE DIN 7168 MEDIUM		SCALE	WEIGHT
			CONTROL PANEL Page 4	
	DATE	NAME		
	DRAWN 1999/02/05	Mi		
	CHKD.			
	APPD.			

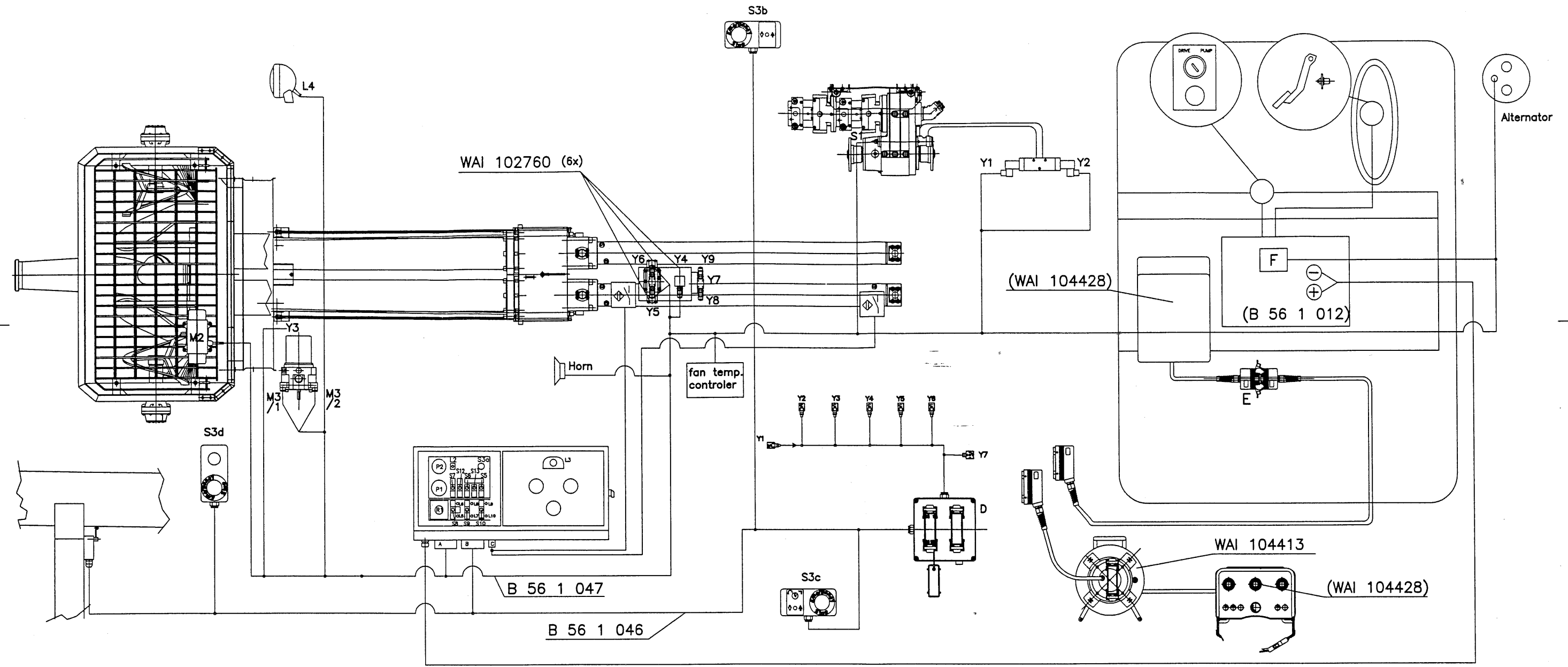

PLUG A

1	Y3+L4+M3/1+ Y4+HORN+Y7+FAN	brn
2	S1>E1	blk/whi
3	Y3-1	red/yel
4	Lima	yel/whi
5	L4	grn/whi
6	Y4-2	blu/whi
7	M1 blue-1	blu
8	M1 brown-2	blk
9	Horn	blk
10	Y5-1/hopper Y6/Y8/Y9	blk/grn
11	Y5- 2	blk/red
12	Y7	gry/red
13	Y8	whi/brn
14	Y9	vio
15	M2	blk
16	M2	blu
17	M3/1 -1	gry
18	M3/1-3	grn
19	M3/2 -2	yel
20	Y6	whi
21		whi
22		whi

PLUG B

1	D10-11	brn	ground
2	S3b	gry	emergency stop
3	S3c	blk	emergency stop
4	S3c	blu	emergency stop
5	D 22	gry/red	emergency stop
6	S3b-d	white	emergency stop
7	D 20	whi/grn	horn
8	D 15	grn	RPM +
9	D 16	blk/whi	RPM -
10	D 24	vio	Pot
11	D 17	blk/grn	pumping on
12	D 19	gry/blk	reverse
13	free	free	free
14	D 18	blu/whi	pumping
15	D 21	blk/red	flashing light
16	D 23	brn/whi	free

PLUG C

pin No.	wire No.	function
1	brown	+
2	blue	-
3	black	Sensor 1
4	black	Sensor 2
5		
6		
7		
8		

PLUG D

pin No.	wire No.	function
1	Y3/3	brn/whi boom 1 up
2	Y3/2	blu boom 1 down
3	Y4/3	grn/whi boom 2 up
4	Y4/2	blk/grn boom 2 down
5	Y5/3	gry/blk boom 3 up
6	Y5/2	blk/whi boom 3 down
7	Y6/3	blk/red boom 4 up
8	Y6/2	gry/red boom 4 down
9	free	free free
10	-11	brn ground
11	Y2/2	vio turn clockwise
12	Y2/3	blu/whi turn anticlockw.
13	S3c	blk/red plus
14	Y1/2/3 Y7	gry pilot valve
15	B 8	grn RPM +
16	B 9	blk/whi RPM -
17	B 11	blk/grn pumping on
18	B 14	blu/whi pumping
19	B 12	gry/blk reverse
20	B 7	whi/grn horn
21	B 15	blk/red free

PLUG E

pin No.	wire No.	function	pin No.	wire No.	function
1	1	power supply 12V	17	34	boom 4 up
2	3	emergency stop	18	31	boom 3 down
3	4	12 V+	19	32	boom 3 up
4	5	RPM-	20	29	turn clockwise
5	6	free	21	30	turn anticlockw.
6	8	horn	22	28	boom 1 down
7	11	RPM+	23	27	boom 1 up
8	13	pump on	24	39	boom 2 down
9	9	GND	25	40	boom 2 up
10	14	reverse	26	-	free
11	25	pilot valve	27	-	free
12	-	free	28	35	pump speed pot
13	-	free	29	-	free
14	-	free	30	-	free
15	-	free	31	-	free
16	33	boom .4 down	32	-	free

TERMINAL F

blk/whi	L1
whi	S1
grn	Y1
gry	Y2
blu	M1 (A7)
blk	M1 (A8)
vio	Lima D
brn	⊖
red	reserve
gry/blk	reserve

Waitzinger Baumaschinen Vertrieb und Service GmbH	FREE DIMENSION TOLERANCE DIN 7168 MEDIUM	SCALE	without	WEIGHT
		own parts list		
DATE	NAME	Cable harness /		
1999/02/11	MI			
DRAWN	CHKD.			

THIS INFORMATION MAY NOT BE COPIED BY A THIRD PARTY. SUBJECT TO COPYRIGHT (PARAGRAF 1 NO. 3 OF JURHEBERRECHTSGESETZ FROM 14.06.1991)

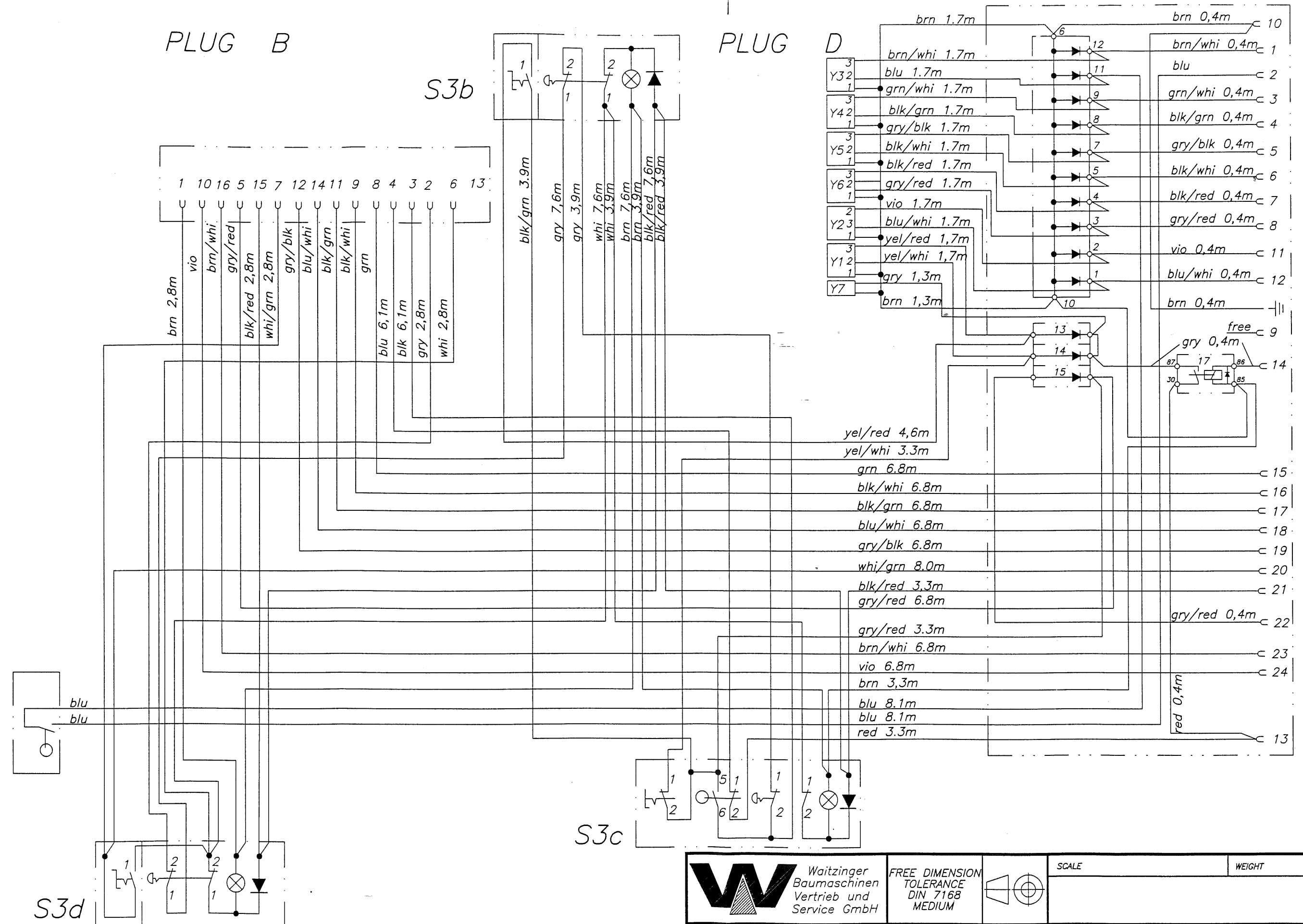

	Waitzinger Baumaschinen Vertrieb und Service GmbH	FREE DIMENSION TOLERANCE DIN 7168 MEDIUM	SCALE	WEIGHT
		DATE	NAME	
		DRAWN 1998/10/05	Fetzer	
		CHKD.		
		APPD.		
Cable harness boom REED				

Lose Teile:
Pos. 59 Kabelbinder 10 Stück

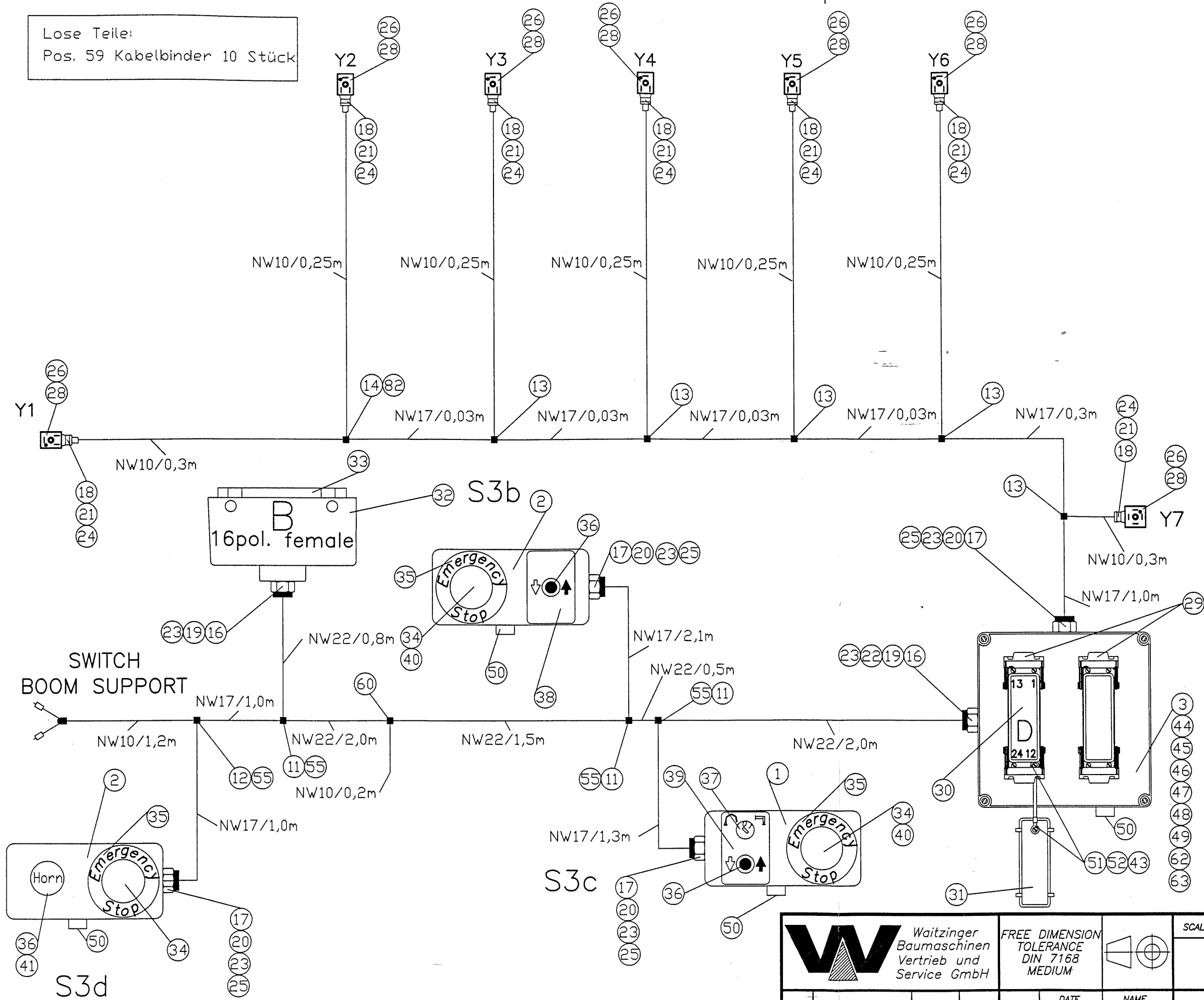

PLUG B

1	D10 -	brn	ground
2	S3b	gry	emergency stop
3	S3c	blk	emergency stop
4	S3c	blu	emergency stop
5	D 22	gry/red	emergency stop
6	free	free	free
7	D 22	whi/grn	horn
8	D 15	grn	RPM +
9	D 16	blk/whi	RPM -
10	D 24	vio	Pot
11	D 17	blk/grn	pumping on
12	D 19	gry/blk	reverse
13	free	free	free
14	D 18	blu/whi	pumping
15	D 21	blk/red	free
16	D 23	brn/whi	free

PLUG D

±	A 1	brn	ground
1	Y3/3	brn/whi	boom 1 up
2	Y3/2	blu	boom 1 down
3	Y4/3	grn/whi	boom 2 up
4	Y4/2	blk/grn	boom 2 down
5	Y5/3	gry/blk	boom 3 up
6	Y5/2	blk/whi	boom 3 down
7	Y6/3	blk/red	boom 4 up
8	Y6/2	gry/red	boom 4 down
9	free	free	free
10	-	brn	ground
11	Y2/2	vio	turn clockwise
12	Y2/3	blu/whi	turn anticlockw.
13	S3c	blk/red	plus
14	Y1/3	gry	pilot valve
15	A 8	grn	RPM +
16	A 9	blk/whi	RPM -
17	A 11	blk/grn	pumping on
18	A 14	blu/whi	pumping
19	A 12	gry/blk	reverse
20	A 7	whi/grn	horn
21	A 15	blk/red	free
22	A 5	gry/red	emergency stop
23	A 16	brn/whi	free
24	A 10	vio	POT

<p>Waitzinger Baumaschinen Vertrieb und Service GmbH</p>	FREE DIMENSION TOLERANCE DIN 7168 MEDIUM	SCALE	WEIGHT
	DATE	NAME	<p>Cable harness boom REED</p>
	DRAWN 1998/10/05	Fetzer	
	CHKD.		
APPD.			

Lose Teile:
 Pos. 35 Halteclip 10 Stück
 Pos. 36 Halteclip 10 Stück
 Pos. 34 Kabelbinder 32 Stück
 Pos. 6 Gegenstecker 3 Stück
 Pos. 27 Flachstecker 6 Stück

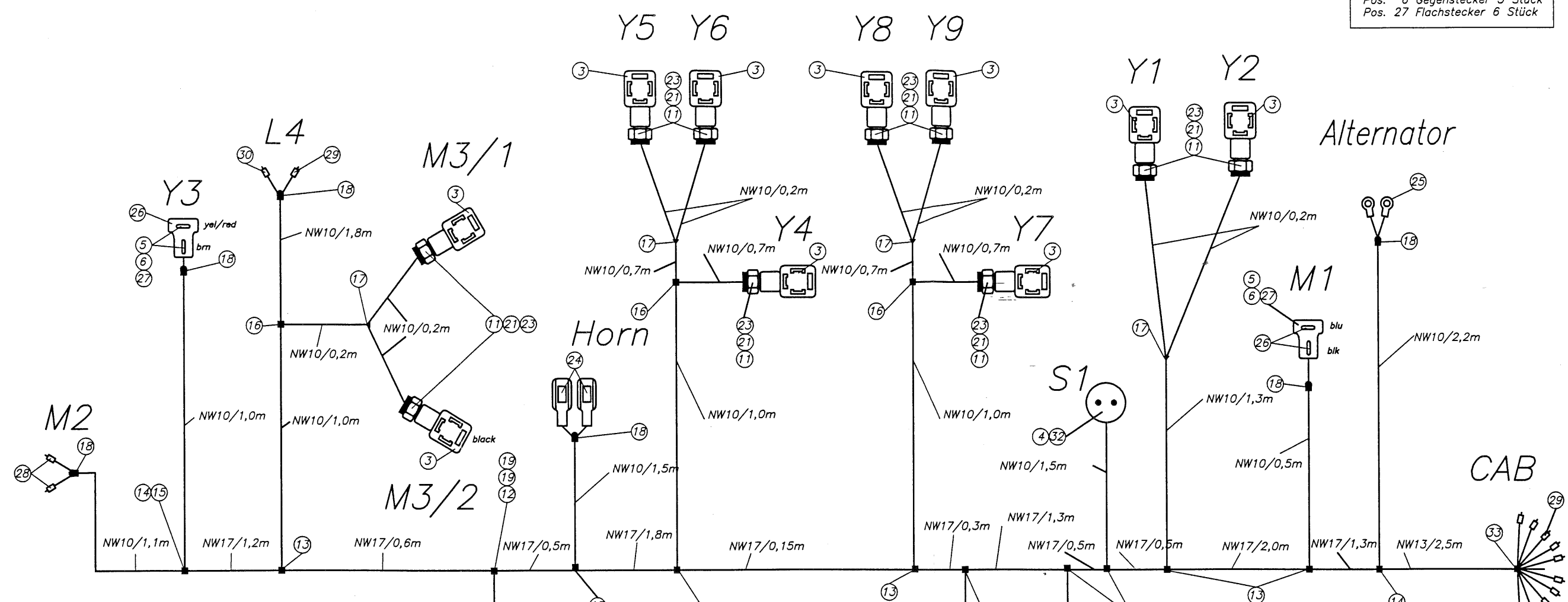

PLUG A

1	Y3+L4+M3/1+Y4+HORN+Y7+FAN	brn
2	S1>E1	blk/whi
3	Y3-1	red/yel
4	Lima	yel/whi
5	L4	grn/whi
6	Y4-2	blu/whi
7	M1 blue-1	blu
8	M1 brown-2	blk
9	Horn	blk 2,5 mm ²
10	Y5-1/hopper/Y6/Y8/Y9	blk/grn
11	Y5-2	blk/red
12	Y7	gry/red
13	Y8	whi/brn
14	Y9	vio
15	M2	blk 2,5 mm ²
16	M2	blu 2,5 mm ²
17	M3/1 -1	gry
18	M3/1-3	grn
19	M3/2 -2	yel
20	Y6	whi
21	•	
22	•	
23	Fan	grn
24	S5	yel/whi

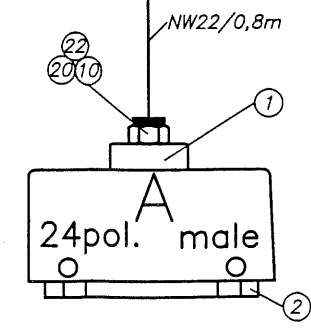



Fan temp. controler

Terminal F

blk/whi	L1
whi	S1
grn	Y1
gry	Y2
blu	M1 (A7)
blk	M1 (A8)
vio	Lima D
brn	⊖
red	reserve
gry/blk	reserve

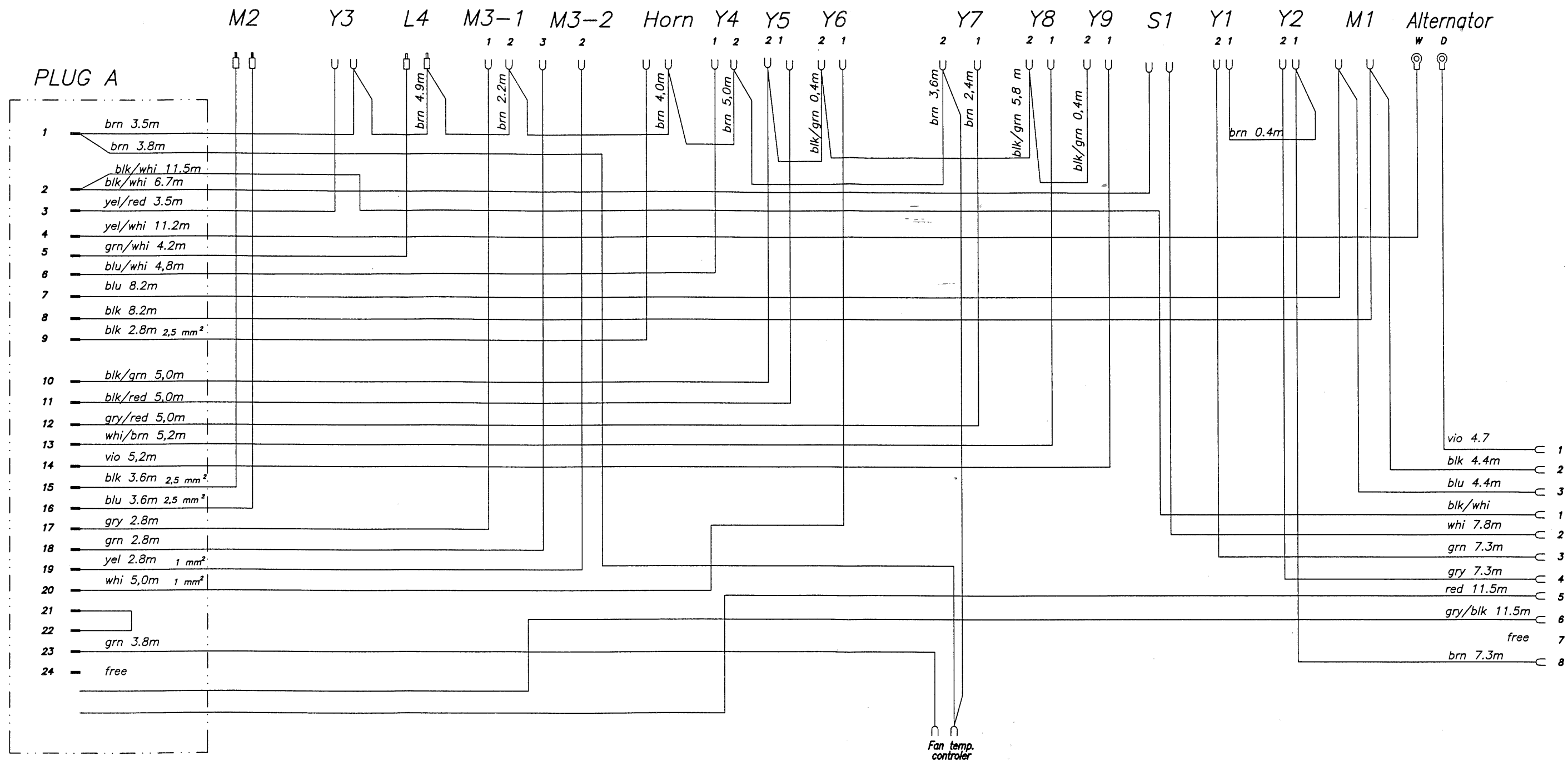
Waitzinger Baumaschinen Vertrieb und Service GmbH	FREE DIMENSION TOLERANCE DIN 7168 MEDIUM		SCALE	WEIGHT
	DATE 1998/05/08	NAME Schies	cable loop pump REED cl 32/36 Mtr.	
DRAWN	APPD.			
CHKD.	APPD.			

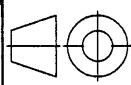

 Waitzinger Baumaschinen Vertrieb und Service GmbH	FREE DIMENSION TOLERANCE DIN 7168 MEDIUM		SCALE	WEIGHT
	DATE 1998/07/13 DRAWN CHKD. APPD.	NAME Mi	cable loop pump REED cl 32/36 Mtr.	