



# OPERATION, MAINTENANCE AND PARTS MANUAL TRUCK - MOUNTED CONCRETE BOOM PUMP MODEL: **XT36R-160**



**REED**, provides this manual for the guidance of all owners, operators and servicing personnel in order to obtain the longest possible trouble-free service. It contains data, specifications, warranty, schematics, operating instructions, lubrication procedures, maintenance procedures, illustrated parts breakdown, vendor information, service bulletins, and safety rules.

Serial No.:

**06-249-XT36R-160**

Date Delivered:

**JUNE 2005**

Customer:

**CASTRO'S CONCRETE**

**NOTE:** Additional copies of this manual may be obtained through the **REED** Parts Department.

**FIRST EDITION: JUNE 10, 2006  
SERIAL NUMBER: 249**



## TRUCK MOUNTED CONCRETE BOOM PUMPS • ONE • TWO • THREE WARRANTY

**REED** warrants each of its new Truck Mounted Concrete Boom Pumps to be free of defects in material and workmanship under normal use and service for a period of One • Two • Three years from date of delivery based on the following conditions:

- One (1) year or 2400 pumping hours whichever comes first
- Two (2) years covering the Solid State Black Box
- Three (3) years covering all structural parts

The **WARRANTY** is issued **ONLY** to the **INITIAL USER**. The warranty periods begins when the product is delivered to the initial user or when first put into service, whichever occurs first. Said warranty is void if the machine is subject to misuse, neglect, accident or abuse.

The **STRUCTURAL WARRANTY** will not be honored unless, regular inspections have taken place and repairs as recommended as a result of the inspection. Inspection guidelines are detailed in the **ACPA BOOM INSPECTION BOOK**, attached in the extreme rear of the **PARTS MANUAL**. The frequency of inspection must adhere to the **ACPA BOOM INSPECTION BOOK**. For **WARRANTY** to be considered valid, these inspections must be performed by a "qualified person" as defined by the **ACPA SAFETY MANUAL**.

**REED'S** obligation under this warranty is limited to correcting without charge, at its factory, any parts or parts thereof which shall be returned to its factory, transportation prepaid and upon **REED'S** examination proves to have been originally defective. Correction of such defects by repair or replacement shall constitute fulfillment of all obligations to the initial user. This warranty does not include labor or transportation charges unless specifically identified and authorized in writing by **REED**. Nor does the warranty apply to any unit upon which repairs or unauthorized alterations have been made.

This warranty does not apply to normal maintenance service or to normal replacement of certain machine parts, which are subject to normal wear (such as concrete cylinders and wear components, valve mechanisms, delivery systems and bracketry, chassis decking / walkways, steps and hand rails, hopper grate, etc.) **REED** makes no warranty in respect to trade accessories or outside vendor components including truck chassis, such being subject to the warranties of their respective manufacturers.

**THIS IS A LIMITED WARRANTY AND IS IN LIEU OF ANY OTHER WARRANTIES, EXPRESSED OR IMPLIED, INCLUDING ANY WARRANTY OF MERCHANTABILITY OR FITNESS FOR A PARTICULAR PURPOSE.** In no event shall **REED** be liable for incidental, general or consequential damages, loss or any expense directly or indirectly related and resulting from use or lack of use caused by delay in delivery, parts failure, or any other causes associated with the product use. No person, firm or corporation is authorized to assume for **REED** any other liability in connection with the sale of **REED** products.

Baugruppenübersicht construction group survey	Betonpumpe: concrete pump:	Mast: boom:
<b>Typenplan</b> <b>type parts list</b>	<b>HP 12523</b>	<b>36R4XT</b>

Kunde: / customer:	<b>REED</b>	Auftrags.-Nr.: / order no.:	<b>204460</b>
Fahrzeug: / vehicle:	<b>Mack 215“</b>	Bestellnr.: / purchase no.:	<b>#07</b>

Zusammenstellung	assemble cpl.	B 00 4 013			
Aufbaurahmen	sub frame	B 01			
Rahmen	base frame	B 02 3 105			
Rahmenverbindung kpl.	frame connection cpl.				
Mastbockverbindung	pedestal connection cpl.	B 03 8 010 a			
Aufbau	housing	B 04			
Abstützung hinten	outrigger cpl.	B 05			
		B 06			
Podeste / Aufstiege	pedestal / ladder	B 07 4 465 a	B 07 4 150 a		
Mastaufgabebock	boom support	B 08 4 185			
Gegengewicht	counter weight	B 09			
Pumpeneinheit kpl.	pump unit cpl.	B 10			
Pumpenlagerung	pump mounting	B 11 4 215			
Förderzylinder kpl.	conveying cylinder cpl.	B 12 4 020			
Förderkolben kpl.	conveying piston cpl.	B 13 3 020			
Spülkasten kpl.	water box cpl.	B 14 3 000			
Antriebszylinder	drive cylinder	B 15 4 032	WAI 106355	WAI 104690	WAI 106354
		B 16			
Schiebersystem	s-valve system	B 17 4 155	Typenplan		
		B			
Zentral / Schmieranlage	central lubrication unit	B 18 3 016			
Förderleitung Aufbau	conveying pipe decking	B 19 8 001			
Kolbensmieranlage	Conveying piston lubrication				
		B 20			
		B 21			
Trichterzubehör	hopper accessories	B 22 4 006			
		B 23			
		B 24			
Rührwerk mit Antrieb	Agitator with drive	B			
		B 27			
Rütteleinrichtung	vibrating equipment	B 28			
		B 29			
Wasseranlage	water system	B 30			
Wassertank kpl.	water tank cpl.	B 31 8 020			
Wasserpumpe mit Antrieb	water pump with drive	B 32 8 010 b	B 32 3 070		
Halter für Wasserschlauch	holder for water hose	B 33 0 020			
Schlauchleitung	hose line	B 34 1 005			
Druckluftanlage	compressed air unit	B 35			
		B 36			
Kompressor mit Antrieb	compressor with drive	B 37			
		B 38			
Schlauchleitung	hose line	B 39			
Hydraulikanlage BP	hydraulic system	B 40 4 010			
Hydrauliks. Pumpe	control block	B 41 4 048 b	B 41 5 002	B 41 4 047	WAI 102741
Hydrauliks. Rührwerk		B 42 4 006 a			
		B 43			
Hydraulikpumpe „S-Welle“	hydraulic pump	B 44 4 030 d	WAI 105847		
		B 45			
		B 46			
Hydrauliktank / Zubehör	hydraulic tank / accessories	B 47 8 010 b			
Ölkühlung	oil cooler	B 48 4 065 c			
Schläuche / Zubehör	hoses / accessories	B 49 4 034			
Elektroanlage	wiring diagram	B 51 3 022 d			
Steuerpult	control panel				
Motorabstellung	engine stop	B 52			
Pumpenverstellung elektrisch	pump adjustment electrical	B 53			
Drehzahlverstellung	rpm adjustment				

Elektroanlage Mast	wiring diagram boom	B 55			
Kabelbaum / Zubehör	wiring harness / accessories	B 56 2 050 b	B 56 2 063	B 56 2 048	
Schaltboxbefestigung	holder for switch box	B 56 1 050			
Spannungswandler	Converter 1 x	WAI 108574			
Kabelfernsteuerung	cable remote control	WAI 107095			
Funkfernsteuerung	radio remote control	WAI 108573			
Verteilmast	distributor boom				
Mastbock	boom support	B 61 8 110	Typenplan		
Befestigung Steuerblock		B 72 1 015			
Transportsicherung	transportation safety device	B 63 1 120c			
Förderleitung	delivery line	B 64 1 011e			
Endschlauchhalter	end hose holder				
Endschlauch	end hose	WAI 101782			
		B 65			
Armpaket ohne Förderleitung	Distributor boom	B 66 1 025	Typenplan		
Kabelbaum Armpaket					
Zentralschmierung					
Hydraulikanlage Mast	hydraulic system boom				
Hydraulikanlage Mast	hydraulic system boom				
Hydraulikanlage Mastbock	hydraulic sys. boom support				
Hydraulikanlage Pumpeinheit	hydraulic sys. pump unit	B 74 1 045 a			
		B 75			
		B 76			
Hydrauliktank Mast	hydrauliktank boom				
		B 78			
		B 79			
Antrieb	drive	B 80			
Verteilergetriebe 4496 1:1,51	distribution gear	B 81 4 090	B 81 4 051a	B 81 4 086	WAI 108412
Antriebsaggregat	engine	B 82			
Wellenstrang	lineshaft	B 83			
Zubehör Beleuchtung	additional parts lightning	B 84			
		B 85			
Trichterbeleuchtung	lightning for hopper	B 86 4 011			
Beleuchtung	lightning	B 86			
Kotflügel	fender	B 87			
Federblockierung	spring lock	B 88			
Achse kpl.	axle cpl.	B 89			
Zubehör	accessories	B 90 3 001			
Standardzubehör	standard accessories	B 91 3 010 c			
Schilder Pumpe	sticker pump	B 92 1 004			
Schilder Mastbock	sticker boom support	B 61 0 050			
Schilder Mast	sicker boom	B 66 0 051			
		B 93			
Werkzeugkasten	tool box	B 94 1 020 d			
Zusatzteile Europa	additional parts europe	B 95			
Rohrmagazin	conveying pipe magazine	B 96			
		B 97			
		B 98			
		B 99			

Bemerkung / comment:

JOB #	XT36-160		SN 06-249
	customer: CASTRO'S CONCRETE		
VL	<b>BOOM MAKE UP PIPE LENGTHS</b>		
8780	ARM		LENGTH
	A		81 1/2"
	B		47 7/8"
	B-C		
	C		47 1/2"
	C-D		
	D		49 7/8"
	E		
	PIPE TYPE		WZ Standard
	TIP HOSE SIZE		
	<b>SPECIAL ELBOWS</b>		PART #
	Turret	A sect	20 5/8" 801102
	A sect	B sect	
	B sect	C sect	27" 801104
	C sect	D sect	
	D sect	E sect	
	<b>DECK MAKE UP PIPE LENGTHS</b>		
	PIPE		LENGTH
	#1		14"
	#2		
	#3		
	SPECIAL ELBOWS		
	TURRET PIPE		35 1/4"
	<b>DECK DELIVERY LINE COMPONENTS</b>		PART #
	HOPPER ELBOW		
	ELBOW 6"		
	REDUCER		
	SPECIAL TURRET ELBOW		
	<b>RADIO REMOTE SERIAL NUMBER</b>		SERIAL #
	RADIO REMOTE		994015599
	CABLE REMOTE		9909349092
	<b>TRUCK</b>		SERIAL #
			IM2K189C45M028204
	<b>BOOM SIZE</b>		SERIAL #
	XT36-160		N-6710

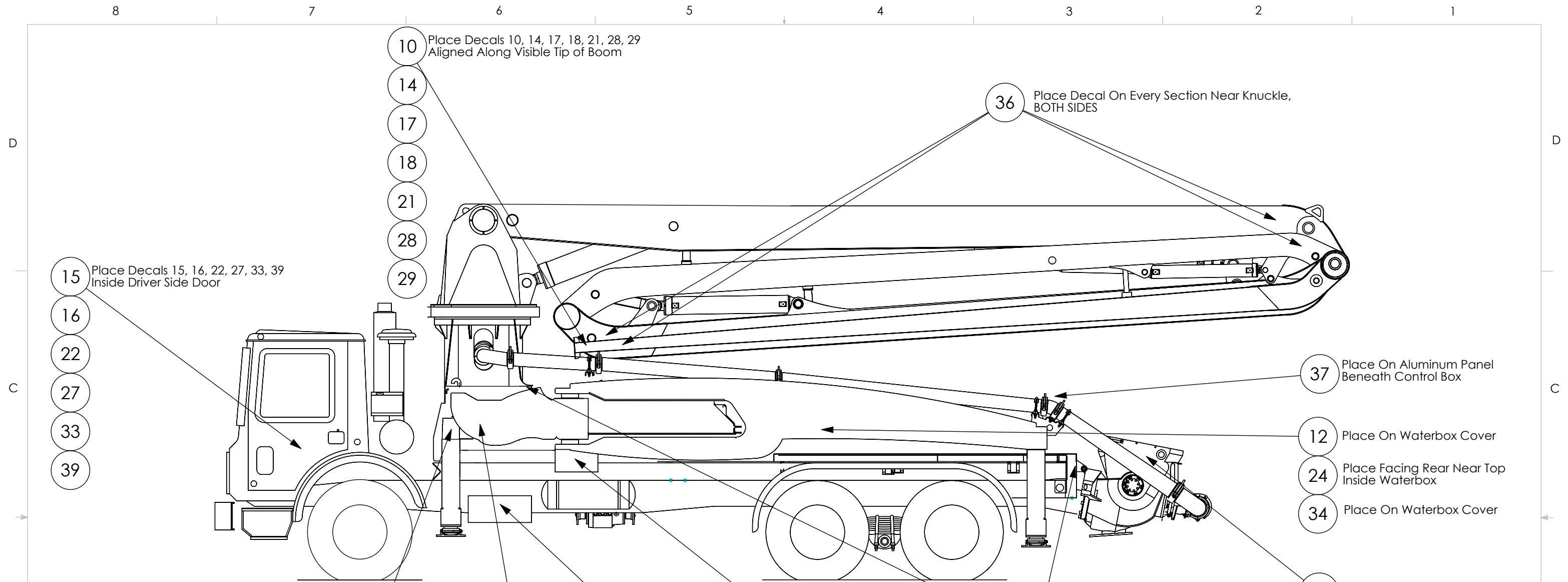

CPMA ID	REED #	REED Description	CPMA Qty
10	803240	Decal, Blockage Hazard	1
11	803223	Decal, Tipping Hazard	2
12	800916	Decal, Waterbox Hazard	1
13	803224	Decal, Do Not Step	2
14	800922	Decal, Reverse Pump	1
15	800925	Decal, Safety Training	3
16	800929A	Decal, Safety Gear	1
17	800921	Decal, Over Pressure Hazard	1
18	800923	Decal, Retaining Pins	1
19	800919	Decal, Crushing Hazard	4
20	803225	Decal, Leaks Hazard	8
21	800928	Decal, Boom Crack Hazard	1
22	803226	Decal, How to Order	1
23	800918	Decal, Agitator Hazard, Foot	2
24	803227	Decal, Missing Guard	1
25	800917	Decal, Agitator Hazard, Hand	2
26	803228	Decal, Off Platform	4
27	803229	Decal, CPMA	1
28	803230	Decal, Starting Discharge	1
29	800927	Decal, Not a Crane	1
30	803231	Decal, Toxic Dust	2
31	800915	Decal, Stay Clear	4
32	803232	Decal, Extending Outrigger	2
33	803233	Decal, Safety Instructions	1
34	800924	Decal, Remote Control	1
35	803234	Decal, Outriggers	2
36	800913	Decal, 17Ft Hazard	8
37	800930	Decal, 1-14 Op Signals	1
38	803235	Decal, 1-7 Op Signals	0
39	803236	Decal, CPMA	1
40	803237	Decal, Pressurized Pipes	25
41	803238	Decal, Pressurized Hoses	25
42	803239	Safety Tags	25

**NOTES**  
 1. Place Decals 40, 41 Next To Clamps ON ALL Straight Pipe  
 2. Place Decal 42 ON ALL Clamps

REV	DATE	DESCRIPTION OF CHANGE	BY	DRAWN	CT	0606
REVISION						

DO NOT SCALE DRAWING  
 UNLESS OTHERWISE SPECIFIED  
 DIMENSIONS ARE IN INCHES  
 TOLERANCES:  
 FRACTIONAL ± 1/16  
 XX ± .031  
 XXX ± .010  
 ANGULAR: MACH ± 1 BEND ± 1  
 BREAK ALL SHARP EDGES  
 .010 MAX x 45  
 ALL MACHINED SURFACES  
 UNLESS OTHERWISE SPECIFIED

<b>REED</b>		CONCRETE PLACING EQUIPMENT CHINO, CA 91710	
TITLE <b>Decal Legend</b>			
MATERIAL		MATERIAL	PART NUMBER
			<b>803243</b>
THIS DRAWING IS THE PROPERTY OF REED MANUFACTURING AND IS LOANED WITHOUT CONSIDERATION OTHER THAN THE BORROWERS AGREEMENT THAT IT SHALL NOT BE REPRODUCED, COPIED, LOANED, OR DISPOSED OF, DIRECTLY OR INDIRECTLY, NOR USED FOR ANY PURPOSE OTHER THAN THAT FOR WHICH IT IS SPECIFICALLY FURNISHED.			REV.
			<b>SHEET 1 OF 1</b>



## Premessa

- Nel lavoro di compilazione del manuale si è cercato di mettere in particolare evidenza gli aspetti legati alla salvaguardia della sicurezza. Infatti, consultando le istruzioni per l'uso o le istruzioni per la manutenzione, si potrà notare che la descrizione dei comandi per l'utilizzo della macchina viene proposta in associazione con l'illustrazione dei pericoli o delle manovre pericolose. Si sottolinea quindi l'importanza di consultare con attenzione ogni argomento trattato nelle sezioni relative all'uso ed alla manutenzione, che hanno lo scopo di fornire all'operatore le istruzioni necessarie ed essenziali per un perfetto funzionamento del braccio e perchè rimangano immutate nel tempo le caratteristiche di prestazioni e di efficienza.
- La ditta *Waitzinger*, con il presente manuale intende fornire anche gli elementi tecnici e di calcolo per una corretta installazione dei propri bracci per calcestruzzo. Si premette che verranno trattati solo i casi più generali. Per installazioni particolari, e per meglio comprendere le direttive di seguito descritte, si consiglia di interpellare i nostri tecnici.
- Il manuale si completa con la descrizione di tutti i componenti e degli organi di controllo, attraverso l'illustrazione del loro funzionamento con schemi elettroidraulici e consigli per la loro manutenzione.
- L'allestitore deve fare riferimento, oltre alle presenti direttive, a tutte le prescrizioni antinfortunistiche vigenti relative ai lavori di officina e alla

## Preface

- Whilst compiling this manual particular importance has been given to the question of protection and safety at work. This can be noted, when consulting the instructions for use or the maintenance instructions, by the fact that the description of the controls for the use of the machine is presented together with a summary of the dangers or the potentially dangerous maneuvers. This underlines the importance of carefully consulting each of the topics dealt with in the relative use and maintenance sections, aimed at providing the operator with all the necessary and essential instructions for the perfect operation of the boom, and in order to ensure that the performance and efficiency of the machine remain unaltered with the passing of time.
- With this manual the *Waitzinger* company also intend to provide the calculations and technical information required for the correct installation of their concrete distributor booms. It should be underlined that only general cases will be dealt with. For special installations, and in order to better understand the guidelines described hereafter, it is advised to contact our technical office.
- The manual concludes with a description of all the components and organs of control, with electro-hydraulic diagrams illustrating their function and advice for maintenance operations.
- Together with the instructions contained in this manual, the fitter must also make reference to the accident prevention regulations in relation to



## SEZIONE A descrizione macchina

## SECTION A general description

movimentazione dei carichi.

workshop activities and load handling.

### Garanzia

- Tutti i bracci *Waitzinger* vengono sottoposti in fabbrica ad un severo ciclo di collaudo e vengono consegnati all'Utente con tutti i dispositivi di controllo opportunamente tarati e muniti di piombatura di garanzia.
- E' severamente vietato manomettere i sigilli di taratura.
- La nostra Ditta è sempre a disposizione per fornire chiarimenti e consigli all'Utente onde assicurare la migliore efficienza dell'attrezzatura.  
Per quelle operazioni che non fossero facilmente eseguibili con i mezzi di cui normalmente dispone il Cliente, la Ditta provvederà per la migliore assistenza a mezzo di informazioni tecniche e con attrezzature studiate per tale servizio.
- Si raccomanda l'uso di parti originali per i ricambi necessari allo scopo di ottenere risultati migliori e di conservare al braccio le caratteristiche tecniche e costruttive originali; la non osservanza di quanto sopra, provoca la decadenza immediata dei benefici di garanzia.
- La durata del periodo di garanzia è di 6 mesi dalla data di consegna del braccio ai Clienti, documentata dall'invio alla casa costruttrice dell'apposito **CERTIFICATO DI GARANZIA**.  
Le condizioni generali di garanzia sono riportate nel suddetto certificato accompagnatorio.

**In caso di manomissione dei sigilli delle valvole di sicurezza non è concessa più nessuna forma di garanzia.**

### Warranty

- All *Waitzinger* booms are subject to rigorous tests before leaving the factory and are supplied to the customer with all control mechanisms appropriately calibrated and fitted with guarantee lead seals.
- Tampering with these calibration seals is strictly prohibited.
- The *Waitzinger* company remain at the Customer's disposal for explanations and advice in order to ensure optimal machine efficiency.  
For operations that cannot be carried out with the customer's standard equipment, the company will provide detailed technical information and specially designed equipment for this purpose.
- Always use original spares for the eventual replacement of parts.  
This will help to achieve the best results and maintain the original technical and construction specifications of the boom. Failure to do so will result in the immediate annulment of the warranty.
- The machine is guaranteed for a period of 6 months from the delivery date of the boom to the customer, documented by the sending of the **WARRANTY CERTIFICATE** to the manufacturers.  
The general warranty conditions are noted on this certificate.

**If the safety valve seals have been tampered with, the warranty will be considered to be canceled.**





## Funzione dei componenti

Il braccio per calcestruzzo è una attrezzatura articolata, a funzionamento elettroidraulico, atta alla distribuzione del calcestruzzo su tutto il campo operativo indicato nello schema. Tale attrezzatura è composta dai seguenti gruppi:

- **Gruppo elementi del braccio**  
Tale gruppo è formato da quattro elementi a sezione rettangolare e di opportune dimensioni lineari.  
Questi elementi sono tra loro incernierati alle estremità ed il relativo moto è dato da cinematismi azionati da martinetti idraulici. L'ultimo elemento porta il tubo terminale flessibile della condotta calcestruzzo. Lungo i quattro elementi sono fissati i supporti della condotta calcestruzzo, costituita da tubi di varie lunghezze, e curve a novanta gradi.  
Il primo elemento è incernierato al gruppo testata ed è azionato da un martinetto idraulico, senza cinematismo.
- **Incastellatura**  
Tale gruppo è la base di supporto del braccio e viene collegato con giunzioni saldate ad un controtelaio.  
Nella incastellatura vengono installati i serbatoi dell'olio per il braccio, olio e acqua per la pompa calcestruzzo, e il gruppo degli stabilizzatori.
- **Gruppo testata girevole**      Tale gruppo collega per mezzo di una cerniera il primo elemento del braccio. La testata girevole è avvitata al cuscinetto di base.
- **Gruppo rotazione**  
Questo gruppo consente la rotazione della testata e quindi del braccio.  
Esso è costituito da un cuscinetto di rotolamento con dentatura sull'anello esterno: l'anello è fissato alla base superiore dell'incastellatura, mentre sull'anello esterno viene fissato il gruppo

## Component operation

The concrete distributor boom is an electro-hydraulically operated articulated mechanism, designed for concrete distribution throughout the operative field of the machine indicated in the diagram. The equipment is made up of the following units:

- **Boom elements unit**  
This unit is composed of four rectangular-shaped elements, with appropriate linear dimensions.  
These elements are hinged together at the ends and operated by hydraulic jack activated kinematic mechanisms.  
The final element houses the concrete distributor flexible end hose.  
The concrete delivery pipe supports, composed of pipes of different lengths and quarter elbow curves, are fitted along the length of the four elements. The first element is hinged to the head unit and is operated by a hydraulic jack, without a kinematic mechanism.
- **Support frame**  
This unit forms the support base of the boom and is attached to a counterframe by means of welded joints.  
The boom oil tank, the concrete pump oil and water tanks and the stabilizers unit are all positioned on the support frame.
- **Rotating head unit**  
This unit connects the first boom element by means of a hinge.  
The rotating head is screwed onto the base bearing.
- **Rotation unit**  
This unit allows the head unit, and therefore the boom, to rotate.  
It is made up of a rolling bearing with tothing on the outer ring: the ring is attached to the upper base of the support frame, whereas the head unit is attached to the outer ring.



## SEZIONE A descrizione macchina

## SECTION A general description

testata.

- La dentatura esterna ingrana con il pignone del riduttore.  
Un anello eccentrico inserito tra incastellatura e riduttore consente la regolazione del gioco tra pignone e ralla.  
Il riduttore è fissato sul gruppo castello ed è azionato da un motore idraulico.
- **Stabilizzatori anteriori**  
Gli stabilizzatori anteriori, muniti di elementi telescopici orizzontali, sono incorporati nell'incastellatura e sfilano per mezzo di martinetti idraulici fino alla posizione di lavoro.
- **Stabilizzatori posteriori**  
Gli stabilizzatori posteriori, girevoli, sono incorporati nel controtelaio e vengono azionati da martinetti idraulici.  
La posizione degli stabilizzatori anteriori e posteriori durante il lavoro viene assicurata da valvole di bloccaggio.
- **Quadro comandi**  
Tutti i movimenti vengono effettuati idraulicamente. Sui martinetti del braccio vengono installate speciali valvole di non ritorno pilotate, con funzione di limitazione della pressione. Le leve di comando del distributore idraulico integrato ai movimenti del braccio, sono azionate elettricamente, a distanza mediante telecomando (il radiocomando è opzionale). Nel caso di avaria dei dispositivi del comando a distanza è ugualmente consentita la manovra mediante le leve situate sul gruppo comandi posizionato sul lato destro alla base dell'incastellatura. Dai posti di comando, l'operatore è in grado di vedere tutte le indicazioni necessarie per effettuare i movimenti del braccio e stabilizzatori, ed è in grado di assicurarsi della eventuale presenza di persone all'interno del campo operativo. Anche sui martinetti degli stabilizzatori vengono installate le valvole di non ritorno pilotate. Il movimento degli stabilizzatori è
- The outer ring meshes with the reduction unit pinion. An eccentric ring, inserted between the support frame and the reduction unit, allows the play between the pinion and the fifth wheel to be adjusted. The reduction unit is attached to the turret unit and is operated by a hydraulic motor.
- **Front stabilizers**  
The front stabilizers, fitted with horizontal telescopic elements, are incorporated in the support frame and extend to the required working position by means of hydraulic jacks.
- **Rear stabilizers**  
The slewing rear stabilizers are incorporated in the support frame and are operated by hydraulic jacks.  
The secure position of the front and rear stabilizers during working operations is safeguarded by a lock valve.
- **Control panel**  
All movements are carried out hydraulically. Special piloted check valves have been positioned on the boom jacks as pressure limiting devices.  
The hydraulic distributor, integrated with the boom movement, control levers are electrically operated by means of a handset (the radio control is optional).  
In the event of remote control equipment failure, maneuvers can still be carried out by means of the levers, fitted on the control unit, located on the right hand side at the support frame base.  
From the control positions the operator is able to visually verify all the necessary conditions for boom and stabilizer movement, and will be capable of checking the eventual presence of personnel within the operative field of the machine. Piloted check valves have also been fitted on the stabilizer jacks. Stabilizer movement can only be carried out by means of the levers positioned on



consentito soltanto attraverso le leve dei gruppi di comando posti sui lati destro e

sinistro della macchina.

Il consenso per il comando viene dato da un interruttore elettrico.

Entrambi i comandi sono provvisti di dispositivo “uomo morto”.

- **Arresto d'emergenza**

La macchina è provvista di due dispositivi di arresto elettrici “EMERGENCY-STOP” disposti sia sul quadro comandi manuali, collocato sull'incastellatura, che sulla scatola del comando a distanza (telecomando o radiocomando).

Nel caso di avaria dei dispositivi elettrici di arresto descritti, lo sblocco del dispositivo è possibile solo con una manovra meccanica dal distributore idraulico a bordo macchina, che non avvia la macchina ma consente al sistema la funzione di emergenza.

## **Dati di identificazione**

La targhetta di identificazione della macchina (*figure sotto*) è fissata sulla incastellatura e riporta i seguenti dati: anno di fabbricazione, modello della macchina e numero di matricola, diametro della tubazione di mandata e lunghezza del tubo terminale flessibile, pressione oleodinamica di esercizio e il tipo di olio per l'impianto.

Il numero di matricola viene stampigliato anche sul basamento, in prossimità della targhetta.

the right and left hand sides of the machine.

Control consensus is given by means of an electrical switch.

Both controls are fitted with a “dead man's handle” device.

- **Emergency stop**

The machine is provided with two electric “EMERGENCY STOP” devices, positioned both on the manual control panel (located on the support frame) and on the handset control panel (remote or radio control).

In the event of failure of the aforementioned electrical devices, the mechanism can only be released by mechanically maneuvering the hydraulic distributor on the machine.

This does not start the machine, but allows the system to operate in emergencies.

## **Identification data**



The machine identification plate (*see figure below*) is attached to the support frame and provides the following information: year of manufacture, machine model and serial number, delivery pipe diameter and flexible end hose length, hydraulic operating pressure and the type of fluid used in the system.

The serial number is also printed on the base, near the plate.



**SEZIONE A**  
*descrizione macchina*

**SECTION A**  
*general description*

		Waitzinger Baumaschinen Vertrieb & Service GmbH Neu-Ulm / Germany			
Modell Model	<input type="text"/>	Zul. Gesamtgewicht (kg) Total weight perm. (kg)	<input type="text"/>		
Maschinen Nr. Masch.-No.	<input type="text"/>	Zul. Achslast (to.) Axle weight perm. (to.)	<input type="text"/>		
Baujahr Year of construction	<input type="text"/>	max. Abstützdruck (kp) max Outriggers press. (kp)	<input type="text"/>		
max. Hydraulikdruck max. Hydr. pressure	<input type="text"/>	max. Betondruck (bar) max. Concrete press. (bar)	<input type="text"/>		
V max. (km/h)	<input type="text"/>	max. Drehzahl max. rpm	<input type="text"/>		
WAI106179					

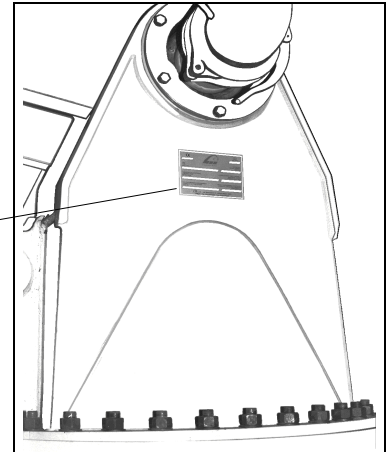

**Campo operativo**

**Operative field of the machine**

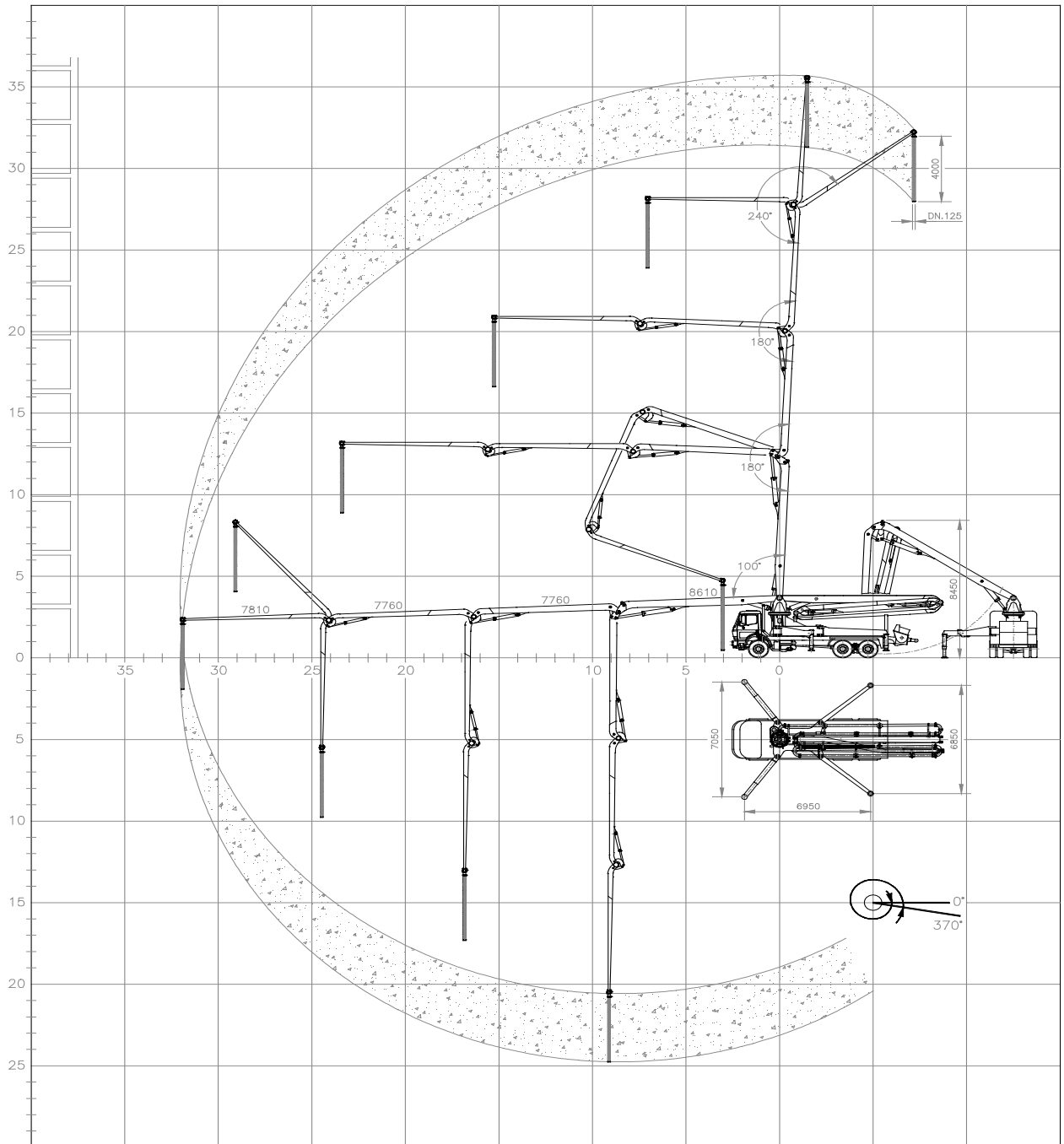

Questo schema del campo di lavoro, dal quale è possibile trarre in modo rapido tutte le informazioni relative ai movimenti degli elementi del braccio, viene riportato anche sulla macchina applicato su una targhetta.

This machine operative field diagram, which briefly provides all of the information concerning the movement of the boom elements, is also attached to the machine on a plate.



**SEZIONE A**  
*descrizione macchina*

**SECTION A**  
*general description*

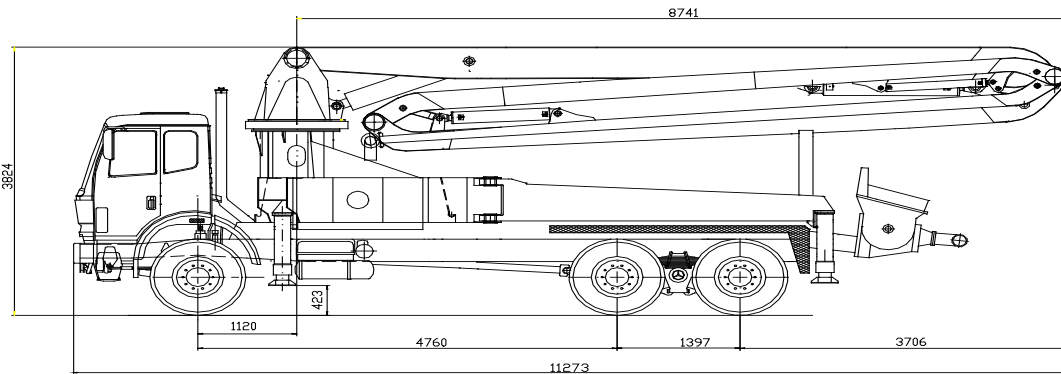

**Lato sinistro macchina**

**Left hand side of machine**

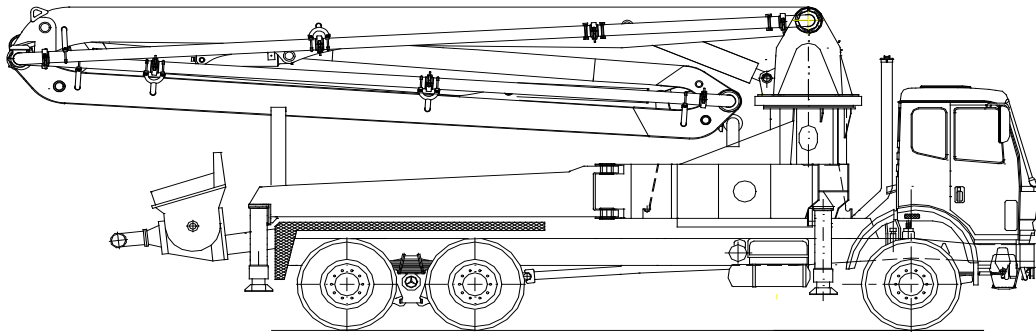

**Lato destro macchina**

**Right hand side of machine**

**Dimensioni e pesi**

**Dimensions and weights**

**SEZIONE A**  
*descrizione macchina*

**SECTION A**  
*general description*

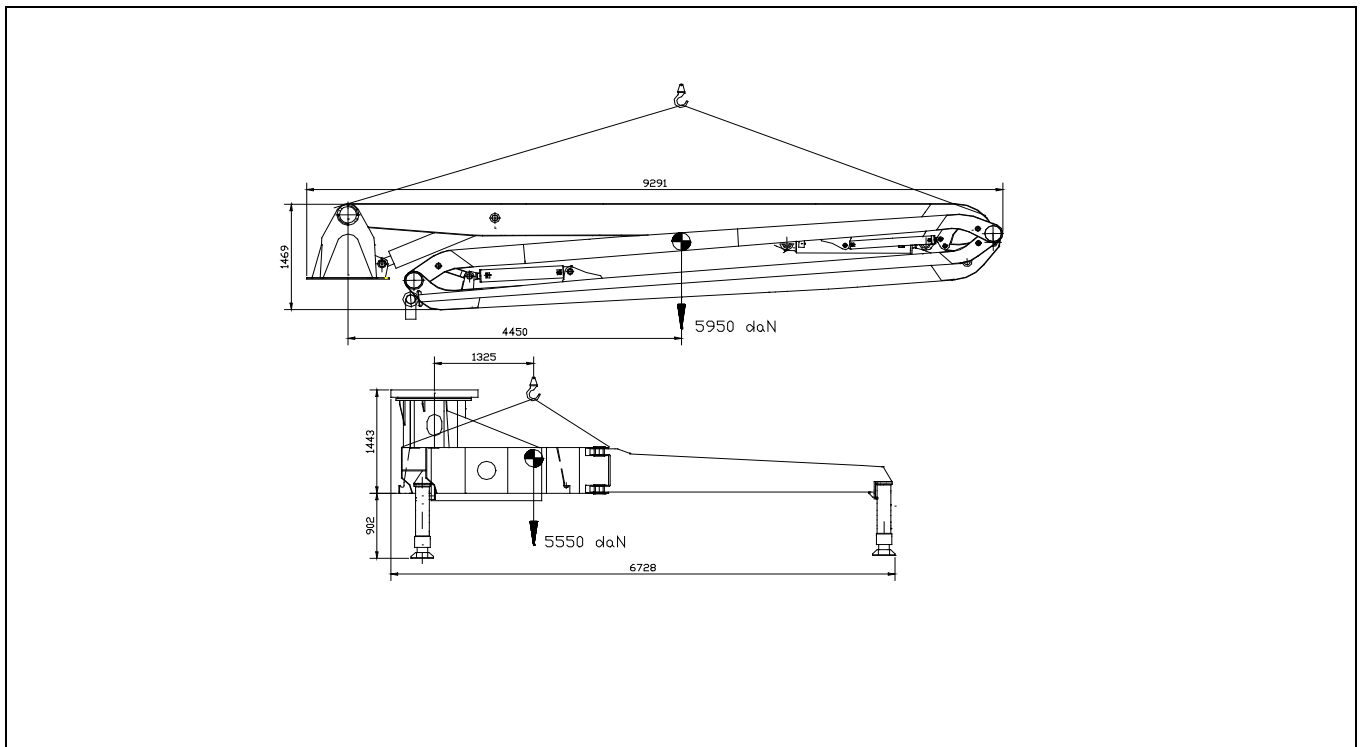
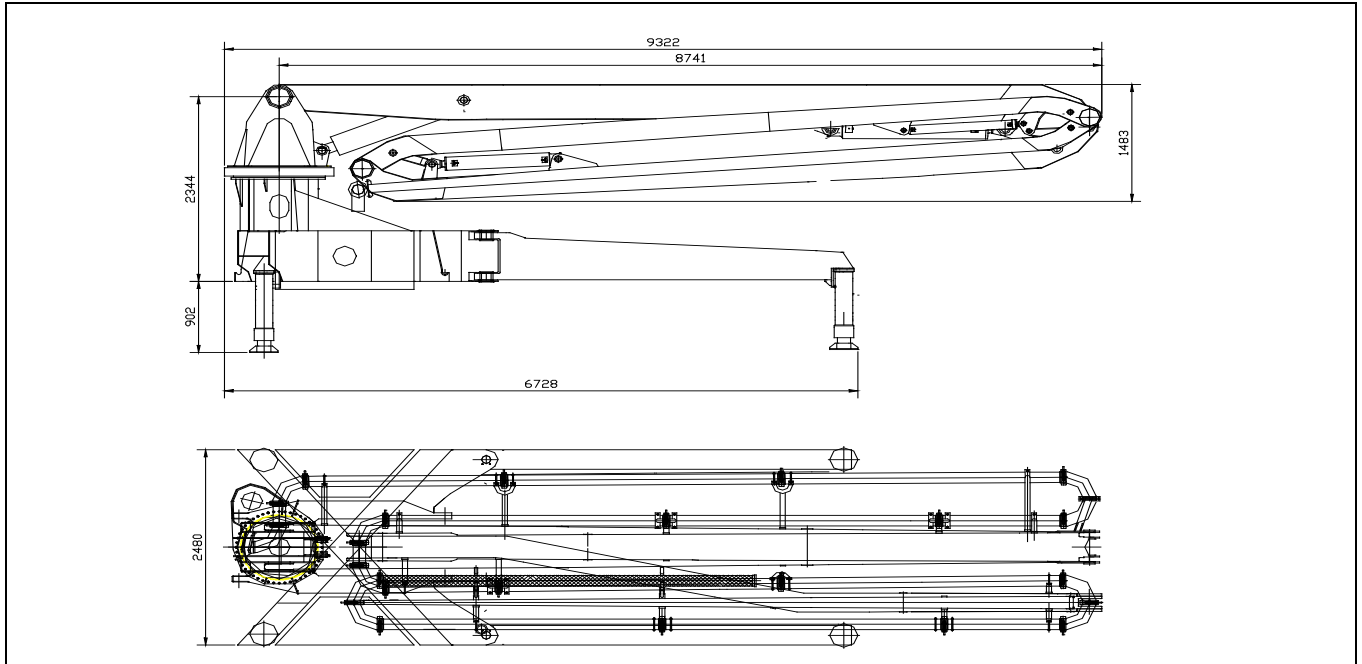

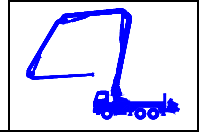

## Prima dell'uso

Leggere questa sezione del manuale prima di eseguire qualsiasi operazione !

Questa parte contiene informazioni importanti che è necessario conoscere per poter usare correttamente l'unità ed inoltre essa aiuta a familiarizzare con i vari comandi e funzioni, sul significato delle indicazioni, su come effettuare le regolazioni e altre informazioni importanti.

Prestare inoltre particolare attenzione alle regole generali di sicurezza.

Ricordiamo infine che il presente libretto deve essere tenuto a portata di mano per poter essere visionato in qualsiasi momento sul luogo di utilizzo dell'attrezzatura.

## Generalità

I bracci autocarrati sono equiparati a macchine operatrici speciali da cantiere.

La macchina non può essere adibita al trasporto di merci, fatta eccezione per gli accessori necessari al funzionamento e alla manutenzione della stessa. Non deve essere superato il carico utile, ovvero il peso totale massimo ammesso dall'autoveicolo.

Le prestazioni di lavoro di tale attrezzatura devono essere limitate alla sola operazione di distribuzione del calcestruzzo o altra massa plastica, il cui peso non superi i  $2,4 \text{ kg/dm}^3$ .

Il peso al metro lineare delle tubazioni impiegate per la condotta del calcestruzzo non deve superare i seguenti valori:

diametro interno mm. 100,8 x 3,6 = Kg. 9,33

diametro interno mm. 125 x 4 = Kg. 12,8.

Per un perfetto funzionamento, i bracci di distribuzione del calcestruzzo, devono essere fatti funzionare secondo le indicazioni contenute nel presente manuale.

Per danni dovuti all'uso inadeguato la *Waitzinger*

non si assume alcuna responsabilità, inoltre decade immediatamente la garanzia.

## Before using the machine

Carefully read this section of the manual before attempting to perform any operations with the machine !

This section contains important information that is fundamental for the correct use of the machine and will also help the operator to become acquainted with the various controls and functions, the significance of the indications, how to carry out adjustments and other important information. Particular care should be dedicated to the general safety regulations. This manual should always be kept with the machine, in order that it may be consulted on-site for eventual information and explanations.

## General information

Truck-mounted concrete distributor booms are comparable to special operating machines used on construction sites.

The vehicle is not equipped for the transport of goods, except for any accessories required for the operation and maintenance of the vehicle itself. Never exceed the maximum load carrying capacity of the vehicle.

The operating capacity of the vehicle and equipment must be exclusively limited to the distribution of concrete or other similar fluids, with weights inferior to  $2.4 \text{ Kg/dm}^3$ .

The weight per linear meter of the piping used for concrete delivery should not exceed the following values:

internal diameter mm. 100.8 x 3.6 = Kg 9.33

internal diameter mm. 125 x 4 = Kg 12.8

For optimal operation the concrete delivery booms should be made to function according to the instructions supplied in this manual.

*Waitzinger* decline all responsibility for any damages caused by incorrect use of the boom, which will also result in the immediate annulment of all warranty conditions.



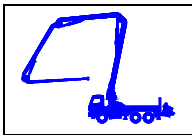

**SEZIONE B**  
**regole di sicurezza**  
**istruzioni per l'uso**

**SECTION B**  
**safety regulations**  
**instruction for use**

**Tutti i dispositivi previsti per la sicurezza** e la prevenzione degli infortuni, come tabelle di indicazione e avvertimento, protezioni, sigilli e piombature sulle valvole di sicurezza **non devono essere rimossi o modificati.**

**All safety and accident prevention devices,** such as warning and indication tables, protective appliances and seals on safety valves **must not removed or modified.**

**ATTENZIONE**

La rimozione delle piombature e la manomissione delle pressioni sulle valvole di sicurezza può essere causa di gravi incidenti. Tale operazione può essere effettuata solo da personale autorizzato e addestrato dalla *Waitzinger*.



**WARNING**

Removal of seals and tampering with the safety valve pressure may cause serious accidents. These operations should only be performed by personnel authorized and trained by the *Waitzinger* company.

**Regole generali di sicurezza**

- Nell'impianto elettrico vengono normalmente impiegate elettrovalvole a 12 o 24 volt c.c.

- L'impianto oleodinamico del braccio può raggiungere la pressione massima di 320 bar.

Controllare mediante il manometro che tale valore non venga mai superato.

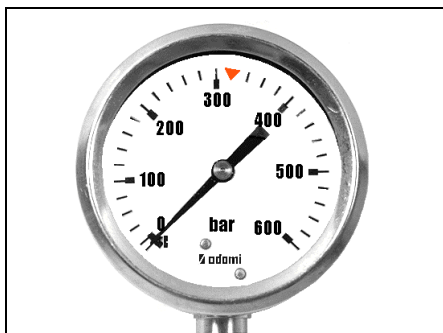

- I bracci di distribuzione del calcestruzzo comprese le tubazioni devono essere fatti controllare da un esperto, per la loro sicurezza di lavoro, almeno ogni 500 ore di lavoro.
- L'operatore della macchina deve ordinare i controlli annuali. I risultati devono essere annotati nel **Libretto d'Ispezione** fornito in dotazione con la macchina.
- Se vengono trovati difetti in parti importanti per la sicurezza di lavoro, non si potrà utilizzare la macchina fino a quando si sarà eliminato il danno. Se l'esperto non riscontra nessun difetto tecnico per la sicurezza, viene applicata una targhetta di controllo accanto a quella dei dati di identificazione del modello.

**General safety regulations**

- 12 or 24 volt d.c. solenoid valves are normally used in the electrical system.

- The boom hydraulic system can reach a maximum pressure of 320 bar.

Check that this value is not exceeded by means of the pressure gauge.

- Concrete distributor booms, including the piping, should be regularly checked by an expert at least every 500 hours of work, in order to verify the safe operation of the equipment.
- The machine operator must request that the checks take place every year and the results must be noted in the **Check book**, provided with the machine.
- If defects are detected in parts that are considered to be important for the safe operation of the machine, then the machine must not be used until these defects have been eliminated. If the expert does not encounter technical defects in relation to safety, a inspection plate will be attached to the machine next to the

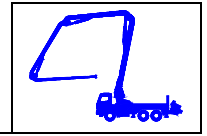

model identification data plate.

**Protezione personale  
 contro i rumori**

Non è possibile localizzare il posto di lavoro per l'operatore del braccio per calcestruzzo. Nella postazione di lavoro il valore di emissione dei rumori è inferiore a 85 db (A). A secondo del tipo di macchina o di funzionamento è tuttavia possibile che nella zona circostante la macchina detto valore superi gli 85 db (A). Come zona circostante si intende l'area compresa nel raggio di 5 metri.

**Noise protection  
 for personnel**

It is not possible to stabilize an exact working position for the concrete boom distributor operator. At the place of work the noise emission value is less than 85 db (A). However, depending on the type of machine or operation being performed, it is possible that in the vicinity of the machine this value may exceed 85 db (A). The area surrounding the machine should be considered to be a zone with a radius of approx. 5 meters.

<p><b>ATTENZIONE</b></p> <p>Nella zona circostante indossare le cuffie di protezione contro i rumori.</p>		<p><b>WARNING</b></p> <p>In the area surrounding the machine always wear protective earphones.</p>
---	--	--

Il responsabile della sicurezza è tenuto ad informare il personale che il valore di emissione dei rumori può superare gli 85 db (A), ed assicurarsi che vengano sempre indossate le apposite cuffie di protezione.

The person responsible for on-site safety must inform personnel that the noise emission value may exceed 85 db (A), and ensure that protective earphones are always worn.

<p><b>ATTENZIONE</b></p> <p>E' prescritto l'uso dell' equipaggiamento di protezione personale (elmetto, occhiali, maschera, guanti, ecc.) su tutto il campo operativo, in particolare operando con cemento o con additivi per malta a base chimica.</p>		<p><b>WARNING</b></p> <p>Personal protective equipment should always be used (safety helmets, glasses, masks, gloves, etc.) on the work site, especially when operating with cement or chemically-based additives for mortar.</p>
---	--	---

Nell'eseguire qualsiasi tipo di intervento all'impianto idraulico, indossare sempre le protezioni per il volto e per le mani. L'olio è tossico e può essere assorbito dalla pelle. Sussiste inoltre il pericolo di ustione con olio ad elevata temperatura. L'olio dell'impianto idraulico non deve essere assolutamente disperso nell'ambiente ! Raccogliere l'olio e smaltirlo come prescritto dalle normative. Lo stesso vale per altri

Always wear a mask and gloves when carrying out operations on the hydraulic system. The fluid in the system is toxic and can be absorbed through the skin. There is also a danger of burns caused by high temperature fluids. The hydraulic system fluid must never be disposed of together with normal liquid waste ! Collect the fluid and dispose of according to standard regulations. This procedure should also be adopted for all

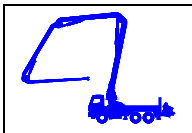

**SEZIONE B**  
*regole di sicurezza*  
*istruzioni per l'uso*

**SECTION B**  
*safety regulations*  
*instruction for use*

liquidi non biodegradabili.

other non-biodegradable liquids.

**ATTENZIONE**

L'operatore deve osservare e provvedere ai seguenti accorgimenti di sicurezza e di controllo.



**WARNING**

The operator must observe and make provision for the following safety and control procedures.

**Tubazione calcestruzzo**

- Controllare periodicamente lo stato di usura delle tubazioni di condotta del calcestruzzo mediante un apparecchio di misura dello spessore delle pareti e sostituire i pezzi usurati. Per lo spessore minimo delle pareti e la pressione massima del calcestruzzo fare riferimento al seguente diagramma:

**Concrete piping**

- Periodically control the wear condition of the concrete delivery piping, using an instrument that measures the thickness of the piping walls, replacing any worn parts. Refer to the diagram below for minimum thickness and maximum pressure values:

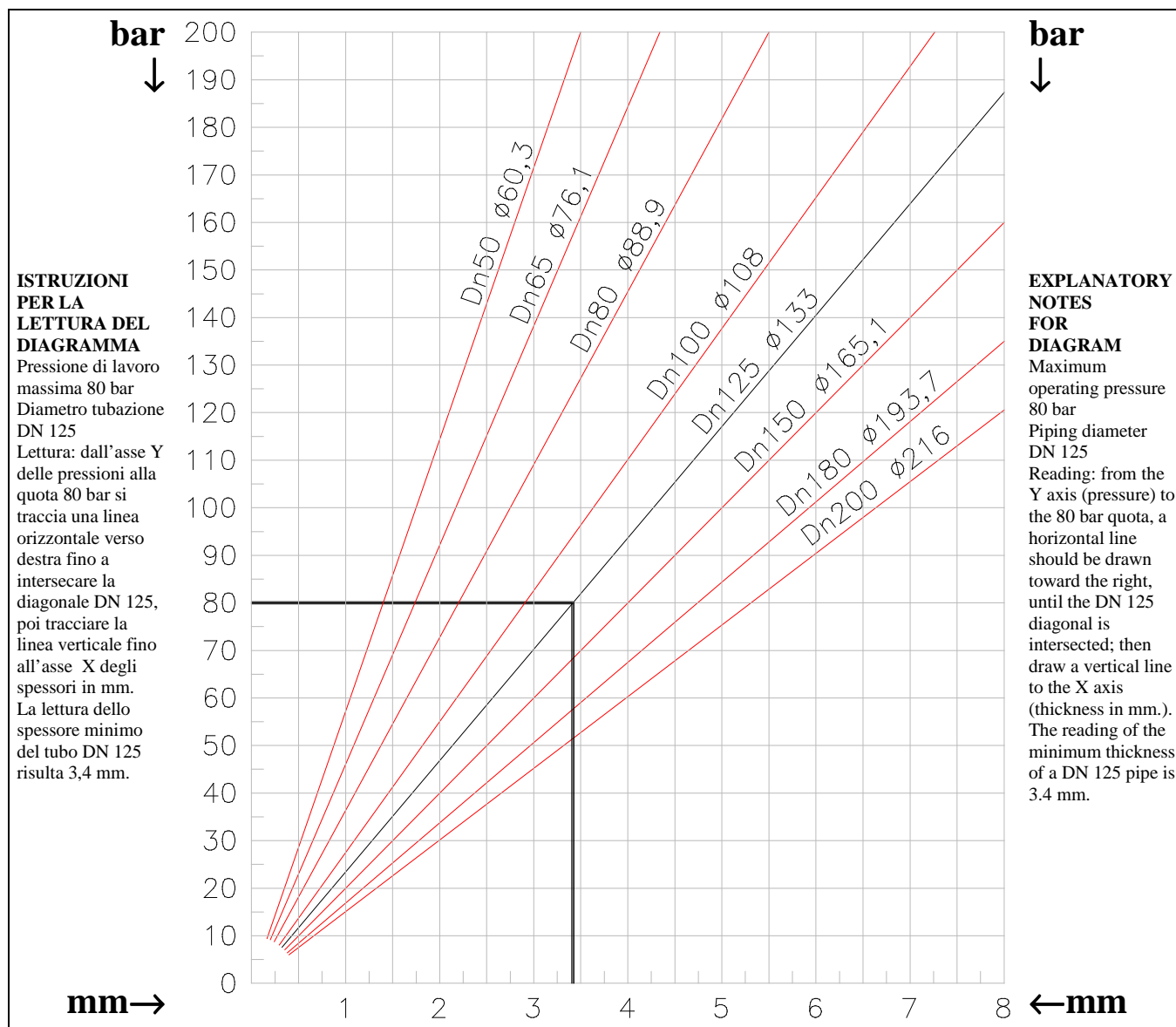

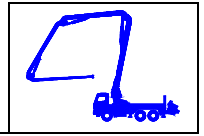

**ATTENZIONE**

Se parti consumate o difettose (tubi per calcestruzzo, tubi flessibili ad alta pressione, ecc.) non vengono sostituiti in tempo utile, il costruttore non si assume alcuna responsabilità per il prodotto.



**WARNING**

If worn or defective parts (concrete delivery piping, high pressure flexible hose, etc.) are not replaced in time, the manufacturers decline all responsibility for the product.

- Tubazioni rigide di mandata del calcestruzzo sono state posate esenti da tensioni con braccio di distribuzione chiuso e possono essere sostituiti senza difficoltà. Se dette tubazioni rigide di mandata venissero sostituite a braccio di distribuzione aperto, potrebbero verificarsi tensioni al momento del riassettaggio.
- Lo spazio fra i vari tubi e curve deve essere circa 2 mm.

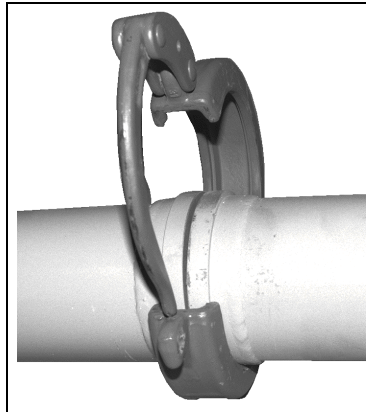

- The rigid concrete delivery piping are positioned free from tension with the distribution boom closed and can be easily replaced. If this rigid delivery piping is replaced with the distribution boom open, tension may be found to be present when assembly operations take place.
- The space between the various pipes and curves should be approx. 2 mm.

- Prima di ogni inizio lavoro, assicurarsi che il tubo terminale flessibile (1) sia solidamente fissato al braccio (2) per mezzo del collare (3) e cavo in acciaio (4), onde evitare accidentali cadute in caso di apertura della fascetta a leva (5).

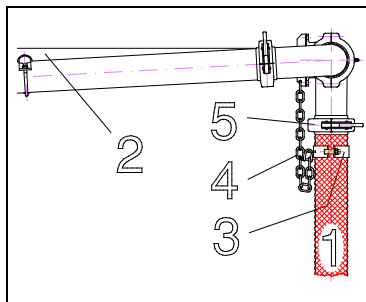

- Before starting work, check that the concrete distributor flexible end hose (1) is securely attached to the boom (2) by means of the collars (3) and steel cable (4), in order to prevent accidental dropping in the event of the lever clamp (5) opening.

- Assicurare i giunti a leva con spine di sicurezza contro l'apertura involontaria.

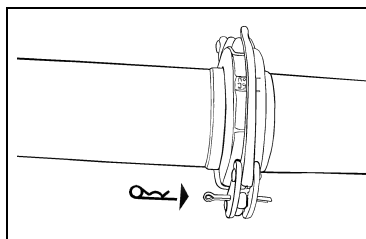

- Secure the lever joints with the safety pins, in order to prevent accidental opening.

- La tubazione per calcestruzzo nuova, installata sul braccio, sopporta la pressione massima indicata nel diagramma. Poichè lo spessore della tubazione diminuisce, per effetto dell'usura, la relativa pressione è determinabile dal diagramma.
- Ad una pressione di calcestruzzo superiore a 85 bar si deve pompare solo tramite un'uscita laterale e non attraverso il braccio di distribuzione. Con pressione del calcestruzzo tra 85 e 130 bar impiegare una tubazione speciale.

- The new concrete delivery piping, fitted on the boom, can sustain the maximum pressure indicated in the diagram. Since the thickness of the piping decreases, as a result of wear, the relative pressure can be determined on the diagram.
- At a concrete pressure of over 85 bar, pumping should only be carried out by means of a lateral outfeed point and not by means of the distribution boom. With concrete pressure between 85 and 130 bar, use special piping.

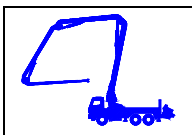

**SEZIONE B**  
*regole di sicurezza*  
*istruzioni per l'uso*

**SECTION B**  
*safety regulations*  
*instruction for use*

- Effettuare la prova di pressione per tubazioni calcestruzzo, con acqua, dopo circa 2000 m<sup>3</sup>. Pressione di prova 30% oltre la pressione d'esercizio massima presunta.
- Sostituire dopo circa 1000 m<sup>3</sup>, i giunti, le guarnizioni, le curve e i tubi per calcestruzzo collocati ad una distanza inferiore di 3 metri dal personale operatore.

- Carry out the pressure test on the concrete delivery piping, using water, after approximately 2000 m<sup>3</sup>. The test pressure should exceed the presumed maximum operating pressure by 30%.
- After approximately 1000 m<sup>3</sup>, replace the joints, the gaskets, the elbows and the concrete piping located at a distance of less than 3 meters from the operating personnel.

- Prima di aprire le condotte del calcestruzzo (anche nel caso di occlusioni) scaricare la pressione dal sistema, invertendo il senso di pompaggio.

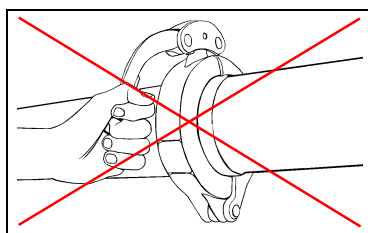

- Before opening the concrete delivery piping (also in the event of blockages) always release the system pressure by inverting the pumping direction.

- Per ottenere un'usura uniforme della tubazione per calcestruzzo ogni 3000 m<sup>3</sup> circa, eseguire le seguenti operazioni: girare i tubi di mandata di 120° in senso orario e girare le curve di 180°.

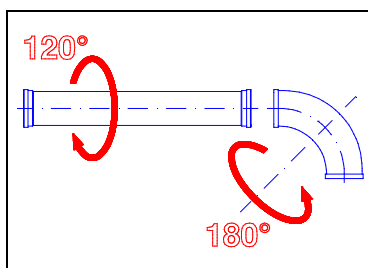

- In order to achieve uniform wear of the concrete delivery piping, carry out the following operation after every 3000 m<sup>3</sup>: rotate the delivery pipes through 120° in a clockwise direction and rotate the elbow curves through 180°.

- Durante tale operazione è necessario controllare lo spessore minimo delle pareti e consultare il diagramma per valutare la pressione massima sopportabile dalla tubazione.

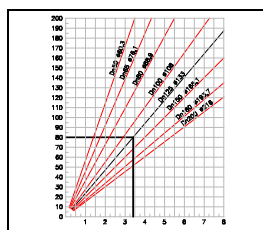

- Whilst carrying out this operation the minimum thickness of the piping walls should also be checked, consulting the aforementioned diagram in order to evaluate the maximum pressure that the piping may sustain.

- Le tubazioni originali per calcestruzzo sono provviste di una targhetta che identifica:
- Pressione di esercizio
- Diametro nominale interno
- Codice del pezzo

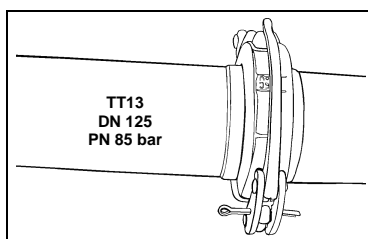

- Original concrete delivery piping is provided with an identification plate that notes:
- Operating pressure
- Nominal internal diameter
- Code of the piece

- Si consiglia di utilizzare soltanto tubazioni per calcestruzzo originali.

- It is strongly advised to only use original concrete delivery piping.

**ATTENZIONE**

E' severamente vietato usare tubazioni per calcestruzzo aventi diametri e spessori maggiori di quelli originali indicati nel presente manuale.



**WARNING**

The use of concrete delivery piping with diameters and thicknesses inferior to the original values indicated in this manual is strictly prohibited.

**SEZIONE B**  
*regole di sicurezza*  
*istruzioni per l'uso*

**SECTION B**  
*safety regulations*  
*instruction for use*

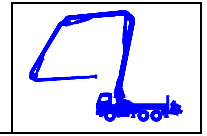

- Non piegare mai il tubo terminale flessibile durante il pompaggio. Il tubo terminale intasato o immerso nel calcestruzzo rende maggiore il pericolo di infortuni.

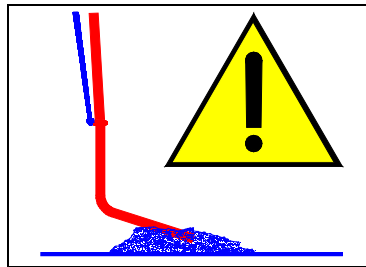

- Never bend the concrete distributor flexible end hose during pumping operations. If the end hose is obstructed or immersed in concrete the risk of accidents is notably increased.

**ATTENZIONE**

Quando il terminale resta immerso nel calcestruzzo, non deve mai essere estratto azionando il braccio, in quanto tale azione determina pericolose tensioni sulla struttura.



**WARNING**

When the end hose remains immersed in concrete it should never be extracted by operating the boom, as this action places the structure under a dangerous tension level.

- Quando si inizia il pompaggio, anche dopo l'eliminazione di intasamenti, il terminale flessibile deve pendere liberamente e nessuno deve sostare nell'area che ha per raggio la sua lunghezza.

- When pumping operations begin, even after the elimination of the obstruction, the end hose must be allowed to hang free, and personnel should be prevented from entering the area of its range of action.

**ATTENZIONE**

E' vietato sostare nel raggio d'azione del terminale flessibile.

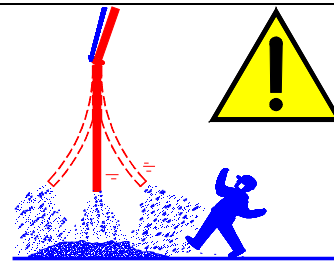

**WARNING**

Personnel are prohibited from entering the end hose range of action.

- E' pericoloso condurre manualmente il terminale flessibile soprattutto nelle fasi iniziali del pompaggio. E' consigliabile condurre il tubo terminale con un apposito attrezzo.

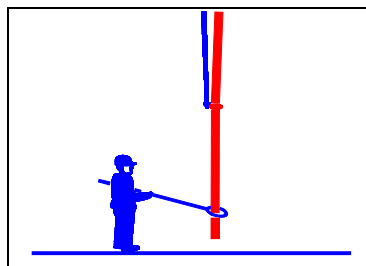

- The flexible end hose should not be guided manually, above all during the initial phase of the pumping operation. In order to avoid danger it is advised to use a special tool to guide the end hose.

- L'addetto alla distribuzione del calcestruzzo non deve mai operare sotto la struttura del braccio.

- The operator responsible for the distribution of the concrete should not remain in a position below the boom structure.

**ATTENZIONE**

**PERICOLO DI CADUTA CORPI**  
 E' vietata la sosta di personale non autorizzato nel campo operativo della macchina.

**In caso di pericolo interrompere il lavoro.**

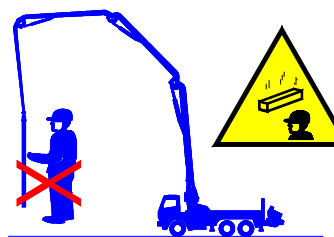

**WARNING**

**DANGER OF FALLING OBJECTS**  
 Only authorized personnel are allowed to remain within the machine operative field.

**In the event of danger, stop work.**

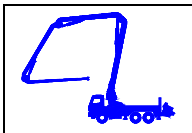

**SEZIONE B**  
*regole di sicurezza*  
*istruzioni per l'uso*

**SECTION B**  
*safety regulations*  
*instruction for use*

- La pulizia della tubazione di mandata del calcestruzzo deve essere effettuata con acqua.

- Water should be used to clean the concrete delivery piping.

**RISCHIO DI ESPLOSIONE**

La pulizia della tubazione con aria compressa comporta dei rischi di esplosione.



**RISK OF EXPLOSION**

Cleaning the piping with compressed air may cause a risk of explosion.

- A causa della pericolosità il costruttore declina ogni responsabilità.

- Because of the potential danger of this operation, the manufacturers decline all responsibility.

**Campo operativo**

- Durante l'impiego della macchina l'operatore è responsabile per tutto il campo operativo, che deve essere delimitato in modo ben chiaro o reso inaccessibile a persone non autorizzate.

**Field of operation**

- Whilst the machine is in use the operator is responsible for the entire range of operation, which should be clearly delimited or made inaccessible to unauthorized personnel.

**ATTENZIONE**

Sbarrare adeguatamente il campo operativo al traffico.

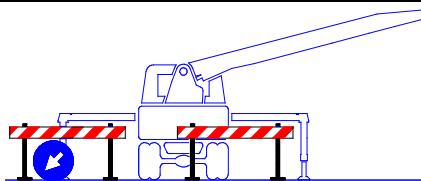

**WARNING**

Erect traffic barriers at access points to the operating area.

- L'operatore deve avere sempre completa visione dell'intero campo operativo e delle eventuali zone di pericolo. Nel caso in cui ciò non fosse possibile dovrà essere incaricato un assistente per la sorveglianza.
- Nell'abbandonare il posto di lavoro l'operatore deve sempre assicurare la macchina contro un eventuale uso abusivo o spostamenti accidentali.
- Quando si azionano gli stabilizzatori, assicurarsi che non vi siano operatori in sosta nel loro raggio d'azione.

- The operator must always have complete overall vision of the field of operation and the potential danger zones. If this is not possible the operator must be provided with an assistant for surveillance purposes.
- Before leaving the work site the operator must make sure that the machine is made safe and cannot be used by unauthorized personnel or accidentally moved.
- When operating the stabilizers, make sure that personnel are kept clear of their range of action.

**ATTENZIONE**

Pericolo di schiacciamento di parti del corpo.

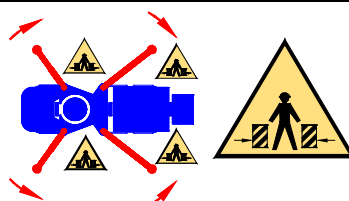
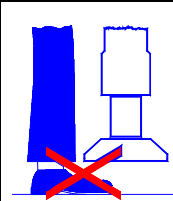

**WARNING**

Danger of crushing.

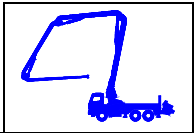

**Segnalazioni manuali**

**Hand signals**

**Azioni del braccio**

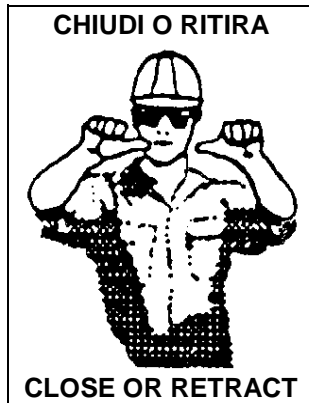
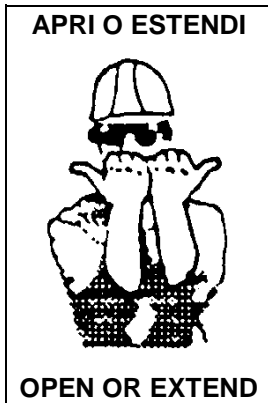

**Manoeuvre of concrete boom**

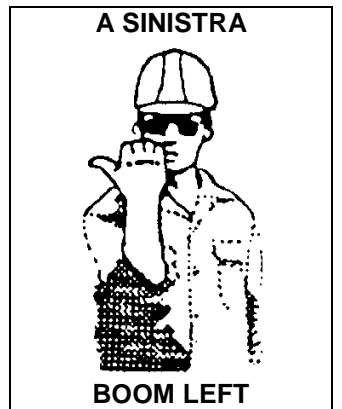
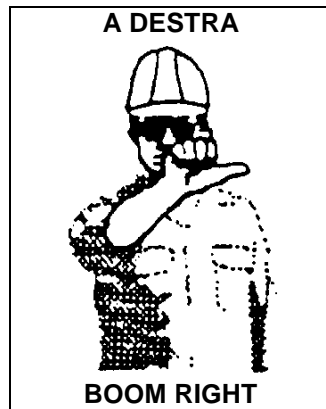
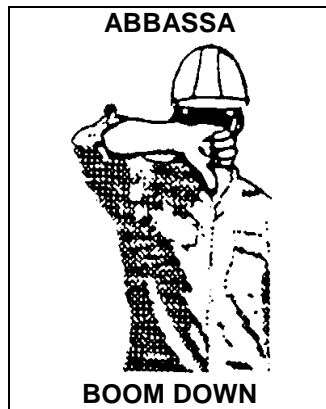
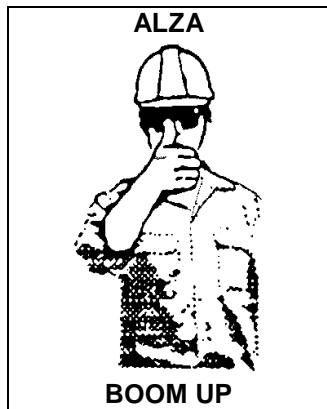

**Azioni della pompa per calcestruzzo**

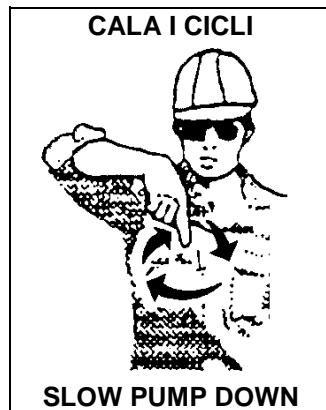
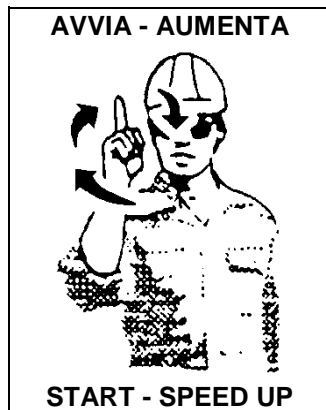

**Manoeuvre of concrete pump**

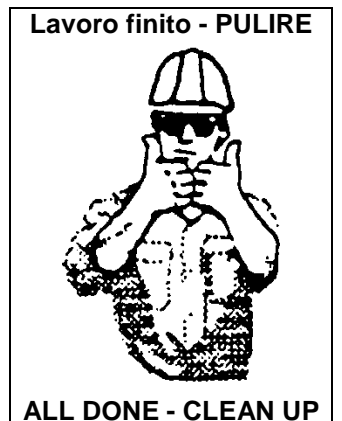
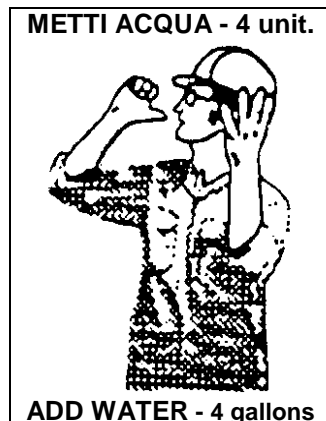
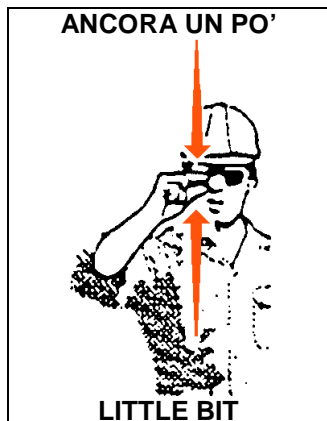



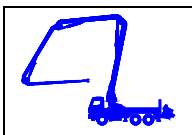

**SEZIONE B**  
*regole di sicurezza*  
*istruzioni per l'uso*

**SECTION B**  
*safety regulations*  
*instruction for use*

**Influenza del vento**

Il forte vento può sovraccaricare il braccio di distribuzione del calcestruzzo.

Durante il servizio, tenere continuamente in considerazione la velocità del vento.

**Effect of the wind**

Strong winds may overload the concrete distributor on the boom.

During operation keep a constant check on the wind speed.

**ATTENZIONE**

La velocità massima ammissibile del vento è comparabile al **grado 7** della scala **BEAUFORT**. Quando viene superata, interrompere il lavoro e ripiegare il braccio nella posizione di marcia dell'autoveicolo.



**WARNING**

The maximum permissible wind speed is comparable to **strength 7** on the **Beaufort** scale. When this level is exceeded, interrupt work and fold away the boom into the traveling position on the vehicle.

Per la valutazione della forza del vento e della velocità si fa riferimento alla seguente tabella:

In order to evaluate the strength of the wind, refer to the following table:

FORZA DEL VENTO		Velocità del VENTO		EFFETTO DEL VENTO IN ZONA INTERNA
grado BEAUFORT	DENOMIN.	m/s da a	Km/h da a	
<b>0</b>	calma	0 0,2	0 1	Calma, il fumo sale diritto in alto.
<b>1</b>	leggero movimento d'aria	0,3 1,4	1 5	Direzione del vento indicata solamente dal movimento del fumo, ma non da ventarola.
<b>2</b>	venticello leggero	1,6 3	6 11	Il vento si sente in faccia, le foglie stormiscono, la ventarola si muove.
<b>3</b>	brezza debole	3,4 5,3	12 19	Foglie e rami leggeri si muovono, il vento stende i guidoncini.
<b>4</b>	brezza moderata	5,5 7,8	20 28	Sollewa la polvere e carta libera, muove i rami e aste più fini.
<b>5</b>	brezza fresca	8 10,6	29 38	Piccoli labifogli cominciano ad ondeggiare, sul lago si muovono teste di spuma.
<b>6</b>	vento forte	10,8 13,7	39 49	Aste forti in movimento, sibili nelle linee telegrafiche, difficile usare ombrelli.
<b>7</b>	vento teso	13,9 17	50 61	Tutti gli alberi si muovono, si è ostacolati sensibilmente ad andare controvento.
<b>8</b>	vento di tempesta	17,2 20,6	62 74	Spezza i rami degli alberi, rende notevolmente difficoltoso camminare all'aperto.
<b>9</b>	tempesta	20,8 24,5	75 88	Piccoli danni alle case, procura cadute di tegole e coperchi di camini.
<b>10</b>	violenta tempesta	24,7 28,3	89 102	Alberi sradicati, danni notevoli alle case.

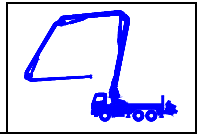

WIND FORCE		WIND SPEED		INLAND WIND EFFECT
BEAUFORT scale	Classification	m/s from to	Km/h from to	
<b>0</b>	calm	0 0,2	0 1	Calm, smoke rises vertically.
<b>1</b>	Slight movement of the air	0,3 1,4	1 5	The wind direction is only indicated by the movement of the smoke, but not by the weathercock.
<b>2</b>	Light wind	1,6 3	6 11	The wind can be felt on the face, leaves rustle, the weathercock moves.
<b>3</b>	Weak breeze	3,4 5,3	12 19	Leaves and twigs move, the wind unfurls small pennants.
<b>4</b>	Moderate breeze	5,5 7,8	20 28	Dust and wastepaper are lifted, branches and slender flagpoles are moved.
<b>5</b>	Fresh breeze	8 10,6	29 38	Small leaves begin to undulate, foam forms on the waves on lakes.
<b>6</b>	Strong wind	10,8 13,7	39 49	Sturdy flagpoles move, telephone wires begin to whistle, umbrellas are difficult to handle.
<b>7</b>	Very strong wind	13,9 17	50 61	All trees move, it is somewhat difficult to move against the wind current.
<b>8</b>	Gale force wind	17,2 20,6	62 74	Branches are torn from trees, it is very difficult to walk outside.
<b>9</b>	Gale	20,8 24,5	75 88	Limited damage to buildings, tiles and chimney tops are blown off.
<b>10</b>	Violent gale	24,7 28,3	89 102	Trees are torn up by the roots, significant damage to buildings.

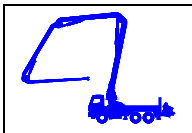

## Installazione della macchina

### Premessa:

L'operatore deve essere istruito e sottoscrivere di aver preso visione delle norme contenute nel presente manuale d'uso. L'operatore è inoltre obbligato ad osservare le norme di prevenzione contro gli infortuni sul lavoro e a rispettare le istruzioni del presente manuale relative all'utilizzo e alla manutenzione del braccio per calcestruzzo. L'inosservanza di tali norme, o l'incompleta manutenzione degli apparati della macchina, implica la decadenza della garanzia del costruttore.

Per l'uso e la manutenzione di macchine con pompe e bracci per calcestruzzo deve essere impiegato solo personale che abbia i seguenti requisiti:

- compiuto il 18° anno di età.
- attestata idoneità psicofisica.
- sia stato istruito sull'uso e la manutenzione del braccio e dimostrato idonea preparazione di fronte al responsabile della sicurezza sul lavoro.
- abbia dimostrato la propria competenza e professionalità nello svolgimento degli incarichi ad esso assegnati.

### **Controlli da eseguire prima dell'avviamento:**

- Prima di iniziare il pompaggio controllare il sicuro fissaggio della tubazione di mandata del calcestruzzo, delle spine di sicurezza nei giunti a leva e del terminale flessibile.
- Verificare che non vi siano perdite dai circuiti oleodinamici. Serrare all'occorrenza i raccordi sui tubi flessibili, sulle valvole e su tutti i particolari relativi all'impianto.

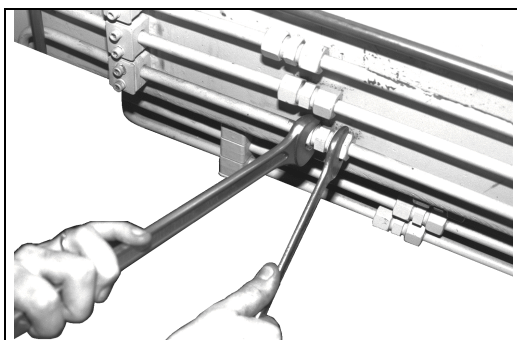

- Check that there are no leaks in the hydraulic circuit. Where necessary, tighten the unions on the flexible hose, on the valves and on all other relative parts of the system.

## Machine installation

### Preface:

The operator should be trained and must undersign the fact that the norms indicated in this instruction manual have been studied. Accident prevention at work safety norms must also be observed, as well as the instructions concerning the use and maintenance of the concrete distributor boom.

Non-compliance with these norms, or incomplete machine equipment maintenance operations, will result in the annulment of the manufacturer's warranty.

The use and maintenance of machines with pumps and concrete distributor booms should be exclusively reserved to personnel with the following requisites:

- over 18 years of age;
- certified psycho-physical eligibility;
- trained in the use and maintenance of the boom, with a demonstration of aptitude before the person responsible for safety at work.
- proven competence and professionalism in the accomplishment of the assigned tasks.

### **Checks to be carried out before starting the machine:**

- Before starting pumping operations, check the secure attachment of the concrete delivery piping, the safety pins on the lever joints and the flexible end hose.

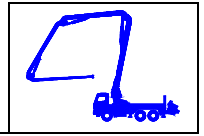

## Apertura stabilizzatori

- Prima di stabilizzare la macchina, piazzare le calzaioie, sbloccare il freno e muovere il veicolo verso le calzaioie. Successivamente riassicurare il freno di stazionamento del veicolo.

## Stabilizing the machine

- Before stabilizing the machine, position the chocks, release the brake and move the vehicle towards the chocks. Then re-apply the vehicle parking brake.

### ATTENZIONE

Su terreni in discesa l'autoveicolo potrebbe mettersi in movimento anche se stabilizzato.



### WARNING

On downward sloping terrain the vehicle may start to move, even if the stabilizers are in operation.

- La macchina va installata in modo che sia garantita una sicura stabilità per l'intero raggio d'azione del braccio.
- La responsabilità della sicurezza contro il ribaltamento è a carico dell'operatore del braccio, che ha l'obbligo di controllare la consistenza del sottosuolo e di rifiutare di operare se esistono dubbi sulla stabilità.
- La portata del sottosuolo è espressa in  $\text{KN/m}^2$ .
- I piatti di appoggio degli stabilizzatori vanno estesi mediante le piastre (A), in modo da evitare che sprofondino nel terreno.

- The machine should be positioned so that safe stability is guaranteed for the entire operating range of the boom.
- The safety of the vehicle and the prevention of overturning are the responsibility of the boom operator, who must check the consistency of the subsurface and who must refuse to operate the equipment if doubts exist in relation to the stability of the machine.
- The load bearing capacity of the subsurface is expressed in  $\text{KN/m}^2$ .
- The stabilizer support feet are fitted with plates (A), in order to prevent the stabilizer sinking into the ground.

I piatti di appoggio standard (martinetti stabilizzatori), secondo le dimensioni sono idonei a pressioni superficiali di  $150/300 \text{ KN/m}^2$ .

Nel caso sia necessaria una superficie d'appoggio maggiore, l'operatore dovrà utilizzare dei travetti (B) delle dimensioni minime di  $15 \times 15 \text{ cm}$  e delle lunghezze (C) indicate nella tabella di riferimento. Dalla tabella risulta quando è sufficiente la piastrina (A) o quando occorre estenderle con i travetti (B) che verranno sempre utilizzati a gruppi di quattro sistemati in modo da formare una superficie compatta sotto il punto di appoggio.

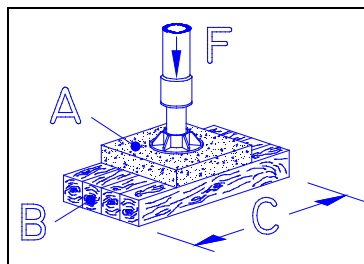

The standard support feet (stabilizer jacks) can sustain superficial pressures of  $150/300 \text{ KN/m}^2$ , depending on the dimensions. If a larger support surface is required, the operator should use joists (B) with minimum dimensions of  $15 \times 15 \text{ cm}$  and of the length (C) shown in the reference table.

The table also shows when the plate (A) is sufficient, or when it will be necessary to use joists (B), which should always be used in groups of four and positioned so that they form a compact surface under the point of support.

### Superficie di appoggio

La prima tabella riporta alcuni valori indicativi con i quali è possibile stabilire la resistenza della superficie di appoggio presa in esame.

### Support surface

The first table shows a few indicative values by which the resistance of the support surface in question can be determined.

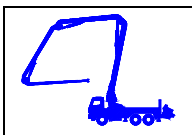

**SEZIONE B**  
*regole di sicurezza*  
*istruzioni per l'uso*

**SECTION B**  
*safety regulations*  
*instruction for use*

Dalla seconda tabella, in funzione ai valori di resistenza del terreno e di carico di stabilizzazione della macchina, è possibile determinare le lunghezze minime dei travetti in legno (**B**), da sistemare sotto la piastrina (**A**), o se il terreno risulta adatto o inaffidabile alla stabilizzazione.

The second table, according to the resistance values of the ground and the stabilizing load of the machine, allows the minimum length of the wooden joists (**B**), that are to be positioned under the plate (**A**), to be determined. It also indicates whether the ground surface is unsuitable or unreliable for the stabilizing operation.

PRESSIONE AMMESSA PER SUPERFICIE ( $P_s$ )	
tipo di superficie	KN/m <sup>2</sup>
Terreno naturale	150
Asfalto con spessore minimo 20 cm.	200
Pietrisco costipato	250
Terreno argilloso e limaccioso	300
Terreno variamente granulato	350
Ghiaia	400/500
Ghiaia ben compatta	750
Roccia friabile, disgregata	1000

PERMITTED SURFACE PRESSURES ( $P_s$ )	
type of surface	KN/m <sup>2</sup>
Normal ground	150
Asphalt with 20 cm. min. thickness	200
Tamped crushed stone	250
Clayish and slimy ground	300
Different degrees of granulated ground	350
Gravel	400/500
Suitably compressed gravel	750
Crumbly weathered rock	1000

I carichi verticali degli stabilizzatori (**F**), espressi in KN, sono riportati nelle targhette poste su ciascun martinetto.

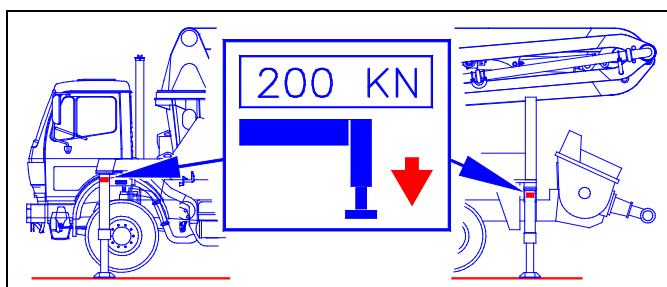

Vertical stabilizer loads (**F**), expressed in KN, are noted on the plate fitted on each of the jacks.

Verificare i carichi massimi sia sugli stabilizzatori anteriori che su quelli posteriori, poichè i valori possono risultare diversi.

Check the maximum loads on both the front and rear stabilizers, as the values may differ.

	PRESSIONE AMMESSA PER SUPERFICIE ( $P_s$ ) dalla tabella sopra, espressi in KN/m <sup>2</sup>														
	CARICHI STABILIZZATORI ( <b>F</b> ) dalla targhetta sul martinetto, espressi in KN														
	50	75	100	125	150	175	200	225	250	275	300	325	350	375	400
150		84	112	138	166	194									
200			84	104	126	147	166	187							
250				84	89	117	132	150	166	184					
300	superficie				84	96	112	126	138	154	166	180			
350	adatta alla					84	96	106	120	132	144	153	166	180	190
400	stabilizzazione con la sola						84	94	104	115	126	135	147	156	166
500	piastrella di appoggio 60x60 cm. ( <b>A</b> )							74	84	91	98	109	117	126	132
750	senza l'ausilio dei travetti in legno ( <b>B</b> )											73	77	84	89
1000															↑

**LUNGHEZZE MINIME (**C**) DEI TRAVETTI (**B**) espresse in cm.**

**SEZIONE B**  
**regole di sicurezza**  
**istruzioni per l'uso**

**SECTION B**  
**safety regulations**  
**instruction for use**

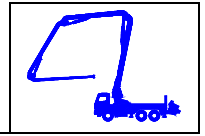

	PERMITTED SURFACE PRESSURES ( $P_s$ ) from the table above, expressed in $\text{KN/m}^2$														
	STABILIZER LOADS ( $F$ ) from the jack plates, expressed in $\text{KN}$														
	50	75	100	125	150	175	200	225	250	275	300	325	350	375	400
150		84	112	138	166	194									
200			84	104	126	147	166	187							
250				84	89	117	132	150	166	184					
300	surfaces				84	96	112	126	138	154	166	180			
350	suitable for					84	96	106	120	132	144	153	166	180	190
400	stabilizing operations using						84	94	104	115	126	135	147	156	166
500	only the 60x60 cm. support plate (A)							74	84	91	98	109	117	126	132
750	without using wooden joists (B)											73	77	84	89
1000															↑

**MINIMUM LENGTH (C) OF THE JOISTS (B) expressed in cm.**

<p><b>ATTENZIONE</b></p> <p>L'installazione della macchina su terreno di riporto può provocare instabilità a causa del cedimento del piano di appoggio.</p>		<p><b>WARNING</b></p> <p>The positioning of the machine on embankments may cause instability as a result of the support surface subsidence.</p>
---	--	---

Rispettare le distanze di sicurezza da pozzi, scarpate, scavi di fondazione, linee elettriche aeree, ecc.  
 Come valore di guida seguire la seguente regola: la distanza dall'appoggio alla fossa deve essere uguale o maggiore della profondità della fossa stessa.

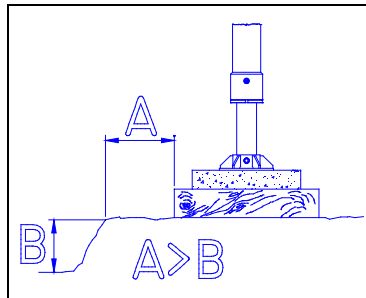

Always remain at a safe distance from wells, slopes, foundation excavations, overhead electrical cables, etc. Follow this simple guideline: the distance between the support and the trench should always be equal to or greater than the depth of the trench itself.

Il sottosuolo deve essere piano: se le piastrelle d'appoggio vengono posate su delle asperità o su delle cavità, si rompono. Su terreni in pendenza sistemare le piastrelle in piano, come illustrato a lato.

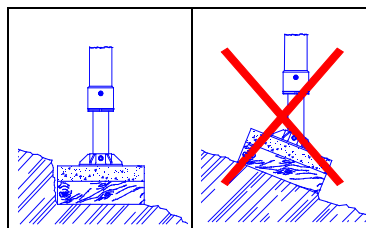

The subsurface should be level: if the support plates are positioned on upward projecting bumps or hollows, they will break. On sloping ground, position the plates on a level, as shown in the drawing.

<p><b>ATTENZIONE</b></p> <p>Un posizionamento errato degli stabilizzatori può provocare instabilità o ribaltamento della macchina.</p>		<p><b>WARNING</b></p> <p>Incorrect positioning of the stabilizers could cause machine instability or overturning.</p>
--	--	---

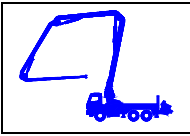

**Avviamento**

- Assicurarsi che le leve dei comandi del braccio e stabilizzatori siano nella posizione di chiusura (posizione centrale).
- Inserire il connettore del comando a distanza nell'apposita presa sulla macchina.
- Attivare il dispositivo di arresto premendo il tasto EMERGENCY-STOP posto sul telecomando per bloccare le funzioni di movimento del braccio.
- Avviare il motore ed innestare la presa di forza che aziona la pompa oleodinamica.

**Azionamento degli stabilizzatori**

I comandi per gli stabilizzatori sono posti su entrambi i lati della macchina e sono indipendenti tra loro.

Con i comandi di destra è possibile azionare solo gli stabilizzatori di destra e da sinistra i relativi.

Inoltre l'azionamento degli stabilizzatori implica l'azione simultanea di due comandi (oleodinamico con consenso elettrico).

Tale procedura è atta a garantire la sicurezza da manovre errate o involontarie da parte del personale operatore alla macchina.

Per mettere in funzione i deviatori di flusso (1,2,3) azionare dapprima la levetta (A) dell'interruttore elettrico posto accanto alla segnaletica, muovendo la stessa nella direzione in cui si intende operare, indicata dalle frecce rosse e nere. Quindi, con l'altra mano, agire sul deviatore corrispondente al movimento che si intende effettuare.

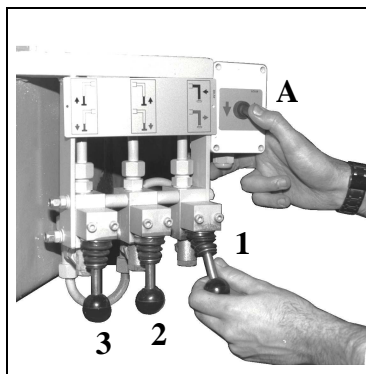

In order to operate the flow converters (1,2,3) first activate the electric switch lever (A), fitted next to the sign, by moving it in the direction in which you wish to operate, indicated by the red and black arrows. Then, with the other hand, activate the converter that corresponds with the movement that is required to be carried out.

Entrambi i comandi sono provvisti di dispositivo *uomo-morto*.

Both controls are fitted with a *dead man's handle* device.

In prossimità di ciascun comando sono poste le targhette che descrivono la funzione del comando stesso attraverso una serie di simboli.

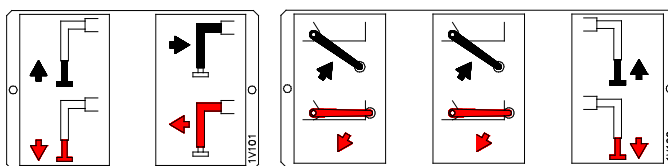

Plates have been positioned near each of the controls describing the function of the control by means of symbols.

**SEZIONE B**  
*regole di sicurezza*  
*istruzioni per l'uso*

**SECTION B**  
*safety regulations*  
*instruction for use*

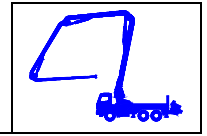

**1.** Azionare le leve corrispondenti alle funzioni di apertura dello stabilizzatore, sia anteriore che posteriore.

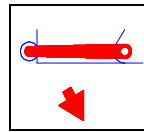

**1.** Operate the lever that corresponds to the opening function of both the front and rear stabilizer elements.

**2.** Azionare la leva corrispondente alla funzione di sfilamento dell'elemento telescopico dello stabilizzatore anteriore.

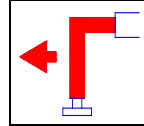

**2.** Operate the lever that corresponds to the extending function of the front stabilizer telescopic element.

**3.** Azionare le leve corrispondenti alle funzioni di abbassamento dello stabilizzatore, sia anteriore che posteriore.

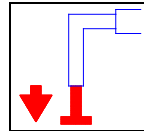

**3.** Operate the lever that corresponds to the lowering function of both the front and rear stabilizers.

**4.** Eseguire le operazioni su entrambi i lati della macchina.

**4.** Carry out these operations on both sides of the machine.

Dopo l'apertura degli stabilizzatori assicurarsi di aver estratto completamente gli elementi telescopici fino al raggiungimento delle dimensioni di stabilizzazione indicate nell'illustrazione.

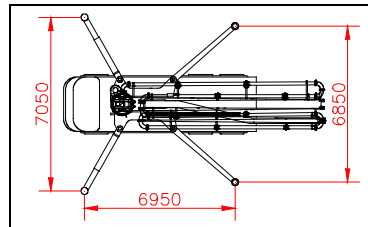

After having opened the stabilizers, make sure that the telescopic elements are fully extended, until they have reached the stabilizer dimensions indicated in the illustration.

Le dimensioni della larghezza di stabilizzazione sono riportate anche sulla targhetta che descrive il campo di lavoro, posta sulla macchina.

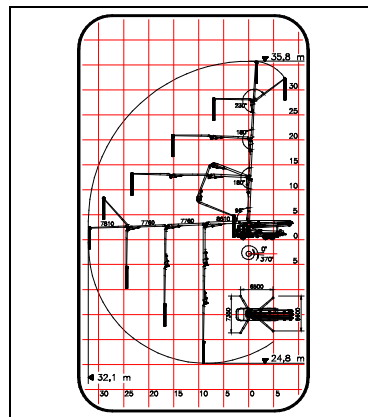

The width dimensions of the stabilizing operation are also noted on the plate describing the operative field of the machine.

Lo stabilizzatore è completamente estratto quando le frecce sono allineate.

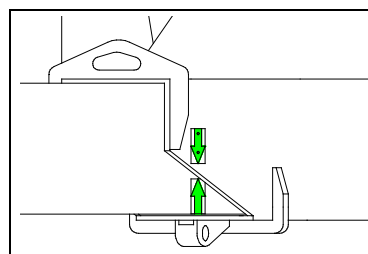

The stabilizer is fully extended when the arrows are aligned.

**ATTENZIONE**

Un'apertura parziale degli elementi telescopici degli stabilizzatori può provocare il ribaltamento della macchina.



**WARNING**

Only partial extension of the stabilizer telescopic elements may cause the machine to overturn.



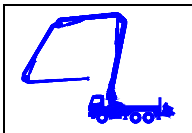

**SEZIONE B**  
*regole di sicurezza*  
*istruzioni per l'uso*

**SECTION B**  
*safety regulations*  
*instruction for use*

**L'autoveicolo, durante l'estensione del braccio, deve agire da contrappeso.**

**The vehicle acts as a counterweight whilst the boom is extended.**

Posizionare l'autoveicolo nella corretta linea orizzontale sollevandolo fino a quando le ruote si sollevano dal suolo.

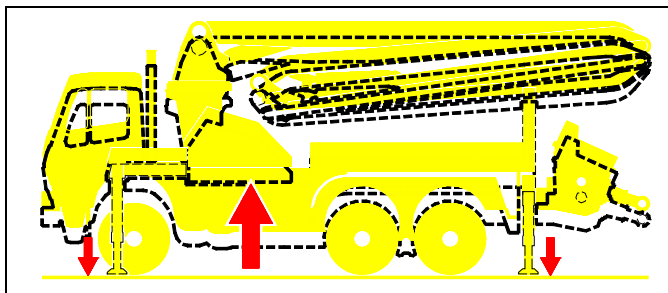

Position the vehicle correctly on the horizontal line, raising it until the wheels are above the ground.

**L'inclinazione massima ammessa è di 3°.**

Inclinazioni maggiori sovraccaricano il meccanismo di rotazione del braccio di distribuzione e compromettono la sicurezza e la stabilità della macchina.

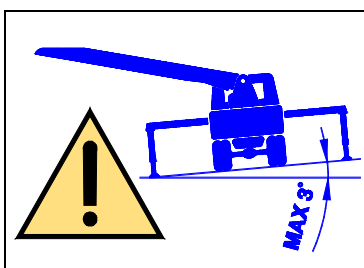

**The maximum admissible inclination is 3°.**

Greater degrees of inclination will overload the rotation mechanism of the distributor boom, jeopardizing the stability and safety of the machine.

Installare la macchina osservando la livella. Correggere la posizione agendo sui comandi dei singoli stabilizzatori.

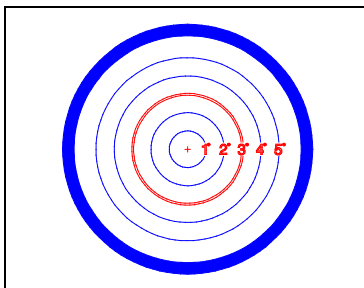

Carefully observe the even level when positioning the machine. Correct the position by operating on each of the individual stabilizers.

Durante il pompaggio del calcestruzzo tenere continuamente sotto controllo gli stabilizzatori e all'occorrenza correggere la posizione.

Continually check the condition of the stabilizers during concrete pumping operations and, if necessary, correct their position.

**ATTENZIONE**

Prima di azionare il braccio devono essere regolarmente sistemati tutti gli stabilizzatori.



**WARNING**

Before operating the boom, all of the stabilizers must be correctly positioned.

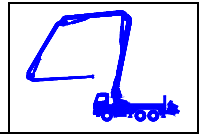

## Azionamento del braccio

Il braccio viene azionato a distanza, mediante il telecomando. Il comando del braccio può avvenire anche attraverso il radiocomando che, considerato come accessorio, viene fornito a richiesta. Tale accessorio viene appositamente studiato e realizzato dalla *Waitzinger*, per le proprie macchine, ed è severamente vietato utilizzare radiocomandi non forniti e approvati dal costruttore stesso. Specifiche e istruzioni per l'uso del radiocomando, quando installato, sono riportate nella sezione *H accessori* del presente manuale.

### Controlli da eseguire prima dell'azionamento del braccio:



- **controllo oleodinamico**

Dopo aver effettuato l'avviamento nelle modalità già descritte, dopo avere innestato la presa di forza e dopo aver aumentato i giri al motore, quando si intende procedere all'azionamento del braccio è consigliabile effettuare la verifica della pressione oleodinamica. Controllare la massima pressione oleodinamica dal manometro applicato sulla plancia comandi a bordo macchina. La pressione non deve essere superiore a quella indicata sulla targhetta dei dati di identificazione posta sulla macchina.

- **comando telecomando**

Nel caso si proceda all'azionamento del braccio dopo una pausa di lavoro, occorre ripristinare il collegamento fra telecomando e macchina allacciando i connettori. Assicurarsi comunque che il comando EMERGENCY-STOP sia abilitato alla movimentazione del braccio.

## Operation of the boom

The boom is remote control operated. The boom may also be controlled by means of a radio control, considered as an accessory, that can be supplied on request. This accessory has been specially designed and produced by the *Waitzinger* company for its vehicles. The use of radio controls that are not supplied or approved by the manufacturer is strictly prohibited. The specifications and instructions for use of the radio controls, when fitted, are described in section *H -accessories* in this manual.

### Checks to be carried out before operating the boom:



- **hydraulic control**

After having started the machine by means of the previously described procedure, with the power takeoff engaged and the engine revs increased, before proceeding with the operation of the boom it is advised that the hydraulic pressure is checked. Check the maximum hydraulic pressure on the pressure gauge positioned on the control panel on board the machine. The pressure should not exceed the value indicated on the data identification plate on the machine.

- **remote control**

If boom operation is recommenced after a work break, the handset device must be reconnected to the machine, by means of the connector. Make sure that the boom movement EMERGENCY-STOP control is enabled.

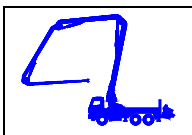

**SEZIONE B**  
*regole di sicurezza*  
*istruzioni per l'uso*

**SECTION B**  
*safety regulations*  
*instruction for use*

• **comando di emergenza**

Quando il raggiungimento della condizione al limite della sicurezza può comportare condizioni di pericolo, per arrestare le funzioni del braccio si deve utilizzare il pulsante a fungo **EMERGENCY-STOP** dal telecomando. Lo stesso risultato si ottiene agendo direttamente sul pulsante dalla valvola di emergency stop collocata sul distributore.

• **emergency control**

When safety condition limits have been reached and danger conditions are imminent, the boom operation can be stopped by means of the **EMERGENCY-STOP** push button on the handset control panel. The same result can be obtained by operating directly on the emergency stop valve push button fitted on the distributor.

**ATTENZIONE**

Il braccio non deve mai essere utilizzato come paranco o gru per il sollevamento dei pesi.

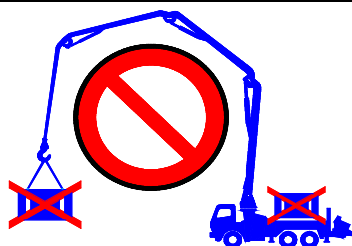

**WARNING**

The boom should never be used as a hoist or crane for lifting or handling loads.

- Mantenere le seguenti distanze di sicurezza dalle linee elettriche aeree:

Fino a 380 kV.....5 m  
Quando non è nota la tensione nominale  
o in caso di forte umidità.....10 m  
Tensione nominale in volt (V)      Distanze di sicurezza in metri (m)

- Maintain the following safety distances from overhead electrical cables:

Up to 380 kV.....5 m  
When the nominal tension is not known  
or if there is a strong dampness .....10 m  
Nominal tension in volts (V)      Safety distance in meters (m)

**ATTENZIONE**

AI CAVI AD ALTA TENSIONE

**PERICOLO DI MORTE**

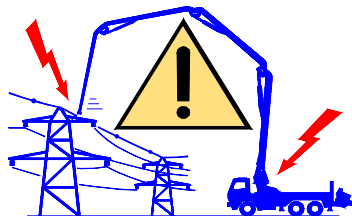

**WARNING**

BEWARE OF HIGH VOLTAGE  
POWER LINES

**DEATH HAZARD**

Per l'azionamento del braccio eseguire con precisione e cronologia le operazioni di seguito riportate.

Tutti le funzioni di movimento del braccio sono centralizzate sul telecomando. Ciascuna funzione è contraddistinta da un simbolo grafico che identifica il relativo movimento esercitato.

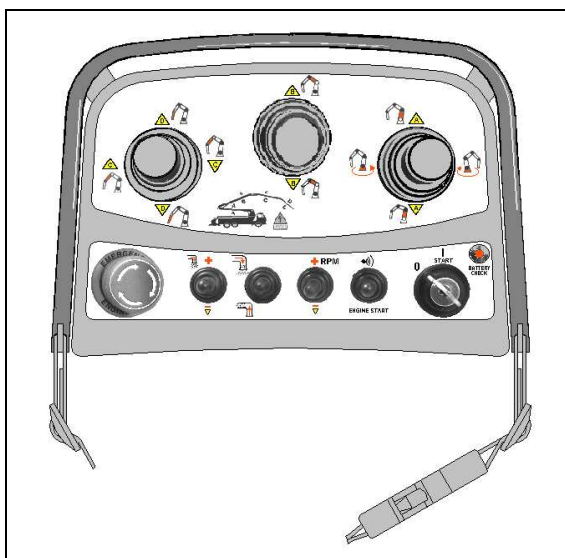

For boom operation follow the operations noted below precisely and in the correct order.

All of the boom movement functions are centralized on the handset control panel. Each function is indicated by a symbol that identifies the relative movement that is performed.

**SEZIONE B**  
*regole di sicurezza*  
*istruzioni per l'uso*

**SECTION B**  
*safety regulations*  
*instruction for use*

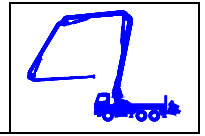

**1.** Azionare il primo elemento (A), in modo che tutti si sollevino di almeno 60°.  
 Il disinserimento automatico del gancio consente l'azione successiva.

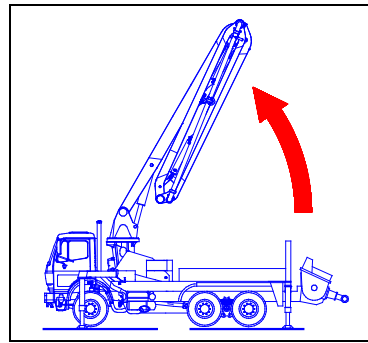
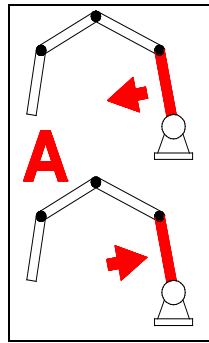

**1.** Activate the first element (A), so that the entire unit is raised by at least 60°.  
 The automatic release of the hook permits the successive operations to be carried out.

**2.** Azionare il secondo elemento (B) assieme al terzo e quarto ed aprirlo di almeno 120°.

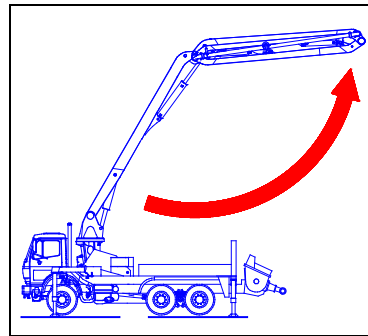
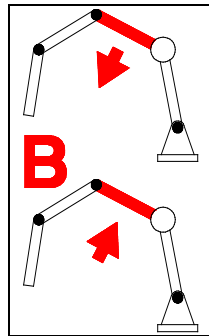

**2.** Activate the second element (B) together with the third and fourth, opening to at least 120°.

**3.** Azionare il comando di rotazione del braccio e muovere fino a portare il braccio nella direzione del campo operativo.

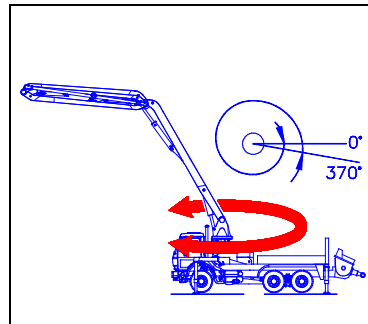
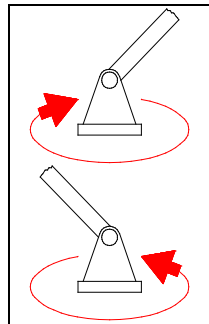

**3.** Activate the boom rotation control, moving the unit until in the direction of the operative working field.

**4.** Aprire il terzo elemento (C), di circa 180°.

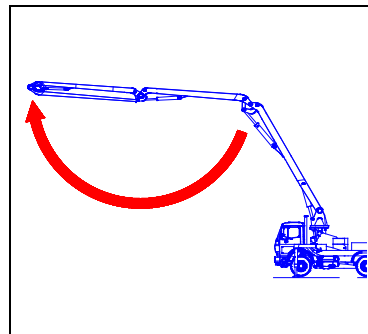
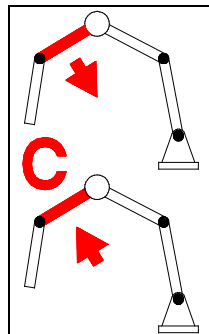

**4.** Open the third element (C) by approximately 180°.

**5.** Aprire il quarto elemento (D).

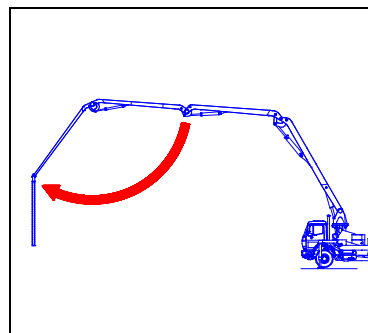
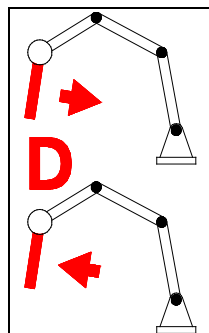

**5.** Open the fourth element (D).

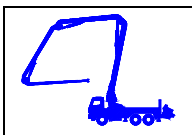

**SEZIONE B**  
*regole di sicurezza*  
*istruzioni per l'uso*

**SECTION B**  
*safety regulations*  
*instruction for use*

**Comandi d'emergenza**

Il distributore oleodinamico può essere utilizzato come comando d'emergenza per tutti i movimenti del braccio. Mentre la leva più corta all'estremità del distributore sostituisce l'interruttore per il consenso alle manovre degli stabilizzatori.

In corrispondenza alle leve di comando sono riportati tutti i simboli che identificano le varie funzioni, come sul telecomando.

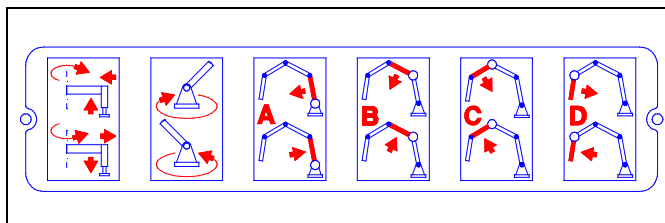

**Emergency controls**

The hydraulic distributor can be used as an emergency control of all boom movements, whereas the shortest lever, positioned at the end of the distributor, replaces the consensus switch for the stabilizer maneuvers.

Symbols that identify all of the various functions have been positioned in correspondence with the control levers, as on the handset control panel.

**ATTENZIONE!**

In seguito ad un urto subito accidentalmente dal braccio, far eseguire un controllo presso una officina autorizzata dalla *Waitzinger*.

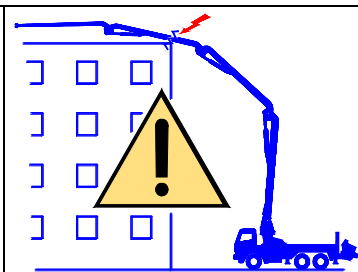

**WARNING**

In the event of the boom accidentally colliding against objects or buildings, a check-up should be made at an authorized *Waitzinger* service center.

E' vietato prolungare il braccio di distribuzione o il tubo terminale flessibile oltre la lunghezza specificata sulla targhetta dei dati di identificazione ed indicata mediante la segnaletica posta sulla macchina.

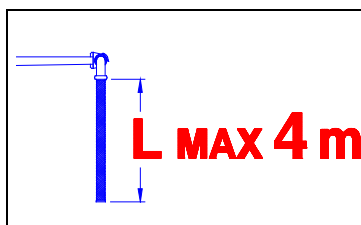

Extending the distributor boom or the flexible end hose beyond the distance specified on the data identification plate, and indicated on the signs applied to the machine, is strictly prohibited.

Il tubo terminale flessibile, nonchè una riduzione in collegamento con il tubo terminale flessibile deve sempre essere assicurato con collare e cavo d'acciaio.

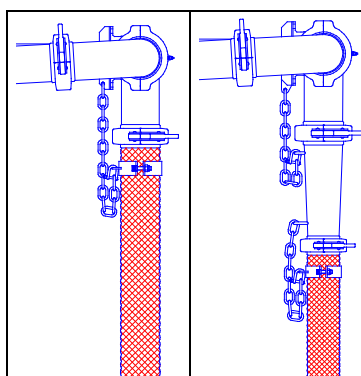

The flexible end hose, or any reduction connections that may be attached to the flexible end hose, must be secured by means of the collar and steel cable.

Se al terminale flessibile venissero allacciate altre tubazioni di mandata, queste non devono far gravare il loro peso sul braccio di distribuzione.

If other delivery piping is attached to the flexible end hose, the weight of this additional piping must not be sustained by the distributor boom.

**ATTENZIONE!**

**Mai** allacciare altre tubazioni al terminale flessibile del braccio.

**CAUSA DANNI AL BRACCIO!**

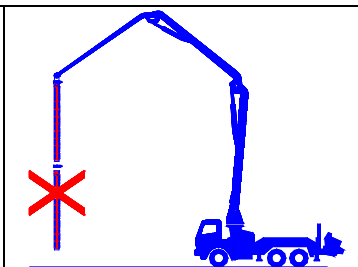

**CAUTION!**

**Never** add extensions to the end of the placing boom.

**POSSIBLE BOOM DAMAGE!**

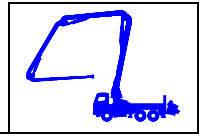

## **Fine del lavoro**

### **Chiusura del braccio:**

Alla fine del pompaggio il braccio di distribuzione deve essere appoggiato sul cavalletto, in ordine di marcia, eseguendo in ordine inverso le fasi descritte per l'apertura. Nella fase di rotazione del braccio prestare attenzione a non urtare la cabina dell'autoveicolo.

Nel caso di sospensione del lavoro, anche abbandonando la macchina per breve tempo, spegnere il motore ed assicurarla contro un eventuale utilizzo abusivo. Ad esempio chiudere a chiave il telecomando nella cabina.

Quando il braccio è chiuso e correttamente appoggiato sul cavalletto, viene attivato un microinterruttore installato all'estremità del cavalletto stesso, collegato a due spie di segnalazione poste sulla plancia di cabina.

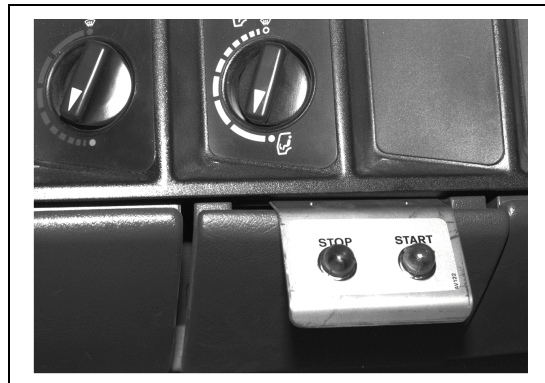

### ***SPIA VERDE* → START**

La spia verde accesa indica la corretta posizione del braccio sul cavalletto, dando quindi consenso alla marcia dell'autoveicolo.

### ***SPIA ROSSA* → STOP**

La spia rossa indica invece che il braccio non si trova nella posizione corretta di chiusura.

Effettuare un controllo visivo della posizione del braccio.

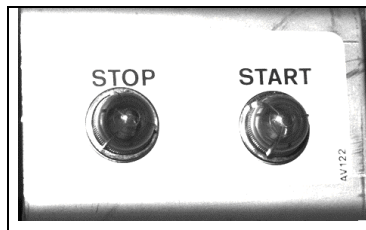

## **End of work**

### **Closing the boom:**

At the end of pumping operations the distributor boom must be positioned on the stand, ready for transport, following the same procedure that was described for opening operations, but in reverse order.

When rotating the boom take care not to collide against the vehicle cab.

In the event of work being suspended, or if the machine is to be left unattended - even for a short period of time, switch off the engine and make sure that the machine cannot be used by unauthorized personnel. For example, lock the handset control command panel inside the driver's cab.

When the boom has been correctly closed and is resting on the stand, a microswitch (fitted on the end of the stand), connected to two pilot lights located on the instrument panel in the driver's cab, will be activated.

### ***GREEN PILOT LIGHT* → START**

When the green pilot light is illuminated, the boom is correctly positioned on the stand, therefore the vehicle may be moved.

### ***RED PILOT LIGHT* → STOP**

When the red pilot light is illuminated, the boom is not in the correct closed position on the stand.

Visually check the position of the boom.

## **ATTENZIONE**

E' vietato spostare l'autoveicolo con il braccio di distribuzione aperto o con gli stabilizzatori non posizionati in ordine di marcia.

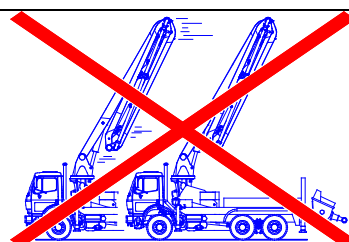

## **WARNING**

The vehicle must not be moved when the distributor boom is open or when the stabilizers are not in the transport position.

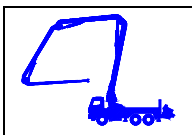

**SEZIONE B**  
*regole di sicurezza*  
*istruzioni per l'uso*

**SECTION B**  
*safety regulations*  
*instruction for use*

Assicurarsi che il tubo terminale flessibile sia correttamente bloccato alla struttura tramite gli appositi agganci. Inoltre, tutti gli accessori posti sulle pedane dovranno essere opportunamente collocati in modo da non essere dispersi lungo il tragitto della macchina.

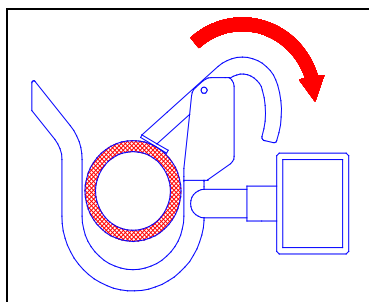

Make sure that the flexible end hose is correctly secured to the structure by means of the special hooks. All of the accessories fitted on the platform should be suitably secured, in order to prevent loss during transport.

**ATTENZIONE!**

Durante la marcia su strada, gli accessori, i tubi e altro materiale lasciato libero sulle pedane dell'autoveicolo, potrebbero cadere nella corsia di marcia.



**CAUTION!**

Accessories, piping or other material that is left free on the platform, may fall from the vehicle when traveling on the road.

**ATTENZIONE!**  
**PERICOLO per la VITA:**

Prima di mettersi in viaggio controllare che i dispositivi di fissaggio degli stabilizzatori siano stati attivati. Se tali dispositivi non sono funzionanti o risultano danneggiati l'AUTOVEICOLO NON DEVE CIRCOLARE fino ad avvenuta riparazione.

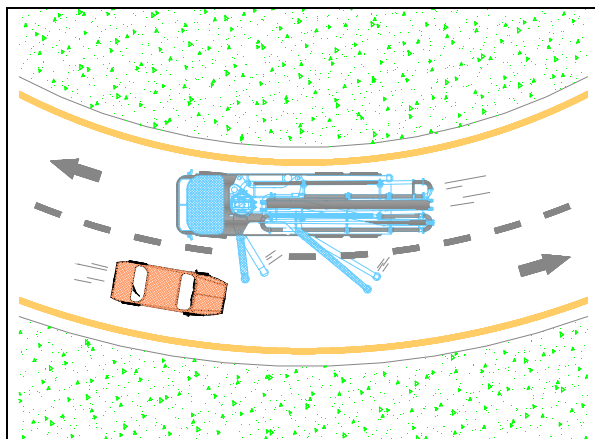

**CAUTION!**  
**DANGER OF LIFE:**

Be sure that stabilizers are pinned and locked before traveling. If the locking device is damaged or worn, you **MUST NOT DRIVE THE UNIT** until it is repaired.

**Lavaggio**

- La pulizia delle macchine non deve essere effettuato con soluzioni contenenti agenti chimici corrosivi, acidi ed alcali o solventi aggressivi che potrebbero danneggiare le superfici verniciate, cromate, e tutte le parti non metalliche.
- Mai tenere rivolto un getto d'acqua o di vapore verso persone, quadri di comando o componenti elettrici della macchina. Le parti elettriche potrebbero subire danni irreparabili.

**Washing**

- When cleaning the machine, do not use solutions that contain corrosive chemical agents, acids and alkalis or aggressive solvents that may damage the painted or chromed surfaces and all of the non-metal parts of the machine.
- Never direct jets of water or vapor towards personnel, control panels or electrical components on the machine. The electrical parts may be subject to irreparable damage.

**ATTENZIONE!**

**Pericolo di morte**  
a causa di passaggio di tensione !



**WARNING!**

**Death hazard**  
due to electrical current !

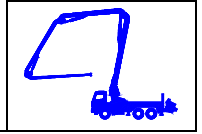

## **Lavoro notturno**

Durante il lavoro notturno, munirsi di luce di illuminazione per quadro comandi e telecomando (o radiocomando), e assicurarsi che tutto il campo operativo del braccio e relativa segnaletica, sia sufficientemente illuminata.

## **Night work**

When working at night, procure lighting for the control panel and handset control panel (or radio control panel), and make sure that boom field of operation and the relative signals are all sufficiently illuminated.



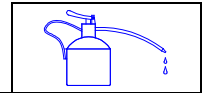

## Premessa

I bracci *Waitzinger*, dopo l'assemblaggio finale, vengono accuratamente sottoposti a lunghi test di collaudo e manovre nelle situazioni più gravose al fine di simulare le condizioni d'impiego. Ciò non toglie che inizialmente potrebbero verificarsi alcuni inconvenienti, dovuti essenzialmente alla presenza di impurità nei circuiti oleodinamici, o anomalie nei contatti e nel funzionamento degli apparati elettrici o elettronici.

Con la *sezione manutenzione* del presente manuale vengono descritte tutte le operazioni da effettuare alla macchina, suddividendole in tre parti:

- Manutenzione ordinaria
- Manutenzione straordinaria e riparazioni
- Soluzione di problemi

### Frequenza di manutenzione

Per frequenza di manutenzione si intende l'intervallo di tempo massimo ammesso per rieseguire la medesima operazione.

L'indicazione di tale intervallo di tempo, apparirà nelle pagine seguenti accanto alla descrizione di ciascuna operazione, inscritta in un simbolo ed espressa in ore di lavoro della macchina.

E' necessario effettuare alcuni controlli ogni qualvolta si intenda utilizzare la macchina e durante il suo uso. Per questi tipi di operazioni consideriamo che la frequenza di manutenzione sia giornaliera.

## Manutenzione ordinaria

La manutenzione ordinaria consiste nell'eseguire ad intervalli di tempo periodici tutte le regolari operazioni necessarie alla sicurezza di funzionamento degli apparati della macchina.

## Preface

After final assembly, all booms manufactured by the *Waitzinger* company undergo severe and prolonged trials and test maneuvers in heavy working conditions, in order to simulate the real conditions of use. However, initial problems may occur as a result of impurities in the hydraulic circuit or contact failures or electric or electronic component breakdown.

The *maintenance section* in this manual describes all of the operations that need to be performed on the machine, and is subdivided into three parts:

- Routine maintenance
- Extraordinary maintenance and repairs
- Troubleshooting

### Frequency of maintenance operations

The frequency of maintenance operations is referred to in terms of the maximum permissible time period between the repetition of the same operation.

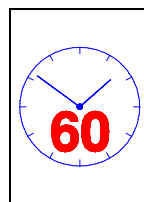

This time period, shown on the following pages next to the description of the operation in question, will be indicated by a symbol and expressed in machine working hours.

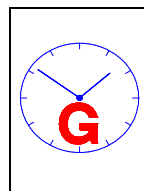

Certain checks will need to be performed each time the machine is required to be used and during use. This type of operation is considered to be on a daily basis.

## Routine maintenance

Routine maintenance consists of periodically following all of the regular operations that are necessary for the safety and operation of the machine equipment.

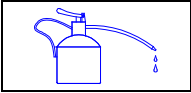

**SEZIONE C**  
*manutenzioni*

**SECTION C**  
*maintenance*

Le operazioni di manutenzione indicate in questa pagina, sono espone e illustrate dettagliatamente nelle pagine seguenti, riproponendo la descrizione dell'operazione e la corretta esecuzione dell'intervento.

The maintenance operations indicated on this page are explained in detail on the following pages, with a description of the operation and its correct execution.

<b>CONTROLLI GIORNALIERI</b>		<b>DAILY CHECKS</b>
<ul style="list-style-type: none"> <li>• Livello olio idraulico nel serbatoio.</li> <li>• Pressione d'esercizio impianto idraulico.</li> <li>• Livello olio al riduttore per rotazione.</li> </ul>		<ul style="list-style-type: none"> <li>• Hydraulic fluid tank level.</li> <li>• Hydraulic system operating pressure.</li> <li>• Rotation reduction unit oil level.</li> </ul>
<b>OGNI 60 ORE</b>		<b>EVERY 60 HOURS</b>
<ul style="list-style-type: none"> <li>• Indicatore di intasamento filtro olio.</li> <li>• Scaricare condensa dal serbatoio olio.</li> <li>• Lubrificare tutti i punti di snodo.</li> <li>• Ingrassare i giunti del calcestruzzo.</li> </ul>		<ul style="list-style-type: none"> <li>• Oil filter clogging indicator.</li> <li>• Drain off oil tank condensate.</li> <li>• Lubricate all articulated joints.</li> <li>• Grease the concrete delivery piping joints</li> </ul>
<b>OGNI 100 ORE</b>		<b>EVERY 100 HOURS</b>
<ul style="list-style-type: none"> <li>• Controllo serraggio flessibili e raccordi.</li> <li>• Lubrificare il cuscinetto per la rotazione.</li> <li>• Lubrificare l'ingranaggio della rotazione.</li> </ul>		<ul style="list-style-type: none"> <li>• Check the tightness of the unions and flexible hoses</li> <li>• Lubricate the rotation bearing.</li> <li>• Lubricate the rotation gears.</li> </ul>
<b>OGNI 500 ORE</b>		<b>EVERY 500 HOURS</b>
<ul style="list-style-type: none"> <li>• Sostituzione cartuccia del filtro olio.</li> <li>• Controllo serraggio cuscinetto rotazione.</li> <li>• Controllo serraggio viti e ghiera.</li> </ul>		<ul style="list-style-type: none"> <li>• Replace the oil filter cartridge.</li> <li>• Check rotation bearing tightness.</li> <li>• Check screws and ring nuts tightness.</li> </ul>
<b>OGNI 2000 ORE</b>		<b>EVERY 2000 HOURS</b>
<ul style="list-style-type: none"> <li>• Filtraggio o sostituzione olio idraulico.</li> <li>• Controllo usura cuscinetto rotazione.</li> <li>• Controllo gioco ingranaggio rotazione.</li> </ul>		<ul style="list-style-type: none"> <li>• Filter or replace hydraulic fluid.</li> <li>• Check rotation bearing wear.</li> <li>• Check rotation gears play.</li> </ul>
<b>ATTENZIONE</b>  Qualsiasi operazione di manutenzione deve essere effettuata con braccio chiuso e motore fermo.		<b>WARNING</b>  All maintenance operations must be carried out with the boom closed and the engine switched off.
<b>ATTENZIONE</b>  Per l'impianto idraulico e per la lubrificazione utilizzare solo prodotti idonei e con le caratteristiche indicate nella seguente tabella.		<b>WARNING</b>  Only use suitable products for the hydraulic system and for lubrication purposes (see characteristics noted on the Oil and Lubricants table).

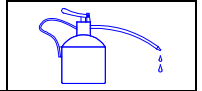

**Tabella oli e lubrificanti**

**Oil and lubricants table**

**OLIO IDRAULICO**  
Caratteristiche  
chimiche - fisiche - tecnologiche

**HYDRAULIC OIL**  
chemical - physical - technological  
characteristics

**MOBIL DTE 25**

**MOBIL DTE 25**

GRADAZIONE ISO	46
DENSITA' kg/dm <sup>3</sup>	0,875
POUR POINT °C	-30
FLASH POINT °C	225
VISCOSITA' cSt @ 40°C	43,5
VISCOSITA' ENG. @ 50°C	3,9
VISCOSITA' cSt @ 100°C	6,9
INDICE DI VISCOSITA'	115

ISO RATING	46
DENSITY kg/dm <sup>3</sup>	0,875
POUR POINT °C	-30
FLASH POINT °C	225
VISCOSITY cSt @ 40°C	43,5
ENG. VISCOSITY @ 50°C	3,9
VISCOSITY cSt @ 100°C	6,9
VISCOSITY INDEX	115

**CLASSIFICAZIONI**



**CLASSIFICATIONS**

DIN 51524	HLP
ISO 6743/4	L-HM
UNI 7164	HM
DENISON	HF-0

DIN 51524	HLP
ISO 6743/4	L-HM
UNI 7164	HM
DENISON	HF-0

**TABELLA COMPARATIVA**

**COMPARATIVE TABLE**

MARCA BRAND	Olio idraulico Hydraulic fluid	Olio per riduttore Reduction unit oil	Grasso per dentatura Grease	Grasso lubrificante Lubrificant grease
<b>MOBIL</b>	<b>DTE 25</b>	<b>MOBILGear 629</b>	 <b>MOBILTAC 81</b>	 <b>MOBILUX EP2</b>
<b>AGIP</b>	OSO 46	BLASIA 150		GRMU EP2
<b>ARAL</b>	Aral VITAM GF 46	DEGOL BG 150	ARALUB LFZ 1	ARALUB HLP 2
<b>BP</b>	ENERGOL HLP-HM 46	ENERGOL GR XP 150	ENERGOL WRL	GREASE LTX-EP2
<b>CHEVRON</b>	RPM EP hydraulic oil 46	GEAR Compound 150		DURALITH Grease EP2
<b>ESSO</b>	NUTO H 46	SPARTAN EP 150	SURETT FLUID 4 K	BEACON EP2
<b>FIAT</b>	HTF 46	EPZ 150		JOTA 2/S
<b>FINA</b>	HYDRAN 46	GIRAN 150		MARSON GPL 2
<b>IP</b>	HYDRUS oil 46	MELLANA 150	CLUSIUM FLUID D	ATHESIA EP2 Grease
<b>SHELL</b>	TELLUS oil 46	OMALA OIL 150	MALLEUS FLUID C	ALVANIA Grease 2
<b>TEXACO</b>	RANDO OIL HD CZ 46	MEROPA 150		MARFAX NP 2
<b>TOTAL</b>	AZOLLA ZS 46	CARTER EP 150 N		NYCTEA 2

L'ordine di elencazione dei lubrificanti non classifica la loro qualità.

The lubricants are not listed is order of quality.

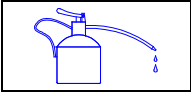

## Impianto idraulico

## Hydraulic system

- Controllare il livello dell'olio idraulico nel serbatoio.

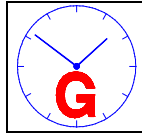

- Check the fluid level in the hydraulic fluid tank.

Per eventuali rabbocchi di olio servirsi dell'apposito tappo di riempimento con cestello di filtraggio, posto sulla parte superiore del serbatoio. Utilizzare solo olio del tipo indicato in tabella.

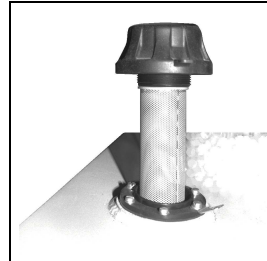
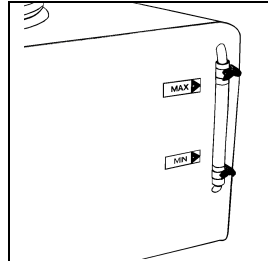

For eventual topping up use the filler cap, fitted with filter unit, positioned on the upper part of the tank. Only use fluids indicated on the Oil and Lubricants table.

- Tenere controllata la pressione di esercizio dell'impianto oleodinamico.

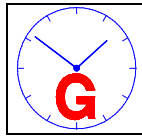

- Check the hydraulic system operating pressure.

### ATTENZIONE

Utilizzando la macchina in zone particolarmente calde o quando la temperatura dell'olio supera i 60°C, occorre inserire sul circuito uno scambiatore di calore. In tal caso sostituire l'olio idraulico ogni 2000 ore di lavoro.



### WARNING

If the machine is used in particularly hot environments or when the oil temperature exceeds 60° C, is required insertion of heat exchanger in the system. In this case the hydraulic fluid must be changed after every 2000 hours of work.

- Controllare il grado di intasamento della cartuccia del filtro dell'olio idraulico.

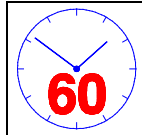

- Check the condition of the hydraulic fluid filtering cartridge.

Il filtro oleodinamico è munito di un indicatore di intasamento visivo, posto sul coperchio superiore dello stesso. Quando l'indicatore raggiunge il settore di colore rosso è necessario sostituire entro breve tempo la cartuccia del filtro.



The hydraulic filter is fitted with a visual clogging indicator, located on the upper cover of the filter. When the indicator reaches the red-colored sector the cartridge will need to be replaced.

- Scaricare l'eventuale condensa formatasi all'interno del serbatoio dell'olio idraulico.

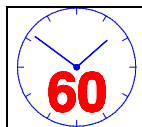

- Drain off any condensate that has formed inside the hydraulic fluid tank.

Per scaricare la condensa, le impurità depositate sul fondo o per vuotare completamente il serbatoio servirsi del rubinetto posto sul fondo del serbatoio stesso.

In order to drain off the condensate, the impurities deposited on the bottom or to completely empty the tank, use the cock fitted at the bottom of the tank itself.

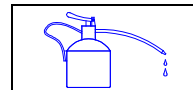

- Controllo serraggio flessibili e raccordi sull'intero circuito oleodinamico.

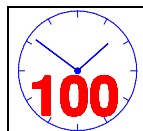

- Check the tightness of the flexible hoses and unions throughout the hydraulic circuit.

E' opportuno verificare che non ci siano perdite, lungo le tubazioni oleodinamiche, in corrispondenza dei collegamenti con i tubi flessibili; accertarsi del corretto serraggio tra raccordi, valvole e martinetti, pompa, serbatoio e distributore. Detti inconvenienti favoriscono l'ingresso di aria nel circuito causando "l'effetto diesel" dannoso per le guarnizioni dei cilindri. Per eliminare l'inconveniente intervenire come di seguito specificato:

1. Eliminare tutte le perdite di olio dal circuito oleodinamico.
2. Assicurarsi che la temperatura dell'olio non superi i 60°C.

3. Togliere tutta l'aria agendo sulle "valvole di sfiato aria" dei martinetti. Tale operazione va eseguita con il braccio appoggiato.

4. Eseguire alcune manovre di totale apertura e chiusura degli elementi del braccio per favorire la completa fuoriuscita di aria.

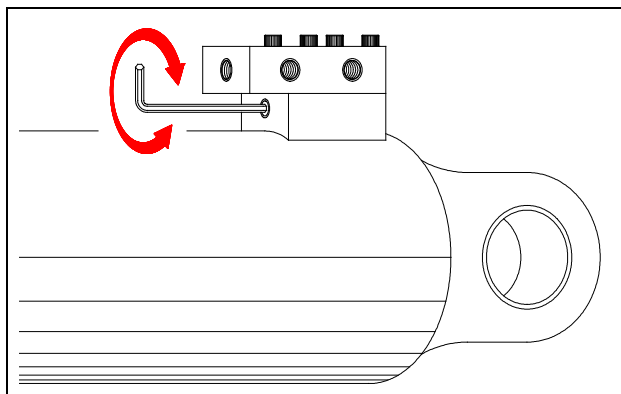

Check for leaks on the hydraulic tubes in correspondence with the connections with the flexible hoses. Make sure that the connections between the unions, valves and jacks, pump, tank and distributor are correctly tightened. These problems favour entrance of air into the circuit, leading to a "Diesel effect" which is harmful for the cylinder lining. In order to solve this problem, proceed as follows:

1. Eliminate all oil leakages on the hydraulic circuit.
2. Make sure that the temperature of the oil does not go over 60°C.

3. Take all the air out, operating on the "air vent valves" of the jacks. This operation must be performed with the boom down.

4. Perform some total opening and closing operations on the boom elements, in order to help all the air come out.

### ATTENZIONE

Utilizzare l'attrezzatura con componenti dell'impianto oleodinamico in avaria compromette l'efficienza e la sicurezza della macchina.



### WARNING

Using the equipment with defective hydraulic system components puts the efficiency and safety of the machine at risk.

### Tubi flessibili per impianto oleodinamico

I tubi flessibili KOMPAKT installati sulla macchina sono prodotti dalle elevate caratteristiche. Poiché si tratta di materiale destinato ad usurarsi dovranno essere sostituiti almeno ogni sei anni.

### Flexible hoses for the hydraulic system

The KOMPAKT flexible hoses that have been fitted on the machine are high performance products. As this material is subject to wear, it is advised to replace the hoses at least every six years.

### ATTENZIONE

Non utilizzare tubazioni flessibili se conservate in magazzino per più di due anni. La prolungata giacenza riduce la proprietà del flessibile di resistere alle elevate pressioni.



### WARNING

Do not use flexible hoses that have been kept in storage for more than two years. Prolonged inactivity reduces the hose's capacity to sustain high pressures.

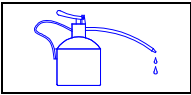

## SEZIONE C manutenzioni

## SECTION C maintenance

Quando si ritiene opportuno sostituire i flessibili è necessario adottare alcune precauzioni, in particolare nelle fasi di montaggio. I flessibili devono permettere eventuali spostamenti dei componenti oleodinamici a cui sono collegati, senza essere sottoposti a sforzi di trazione, torsione o costretti in posizioni che richiedono al tubo un raggio di curvatura minore del limite ammesso in funzione delle dimensioni stesse. Di seguito alcuni esempi.

Certain precautions must be taken when replacing the flexible hoses, especially during assembly operations. The flexible hoses must permit the hydraulic components, to which they are connected, to move, without enduring tractive force, torsion or creating curves that require a radius of curvature less than the limit allowed by dimensions of the hose itself. See the examples listed below.

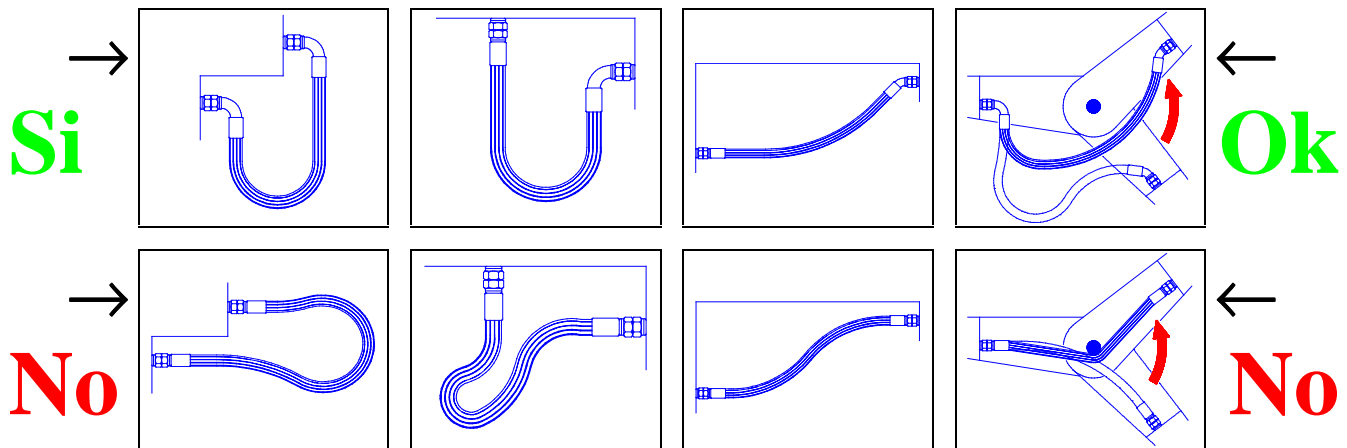

**Tabella tubi flessibili**

**Flexible hose table**

Diametro interno	pollici	1/4	5/16	3/8	1/2	3/4	1	inches	Internal diameter
	mm.	6,35	7,93	9,52	12,7	19,05	25,4	mm.	
Diametro esterno	sulla gomma	13,5	15	17,6	20,6	27,7	35,6	rubber	External diameter
	sulla treccia	11,2	12,9	15,6	18,4	25,5	33,4	plait	
Pressioni (bar)	di lavoro	412	400	375	300	237	180	working	Pressure (bar)
	di prova	825	800	750	600	475	360	test	
	di scoppio	1650	1600	1500	1200	950	720	bursting	
Raggio di curvatura minimo	mm.	70	80	90	120	160	200	mm.	Minimum radius of curvature

### ATTENZIONE

Si deve assolutamente evitare la saldatura dei raccordi, la verniciatura dei tubi flessibili e il loro sfregamento contro parti rigide.



### WARNING

Unions should never be welded, flexible hoses should not be painted and should not rub against rigid parts.

### Raccordi per impianto oleodinamico

I raccordi completi o i componenti utilizzati per l'assemblaggio dei circuiti oleodinamici sono intercambiabili con raccordi di altre marche a condizione che siano costruiti in conformità alle norme DIN 2353.

### Unions for hydraulic systems

Complete unions or the components used for the assembly of hydraulic circuits, are interchangeable with unions of different brands, on the condition that they have been manufactured in accordance with DIN 2353 regulations.

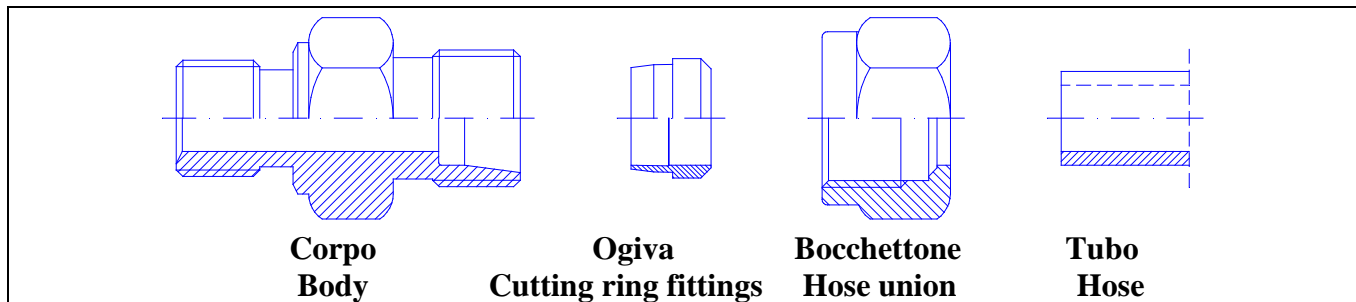
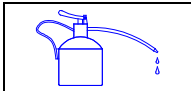

L'ogiva penetra nel tubo ad una profondità limitata, scivola facilmente lungo la superficie del bocchettone, assicurando la tenuta ermetica. L'elasticità delle ogive impedisce l'allentamento del dado di bloccaggio, anche in presenza di forti sollecitazioni.

The ogive enters the tube to a limited depth, it slides smoothly on the surface of the hose union, guaranteeing the hermetic seal. The elasticity of the ogive prevents the lock nut from loosening, even when under elevated stress levels.

**1.** Tagliare il tubo perpendicolarmente all'asse e sbavare i bordi. Pulire il tubo da eventuali scorie di lavorazione. Lubrificare la filettatura, l'ogiva ed il cono del corpo del raccordo. Non utilizzare grasso.

**1.** Cut the hose perpendicular to the axis and trim the edges. Carefully clean the hose. Lubricate the thread, ogive and union body cone. Do not use grease.

**2.** Infilare il bocchettone e l'ogiva sul tubo. Premere l'estremità del tubo contro la battuta d'arresto del corpo.

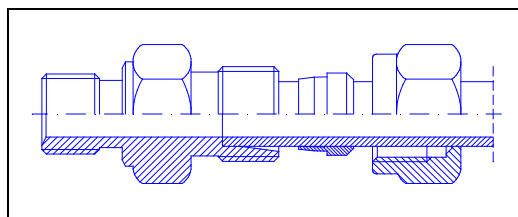

**2.** Slide the union and the ogive onto the hose. Press the end of the hose against the stop fitted in the body.

**3.** Avvitare il bocchettone di circa un giro e mezzo affinché l'ogiva produca una tacca visibile sul tubo.

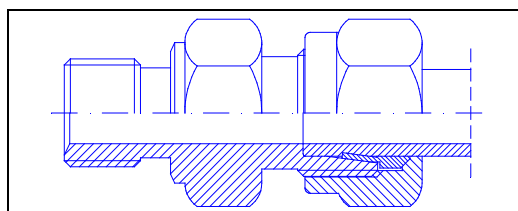

**3.** Tighten the union by approximately one and a half turns, until the ogive produces a visible notch on the hose.

**4.** Svitare il bocchettone, controllare che l'accoppiamento sia perfetto e quindi serrare definitivamente con la chiave rispettando la coppia di serraggio.

**4.** Unscrew the union, check that the connection is perfect then fully tighten, using a wrench, respecting the torque wrench setting.

**Tabella coppie di serraggio**

**Torque wrench setting table**

<b>DIAMETRO NOMINALE</b>	8	10	12	15	15	18	25	30	<b>NOMINAL DIAMETER</b>
<b>CHIAVE</b>	14	19	22	24	27	27	41	50	<b>WRENCH</b>
<b>COPPIA DI SERRAGGIO in Nm</b>	20	50	90	90	110	110	200	300	<b>TORQUE WRENCH SETTING in Nm</b>

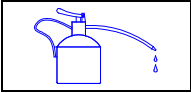

## SEZIONE C manutenzioni

## SECTION C maintenance

### Pulizia dell'impianto oleodinamico

- Sostituzione della cartuccia del filtro posto sul serbatoio dell'olio idraulico.

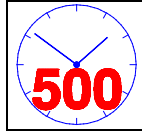

Per sostituire la cartuccia togliere il coperchio del filtro. Utilizzare la cartuccia con grado di filtraggio di 25 µ assoluti.

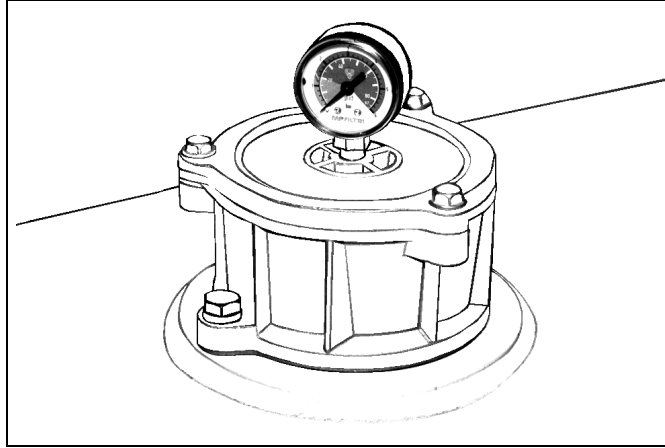

In order to replace the cartridge remove the filter cover. Use a cartridge with a 25 µ absolute filtering degree.

- Filtraggio olio o sostituzione completa.



Filtrare tutto l'olio idraulico presente nell'impianto della macchina attraverso un'apposita centralina, contenendo il grado di filtraggio entro i 10 µ. Curare particolarmente la pulizia del serbatoio effettuabile attraverso il portello d'ispezione.

- Replace the filtering cartridge fitted on the hydraulic fluid tank.

- Filtering operation or complete oil change.

Filter all of the hydraulic fluid in the machine system through a special gearcase, with a filtering degree within 10 µ. Carefully clean the tank. Access can be gained to the inside of the tank by means of the inspection door.

**Totale capacità dell'impianto oleodinamico circa 350 litri.**

**Total capacity of hydraulic system: about 350 liters.**

### **ATTENZIONE**

L'intervento di sostituzione dell'olio va effettuato con il braccio chiuso e appoggiato sul cavalletto.



### **WARNING**

Supports should be positioned under the boom elements when oil change are required to be performed.



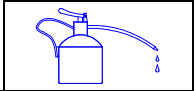

### Punti di lubrificazione

### Lubrication points

- Ingrassare tutti i punti di snodo della macchina come indicato nei seguenti schemi.

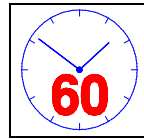

- Grease all of the articulated joints on the machine, as shown in the diagram.

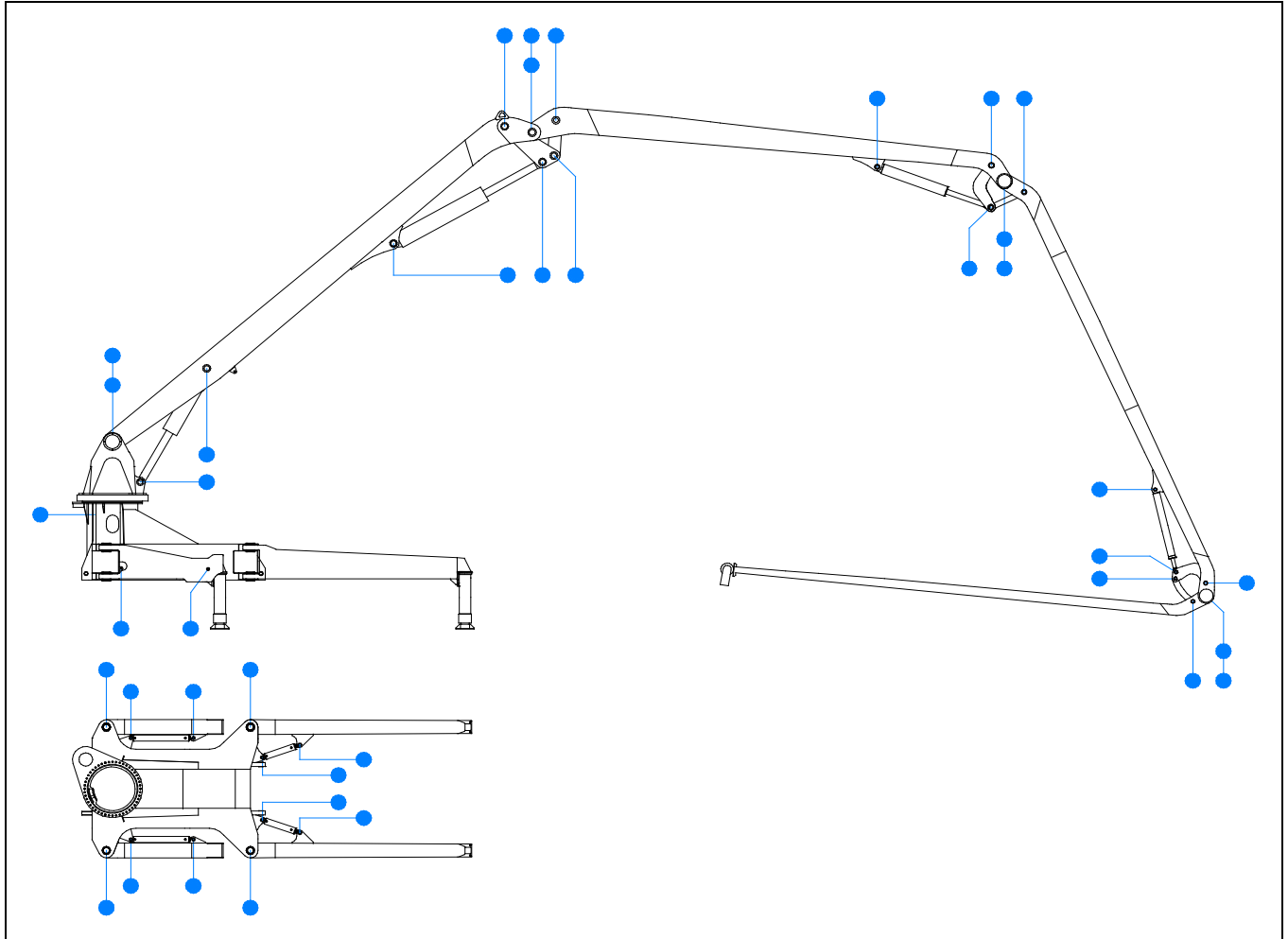

- Ingrassare i giunti soggetti a rotazione sulla tubazione del calcestruzzo.

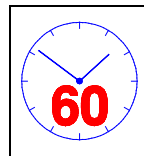

- Grease the rotating joints on the concrete delivery piping.

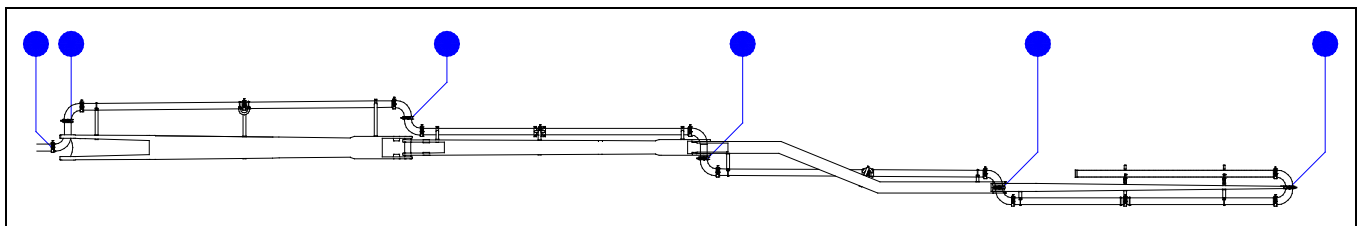

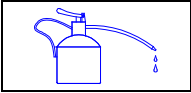

**Gruppo rotazione**

- Controllare il livello dell'olio di lubrificazione per il riduttore della rotazione del braccio.

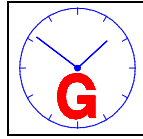

**Rotation unit**

- Check the lubrication oil level of the boom rotation reduction unit.

**Capacità totale olio: 5,6 litri.**

**Total capacity of oil: 5,6 liters.**

Effettuare gli eventuali rabbocchi d'olio, utilizzando solamente olio del tipo indicato nella tabella.

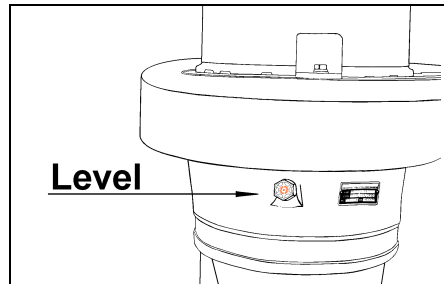

For eventual topping up, only use oils indicated on the Oil and Lubricants table.

- Lubrificazione del cuscinetto di rotazione del braccio.
- Lubrificazione della dentura.

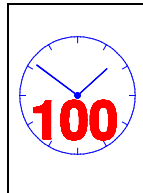

- Lubricate the boom rotation bearing.
- Lubricate the teeth.

L'ingrassaggio serve a ridurre l'attrito, fare tenuta e protegge dalla corrosione. Il grasso deve fuoriuscire dalle guarnizioni. Per la scelta dei lubrificanti vedere tabella.

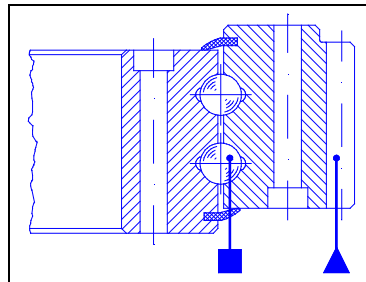

Greasing serves to reduce friction, maintain the seal and protect from corrosion. The grease should be injected until it is made to exit from the gasket. See the table for the selection of the lubricant.

**ATTENZIONE**

L'impiego di prodotti aggressivi per il lavaggio o prodotti non idonei per la lubrificazione altera le proprietà del grasso, corrodendo le piste di rotolamento e danneggiando i distanziali.



**WARNING**

The use of aggressive cleaning products or unsuitable lubrication products alters the properties of the grease, thereby corroding the rolling track and damaging the spacers.

**ATTENZIONE**

Prima e dopo un lungo periodo di inattività è assolutamente necessaria la lubrificazione del cuscinetto. Si raccomandano lubrificazioni più frequenti in ambienti tropicali, in luoghi polverosi, umidi o soggetti a forti sbalzi termici.



**WARNING**

Before and after long periods of inactivity the bearing will need to be lubricated. Lubrication should be carried out more frequently in tropical climates, dusty or damp environments or areas that are subject to notable changes in temperature.

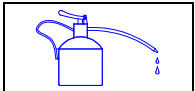

- Controllo del serraggio dei bulloni sul cuscinetto di rotazione del braccio.

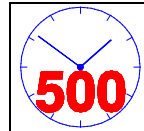

- Check the tightness of the bolts on the boom rotation bearing.

Durante questa operazione il collegamento bullonato deve essere scaricato dalle sollecitazioni a trazione provocate dal braccio. Occorre quindi sistemare il braccio nella posizione di marcia appoggiato sul cavalletto. Il serraggio deve essere eseguito intervenendo sulle viti a due a due diametralmente opposte.  
Per coppia di serraggio vedi tabella.

During this operation the tensile stress caused by the boom must be released from the bolted connection.  
The boom should be placed in the transport position on the stand.  
Tightening should be carried out on diametrically facing bolts, two by two.  
See the table for the relevant torque wrench settings.

Diametro della vite →		M16	M18	M20	M22	M24	M27	M30	← Screw diameter	
COPPIA DI SERRAGGIO daNm	VITE CLASSE 8.8	19	27	38	52	66	99	135	SCREW CLASS 8.8	TORQUE WRENCH SETTING daNm
	VITE CLASSE 10.9	27	38	55	74	95	139	189	SCREW CLASS 10.9	

- Controllo dell'usura del cuscinetto di rotazione del braccio.

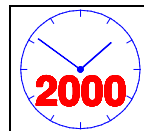

- Check the wear condition of the boom rotation bearing.

L'usura del sistema di rotolamento è rilevabile dall'aumento del gioco tra i corpi volventi e gli anelli del cuscinetto. Tale gioco comporta l'abbassamento dell'anello superiore del cuscinetto in direzione del carico, dando origine a due misure di altezza, dette minima e massima.

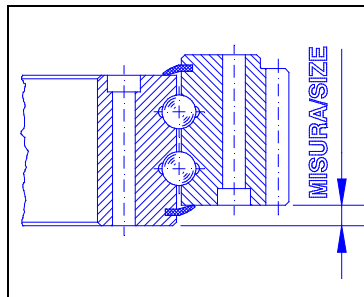

The wear of the rolling system can be detected by the increased play between the revolving body and the bearing rings. This play leads to the lowering of the upper bearing ring towards the load, providing two measurements of height, called minimum and maximum.

L'operazione deve essere eseguita posizionando la macchina come illustrato. Dalle misure di altezza minima e massima, effettuate nei due punti diametralmente opposti, si ricava il valore del gioco del cuscinetto.

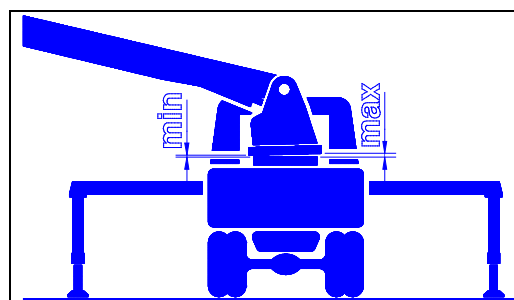

This operation should be carried out with the machine positioned as in the drawing. From the minimum and maximum height measurements, taken at two diametrically facing points, the bearing play value can be determined.

Nella seguente tabella è indicato, in funzione del diametro della pista di rotolamento e del diametro delle sfere, il massimo incremento ammissibile del gioco fra l'anello interno e esterno, rispetto al gioco originale. Tali valori indicano il limite massimo di usura del cuscinetto.

Based on the diameter of the rolling track and the diameter of the balls, the following table indicates the maximum admissible increase in play between the inner and outer ring, in relation to the original play value. These values indicate the maximum wear limits of the bearing.

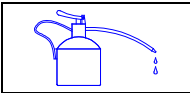

## SEZIONE C manutenzioni

## SECTION C maintenance

Diametro pista di rotolamento fino a mm.	Diametro delle sfere			Ball diameter		Rolling track diameter up to mm.
	20	22	mm. 25	30	40	
1000	1,8	1,9	1,9	2,0	2,5	1000
1250	1,9	2,0	2,0	2,1	2,6	1250
1500	2,0	2,1	2,1	2,2	2,7	1500
1750	-	2,2	2,2	2,3	2,8	1750
2000	-	-	2,3	2,4	2,9	2000
2250	-	-	-	2,5	3,0	2250
2500	-	-	-	-	3,1	2500

- Controllo del gioco dell'ingranaggio di trasmissione della rotazione.



- Check the play on the rotation transmission gear.

Per ridurre il gioco tra pignone e il cuscinetto dentato eseguire le seguenti operazioni:

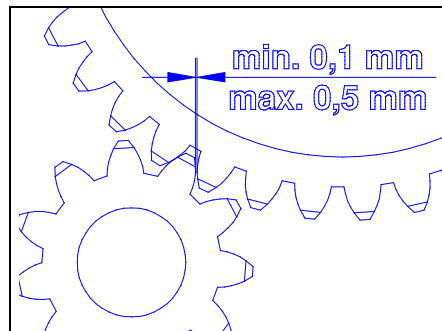

In order to reduce the play between the pinion and the toothed bearing, proceed as follows:

1. Disporre il pacchetto braccio in posizione verticale.
2. Misurare il gioco tra la dentature.
3. Scollegare le viti del motoriduttore.
4. Smontare il riduttore.
5. Sfilare la flangia eccentrica e farla ruotare di uno o più fori in senso orario secondo il gioco da eliminare. Lo spostamento di un foro avvicina il pignone di circa 0,15 mm.
6. Rimontare il riduttore rispettando la tabella delle coppie di serraggio per le viti.

1. Place the boom unit in the vertical position.
2. Measure the play between the tothing.
3. Disconnect the screws from the reduction unit.
4. Disassemble the reduction unit.
5. Extract the eccentric flange, rotating it in a clockwise direction by one or more holes, depending on the play that is to be eliminated. Moving by one hole allows the pinion to approach by approximately 0.15 mm.
6. Reassemble the reduction unit, respecting the screw torque wrench settings.

### Controlli generici

- Controllo serraggio viti.



E' opportuno effettuare periodicamente un controllo atto a verificare se le varie viti o ghiera non presentino allentamenti.

### General checks

- Check the tightness of the screws.

Periodical checks should be made to check that the various screws or ring nuts are suitably tightened.

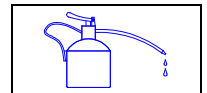

## Manutenzione straordinaria

Le operazioni di manutenzione straordinaria, come può essere il riequipaggiamento di parti di macchina, la saldatura e riparazione al braccio distributore, o a tutti i gruppi costruttivi, agli elementi portanti, al fissaggio degli stabilizzatori, al telaio o a parti conducenti pressione, devono essere eseguite solo da persone autorizzate dal costruttore.

La corretta esecuzione dei lavori di manutenzione straordinaria deve essere in ogni caso collaudata da un esperto in materia, nel rispetto delle disposizioni emanate per la prevenzione degli infortuni sul lavoro ( DPR N°547 del 27/04/1955 ) o le leggi del rispettivo paese di destinazione della macchina. Si richiama espressamente l'attenzione ad effettuare sempre riparazioni a regola d'arte.

- Il radio o telecomando deve essere disinserito ed inoltre il tasto funzione, **ARRESTO DI EMERGENZA** deve essere premuto. Durante le interruzioni del lavoro, si deve chiudere a chiave il radio-telecomando (ad esempio nella cabina dell'operatore o nella cassetta porta attrezzi) per proteggerlo da ogni abuso.

## Extraordinary maintenance

Extraordinary maintenance operations, as well as re-equipping parts of the machine, welding and repairing the distributor boom, or all of the construction units, the load bearing elements, the fixing of the stabilizers, to the chassis or to pressure conducting parts, should only be carried out by personnel authorized by the manufacturer.

Correct execution of extraordinary maintenance operations must always be tested by an expert in this particular field, in accordance with the regulations issued for the prevention of accidents at work (DPR No. 547 of 27/04/1955) or the laws in the countries where the machine is to be used. It is highly recommended that all repairs are carried out in a workmanlike manner.

- The remote or radio control must be disconnected and the **EMERGENCY STOP** push button must be pressed down. During work interruptions keep the handset control panel under lock and key (e.g.: inside the driver's cab or in the tool box), in order to prevent by unauthorized personnel.

### ATTENZIONE

Durante le interruzioni per le operazioni di riparazione, il cavo di collegamento del telecomando deve essere scollegato.



### WARNING

During work interruptions for repair purposes, the handset control panel connection lead should be disconnected.

### ATTENZIONE

E' vietato saldare con accumulatori di corrente collegati. In caso contrario le apparecchiature elettroniche verrebbero danneggiate irreparabilmente.

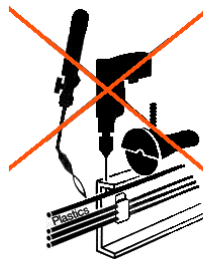

### WARNING

Welding must not be carried out with current accumulators connected as this would lead to irreparable damage to the electronic equipment.

- Per scollegare la batteria è sufficiente disinserire, quando presente, il sezionatore generale dell'impianto solitamente installato accanto alla batteria stessa. Altrimenti scollegare la batteria staccando i morsetti di entrambe le polarità.

- In order to disconnect the battery simply disconnect the system mains switch (if present) which is normally located next to the battery itself. Otherwise disconnect the battery by removing the terminals at both poles.

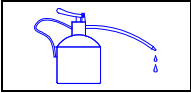

**SEZIONE C**  
**manutenzioni**

**SECTION C**  
**maintenance**

- Su macchine con equipaggiamento elettrico, come radiocomando (ricevitore), amplificatore ad intermittenza, e simili, tali apparecchiature devono essere disconnesse prima di iniziare i lavori di saldatura elettrica.

- On machines with electrical equipment, such as radio controls (receivers), intermittence amplifiers, etc. these devices must be disconnected before beginning electrical welding operations.

<p><b>INFIAMMABILI</b> <b>PERICOLO DI ESPLOSIONE</b> Particolare attenzione va dedicata al castello ed agli stabilizzatori che sono predisposti come serbatoio d'olio idraulico o di gasolio.</p>			<p><b>INFLAMMABLE</b> <b>DANGER OF EXPLOSION</b> Particular care must be taken with the turret and stabilizers, as they house hydraulic fluid or gasoil tanks.</p>
---	--	--	--

- Eliminazione di guasti, riparazioni ed operazioni di manutenzione devono essere effettuati solo a motore di comando arrestato, gruppi idraulici e tubazioni di mandata senza pressione.
- **Disinserire la chiave di avviamento.**
- Quando vengono sostituiti i componenti dei gruppi di comando è necessario attenersi ai dati tecnici della scheda macchina, e registrare su quest'ultima l'avvenuta sostituzione.
- Prima di smontare i componenti fare attenzione alla loro posizione di e rimontarli correttamente con l'ausilio delle indicazioni proposte in questo manuale nella sezione ricambi.
- Interventi di riparazione su valvole, cilindri o dispositivo di rotazione, possono essere effettuati solo con macchina livellata e braccio appoggiato su cavalletto. Con la macchina inclinata il braccio potrebbe girare anche se appoggiato.

- The elimination of faults, repairs and maintenance operations should only be carried out with the control motor stopped and without pressure in hydraulic units and delivery tubes.
- **Remove the ignition key.**
- If control unit components require replacement, the machine technical data card must be respected, and all replacements must be noted on this card.
- Before disassembling components, note their exact position and reassemble correctly with the help of the indications contained in the spare parts section of this manual.
- Repair operations on valves, cylinders or rotation devices, should only be carried out with the machine positioned on a flat surface and with the boom resting on the stand. If the machine is positioned on a slope the boom could rotate even if resting on the stand.

<p><b>ATTENZIONE</b> Sostenere gli elementi del braccio, ogni qualvolta si eseguano interventi di riparazione e manutenzione.</p>		<p><b>WARNING</b> Supports should be positioned under the boom elements when repair or maintenance operations are required to be performed.</p>
---	--	---

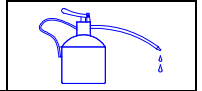

## Soluzione di problemi

## Troubleshooting

### 1. *Una sola funzione del braccio non risponde al telecomando.*

- **CAUSE:**
  - Interruzione di un cavo elettrico.
  - Il solenoide non funziona.
  - Elettronica fuori uso.
- **RIMEDI:**
  - Ripristinare il collegamento.
  - Sostituire il solenoide.
  - Sostituire l'elettronica.

### 1. *A single boom function fails to respond to the handset.*

- **CAUSE:**
  - Interruption of a power lead.
  - The solenoid is not working.
  - Faulty electronics.
- **REMEDY:**
  - Re-establish connection.
  - Replace the solenoid.
  - Replace electronics.

### 2. *Un elemento del braccio scende anche quando non viene azionato.*

- **CAUSA:**
  - Valvola di non ritorno sporca.
- **RIMEDIO:**
  - Pulire la valvola sul martinetto. Tale operazione va eseguita da un tecnico. Tarare la valvola dopo la pulizia. La pressione di taratura è stampigliata sul corpo valvola.
  - Se ciò non risolve il problema sostituire la valvola.

### 2. *A section of the arm drops despite not being activated.*

- **CAUSE:**
  - Non-return valve dirty.
- **REMEDY:**
  - Clean the valve at the jack. This operation should be performed by a skilled technician. Set the valve after cleaning. The pressure to be set is printed on the valve body.
  - If this does not solve the problem, replace the valve.

### 3. *Il circuito idraulico del braccio non va in pressione qualunque comando venga azionato.*

- **CAUSE:**
  - Pompa oleodinamica non innestata.
  - Saracinesca della linea aspirazione pompa, erroneamente chiusa.
  - Mancanza di olio idraulico.
  - Mancanza di corrente all'elettrovalvola dell'emergency-stop o solenoide non funzionante.
  - Relè posto nel quadro comandi non funzionante.
  - Cavi elettrici scollegati.
- **RIMEDI:**
  - Innestare la pompa oleodinamica.
  - Aprire la saracinesca.
  - Verificare che l'emergency-stop posto a bordo macchina (sul quadro comandi del braccio) sia disattivata ed il cavo del telecomando ben collegato alla spina.

### 3. *The boom hydraulic circuit fails to pressurize regardless of the control that is activated.*

- **CAUSE:**
  - Hydraulic pump not on.
  - Gate valve in pump suction pipe closed.
  - Lack of hydraulic fluid.
  - No power at emergency stop solenoid valve or solenoid valve defective.
  - Relay on control panel not operating.
  - Power leads disconnected.
- **REMEDY:**
  - Start the hydraulic pump.
  - Open the gate valve.
  - Check the emergency stop on board machine ( on the boom control panel) is not engaged and that the handset lead is plugged in.

### 4. *Il braccio si muove a scatti e/o irregolarmente.*

- **CAUSA:**
  - Presenza di aria nel circuito oleodinamico.
- **RIMEDIO:**
  - Eseguire qualche fine corsa dei movimenti di salita e discesa fino alla fuoriuscita di tutta l'aria.

### 4. *The boom moves in jerks and/or irregularly.*

- **CAUSE:**
  - Insufficient fluid or air in the hydraulic circuit.
- **REMEDY:**
  - Check level of oil sump. Increase the rpm of the hydraulic pump.



## SEZIONE C manutenzioni

## SECTION C maintenance

### 5. *La rotazione non si muove dal telecomando.*

● **CAUSE:**

- Interruzione di un cavo elettrico.
- Guasto al solenoide.
- Elettronica fuori uso.

● **RIMEDI:**

- Ripristinare il collegamento.
- Sostituire il solenoide.
- Sostituire l'elettronica.

### 5. *Handset fails to control rotation.*

● **CAUSE:**

- Electric cable interrupted.
- Solenoid not working.
- Faulty electronics.

● **REMEDY:**

- Reinstall cable.
- Replace solenoid.
- Replace electronics.

### 6. *La rotazione è lenta ed in certe posizioni si ferma.*

● **CAUSE:**

- Mancanza di pressione idraulica.
- Motore idraulico usurato.
- Macchina non livellata.
- Ralla non lubrificata.

● **RIMEDI:**

- Controllare la taratura delle valvole applicate al motore.
- Sostituire il motore idraulico.
- Livellare la macchina in bolla.
- Lubrificare la ralla.

### 6. *Rotation is slow and in certain positions the boom stops completely.*

● **CAUSE:**

- Lack of hydraulic pressure.
- Worn hydraulic motor.
- Machine not level.
- Fifth wheel not lubricated.

● **REMEDY:**

- Check motor valve setting.
- Replace hydraulic motor.
- Level the machine.
- Lubricate fifth wheel.

### 7. *Il braccio ruota senza essere azionato*

● **CAUSE:**

- Contatto elettrico nel comando a distanza.
- Usura del freno del riduttore.

● **RIMEDI:**

- Eliminare il contatto elettrico.
- Sostituire il freno.

### 7. *The boom rotates without having been activated.*

● **CAUSE:**

- Power contact in remote control.
- Reduction unit brake worn.

● **REMEDY:**

- Eliminate power contact.
- Replace brake.

### 8. *Il martinetto dello stabilizzatore non tiene la posizione (rientra).*

● **CAUSE:**

- Valvola di blocco usurata.
- Guarnizioni del martinetto usurate.
- Cilindro ovalizzato.

● **RIMEDI:**

- Sostituire valvola di blocco.
- Sostituire guarnizioni martinetto o/e cilindro

### 8. *Stabilizer jack fails to maintain position (re-enters).*

● **CAUSE:**

- Worn lock valve.
- Worn jack gaskets.
- Ovalized cylinder.

● **REMEDY:**

- Replace lock valve.
- Replace jack and/or cylinder gaskets.

### 9. *Rilevanza di rumori anomali dai cinematismi.*

● **CAUSE:**

- Lubrificazione mancante o non sufficiente.
- Attriti nello snodo delle curve del calcestruzzo.

● **RIMEDI:**

- Lubrificazione nei punti di ingrassaggio.
- Smontaggio giunto, lubrificazione e sostituzione guarnizione.

### 9. *Noises in kinematic mechanisms.*

● **CAUSE:**

- Lack of or poor lubrication.
- Friction in concrete curve articulated joints.

● **REMEDY:**

- Lubricate as indicated in section C of the manual.
- Disassemble joint, lubricate and replace gasket.





**10. All'inserimento della chiave nel quadro, l'impianto elettrico non va in tensione.**

- **CAUSE:**
- Fusibile sul quadro non funziona.
- Contatti ossidati nel blocchetto chiave.
- **RIMEDI:**
- Inserire un nuovo fusibile di amperaggio equivalente.
- Sostituire blocchetto con chiave.

**10. When key is inserted in panel, the electrical system fails to start up.**

- **CAUSE:**
- Fuse on panel not working.
- Oxidized key housing.
- **REMEDY:**
- Insert new fuse with the same amperes value.
- Replace housing and key.

**11. Il braccio diminuisce la velocità di tutti i movimenti, aumenta la temperatura dell'olio occorre aumentare i giri del motore per ottenere il sollevamento prescritto.**

- **CAUSA:**
- Pompa idraulica usurata.
- **RIMEDIO:**
- Verificare la pressione sulla mandata della pompa, se necessario sostituirla.

**11. Boom movement speed decreases, oil temperature increases, engine revs have to be increased in order to perform lifting operation.**

- **CAUSE:**
- Worn hydraulic pump.
- **REMEDY:**
- Check pressure on pump delivery and if necessary replace.

**12. Il braccio non si solleva con nessuno dei movimenti.**

- **CAUSA:**
- Valvola di sovrappressione generale, usurata, non fa più tenuta, oppure sporca.
- **RIMEDI:**
- Pulizia della valvola.
- Se usurata sostituirla.

**12. The boom completely fails to lift.**

- **CAUSE:**
- Overpressure valve worn. Seal is no longer holding or it is dirty.
- **REMEDY:**
- Clean the valve.
- If worn, replace.

**13. Rinvenimento di particelle metalliche nelle cartucce dei filtri dell'olio.**

- **CAUSA:**
- Vi sono parti nel circuito idraulico in fase di deterioramento.
- **RIMEDIO:**
- Individuare la parte in avaria (di solito è la pompa oleodinamica) provvedere alla sua sostituzione. Sostituire anche la cartuccia del filtro oleodinamico.

**13. Metal particles found in oil filters.**

- **CAUSE:**
- Parts of hydraulic circuit are deteriorating.
- **REMEDY:**
- Find deteriorating parts (usually it is the hydraulic pump) and replace. Also replace the oil filter cartridge.



**Premessa**

L'operatore è responsabile nell'ambito del cantiere per tutto quanto riguarda l'impiego del braccio distributore. E' inoltre responsabile della sicurezza della macchina durante l'uso; egli deve continuamente controllare lo stato del braccio ed essere consapevole delle conseguenze che potrebbe avere una errata manovra od un controllo superficiale. Nessun dispositivo relativo alla sicurezza e alla protezione da incidenti deve essere modificato o eliminato. Anche se esiste il solo sospetto di un probabile guasto, occorre effettuare un immediato controllo; e se necessario avvisare il responsabile alla sorveglianza o, in caso di guasti che potrebbero pregiudicare la sicurezza sospendere il lavoro.

**Rischi**

**IN CASO DI IMPIEGO IMPROPRIO SI PUO' INCORRERE NEI SEGUENTI INCIDENTI:**

**Preface**

The operator is responsible for the on-site safety of all aspects of distributor boom operation.  
The operator is also responsible for machine safety during use.  
The condition of the boom must be regularly checked and the operator should be aware of the consequences of incorrect maneuvers or superficial checks.  
Safety or accident protection devices must not be tampered with or removed.  
Even if there is only a suspicion of a fault, an immediate check must be made; notify the person responsible for site safety if necessary or, in the event of a fault which could endanger safety, stop work immediately.

**Risks**

**IN CASE OF IMPROPER USE, THE FOLLOWING ACCIDENTS COULD OCCUR:**

<b>RISCHIO</b>	<i>indice di rischio</i> →	↓	← <i>risk index</i>	<b>RISK</b>
<ul style="list-style-type: none"> <li>Incidenti agli occhi o altre parti del corpo colpiti da olio idraulico durante l'apertura dei raccordi senza prima aver scaricato la pressione nell'impianto.</li> </ul>		<b>M3</b>		<ul style="list-style-type: none"> <li>Injuries to eyes or other parts of body in contact with hydraulic fluid during opening of unions without first have released pressure in the system.</li> </ul>
<ul style="list-style-type: none"> <li>Ferimenti all'addetto al terminale quando quest'ultimo si impiglia nella cassaforma e viene liberato improvvisamente.</li> </ul>		<b>M2</b>		<ul style="list-style-type: none"> <li>Injuries to the operator of the end hose when this becomes tangled in the form and then suddenly freed.</li> </ul>
<ul style="list-style-type: none"> <li>Danni agli occhi causati da spritzbeton, silicato o altri additivi chimici.</li> </ul>		<b>M1</b>		<ul style="list-style-type: none"> <li>Eye lesions cause by spritzbeton, silicate or other chemical additives.</li> </ul>
<ul style="list-style-type: none"> <li>Incidenti causati da movimenti improvvisi degli stabilizzatori girevoli e telescopici, quando il sistema idraulico non era stato adeguatamente svuotato dell'aria oppure quando la macchina viene installata su un terreno in pendenza.</li> </ul>		<b>S4</b>		<ul style="list-style-type: none"> <li>Accidents caused by sudden movements of the rotating and telescopic stabilizers, due to the hydraulic system not having been adequately emptied of air when the machine was installed on sloping ground.</li> </ul>
<ul style="list-style-type: none"> <li>Incidenti causati dallo scoppio di parti della struttura adibiti a deposito di olio o carburante, per effetto di saldature.</li> </ul>		<b>S4</b>		<ul style="list-style-type: none"> <li>Accidents caused by the explosion of parts of the structure that house oil or fuel, as a result of welding operations.</li> </ul>



**SEZIONE D**  
**rischi**

**SECTION D**  
**risks**

<ul style="list-style-type: none"><li>• Incidenti causati da errate manovre, a causa della mancanza delle relative targhette di istruzione.</li></ul>	<b>S4</b>	<ul style="list-style-type: none"><li>• Accidents caused by incorrect maneuvers as a result of the lack of the relative instruction plates.</li></ul>
<ul style="list-style-type: none"><li>• Incidenti dovuti alla caduta del braccio se si lavora con vento di tempesta.</li></ul>	<b>S4</b>	<ul style="list-style-type: none"><li>• Accidents caused by the boom falling when operating in gale force winds.</li></ul>
<ul style="list-style-type: none"><li>• Incidenti causati dalla partenza della macchina a causa del liberarsi dei freni o degli stabilizzatori.</li></ul>	<b>S4</b>	<ul style="list-style-type: none"><li>• Accidents caused by the machine moving due to release of brakes and stabilizers.</li></ul>
<ul style="list-style-type: none"><li>• Danni agli apparati elettrici se non viene disinserito il contatto dal quadro elettrico togliendo la chiave, ogni fine sessione di lavoro.</li></ul>	<b>S4</b>	<ul style="list-style-type: none"><li>• Damage caused by short circuits due to not having taken the key out of the control panel at the end of each work session.</li></ul>
<ul style="list-style-type: none"><li>• Rischio di incidenti per rovesciamento della macchina dovuto al cedimento del piano di appoggio degli stabilizzatori.</li></ul>	<b>S3</b>	<ul style="list-style-type: none"><li>• Accident risk due to machine overturning as a result of stabilizer support surface subsidence.</li></ul>
<ul style="list-style-type: none"><li>• Ferimenti ai lavoratori a causa di un azionamento improprio del telecomando e da quei movimenti vietati ed improvvisi del braccio.</li></ul>	<b>S3</b>	<ul style="list-style-type: none"><li>• Injury to personnel as a result of incorrect handset operation or prohibited and sudden boom movements.</li></ul>
<ul style="list-style-type: none"><li>• Ferimenti alla testa ed al busto dei lavoratori provocati dalla caduta di calcestruzzo dal terminale quando viene spostato in alto sul cantiere, anche a pompa spenta.</li></ul>	<b>S2</b>	<ul style="list-style-type: none"><li>• Injury to head and shoulders of personnel, as a result of concrete dropping from the end hose when raised above the site, even with the pump switched off.</li></ul>
<ul style="list-style-type: none"><li>• Ferimenti causati dallo scivolare su parti oliate o ingrassate della pompa per calcestruzzo.</li></ul>	<b>S2</b>	<ul style="list-style-type: none"><li>• Injuries caused by slipping on oiled or greasy parts of the concrete pump.</li></ul>
<ul style="list-style-type: none"><li>• Danni dovuti all'impatto con il calcestruzzo fuoriuscito per l'apertura dei giunti o tubazioni scoppiate o con gli intasamenti fuoriusciti dalle tubazioni di mandata, o dal terminale flessibile.</li></ul>	<b>S1</b>	<ul style="list-style-type: none"><li>• Injuries caused by contact with concrete discharged from the opening of joints or burst pipes or blockages exiting from delivery pipes, or from the end hose.</li></ul>
<ul style="list-style-type: none"><li>• Danni causati dall'apertura delle tubazioni per calcestruzzo sottoposte a pressioni (in caso di intasamento).</li></ul>	<b>S1</b>	<ul style="list-style-type: none"><li>• Damage caused by opening of the concrete pipes when under pressure (in case of blockage).</li></ul>
<ul style="list-style-type: none"><li>• Incidenti causati dalla caduta di elementi del braccio quando essi vengono movimentati a valvole di blocco aperte senza aver assicurato l'elemento stesso contro una sua eventuale caduta.</li></ul>	<b>C4</b>	<ul style="list-style-type: none"><li>• Accidents caused by the fall of boom sections when these are moved with the lock valves open without having fastened the section to prevent it falling.</li></ul>

**SEZIONE D**  
**rischi**

**SECTION D**  
**risks**



<ul style="list-style-type: none"><li>• Incidenti dovuti all'incastamento mentre gli stabilizzatori girevoli o telescopici stanno estraendo o rientrando nella propria sede.</li></ul>	<b>C4</b>	<ul style="list-style-type: none"><li>• Accidents due to remaining trapped while the revolving or telescopic stabilizers are exiting from or returning into their housing.</li></ul>
<ul style="list-style-type: none"><li>• Incidenti durante marcia su strada dell'autoveicolo per la apertura degli stabilizzatori se non assicurati con fermo meccanico o per l'incompleta chiusura del braccio.</li></ul>	<b>C4</b>	<ul style="list-style-type: none"><li>• Accidents occurring while driving the vehicle on roads due to opening of stabilizers not secured with mechanical clamp or incomplete closing of boom.</li></ul>
<ul style="list-style-type: none"><li>• Incidenti causati dalla caduta di tubazioni non bene assicurate alla struttura del braccio o del tubo terminale se non assicurato con cavo in acciaio.</li></ul>	<b>C3</b>	<ul style="list-style-type: none"><li>• Injuries caused by the fall of pipes not firmly fastened to the boom structure or end hose if the latter is not fastened with a steel cable.</li></ul>
<ul style="list-style-type: none"><li>• Incidenti dovuti al cattivo funzionamento del braccio, per la mancanza di controlli periodici eseguiti da un esperto e annotati sul libro di ispezione.</li></ul>	<b>C3</b>	<ul style="list-style-type: none"><li>• Accidents due to faulty boom operation, due to lack of periodical checks by an expert and noted in the inspection book</li></ul>
<ul style="list-style-type: none"><li>• Scosse elettriche o folgorazioni (pericolo di morte) su macchine con motore elettrico, se l'allacciamento è stato eseguito in modo non corretto o se il cavo d'alimentazione è rovinato.</li></ul>	<b>C1</b>	<ul style="list-style-type: none"><li>• Electric shocks (high danger risk) on machines with electric motor, if connections have been made incorrectly or if the power cable is worn.</li></ul>
<ul style="list-style-type: none"><li>• Folgorazioni dovute al contatto con linee elettriche aeree durante i movimenti o le oscillazioni del braccio.</li></ul>	<b>C1</b>	<ul style="list-style-type: none"><li>• Electric shocks caused in the event of contact with overhead power lines, during the movements of the boom.</li></ul>



## Indice di valutazione del rischio

L'indice di valutazione del rischio delle presenti norme serve per determinare la gravità dei pericoli e la frequenza della loro insorgenza. La lettera indica la gravità mentre il numero indica la frequenza.

### ESEMPIO:

Nella fase di apertura e chiusura degli stabilizzatori, c'è la probabilità di inserimento del personale all'interno del raggio d'azione.

*Il pericolo* viene giudicato catastrofico (C) perché sono possibili gravi ferimenti al corpo per schiacciamento.

*La frequenza* viene indicata con il numero (4) perché il pericolo di insorgenza è improbabile in quanto l'operatore, avendo visione del campo operativo, in presenza di persone interrompe l'azione.

GRAVITA' DEL PERICOLO	
C - catastrofico	Può provocare la morte oppure la distruzione della macchina.
S - grave	Può provocare ferimenti o malattie professionali gravi oppure grossi disturbi alla macchina.
M - medio	Può provocare ferimenti o malattie professionali non gravi oppure leggeri disturbi alla macchina.
N - irrilevante	Non provoca ferimenti o malattie professionali né disturbi alla macchina.

FREQUENZA DELL'INSORGENZA DEL PERICOLO	
1	Molto frequente, una o più volte al giorno.
2	Irregolare, può insorgere settimanalmente, ma non quotidianamente.
3	Insorgenza occasionale, intervalli di tempo non prevedibili.
4	Pericolo di insorgenza improbabile.

## Risk assessment index

The purpose of the risk assessment index of these regulations is to determine the seriousness of dangers and the frequency with which they occur.

### EXAMPLE:

During stabilizer opening and closing operations, there is a possibility of personnel entering the machine range of operation.

*The danger* is qualified as critical (C), because serious injury may be caused as a result of crushing.

*The frequency* is indicated with a number (4), because it is improbable that this danger will arise as the operator has full vision of the field of operation and, in the presence of personnel, will interrupt operations.

SERIOUSNESS OF DANGER	
C - catastrophic	Can cause death or destruction of machine.
S - serious	Can provoke serious injuries or professional illnesses or serious problems to the machine.
M - medium	Can provoke minor injuries or professional illnesses or slight problems to the machine.
N - irrelevant	Does not provoke injuries or professional illnesses nor problems to the machine.

FREQUENCY OF DANGER OCCURRENCE	
1	Very frequent, once or more per day.
2	Irregular, can occur weekly, but not daily.
3	Occurs occasionally at intervals not easily foreseeable.
4	Improbable occurrence.

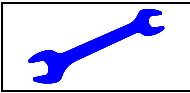

### Verifica pesi sugli assi

La verifica consiste nel controllare che le reazioni **Ra** e **Rb** sugli assi, dovute ai vari pesi gravanti sull'autoveicolo, siano inferiori ai carichi massimi ammessi sugli assi stessi. Tali valori sono riportati sulla carta di circolazione che accompagna ogni veicolo omologato.

### Checking weight on axles

Check that pressures **Ra** and **Rb** on the axles, due to the various weights bearing on the vehicle, are below maximum loads permitted for such axles. These values are indicated on the road circulation document accompanying each homologated vehicle.

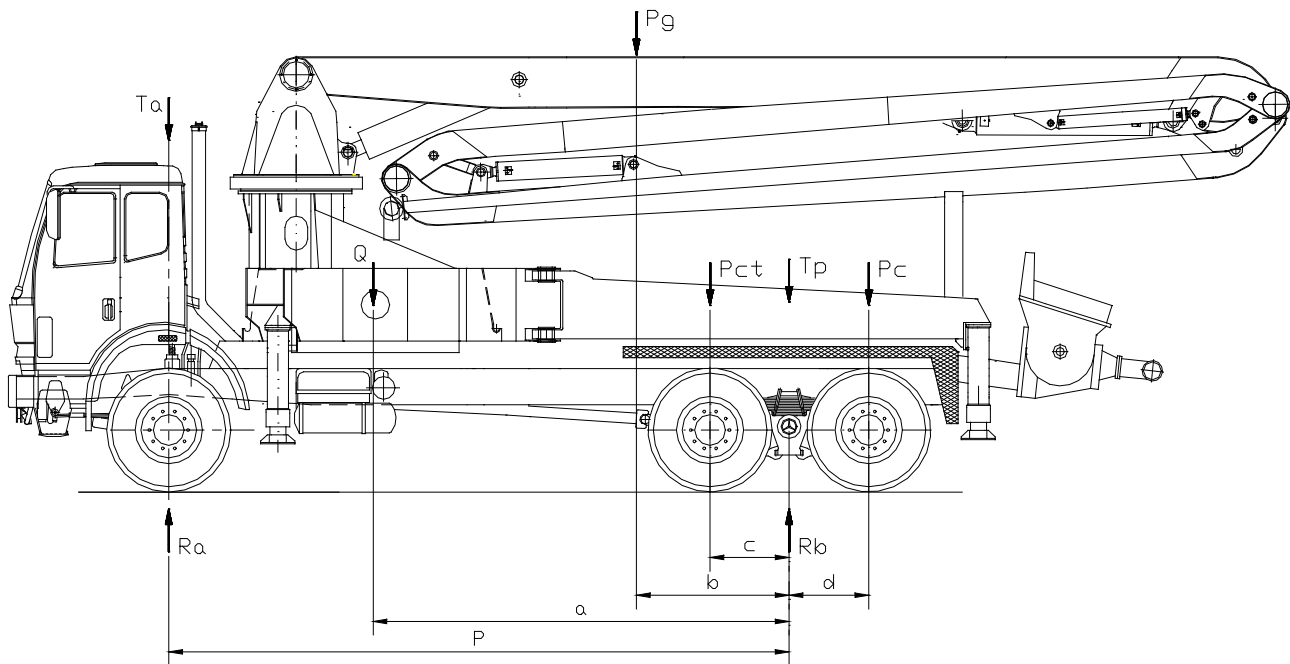

- Ta** = Tara del cabinato sull'asse anteriore
- Tp** = Tara del cabinato sull'asse, o tandem posteriore
- Pg** = Peso del braccio compresi castello e stabilizzatori anteriori e posteriori
- Pc** = Peso pompa calcestruzzo
- Pct** = Peso controtelaio
- Q** = Peso serbatoi acqua e olio per pompa
- Ra** = Reazione sull'asse anteriore
- Rb** = Reazione sull'asse posteriore

- Ta** = Tare weight of cab on front axle
- Tp** = Tare weight of cab on the rear axle or tandem
- Pg** = Weight of boom including turret and front and rear stabilizers
- Pc** = Weight of concrete pump
- Pct** = Counterframe weight
- Q** = Pump water tank and fluid sump
- Ra** = Pressure on front axle
- Rb** = Pressure on rear axle

$$Ra = Ta + [ Q \cdot a + Pg \cdot b + Pct \cdot c - Pc \cdot d ] / P = \dots\dots\dots \text{ daN}$$

$$Rb = Ta + Q + Pg + Pct + Pc - Ra = \dots\dots\dots \text{ daN}$$

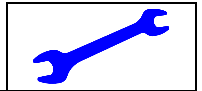

Per alleggerire il carico sull'asse anteriore si possono adottare le seguenti soluzioni:

- a) Arretrare il castello verso l'asse Tp.
- b) Arretrare la posizione della pompa, aumentando il valore della distanza "d".
- c) Adottare un veicolo con passo "P" più lungo.

Per appesantire il carico sull'asse anteriore, si eseguiranno le operazioni inverse.

In order to decrease the load on the front axle, proceed as follows:

- a) Move the turret back towards axle Tp.
- b) Move the position of the pump. (increase distance "d").
- c) Use a motor-vehicle with longer wheel base "P".

In order to increase the load on the front axle, carry out the operations in reverse.

## Verifica di stabilità

In questa parte si descrive il procedimento per verificare la stabilità dell'allestimento (impossibilità della macchina di ribaltarsi). Il metodo qui descritto è quello previsto dalle norme *DIN 15019*.

Esso consiste nel verificare che il momento stabilizzante  $M_s$  sia superiore al momento ribaltante  $M_r$ .

$$M_s > M_r$$

This consists of checking that the righting moment  $M_s$  is greater than the overturning moment  $M_r$ .

L'esperienza insegna che per ottenere risultati conformi ai test di carico, deve essere:  $M_s \geq 1,25 M_r$ .

$$M_s \geq 1,25 M_r$$

Experience has shown that in order to obtain results in line with practical load tests, this must be:  $M_s \geq 1,25 M_r$ .

La verifica di stabilità va eseguita con il braccio perpendicolare alla linea di ribaltamento sia laterale che anteriore, sopra cabina.

The stability test must be carried out with the boom perpendicular to both the lateral and above-cab overturn line.

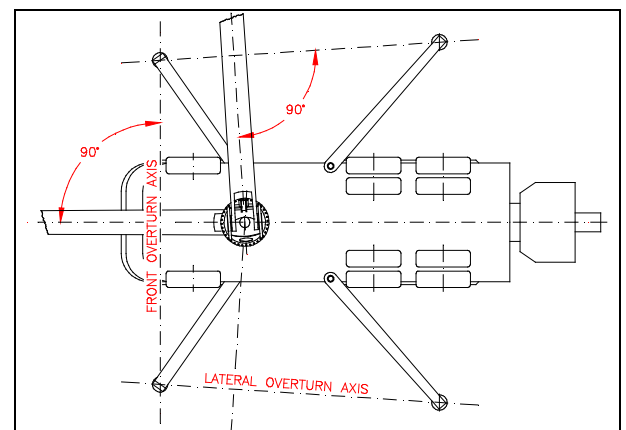
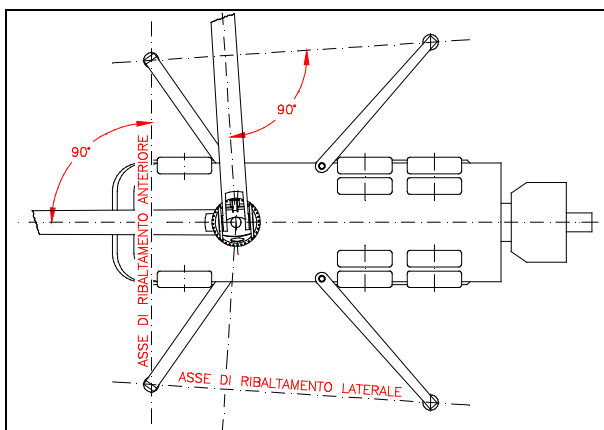

L'asse di ribaltamento è la retta congiungente i due centri dei montanti verticali degli stabilizzatori anteriori e posteriori.

The overturn axis is the straight line joining the two centres of the front and rear stabilizer vertical uprights.



## **Dimensionamento del controtelaio a norme CUNA NC034-05**

Ogni modello di braccio, durante la fase di lavoro, esercita sul telaio dell'autocarro un momento flettente dinamico  $M_d$ . Esso è calcolato rispetto all'asse di rotazione della ralla ed è dato dalla somma del momento dovuto al peso proprio del braccio e del momento dovuto al peso del calcestruzzo nella tubazione. Per simulare l'effetto dinamico, si moltiplicano questi carichi per dei coefficienti, in funzione della velocità di movimentazione. L'andamento del momento flettente dinamico è di tipo lineare, massimo in corrispondenza della mezzeria della superficie di fissaggio del braccio e nullo in corrispondenza del punto di appoggio opposto all'estremità posteriore del basamento.

## **Sizing of the counterframe in accordance with CUNA NC034-05 standards**

During operation, each boom model exercises a dynamic flexure moment  $M_d$  on the vehicle chassis. This is calculated with respect to the swivel axis of the thrust ring and is given by the sum of the moment due to the weight of the boom itself and of the moment due to the concrete in the pipeline. To simulate a dynamic effect, these loads are multiplied by coefficients, function of the speed of movement. The dynamic flexure moment follows a linear pattern which achieves maximum height at the centre line of the boom fastening surface and zero at the opposite rest point, at the rear end of the base.

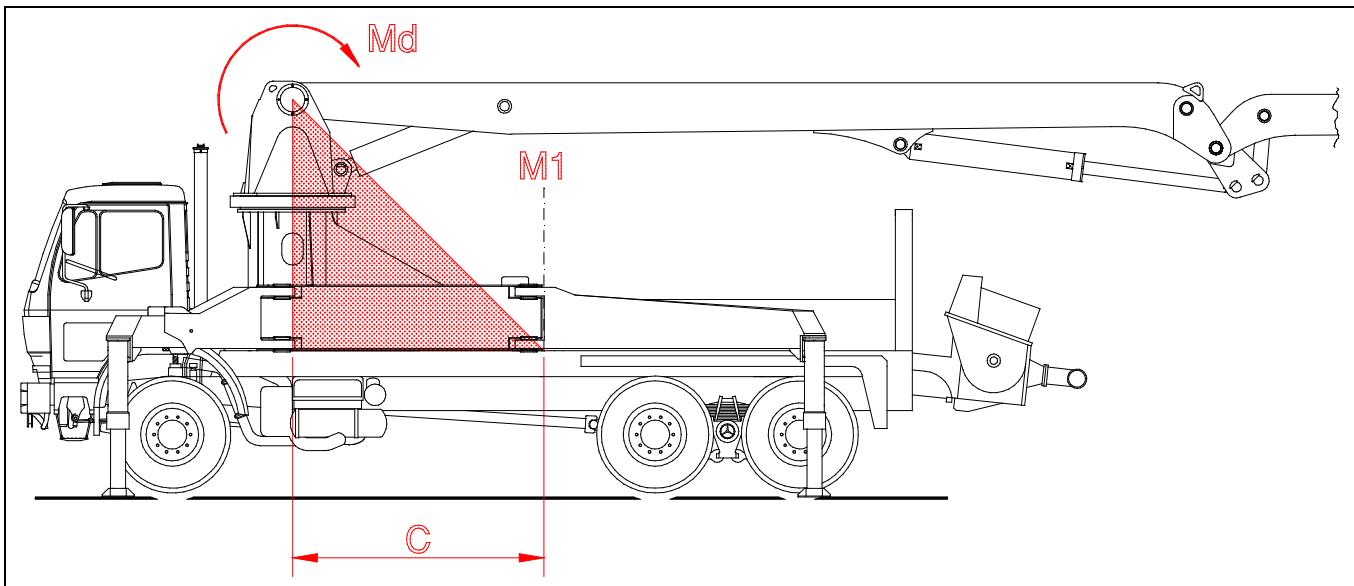

### **Verifica preliminare**

Si considera il controtelaio, sia durante la fase operativa che durante la fase di marcia, sollecitato a flessione e taglio. La sollecitazione ammissibile  $\sigma_t$  del telaio viene definita per l'Italia, dalle norme UNI; essa è comunque funzione del limite allo snervamento e della resistenza a rottura del materiale. Qui di seguito, in tabella, diamo alcuni esempi riguardanti i materiali più usati

### **Preliminary check**

During both the operation and transport stages, the counterframe is subjected to flexure and shearing. Permissible chassis stress  $\sigma_t$  is set in Italy by UNI standards. This is, in any event, a function of yield and breakage resistance points of the material. Hereunder is a table showing some examples of most used materials



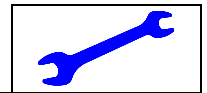

(ricavati dalle UNI-CNR10011).

(taken from UNI-CNR 10011).

TIPO DI MATERIALE	Fe 360.2	Fe 430.2	fe 510.3	St 690	TYPE OF MATERIAL
LIMITE ALLO SNERVAMENTO	> 235	> 275	> 355	> 690	YIELD POINT
RESISTENZA A ROTTURA	> 360	> 430	> 510	> 730	BREAKAGE RESISTANCE
SOLLECITAZIONE AMMISSIBILE $\sigma_t$	160	190	240	390	PERMISSIBLE STRESS $\sigma_t$

I valori sono dati in N/mm<sup>2</sup>. Questi valori valgono chiaramente anche per la sollecitazione ammissibile  $\sigma_c$  del controtelaio.

Values are given in N/mm<sup>2</sup>. These values are clearly also valid for permissible stress  $\sigma_c$  of the counterframe.

### Calcolo del controtelaio

Per il calcolo si fa riferimento alle norme della scienza delle costruzioni.

### Calculation of the counterframe

For this calculation, reference is made to construction science standards.

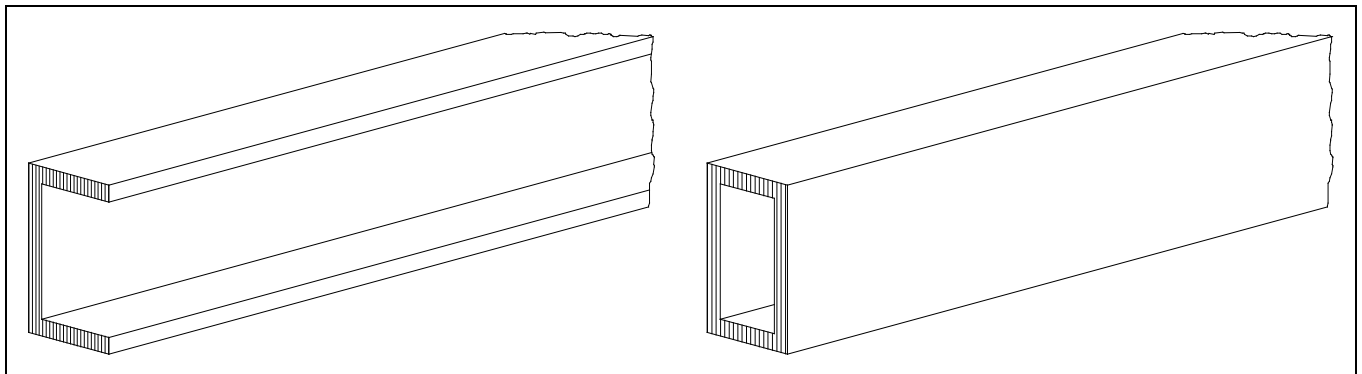

Nella zona sottostante il basamento del braccio si deve far in modo che il controtelaio resista anche allo schiacciamento derivante dal peso del basamento, per cui si consiglia di applicare sempre sezioni scatolate. Ove necessario si deve irrigidire in questa zona anche la sezione del telaio.

In the area below the boom bed, steps must be taken to ensure the counterframe also resists pressure from the weight of the bed. We consequently recommend always fitting box sections. Whenever necessary, the chassis section must also be strengthened in this area.

### Realizzazione del controtelaio

Il controtelaio si deve estendere fino all'estremità dell'autotelaio. La sezione resistente necessaria del controtelaio deve risultare costante per una lunghezza non inferiore a due volte la lunghezza di appoggio del basamento del braccio. I due longheroni del controtelaio, vanno collegati fra di loro tramite delle traverse perpendicolari ai longheroni stessi, oppure posti in diagonale a formare una crociera. In tal modo si aumenta la rigidità torsionale della struttura.

### Making the counterframe

The counterframe must extend to the end of the vehicle chassis. The resistant section of the counterframe must be consistent for a length of not less than twice the support length of the boom bed. The two main members of the counter-frame must be connected together by two cross-pieces, or arranged diagonally crossways. In this way, the torsion strength of the structure is increased.



## SEZIONE G norme d'installazione

## SECTION G installation instructions

Diventa indispensabile l'applicazione delle strebe nel caso di allestimento con barra stabilizzatrice posteriore trasversale. Per evitare una brusca variazione di sezione, il controtelaio deve terminare con uno smusso come raffigurato negli esempi.

In the event of setup with rear stabilizer crossbar, the fitting of stiffening bars becomes indispensable. To prevent sudden cross-section variations, the counterframe must terminate with a chamfered edge as shown in lower figures.

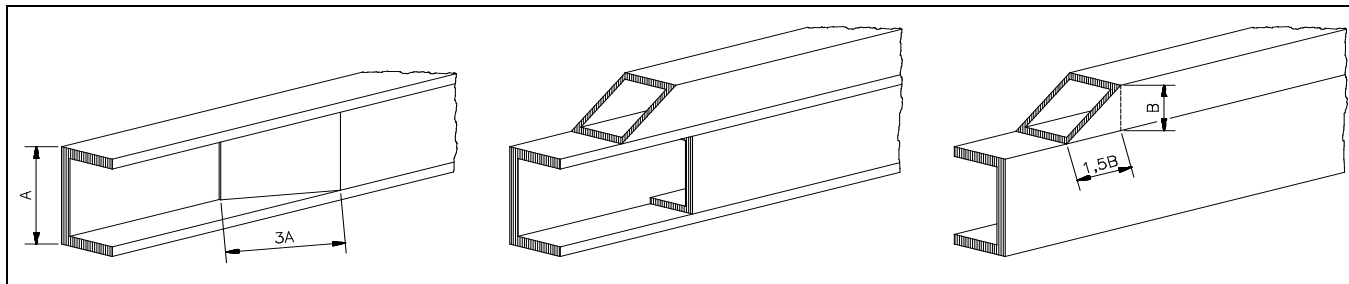

La barra stabilizzatrice posteriore deve essere inserita nel controtelaio ed essere ad essa solidale.

The rear stabilizer bar must be inserted in the counterframe and be an integral part of it.

### Fissaggio del controtelaio

Nel fissare il controtelaio al telaio si devono utilizzare innanzitutto i punti di attacco previsti sul telaio stesso.

Il controtelaio deve essere a diretto contatto con il telaio del veicolo realizzando il più possibile una continuità di appoggio. Le distanze disuguali tra gli angolari di fissaggio del telaio e del controtelaio oppure eventuali sporgenze sul telaio, si compensano interponendo degli spessori di acciaio. Se i punti di fissaggio sul telaio non sono sufficienti oppure non sono utilizzabili, si devono prevedere ulteriori fissaggi in altri punti adatti.

Il gioco tra foro e vite deve essere al massimo di 0,3 mm. Si devono utilizzare viti parzialmente filettate, di classe 10.9. Il filetto delle viti non deve toccare la parete del foro. La distanza massima tra una piastra di fissaggio e quella successiva non deve essere superiore a un metro.

### Attaching the counterframe

When attaching the counterframe to the chassis the attachment points on the chassis should be used.

The counterframe should be directly in contact with the vehicle chassis, providing a continuous support base. The unequal distance between the attaching corners on the chassis and the counterframe or any eventual overhang on the chassis, will be compensated by inserting steel shims. If the attaching points on the chassis are insufficient or cannot be used, other attaching points in suitable positions must be used, e.g.

The play between the hole and the screw should be 0.3 mm max. Partially threaded screws (10.9) should be used. The screw thread should not touch the sides of the hole. The maximum distance between attachment plates should not exceed one meter.

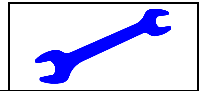

## Fissaggio del basamento

L'incastellatura viene appoggiata sul contro-telaio e saldata allo stesso per mezzo di quattro appendici in lamiera, già integrate nella struttura del castello. La giunzione saldata deve essere eseguita con procedimento MAG, filo pieno della classe SG3, cordone ad angolo con i seguenti parametri:

**150A - 24V - 14.000J**

Vi ricordiamo che l'operazione di serraggio delle viti va eseguita con la coppia di serraggio ricavabile dalla seguente tabella:

## Attaching the base

The support frame is placed on the counterframe and welded in position by means of four sheet metal plates, already provided on the turret structure. The welding joints must be carried out with the MAG method, using class SG3 full wire, corner bead with the following parameters:

**150A - 24V - 14.000J**

The screw tightening operation should be performed with the torque wrench setting shown on the following table:

DIAMETRO DELLA VITE		M10x1.5	M12x1.75	M14x2	M16x2	SCREW DIAMETER	
COPPIA DI SERRAGGIO daNm	VITE CLASSE 8.8	5.1	8.5	13.5	20.5	SCREW CLASS 8.8	TORQUE WRENCH SETTING daNm
	VITE CLASSE 10.9	7.1	11.9	19	28	SCREW CLASS 10.9	

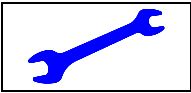

## **Scelta della pompa oleodinamica e applicazione**

Il braccio descritto nel presente manuale viene messo in funzione da una pompa oleodinamica a pistoni assiali, solitamente collegata al cambio dell'autoveicolo per mezzo di relativa presa di forza. I dati fondamentali per la scelta della pompa sono la portata dell'olio Q (l/1') necessaria al distributore proporzionale e la pressione massima P (daN/cm<sup>2</sup>) di esercizio dell'impianto. Questi valori si leggono, per ogni modello, nella relativa scheda tecnica e rappresentano valori medi. Sono possibili scostamenti pari al 2% sui valori delle pressioni e 10% sui valori delle portate. E' importante verificare che il senso di rotazione della pompa (sinistrorso e destrorso) sia identico a quello della presa di forza.

Il braccio deve funzionare per il tempo strettamente necessario per la distribuzione del calcestruzzo; per tale motivo la presa di forza è corredata di un comando di innesto. Questo dispositivo di comando può essere di tipo pneumatico, meccanico o elettrico, e viene posto, ove possibile, nella cabina dell'autoveicolo. Per gli azionamenti di tipo pneumatico o elettrico si fa uso della energia fornita dagli apparati dell'autoveicolo.

La pompa può essere applicata direttamente alla presa di forza oppure tramite un albero cardanico. Nel secondo caso la pompa dovrà essere fissata al controtelaio con un supporto rigido. I tre assi dell'albero cardanico non possono avere angoli di deviazione tra loro, maggiori di quelli indicati dai costruttori degli alberi stessi. I tubi flessibili di aspirazione e mandata della pompa non devono fare curve strette e devono avere dimensioni proporzionate alla portata (consultare il catalogo costruttori pompe).

Ogni volta che si concludono le operazioni di distribuzione del calcestruzzo e prima di mettere in movimento l'autoveicolo, si deve disinserire la presa di forza; questo per evitare di procurare danni meccanici irreparabili alla pompa oleodinamica. Si consiglia quindi di installare sul cruscotto dell'automezzo una

## **Hydraulic pump selection and application**

The boom described in this manual is operated by means of a hydraulic pump with axial pistons, normally connected to the vehicle transmission by means of a power takeoff. The fundamental data for the selection of the pump are the oil flow rate Q (l/1') necessary for the proportional distributor and the system maximum operating pressure P (daN/cm<sup>2</sup>). These values can be found, for each model, in the relative technical card and they represent average values. Deviations of 2% are possible with pressure values and 10% with flow rates. Check that the sense of rotation of the pump (left or right-handed) is identical to that of the power takeoff.

The boom should operate for the amount of time strictly necessary for the distribution of the concrete; for this reason the power takeoff is supplied with a clutch control. This control mechanism can be pneumatic, mechanical or electric and should be fitted, where possible, in the driver's cab on the vehicle. For pneumatic or electrical operations energy can be taken from the equipment on the vehicle.

The pump can be directly applied on the power takeoff or with the use of a cardan shaft. In the event of the use of the cardan shaft the pump should be attached to the counterframe by means of a rigid support. The three axes of the cardan shaft must not display angles of deviation that are greater than those indicated by the shaft manufacturers. The flexible suction and delivery hoses should not present tight curves and should be dimensioned in proportion to the flow rate (consult the pump manufacturers catalogue).

Each time concrete distribution operations are concluded, and before moving the vehicle, the power takeoff must be disconnected; this is to avoid irreparable mechanical damage to the hydraulic pump. It is advised to fit a pilot lamp and/or acoustic warning on the vehicle instrument panel, which will indicate

## SEZIONE G

### norme d'installazione

spia luminosa e/o acustica che avverta del mancato disinserimento della presa di forza.

La pompa viene collegata al serbatoio dell'olio per l'aspirazione, e al distributore oleodinamico per la mandata. Può essere inserito un filtro oleodinamico per alta pressione sulla tubazione di mandata, oppure un filtro in aspirazione sul serbatoio o sullo scarico. Controllare sempre che detti filtri siano provvisti di indicatori di intasamento. Prima di innestare la pompa oleodinamica, assicurarsi che le saracinesche, che chiudono i condotti di aspirazione, siano completamente aperte. Il serbatoio dell'olio deve essere in posizione sopraelevata rispetto alla pompa.

#### **Istruzioni per il montaggio dei flessibili**

I tubi flessibili che collegano il distributore con il braccio, devono essere liberati da tensioni torsionali.

Procedimento per eseguire tale operazione: dopo aver collegato i tubi dell'impianto oleodinamico, girare il braccio di 180°, portandolo chiuso a pacco sopra la cabina, allentare i raccordi che collegano i tubi flessibili al primo elemento del braccio, e liberarli da eventuali tensioni dovute a torsione. Serrare nuovamente i raccordi seguendo le modalità descritte nella *sezione C* del manuale.

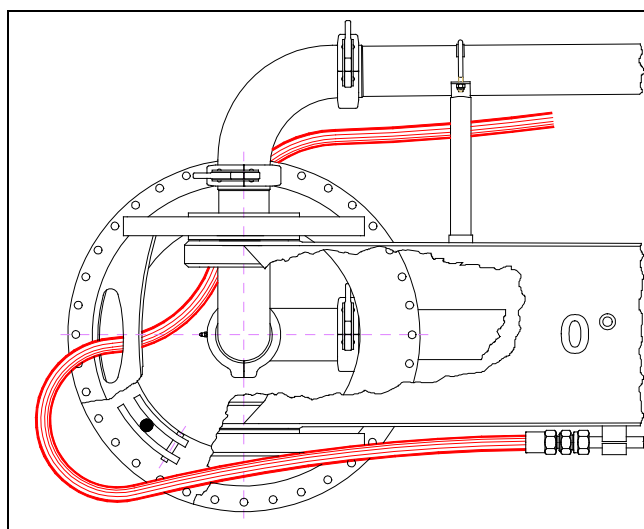

I tubi flessibili che collegano il distributore con il braccio devono essere disposti come indicato nello schema, per evitare che vengano sottoposti a trazione.

## SECTION G

### installation instructions

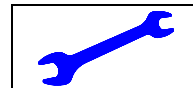

when the power takeoff has not been disconnected.

The pump is connected to the oil tank for suction and to the hydraulic distributor for delivery.

A high pressure hydraulic filter can be fitted on the delivery piping, or a suction filter on the tank or discharge.

Make sure that these filters are provided with clogging indicators.

Before engaging the hydraulic pump, make sure that the gate valves, that close the suction intake pipes, are completely open.

The oil tank must be positioned on a higher level than the pump.

#### **Instructions for assembling flexible hoses**

The flexible hoses that connect the distributor to the boom must be free from torsional stress.

This operation should be carried out as follows: after having connected the hydraulic system hoses, rotate the boom through 180°, moving it to the close position above the cab, loosen the unions that connect the flexible hoses to the first element of the boom and release any eventual stress that may have been caused by torsion. Tighten the unions, following the procedure described in *section C* of the manual.

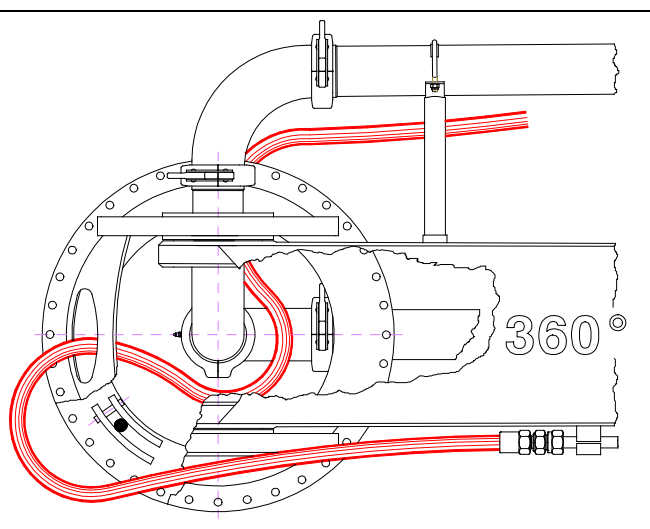

The flexible pipes which connect the distributor with the boom are to be arranged according to the diagram, to prevent them from being subjected to tensile stress.



**Tabella delle pressioni**

**Table of pressures**

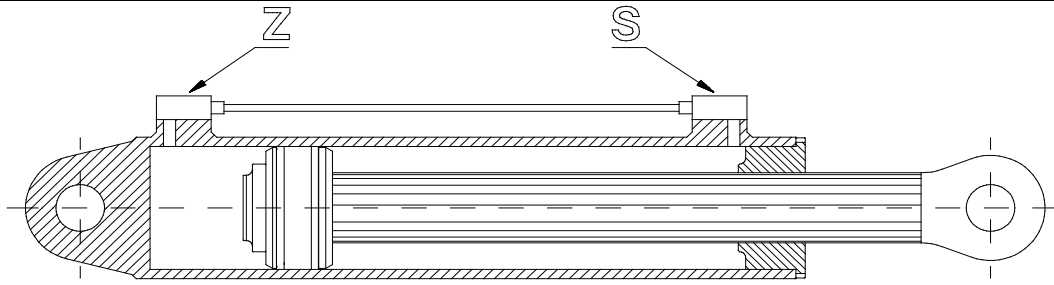

MANOVRE	Z		S		pressione pressure (bar)	MANOEUVRE
	pressione pressure (bar)	strozz. thrott.	pressione pressure (bar)	strozz. thrott.		
1° Elemento braccio	250	-	250	-	-	1° Boom element
2° Elemento braccio	250	-	250	-	-	2° Boom element
3° Elemento braccio	250	-	320	-	-	3° Boom element
4° Elemento braccio	200	-	320	Ø1	-	4° Boom element
Rotazione	-	-	-	-	140	Rotation
Traslazione stabiliz.	100	-	200	-	-	Traverse stabilizers
Stabilizzatori girevoli	100	-	200	-	-	Swinging stabilizers
Verticali	100	-	200	-	-	Vertical
Valvola distributore	-	-	-	-	320	Distributor valve

**Tabella dei tempi di manovra**

**Table of manoeuvre times**

Tempi in secondi ± 10%

Time in seconds ± 10%

MANOVRE		TEMPI - TIMES	MANOEUVRE	
POMPA OLEODINAMICA	tipo lt/1'	50	type lt/1'	HYDRAULIC PUMP
CILINDRO 1°ELEMENTO BRACCIO	esce entra	140 115	out in	CYLINDER 1°BOOM ELEMENT
CILINDRO 2°ELEMENTO BRACCIO	esce entra	140 120	out in	CYLINDER 2°BOOM ELEMENT
CILINDRO 3°ELEMENTO BRACCIO	esce entra	80 75	out in	CYLINDER 3°BOOM ELEMENT
CILINDRO 4°ELEMENTO BRACCIO	esce entra	70 70	out in	CYLINDER 4°BOOM ELEMENT
ROTAZIONE	1 giro	185	1 rev.	ROTATION
APERTURA ANTERIORI	apre chiude	18 18	open close	SWINGING FRONT STABILIZERS
SFILAMENTO ANTERIORI	esce entra	8 8	out in	OPENING FRONT STABILIZERS
APERTURA POSTERIORI	apre chiude	8 8	open close	SWINGING REAR STABILIZERS
STABILIZZATORI VERTICALI ANT. e POST.	sfilata salita	25 31	down up	VERTICAL STABILIZERS FRONT AND REAR

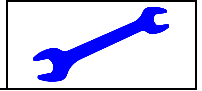

## **Dispositivo di segnalazione di “braccio chiuso”**

Quando il braccio è chiuso e appoggiato sul cavalletto, in ordine di marcia, attiva un interruttore applicato all'estremità del cavalletto stesso.

Applicare l'interruttore alla base del piano di appoggio del braccio, in prossimità del tampone di gomma. Inclinare lo stesso in modo che, con il braccio appoggiato sul cavalletto, l'antenna dell'interruttore si pieghi nella posizione in cui si verifica la chiusura del circuito elettrico attivando la spia verde.

Completare l'installazione applicando il pannello delle spie rossa e verde sulla plancia strumentazione nella cabina dell'autoveicolo. Collegare i cavi in modo che venga attivata la spia rossa STOP quando il braccio non è correttamente chiuso, e la spia verde START quando la posizione corretta assicura il consenso alla marcia.

## **“Boom closed” indication mechanism**

When the boom is closed and resting on the stand, in the transport position, the microswitch fitted at the end of the stand is activated.

Apply the switch at the base of the boom rest support, near the rubber buffer. Tilt the microswitch so that when the boom is resting on the stand, the antenna is pressed, closing the electric circuit and thereby illuminating the green pilot light.

Complete the installation by fitting the red and green pilot light panel on the instrument panel in the driver's cab. Connect the wires so that the red STOP light is illuminated when the boom is not correctly closed, and the green START light illuminates when the correct position assures the consensus to start.



## SEZIONE G norme d'installazione

## SECTION G installation instructions

### Posizionamento delle targhe di segnalazione e istruzione

Applicare le targhette e gli adesivi sulla macchina come illustrato nelle seguenti figure.

### Positioning the signal and instructions plate

Apply the plate and the decals on the machine as shown in the following drawings.

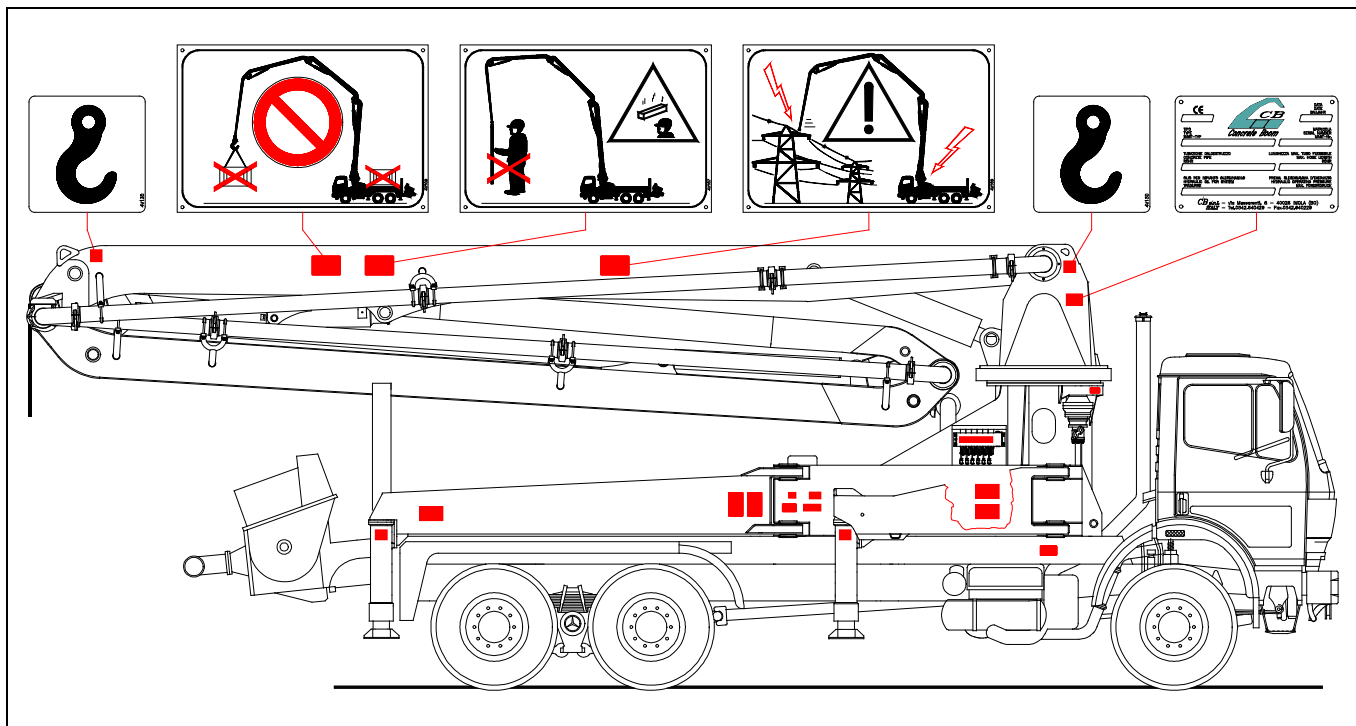
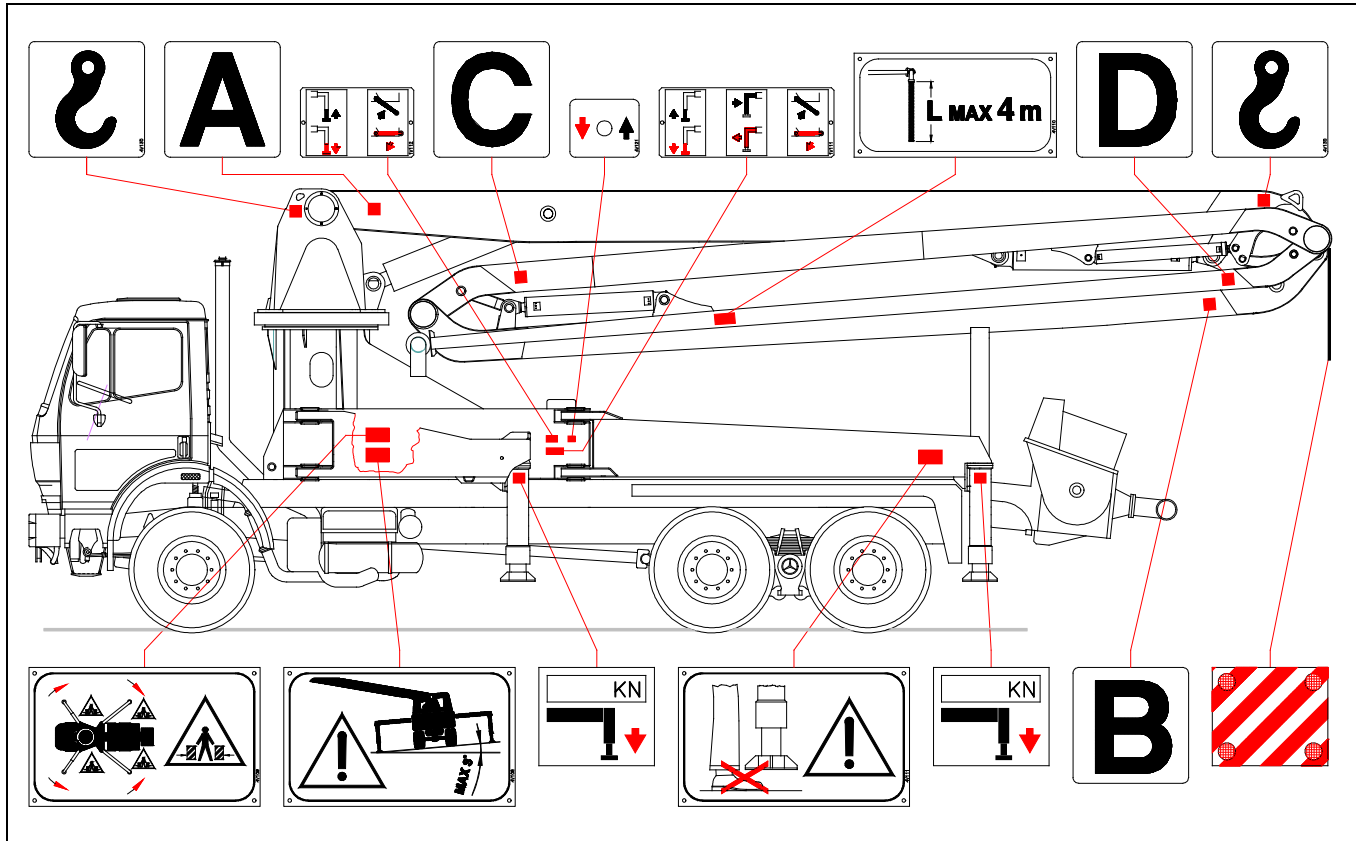



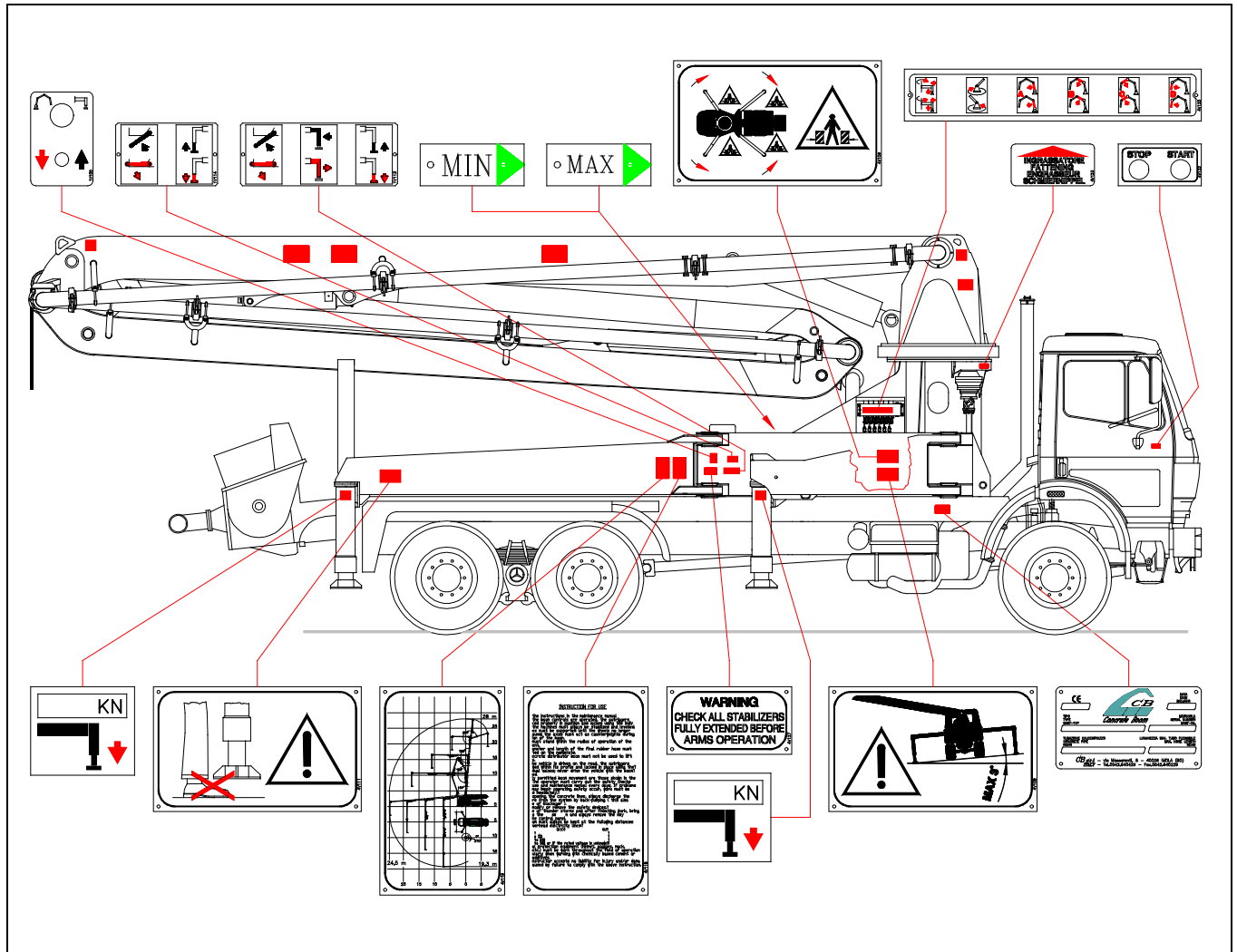
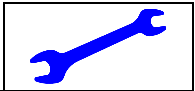

### Targa di identificazione

A completamento dell'installazione della macchina sull'autoveicolo è necessario applicare la targhetta in dotazione, (*sotto*), punzonando i dati relativi al telaio dell'autoveicolo. Normalmente la targhetta viene applicata sul lato anteriore destro del controtelaio.

### Identification plate

Once the machine has been installed on the vehicle, the plate supplied will need to be attached (*see below*), stamped with the relative vehicle chassis data. Normally the plate should be fitted on the front right hand side of the counterframe.

		Waitzinger Baumaschinen Vertrieb & Service GmbH Neu-Ulm / Germany			
Modell Model	<input type="text"/>	Zul. Gesamtgewicht (kg) Total weight perm. (kg)	<input type="text"/>		
Maschinen Nr. Masch.-No.	<input type="text"/>	Zul. Achslast (to.) Axle weight perm. (to.)	<input type="text"/>		
Baujahr Year of construction	<input type="text"/>	max. Abstützdruck (kp) max Outriggers press. (kp)	<input type="text"/>		
max. Hydraulikdruck max. Hydr. pressure	<input type="text"/>	max. Betondruck (bar) max. Concrete press. (bar)	<input type="text"/>		
V max. (km/h)	<input type="text"/>	max. Drehzahl max. rpm	<input type="text"/>		
WAI106179					

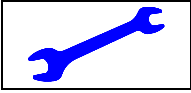

**SEZIONE G**  
*norme d'installazione*

**SECTION G**  
*installation instructions*

---

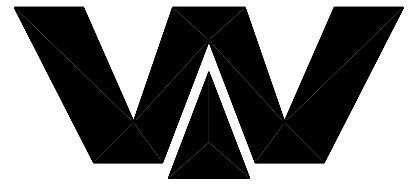

*Waitzinger  
Baumaschinen GmbH*

# *Bedienungsanleitung operation manual*

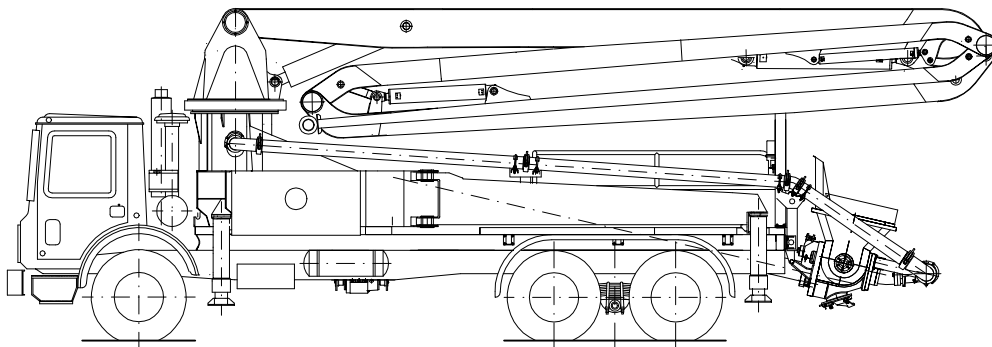

***36 R 4 XT  
Masch.-Nr. 204460***

<b><u>1</u></b>	<b><u>Description</u></b>	<b>4</b>
1.1	<u>Description of main components</u>	4
1.2	<u>Description of pumping cycle</u>	5
<b><u>2</u></b>	<b><u>Safety regulations</u></b>	<b>6</b>
2.1.1	<u>Field of application</u>	6
2.2	<u>Qualifications and duties of the pump operator</u>	7
2.3	<u>Important safety regulations</u>	7
2.3.1	<u>In general</u>	7
2.3.2	<u>Maintenance and repair</u>	9
2.3.3	<u>Working area</u>	10
2.3.4	<u>Placing</u>	10
2.3.5	<u>Minimum wall thickness and operating pressure of conveyor pipes</u>	12
<b><u>3</u></b>	<b><u>Operation of the Concrete Pump</u></b>	<b>13</b>
3.1	<u>In general</u>	13
3.1.1	<u>Description of the operating elements</u>	13
3.1.2	<u>First starting / test run</u>	15
3.1.3	<u>Manual function of control block</u>	15
3.1.4	<u>First starting: drive cylinders</u>	15
3.1.5	<u>Spare function with fault of sensors or amplifier</u>	16
3.2	<u>Set up the concrete pump</u>	16
3.3	<u>Concrete pumping</u>	17
3.3.1	<u>Start pumping</u>	17
3.3.2	<u>Pumping hints (depending on concrete quality)</u>	17
3.3.3	<u>Pumping hints (depending on machine)</u>	18
3.4	<u>Cleaning</u>	19
3.4.1	<u>Cleaning by suction</u>	19
3.4.2	<u>Cleaning with pressure water</u>	20
3.5	<u>Conversion and replacement of wear parts</u>	21
3.5.1	<u>Replacement of wear plate and wear ring</u>	21
3.5.2	<u>Replacement of conveyor pistons</u>	22
3.5.3	<u>Replacement / turning of conveyor cylinders</u>	23
3.5.4	<u>Replacement of the agitator tool</u>	23

<b><u>4</u></b>	<b><u>Maintenance</u></b>	<b>24</b>
<b><u>4.1</u></b>	<b><u>General hints</u></b>	<b>24</b>
<b><u>4.2</u></b>	<b><u>Daily maintenance</u></b>	<b>24</b>
<b><u>4.3</u></b>	<b><u>After the first 50 operating hours</u></b>	<b>24</b>
<b><u>4.4</u></b>	<b><u>Weekly maintenance</u></b>	<b>24</b>
<b><u>4.5</u></b>	<b><u>Every 100 operating hours</u></b>	<b>24</b>
<b><u>4.6</u></b>	<b><u>Every 500 operating hours</u></b>	<b>25</b>
<b><u>4.7</u></b>	<b><u>Every 1000 operating hours</u></b>	<b>25</b>
<b><u>4.8</u></b>	<b><u>Tightening torque's for screws</u></b>	<b>25</b>
<b><u>4.9</u></b>	<b><u>Lubrication</u></b>	<b>26</b>
<b><u>4.10</u></b>	<b><u>Lubricants</u></b>	<b>27</b>
<b><u>5</u></b>	<b><u>Trouble Shooting</u></b>	<b>29</b>
<b><u>5.1</u></b>	<b><u>Truck engine does not start</u></b>	<b>29</b>
<b><u>5.2</u></b>	<b><u>Pump unit does not start (without hydraulic pressure)</u></b>	<b>29</b>
<b><u>5.3</u></b>	<b><u>Pump unit stops (at maximum pressure)</u></b>	<b>29</b>
<b><u>5.4</u></b>	<b><u>Pump unit works with too low performance</u></b>	<b>29</b>
<b><u>5.5</u></b>	<b><u>Agitator does not work</u></b>	<b>30</b>
<b><u>5.6</u></b>	<b><u>Hydraulic oil is getting too hot</u></b>	<b>30</b>
<b><u>5.7</u></b>	<b><u>Faulty operations</u></b>	<b>31</b>
<b><u>5.7.1</u></b>	<b><u>Drive cylinders work with shortened stroke</u></b>	<b>31</b>
<b><u>5.7.2</u></b>	<b><u>Faulty operation of tilting cylinders</u></b>	<b>31</b>
<b><u>5.7.3</u></b>	<b><u>Delayed switch over with pressure peaks</u></b>	<b>31</b>
<b><u>5.7.4</u></b>	<b><u>Changing of stroke number is too fast / too slow</u></b>	<b>32</b>
<b><u>5.8</u></b>	<b><u>Grease system does not work</u></b>	<b>32</b>
<b><u>5.8.1</u></b>	<b><u>Mixing wing does rotate</u></b>	<b>32</b>
<b><u>5.8.2</u></b>	<b><u>Mixing wing does not rotate</u></b>	<b>32</b>

## **PREFACE**

Before operating this machine please read carefully the following instructions.

We have tried to keep this instruction manual as short as possible in order to help you in becoming quickly acquainted with our machines. We are, however, obliged by law to include complete details on the technical construction, maintenance and safety regulations, etc. So that we are unable to shorten this manual further. This is for your own safety, also for persons concerned with this machine.

The pump operator and all persons concerned with this machine are equally obliged to study this manual thoroughly, not only to operate it properly and economically, but also to avoid damage and accidents.

We must draw your attention to the fact that our warranty is void if your machine is not operated and maintained according to our instructions. If you have any queries or problems contact the technical advisers at our company. We would be pleased to help you and would enjoy hearing from you.

Spare parts and wear parts, or any other parts which are not supplied by the manufacturer or his authorised representative are excluded from the warranty. For foreign products no responsibility can be taken.

Claims cannot be made on the manufacturer as a result of any information contained in or omitted from this manual, especially with regard to the construction and/or the assembly of the machine.

Due to our continued efforts to improve our machines in every way, modifications are effected from time to time and it could be that some changes could not be included in this manual at the time of going to print.

Please take into consideration that the present operation manual is valid for different versions of this pump model. Therefore it is possible that the pump version ordered by you may be different to the technical version described in this manual.

Accessories and all spare parts are listed in a special catalogue / spare part list according to the part numbers. For spare part orders please indicate the part number, the model and the machine number.

This manual should be regarded as an essential part of the THP-Trailer-Pump of the Waitzinger Baumaschinen GmbH company. It should be kept in a safe place as a reference book.

## 1 Description

### 1.1 Description of main components

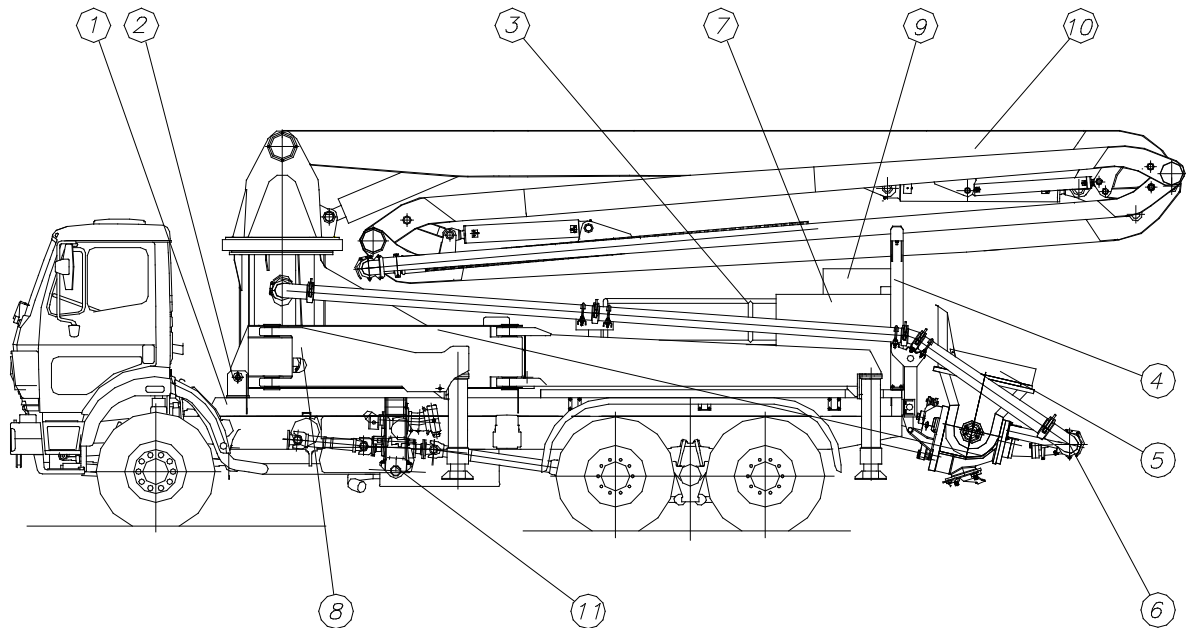

- |    |  |
|----|--|
| 1  | Subframe                                   |
| 2  | Frame connection for boom base             |
| 3  | Pedestal, reling and ladder                |
| 4  | Boom support                               |
| 5  | Pump unit with main control block          |
| 6  | Concrete delivery pipeline                 |
| 7  | Additional water tank with water pump      |
| 8  | Boom base with outrigger                   |
| 9  | Control panel                              |
| 10 | Distributor boom                           |
| 11 | Distribution gear box with hydraulik pumps |

# Description

## 1.2 Description of pumping cycle

1. electric motor. The control system is electric and fully automatic. When using the monitoring switch a spare function can be switched on additionally which enables a continuous working of the concrete pump at reduced engine speed upon breakdown of the control system or the sensors. The number of strokes can be adjusted from minimum to maximum. The drive cylinders (1) have an automatic leakage compensation. The S-tube valve compensates the wear on the wear plate and on the wear ring automatically.

1:	Drive cylinder, right	6:	S-valve
2:	Control block	7:	Wear plate
3:	Water box	8:	Tilting drive
4:	Conveyor piston	9:	Conveyor
5:	S-valve system with agitator	10:	Drive cylinder, left

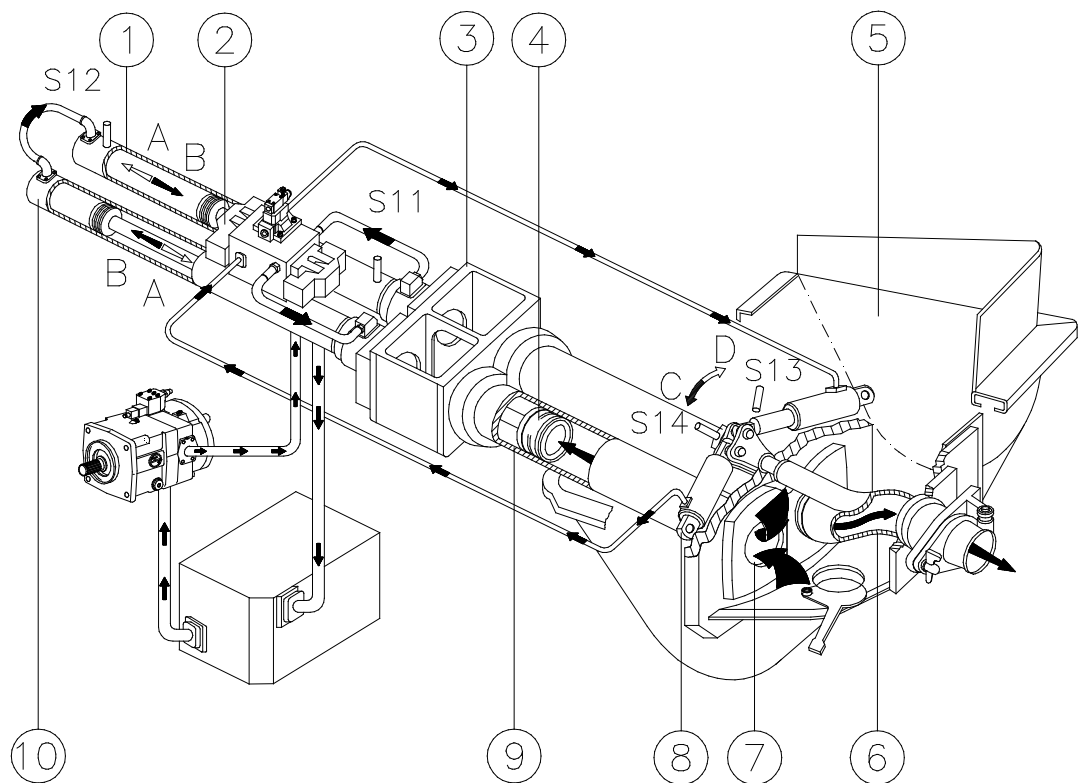

The concrete pump works as follows: The tilting cylinders are in pos. S13. During the pumping the pressure relief valve Y3 is closed electrically while Y4b is being started. The drive cylinders run into direction "A". The concrete in the left conveyor cylinder is pressed through the S-tube valve into the conveying line. In the right conveyor cylinder concrete is sucked from the open bore hole in the hopper. As soon as sensor S12 is switched on, Y4b stops while Y5b is being started. The drive cylinders stop and the tilting cylinders move into position "C".

The S-valve is now at the front of the right conveyor cylinder. Sensor S14 starts Y4a (Y5b stops) and the drive cylinders move into position "B". The right conveyor piston pumps the concrete through the S-valve while the left one sucks the concrete out of the S-valve housing. Sensor S11 stops Y4a and Y5a shifts the S-valve back into position "D". Thus the cycle is being finished.



## 2 Safety regulations

### 2.1.1 Field of application

#### The use of this pump can be dangerous!!

1. The current operating instructions must be in the vehicle.
2. Operator must be trained and must sign confirming that he has "taken note" of the operating instructions.
3. The operator is obliged to behave in accordance with the operating instructions. The works Guarantee is cancelled if your machine is not operated and maintained in accordance with the operating instructions.
4. The following injuries can occur in improper use:
  5. Injury to the eyes due to sprayed concrete, water glass or other chemicals.
  6. Injury to eyes and other parts by hydraulic oil shooting out when joints are opened without first relieving the accumulator pressure.
  7. Injury due to the force of bursting couplings, bursting pipes or blockages shooting out.
  8. Danger from contact with live electrical wires.
  9. Electric shock (possibly resulting in death) due to touching machines with an electrical drive, if the electrical connection was not correctly made or the supply cable is damaged.
  10. Danger of tipping over due to the supports sinking.
  11. Injury due to swivel and telescopic support legs moving out quickly if not properly "bled".
  12. Injury due to parts of pipeline falling down due to screwed joints or couplings gradually coming undone.
  13. Injury of workers due to unintentional operation of the boom controls and therefore unintentional movement of the boom.
  14. Injuries to head and shoulders due to concrete dropping out of the end hose if the placing boom is moved above the site at a great height (also with the pump switched off).
  15. Injury due to boom arms falling down if valve blocks are opened without first ensuring that the corresponding boom arm has been secured.
  16. Injury of someone at the hose end from the end hose if it has caught in the reinforcement and suddenly moves out when the boom continues to move.
  17. The pump rolling away due to the brakes or the support legs coming off.
  18. Injury due to opening delivery pipes which are under pressure (after blockages).
  19. Injuries due to reaching into or falling into the agitator or the pressure devices.
  20. Injuries due to slipping on the oily or greasy machine.
  21. Injuries due to reaching into the waterbox with the piston moving.
  22. Injuries due to stumbling over cables, hoses, reinforcing material.
  23. Injuries due to being jammed in by the truck mixer or its parts (chute).
  24. Injuries due to slipping or falling from the unsecured delivery lines.

# Safety regulations

## 2.2 Qualifications and duties of the pump operator

Pumps and/or placing booms may be operated and maintained only by persons (operator, machine driver) who

1. are aged 18 years and older,
2. are both physically and mentally capable
3. have been trained to operate and maintain the pump and/or the placing boom and have shown proof of these capabilities to the contractor
4. are not under influence of alcohol , drugs ,and medicine

Safety devices may not be altered resp. removed and are to be used in a correct manner.

Before setting the machine into operation, check the operational reliability . In the case of faults and defects, or even just a hint of same, steps must be taken immediately to remedy them and the person in charge informed, if necessary. Work should be discontinued at the smallest hint of danger.

If accidents are caused due to negligence or non-observance of safety regulations laid down by the respective unions and Factory Inspectors, the operating personnel will be made liable. If they cannot be made responsible, due to lack of training or knowledge, the person in charge of the operating personnel will be made liable. Please make sure, therefore, that great care is taken at all times.

## 2.3 Important safety regulations

### 2.3.1 In general

1. Work with pumps and placing booms is subject to the specific regulations of the country resp. the responsible employers

- liability association and the operating and maintenance regulations of the manufacturer.
2. The concrete pumps may only be used as intended by their manufacturer and as described in his instruction manual. Regulations call for the availability of such an instruction manual at the construction site.
3. All devices for safety and prevention of accidents such as informative and warning notices, cover grids, metal guards, must be available. They must not be removed or altered.

### DANGER OF ACCIDENTS!

During operation of the machine, it is not allowed to remove any protective devices (e.g. water box covering) or to set any safety installations (e.g. limit switch or mechanical safety device for switching off the grid) out of operation.

4. The concrete pumps together with their delivery lines have to be inspected when necessary according to the operational conditions and working situations, but at least once a year, by a qualified person. The results of the testing have to be written down in the enclosed check book and have to be shown on request. This inspection is prescribed by law.

Check wear on the concrete delivery line daily by knocking, or better by using a wall thickness measuring device and replace worn out parts in time, resp. as a precaution. For min. wall thickness see under "min. wall thickness and operating pressure of conveyor lines".

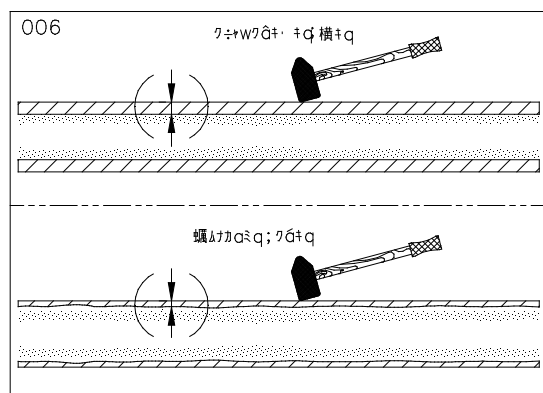

## ATTENTION:

If worn out resp. defective parts (high pressure hoses) are not replaced immediately, the manufacturer will not take over any warranty.

## DANGER OF ACCIDENTS!

Never knock or open the line under pressure.  
Always pump 1 - 2 strokes in reverse first.

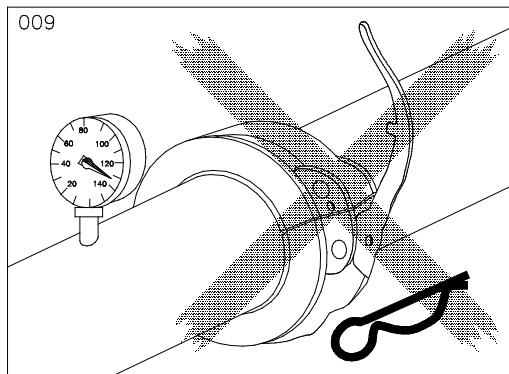

6. When concrete pressure above 85 bar (vertical and horizontal pumping) the following safety measures must be taken and checks made or supervised by the pump operator.
  - Use exclusively piping of the concrete pump manufacturer. With concrete pressures between 85 bar and 130 bar high pressure piping and more than 130 bar special piping is required.
  - Carry out water pressure test for pipes and couplings latest after pumping 2000 m<sup>3</sup>. Test pressure 30% higher than the expected maximum operating pressure.
  - Change couplings, seals and pipe elbows regularly (e.g. every 1000 m<sup>3</sup>) near to which operating personnel may approach at a distance of less than 3 m.

Do never grab inside the hopper, to the s-valve or inside the water box during the engine is running. First you have to stop the engine and release the system pressure. Take care of the sign of danger at the hopper. Secure the opened grid against unintentional closing.

## ATTENTION DANGER OF LIFE!

It is not allowed to modify the hydraulic accumulator circuit. It is strictly forbidden to remove leads of safety valves or to modify the hydraulic pipe system.

7. If the cable control is connected with the socket i.e. if the connection cable from the remote control to the machine does not present any defect, the cable control can only be laid down if the 'emergency-shutdown button' has been actuated. For 're-setting into operation' (after having cleared fault) release the emergency-shutdown-button by turning in direction of arrow.
8. You have to disconnect the cable control during pumping breaks and repair work, in order to avoid unintentional operating.
9. Use ascents and handles if you step up to the machine.
10. Control and testing installations have to be kept free of dirt, oil, snow and ice.
11. In order to avoid concrete spraying by air being sucked in, the agitator hopper has always to be filled with concrete up to the mixer shaft.
12. Cleaning of the conveyor pipes by compressed air is not allowed. Waitzinger Baumaschinen Vertrieb und Service GmbH does not take any liability for accidents.
13. The maximum conveying pressure must not be higher than indicated at the data plate.
14. First aid
  - a) Keep all information available concerning the treatment of work specific accidents.
  - b) Any injuries must be reported to a supervisor or a responsible deputy supervisor.

# Safety regulations

## 2.3.2 Maintenance and repair

Carry out maintenance work regularly.

### ATTENTION:

Throttles and pressure limiting valves, may only be modified by skilled staff. It is forbidden to remove seals of safety valves.

1. Modification-, welding- and repair on the placing boom and all assembly groups belonging to it, supporting members, fixture, support legs, mounting frame and each part of the pump or parts under pressure may only be performed by persons nominated by the manufacturer.

### 'DANGER OF EXPLOSION!'

These works must be inspected by an expert with regard to their execution according to the specific regulations for concrete pumps and concrete placing booms ZF 1/573 issued by the Inspector of Factories, resp. the social insurance association for occupational accidents or the legislator of your country.

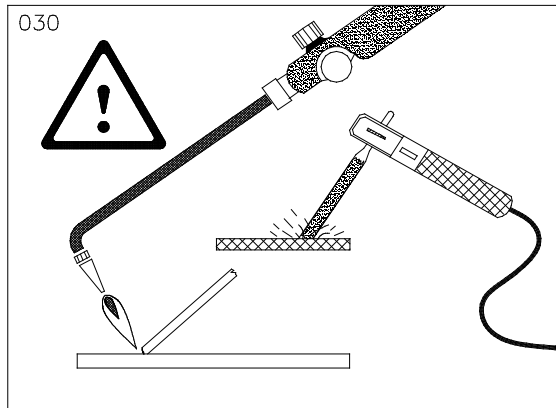

### ATTENTION:

Before carrying out electric welding, plug out cable harness from the control box and disconnect battery. In order to disconnect the battery both plus and minus have to be detached.

2. The drive engine must always be shut down and pressure let off the hydraulic units and lines before carrying out repairs or maintenance work. Release the pressure in the accumulator. Remove the key of the engine!
3. Works on machines equipped with hydraulic accumulators (repair, maintenance) may only be carried out after the pressure in the liquid has been released. It is not allowed to modify the hydraulic accumulator circuit. Never allow non-experts to perform a repair. Test certificates delivered with accumulators must be kept in a safe place.
4. If components of electric, pneumatics or hydraulics are replaced (valves, pumps etc.) they have to be checked according to the data (pressure, voltage etc.) of the machine card, data sheet or circuit diagram and adjusted accordingly.
5. In order to get a longer life time of conveyor pipes, you should turn straight pipes for 120° clockwise and conveyor bows for 180° anti clockwise after pumping about 6000m<sup>3</sup>. Take care of minimum wall thickness and operating pressure.

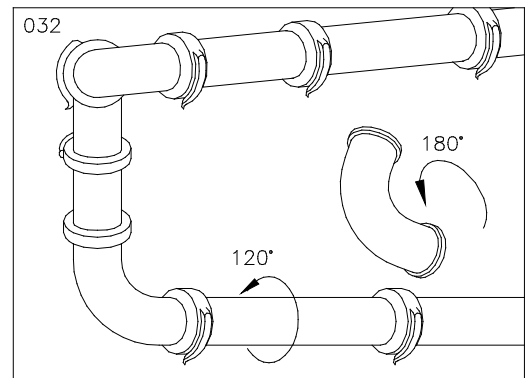

6. When dismantling parts take note of their fitting position. Make use of the spare parts service information to ensure correct assembly!

## 2.3.3 Working area

1. The operator is responsible for the complete working area when using the machine and must have a good view over the hole area. If the operator during pumping operation cannot see the concrete placing hose, a means of communication between the place where concrete is poured and the concrete pump must be established. When leaving the machine, always make sure that it is secured against unauthorised use.
2. Close the working area off from general traffic and public according to regulations in force.

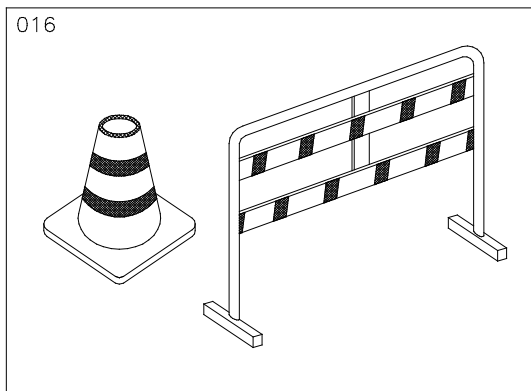

3. A personal protective equipment (helmets, spectacles, mask, gloves etc.) has to be worn in the hole working area if cement or additives for mortar on a chemical base is used for working.

The unauthorised stay in the danger area of the machine is forbidden. Any persons staying there have to be warned; stop working if persons do not leave the danger area in spite of being warned.

## 2.3.4 Placing

### CAUTION!

It is not allowed to start PUMPING with the Trailer Pump before it is set up at the outriggers according the Operation Manual. Also take care of your countries safety regulations.

1. Secure couplings with pin to prevent opening by themselves.

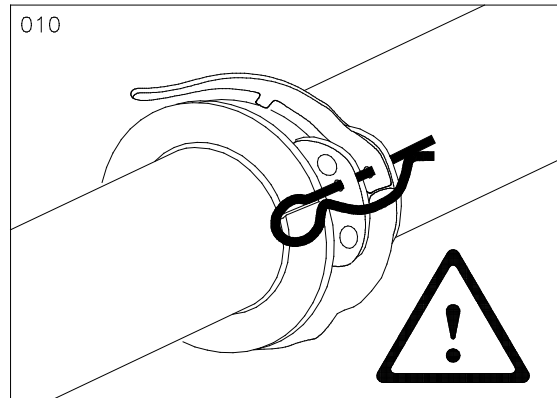

2. Check that the conveyor pipelines and connections are perfectly in order before commencing work.
3. Before start pumping procedure, check delivery lines, couplings and hoses for secure fixture.
4. When the machine stands on sloping ground, block wheels with wedges, let off brake and let vehicle run slowly towards wedges. Afterwards support machine.

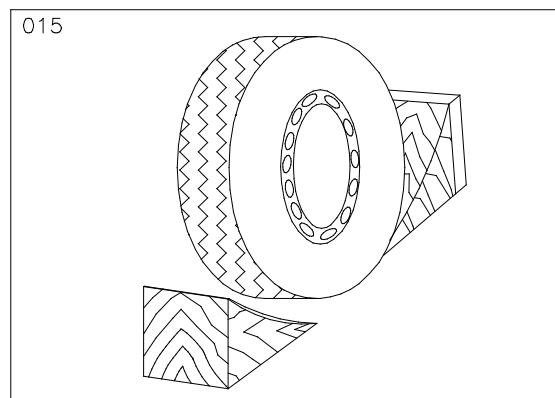

5. You have to keep a safe distance to obstacles, cranes, buildings and other disturbing things.
6. The pump must be set up on firm ground to ensure its stable standing. Keep away from slopes, embankments, pits, trenches and ditches, as these may collapse under the pressure exerted by the support legs.

## Safety regulations

7. The ground must be checked to make sure that it may not negatively affect the stable standing of the machine. If the ground is not firm enough, the supporting area should be increased by using suitable materials laid crosswise in two layers. German standard see DIN 1054.

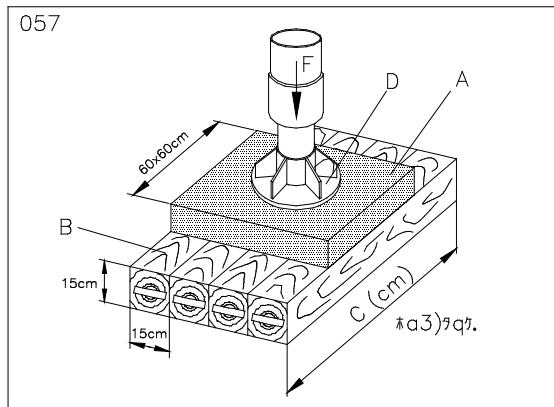

8. The support legs and feet must be locked mechanically or hydraulically in position.

**2.3.5 Minimum wall thickness and operating pressure of conveyor pipes**

Y = concrete pressure in bar  
X = minimum wall thickness in mm according to DIN 2413 T3  
DN = nominal diameter

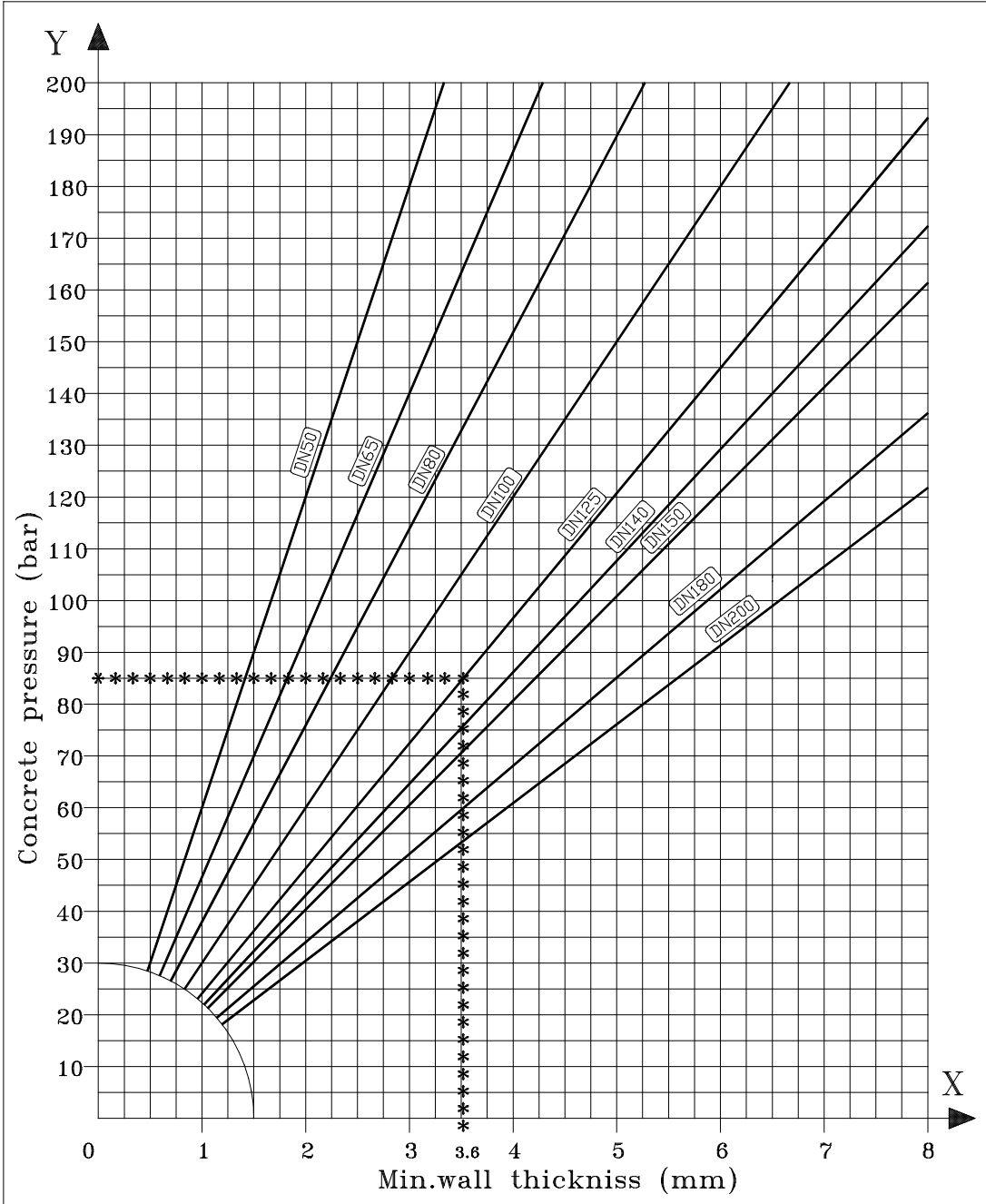

# Operation of the Concrete Pump

## 3 Operation of the Concrete Pump

### 3.1 In general

1. Before the operation the operator has to read the operation manual in order to avoid accidents and damages.
2. The operator is responsible for the safety during any operation of the machine. Therefore he is obliged to take the necessary safety measures on the concrete pump and to inform every worker of the safety hints who is working in the danger zone of the machine. For the additional appliances which are not described in this manual the separate, enclosed operation an maintenance manuals are valid.

### 3.1.1 Description of the operating elements

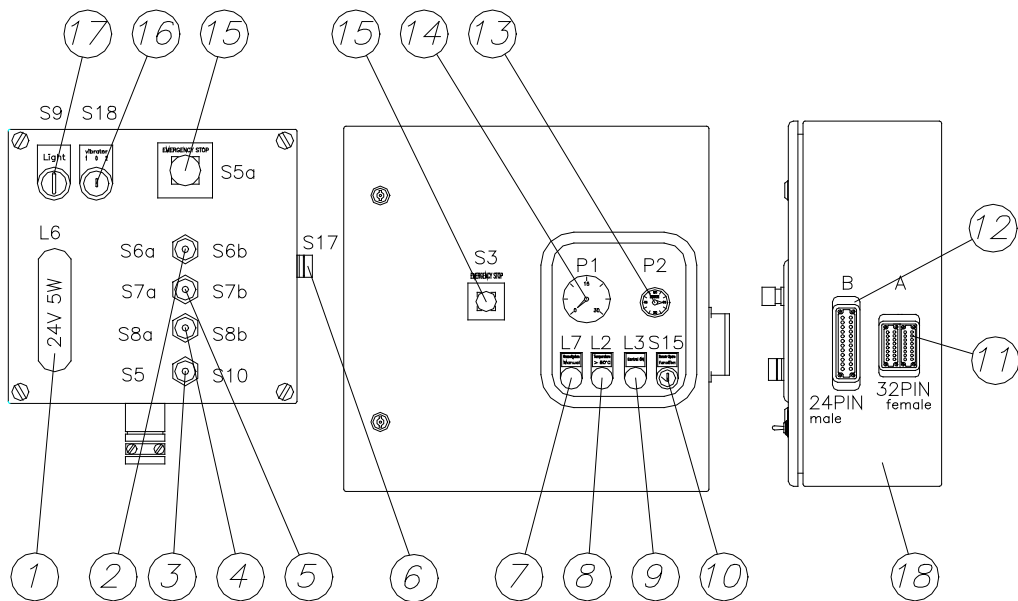



## Operation of the Concrete Pump

1. = Panel light
2. = Select switch - PUMPING / SUCTION this is a 2 position toggle switch used to control the cycle direction of the concrete pump. The „PUMPING“ position will start the pump . The „SUCTION“ position stop the pump and reverse the pump function as long as the switch is operated .
3. = Horn/ Grease pump manual switch .this is a 2 position toggle switch used to interrupt the preset timing cycle of the grease pump.The lubrication cycle is preset and will automatically start and stop as set . If the pumping function is „ON“ by moving the toggle to „GREASE“ position the grease pump will start .The position „HORN“is used to activate the chassis horn for signaling purposes . The horn is also controled by the oil pressure . If the pressure is higher as adjusted on the pressure switch beside the control block the horn is „ON“ to show you the pressure is to high. ( concrete blockage , sensor failed )
4. = Switch for changing stroke + / -  
After pushing in „+“ - position for more than 5 seconds the maximum stroke number is reached.  
After pushing in „-“ - position for more than 5 seconds the minimum stroke number is reached.
5. = Switch for changing r.p.m. + / -  
(function also without running engine).  
Position „+“ increase the engine r.p.m.  
Position „-“ decrease the engine r.p.m.
6. = Engine " START "( only if the truck is prepared for this function .17)
7. = Indication of grease pump.
8. = Indication for oil temperature higher than 80° C  
As soon as the indication lights on "PUMPING" is interrupted. Only suction is possible.
9. Power indicating lamp
- 10.= Select switch for spare functions  
Position 0 = without spare function  
Position A = spare function if amplifier failed  
Position B = spare function if sensor failed
- 11.= Socket for cable harness 24 pin
- 12.= Socket for cable harness 32 pin
- 13.= Counter for operating hours of the pump
- 14.= R.p.m. indication engine
- 15.= Emergency stop and engine stop button ( engine stop only if the truck is prepared for this function)
- 16.= Vibrator Position 1 = manual Position 0 = off Position 2 = auto (only with option vibrator)
- 17.= Panel light switch.

# Operation of the Concrete Pump

## 3.1.2 First starting / test run

1. You have to test the complete machine each time before it is used at the jobsite.
2. Check filling levels (hydraulic oil - engine oil - diesel fuel - cooling water - battery acid - grease in grease pump)
3. Fill the water box with water. It is inadmissible to run the concrete pump without filled up waterbox.
4. Check wear out parts for the wear out limit. Close the grid at the hopper and lock it with the nuts.
5. Check, if the valve for agitator and the switch for PUMPING / SUCTION is in middle position. Unlock emergency stop. Drive the r.p.m. motor out for 1/3 of stroke. Start engine. (switch pos. 16).
6. Warm up the engine with about 1000 r.p.m. Take care of leakings at engine and hydraulic system.
7. Start PUMPING during medium r.p.m. and switch on the grease pump manual. Check agitator in all two directions. The hydraulic pressure for the agitator should be not higher than 40 bar (without load). Lubricate the conveying pistons in end position. Take care of leakings.
8. Check function PUMPING / SUCTION with maximum engine r.p.m. and different stroke numbers. (switch over function / endposition drive cylinder). Check maximum stroke number (see at the data sheet).
9. Check the indications for hydraulic filter element. The indication for the hydraulic filter must be inside the green area, if you run with maximum r.p.m. and maximum stroke number and the oil temperature is higher than 30° C. If the red indication lamp lights up during maximum r.p.m. you have to change the filter element.

## 3.1.3 Manual function of control block

For safety reasons you have to move the drive cylinders or the tilting cylinders manually, if you need a defined position of them. You can move the cylinders if you use an suitable tool for the way valves Y4 and Y5. The valve Y3 is activated by hand.

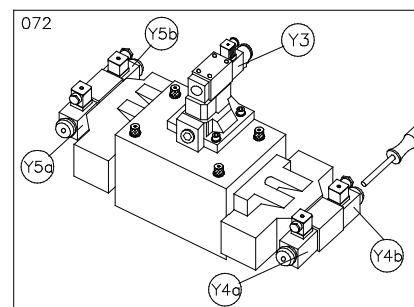

**ATTENTION:** If valve Y3 is activated single, the hydraulic pressure will increase to maximum. Therefore, you have to activate the corresponding valves Y4 or Y5 first. After this you can push and release Y3 for the stroke. Don't release Y3 before you released the way valves. If you work with manual function, you have to run the engine with low r.p.m.

## 3.1.4 First starting: drive cylinders

At the first starting or after change of the drive cylinders:  
(hydraulic connection: rod side)

1. Drive the right hand drive cylinder slowly out by activating valves Y4a and Y3 at the same time.

# Operation of the Concrete Pump

2. Breathe off hydraulic swing space - open the highest plug of the right drive cylinder and activate valves Y4a + Y3 slowly, till the left drive cylinder reaches end position without being springy.
3. Breathe off seals - open the plug of the right drive cylinder and activate Y4b + Y3 as often as oil without air comes out. Repeat this procedure with left drive cylinder (Y4a + Y3).

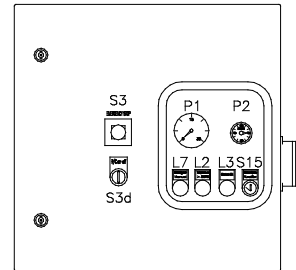

## 3.1.5 Spare function with fault of sensors or amplifier

It is possible to work with the truck concrete pump by spare function, if there is a fault with the sensors or with the amplifier. You can use the spare function in order to finish a already started work. This operating is unfavourable for the hydraulic system. Therefore you should reduce the maximum r.p.m. for about 20%.

1. How to find the fault; during a fault of sensors the hydraulic system stops in end position. The horn signals the maximum pressure because of the assembled pressure switch.
2. Stop PUMPING at once.
3. Change the spare function switch S15 to position "B".
4. Start PUMPING and check if the same fault happens again, or not.
5. If the fault continues, switch spare function to position "A".

## 3.2 Set up the concrete pump

1. Please see the „ Installation manual“ of the concrete distributor boom - Section B .

# Operation of the Concrete Pump

## 3.3 Concrete pumping

### 3.3.1 Start pumping

Directly before start of the pumping, you have to fill some buckets with lubrication mixture (cement, water, sand) into the hopper during running agitator. In order to lubricate the complete conveyor pipes with the mixture, you should pump two sponge balls through the pipeline. Pump slowly until full concrete jet comes out of the end pipe.

### ATTENTION:

Maximum output pressure may not higher than it is indicated at the data plate respectively in the test book.

2. If you use new and long conveyor pipes the friction resistance is higher. Therefore you need enough lubrication mixture.
3. Pump several strokes and switch on the agitator system..
4. The concrete inside the Truck Mixer must be mixed with highest speed. Take care of constant prepared concrete mixture. It must be mixed at least for about 4 minutes, after addition of concrete additives (accelerator, retarder).
5. Fill the concrete out of the Truck Mixer or the tank inside the hopper and start Pumping.

### ATTENTION:

If the conveyor pipes are rusty (high resistance) increase the concrete output steady after several  $m^3$ .

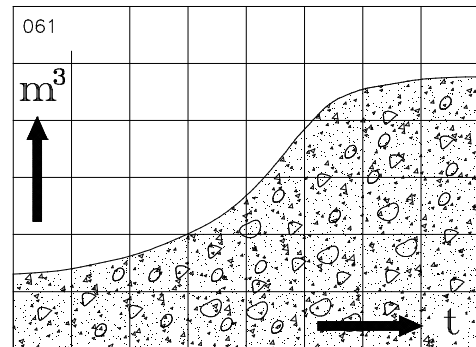

6. At concrete blocking inside the pipeline, you have to suck the concrete back into the hopper and mix it with the agitator. Don't start PUMPING, before s-valve and drive cylinder switch automatically. Start PUMPING very carefully.
7. Reasons for concrete blocking:
  - a) Lubrication mixture contents too much water
  - b) Not enough lubrication mixture used
  - c) Leaky s-valve
  - d) Leaky pipelines
  - e) Old, hardened concrete inside s-valve and conveyor pipes
  - f) unfavourable concrete compound.

### 3.3.2 Pumping hints (depending on concrete quality)

1. During pumping of difficult concrete compounds, the agitator rod should be visible! It is easier to pump unfavourable concrete (extremely stiff and with low sand mixtures; light concrete) at half filled hopper. (under edge of agitator rod). In this case the concrete pump also sucks air inside the conveyor cylinder and PUMPING is easier possible. BUT: Take care of concrete blocking!!!

# Operation of the Concrete Pump

2. During break times of PUMPING you should relieve the conveyor pipes from pressure by sucking 2 or 3 strokes . During the break time you should move the concrete inside the pipeline. Never let the pipeline under pressure.
3. Try to pump the hopper completely empty, during pumping breaks, if you use very liquid concrete with rough corn.
4. During long pumping breaks suck the concrete back to the hopper, mix it, and pump it again.
5. During very long pumping breaks switch off the engine, in order to avoid dismixing of the concrete because of vibrations. Move the concrete by pumping and suction, in time distances from 10 to 15 minutes.

Never try to press already hardened or dismised concrete into the conveyor pipe by force.

6. Avoid breaks, especially for up pumping from concrete, which can't keep the water. Also suck as long as the s-valve tilts to endposition at both sides, before you start PUMPING again with this kind of concrete mixture.
7. It is very dangerous, if air comes inside the pipeline, because the compressed air comes out with a stroke at the end of the conveyor line and catapults the concrete away like explosion. This can happen if the hopper isn't filled enough with concrete or if you lengthen the pipelines.

### 3.3.3 Pumping hints (depending on machine)

1. Do never break the maximum r.p.m. of the diesel engine, because this will damage the hydraulic pump. Admissible r.p.m see at the data sheet.
2. Watch stroke reduction (piston stroke) and compensate if possible.

3. Fill the water box with fresh water, if the oil temperature breaks 80°C during continuous operation with high load.

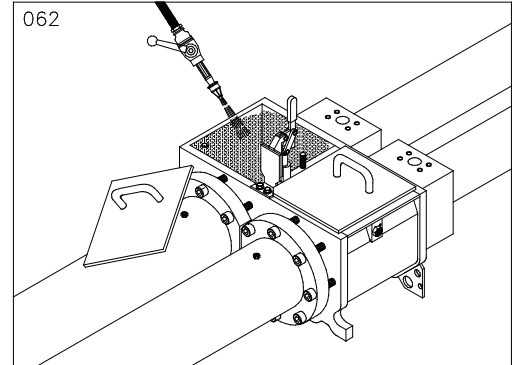

If the temperature increases further, exchange the water continuously. Search for the reason of overheat and eliminate. The thermo static oil cooler starts at temperatures higher than 55°C.

4. Don't sprinkle the hydraulic oil tank with water. This causes damage of hydraulic pump or develops condensing water. If there is no more other possibility, you can spray a jet of water directly to the drive cylinders..

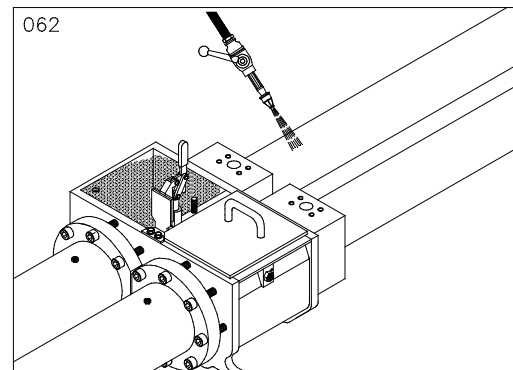

5. All pumps possess a thermo -electrical stop. At oil temperatures higher than 80°C pumping stops automatically and the red indication lamp at the control panel lights up.

### Steps:

- a) Switch off the pump .

# Operation of the Concrete Pump

- b) Don't stop the engine. Oil cooler must go on.
  - c) Renew the water inside the water box.
  - d) Start pumping again, after the indication lamp goes out. Pump only with reduced performance.
  - e) Search for the reason of oil overheating. Eliminate the mistake. - (Look at chapter 5, mistake search)
  - f) The temperature sensor for thermo - electrical switch off is assembled at the hydraulic tank..
6. Don't stop the engine after long running with big performance. Let the engine run with about 1000 r.p.m. in order to cool it. This is very important especially for turbo charged engines.
  7. Adjust the engine r.p.m. so that the engine is running uniform (higher than 700 U/min.).
  8. The producer does not take any liability for any damages happened because of operating mistakes.

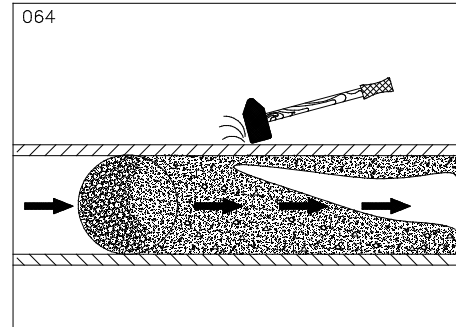

4. Open the conveyor pipe and take out the cleaning sponge.
5. You have to repeat the suction of the sponge ball, if your pipeline is very long. For long distances is one time cleaning not enough..
6. S-valve and agitator will stop, if you open the hopper grid, in case of safety stop, assembled at the grid. Lock the grid during cleaning the pipeline. Don't open the bolts during cleaning, If the hopper grid is assembled with screws.
7. Take out the rest of concrete by opening the cleaning hole at the bottom of the hopper. Clean the s-valve, hopper, conveyor cylinders, water box with water. Clean the complete concrete pump and spray it with oil or diesel fuel.
8. You have to drain the water box, the water tank and the water pump, if they could freeze. The water box must be drained during long pumping breaks, over night time, on weekends, also at normal temperatures.

## 3.4 Cleaning

### 3.4.1 Cleaning by suction

1. Pump the hopper empty up to the upper edge of the conveyor cylinders.
2. Push a cleaning sponge (cube), which is filled with water, into the end hose of the pipeline.
3. Suck the cleaning sponge back to last conveyor pipe in front of the hopper. By knocking on the conveyor pipe with a hammer, you can check the position of the sponge (different sounds). Switch off the pump.

## 3.4.2 Cleaning with pressure water

You need some experience to clean the machine with pressure water.

1. Pump the hopper empty as far as possible. Suck 2 or 3 strokes back - pressure relief for conveyor pipes. Switch off the pump.
2. Open the cleaning hole of the hopper and take out the rest of concrete.
3. Open the conveyor pipe in front of the hopper or the cleaning hole of the conveyor pipe (in this case you have to lock the rest of the concrete pipes). Spray water with the spray nozzle in direction to the hopper.

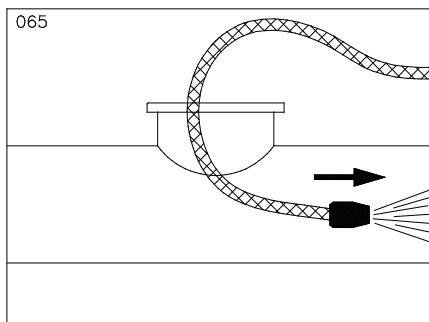

Start SUCTION. Be carefully that the s-valve doesn't cut the water hose during tilting. Spray with water as long as clean water comes out of the conveying cylinders. Stop SUCTION. Clean the complete hopper and s-valve.

4. Push 2 or 3 with water filled sponge balls inside the conveyor pipeline and connect it to the hopper again. (If you locked the rest of the pipes, you have to open it now). Lock the cleaning hole of the hopper and fill the hopper with water.

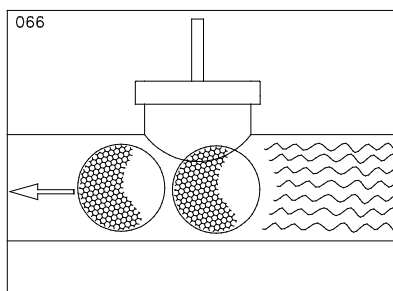

5. Pump the sponge balls through the conveyor pipes, until they come out at the end hose. If the water inside the hopper is not enough for the complete pipeline, you have to fill it, before the system sucks air. Be carefully that the cleaning water can not run inside the sheeting.
6. Suck the water back into the hopper.
7. S-valve and agitator will stop, if you open the hopper grid, in case of safety stop, assembled at the grid. Lock the grid during cleaning the pipeline. Don't open the bolts during cleaning, If the hopper grid is assembled with screws.
8. Take out the water by opening the cleaning hole at the bottom of the hopper. Clean the s-valve, hopper, conveyor cylinders, water box with water. Clean the complete concrete pump and spray it with oil or diesel fuel.
9. You have to drain the water box, the water tank and the water pump, if the water could freeze. The water box must be drained during long pumping breaks, over night time, on weekends, also at normal temperatures.

# Operation of the concrete pump

## 3.5 Conversion and replacement of wear parts

### 3.5.1 Replacement of wear plate and wear ring

**ATTENTION:** Always stop the engine and remove the ignition key if you work inside the hopper or in the surroundings of the tilting cylinders.

1. Remove safety plate (1) at the tilting lever. Release the s-valve by opening the screws (2) und (3) for about 15 mm.

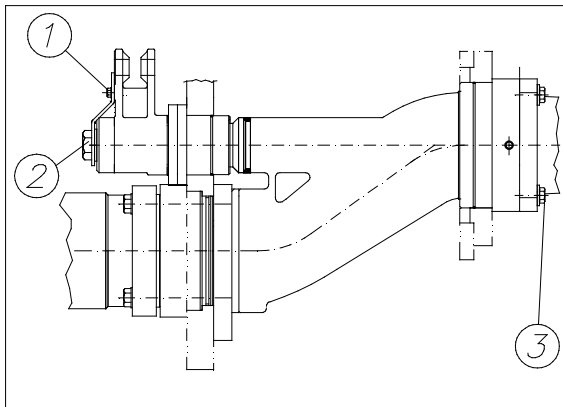

2. Exchange the released wear plate by removing the 4 screws (4) and tighten the bolts again.

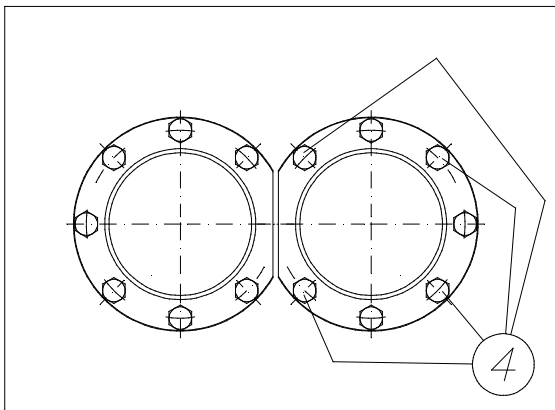

3. Swing the s-valve to the other side..

4. Take out the second wear plate by removing the 4 screws (4).
  5. Swing the s-valve back and exchange the wear ring (5).
  6. Swing the s-valve up to the mounted wear plate and assemble the second one.
  7. Give tension to the s-valve by tighten the 4 screws (3).
  8. Tighten the adjusting screw (2) by hand until there is no gap anymore. Release this screw for 1/6 at least and assemble the safety plate (1).
- ATTENTION:** Tighten the screws (3) and (4) with tightening torque. (See attached table for torque's).

9. Carry out a test run.



## 3.5.2 Replacement of conveyor pistons

**ATTENTION:** Always stop the engine and remove the ignition key if you work inside the water box. Do never grab inside the water box as long as the engine is running. Do the hydraulic cylinders drive always by using manual driving with the valves at the main control block. Use low r.p.m.

1. Drain the water box and remove the safety grid..
2. Move one drive cylinder by activating the valves Y3 and Y4 to end position.

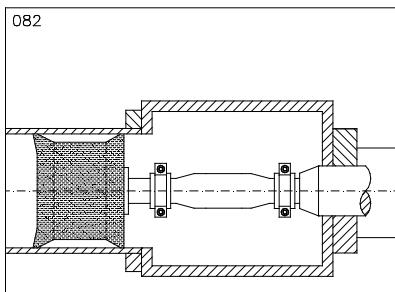

3. Open and remove the hose clamp and the clamp coupling.
4. Push the conveyor piston about 5mm in direction of conveyor cylinder and remove the spacer.

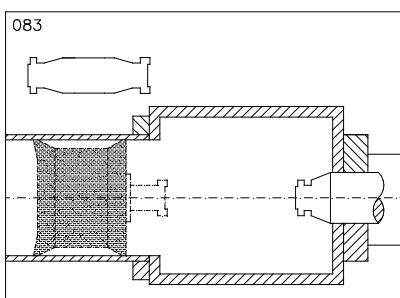

Drive the drive cylinder carefully out until the flanges touch each other and assemble a clamp coupling.

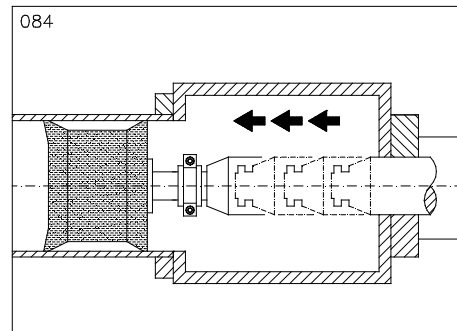

6. Bring the drive cylinder to end position and disassemble the clamp coupling and the piston.

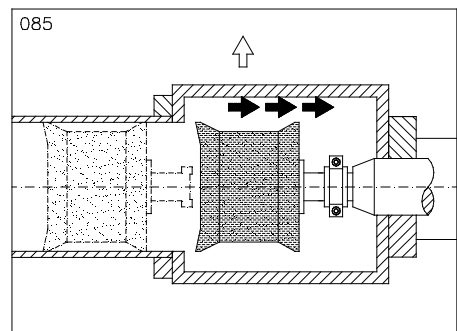

7. Lubricate the new conveyor piston well with grease and assemble it with one clamp coupling.

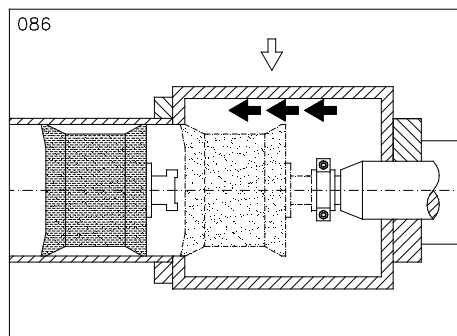

8. Drive the drive cylinder into the conveyor cylinder as long as there is enough space to assemble the spacer.
9. Remove the clamp coupling and drive the cylinder back to end position.
10. Assemble the spacer with the clamp coupling and the hose clamp onto the drive cylinder.

## Operation of the concrete pump

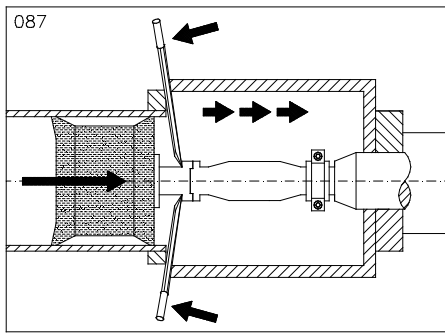

11. Push the piston in direction to the spacer and mount the second clamp coupling and clamp.

### 3.5.3 Replacement / turning of conveyor cylinders

1. Disassemble conveyor piston (see 3.5.3)
2. Bring both drive cylinders hydraulically to end position:  
Open the hydraulic swing hose at the driven in drive cylinder and fix a bucket at the hose.
3. Disassemble the axle and support the water box.
4. Remove the 28 screws (1) at the 4 flanges of the two conveyor cylinders and support the cylinders. (The easiest way would be with the fork lift)

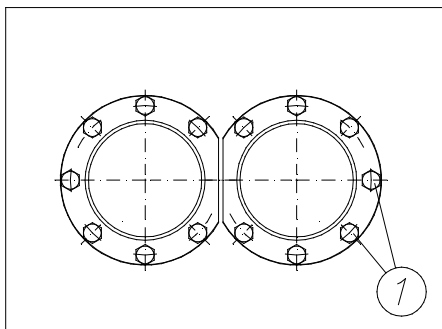

Lift the hopper by crane.

**ATTENTION:** Take care that you don't squeeze hydraulic hoses or electrical cables during lifting.

5. Disassemble or turn the conveyor cylinders.  
**Hint:** In order to increase the life time of cylinders you can turn them for 180°. It is very important to turn the cylinders in time,

before the wear out is too big, because than you have to exchange them completely.

6. Assemble the conveyor cylinders in opposite order.
7. Assemble the pistons (see 3.5.3) and the hydraulic swing hose again.
8. Drive the right drive cylinder out by activating the valves Y4a and Y3. (look at 3.1.4)
9. Take out the air from the swing hose. (see 3.1.4)
10. Start a test run.

### 3.5.4 Replacement of the agitator tool

1. Remove the cylindrical screws (6).
2. Push the shaft (3) against the motor (1).
3. Exchange the agitator tools (2 and 5).
4. Assemble the screws (6) and tighten it.
5. Fill the inner hex gap of the cylindrical screws with silicon to protect against concrete .

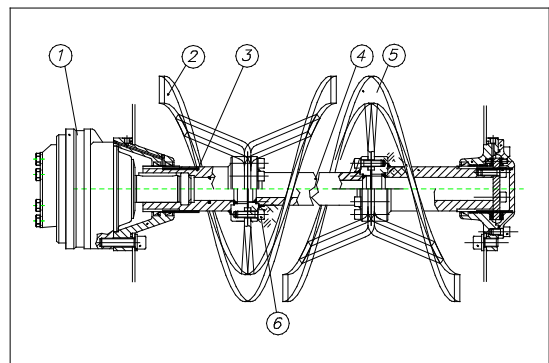

## 4 Maintenance

### 4.1 General hints

1. Maintain all technical units (e.g. truck) as the producer suggest you.
2. Pay attention to the safety hints written in the chapter 2 and 3 of this Operation Manual.
3. All Concrete Pumps must be checked for Operation Safety at least once a year by an authorised staff. (see chapter 2)

### 4.2 Daily maintenance

1. Check the oil-, fuel-, grease-, water levels and refill if necessary. Take care that the Pump is set up horizontal.
2. Check all parts which come in contact with concrete and exchange worn out parts..
3. Check the wear out of the conveyor pipes by knocking or with a wall thickness tester and exchange worn out pipes. For minimum wall thickness see the diagram at chapter 2.
4. Check the function of grease pump. Lubricate the bearings of tilting cylinders and the conveyor pistons.
5. Visual control of the hydraulic hoses and pipes and the fittings for leakings.

### 4.3 After the first 50 operating hours

1. Maintenance the truck according to the „Operation Manual“ from the truck producer.
2. Maintenance the concrete distributor boom according to the „Installation manual“ from the concrete distributor boom producer .
3. Clean all filter elements, respectively exchange them if necessary.

4. Check all screws for the tightening torque.(torque's see at chapter 3.6)

### 4.4 Weekly maintenance

1. Carry out the daily maintenance.
2. Lubricate all grease nipples and sliding surfaces.
3. Check the seals at s-valve and agitator by visual control.
4. Drain the condensation water at the ball gate of hydraulic tank.

### 4.5 Every 100 operating hours

1. Carry out the weekly maintenance.
2. Exchange the hydraulic filter element inside the hydraulic oil tank and clean the solenoid rod.

**ATTENTION:** Use only original parts.

Order numbers see in the Spare Part Book

3. Clean the diesel fuel prefilter.
4. Clean the air filter housing..
5. Check the pressure settings according to the data sheet.
6. Check the engine r.p.m. and the general function of hydraulic pump.
7. Check the clamping of the conveyor pistons.

# Maintenance

with rest surface 30µm for 180°.

## 4.6 Every 500 operating hours

1. Carry out the 100 hours maintenance
2. Drain the hydraulic oil, clean the tank, refill it with new hydraulic oil according to lubrication list 4.9.
3. Exchange the oil filter element.
4. Check the wear out at the s-valve wall thickness.(minimum 4mm)
5. Wear out control at the conveyor cylinders. Turn hardened cylinders at 2mm wear out (4mm in diameter) and chromized cylinders

## 4.7 Every 1000 operating hours

1. Carry out the 500 hours maintenance.
2. An authorised expert has to check all mechanical and hydraulically parts.
3. Check all safety facilities for properly condition.
4. Check the pulling loop, support wheel, outriggers. Control the tightening torque's for all screws.

## 4.8 Tightening torque's for screws

Following values are valid for grub screws threaded part way (DIN 912, 931 and 934) and sliding factor  $\mu = 1,25$  (light oiled).

thread size	tightening torque 8.8 Nm	tightening torque 10.9 Nm
M8	23	32
M10	46	64
M12	80	110
M14	125	180
M16	195	275
M18	270	390
M20	385	540
M22	510	720
M24	660	930
M27	980	1400
M30	1350	1850

## 4.9 Lubrication

The Waitzinger concrete pumps are equipped with several areas which require lubrication .

### **A.Lubrication of boom and outriggers**

The lubricating instructions and the lube points of boom and outriggers are described in the „Installation manual“ of the boom - section C .

### **B.Lubrication of concrete pump**

In order to insure a long life of the components it is necessary to lubricate carefully each lube point of the pump .

Use only lubricants NLGL - class 0-2 .

The critical lube points are connected to the central lubrication distribution block and fed by the automatic lube pump .The reservoir of the grease pump must be checked and refilled if necessary on a daily basis .

For areas not connected to the automatically lube system , use a manual lube pump and pump a sufficient number of strokes to ensure thorough lubrication of each point . Wipe off any excess lubricant .

### **C.Lubrication of conveying pistons .**

The conveying cylinders are equipped with a grease fitting at the end of tubes next to the flush box. Lube the conveying pistons when the pistons are retracted to end position ( Piston connection is visible in the flush box ) . The conveying pistons must be lubricated daily .

Optional the conveying cylinders are equipped with a automatically lubrication . In this condition the lubricant for the conveying pistons is hydraulic oil .

### **D.Inspection of the central lubrication system .**



The central lubrication system must be checked every day for :

- filling level of reservoir , so that no air can come to the pump inlet element . If the pump operates but the pump element does not deliver lubricant , the lubrication of lube points is defective . The used lubricant does not have the correct viscosity or air pockets are at the inlet of the pump element . Disconnect the main delivery line from the pump element outlet and operate the pump continuously until the lubricant is delivered without air pockets or change the lubricant if it would be necessary .

- blockage in the distribution system . If lubricant is discharged from the relief valve outlet of the pump or the indicator pin assembled at the grease distributor doesn't move ( the control pin should move itself very slowly in and out during working grease pump ) , the lubrication system is blocked . The blockage must be traced and cured .

# Maintenance

## 4.10 Lubricants

	motor summer 	motor winter 	hydraulic oil standard	hydraulic oil tropical countries
type	HD SAE 30	HD SAE 10W	HLP 46	HLP 100
Aral	Aral Super Kowal Aral Turboal	Multi Turboal 15W40	Vitam CF 46	Vitam CF 100
BP	Vanellus- T Energol HD-S	Visco Static	Energol HLP 46	Energol HL P10
ELF	Performance 2B Performance 3C	Multiperformance 3C	Olna 46	Olna 100
Esso	Essolube HDX Essolube HDX plus	Essolube XD 3	Nuto H 46	Nuto H 100
Fuchs	Renolin HD Titan HD-Super	Titan Universal HD	Renolin B 15	Renolin B 30
Mobil	Delvac 1230	Delvac 1210	DTE 25	DTE 27
Schell	Retolla X Rimula X	Myrina 15W40	Tellus Öl 46	Tellus Öl 100
Fanal	Super HD Motoröl HD Motoröl	Indol C	Salvo MWS 46	Salvo MWS 100

 pay attention to the regulations of the engine producer

lubrication points: use general purpose grease, acid free.

slip planes: use graphite lubricant

grease system: use only lubricants NLGL-class 0 - 2.  
See documentation of grease system.



### 5 Trouble Shooting

#### 5.1 Truck engine does not start

(see Operation Manual of truck)

#### 5.2 Pump unit does not start (without hydraulic pressure)

possible reason		remedy
1. hydraulic oil is too hot	☞	cool down hydraulic oil (see 3.3.3) Attention: do never cool down the hydraulic tank with water!
2. burnt fuses	☞	search for the reason of short circuit exchange the burnt fuses
3. amplifier out of order	☞	turn switch of spare function to position A check the amplifier
4. switch for stroke number is in minimum position	☞	increase stroke number
5. wiring problem at the cable loop	☞	check the cable loop
6. solenoid Y3 is damaged	☞	exchange the solenoid
7. solenoid Y6 at the main pump is damaged	☞	exchange the solenoid

#### 5.3 Pump unit stops (at maximum pressure)

possible reason		remedy
1. concrete blocking in the conveyor pipeline	☞	release the blocked concrete by suction
2. fuses burnt	☞	exchange fuses
3. drive cylinders do not reach end position	☞	drive cylinders manual to end position and take out the air
4. sensors damaged	☞	turn switch of spare function to position B exchange the damaged sensors
5. wiring problem at the cable loop	☞	check the cable loop
6. solenoids Y4a or Y4b or Y5a or Y5b damaged	☞	exchange damaged solenoids

#### 5.4 Pump unit works with too low performance

possible reason		remedy
1. switch for stroke number is in minimum position	☞	increase stroke number
2. pressure reduce valve Y3 is dirty.	☞	push the valve Y3 several times by hand in order to take out the dirty parts.
3. parameter setting for amplifier N1 is false	☞ the	set parameter P3, P8, P9, P- according to description



## **Trouble shooting**

### **5.5 Agitator does not work**

<b>possible reason</b>		<b>remedy</b>
1. agitator tool is blocked	☞	move agitator several times in both direction in order to release the tool
2. pressure reduce valve of mobil control block is dirty	☞	block the agitator tool, in order to wash out the fouling

### **5.6 Hydraulic oil is getting too hot**

<b>possible reason</b>		<b>remedy</b>
1. agitator tool is blocked for a longer time	☞	release the tool and cool down the hydraulic system
2. pressure reducing valve Y3 is fouled	☞	activate the pressure reducing valve several times by hand, in order to wash out the fouling cool down the hydraulic system

### 5.7 Faulty operations

#### 5.7.1 Drive cylinders work with shortened stroke

possible reason		remedy
1. spare function is switched on	☞	switch off the spare function
2. parameter setting for amplifier N1 is false	☞	set parameter P6, P8, P9, P- according to the description
3. pressure switch is adjusted too low	☞	adjust the pressure switch to 290 bar
4. sensor S11 or S12 is always active	☞	exchange sensor, in order to work short time with spare function, you have to take off the plug from the damaged sensor

#### 5.7.2 Faulty operation of tilting cylinders

possible reason		remedy
1. spare function is switched on	☞	switch off the spare function
2. parameter setting for amplifier N1 is false	☞	set parameter P7 according to the description
3. amplifier is out of order	☞	exchange the amplifier; it is possible to continue work with spare function "A" for a short time
4. sensor is out of order	☞	exchange sensors; it is possible to continue work with spare function "B" for a short time

#### 5.7.3 Delayed switch over with pressure peaks

possible reason		remedy
1. parameter setting for amplifier N1 is false	☞	set parameter P6, P7, P8, P9, P- according to the description
2. sensor is out of order	☞	exchange damaged sensor

## Trouble shooting

### 5.7.4 Changing of stroke number is too fast / too slow

<b>possible reason</b>		<b>remedy</b>
1. parameter setting for amplifier N1 is false	☞	set parameter P5 according to description

## 5.8 Grease system does not work

### 5.8.1 Mixing wing does rotate

<b>possible reason</b>		<b>remedy</b>
1. grease has to high consistency	☞	use a suitable lubricant
2. lubrication point blocks	☞	remove blocking
3. grease distributor blocks	☞	exchange distributor
4. pumping element is damaged	☞	exchange pumping element

### 5.8.2 Mixing wing does not rotate

<b>possible reason</b>		<b>remedy</b>
1. start conditions are not fulfilled	☞	control system "ON", PUMPING "ON", activate grease system
2. wiring problems with cable loop	☞	check the cable loop
3. printed circuit board is out of order	☞	exchange the printed circuit board
4. grease system motor is damaged	☞	exchange motor

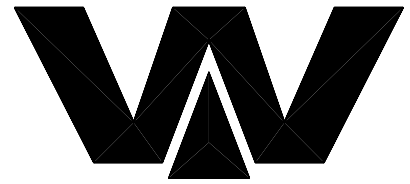

*Waitzinger  
Baumaschinen GmbH*

# *Ersatzteilliste*

## *spare part list*

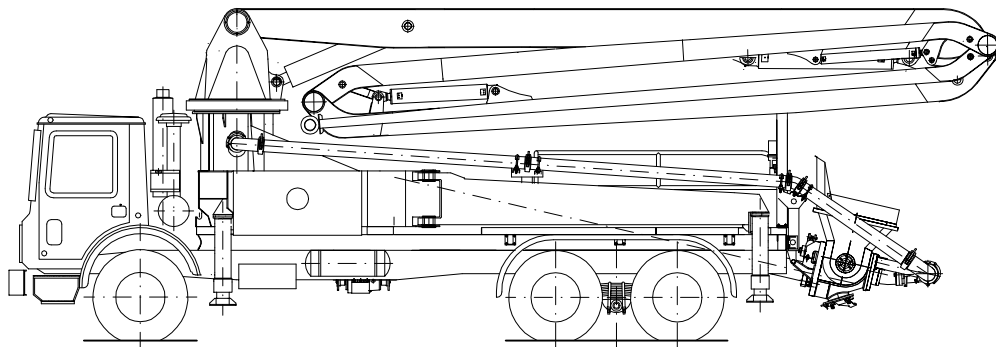

***36 R 4 XT***  
***Masch.-Nr. 204460***

*Übersicht B 00 - B 09*

*over view B 00 - B 09*

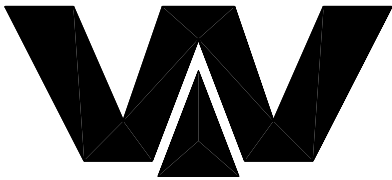

*Waitzinger  
Baumaschinen GmbH*

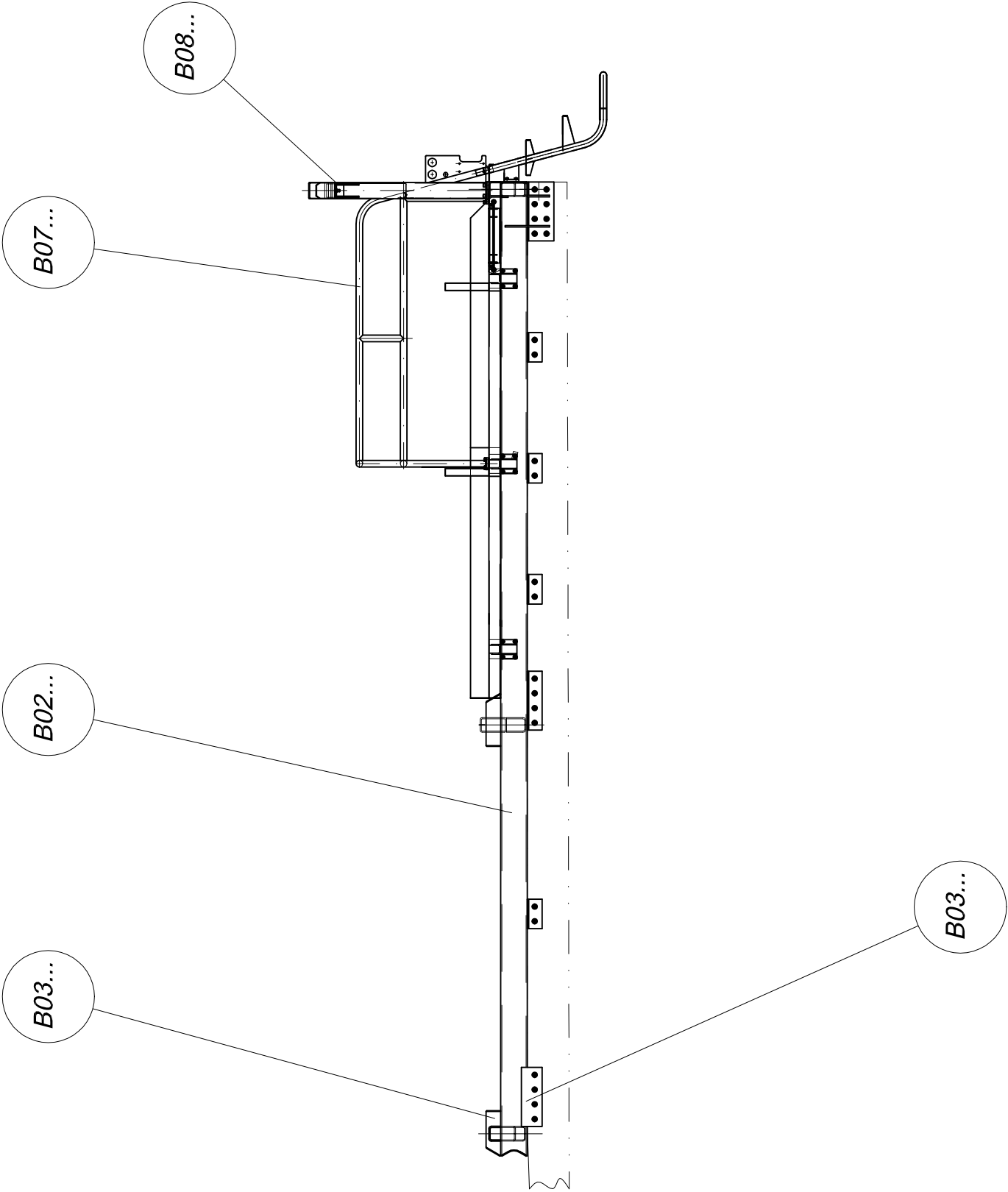

*Rahmen kpl.*

*frame cpl.*

*B 02 3 105*

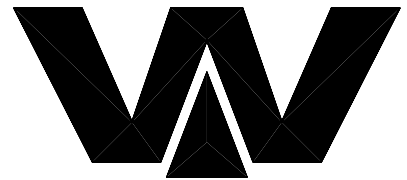

*Waitzinger  
Baumaschinen GmbH*

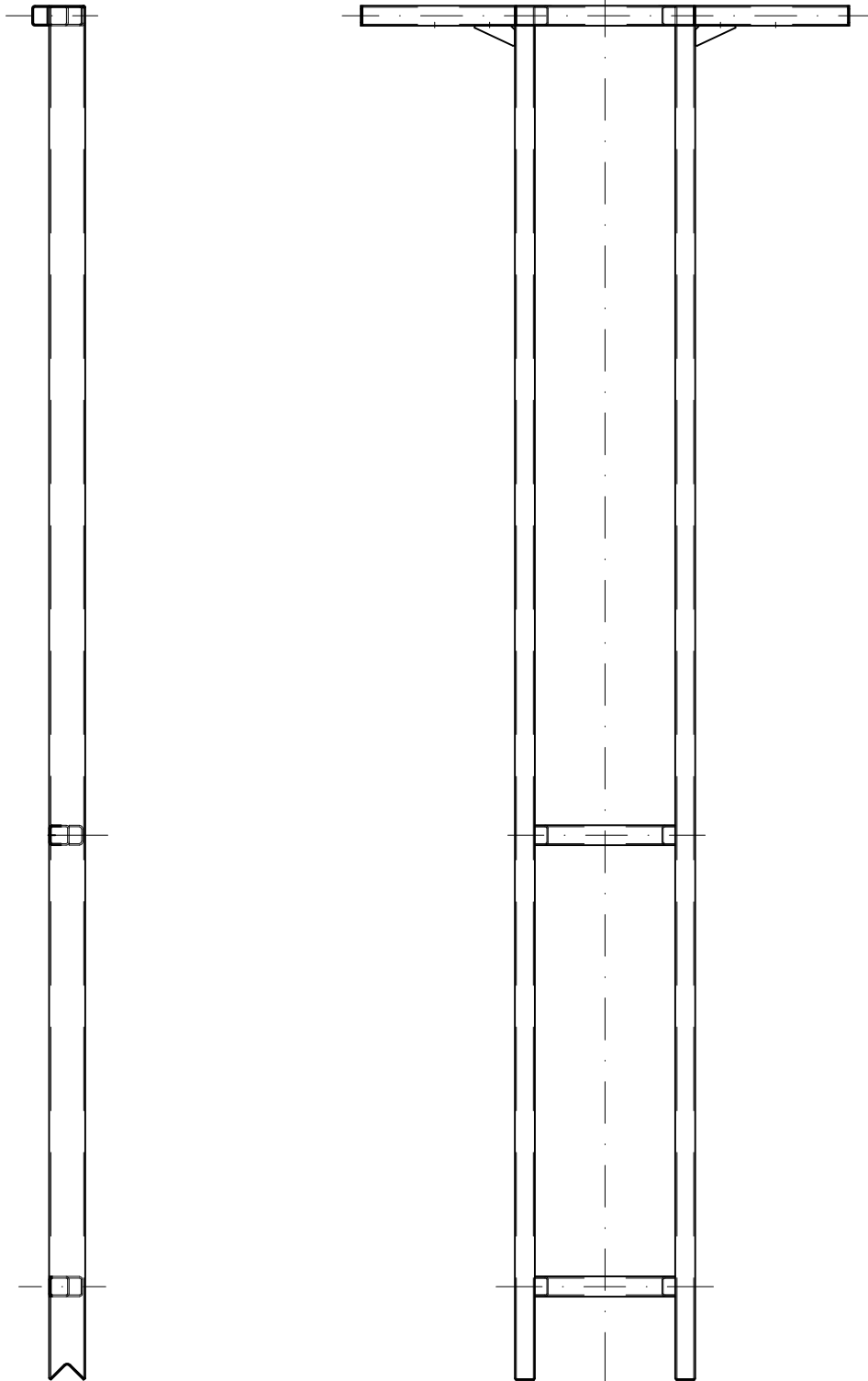

*Rahmenverbindung kpl.*  
*connection for boom base cpl.*

*B 03 8 010a*

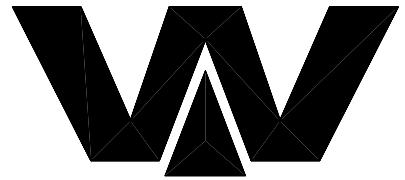

Waitzinger  
Baumaschinen GmbH

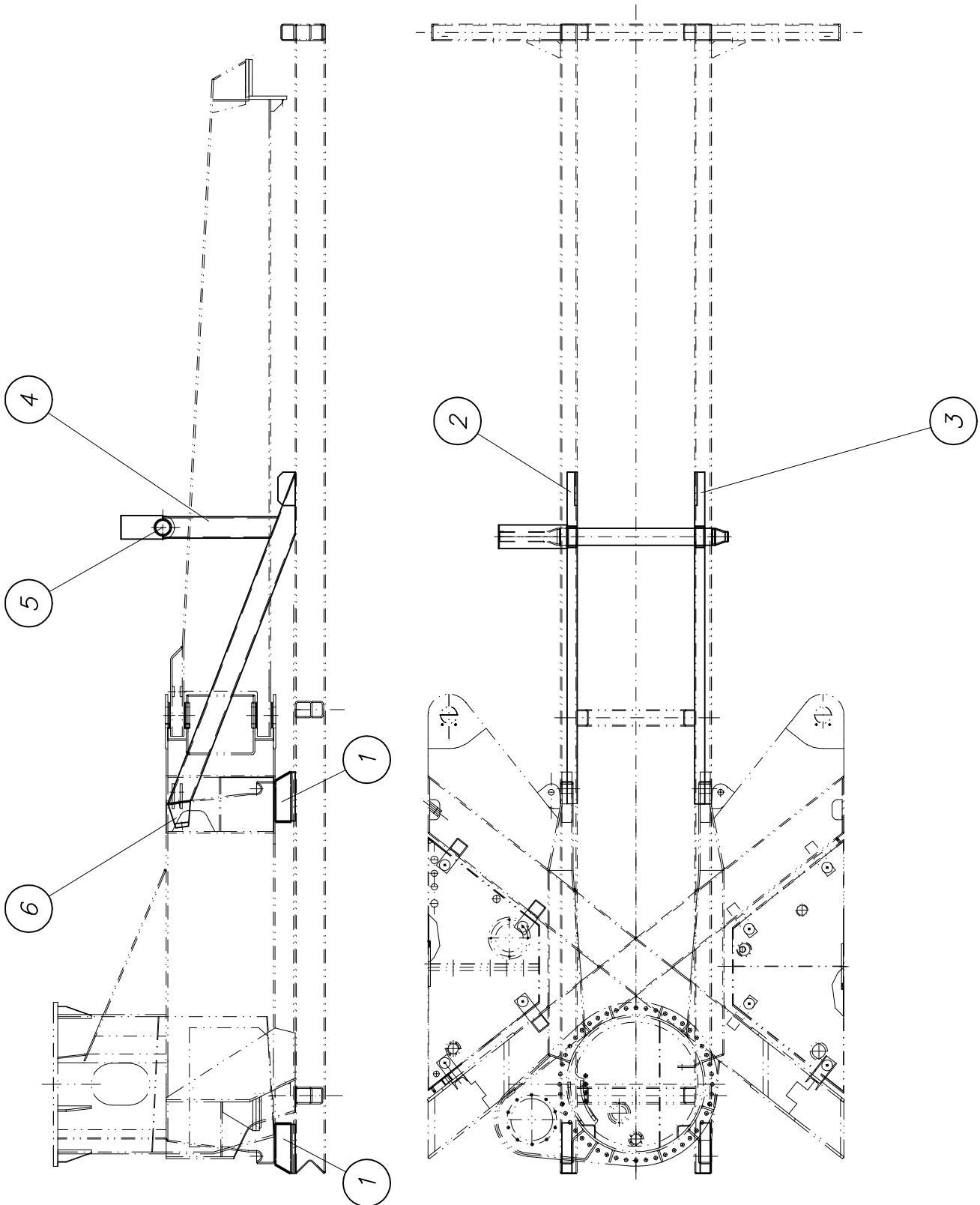



## PARTS LIST

<b>part list</b>	<b>description</b>	<b>created</b>	<b>index</b>	<b>valid from</b>	<b>valid to</b>	
B038010	connection for boom base col. xt	27.11.03 ute	a	04.02.05		
<b>pos</b>	<b>description stock</b>	<b>ident-no dimensions</b>	<b>DIN material</b>	<b>index</b>	<b>weighth Kg</b>	<b>quantity unit</b>
1	profil for boom support mounting own parts list	B033082				4,00 Stk
2	strut	B038001 MSH 120x60x8-21	59410 S355J2G3		45,00	1,00 Stk
3	strut	B038002 MSH 120x60x8x21	59410 S355J2G3		45,00	1,00 Stk
4	support	B038034 MSH 120x60x8x68	59410 S355J2G3		13,30	2,00 Stk
5	pipe (welding group) own parts list	B039035			28,00	1,00 Stk
6	bracket	b038003 BI 30x136x150	1543/EN10029 S355J2G3		3,70	2,00 Stk



*Podest und Aufstieg kpl.  
pedestal and ladder cpl.*

**B 07 4 465a**

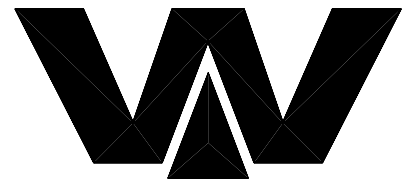

Waitzinger  
Baumaschinen GmbH

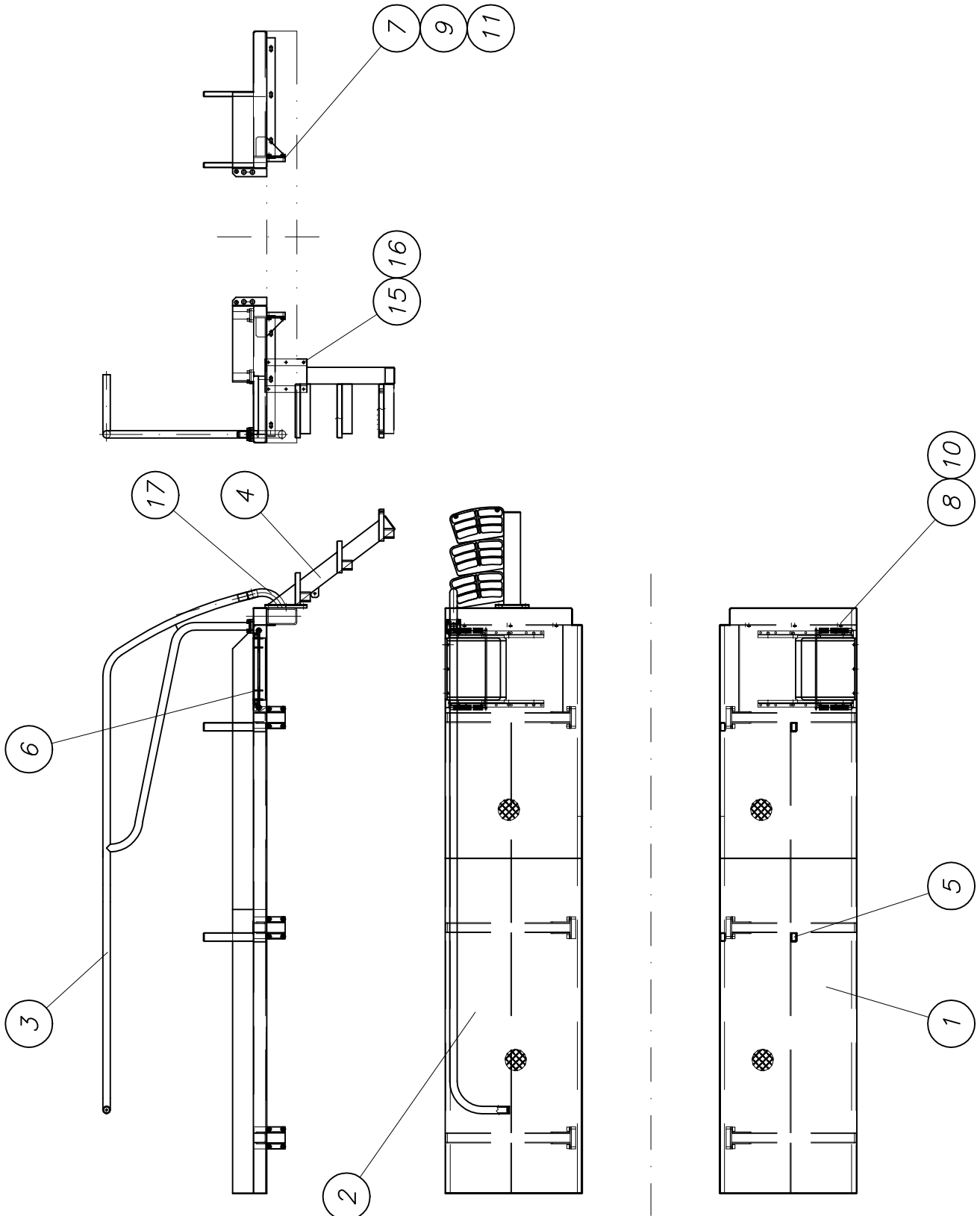



## PARTS LIST

part list	description	created	index	valid from	valid to	
B074465	pedestal a. ladder flat 37-Mtr XT boom	16.01.04 HF	a	23.03.04		
pos	description stock	ident-no dimensions	DIN material	index	weigh Kg	quantity unit
1	pedestal left cpl. 36-Mtr. boom REED own parts list	B074201		e 24.01.02	150,00	1,00 Stk
2	pedestal right cpl. 36-Mtr. boom REED own parts list	B074202		g 05.06.03	130,00	1,00 Stk
3	railing 37R4XXT own parts list	B074280				1,00 Stk
4	step cpl. own parts list	B074345		b 23.09.04	30,00	1,00 Stk
5	profil cpl. own parts list	B074145			1,50	2,00 Stk
6	flap cpl. own parts list	B074150		a 21.02.02	9,00	2,00 Stk
7	thread plate	B074247 BI 25x110x130	1543/EN10029 St37-2		2,50	6,00 Stk
8	hex. bolt M12 x 25 DIN 933 8.8	WAI101001			0,04	6,00 Stk
9	cheese head screw M 16 x 30	WAI102857				24,00 Stk
10	washer	WAI102962			0,01	6,00 Stk
11	spring washer A16	WAI102072			0,01	24,00 Stk
15	thread plate	B074346 BI 15x40x250	1543/EN10029 S355J2G3	a 23.03.04	1,20	2,00 Stk
16	hex. bolt M 12 x 20 DIN 933 8.8	WAI102999				6,00 Stk
17	pipe own parts list	B074470		a 22.03.04	2,00	1,00 Stk

*Klappe kpl.*

*flap cpl.*

*B 07 4 150a*

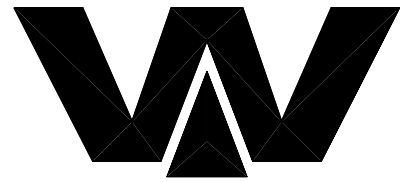

Waitzinger  
Baumaschinen GmbH

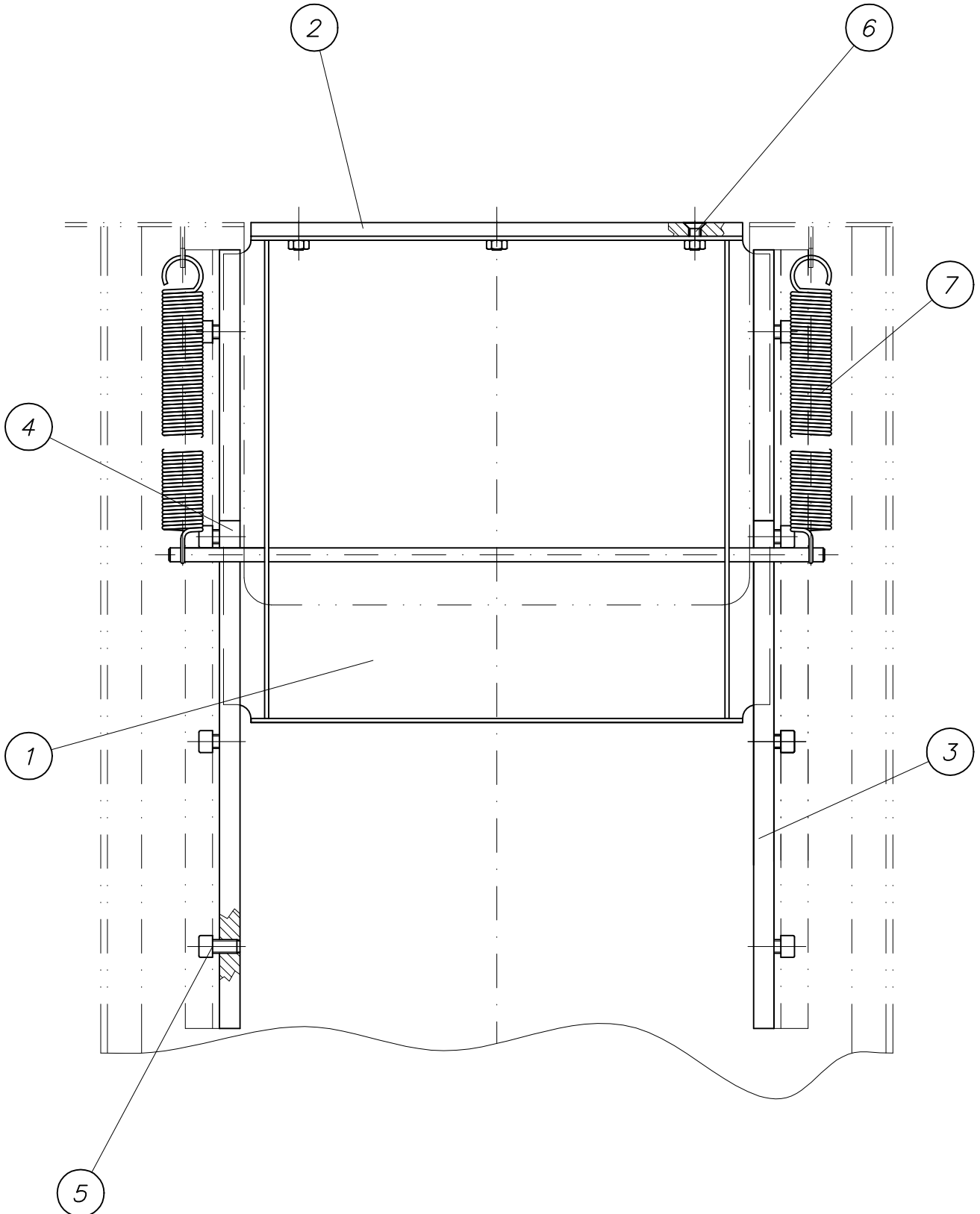



## PARTS LIST

part list	description	created	index	valid from	valid to	
B074150	flap cpl.	26.06.97 HG	a	21.02.02		
pos	description stock	ident-no dimensions	DIN material	index	weigh Kg	quantity unit
1	flap (welding group) for 32/36-Mtr. boom own parts list	B073121		a 18.04.97	5,10	1,00 Stk
2	contact strip	B074151 Platte 10x360x8	Polyamid		0,30	1,00 Stk
3	strip	B073124 Flachstahl 20x1	174 St37 K		1,40	2,00 Stk
4	stop	B073125 Flachstahl 20x1	174		0,05	2,00 Stk
5	cheese head screw M 10 x 20	WAI103287				8,00 Stk
6	sunk screw M 8 x 20	WAI103397				3,00 Stk
7	spring	WAI107209				2,00 Stk

*Mastauflagebock kpl.*  
*boom support cpl.*

*B 08 4 185*

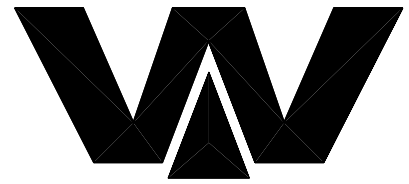

*Waitzinger*  
*Baumaschinen GmbH*

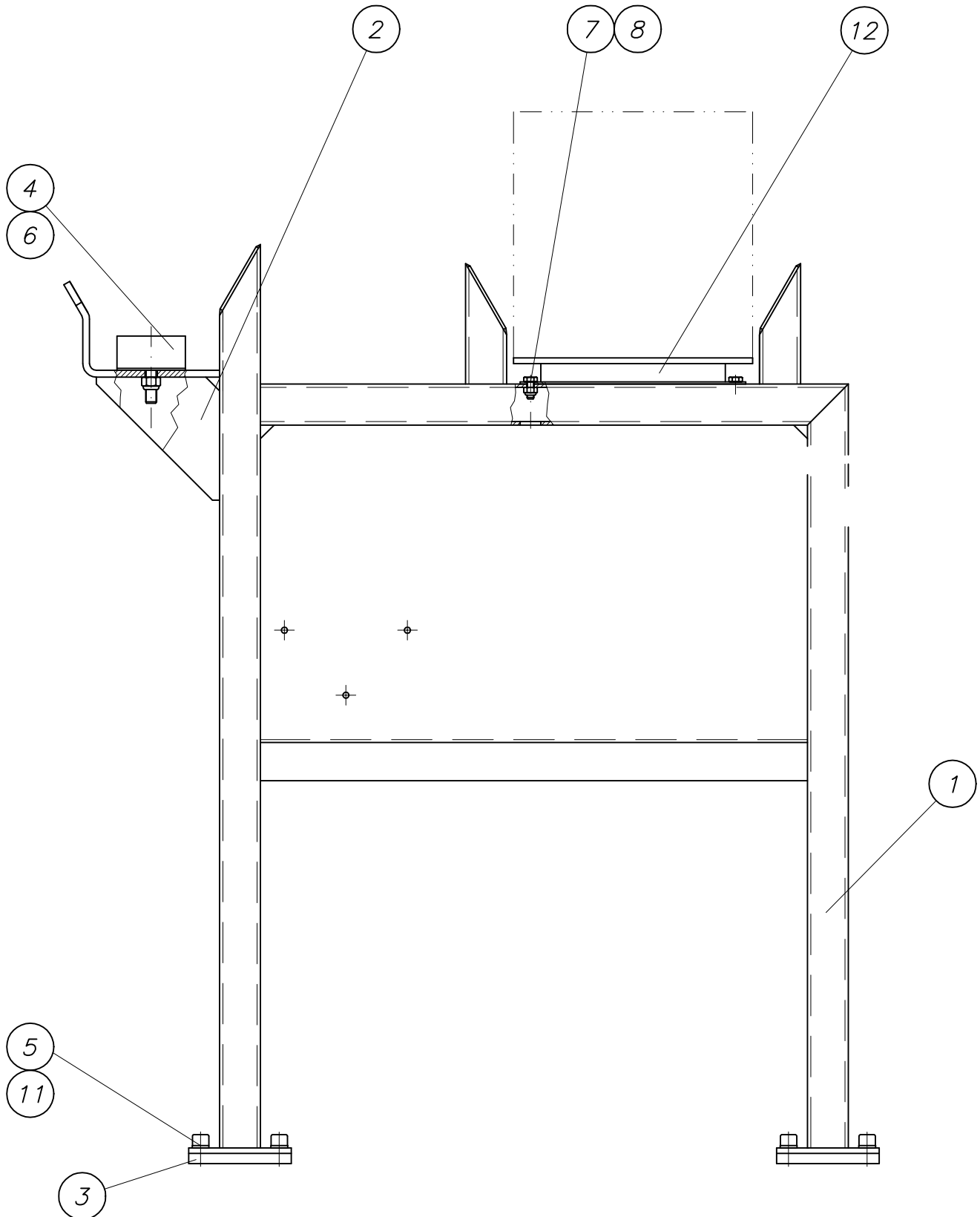



## PARTS LIST

part list	description	created	index	valid from	valid to	
B084185	boom support cpl.	14.03.01 Mi				
pos	description stock	ident-no dimensions	DIN material	index	weighth Kg	quantity unit
1	boom support (weld.) 36XXT own parts list	B084184		a 17.07.02	64,35	1,00 Stk
2	console cpl. for boom support own parts list	B084122			7,00	1,00 Stk
3	flange	B084102 FI 150x15x130	1017 St37-2		2,20	2,00 Stk
4	rubber buffer 100 x 50	WAI103478				1,00 Stk
5	cheese head screw M 16 x 25	WAI103488				8,00 Stk
6	nut M16 DIN 982	WAI103046				1,00 Stk
7	hex. nut M10 DIN985 8.	WAI102125			0,01	2,00 Stk
8	hex. bolt M 10 x 25	WAI101014			0,02	2,00 Stk
11	spring washer A16	WAI103489			0,01	8,00 Stk
12	rubber cushion	WAI104799				1,00 Stk

Übersicht B 10 - B 29  
over view B 10 - B 29

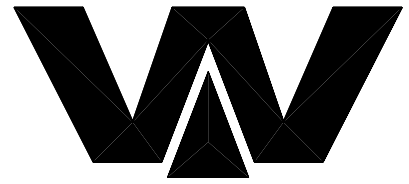

Waitzinger  
Baumaschinen GmbH

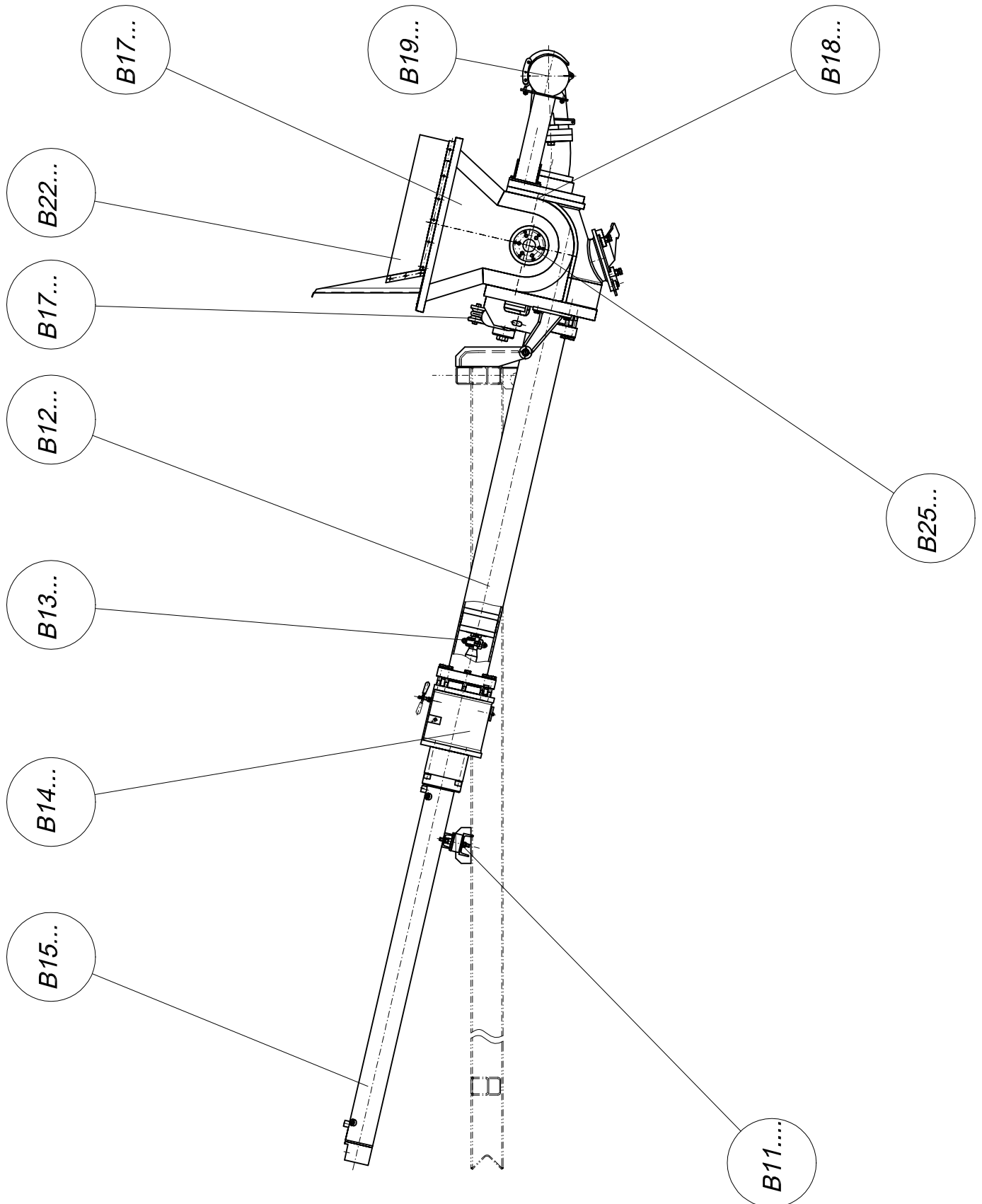

*Pumpenlagerung Steuerblock*  
*pump support control block*

**B 11 4 215**

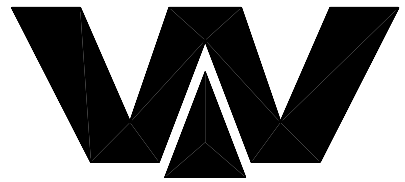

*Waitzinger*  
*Baumaschinen GmbH*

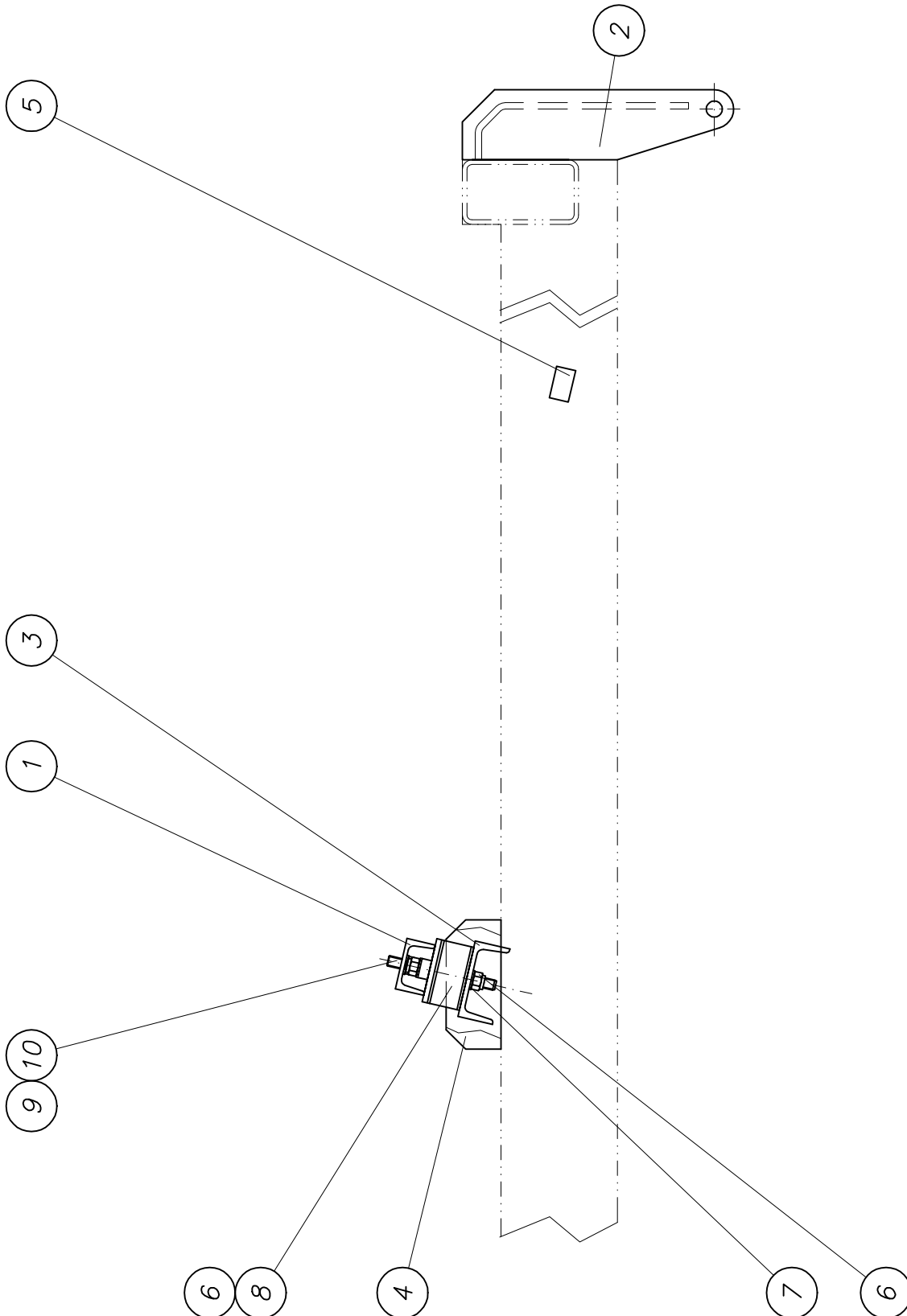





## PARTS LIST

<b>part list</b>	<b>description</b>	<b>created</b>	<b>index</b>	<b>valid from</b>	<b>valid to</b>	
B114215	pump support cpl. for control block	16.09.03 ute				
<b>pos</b>	<b>description stock</b>	<b>ident-no dimensions</b>	<b>DIN material</b>	<b>index</b>	<b>weigh Kg</b>	<b>quantity unit</b>
1	beam cpl. own parts list	B113015			6,30	1,00 Stk
2	bracket cpl. own parts list	B114153			10,70	2,00 Stk
3	cross profile	B114191 U 120x55x7x699	1026 St52-3		9,10	1,00 Stk
4	bracket	B114157 Bl 15x85x200	1543/EN10029 St52-3		1,86	2,00 Stk
5	lock bracket	B114158 Bl 25x30x50	1543/EN10029 St37-2		0,30	2,00 Stk
6	nut M16 DIN 985	WAI102330				4,00 Stk
7	washer 17, DIN 125	WAI102893				2,00 Stk
8	rubber buffer 100 x 55	WAI102713				2,00 Stk
9	hexagon bolt M16 x 30	WAI102892				2,00 Stk
10	spring washer A16	WAI102072			0,01	2,00 Stk

*Förderzylinder kpl.*  
*conveying cylinder cpl.*

*B 12 4 020*

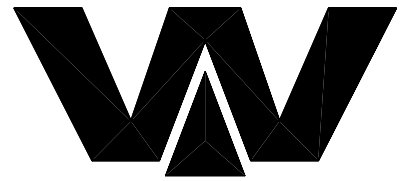

Waitzinger  
Baumaschinen GmbH

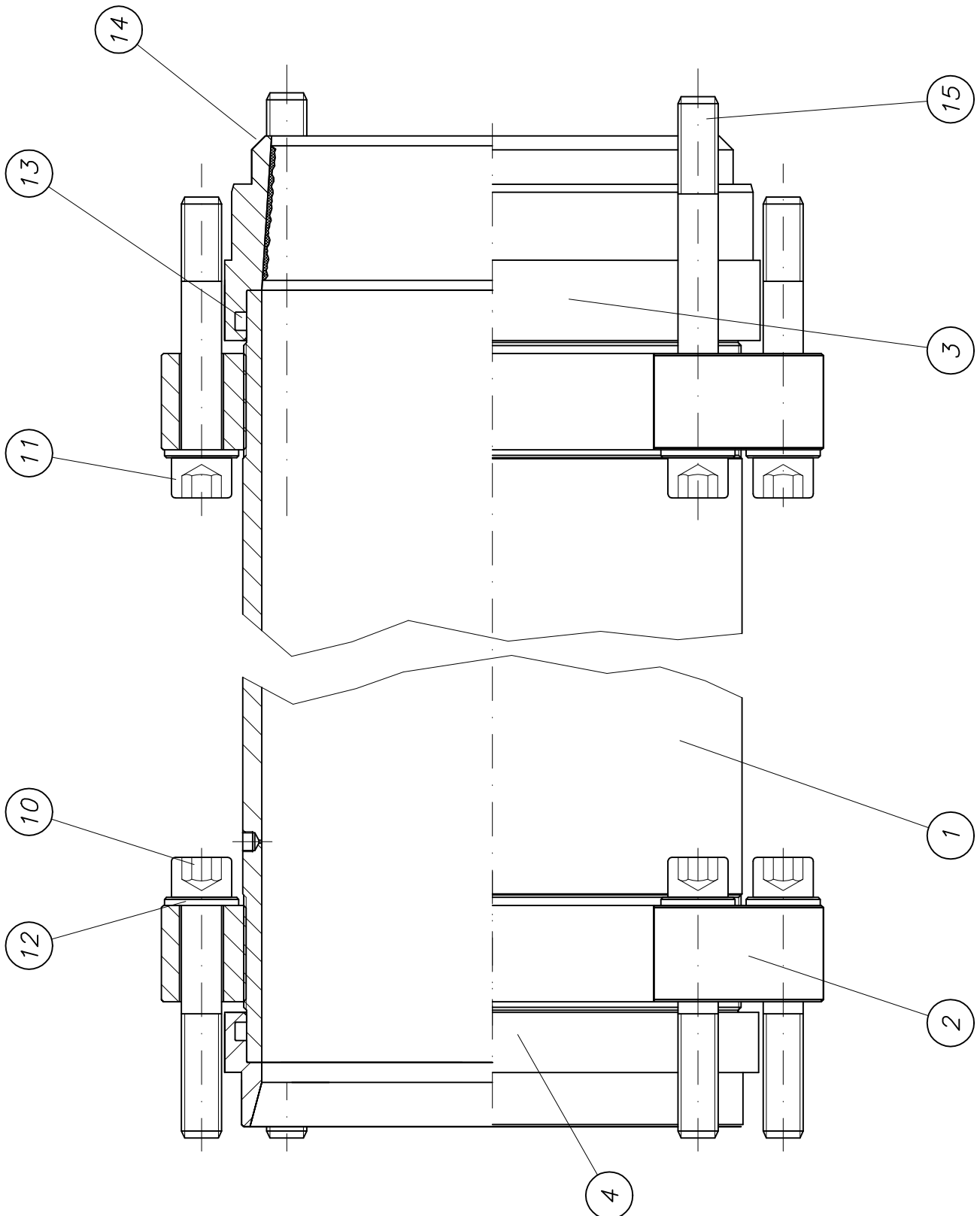



## PARTS LIST

part list	description	created	index	valid from	valid to	
B124020	conveyor cylinder cpl. DN230/215x2000	17.03.00 Mi				
pos	description stock	ident-no dimensions	DIN material	index	weighth Kg	quantity unit
1	conveyor cylinder DN230x2000 chromized	B124019 Rohr 250x12.5x2	2448 St52.0		150,00	2,00 Stk
2	flange ring DN 230 threaded	B124021 Bl 55xd330	1543/EN10029 St52-3		12,20	4,00 Stk
3	fitting ring DN230/215 with hardened	B124015 Rohr 267x35x108	2448 St52.0		8,88	2,00 Stk
4	fitting ring DN 230 water box	B123012 Rohr 267x36x65	2448 St52.0		6,00	2,00 Stk
10	cheese head screw M20 x 120	WAI103970				14,00 Stk
11	cheese head screw M20 x 130	WAI104885				6,00 Stk
12	washer HV	WAI100691			0,01	28,00 Stk
13	O-ring 244 x 7, NBR70	WAI102868				4,00 Stk
14	O-ring 230x5	WAI101090				2,00 Stk
15	cheese head screw M20 x 180	WAI102845				8,00 Stk

*Förderkolben kpl.*  
*conveying piston cpl.*

*B 13 3 020*

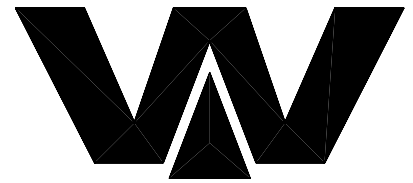

Waitzinger  
Baumaschinen GmbH

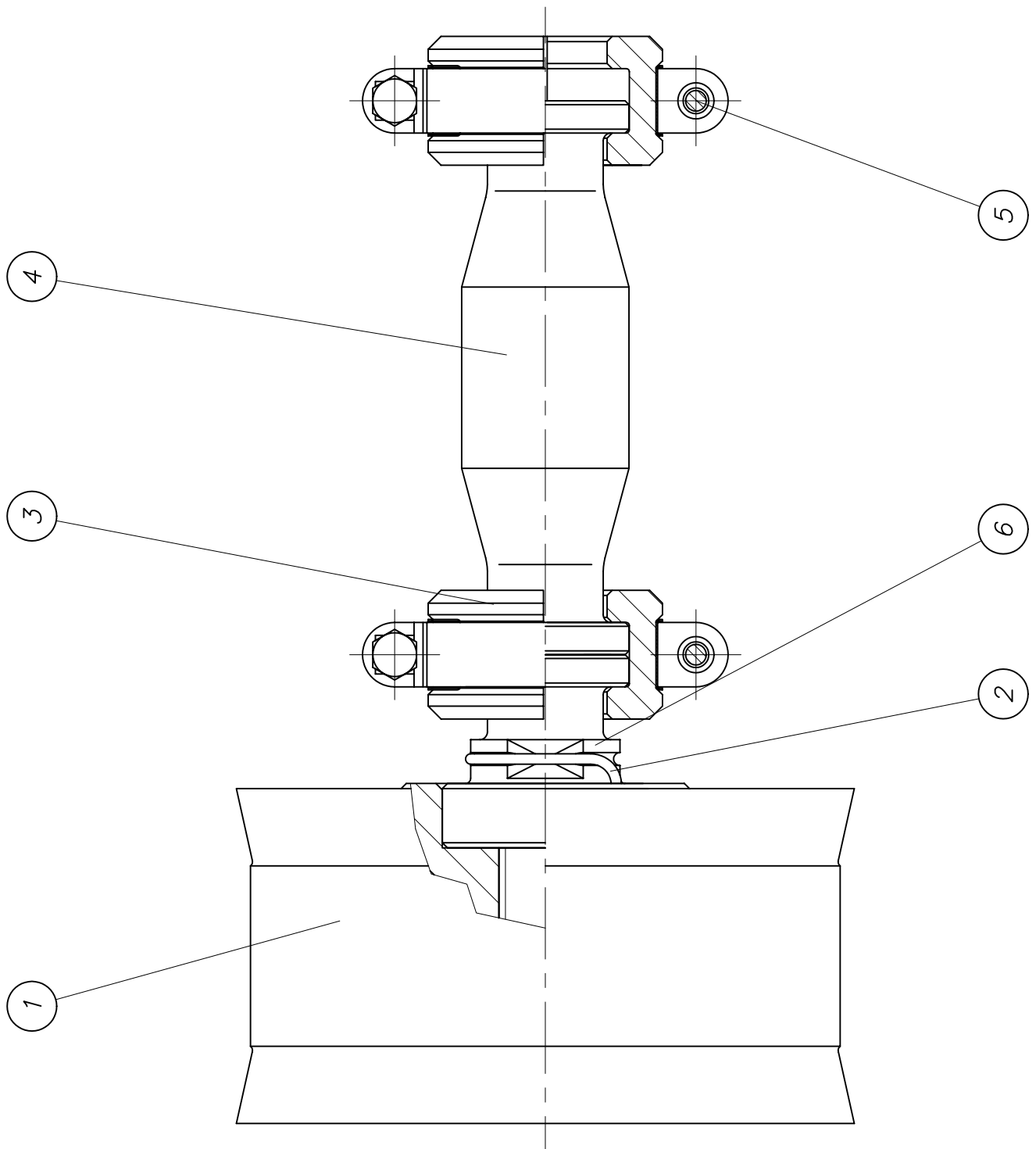

**PARTS LIST**

27.06.05 08:46:17

part list	description	created	index	valid from	valid to	
B133020	piston ram cpl. DN 230	08.07.98 Mi				
pos	description stock	ident-no dimensions	DIN material	index	weigth Kg	quantity unit
1	piston ram DN 230	WAI100175			19,90	2,00 Stk
2	protection ring	B133019 Federst. 4	17223			2,00 Stk
3	clamp coupling	B131004 Rd 95x50	1013 42CrMo4V			4,00 Stk
4	distance piece	B133003 Rd 70x225	1013 42CrMo4V			2,00 Stk
5	hose clamp S86/25	WAI101381			0,22	4,00 Stk
6	coupling bolt	B133018 Rd 82x120	1013 42CrMo4V		2,20	2,00 Stk

Spülkasten kpl.  
water box cpl.

B 14 3 000

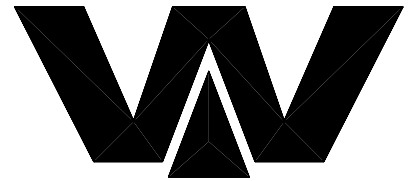

Waitzinger  
Baumaschinen GmbH

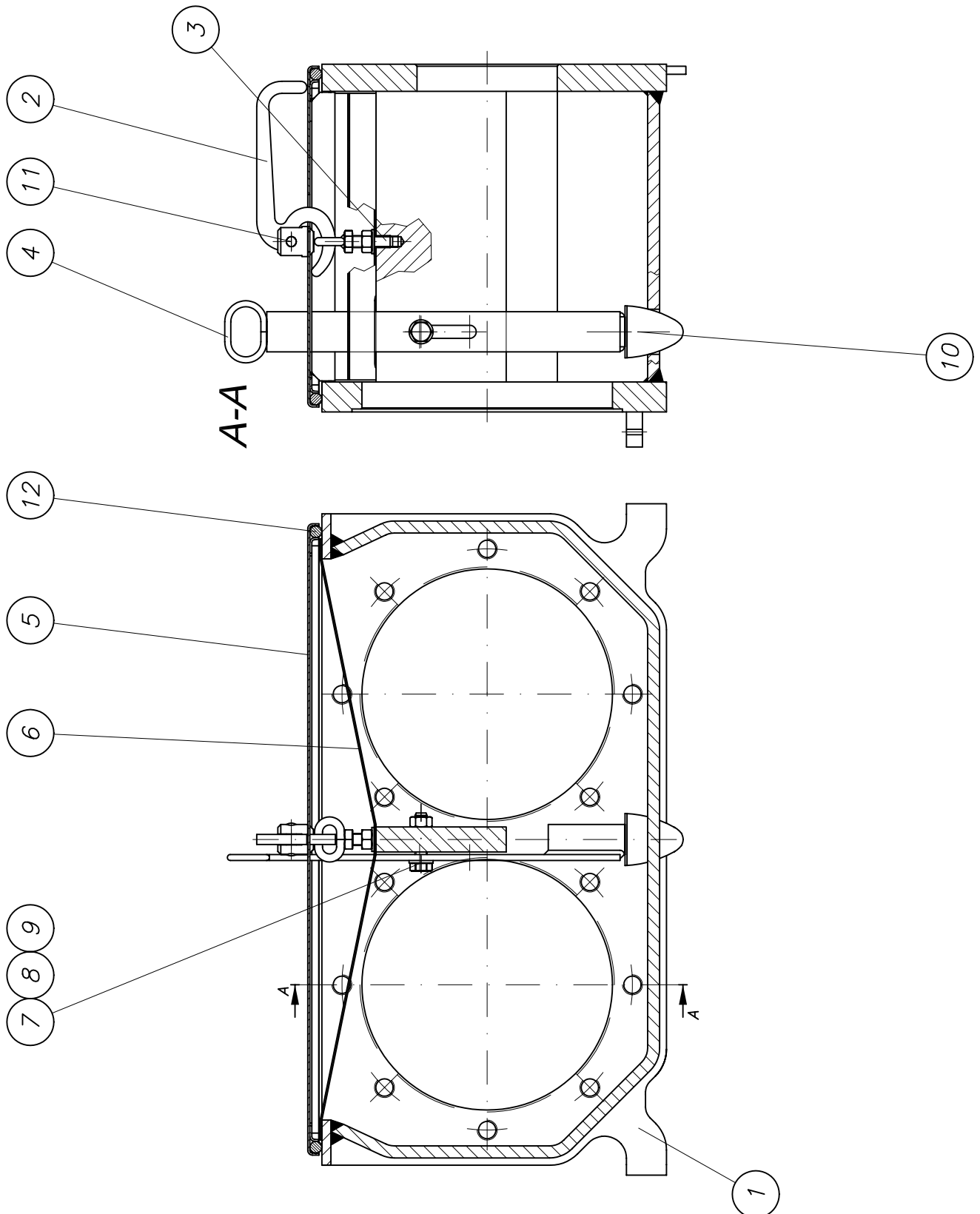



## PARTS LIST

part list	description	created	index	valid from	valid to	
B143000	waterbox cpl. DN 200/230 plug	19.06.97 HG				
pos	description stock	ident-no dimensions	DIN material	index	weighth Kg	quantity unit
1	waterbox cpl. DN 200/230 (processing) own parts list	B143001		b 02.05.00		1,00 Stk
2	lever	B143007 Bl 10x195x78.5	1543/EN10029 St52-3			1,00 Stk
3	loop bolt cpl. own parts list	B143009			0,09	1,00 Stk
4	drain pin own parts list	B143011			1,14	1,00 Stk
5	cover for waterbox cpl. own parts list	B143015			4,55	1,00 Stk
6	savety lattice	B143020 Lochbl. 1.5x610	Rostfrei	a 28.05.03		1,00 Stk
7	hex. screw M12	WAI103688				1,00 Stk
8	nut M12 DIN 934	WAI101557			0,02	2,00 Stk
9	washer	WAI100504				2,00 Stk
10	rubber buffer 50 x 58	WAI102712				1,00 Stk
11	pin	WAI103387				1,00 Stk
12	O-ring cord 12mm	WAI101831				1,95 Mtr







# PARTS LIST

part list	description	created	index	valid from	valid to	
B154032	drive cylinder cpl. 125/80-2000	20.09.00 Mi				
pos	description stock	ident-no dimensions	DIN material	index	weigh Kg	quantity unit
1	drive cylinder 125/80-2000 own parts list	WAI106355		a 30.10.03	280,00	2,00 Stk
2	cylinder head screw M 24 x 200	WAI103828				8,00 Stk
3	O-ring 129,2 x 5,7	WAI101441				2,00 Stk

*Antriebszylinder kpl.*  
*drive cylinder cpl.*

*WAI 106355a*

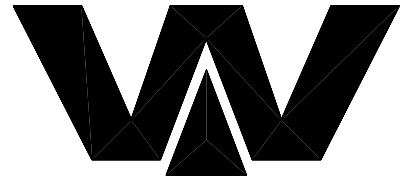

Waitzinger  
Baumaschinen GmbH

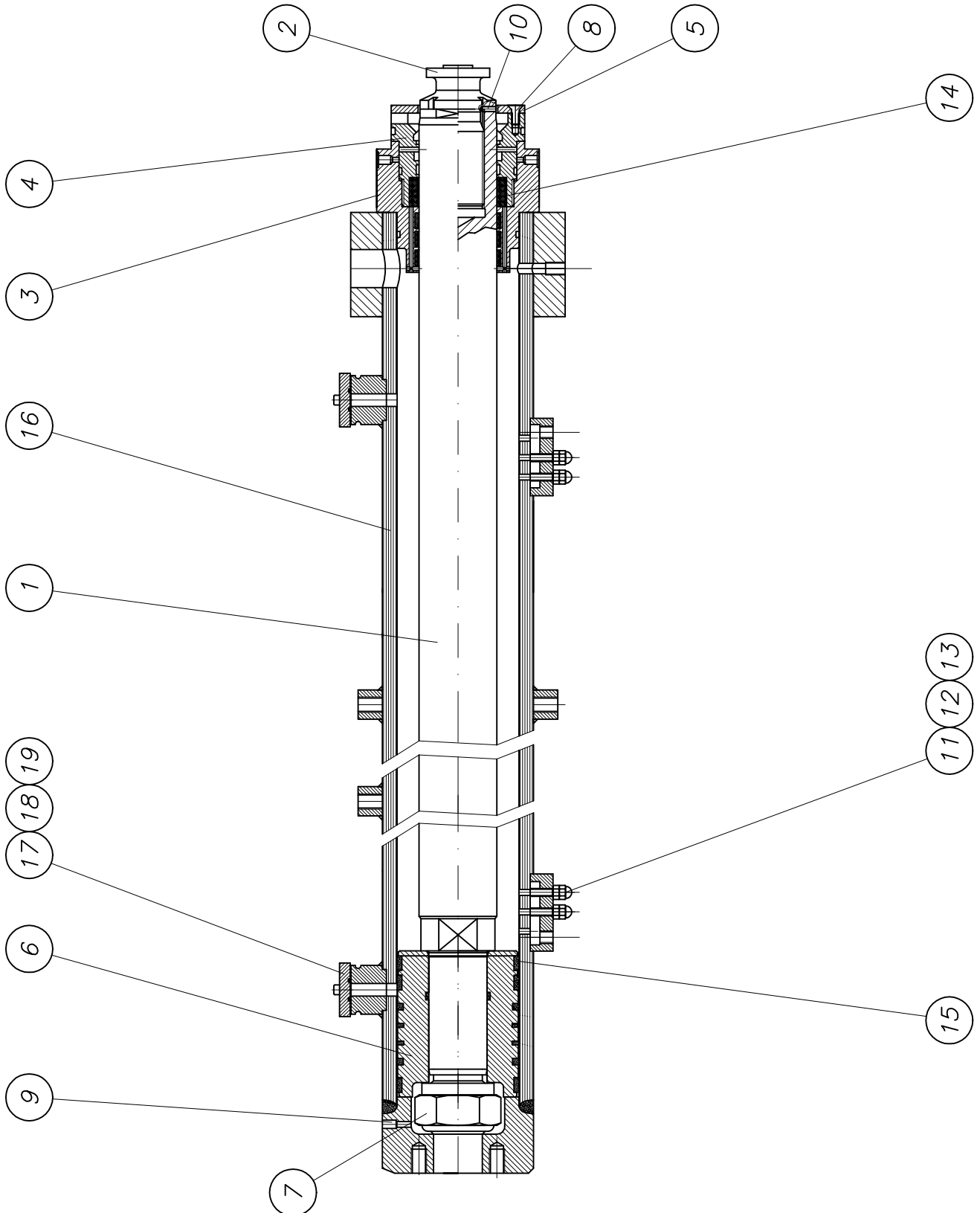



## PARTS LIST

part list	description	created	index	valid from	valid to	
WAI106355	drive cylinder 125/80-2000	06.09.00 hbk	a	30.10.03		
pos	description stock	ident-no dimensions	DIN material	index	weigh Kg	quantity unit
1	piston rod for drive cylinder	WAI105724 Rd 90x2173	1013 Ck45			1,00 Stk
2	piston joint	WAI104146 Rd 80x131	1013 42CrMo4V		1,87	1,00 Stk
3	guide piece for drive cylinder 125	WAI105950 Rd 180x142	1013 St52	a 21.07.03		1,00 Stk
4	sealing carrier for drive cylinder	WAI104890	GGG 40	a 29.07.03		1,00 Stk
5	aperture for drive cylinder	WAI105726 8x d137	Polyamid			1,00 Stk
6	piston 125	WAI106353		b 21.07.03	13,00	1,00 Stk
7	piston nut for drive cylinder	WAI105728				1,00 Stk
8	sunk screw M 8 x 20	WAI103397				3,00 Stk
9	locking screw G 1/8	WAI100528				3,00 Stk
10	set screw	WAI105739				1,00 Stk
11	hex. nut M8 DIN 934 8. VERZ.	WAI102880				4,00 Stk
12	cap nut M8	WAI104933				4,00 Stk
13	set screw	WAI105740				4,00 Stk
14	sealing set for drive cylinder 125/80 own parts list	WAI104690				1,00 Stk
15	sealing set for drive cylinder 125/80 own parts list	WAI106354				1,00 Stk
16	cylinder pipe cpl. 125	WAI106148		b 21.07.03		1,00 Stk
17	cover for sensor connection	B154017 Rd 11x55	1013 S235J2G3		0,20	2,00 Stk
18	o-ring	WAI108533				2,00 Stk
19	alien bolt M 6x25	WAI103673				4,00 Stk

*Stangendichtsatz*

*rod sealing set*

*WAI 104690*

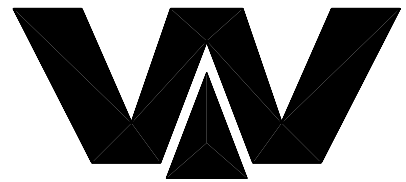

*Waitzinger  
Baumaschinen GmbH*

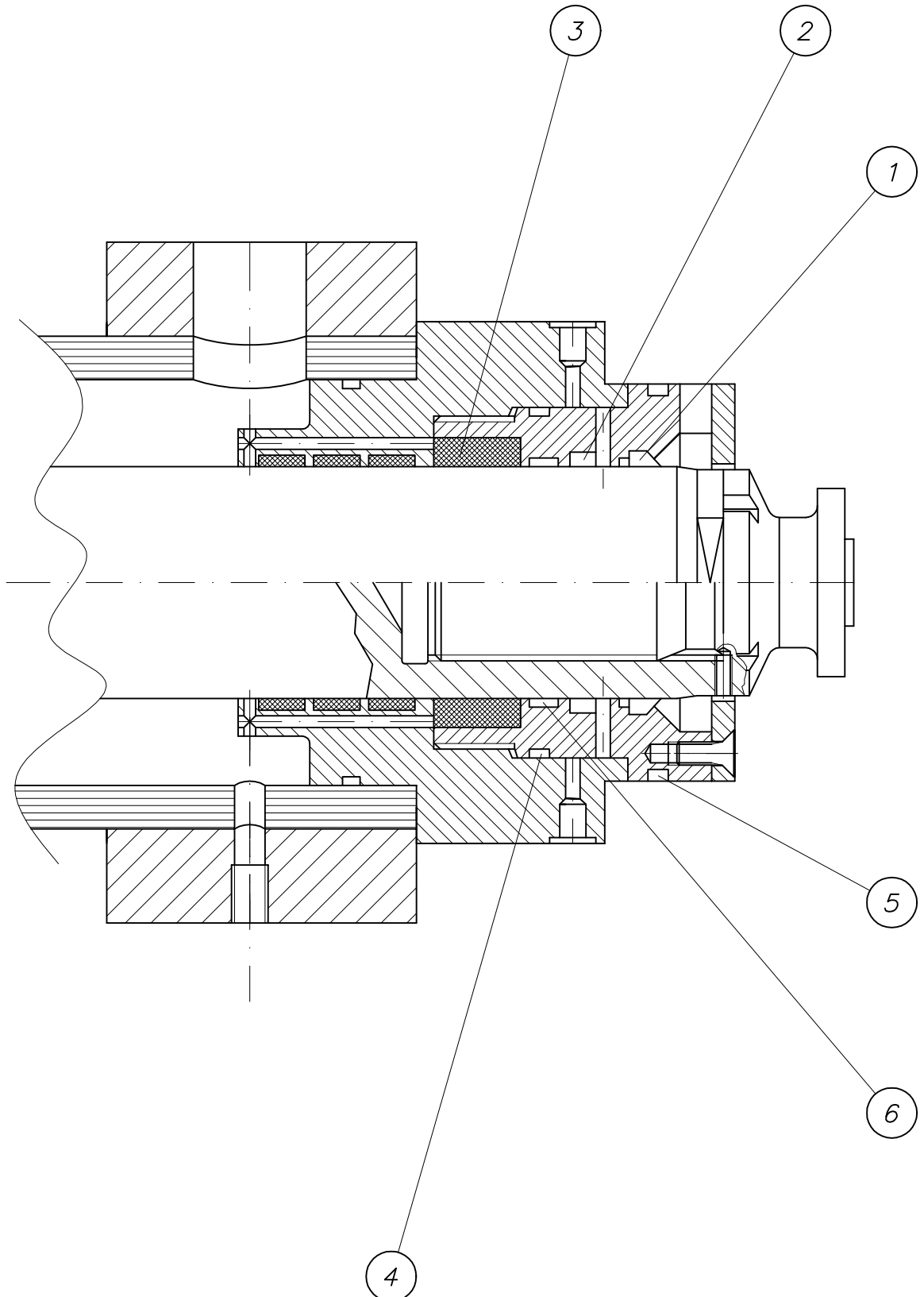



## PARTS LIST

part list	description		created	index	valid from	valid to
WAI104690	sealing set for drive cylinder 125/80		30.08.99 Mi			
pos	description stock	ident-no dimensions	DIN material	index	weighth Kg	quantity unit
1	wiper	WAI100259			0,00	1,00 Stk
2	wiper	WAI105729				1,00 Stk
3	v-packing 80 x 100 x 30	WAI102584				1,00 Stk
4	sealing for drive cylinder	WAI105732				1,00 Stk
5	o-ring	WAI105731				1,00 Stk
6	rod support for drive cylinder	WAI105738				1,00 Stk

*Dichtsatz für Antriebszylinder*  
*sealing set for drive cylinder*

*WAI 106354*

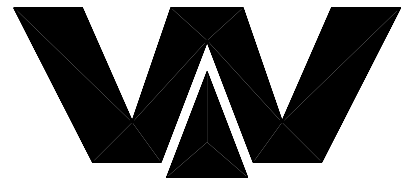

*Waitzinger*  
*Baumaschinen GmbH*

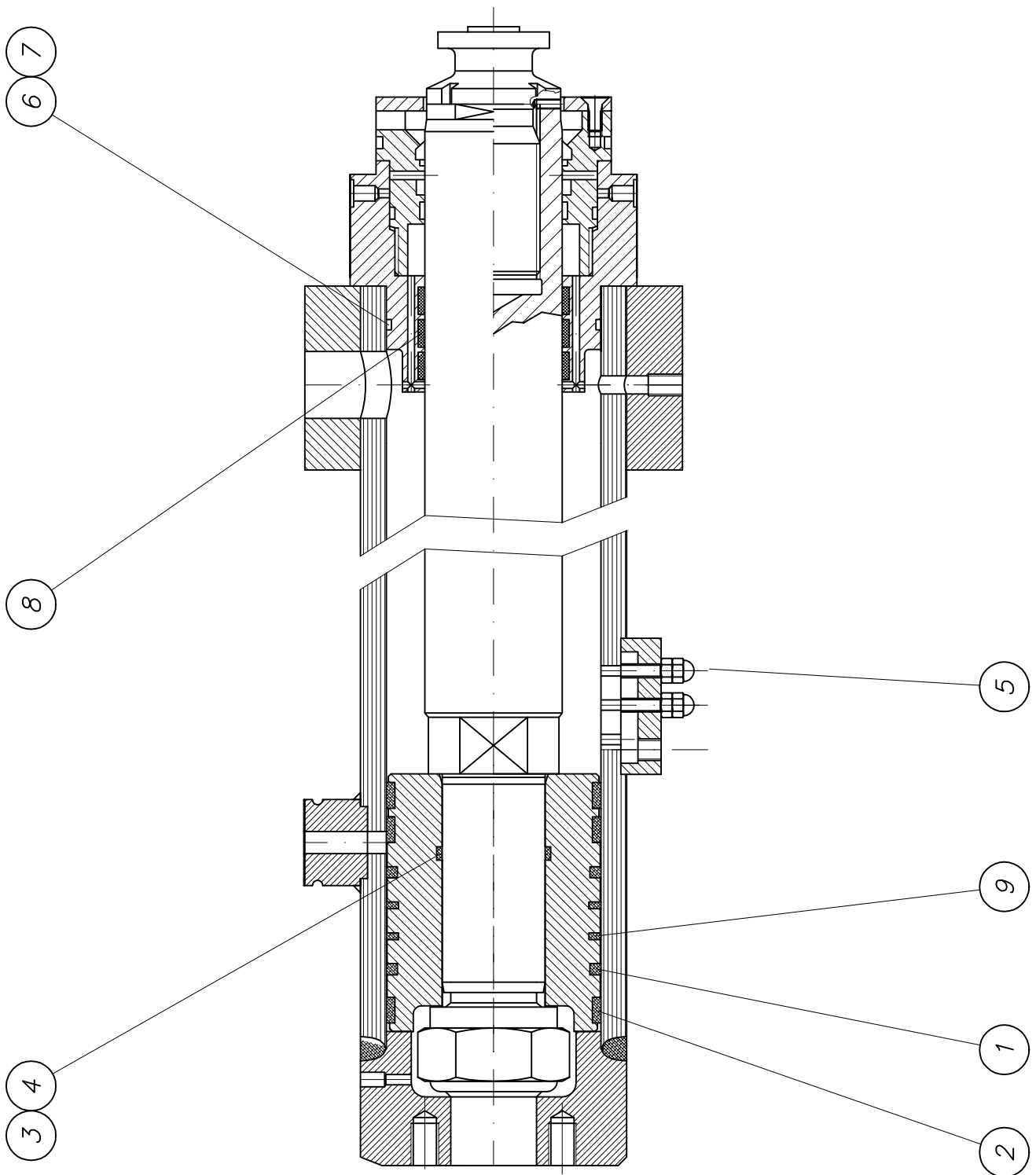



# PARTS LIST

part list	description	created	index	valid from	valid to	
WAI106354	sealing set for drive cylinder 125/80	06.09.00 hbk				
pos	description stock	ident-no dimensions	DIN material	index	weigh Kg	quantity unit
1	piston ring permasel DN125	WAI100260			0,05	2,00 Stk
2	rod support for drive cylinder	WAI105738				3,00 Stk
3	back-up ring	WAI105736				2,00 Stk
4	o-ring	WAI105734				1,00 Stk
5	usit-ring 8.7-14-1	WAI101269				8,00 Stk
6	back-up ring	WAI105951				1,00 Stk
7	o-ring	WAI105952				1,00 Stk
8	rod support for drive cylinder	WAI105730				3,00 Stk
9	piston ring	WAI106357				2,00 Stk

*Schiebersystem kpl.*  
*s-valve system cpl.*

**B 17 4 155**

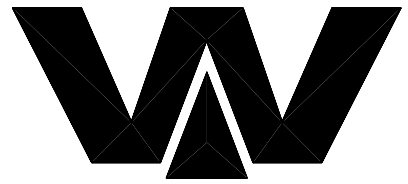

Waitzinger  
Baumaschinen GmbH

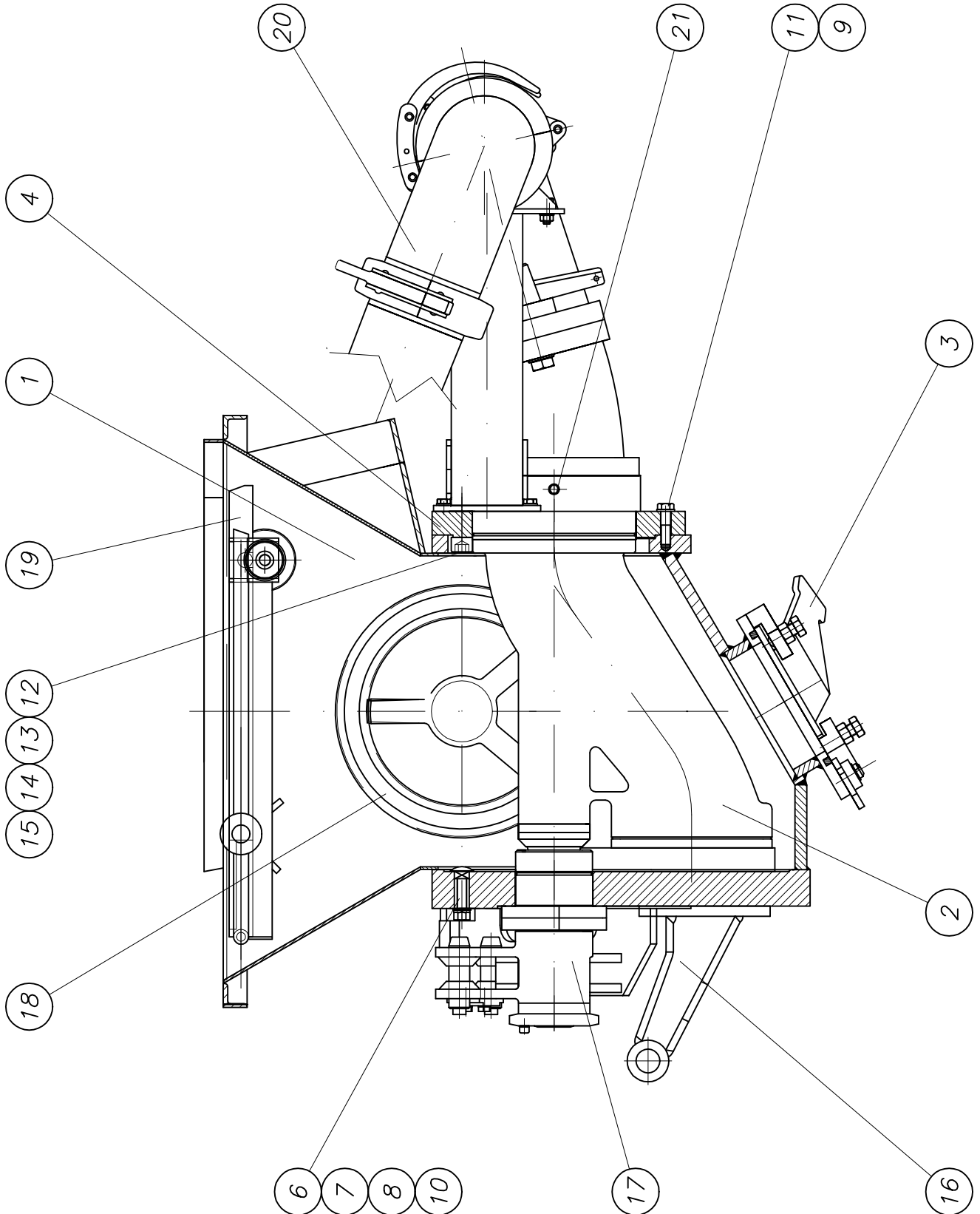





## PARTS LIST

part list	description	created	index	valid from	valid to	
B174155	s-valve system cpl.	17.09.03 HF				
pos	description stock	ident-no dimensions	DIN material	index	weigh Kg	quantity unit
1	s-valve housing with light panel own parts list	B174139				1,00 Stk
2	s-valve system cpl. own parts list	B174090		d 02.04.03		1,00 Stk
3	cleaning hole assembly own parts list	B173085				1,00 Stk
4	rear plate	B174077 Blech45x575x440	1543/EN10029 St52-3	a 04.08.98	40,00	1,00 Stk
6	cup square neck bolt M 16 x 80	WAI105047				2,00 Stk
7	washer 17, DIN 125	WAI102893				2,00 Stk
8	spring washer A16	WAI102072			0,01	2,00 Stk
9	hexagon bolt M 16 x 60	WAI103282			0,12	9,00 Stk
10	nut M16 DIN 934	WAI101555				2,00 Stk
11	conical spring washer	WAI100506				9,00 Stk
12	cheese head screw M 24 x 80	WAI102853				2,00 Stk
13	spring washer	WAI101786			0,00	2,00 Stk
14	washer 25, DIN 125	WAI103298				2,00 Stk
15	nut M24 DIN 934	WAI102851				2,00 Stk
16	pump support cpl. for hopper own parts list	B114216		a 16.06.04		1,00 Stk
17	shift drive system cpl. own parts list	B174030		b 31.05.05		1,00 Stk
18	agitator with drive own parts list	B254120		b 05.10.99		1,00 Stk
19	grid cpl. own parts list	B224065				1,00 Stk
20	conveying pipe line cpl. HP9420/12523 own parts list	B194140		b 29.06.05		1,00 Stk
21	lubrication system complete own parts list	B183007		c 14.10.03		1,00 Stk

S-Rohr kpl.

s-valve cpl.

B 17 4 090d

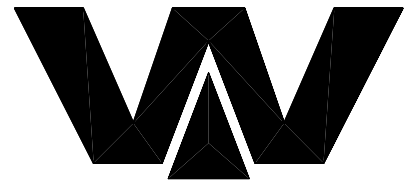

Waitzinger  
Baumaschinen GmbH

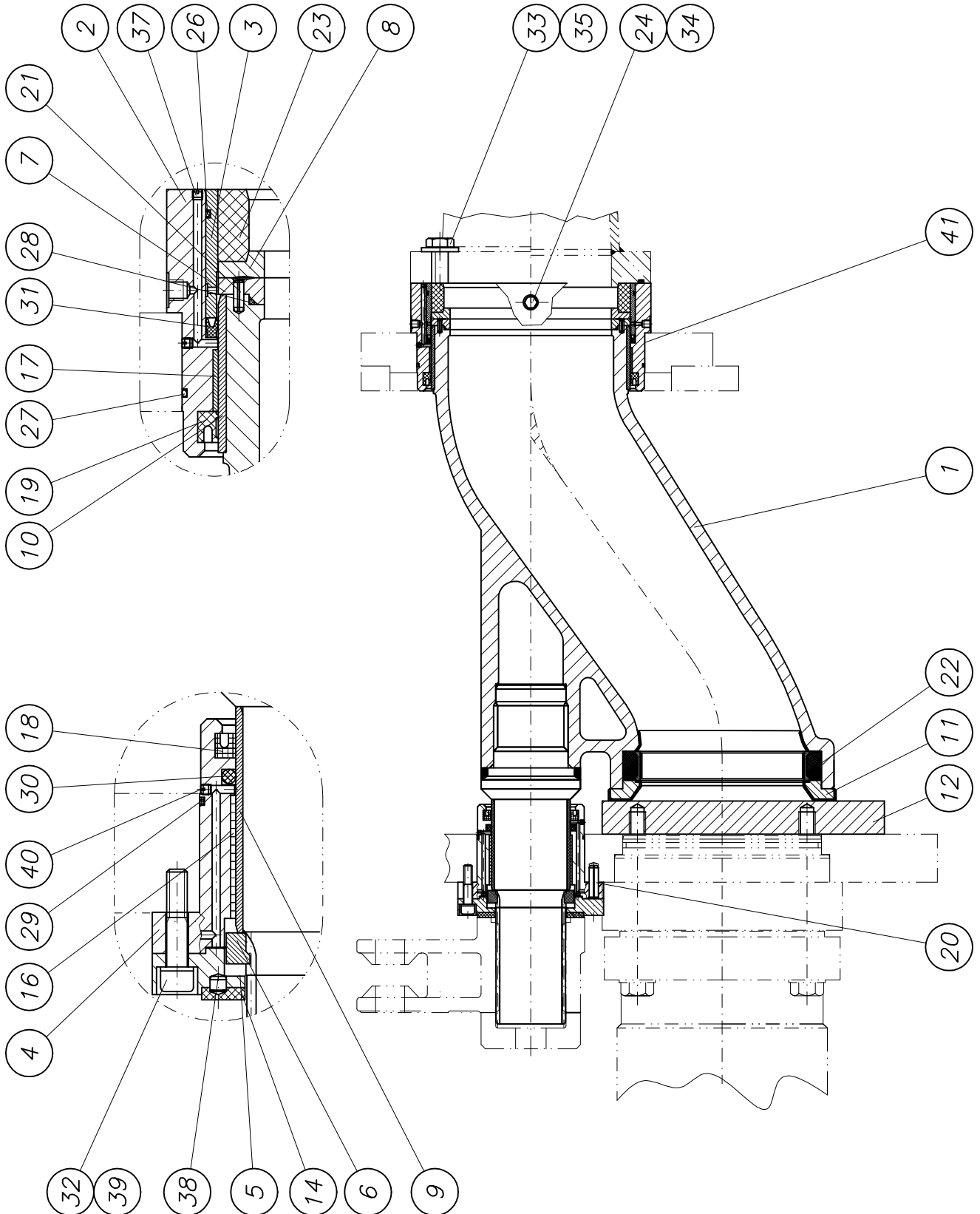



## PARTS LIST

part list	description	created	index	valid from	valid to	
B174090	s-valve system cpl.	26.01.98 Mi	d	02.04.03		
pos	description stock	ident-no dimensions	DIN material	index	weighth Kg	quantity unit
1	s-valve cpl. DN 200 w/o ring appendix own parts list	B174089				1,00 Stk
2	bearing housing big (processing) own parts list	B174022		a 23.05.05	18,50	1,00 Stk
3	distance ring	B174023 Rohr 273x20x65	2448 St37	a 16.06.04	2,20	1,00 Stk
4	bearing housing small	B174024 Rd 180x120	1013 St52-3	a 09.01.97	5,05	1,00 Stk
5	flange	B174025 Rd 180x25	1013 St52-3	b 17.06.04		1,00 Stk
6	profile	B174026 Rd 110x21	GG-25	a 06.06.97	2,50	1,00 Stk
7	sliding ring DN 200 S-valveside	B174027 Modell WAI 1004	G-X CrMo 15 3		1,10	1,00 Stk
8	slide ring DN 200 clampringside	B174028			1,10	1,00 Stk
9	wear bushing small	B172105 Rohr 101.6x8x11	2448 StE690	b 30.07.99	0,80	1,00 Stk
10	wear bushing big	B172107 Rohr 244.5x15.2	2458 StE 690	c 30.07.99	1,80	1,00 Stk
11	wear ring DN 200	B174087 BI 30xd270	1543/EN10029 St52-3		4,30	1,00 Stk
12	wear plate DN 215	B174091 BI 40x350x590	1543/EN10029 St52-3	a 05.08.98	31,00	1,00 Stk
14	axial bearing washer	B173012	Orkot TLG	a 17.06.04		1,00 Stk
16	bushing 95x100x60 BO9	WAI100237			0,39	1,00 Stk
17	bushing 240x245x30 BO 9	WAI100236			0,48	1,00 Stk
18	groove ring 95x115x12 own parts list	B173077			0,04	1,00 Stk
19	groove ring 240x260x15 own parts list	B173078			0,04	1,00 Stk
20	clamping sleeve 12 x 40	WAI103076				1,00 Stk
21	clamping sleeve 5 x 15	WAI103077				2,00 Stk
22	tension ring	WAI103378			0,60	1,00 Stk
23	tension ring hard	WAI100262			0,52	1,00 Stk
24	usit-ring 8.7-14-1	WAI101269				1,00 Stk



## PARTS LIST

part list	description	created	index	valid from	valid to	
B174090	s-valve system cpl.	26.01.98 Mi	d	02.04.03		
pos	description stock	ident-no dimensions	DIN material	index	weighth Kg	quantity unit
26	O-ring 244 x 3	WAI103365				1,00 Stk
27	O-ring	WAI100481				1,00 Stk
28	O-ring 205x3	WAI100625				1,00 Stk
29	O-ring 124x3	WAI100486			0,00	1,00 Stk
30	O-ring 95x7	WAI100485			0,02	1,00 Stk
31	forseal 240	WAI103078			0,20	1,00 Stk
32	cheese head screw M12x45	WAI103151				3,00 Stk
33	hexagon bolt M20 x 120	WAI101589				4,00 Stk
34	hexagon bolt M8 x 25 DIN 933 8.8	WAI101621				1,00 Stk
35	conical spring washer	WAI102110			0,05	4,00 Stk
37	set screw	WAI100499				2,00 Stk
38	straight pin	WAI103080				1,00 Stk
39	spring washer A12	WAI103113				3,00 Stk
40	set screw	WAI102710				4,00 Stk
41	washer	B174093 Bl 1x145x290	1543/EN10029 S235J2G3			2,00 Stk

*Reinigungsklappe kpl.*  
*cleaning cover cpl.*

**B 17 3 085**

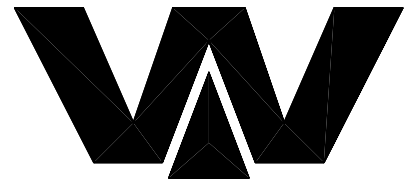

Waitzinger  
Baumaschinen GmbH

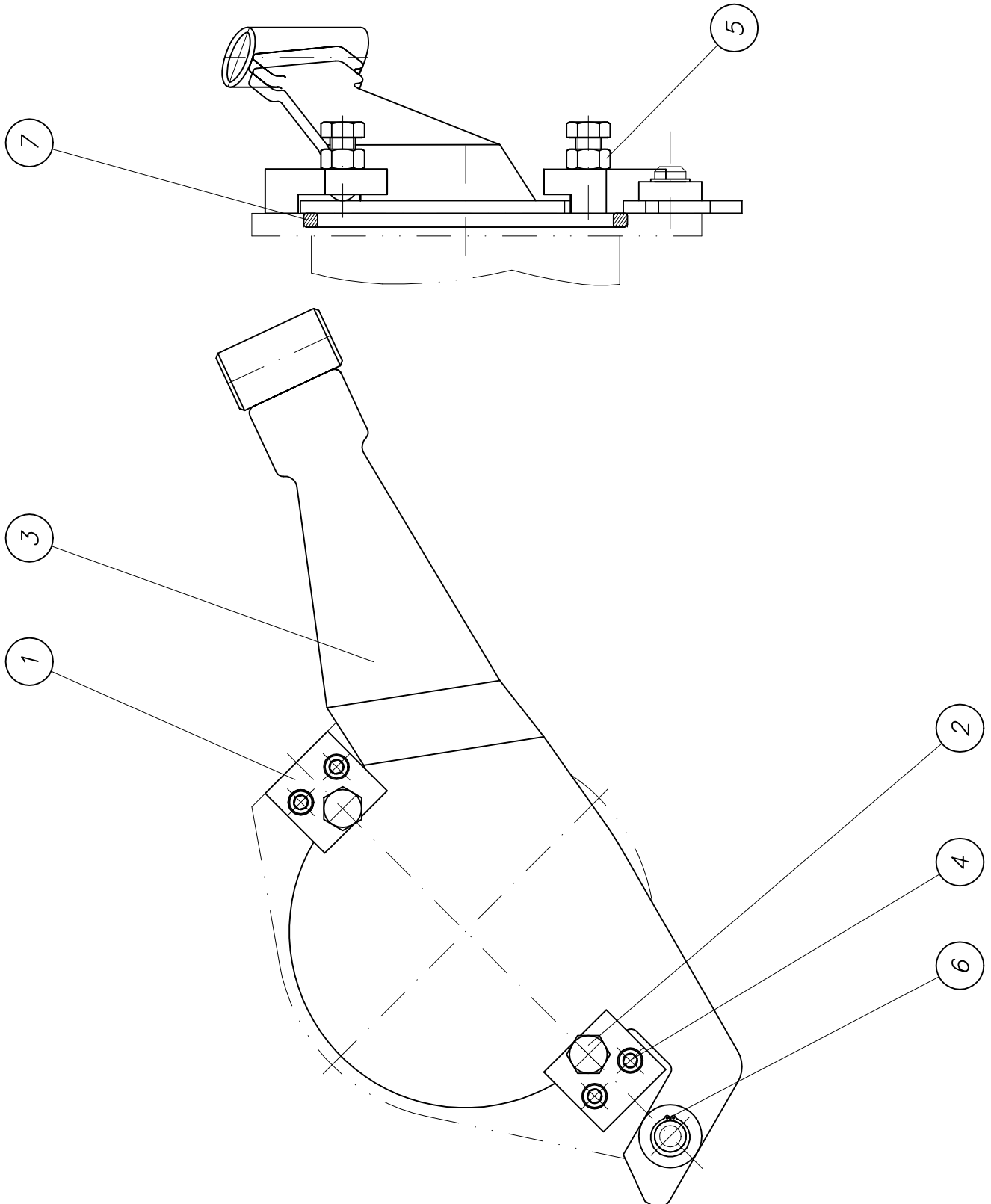



## PARTS LIST

part list	description	created	index	valid from	valid to	
B173085	cleaning hole assembly	22.10.96 JR				
pos	description stock	ident-no dimensions	DIN material	index	weighth Kg	quantity unit
1	plate	B172126 Bl 40x67x70	1543/EN10029 St52-3		0,89	2,00 Stk
2	screw M 20 (processing) own parts list	B172128 6-Kt.Schraube M	933-8.8		0,18	2,00 Stk
3	cover cpl. for cleaning cover own parts list	B172130		a 15.06.04	9,00	1,00 Stk
4	cheese head screw M 12 x 40	WAI102855				4,00 Stk
5	nut M20 DIN 934	WAI102891				2,00 Stk
6	locking ring	WAI102864				1,00 Stk
7	O-ring cord 12mm	WAI102908				0,78 Mtr

Schwenkantrieb kpl.  
tilting drive cpl.

B 17 4 030b

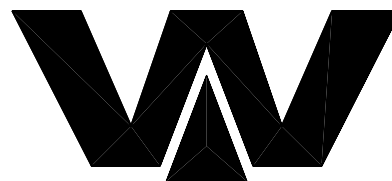

Waitzinger  
Baumaschinen GmbH

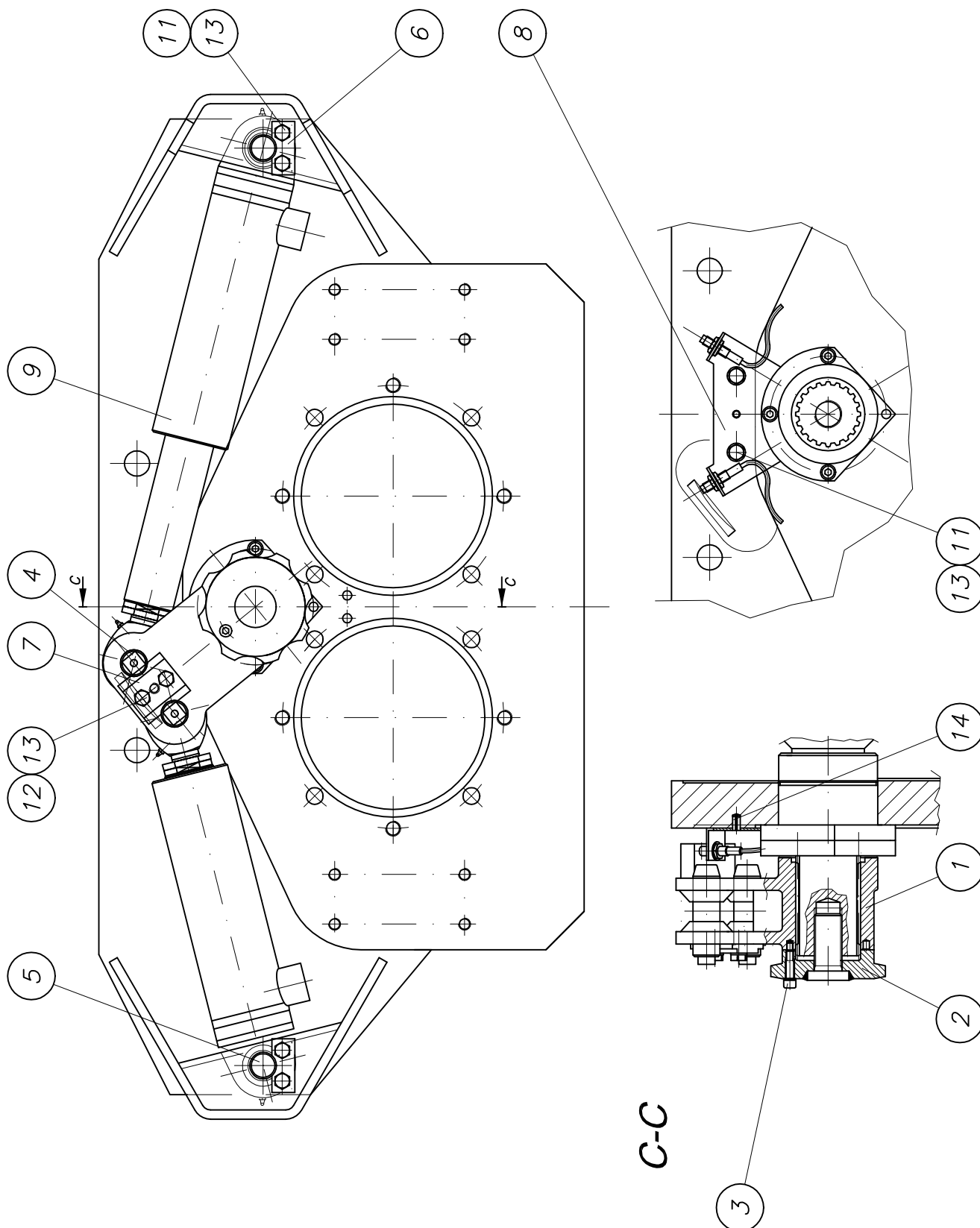



## PARTS LIST

part list	description	created	index	valid from	valid to	
B174030	shift drive system cpl. own parts list	26.06.97 HG	b	31.05.05		
pos	description stock	ident-no dimensions	DIN material	index	weighth Kg	quantity unit
1	lever arm (processing) own parts list	B174031		a 21.02.97	13,00	1,00 Stk
2	adjusting screw cpl. own parts list	B174032		a 14.07.98		1,00 Stk
3	screw M 10 x 50 (processing) own parts list	B174035				1,00 Stk
4	bolt	B173019 Rd 40x125	1013 42CrMo4V		0,83	2,00 Stk
5	bolt	B173066 Rd 40x115	1013 42CrMo4V	a 06.04.00	0,80	2,00 Stk
6	axle retainer	B173067 FI 30x6x70	1017 St52-3		0,13	2,00 Stk
7	axle retainer	B174083 BI 12x64x70	1543/EN10029 St37		0,31	1,00 Stk
8	sensor support	B174084 BI 3x212x257	1543/EN10029 St37-2		0,04	1,00 Stk
9	tilting cylinder D 65x220	WAI109491			23,00	2,00 Stk
11	hex. bolt M12 x 25 DIN 933 8.8	WAI101001			0,04	6,00 Stk
12	hex. bolt M12x30 DIN 933 8.8	WAI102107			0,04	2,00 Stk
13	conical spring washer 12 mm	WAI102877				8,00 Stk
14	clamping sleeve 10 x 20	WAI102881				1,00 Stk



*Pumpenlagerung Trichter*  
*pump support hopper*

**B 11 4 216a**



Waitzinger  
Baumaschinen GmbH

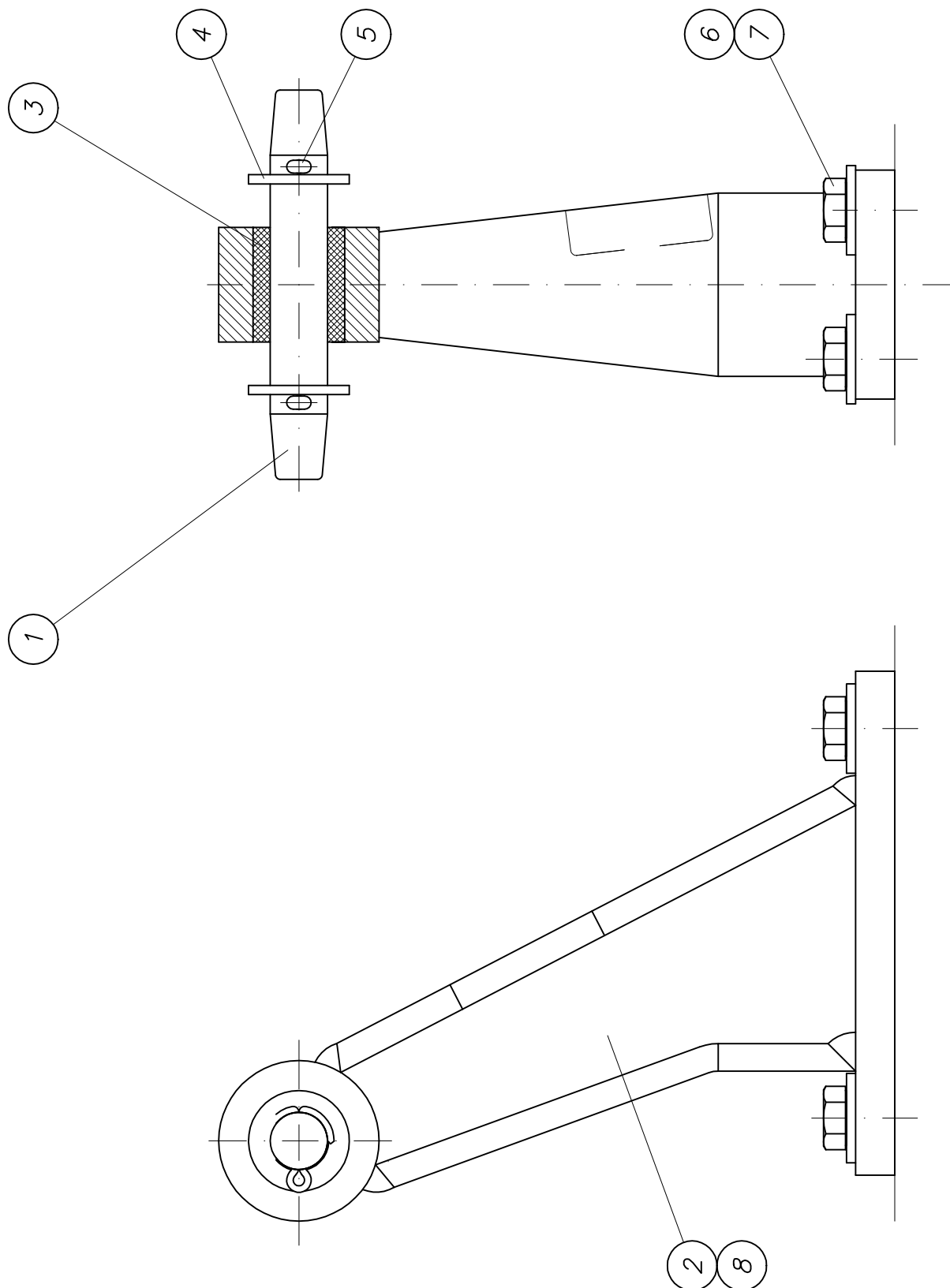



## PARTS LIST

part list	description	created	index	valid from	valid to	
B114216	pump support cpl. for hopper	16.09.03 ute	a	16.06.04		
pos	description stock	ident-no dimensions	DIN material	index	weighth Kg	quantity unit
1	bolt	B113021 Rd 30x175	1013 42CrMo4V	a 13.02.02	0,65	2,00 Stk
2	bracket cpl. (processing drawing) own parts list	B114205			8,70	1,00 Stk
3	rubber buffer 40 x 25 x 50	WAI102489			0,21	2,00 Stk
4	washer 26, DIN 126	WAI103411				4,00 Stk
5	pin	WAI100940				4,00 Stk
6	hexagon bolt M 16 x 50	WAI103278				8,00 Stk
7	conical spring washer	WAI100506				8,00 Stk
8	bracket cpl. (processing drawing) own parts list	B114206			8,70	1,00 Stk

*Schmieranlage kpl*  
*lubrication system cpl.*

*B 18 3 007c*

1

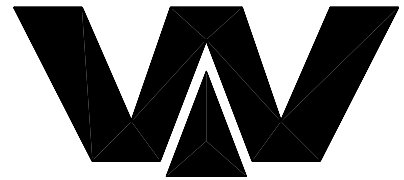

Waitzinger  
Baumaschinen GmbH

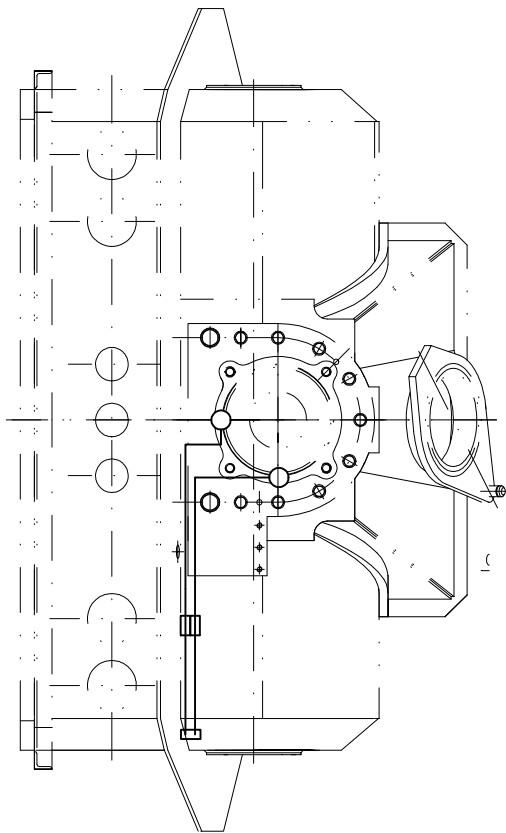
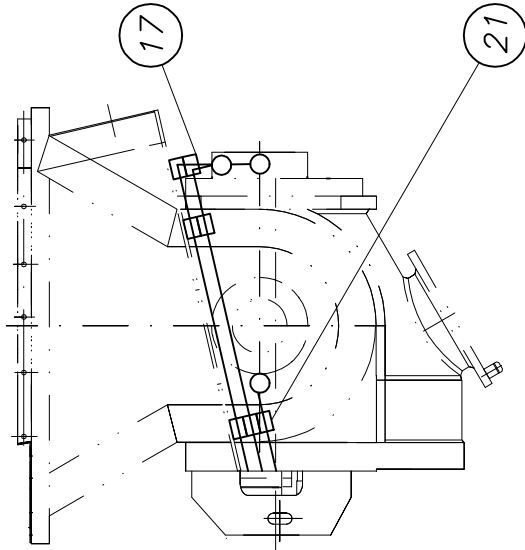

Ansicht Z

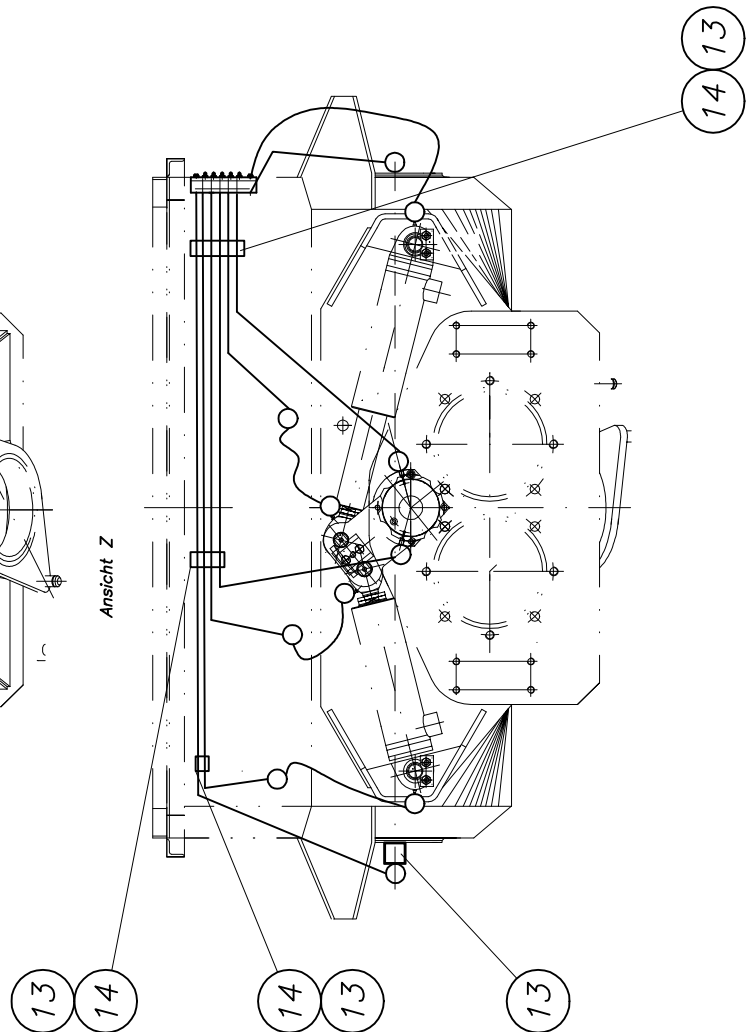

*Schmieranlage kpl*  
*lubrication system cpl.*

**B 18 3 007c**

**2**

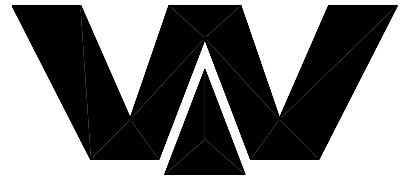

Waitzinger  
 Baumaschinen GmbH

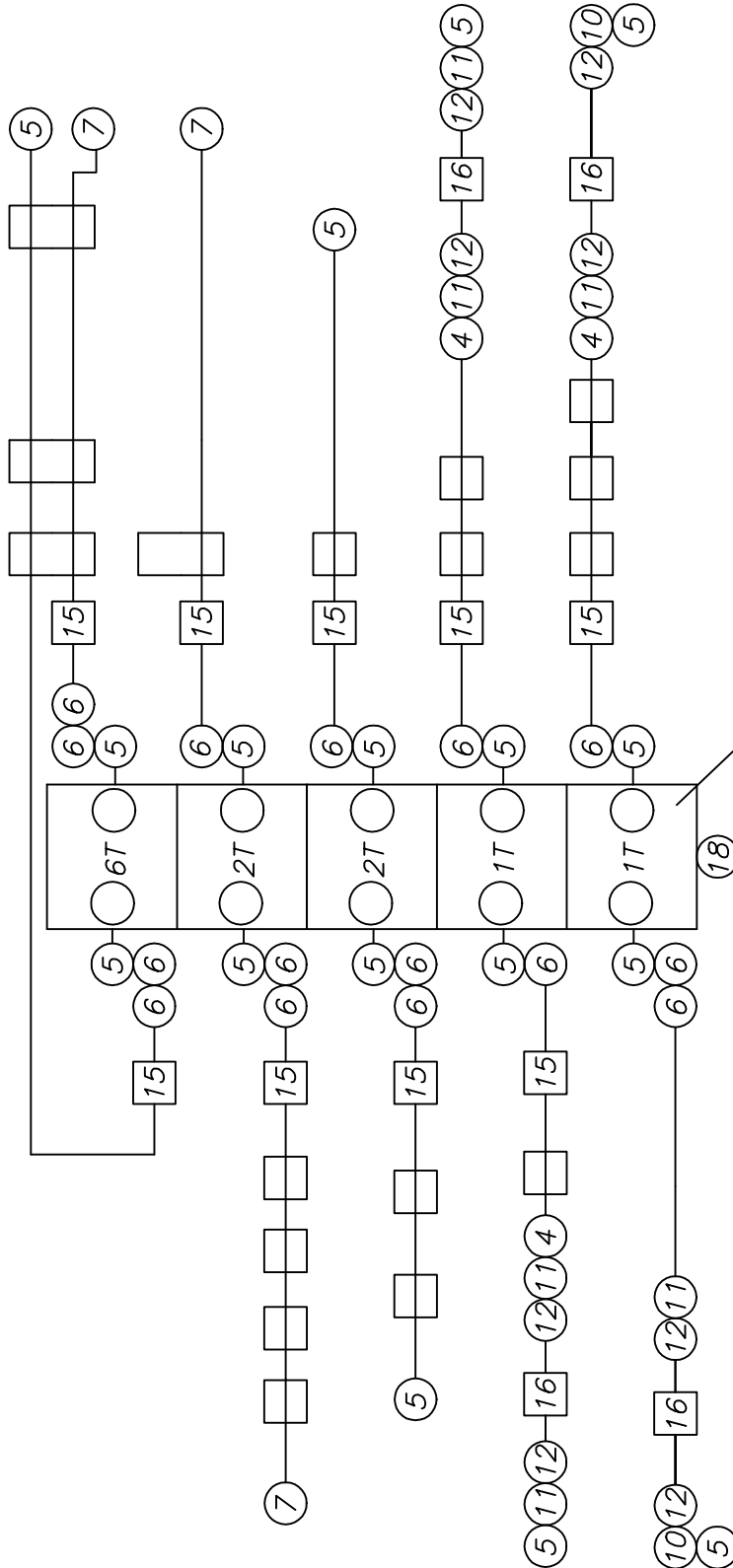



## PARTS LIST

part list	description	created	index	valid from	valid to	
B183007	lubrication system complete	18.01.99 Mi	c	14.10.03		
pos	description stock	ident-no dimensions	DIN material	index	weighth Kg	quantity unit
1	lubrication distributor complete (10) own parts list	WAI102602			0,01	1,00 Stk
2	hexagon bolt M 6 x 50	WAI104338				3,00 Stk
3	locking nut	WAI102131			0,00	3,00 Stk
4	straight couplings L6	WAI105282				3,00 Stk
5	straight male stud couplings L6M	WAI100546			0,03	17,00 Stk
6	adjustable elbow bodies L6	WAI102664			0,02	15,00 Stk
7	throttlefree banjo elbows L6M	WAI102284				3,00 Stk
10	threaded sleeve, 90 degrees	WAI102643			0,02	2,00 Stk
11	hose connecting piece, DN6, short	WAI100253			0,01	6,00 Stk
12	threaded sleeve	WAI100254			0,01	8,00 Stk
13	pipe clip 6 mm,	WAI105144			0,07	13,00 Stk
14	Tee-Nut for pipe clamps	WAI105151			0,07	24,00 Stk
15	set of pipes for greasing system	WAI105416				1,00 Stk
16	plastic pipe 8.4 x 2.1	WAI100255			0,05	3,00 Mtr
17	pipe clip 6 mm,	WAI108327			0,07	4,00 Stk
18	straight male stud couplings L6M14 x 1,5	WAI102665			0,04	1,00 Stk
20	cable tie 200x3.6, black	WAI103137				10,00 Stk
21	hexagon screw M 6 x 60 DIN 931 8.8	WAI104065				1,00 Stk
22	washer 6.4	WAI101627				3,00 Stk

*Schmierverteiler kpl.*  
*lubrication distributor cpl.*

*WAI 102602*



Waitzinger  
Baumaschinen GmbH

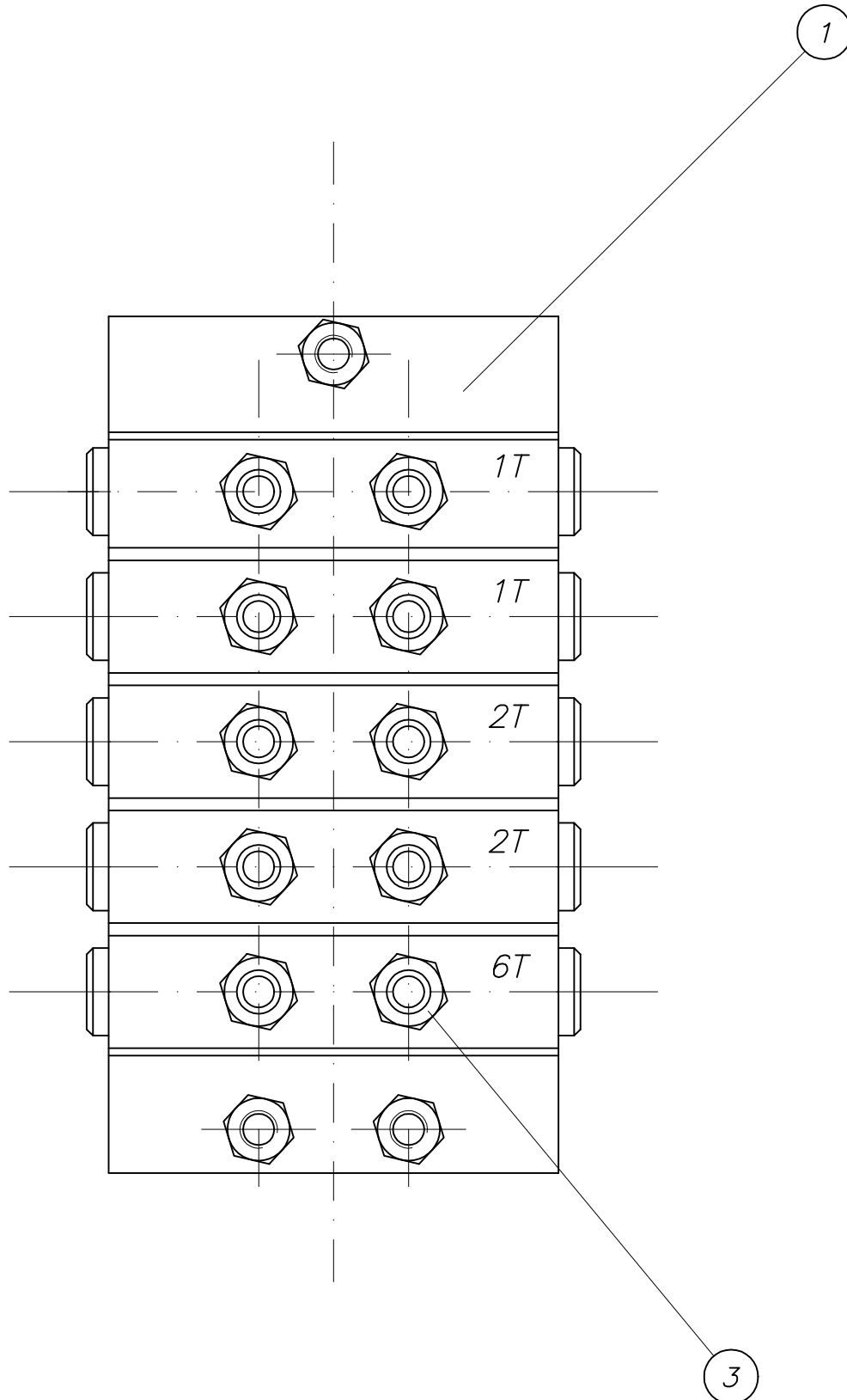



## PARTS LIST

<b>part list</b>	<b>description</b>	<b>created</b>	<b>index</b>	<b>valid from</b>	<b>valid to</b>	
WAI102602	lubrication distributor complete (10)	21.03.96 HG		21.03.96		
<b>pos</b>	<b>description stock</b>	<b>ident-no dimensions</b>	<b>DIN material</b>	<b>index</b>	<b>weigh Kg</b>	<b>quantity unit</b>
1	distributor VPM 5 own parts list	WAI102585			2,40	1,00 Stk
3	grease nipple	WAI100303			0,19	10,00 Stk

*Progressivverteiler  
distributor*

*WAI 102585*

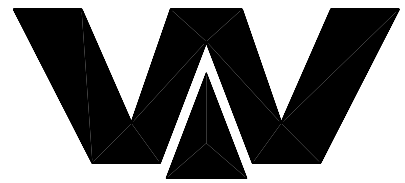

*Waitzinger  
Baumaschinen GmbH*

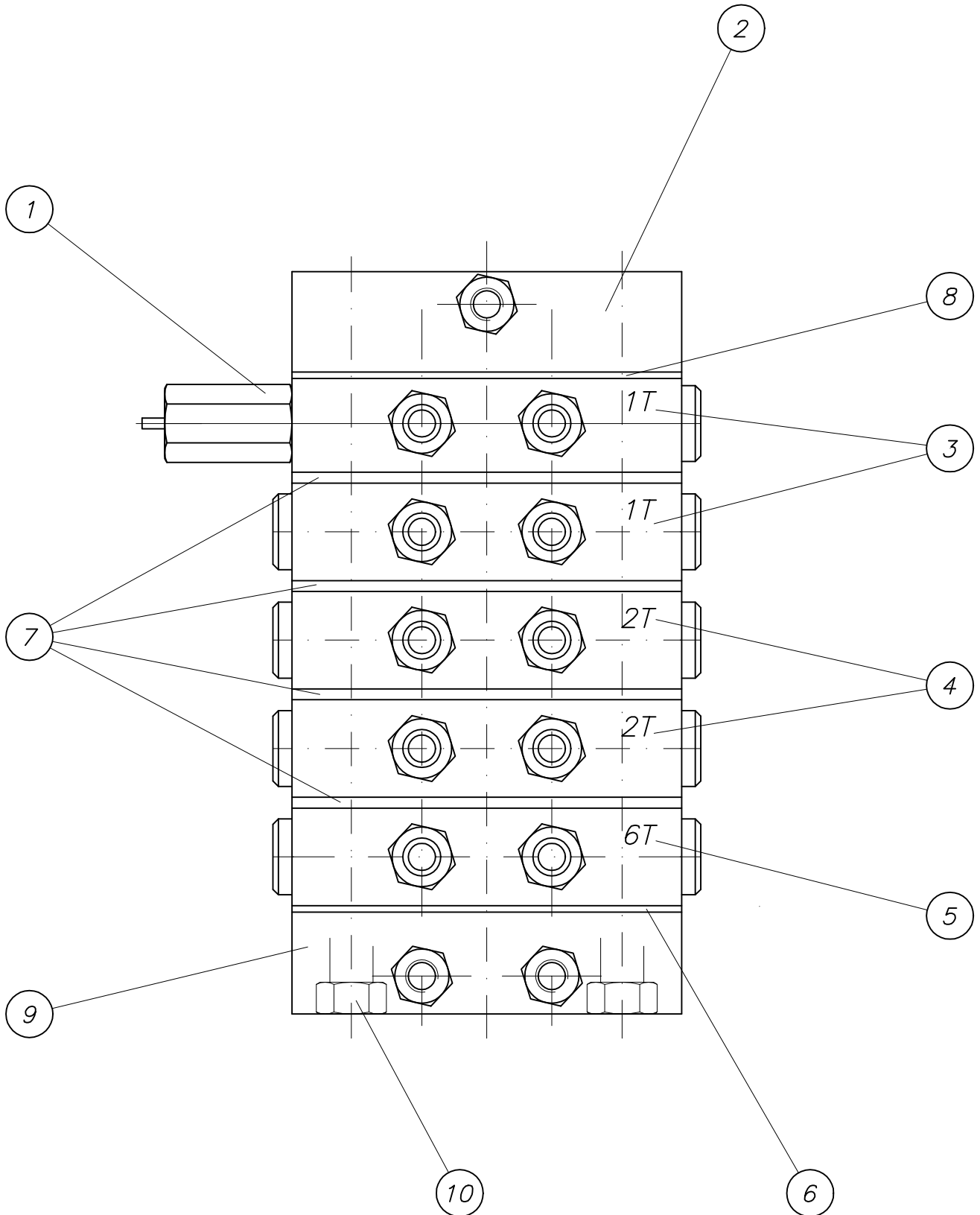





## PARTS LIST

part list	description	created	index	valid from	valid to	
WAI102585	distributor VPM 5	31.08.99 Mi				
pos	description stock	ident-no dimensions	DIN material	index	weigh Kg	quantity unit
1	cycle indicator	WAI102586				1,00 Stk
2	endplate	WAI105757				1,00 Stk
3	distributor plate	WAI105758				2,00 Stk
4	distributor plate	WAI105759				2,00 Stk
5	distributor plate	WAI105760				1,00 Stk
6	input modul	WAI105761				1,00 Stk
7	distance modul	WAI105762				4,00 Stk
8	end modul	WAI105763				1,00 Stk
9	input plate	WAI105764				1,00 Stk
10	tension rod	WAI105765				2,00 Stk

Förderleitung kpl.  
conveying pipe line cpl.

B 19 4 140b

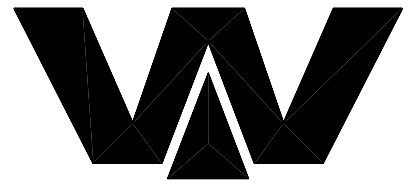

Waitzinger  
Baumaschinen GmbH

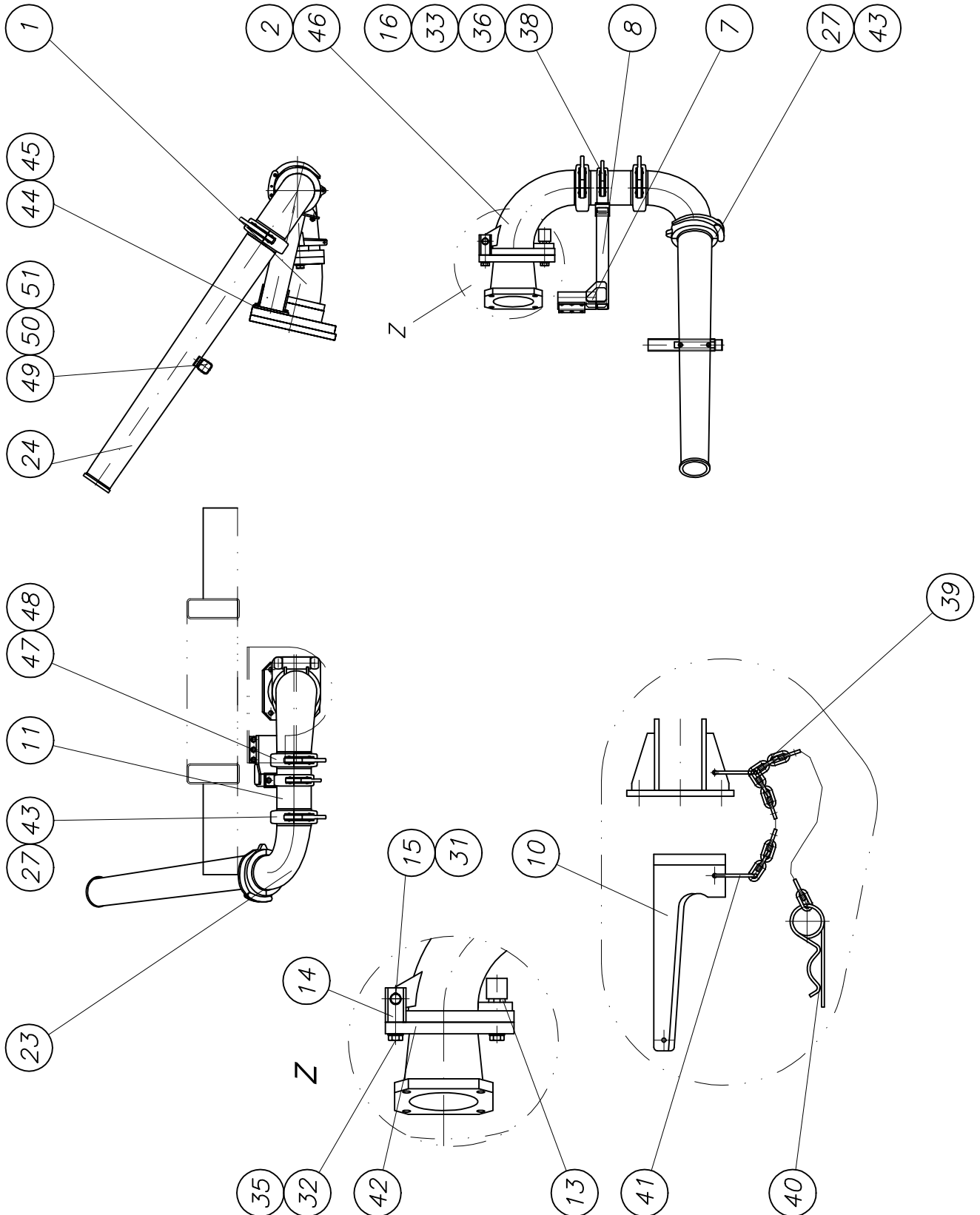



## PARTS LIST

part list	description	created	index	valid from	valid to	
B194140	conveying pipe line cpl. HP9420/12523	10.03.03 ek	b	29.06.05		
pos	description stock	ident-no dimensions	DIN material	index	weigh Kg	quantity unit
1	reducer DN 200-180 own parts list	B191010		a 06.03.97	38,00	1,00 Stk
2	reducer elbow DN 180-150 own parts list	B191015		b 17.05.99	41,50	1,00 Stk
7	bracket own parts list	B194033		a 25.09.97	5,40	1,00 Stk
8	strut cpl. own parts list	B194037		a 19.04.02	8,20	1,00 Stk
10	locking wedge complete own parts list	B194046			1,85	1,00 Stk
11	conveying pipe cpl. own parts list	B194062			12,85	1,00 Stk
13	locking bolt	B194045 Rundstahl 50x12	1013 St52-3		1,05	1,00 Stk
14	hinge	B194049 Rundstahl d60x1	1013 St52-3		1,70	2,00 Stk
15	bolt	B194050 Rundstahl d30h9	671 St52-3	a 12.02.98		1,00 Stk
16	snap coupling 5 1/2" own parts list	B194053				1,00 Stk
23	bend DN 150	WAI100690				1,00 Stk
24	reducer DN 150-125	WAI102041				1,00 Stk
27	clamp coupling 6"	WAI101779				2,00 Stk
31	snap ring	WAI100694			0,00	2,00 Stk
32	hexagon bolt M 24 x 65	WAI102848				3,00 Stk
33	hexagon bolt M16 x 40	WAI101634				4,00 Stk
35	washer HV25	WAI102331				3,00 Stk
36	washer 17, DIN 125	WAI102893				4,00 Stk
38	nut M16 DIN 934	WAI101555				4,00 Stk
39	chain 4mm	WAI103732				1,00 mtr
40	cotter pin	WAI101266			0,06	1,00 Stk



## PARTS LIST

part list	description	created	index	valid from	valid to	
B194140	conveying pipe line cpl. HP9420/12523	10.03.03 ek	b	29.06.05		
pos	description stock	ident-no dimensions	DIN material	index	weigh Kg	quantity unit
41	key ring	WAI104636				2,00 Stk
42	O-ring	WAI104025				1,00 Stk
43	O-ring 159 x 11	WAI108307			0,05	2,00 Stk
44	cheese head screw	WAI101792				6,00 Stk
45	spring washer A12	WAI103113				6,00 Stk
46	grease nipple H1 M10 X 1 DIN 71412	WAI100805			0,01	1,00 Stk
47	wedge coupling 6"	WAI105165			5,00	1,00 Stk
48	O-ring	WAI105164			0,05	1,00 Stk
49	profil cpl. own parts list	B195033		a 22.06.05	3,00	1,00 Stk
50	strip	B190019 8x30x200	Polyamid			1,00 Stk
51	sunk screw M 10 x 20	WAI104689				2,00 Stk

*Gitterrost kpl.*

*grid cpl.*

*B 22 4 065*

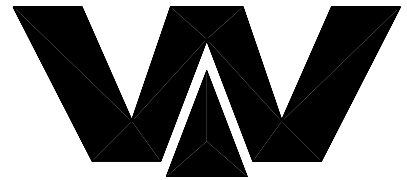

*Waitzinger  
Baumaschinen GmbH*

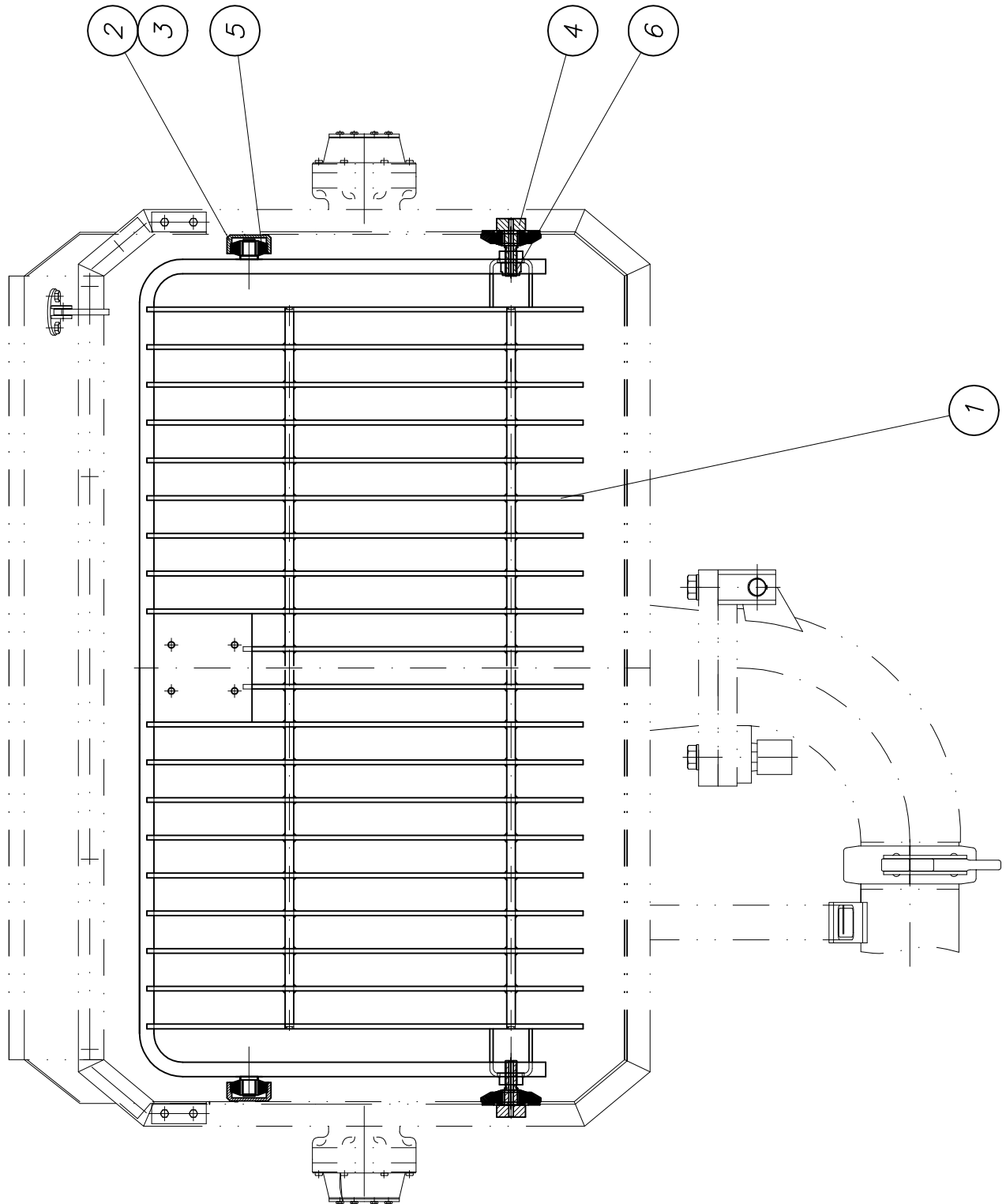



## PARTS LIST

part list	description	created	index	valid from	valid to	
B224065	grid cpl.	07.02.02 Mi				
pos	description stock	ident-no dimensions	DIN material	index	weighth Kg	quantity unit
1	grate own parts list	B224060		b 26.05.03	60,00	1,00 Stk
2	housing for grating	B223061 Rd 80x20	1013 S355J2G3		0,50	2,00 Stk
3	fixing sheet	B223057 Bl 10x32x50	1543/EN10029 St37-2		0,10	4,00 Stk
4	bolt	B225041 Rd 50x104	1013 St52-3	b 05.04.05	0,20	2,00 Stk
5	rubber buffer 65 x 22,5 x 26	WAI102490			0,17	4,00 Stk
6	nut M20 DIN 985	WAI106610				2,00 Stk

*Rührwerk mit Antrieb kpl.*  
*agitator with drive cpl.*

*B 25 4 120b*

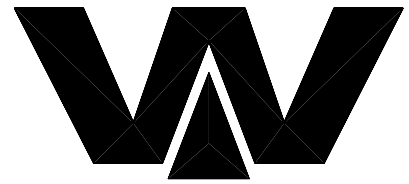

Waitzinger  
Baumaschinen GmbH

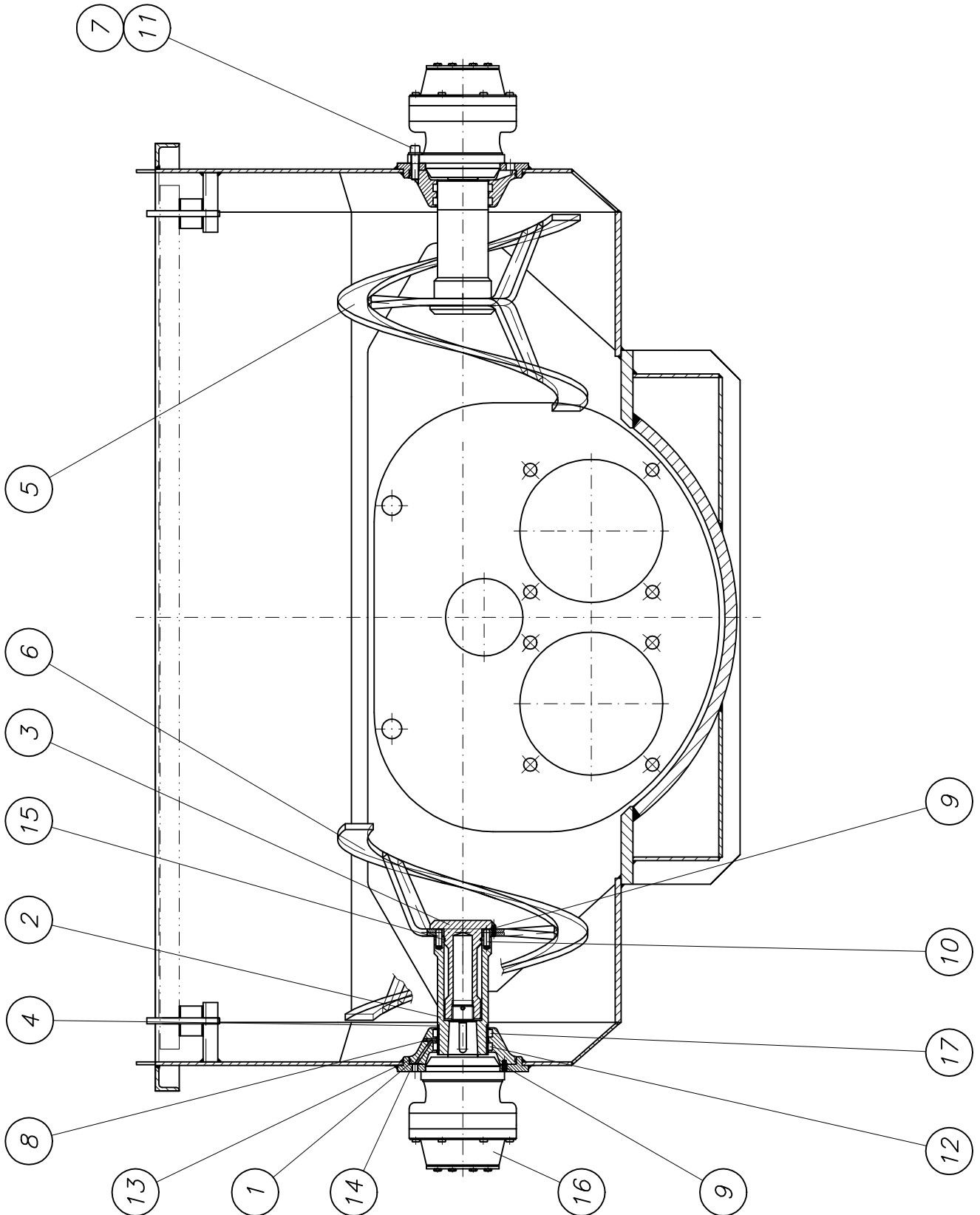



## PARTS LIST

part list	description	created	index	valid from	valid to	
B254120	agitator with drive	24.04.98 rh	b	05.10.99		
pos	description stock	ident-no dimensions	DIN material	index	weighth Kg	quantity unit
1	flange own parts list	B254101		a 23.01.97		2,00 Stk
2	shaft	B254102 Rd 100x199	1013 St52	c 02.04.03	1,50	2,00 Stk
3	nut	B254103 Rd 110x165	1013 ST52			2,00 Stk
4	wear sleeve	B254104 Rohr 88.9x8.8x5	2448 StE 690	a 01.12.97	0,49	2,00 Stk
5	agitator shaft, right own parts list	B254105		c 08.04.03	10,00	1,00 Stk
6	agitator shaft, left own parts list	B254106		c 08.04.03	10,00	1,00 Stk
7	hexagon bolt	WAI103062				8,00 Stk
8	set screw	WAI100499				2,00 Stk
9	clamping sleeve 6 x 18	WAI103106				4,00 Stk
10	straight pin 10 H 6 x 30	WAI103065				12,00 Stk
11	washer	WAI102962			0,01	8,00 Stk
12	groove ring 85-100-11.5	WAI102544			0,02	2,00 Stk
13	O-ring 174 x 3	WAI103063				2,00 Stk
14	O-ring 13 x 2	WAI103064				2,00 Stk
15	O-ring 59 x 3	WAI103249				2,00 Stk
16	hydraulic motor MCR 3D 280 own parts list	WAI101240			28,00	2,00 Stk
17	tongue ring own parts list	B253029			0,02	2,00 Stk



*Hydraulikmotor*  
*hydraulic engine*

*WAI 101240*

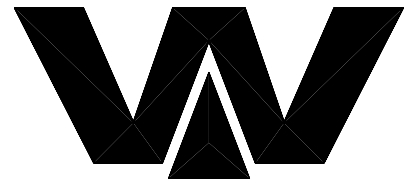

*Waitzinger*  
*Baumaschinen GmbH*

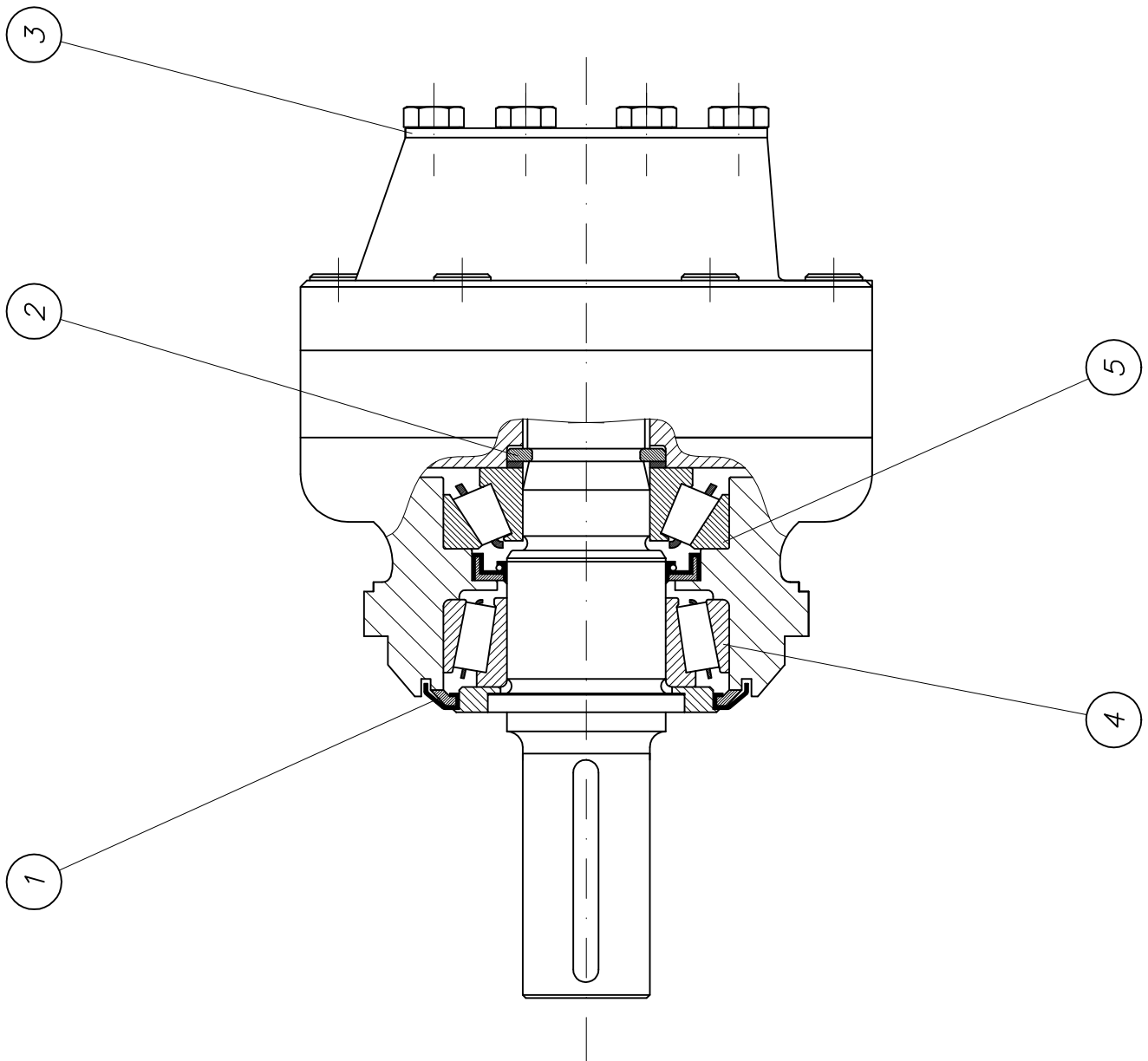



## PARTS LIST

part list	description		created	index	valid from	valid to
WAI101240	hydraulic motor MCR 3D 280		27.08.99 Mi			
pos	description stock	ident-no dimensions	DIN material	index	weigh Kg	quantity unit
1	sealing set own parts list	WAI101241			0,10	1,00 Stk
2	split ring	WAI104395				1,00 Stk
3	cover f. mcr3 hydraulic motor	WAI104755				1,00 Stk
4	roller bearing 850717	WAI105715			0,70	1,00 Stk
5	roller bearing no. 851416	WAI105716			0,80	1,00 Stk

*Schmieranlage Pumpe kpl.*

*lubrication pump cpl.*

**B 18 3 016**

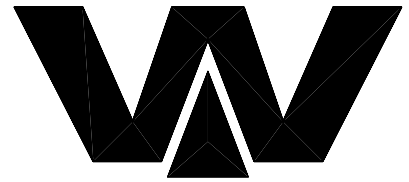

Waitzinger  
Baumaschinen GmbH

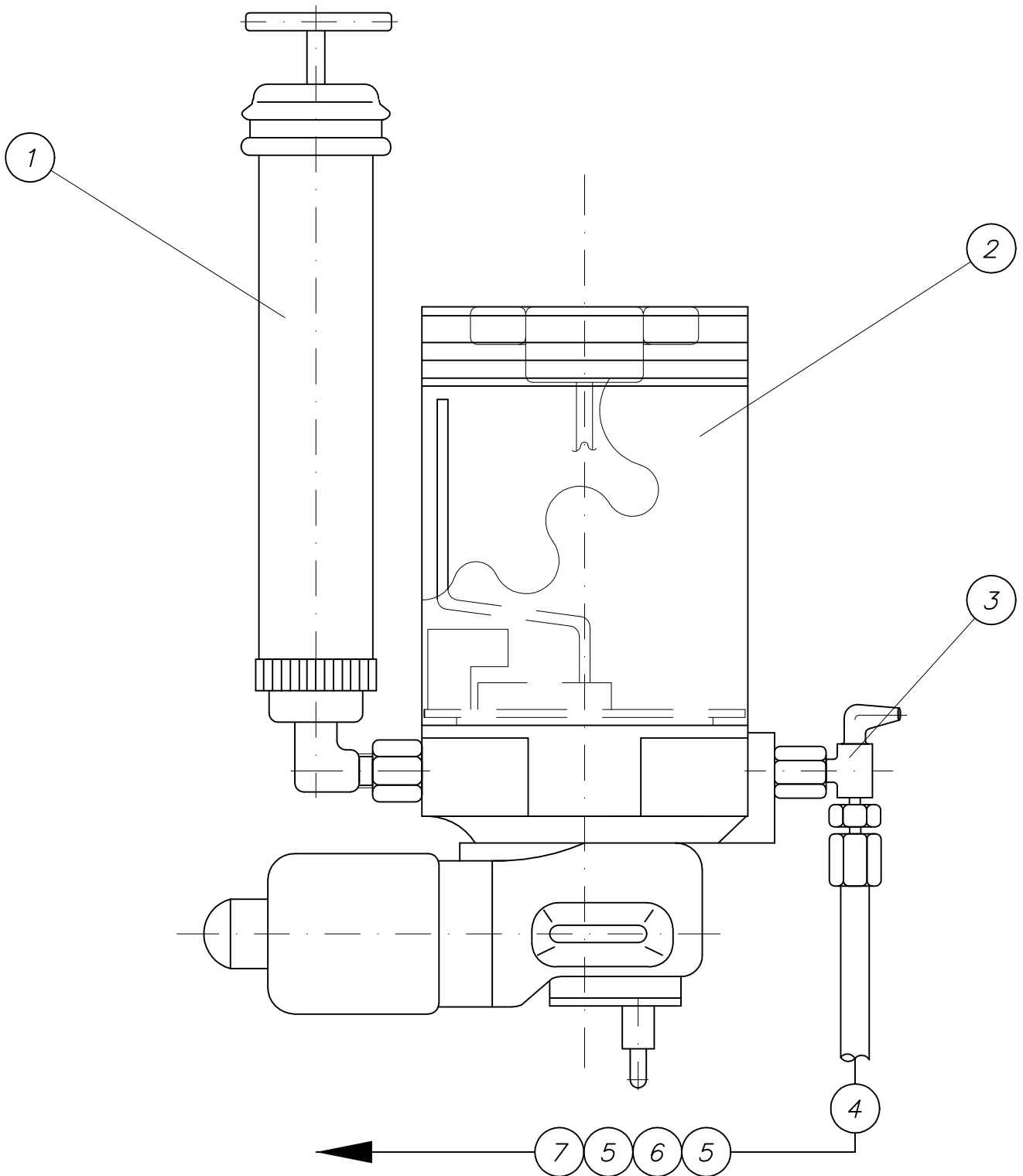



## PARTS LIST

part list	description	created	index	valid from	valid to	
B183016	lubrication pump cpl.	18.09.03 ute				
pos	description stock	ident-no dimensions	DIN material	index	weighth Kg	quantity unit
1	fill pump, hand used	WAI100297			1,16	1,00 Stk
2	pump for kit	WAI106697				1,00 Stk
3	savety valve	WAI103198			0,12	1,00 Stk
4	plastic pipe 8.4 x 2.1	WAI100255			0,05	2,00 Mtr
5	threaded sleeve	WAI100254			0,01	2,00 Stk
6	hose connecting piece, DN6, short	WAI100253			0,01	1,00 Stk
7	threaded sleeve, 90 degrees	WAI102643			0,02	1,00 Stk

Förderleitung kpl.  
conveying pipe line cpl.

B 19 8 001

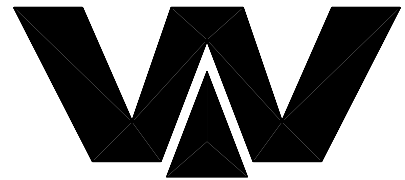

Waitzinger  
Baumaschinen GmbH

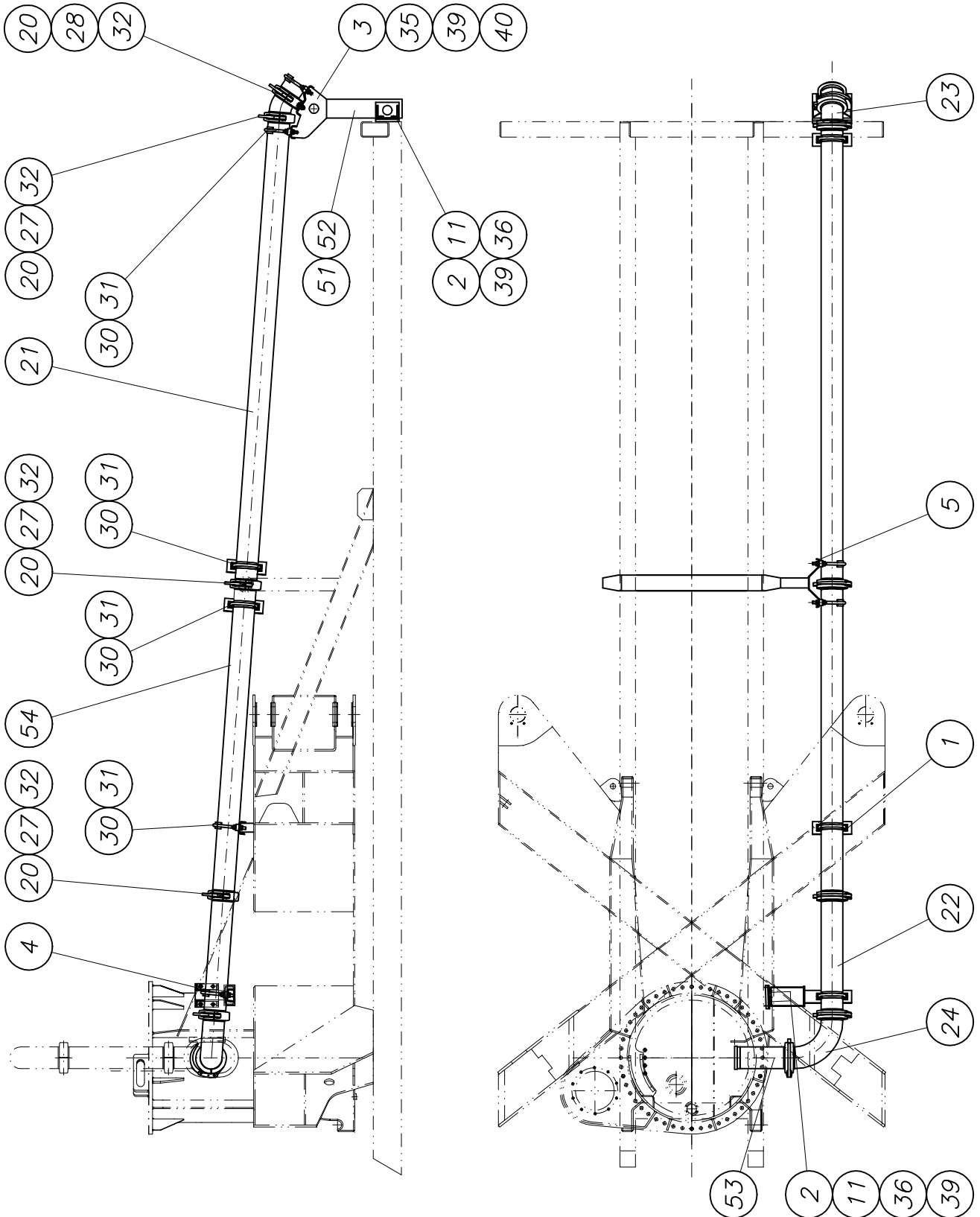



## PARTS LIST

part list	description	created	index	valid from	valid to	
B198001	conveying pipe line cpl. 36 XXT	28.04.04 ek				
pos	description stock	ident-no dimensions	DIN material	index	weigh Kg	quantity unit
1	holder own parts list	B193061			2,50	1,00 Stk
2	bracket own parts list	B194013		a 06.08.97	3,80	2,00 Stk
3	support own parts list	B194092			6,20	1,00 Stk
4	holder own parts list	B194073		b 22.07.02	7,60	1,00 Stk
5	support cpl. own parts list	B193066			3,00	1,00 Stk
11	thread plate	B194012 Bl 15x150x150	1543/EN10029 St37-2		2,60	2,00 Stk
20	sealing for coupling	WAI101267			0,20	5,00 Stk
21	pipe DN 125 x 3000	WAI100965			38,00	1,00 Stk
22	pipe DN 125 x 1500	WAI108515				1,00 Stk
23	bend DN 125 - 30 degree	WAI100963			8,00	1,00 Stk
24	concrete elbow 90 degrees	WAI100218			15,40	1,00 Stk
27	snap coupling 5 1/2"	WAI101547				4,00 Stk
28	snap coupling 5 1/2"	WAI103399				1,00 Stk
30	pipe support	WAI103448				5,00 Stk
31	bow	WAI103400				5,00 Stk
32	spring pin 8 mm	WAI102622				5,00 Stk
35	hexagon bolt M16 x 40	WAI101634				2,00 Stk
36	cheese head screw M 16 x 25	WAI103488				8,00 Stk
38	washer 17, DIN 125	WAI102893				2,00 Stk
39	spring washer A16	WAI103489			0,01	10,00 Stk
40	nut M16 DIN 934	WAI101555				2,00 Stk



## PARTS LIST

part list	description	created	index	valid from	valid to	
B198001	conveying pipe line cpl. 36 XXT	28.04.04 ek				
pos	description stock	ident-no dimensions	DIN material	index	weigh Kg	quantity unit
51	profile	B194093 MSH 120x60x5x70	59410 S235J2G3		9,10	1,00 Stk
52	cover	B084193 Bl 4x52x112	1543/EN10029 S355J2G3		0,20	2,00 Stk
53	pipe DN 125 x 350	WAI103445				1,00 Stk
54	pipe DN 125 x 2000	WAI101780			28,00	1,00 Stk

*Spritzschutz kpl.*  
*splash board cpl.*

**B 22 4 006**

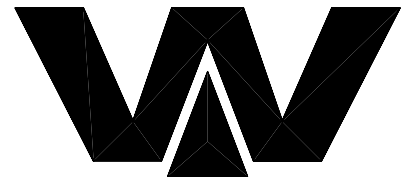

Waitzinger  
Baumaschinen GmbH

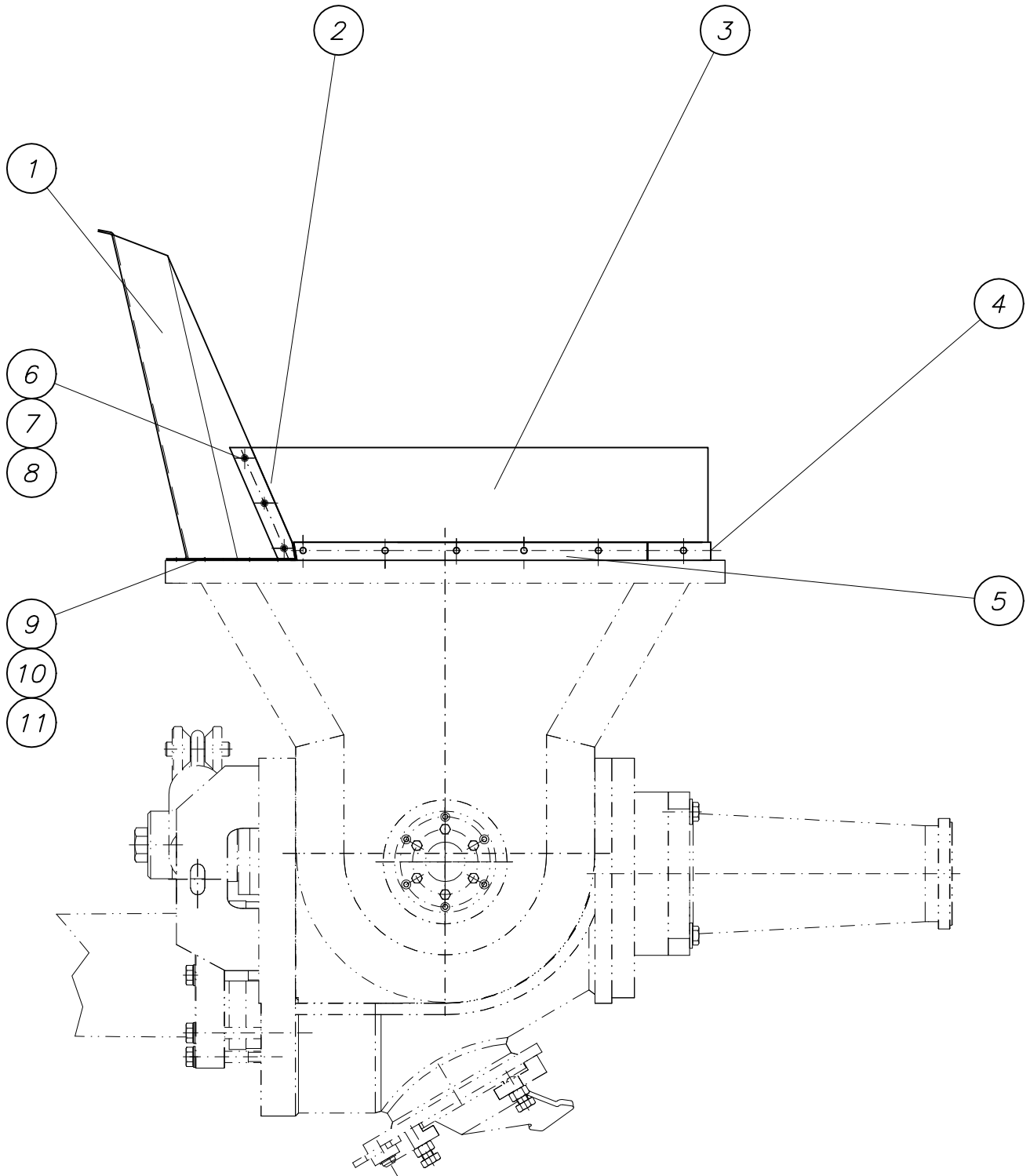





## PARTS LIST

part list	description	created	index	valid from	valid to	
B224006	splash board trailer 13 degrees	16.10.97 BW				
pos	description stock	ident-no dimensions	DIN material	index	weigh Kg	quantity unit
1	splash board	B224011 Bl 3x691x1773	1543/EN10029 St37-2	c 29.01.02	25,10	1,00 Stk
2	clamping strip	B224012 Fl 35x5x227	1017 St37-2	a 30.04.97		2,00 Stk
3	rubber apron	B224013 Gummi 10x200x31		a 25.02.00		1,00 Stk
4	strip side	B224015 Fl 30x5x755	1017 St37-2	a 24.07.00	0,85	2,00 Stk
5	strip back side	B224014 Fl 30x5x1355	1017 St37-2		1,50	1,00 Stk
6	cap screw	WAI103579				28,00 Stk
7	cap nut M6	WAI101848				28,00 Stk
8	washer 6.4	WAI101627				28,00 Stk
9	hexagon bolt M8 x 25 DIN 933 8.8	WAI101621				11,00 Stk
10	stop nut M8 DIN985 8. VERZ.	WAI102111			5,00	11,00 Stk
11	washer 8.4	WAI101625				11,00 Stk

*Rütteleinrichtung kpl.*  
*vibrating equipment cpl.*

*B 28 5 001*

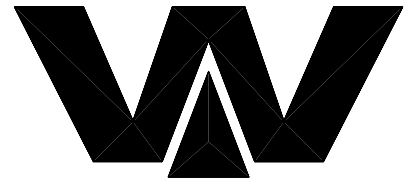

*Waitzinger*  
*Baumaschinen GmbH*

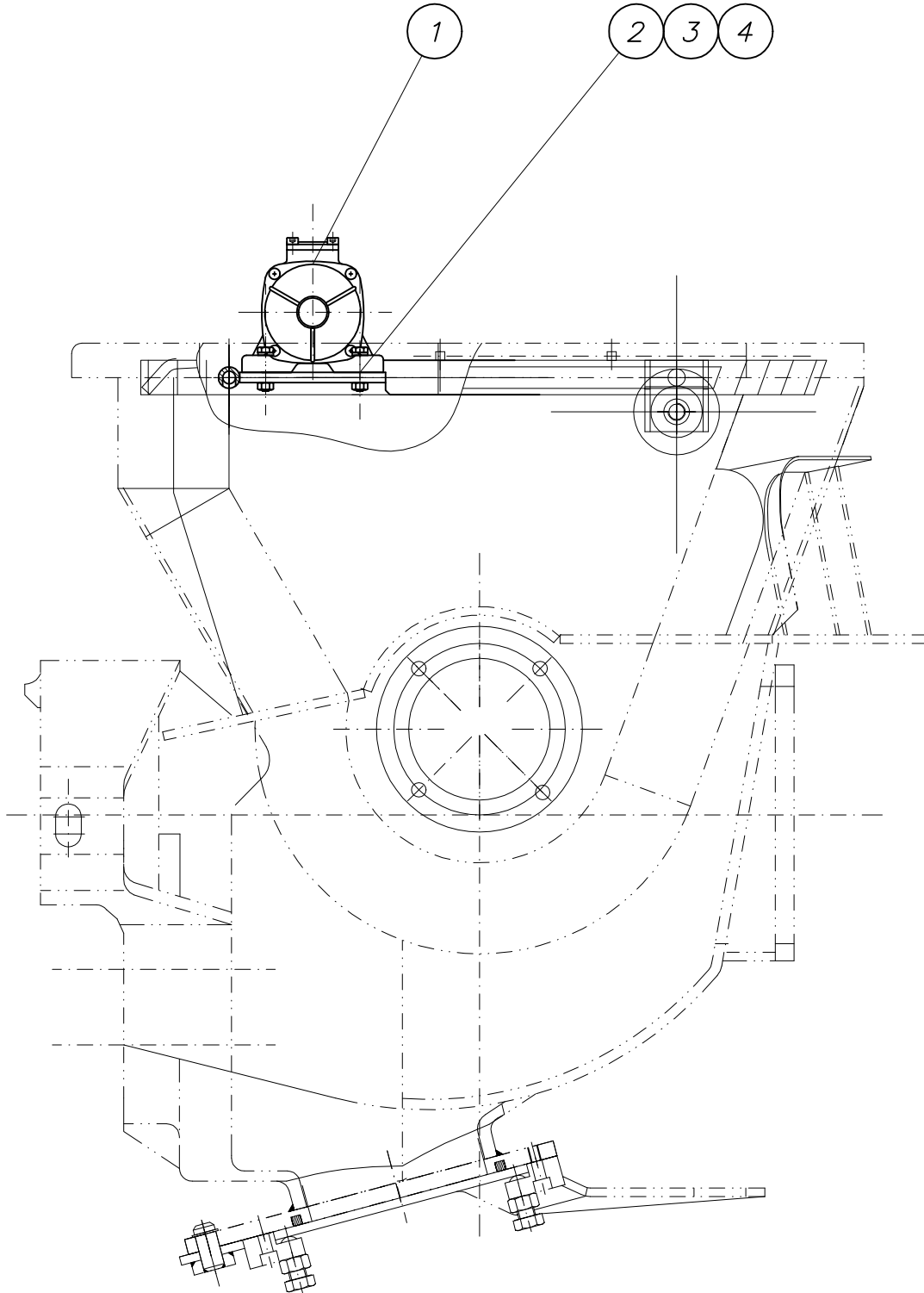



## PARTS LIST

part list	description	created	index	valid from	valid to	
B285001	vibrating equipment	20.03.01 Mi				
pos	description stock	ident-no dimensions	DIN material	index	weighth Kg	quantity unit
1	vibrator own parts list	WAI105646			6,75	1,00 Stk
2	hexagon bolt	WAI102105			0,03	4,00 Stk
3	spring washer A10	WAI102070			0,00	4,00 Stk
4	hex. nut M10 DIN985 8.	WAI102125			0,01	4,00 Stk

*Übersicht B 30 - B 39*  
*over view B 30 - B 39*

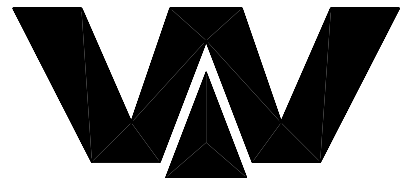

*Waitzinger  
Baumaschinen GmbH*

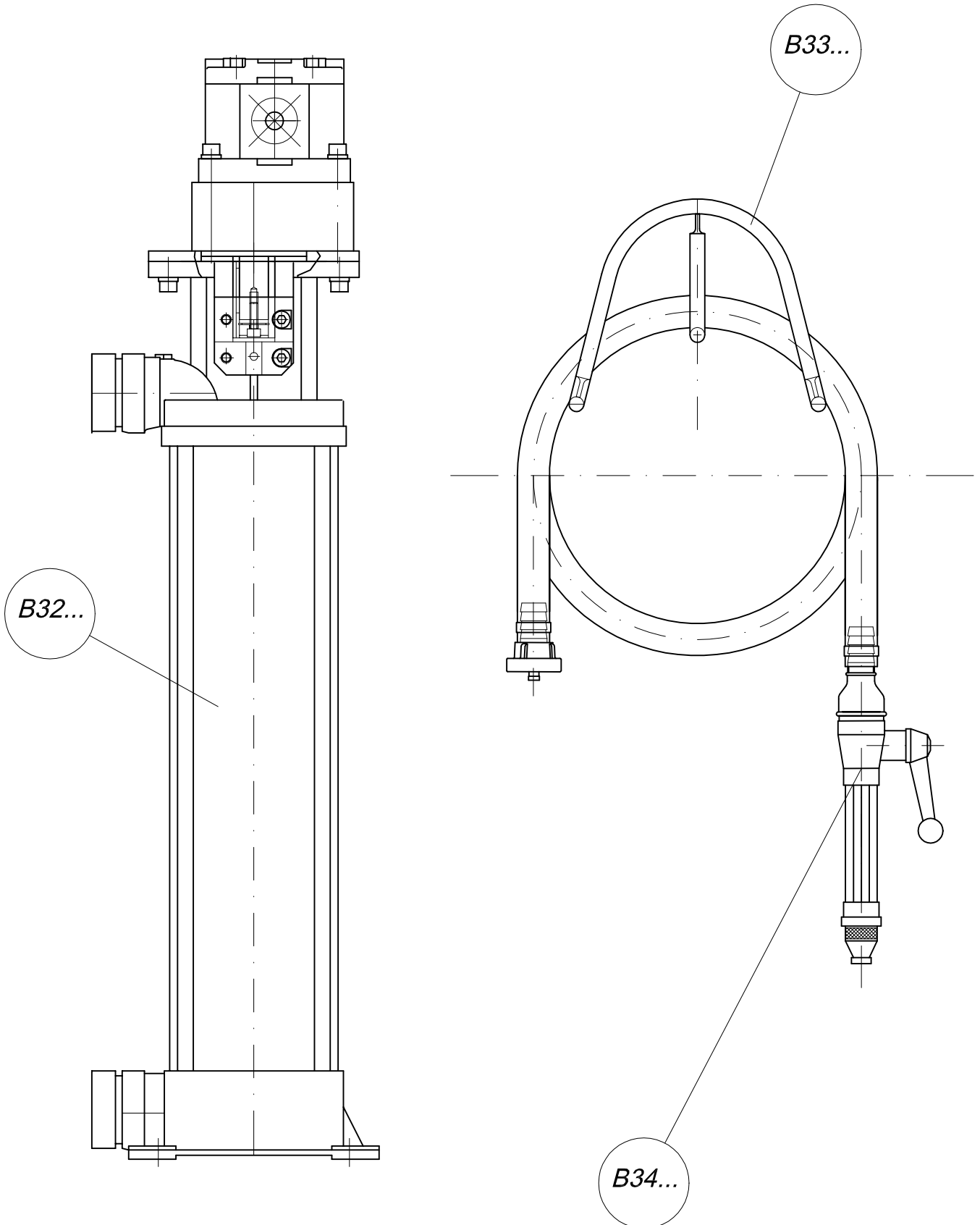

*Wassertank kpl.*  
*water tank cpl.*

**B 31 8 020**

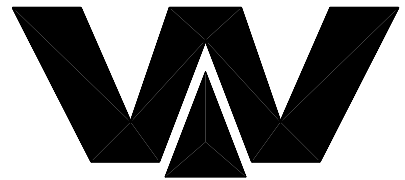

Waitzinger  
Baumaschinen GmbH

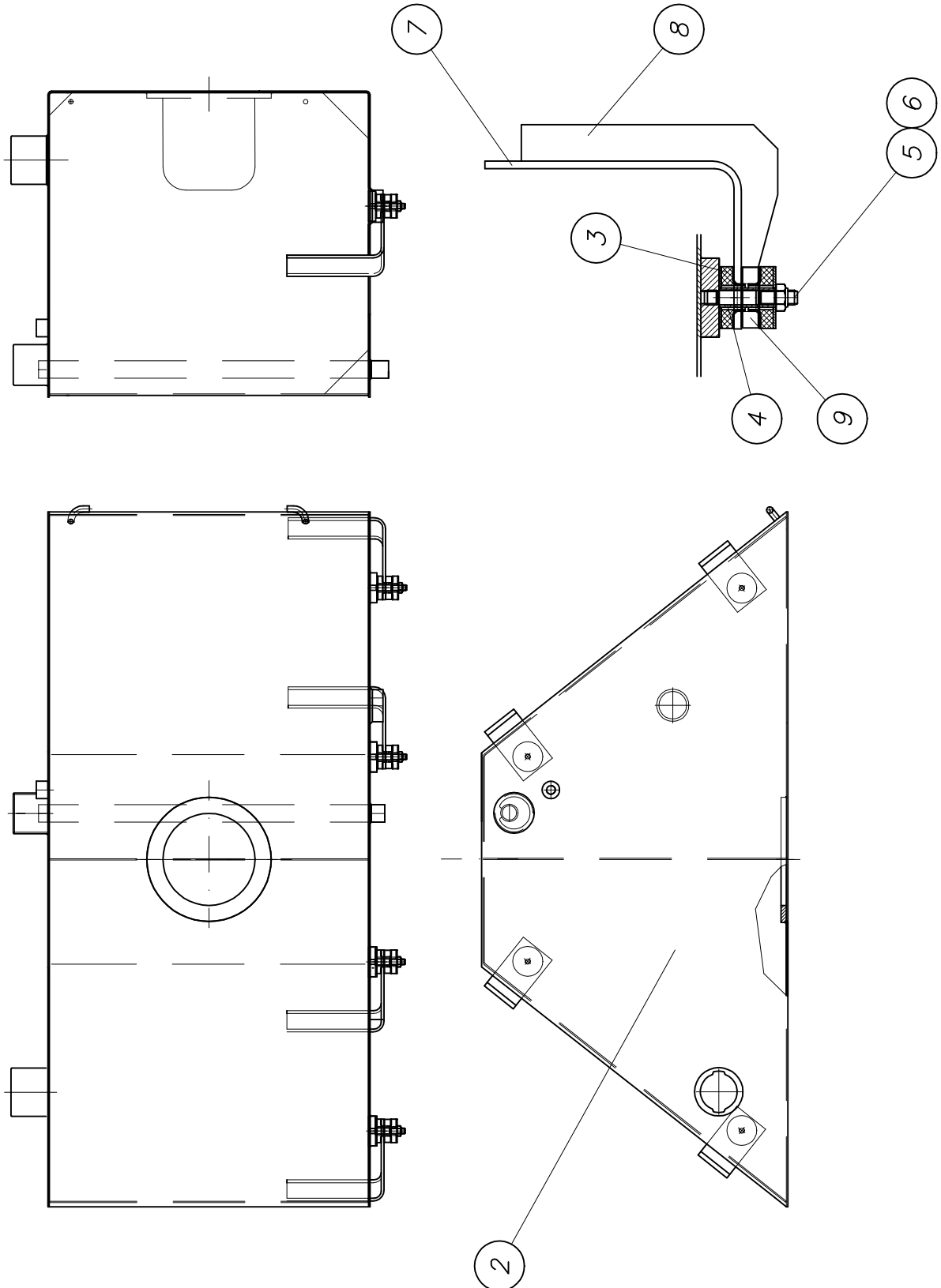



## PARTS LIST

part list	description	created	index	valid from	valid to	
B318020	water tank	28.11.03 ute				
pos	description stock	ident-no dimensions	DIN material	index	weigh Kg	quantity unit
2	water tank own parts list	B318010		a 07.02.05		1,00 Stk
3	rubber buffer 50 x 16,5 x 13	WAI102491			0,06	8,00 Stk
4	pipe	B474066 Hydr.rohr 16x2x	2391 St37		0,05	4,00 Stk
5	stop nut M12	WAI102121			0,02	4,00 Stk
6	pin bolt	WAI103177				4,00 Stk
7	angle	B478031 FI 80x10	1017 S235J2G3		2,00	4,00 Stk
8	rib	B478032 Bl 8x211x117	1543 S235J2G3		0,75	4,00 Stk
9	disk	B478028 Rd 15x50	DIN 1013 S235J2G3		0,20	4,00 Stk

*Wasserpumpe mit Antrieb kpl.*  
*water pump with drive cpl.*

**B 32 8 010b**

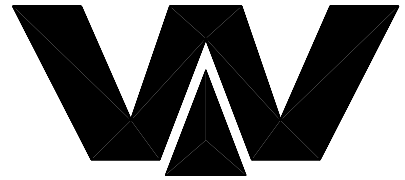

Waitzinger  
 Baumaschinen GmbH

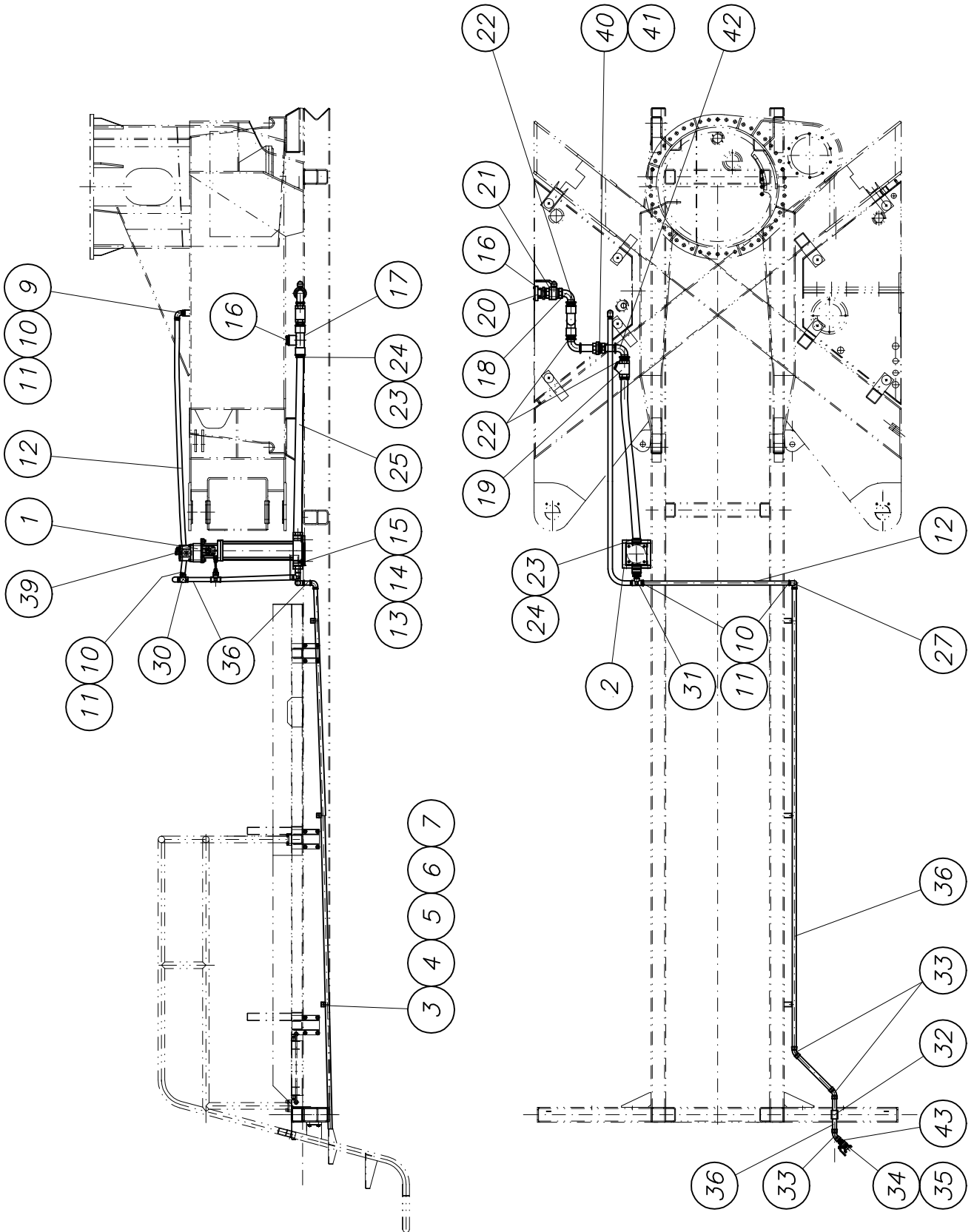



## PARTS LIST

part list	description	created	index	valid from	valid to	
B328010	water pump with drive	12.03.04 ek	b	07.02.05		
pos	description stock	ident-no dimensions	DIN material	index	weigh Kg	quantity unit
1	water pump with drive own parts list	B323070				1,00 Stk
2	holder for water pump	B323063 B112x330x150	EN 10029 S235J2G3		4,00	1,00 Stk
3	holder own parts list	B323048			0,20	3,00 Stk
4	pipe clamp	WAI107219				3,00 Stk
5	hex. bolt M6 x 10	WAI104005				3,00 Stk
6	spring washer A6	WAI103000				3,00 Stk
7	hex. nut M6	WAI102998				3,00 Stk
9	bow	WAI101735				1,00 Stk
10	hose socket	WAI105993				4,00 Stk
11	hose clamp 25-28 mm	WAI108309				4,00 Stk
12	hose	WAI102117				3,25 Mtr
13	hexagon bolt	WAI100503			0,05	4,00 Stk
14	washer	WAI100504				4,00 Stk
15	nut M12 DIN 934	WAI101557			0,02	4,00 Stk
16	reducer 2" - 1 1/2"	WAI107010				2,00 Stk
17	t-piece 1 1/2"	WAI107181				1,00 Stk
18	angle section	WAI107011				2,00 Stk
19	dirt catcher 1 1/2"	WAI105231				1,00 Stk
20	c-coupling 2" DIN 14307	WAI100797				1,00 Stk
21	ball tap 1 1/2" DN 10	WAI100378			1,03	1,00 Stk
22	double nipple 1 1/2"	WAI103702				3,00 Stk





## PARTS LIST

part list	description	created	index	valid from	valid to	
B328010	water pump with drive	12.03.04 ek	b	07.02.05		
pos	description stock	ident-no dimensions	DIN material	index	weigh Kg	quantity unit
23	hose socket	WAI107182				2,00 Stk
24	hose clamp 50/20	WAI105369			0,22	2,00 Stk
25	hose DN40 suction	WAI102321				0,60 mtr
27	bow	WAI105992				2,00 Stk
30	relief valve 3/4" 20bar	WAI100274			0,56	1,00 Stk
31	t-piece	WAI103590				1,00 Stk
32	pipe clip 28mm complete	WAI105977				1,00 Stk
33	bow	WAI107208				3,00 Stk
34	ball valve 3/4"	WAI103571				1,00 Stk
35	coupling	WAI109498				1,00 Stk
36	pipe	WAI106807			1,65	6,00 Mtr
39	banjo coupling L8-G	WAI103762				1,00 Stk
40	fitting 1 1/2"	WAI107916				1,00 Stk
41	pipe	B323071 Rohr 48.3x3.25x	2440 S235J2G3		0,20	2,00 Stk
42	angle section	WAI103574				1,00 Stk
43	double nipple 3/4"	WAI103566				1,00 Stk

Wasserpumpe kpl.

water pump cpl.

B 32 3 070

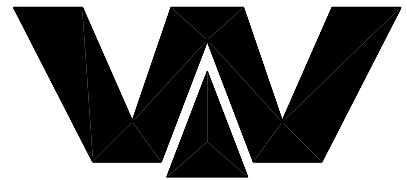

Waitzinger  
Baumaschinen GmbH

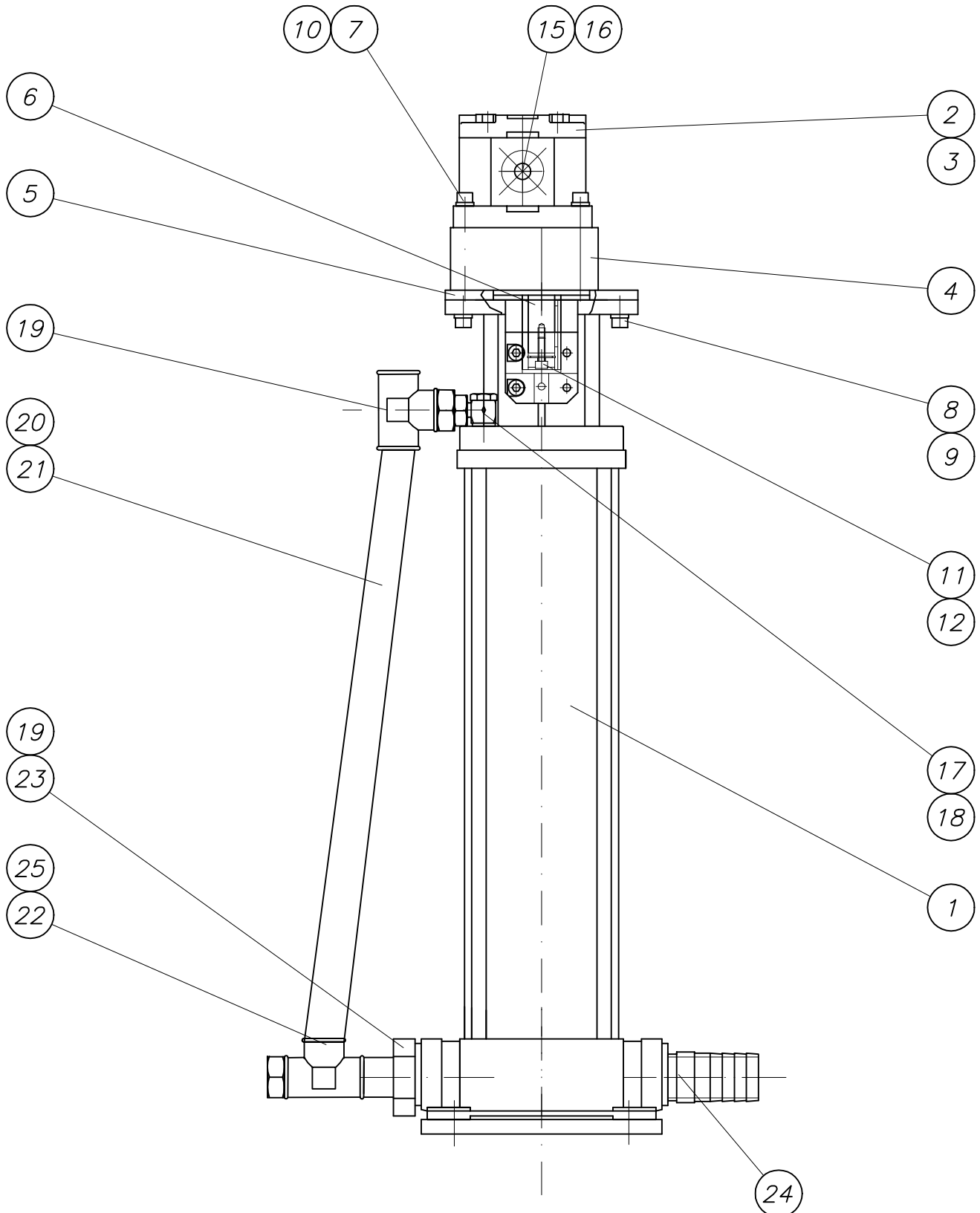



## PARTS LIST

part list	description	created	index	valid from	valid to	
B323070	water pump with drive	02.04.03 rhbk				
pos	description stock	ident-no dimensions	DIN material	index	weighth Kg	quantity unit
1	water pump INV	WAI108082				1,00 Stk
2	gear motor own parts list	WAI105922				1,00 Stk
3	splined coupling	WAI102916				1,00 Stk
4	belt pulley support	WAI102915				1,00 Stk
5	flange	B323061 Rd 170 x12	1013 S235J2G3		1,35	1,00 Stk
6	coupling piece	B323019 Rd 38x58	670 ST50-k			1,00 Stk
7	alien bolt M 8x70	WAI105929				4,00 Stk
8	alien bolt M 8x25	WAI105930				5,00 Stk
10	spring washer	WAI100235			0,00	8,00 Stk
11	locking ring	WAI105931				1,00 Stk
12	washer	B323023 Rd 22x6	670 St50-2k		0,05	1,00 Stk
15	elbow flange coupling L15-40	WAI102678			0,23	1,00 Stk
16	elbow flange coupling L12-35	WAI105921			0,23	1,00 Stk
17	bow	WAI104163				1,00 Stk
18	thread red.adaptors"3/4-3/8"	WAI100347			0,09	1,00 Stk
19	t-piece	WAI103590				2,00 Stk
20	hose	WAI102117				0,50 Mtr
21	hose clamp 25-28 mm	WAI108309				4,00 Stk
22	hose socket	WAI105993				1,00 Stk
23	double nipple 3/4"	WAI103566				1,00 Stk
24	nipple	B323059 Rohr 42.4x4.5x9	2448 S235J2G3		0,30	1,00 Stk
25	connecting piece waterpump	B323062 Rohr 42,2x4.5x6	2448 S235J2G3		0,30	1,00 Stk

*Halter für Wasserschlauch kpl.*  
*holder for water pipe cpl.*

**B 33 0 020**

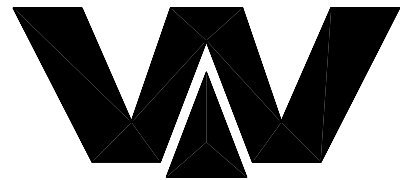

Waitzinger  
Baumaschinen GmbH

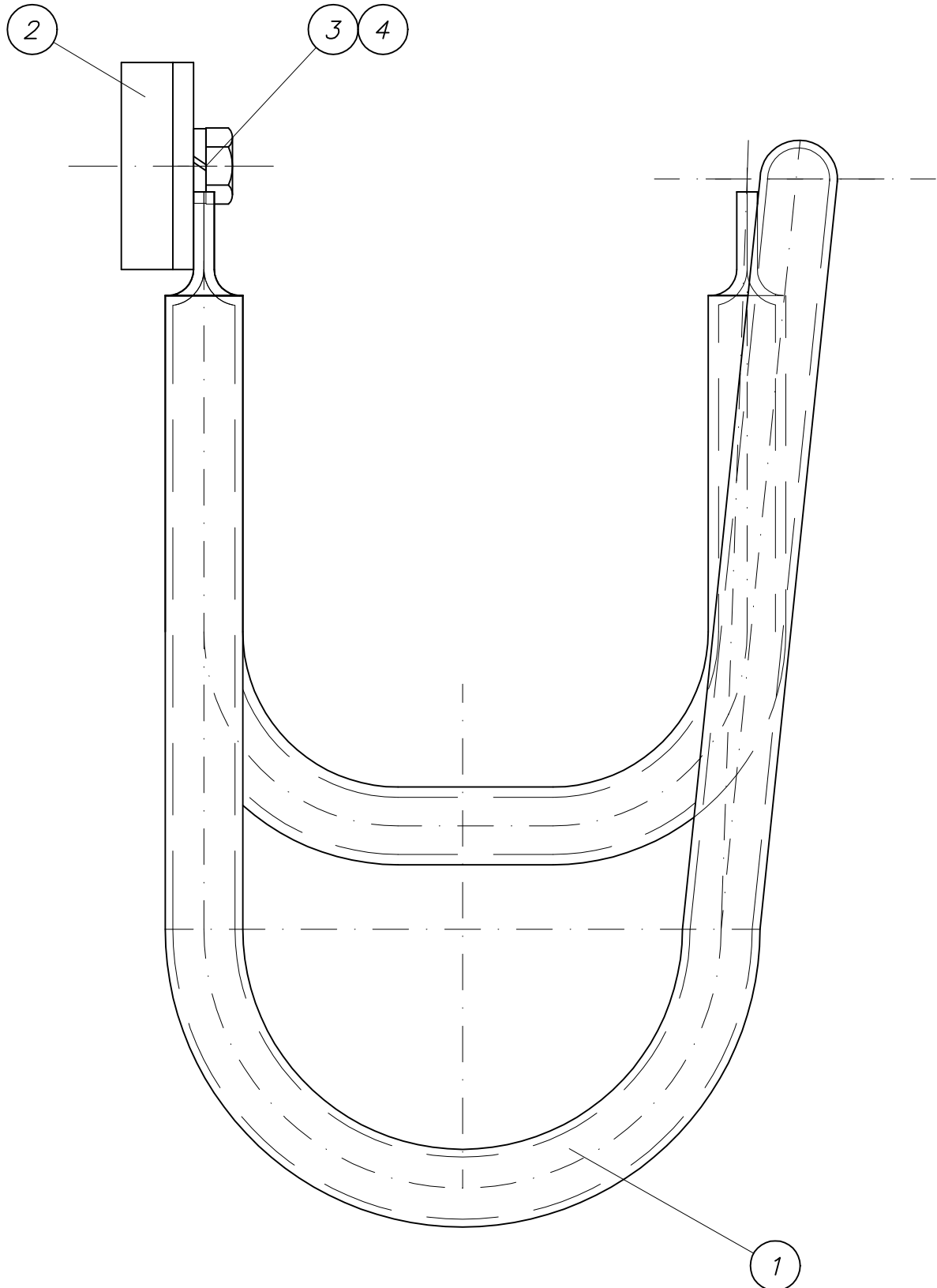



## PARTS LIST

part list	description	created	index	valid from	valid to	
B330020	holder for water hose	06.06.02 ek				
pos	description stock	ident-no dimensions	DIN material	index	weigh Kg	quantity unit
1	holder for water hose own parts list	B330015			1,00	1,00 Stk
2	flat bar	B330018 Bl 10x40x260	1543 St 37-2	a 27.09.02	0,30	1,00 Stk
3	hexagon bolt M 8 x 12 DIN 933 8.8	WAI103274				2,00 Stk
4	spring washer A8 DIN 127 VERZ.	WAI102205			0,00	2,00 Stk

*Schlauchleitung kpl.  
splash hose cpl.*

*B 34 1 005*

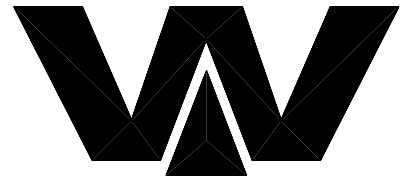

Waitzinger  
Baumaschinen GmbH

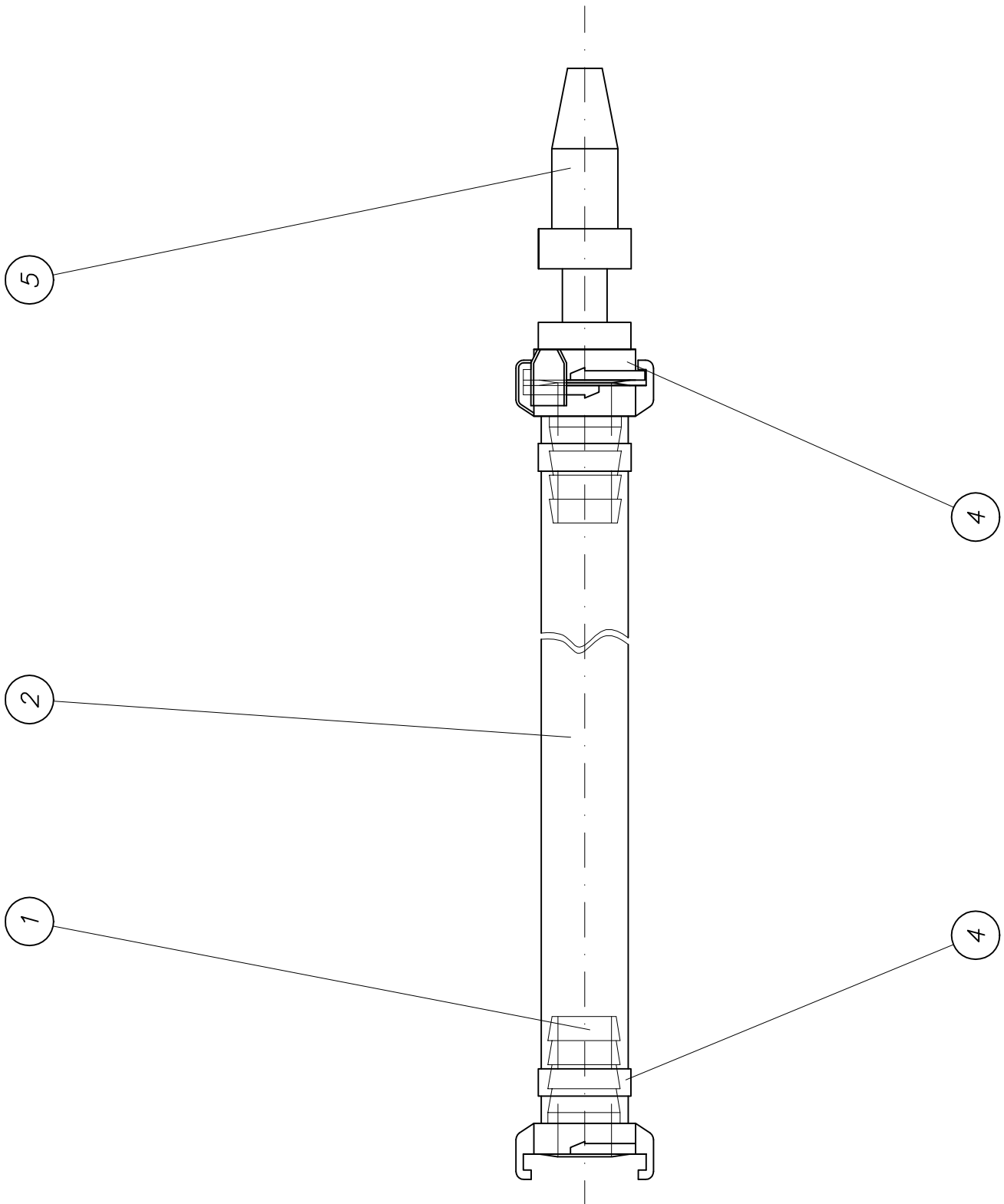



## PARTS LIST

part list	description	created	index	valid from	valid to	
B341005	splash hose cpl.	10.12.04 19400002				
pos	description stock	ident-no dimensions	DIN material	index	weighth Kg	quantity unit
1	hose piece	WAI102114				2,00 Stk
2	hose	WAI102117				5,00 Mtr
4	hose clamp 25-28 mm	WAI108309				2,00 Stk
5	nozzle 3/4"	WAI109368				1,00 Stk

*Übersicht B 40 - B 49*  
*over view B 40 - B 49*

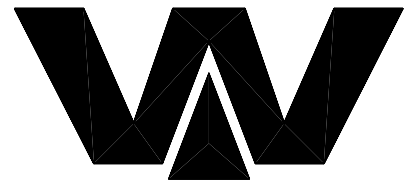

Waitzinger  
Baumaschinen GmbH

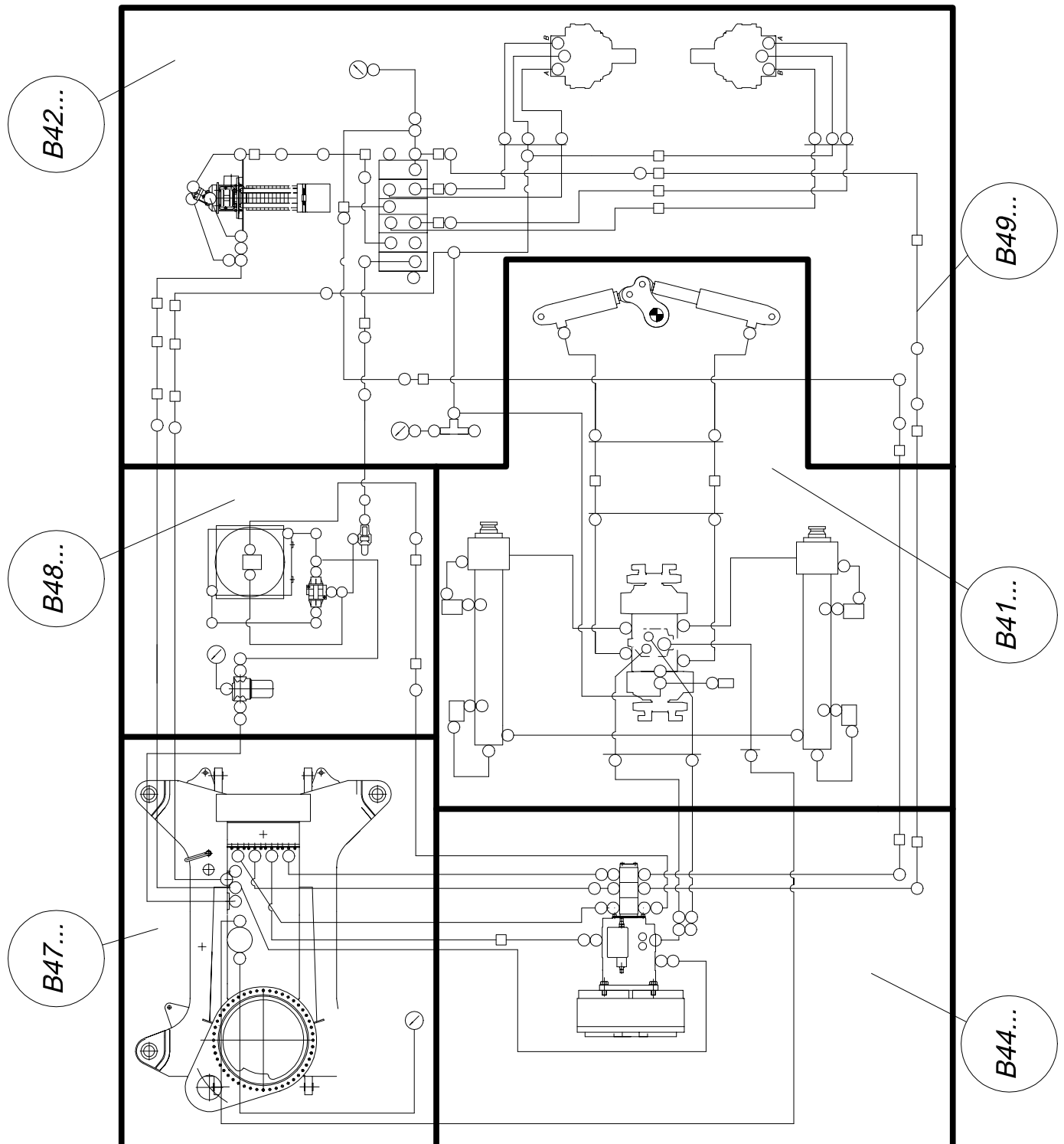









## PARTS LIST

part list	description	created	index	valid from	valid to	
B414048	pipng diagram, truck pump, pump unit	08.05.02 HF	b	01.03.05		
pos	description stock	ident-no dimensions	DIN material	index	weigh Kg	quantity unit
1	holder for hoses cpl. own parts list	B415002				2,00 Stk
2	mounting for control block own parts list	B414047				1,00 Stk
3	bulkhead plate	B474157 BI 10x90x105	1543/EN10029 St37-2	a	0,50	1,00 Stk
4	cross profile own parts list	B414054			8,00	1,00 Stk
5	fixing plate	B414024 BI 4x80x25	1543 St37-2			1,00 Stk
6	main control block own parts list	WAI102741			83,50	1,00 Stk
9	check valve LT-35B23.0-K	WAI100938			0,83	4,00 Stk
13	pressure switch	WAI100211			0,87	1,00 Stk
14	SAE-flange, 1 1/2", 6000 PSI complete own parts list	WAI102702				4,00 Stk
16	straight male stud couplings L42	WAI100550				1,00 Stk
18	bulkhead coupling L42	WAI105956				1,00 Stk
19	straight male stud couplings S38	WAI102184				2,00 Stk
20	straight male stud couplings S30	WAI100545				2,00 Stk
21	bulkhead coupling S30	WAI103047				2,00 Stk
23	straight male stud couplings S25	WAI100544				4,00 Stk
29	straight male stud couplings L15-G 1/2"	WAI101332				6,00 Stk
30	throttlefree banjo elbows L15 R	WAI101950				6,00 Stk
31	straight stud standpipe adaptor L15 G1/2	WAI101979				4,00 Stk
32	straight male stud couplings L8R 1/4"	wai105202				2,00 Stk
33	screw coupling	wai101199				1,00 Stk
42	male stud couplings S8RD 1/4	WAI105403				1,00 Stk



## PARTS LIST

part list	description	created	index	valid from	valid to	
B414048	piping diagram, truck pump, pump unit	08.05.02 HF	b	01.03.05		
pos	description stock	ident-no dimensions	DIN material	index	weigh Kg	quantity unit
43	throttle free banjo elbow S8R	WAI101174				1,00 Stk
49	swivel barrel tee S8	WAI108480			0,08	1,00 Stk
51	check point L8	WAI100209			0,08	2,00 Stk
52	check point R1/4"	WAI100137			0,07	2,00 Stk
53	pipe clip 38 mm, cpl. own parts list	WAI108096				2,00 Stk
60	hexagon bolt M 8 x 25 DIN 933 10.9	WAI103417				4,00 Stk
61	hexagon bolt M 8 x 20	WAI101837				1,00 Stk
62	cheese head screw M5x50	WAI101724			0,01	2,00 Stk
63	spring washer A8 DIN 127 VERZ.	WAI102205			0,00	5,00 Stk
64	washer 8.4	WAI101625				4,00 Stk
65	locking nut DIN 980	WAI102068				2,00 Stk

*Schlauchbefestigung kpl.*  
*pipe holder cpl.*

**B 41 5 002**

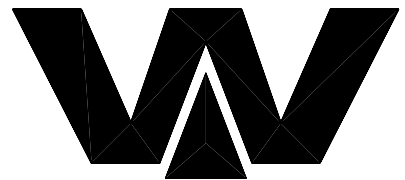

Waitzinger  
Baumaschinen GmbH

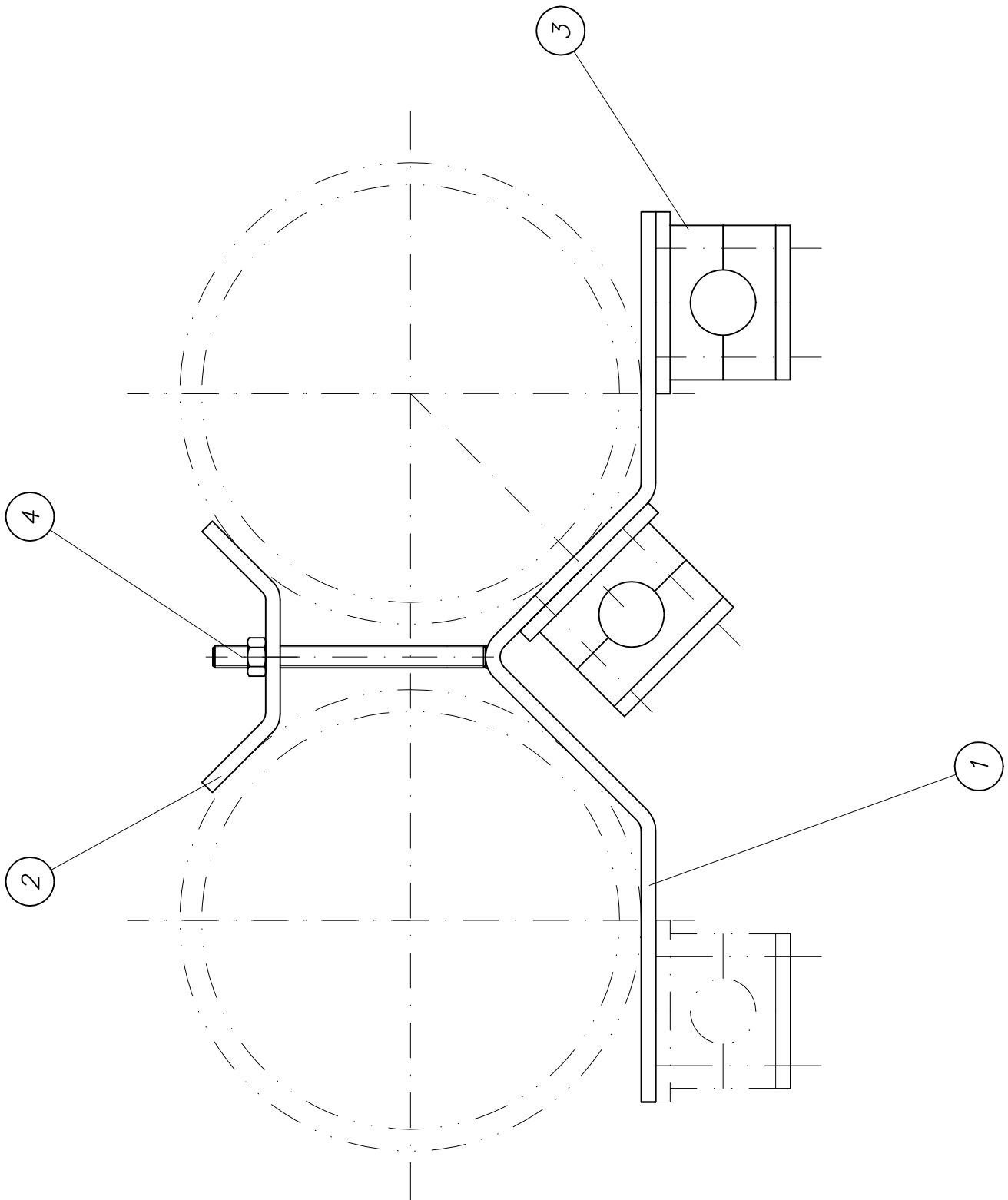



## PARTS LIST

part list	description	created	index	valid from	valid to	
B415002	holder for hoses cpl.	04.03.03 Mi				
pos	description stock	ident-no dimensions	DIN material	index	weighth Kg	quantity unit
1	support cpl. own parts list	B415004			2,50	1,00 Stk
2	plate	B414013 Bl 8x175x80	1543/EN10029 St37		0,65	1,00 Stk
3	pipe clip 38 mm, cpl. own parts list	WAI108096				2,00 Stk
4	nut M12 DIN 934	WAI101557			0,02	1,00 Stk

*Befestigung Steuerblock*  
*mounting control block*

*B 41 4 047*

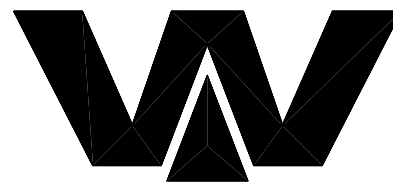

*Waitzinger*  
*Baumaschinen GmbH*

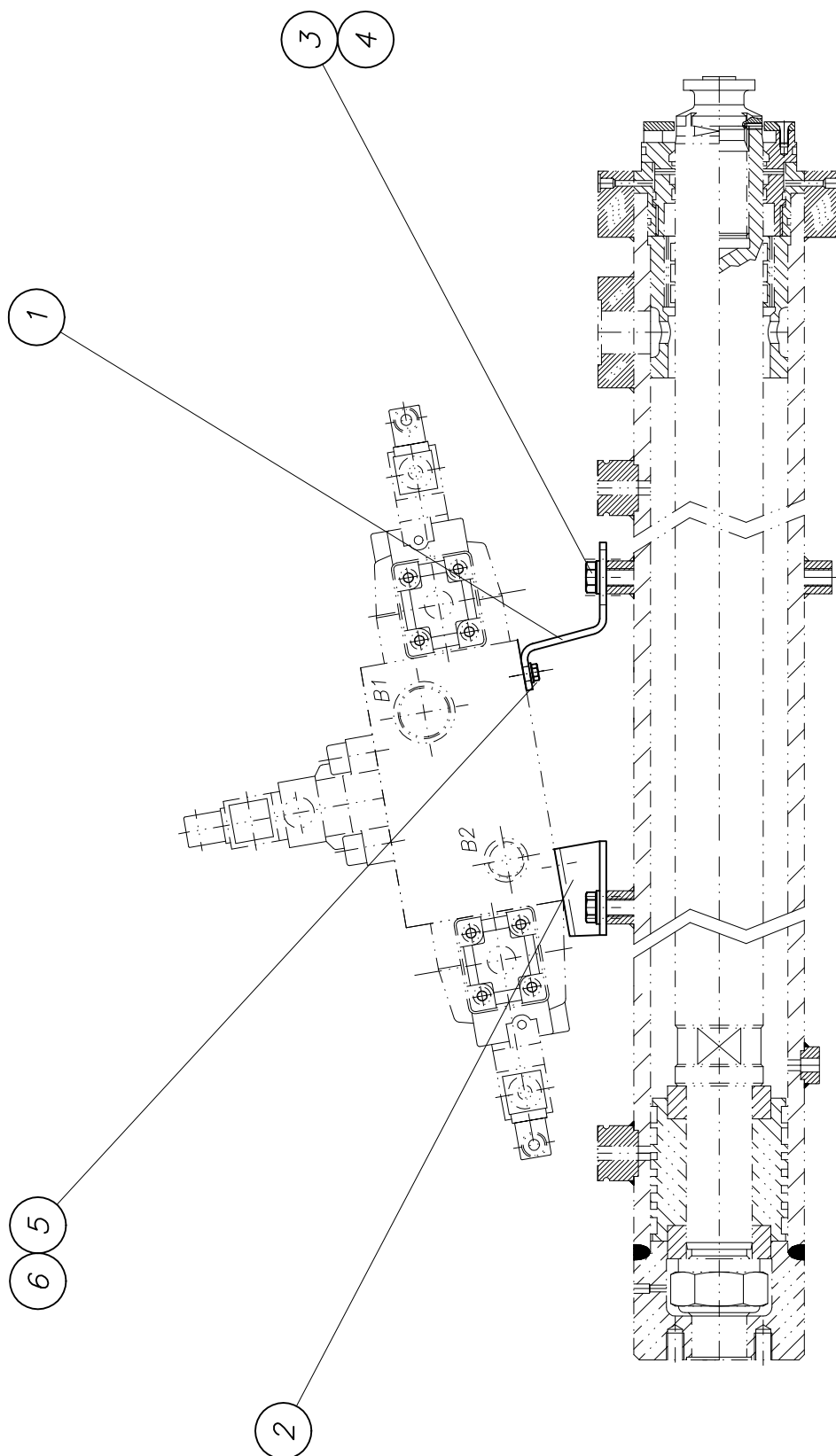



## PARTS LIST

part list	description	created	index	valid from	valid to	
B414047	mounting for control block	17.01.00 Mi				
pos	description stock	ident-no dimensions	DIN material	index	weighth Kg	quantity unit
1	angle	B113036 Bl 6x179x330	1543/EN10029 St37-2	a 24.01.00	2,50	1,00 Stk
2	angle	B113037 Bl 6x93x400	1543/EN10029 St37-2	a 24.01.00	1,40	1,00 Stk
3	hexagon bolt M16 x 30	WAI102892				4,00 Stk
4	conical spring washer	WAI100506				4,00 Stk
5	hexagon bolt M8 x 25 DIN 933 8.8	WAI101621				4,00 Stk
6	conical spring washer 8 mm	WAI103418				4,00 Stk



Hauptsteuerblock  
main control block

WAI 102741

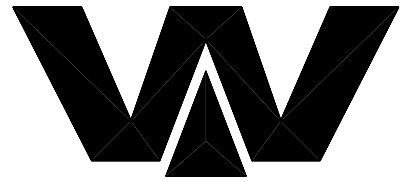

Waitzinger  
Baumaschinen GmbH

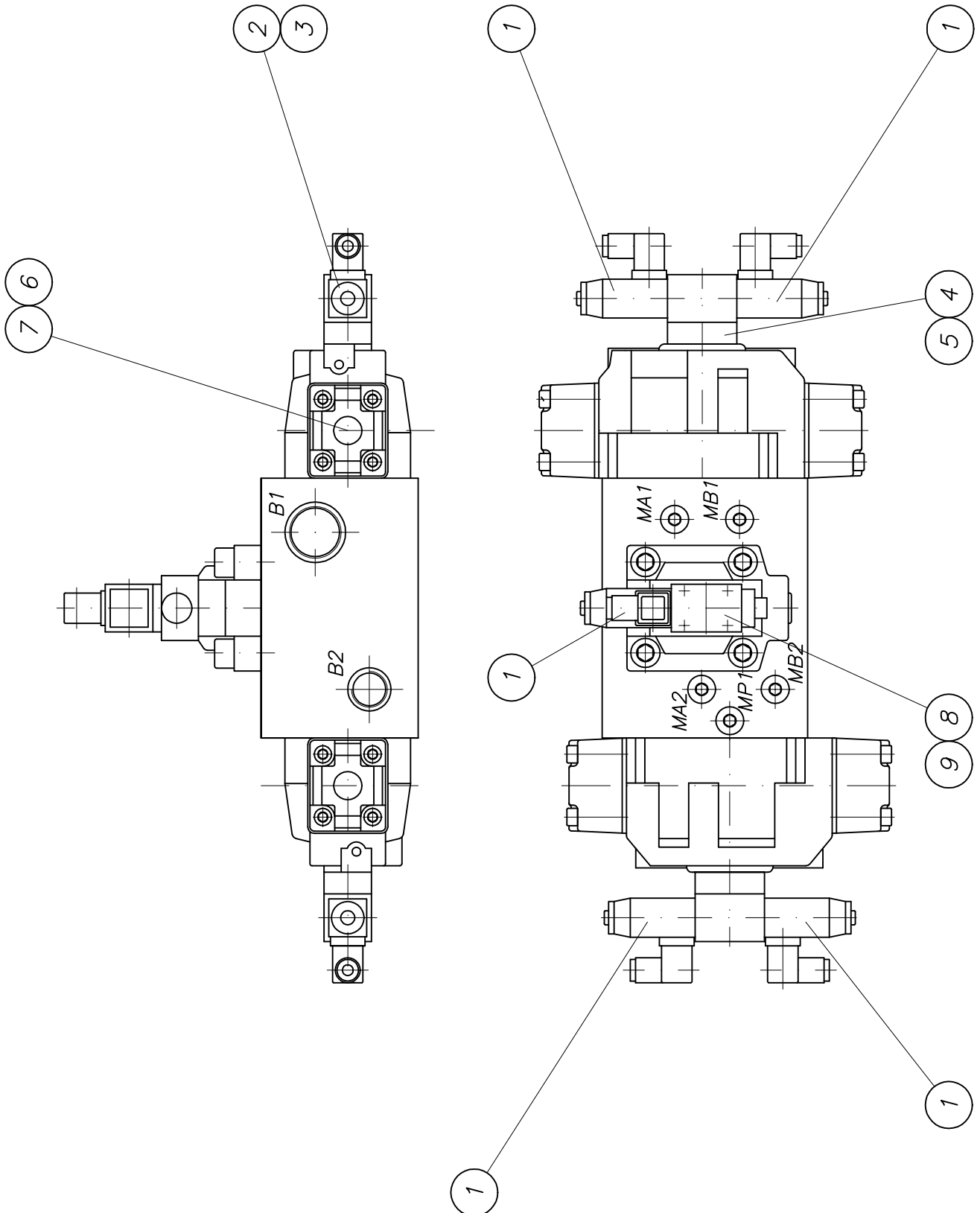



## PARTS LIST

part list	description	created	index	valid from	valid to	
WAI102741	main control block	14.08.01 Mi				
pos	description stock	ident-no dimensions	DIN material	index	weighth Kg	quantity unit
1	magnet coil GZ 45-4- 26V	WAI102396			0,35	5,00 Stk
2	4/3 way valve	WAI103159				2,00 Stk
3	sealing set for 4/3 way valve	WAI103160			0,10	2,00 Stk
4	subplate pressure valve	WAI102870				2,00 Stk
5	sealing set for spacer plate	WAI103161				2,00 Stk
6	regulation valve	WAI103162				2,00 Stk
7	sealing set for regulation valve	WAI103163				2,00 Stk
8	relief valve DBW30	WAI101030			7,00	1,00 Stk
9	sealing set for pressure	WAI103156				1,00 Stk

# Rührwerk u. Wasserpumpe agitator and water pump

B 42 4 006a

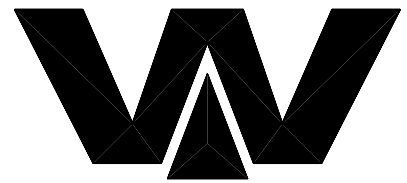

Waitzinger  
Baumaschinen GmbH

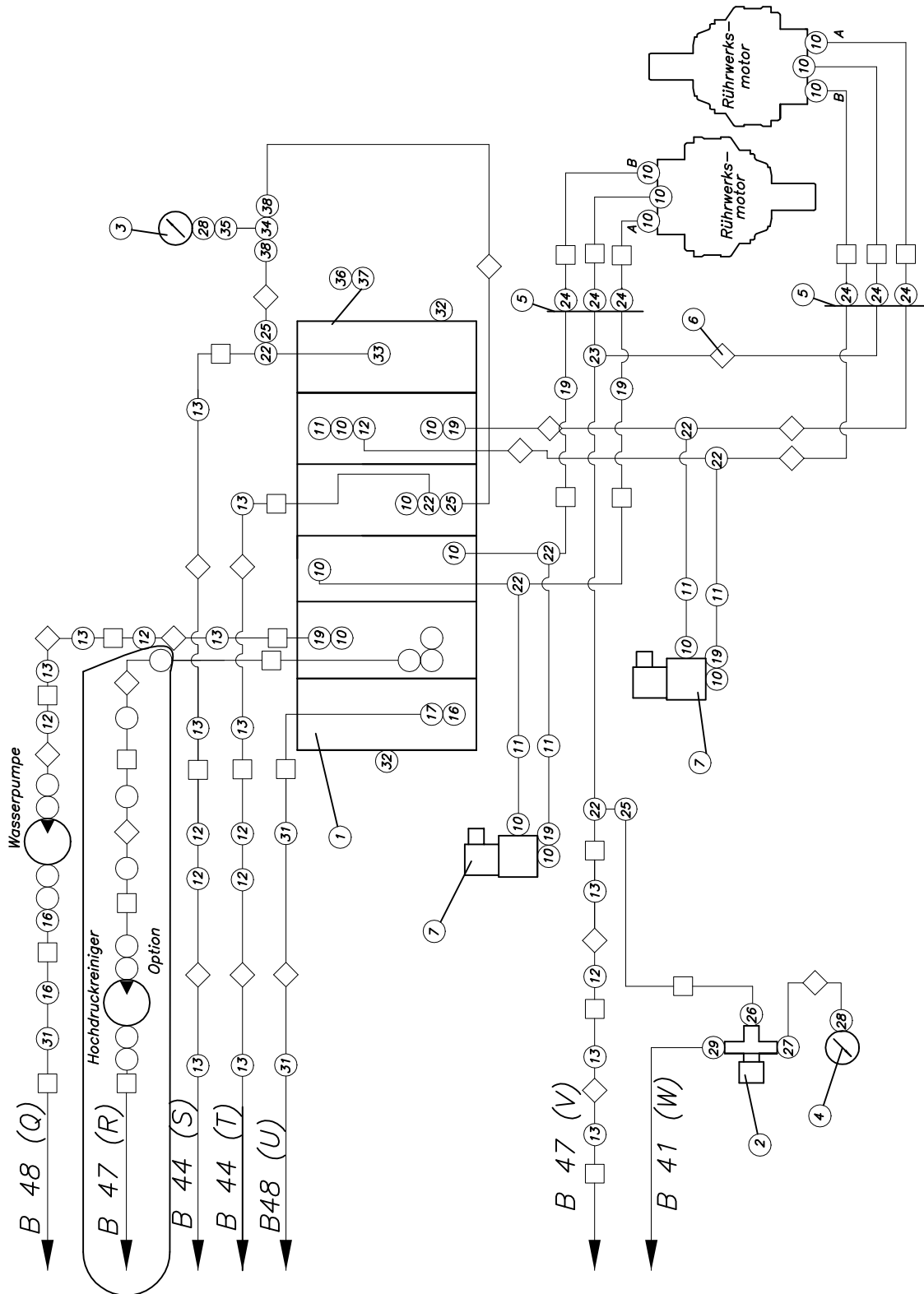



## PARTS LIST

part list	description	created	index	valid from	valid to	
B424006	pipng diagram, agitator and water pump	15.03.02 Mi	a	10.01.05		
pos	description stock	ident-no dimensions	DIN material	index	weighth Kg	quantity unit
1	mobil control block cpl. own parts list	B414043			6,90	1,00 Stk
2	hydraulic press button	WAI100136			0,42	1,00 Stk
3	pressure gauge 400bar 1/4"	WAI100160			0,28	1,00 Stk
4	pressure gauge 1/4" / 600 bar	WAI100132			0,27	1,00 Stk
5	bulkhead plate	B424007 BI 4x60x120	1543 S355J2G3		0,20	2,00 Stk
6	set of pipes for agitator control block	WAI106200				1,00 Stk
7	2/2 way valve	WAI107171				2,00 Stk
10	straight male stud couplings L12 3/8"	WAI103741				16,00 Stk
11	straight coupling SNV 12L	WAI101949				5,00 Stk
12	elbow couplings L12	WAI100604				8,00 Stk
13	straight couplings L12	WAI100603				12,00 Stk
16	swivel elbow L15	WAI101333				3,00 Stk
17	straight male stud couplings L15-G 1/2"	WAI101332				1,00 Stk
19	swivel elbow L12	WAI100590				6,00 Stk
22	swivel barrel tee L12	WAI101325				7,00 Stk
23	tee coupling L12	WAI100598				1,00 Stk
24	bulkhead coupling L12	WAI101384				6,00 Stk
25	standpipe tube reducer L12/8	WAI100564				3,00 Stk
26	banjo coupling L8R	WAI101196				1,00 Stk
27	straight male stud couplings L8RD 1/4	WAI100547			0,04	1,00 Stk
28	gauge couplings L8	WAI100581				2,00 Stk
29	check point R1/4"	WAI100137			0,07	1,00 Stk



## PARTS LIST

part list	description	created	index	valid from	valid to	
B424006	pipng diagram, agitator and water pump	15.03.02 Mi	a	10.01.05		
pos	description stock	ident-no dimensions	DIN material	index	weigth Kg	quantity unit
31	straight couplings L 15	WAI103754				3,00 Stk
32	socket head port plugs G 1/2	WAI100360			0,04	2,00 Stk
33	straight male stud couplings L12	WAI101386				1,00 Stk
34	valve L 8	WAI105858				1,00 Stk
35	straight coupling SNV 8L	WAI101938				1,00 Stk
36	hexagon bolt M 8 x 16 DIN 933 8.8	WAI102873				4,00 Stk
37	spring washer A8 DIN 127 VERZ.	WAI102205			0,00	4,00 Stk
38	adjustable elbow bodies L8	WAI103793				2,00 Stk

*Verrohrung Hydraulikpumpe*  
*diagram hydraulic pump*

*B 44 4 030d*

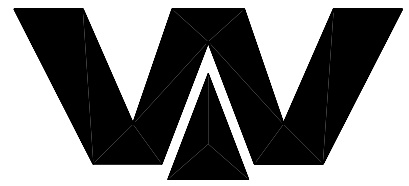

*Waitzinger*  
*Baumaschinen GmbH*

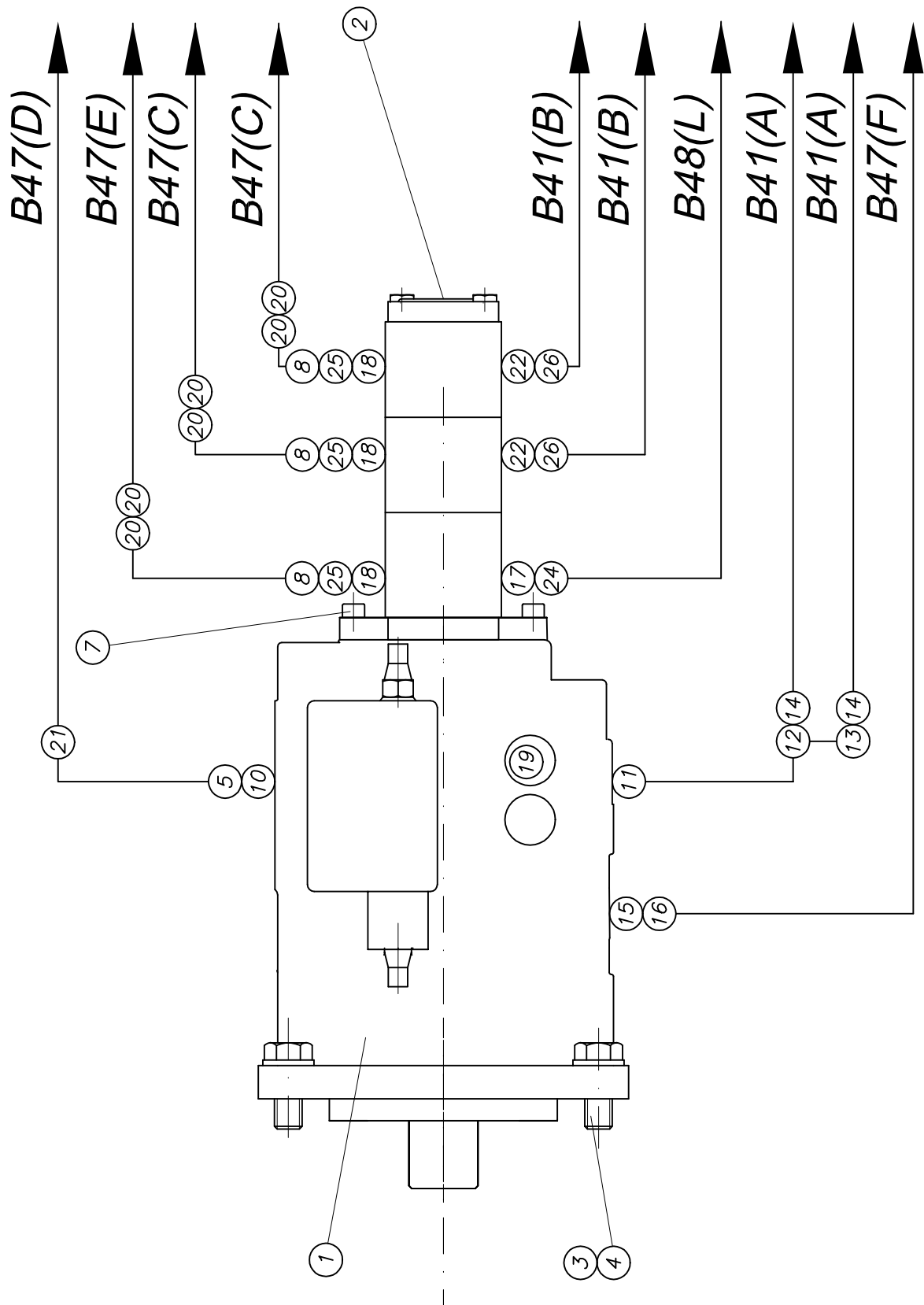



## PARTS LIST

part list	description	created	index	valid from	valid to	
B444030	pipng diagram hydraulic pump	02.04.02 ek	d	13.01.05		
pos	description stock	ident-no dimensions	DIN material	index	weigh Kg	quantity unit
1	pump A11VLO190LRDU2/11R-NSD12K01	WAI107493			114,00	1,00 Stk
2	triple gear pump own parts list	WAI105847			3,00	1,00 Stk
3	hexagon bolt M 20 x 65 DIN 931 8.8	WAI102940				4,00 Stk
4	washer HV	WAI100691			0,01	4,00 Stk
5	hose connection DN 100,SAE-flange 3 1/2"	WAI105871				1,00 Stk
7	socket head screw M 8 x 30	WAI105751				4,00 Stk
8	hose connection DN32, DKOL28, straight	WAI105170				3,00 Stk
10	SAE-flange, 3 1/2" 500 PSI complete	WAI102900				1,00 Stk
11	elbow flange coupling S38	WAI101963				1,00 Stk
12	swivel barrel tee S38	WAI101959			1,00	1,00 Stk
13	swivel elbow S38	WAI102216				1,00 Stk
14	standpipe tube reducer S38/30	WAI102217				2,00 Stk
15	throttlefree banjo elbows L28M	WAI103768				1,00 Stk
16	elbow couplings L28	WAI101396				1,00 Stk
17	elbow flange coupling L15-35	WAI102677			0,23	1,00 Stk
18	straight flange coupling L28-40	WAI102869				3,00 Stk
19	locking screw M 14 X 1,5	WAI102119			0,02	1,00 Stk
20	hose clamp 42/20	WAI103141			0,22	6,00 Stk
21	hose clamp 110/25	WAI103140			0,22	2,00 Stk
22	straight flange coupling L12-35	WAI108603				2,00 Stk
23	sealing ring 165 x 4	WAI102554				1,00 Stk



# PARTS LIST

part list	description	created	index	valid from	valid to	
B444030	pipng diagram hydraulic pump	02.04.02 ek	d	13.01.05		
pos	description stock	ident-no dimensions	DIN material	index	weigh Kg	quantity unit
24	swivel elbow L15	WAI101333				1,00 Stk
25	standpipe elbows L 28 D	WAI104435				3,00 Stk
26	swivel elbow L12	WAI100590				2,00 Stk



*Pumpe PNN 11*

*pump PNN 11*

*WAI 105847*

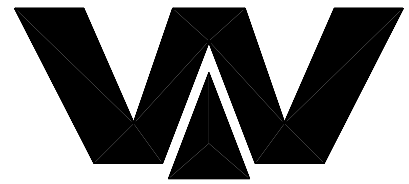

*Waitzinger  
Baumaschinen GmbH*

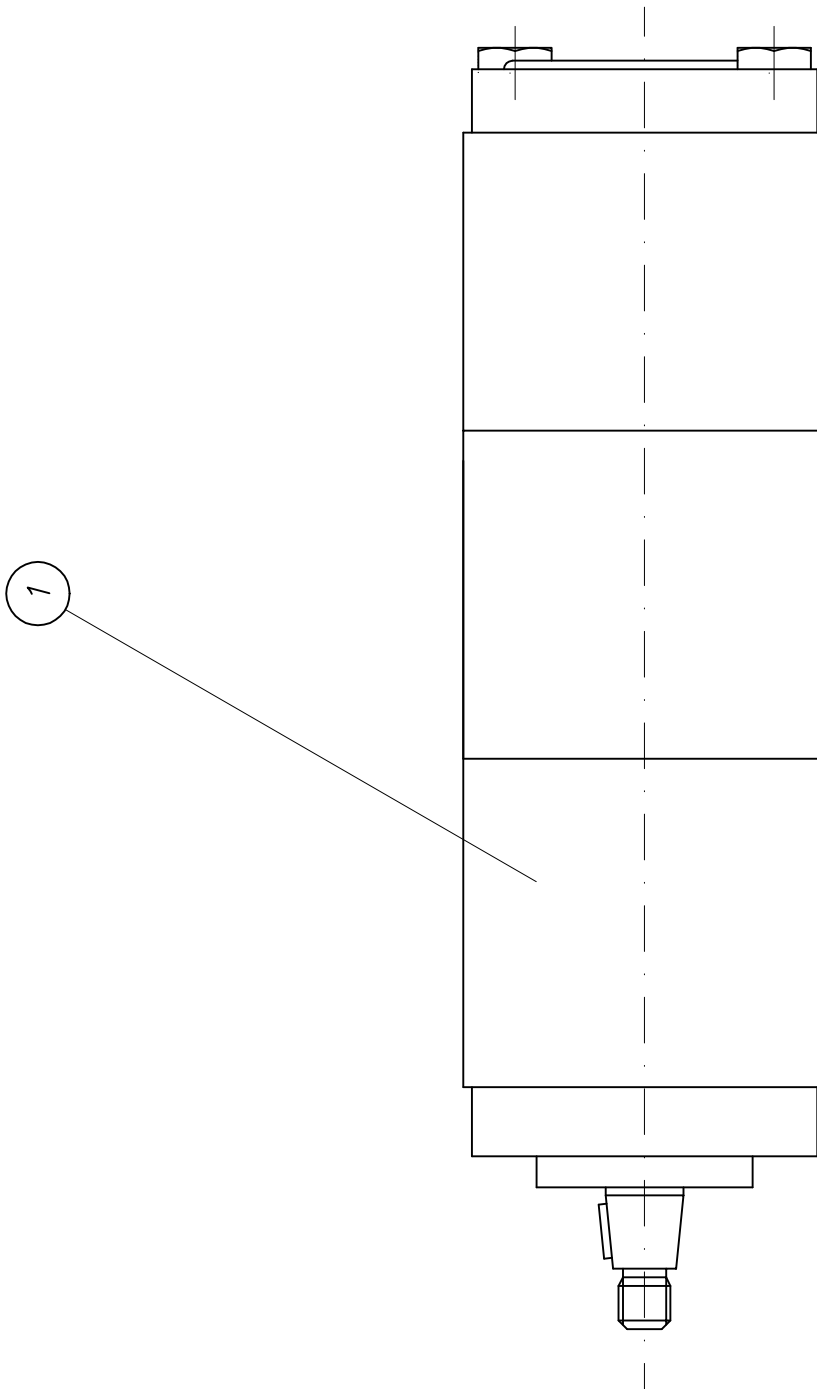



## PARTS LIST

part list	description	created	index	valid from	valid to	
WAI105847	tripple gear pump	09.10.01 Mi				
pos	description stock	ident-no dimensions	DIN material	index	weigh Kg	quantity unit
1	sealing set for gear pump	WAI107002				1,00 Stk

Öltank kpl.  
oil tank cpl.

B 47 8 010b

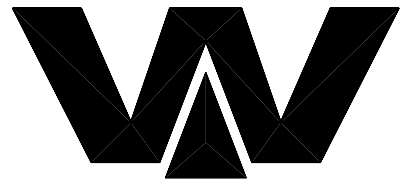

Waitzinger  
Baumaschinen GmbH

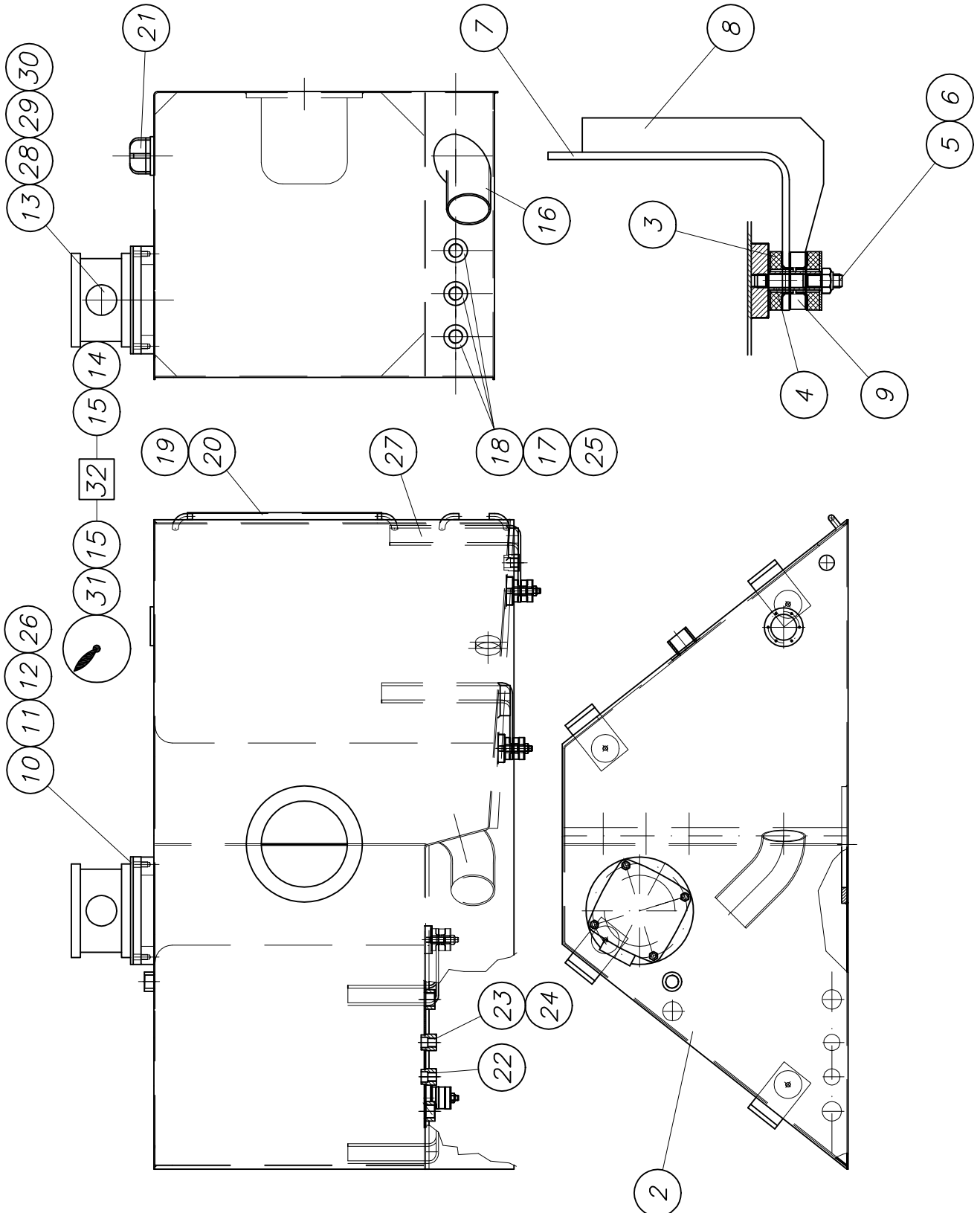



## PARTS LIST

part list	description	created	index	valid from	valid to	
B478010	oil tank	28.11.03 ute	b	03.03.05		
pos	description stock	ident-no dimensions	DIN material	index	weigh Kg	quantity unit
2	hydraulic tank cpl. own parts list	B478020				1,00 Stk
3	rubber buffer 50 x 16,5 x 13	WAI102491			0,06	8,00 Stk
4	pipe	B474066 Hydr.rohr 16x2x	2391 St37		0,05	4,00 Stk
5	stop nut M12	WAI102121			0,02	4,00 Stk
6	pin bolt	WAI103177				4,00 Stk
7	angle	B478031 FI 80x10	1017 S235J2G3		2,00	2,00 Stk
8	rib	B478032 BI 8x211x117	1543 S235J2G3		0,75	4,00 Stk
9	disk	B478028 Rd 15x50	DIN 1013 S235J2G3		0,20	4,00 Stk
10	filter RFM BN/HC851 own parts list	WAI106035			4,50	1,00 Stk
11	cheese head screw	WAI101792				4,00 Stk
12	spring washer A12 DIN 127 VERZ.	WAI102896				4,00 Stk
13	SAE-flange, 2", 3000 PSI complete	WAI103167				1,00 Stk
14	straight male stud couplings L6M	WAI100546			0,03	1,00 Stk
15	threaded sleeve	WAI100254			0,01	2,00 Stk
16	hose clamp 110/25	WAI103140			0,22	2,00 Stk
17	hose clamp 42/20	WAI103141			0,22	6,00 Stk
18	male stud couplings L28	WAI100337			0,25	3,00 Stk
19	fuel hose DN 12	WAI103104				0,50 Mtr
20	hose clamp 15mm	WAI103103				2,00 Stk
21	filling and air filter	WAI106163				1,00 Stk
22	throttlefree banjo elbows L28	WAI100364			0,89	2,00 Stk



## PARTS LIST

part list	description	created	index	valid from	valid to	
B478010	oil tank	28.11.03 ute	b	03.03.05		
pos	description stock	ident-no dimensions	DIN material	index	weigh Kg	quantity unit
23	male stud couplings L28 1"	WAI103746				2,00 Stk
24	standpipe elbows L 28 V	WAI100367			0,41	2,00 Stk
25	hose connection DN32, DKOL28, straight	WAI105170				3,00 Stk
26	filter element 0851R010BN/HC	WAI102700			2,50	1,00 Stk
27	angle	B478033 FI 80x10x426	1017 S235J2G3		2,70	2,00 Stk
28	flange	b474172 BI 30xD 130	1543 St 52-3		2,40	1,00 Stk
29	O-ring 69,4 x 3,5	wai103384				1,00 Stk
30	cheese head screw	wai101792				4,00 Stk
31	female stud couplings L6 M10 X 1	wai101406				1,00 Stk
32	plastic pipe	wai109384			0,50	3,00 Mtr





# PARTS LIST

part list	description	created	index	valid from	valid to	
B484065	pipng diagram oil cooler truck	16.02.04 Mi	c	11.11.04		
pos	description stock	ident-no dimensions	DIN material	index	weigth Kg	quantity unit
1	hydraulic oilcooler own parts list	WAI108527				1,00 Stk
2	filter element CS 050 - A10	WAI101376			2,00	1,00 Stk
4	flat bar	B484054 FI 30x12x233	1017 S235J2G3		0,60	2,00 Stk
5	holder kpl. own parts list	B484057			0,10	1,00 Stk
6	pipe clip 12 mm, own parts list	WAI105146			0,07	1,00 Stk
7	rubber cushion	WAI104190				4,00 Stk
8	stop nut M8 DIN985 8. VERZ.	WAI102111			5,00	4,00 Stk
9	washer 8.4	WAI101625				4,00 Stk
10	reducing thread adapter 1 1/4" - 1"	WAI100572				1,00 Stk
11	male stud couplings L28	WAI100337			0,25	1,00 Stk
12	swivel barrel tee L28	WAI101395				1,00 Stk
13	standpipe tube reducer L28/15	WAI101401				2,00 Stk
15	elbow flange coupling L15-35	WAI102677			0,23	1,00 Stk
16	male stud couplings L28	WAI103525				1,00 Stk
17	elbow couplings L28	WAI101396				1,00 Stk
18	elbow flange coupling L15-40	WAI102678			0,23	1,00 Stk
19	hexagon bolt M8 x 25 DIN 933 8.8	WAI101621				4,00 Stk
20	spring washer A8 DIN 127 VERZ.	WAI102205			0,00	4,00 Stk
26	hydr. pipe 28 x 2.0	WAI103562			1,30	0,20 Mtr
30	hydraulic hose DN 12 x 800	WAI105377				1,00 Stk

*Rohre und Schläuche kpl.*  
*hoses and pipes cpl.*

**B 49 4 034**

**1**

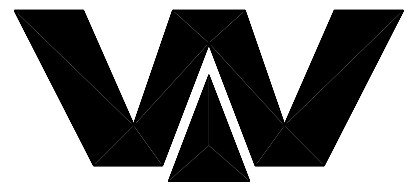

Waitzinger  
Baumaschinen GmbH

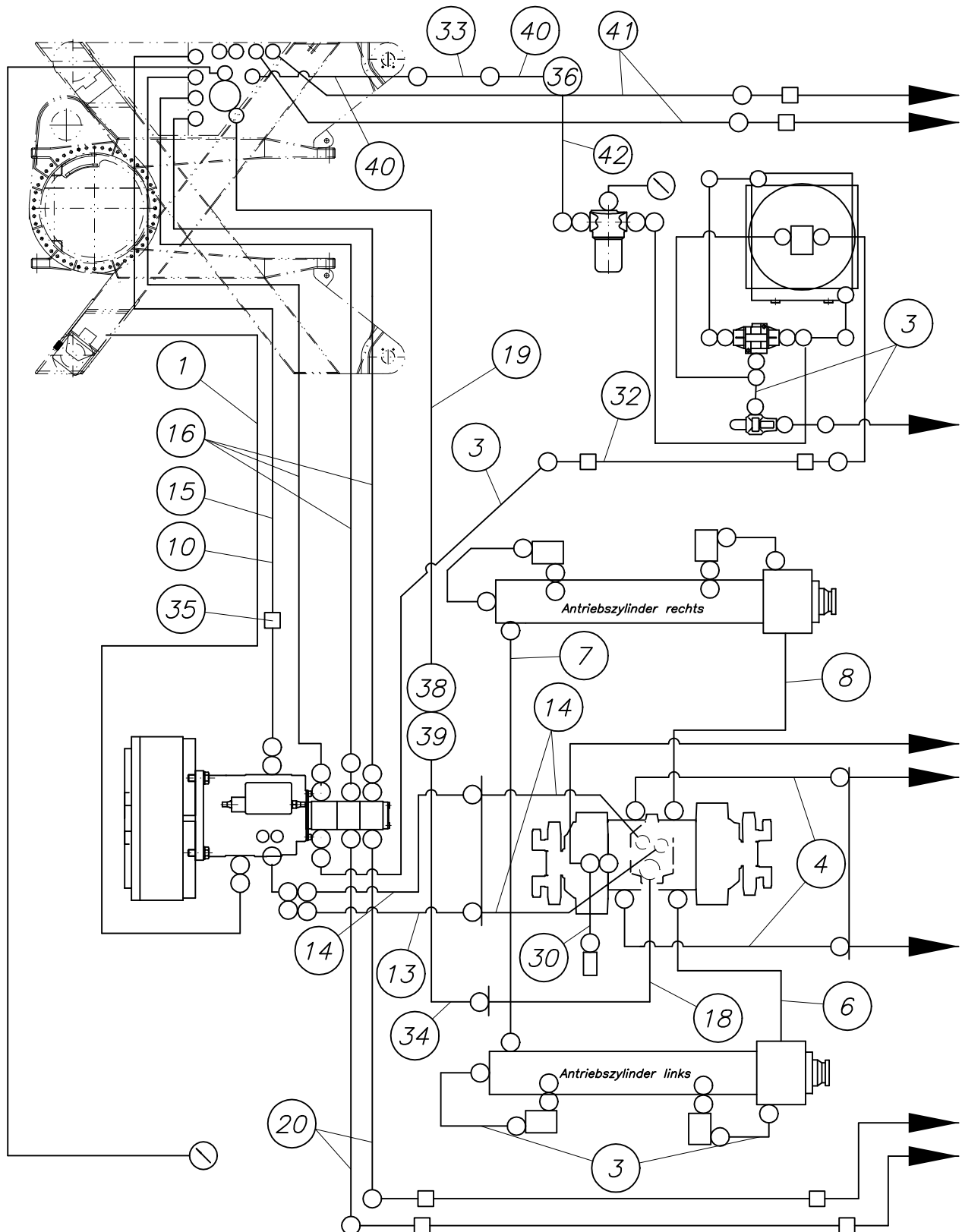



*Rohre und Schläuche kpl.*  
*hoses and pipes cpl.*

**B 49 4 034**

**2**

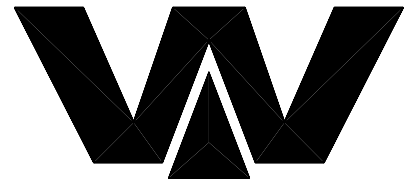

Waitzinger  
Baumaschinen GmbH

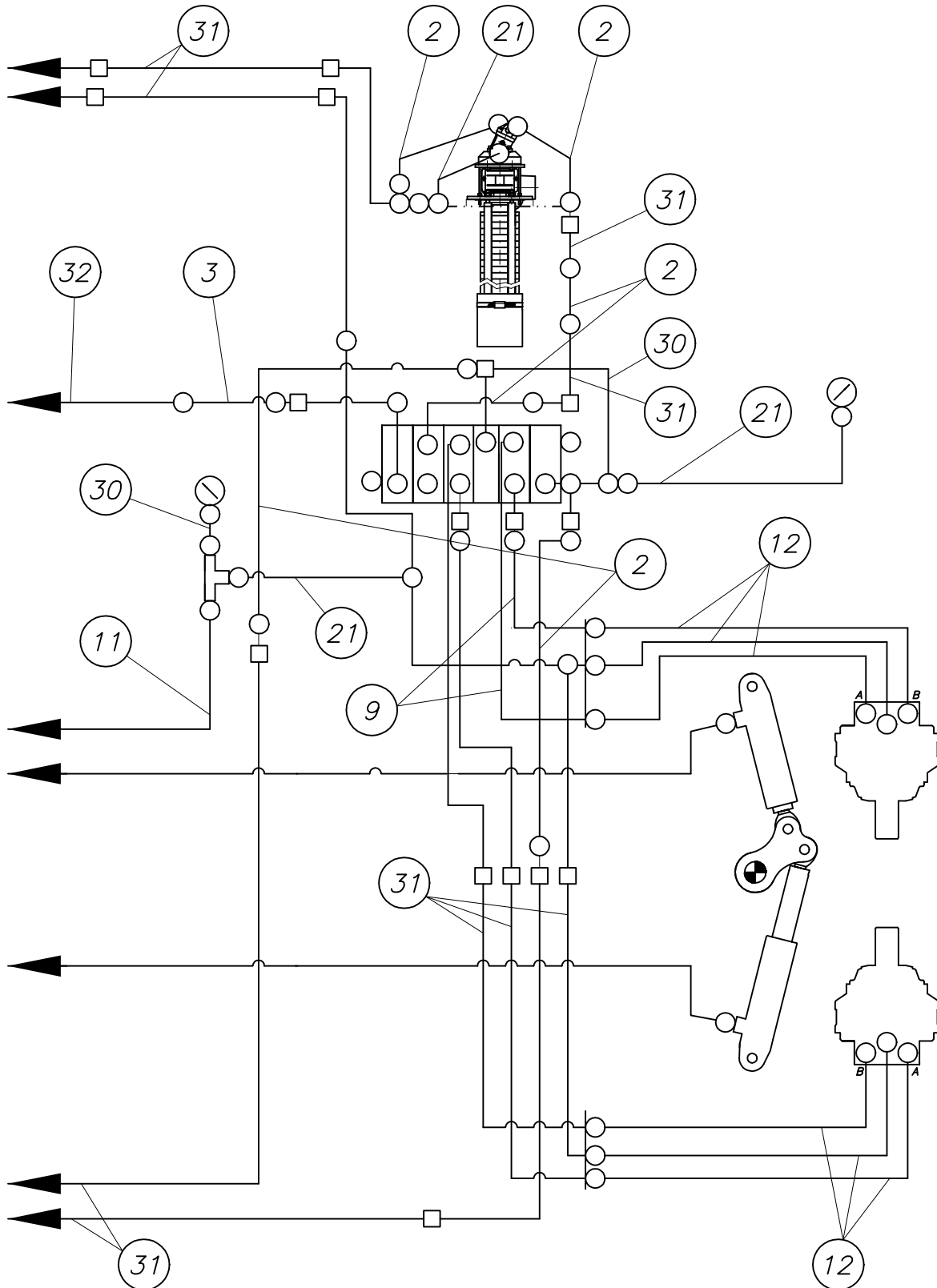



## PARTS LIST

part list	description	created	index	valid from	valid to	
B494034	pipng diagram hoses boom pump	30.04.04 ek				
pos	description stock	ident-no dimensions	DIN material	index	weigh Kg	quantity unit
1	hydraulic hose DN25 x 1250	WAI107249				1,00 Stk
2	hydraulic hose DN 10 x 500	WAI104147				6,00 Stk
3	hydraulic hose DN 12 x 700	WAI103207				6,00 Stk
4	hydraulic hose DN20x3820	WAI107221				2,00 Stk
6	hydraulic hose DN32x 580	WAI104447				1,00 Stk
7	hydraulic hose DN40 x 1100	WAI103222				1,00 Stk
8	hydraulic hose DN32 x 580	WAI104446				1,00 Stk
9	hydraulic hose DN10 x 450	WAI106001				2,00 Stk
10	pipe	B490002 Rohr 101.6x3.2x	DIN 2448 S235J2G3		3,90	1,00 Stk
11	monitoring connecting hose assy, 5000 mm	WAI104158				1,00 Stk
12	hydraulic hose DN 10 x 780	WAI103272				6,00 Stk
13	hydraulic hose DN 25 x 900	WAI108367				1,00 Stk
14	hydraulic hose DN 25 x 800	WAI105959				3,00 Stk
15	suction hose DN100	WAI105899				2,50 Mtr
16	suction hose DN 32	WAI105900				5,70 Mtr
18	hydraulic hose DN 40 x 1200	WAI105961				1,00 Stk
19	hydraulic hose DN40x1400	WAI105962				1,00 Stk
20	hydraulic hose DN 10 x 1000	WAI103206				2,00 Stk
21	hydraulic hose DN 6 x 500	WAI103515				4,00 Stk
30	hydr. pipe 8 x 1.5	WAI102309			0,24	3,00 Mtr
31	hydr. pipe 12 x 2	WAI102022			0,49	30,00 Mtr



## PARTS LIST

part list	description	created	index	valid from	valid to	
B494034	piping diagram hoses boom pump	30.04.04 ek				
pos	description stock	ident-no dimensions	DIN material	index	weigh Kg	quantity unit
32	hydr. pipe 15 x 2	WAI101717			0,65	6,00 Mtr
34	hydraulic hose DN 40 x 800	WAI108282				1,00 Stk
35	hose clamp 110/25	WAI103140			0,22	1,00 Stk
37	bulkhead plate	B474166 BI 8x60x80	1543 St37-2		0,50	1,00 Stk
39	bulkhead plate	B474157 BI 10x90x105	1543/EN10029 St37-2	a	0,50	1,00 Stk
40	hydraulic hose DN 25 x 800	WAI103229				2,00 Stk
41	hydraulic hose DN10 x 1250	WAI106508				2,00 Stk
42	hydraulic hose DN 25 x 1100	WAI103216				1,00 Stk
44	hydr. pipe 28 x 2.0, 6-Mtr.	WAI103440				1,00 Stk
45	pipe clip 12 mm, own parts list	WAI105146			0,07	12,00 Stk
46	pipe clip 28mm complete	WAI105977				2,00 Stk
47	pipe clip 15 mm,	WAI105147			0,07	4,00 Stk
48	pipe clip 22 mm,	WAI105384			0,07	2,00 Stk
49	pipe clip 18 mm,	WAI105148				4,00 Stk

*Übersicht B 50 - B 59*  
*over view B 50 - 59*

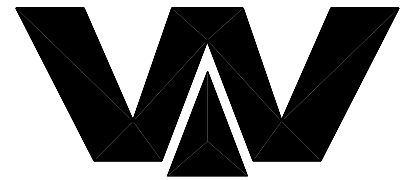

*Waitzinger*  
*Baumaschinen GmbH*

*B51...*

*Elektroschaltplan*  
*wiring diagram*

*B54...*

*Drehzahlverstellung*  
*rpm adjustment*

*B56...*

*Kabelbaum*  
*cable loop*

*B56...*

*Zubehör*  
*accessories*



P12.2a  
P12.2b  
P12.2c

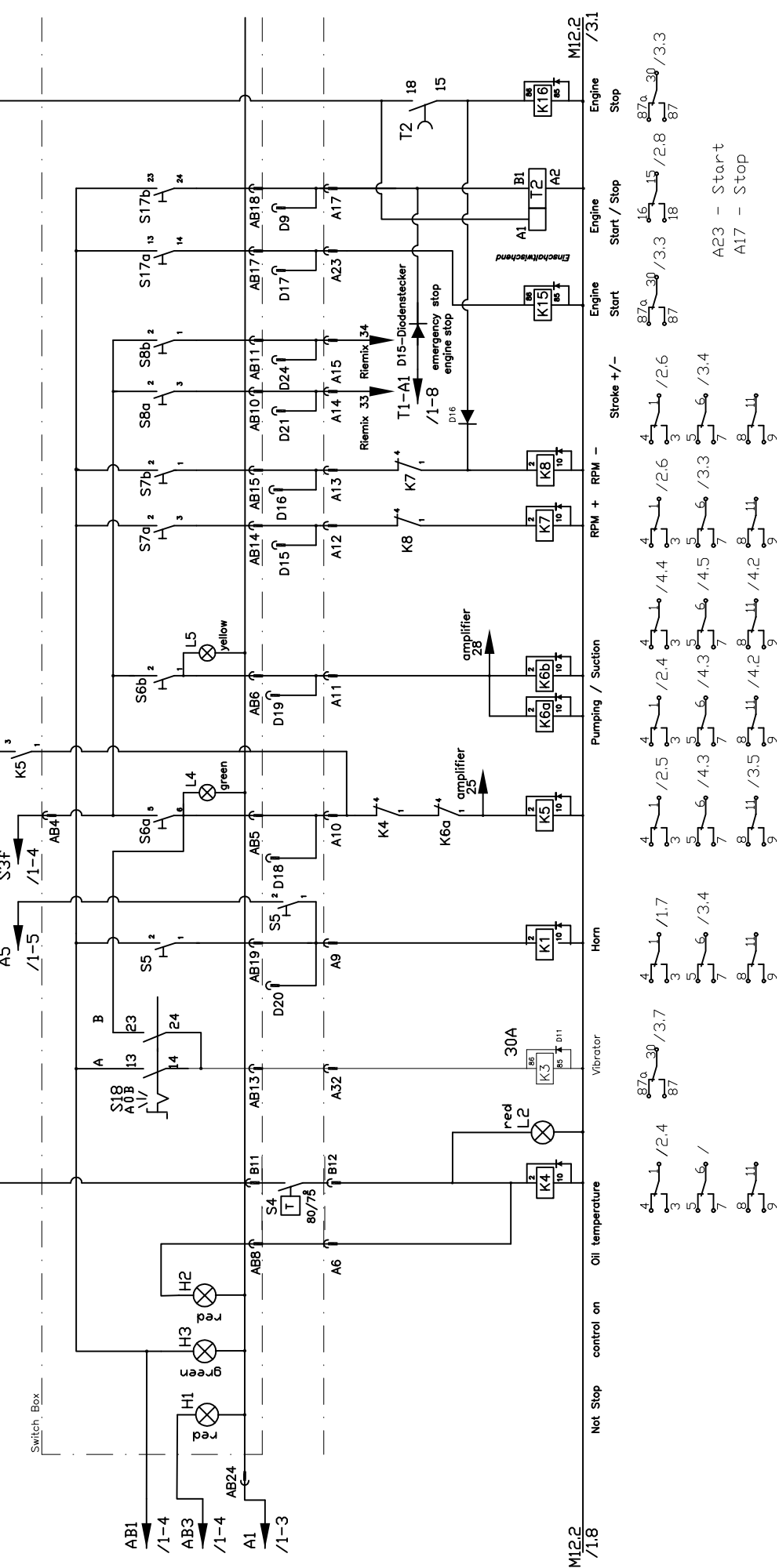

SCALE		WEIGHT	
Seite 2		Bedienpult	
FREE DIMENSION TOLERANCE DIN 7185 MEDIUM	DATE	NAME	
	23.03.04	Fetzer	
	CHKD.		
	APPD.		
d siehe B_513023.doc	01.06.05	Körner	
c siehe B_513023.doc	24.03.05	Körner	
b siehe B_513023.doc	01.03.05	Körner	
a siehe B_513023.doc	02.06.04	Körner	
ISSUE	MODIFICATION	DATE	NAME ORIGINAL

THIS INFORMATION MAY NOT BE COPIED BY A THIRD PARTY. SUBJECT TO COPYRIGHT (PARAGRAPH 1 NO. 3 OF "URheberRECHTSGESETZ" FROM 14.06.1991)

CHANGE ONLY WITH CAD

REPLACEMENT FOR

B 51 3 022

SHEET OF

P12.3a P12.3b P12.3c

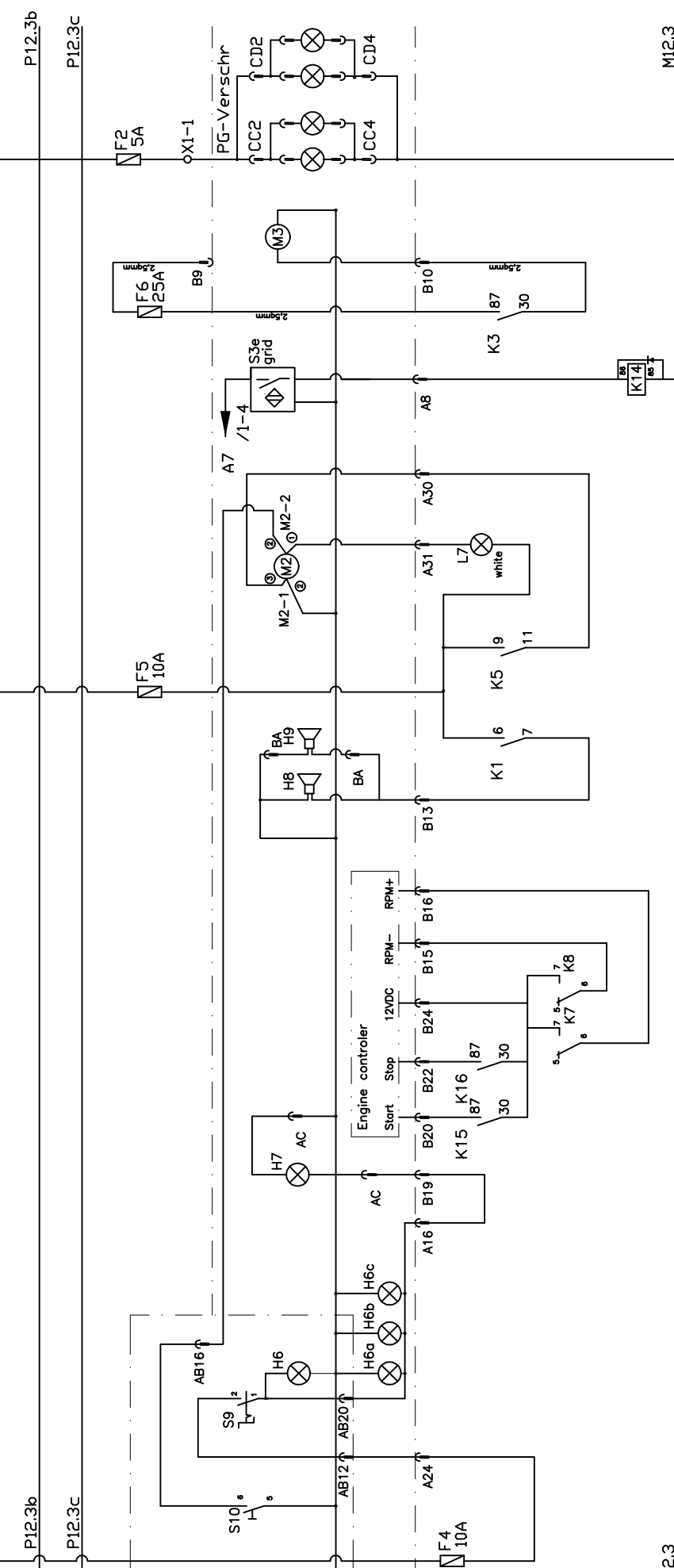

M12.3 / 2.8 Pannel Light lubrication M12.3 / 4.1 Rundumbeleuchtung optional



		SCALE	WEIGHT	
FREE DIMENSION TOLERANCE DIN 7188 MEDIUM			Seite 3	
DATE	NAME	Bedienpult		
23.03.04	Felzer			
CHKD.	APPD.			
d siehe B_513023.doc 01.06.05 Körner c siehe B_513023.doc 24.03.05 Körner b siehe B_513023.doc 01.03.05 Körner a siehe B_513023.doc 02.06.04 Körner	CHANGE ONLY WITH CAD	REPLACEMENT FOR		
ISSUE	MODIFICATION	DATE	NAME	ORIGINAL
		B 51 3 022		SHEET
				OF

THIS INFORMATION MAY NOT BE COPIED BY A THIRD PARTY. SUBJECT TO COPYRIGHT (PARA-GRAPH 1 NO. 3 OF "URheberRECHTSGESETZ" FROM 14.06.1991)

P12.4a P12.4b P12.4c P12.4d

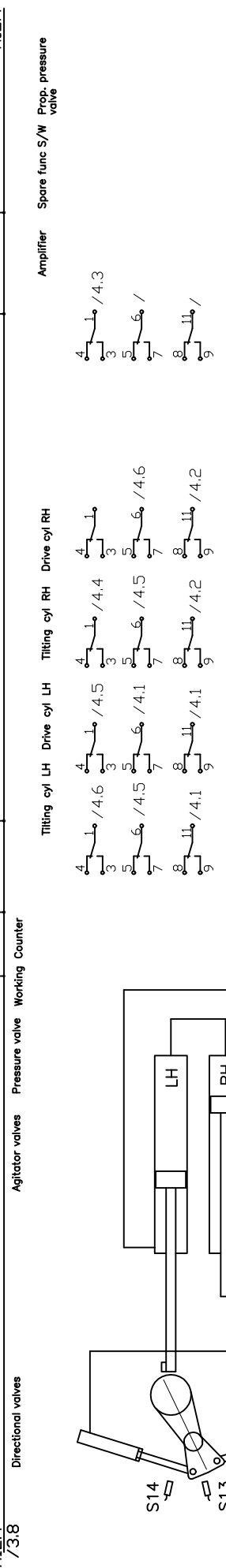
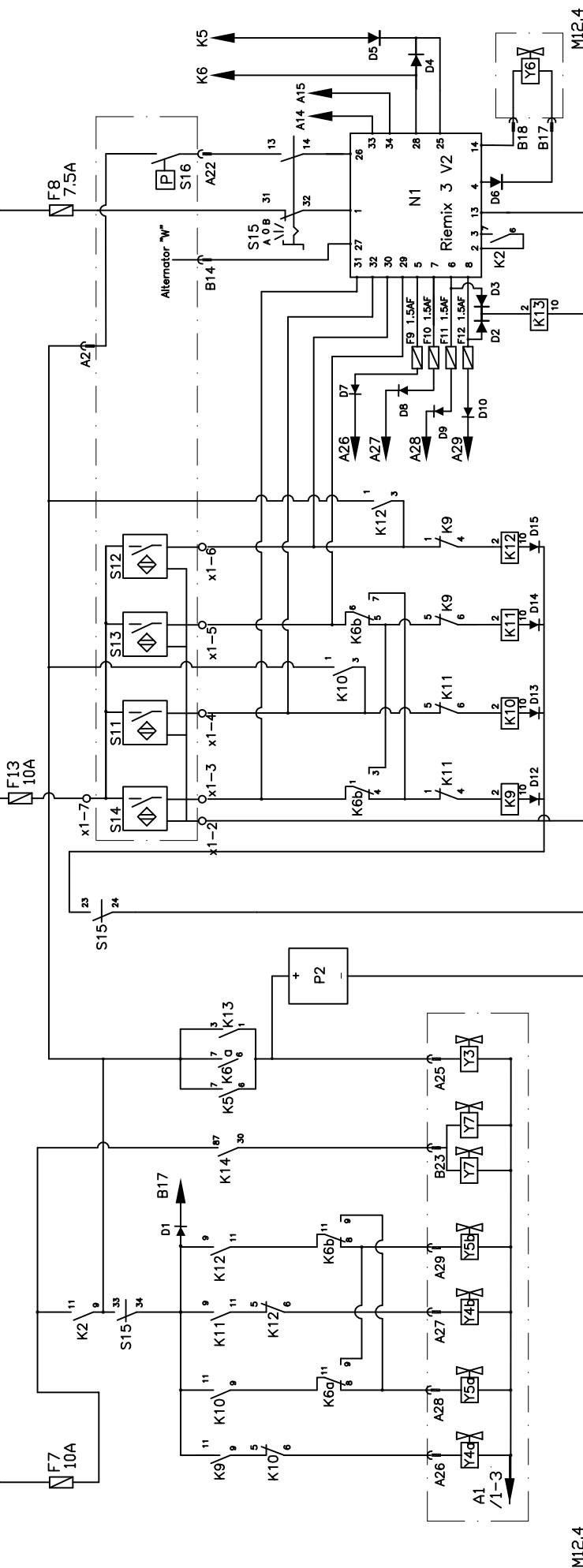

SCALE		WEIGHT	
Seite 4		Bedienpult	
FREE DIMENSION TOLERANCE DIN 7185 MEDIUM		DATE	
DRAWN 23.03.04		NAME	
CHKD.		Fetzer	
APPD.			
d siehe B_513023.doc 01.06.05 Körner		DATE	
c siehe B_513023.doc 24.03.05 Körner		NAME ORIGINAL	
b siehe B_513023.doc 01.03.05 Körner		CHANGE ONLY WITH CAD	
a siehe B_513023.doc 02.06.04 Körner		REPLACEMENT FOR	
ISSUE MODIFICATION		B 51 3 022	
		SHEET	
		OF	

THIS INFORMATION MAY NOT BE COPIED BY A THIRD PARTY. SUBJECT TO COPYRIGHT (PARAGRAPH 1 NO. 3 OF "URheberRECHTSGESETZ" FROM 14.06.1991)



Schaltschrank kpl.  
control panel cpl.

B 51 3 022d

6

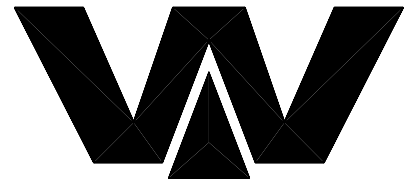

Waitzinger  
Baumaschinen GmbH

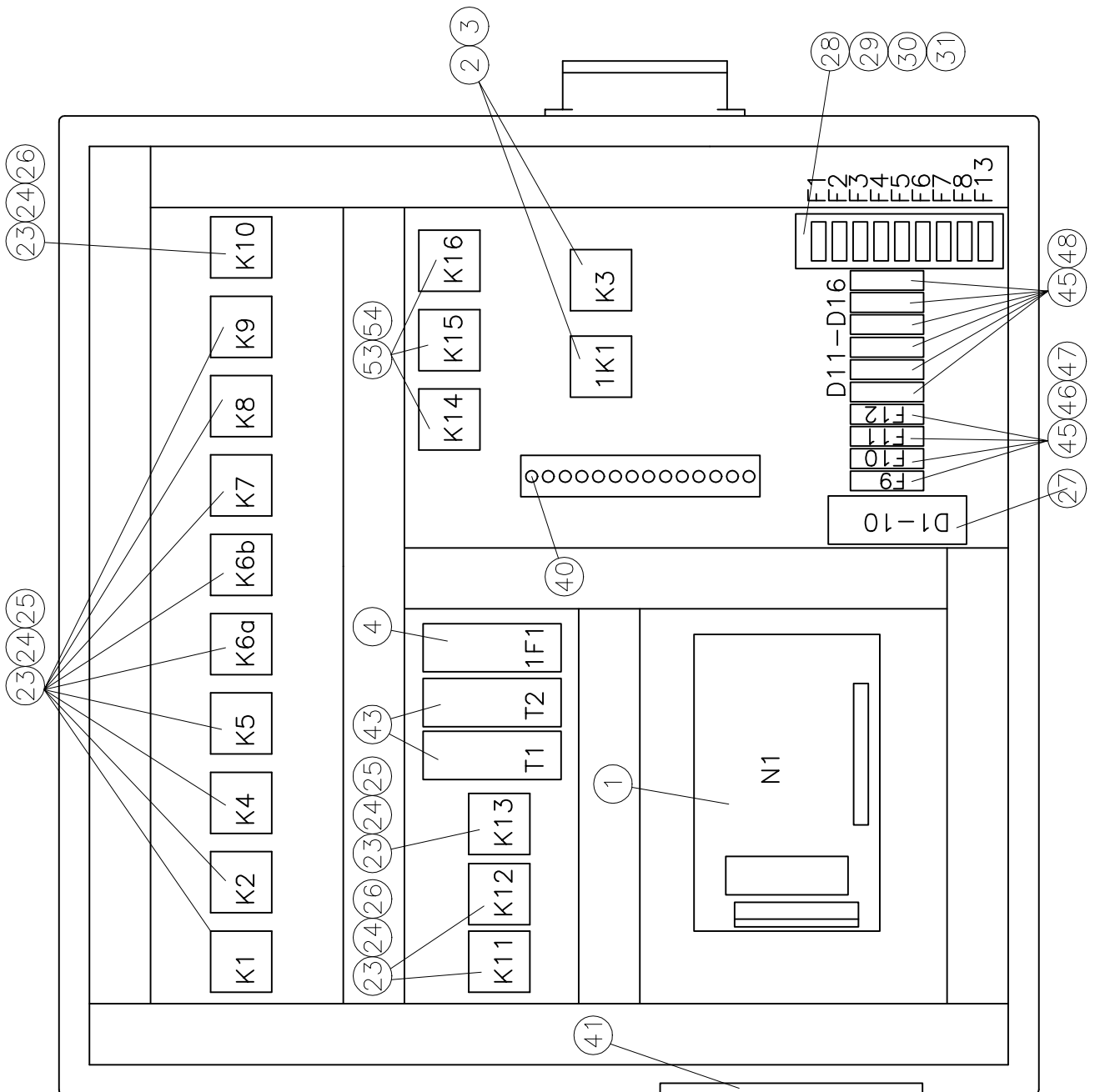

Schaltschrank kpl.  
control panel cpl.

B 51 3 022d

5

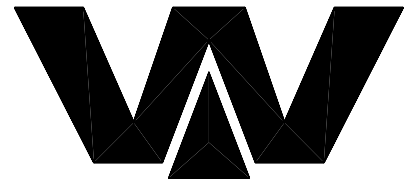

Waitzinger  
Baumaschinen GmbH

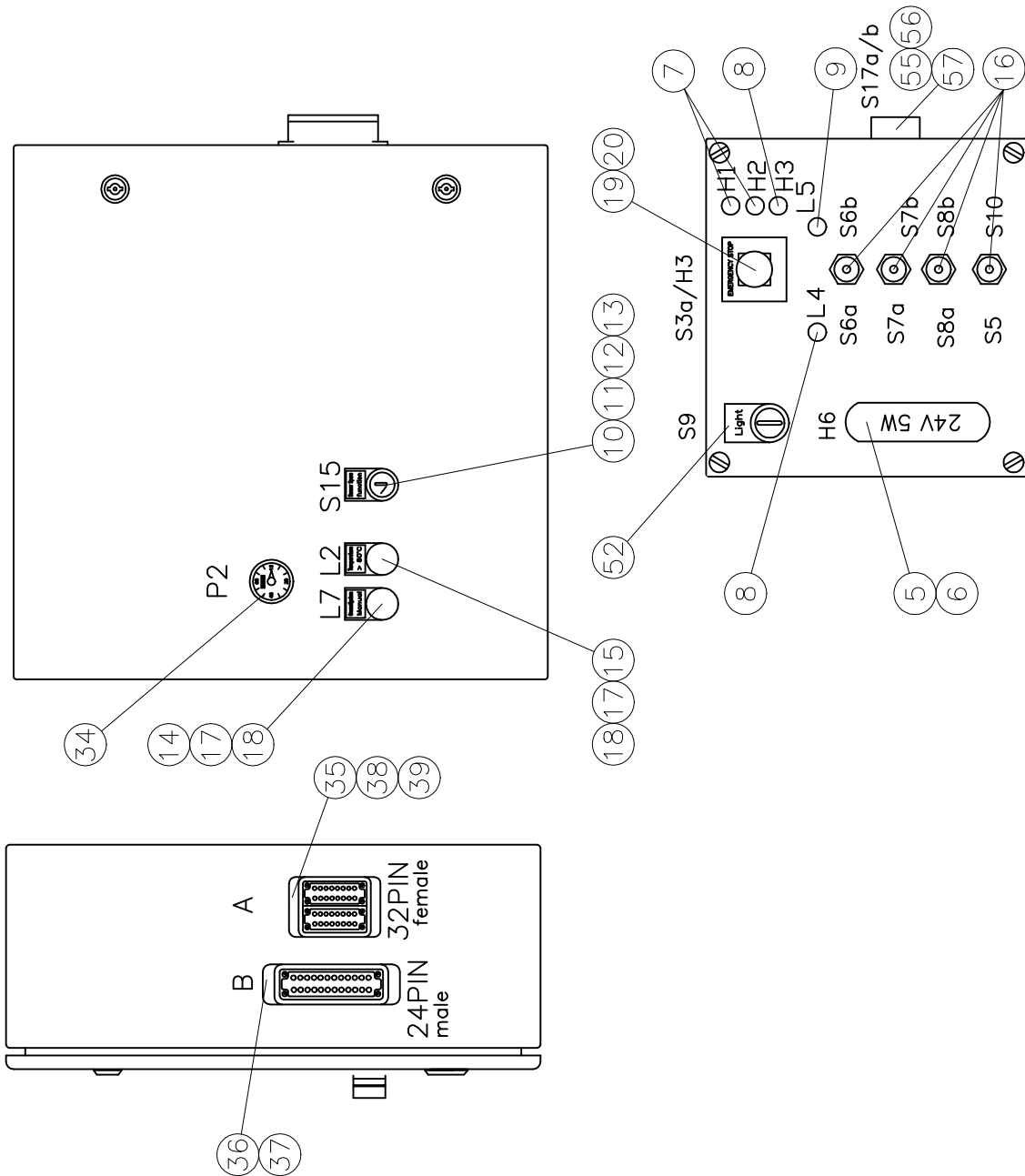



## PARTS LIST

part list	description	created	index	valid from	valid to	
b513022	control panel	21.10.04 ANDREA-	d	01.06.05		
pos	description stock	ident-no dimensions	DIN material	index	weigh Kg	quantity unit
1	amplifier riemix 3, version 4.x	WAI103330			0,22	1,00 Stk
2	relay 24VDC, 40A	WAI108252				2,00 Stk
3	socket for relay	WAI108253				2,00 Stk
4	emergency switch element PNOZ X5	WAI107414				1,00 Stk
6	bulb 24V, 5W	WAI105890				1,00 Stk
7	signal lamp, red	WAI107042				2,00 Stk
8	signal lamp, green	WAI104862				2,00 Stk
9	signal lamp, gelb	WAI108471				1,00 Stk
10	rotary button	WAI100967				1,00 Stk
11	holder	WAI100287				1,00 Stk
12	switch element	WAI100969				3,00 Stk
13	bridge	WAI103735				1,00 Stk
14	lamp RLF-WS	WAI104080				1,00 Stk
15	lamp	WAI101715				1,00 Stk
16	lever switch MOM-OFF-MOM	WAI103976				4,00 Stk
17	lamp socket BF	WAI104082				2,00 Stk
18	bulb 24V,18W	WAI106651				2,00 Stk
19	emergency switch	WAI108288			0,01	1,00 Stk
20	relay opener AK01	WAI108273				1,00 Stk
23	relay DC 24V, 11pin	WAI100183				13,00 Stk
24	clip for relay	WAI104094				13,00 Stk



## PARTS LIST

part list	description	created	index	valid from	valid to	
b513022	control panel	21.10.04 ANDREA-	d	01.06.05		
pos	description stock	ident-no dimensions	DIN material	index	weigh Kg	quantity unit
25	socket for relay	WAI106994				10,00 Stk
26	socket 11-poles	WAI104859				3,00 Stk
27	diode, D-12/3A	WAI108321				1,00 Stk
28	fuse box	WAI101577				1,00 Stk
29	fuse 5 A	WAI101922				5,00 Stk
30	fuse 7,5 A	WAI104590				1,00 Stk
31	fuse 10 A	WAI101921				2,00 Stk
34	operating hours counter	WAI100900				1,00 Stk
35	housing-body, lower part	WAI106627				1,00 Stk
36	housing-body, lower part 24-pol	WAI101533				1,00 Stk
37	plug insertion 24-pol.	WAI100714				1,00 Stk
38	plugbox insert 1-16 pol.	WAI102593				1,00 Stk
39	plugbox insert 17-32 pol.	WAI102157				1,00 Stk
40	earth terminal block	WAI102577				1,00 Stk
41	bag for circuit diagram	WAI104099				1,00 Stk
42	rubber cushion 25 x 20	WAI104100				4,00 Stk
43	relay	WAI106995				2,00 Stk
45	clamp	WAI104186				10,00 Stk
46	fuse plug	WAI104864				4,00 Stk
47	fuse 1,6 A	WAI103827				4,00 Stk
48	diode, 1A	WAI105337				6,00 Stk



## PARTS LIST

<b>part list</b>	<b>description</b>	<b>created</b>	<b>index</b>	<b>valid from</b>	<b>valid to</b>	
b513022	control panel	21.10.04 ANDREA- d		01.06.05		
<b>pos</b>	<b>description stock</b>	<b>ident-no dimensions</b>	<b>DIN material</b>	<b>index</b>	<b>weigh Kg</b>	<b>quantity unit</b>
52	button	WAI106650				1,00 Stk
53	change-over relay	WAI104930				3,00 Stk
54	relay socket	WAI100986				3,00 Stk
55	dobble pusch buttom	wai109543				1,00 Stk
56	contact	wai107146				1,00 Stk
57	switch element	wai107275				2,00 Stk





## PARTS LIST

part list	description	created	index	valid from	valid to	
B562050	cable loop truck 36mXT	21.04.04 ak	b	22.09.04		
pos	description stock	ident-no dimensions	DIN material	index	weigh Kg	quantity unit
1	cable for remote control own parts list	WAI107549				1,00 Stk
2	horn	WAI102436			0,50	1,00 Stk
3	cable loop truck own parts list	B562048				1,00 Stk
4	cable loop boom/pump own parts list	B562063		a 17.01.05		1,00 Stk
7	Balluf sensor with installation kit own parts list	B564017				2,00 Stk
9	anti-interference device	WAI102760				6,00 Stk
11	key switch	WAI107316				1,00 Stk
12	led-signal lamp, green	WAI106920				1,00 Stk
20	thermo sensor 80 degrees C, M22x1.5	WAI100130			0,06	1,00 Stk
21	rubber cushion	WAI104866				4,00 Stk
22	stop nut M8 DIN985 8. VERZ.	WAI102111			5,00	12,00 Stk
23	hexagon bolt M8 x 25 DIN 933 8.8	WAI101621				4,00 Stk
24	washer 8.4	WAI101625				12,00 Stk
25	cheese head screw M5x20 DIN 912 8.8	WAI103389				4,00 Stk
26	locking nut DIN 980	WAI102068				4,00 Stk
27	inductiv sensor BES 516-356	WAI103130			0,03	2,00 Stk
28	plug M12 + 5m cabel	WAI109055				1,00 Stk
29	angle	B561078 Bl 6x120x155	1543/EN10029 S235J2G3	a 11.07.02	0,80	2,00 Stk
30	holder	B561077 Bl 8x30x210	1543/EN10029 S235J2G3		0,30	2,00 Stk
32	plug M12 + 3m cabel	WAI105999				2,00 Stk
33	light switch	WAI104217				1,00 Stk



## PARTS LIST

part list	description	created	index	valid from	valid to	
B562050	cable loop truck 36mXT	21.04.04 ak	b	22.09.04		
pos	description stock	ident-no dimensions	DIN material	index	weigh Kg	quantity unit
34	fuse holder	WAI104204				1,00 Stk
35	plug	WAI104206				1,00 Stk
36	support	WAI104207				1,00 Stk
37	fuse 15 A	WAI104095				2,00 Stk
38	fuse 5 A	WAI101922				2,00 Stk
39	switch	WAI109027				1,00 Stk
40	plate	B564024 Bl 6x45x80	1543/EN10029 S235J2G3		0,16	1,00 Stk
41	plate	B564025 Bl 3x180x183	1543/EN10029 S235J2G3		0,16	1,00 Stk
42	cheese head screw M 4 x 30	WAI109369				4,00 Stk
43	washer 4	WAI104633				4,00 Stk
44	countersunk screw	WAI103176				2,00 Stk
45	washer 6.4	WAI101627				2,00 Stk
46	plug M12 + 5m cabel	WAI109054				1,00 Stk
47	strip	B561081 Fl 30x8x100	1017 St 37-2		0,30	1,00 Stk
48	plate	B561082 Fl 4x50x100	1017 St 37-2		0,10	1,00 Stk









## PARTS LIST

part list	description	created	index	valid from	valid to	
B562048	cable loop truck	21.04.04 Mi				
pos	description stock	ident-no dimensions	DIN material	index	weigh Kg	quantity unit
1	housing upper part, 24-pol	WAI101542				1,00 Stk
2	socket insertion 24-pol.	WAI100710				1,00 Stk
3	plug	WAI104691				2,00 Stk
4	coupling	WAI104523				1,00 Stk
5	plug housing 2-poles	WAI108701			0,00	1,00 Stk
6	locking wedge	WAI108702			0,01	1,00 Stk
7	plug	WAI104530				2,00 Stk
8	plug connection	WAI108703				2,00 Stk
9	cap	WAI108704				1,00 Stk
10	fitting PG21	WAI104507				1,00 Stk
11	fitting PG9	WAI104506				4,00 Stk
14	t - piece 22-10-22	WAI105263				7,00 Stk
15	t - piece 10-10-10	WAI104514				3,00 Stk
16	housing	WAI106263				1,00 Stk
18	cap	WAI104513				2,00 Stk
20	sealing for cable fitting PG21	WAI104697				1,00 Stk
21	sealing for cable fitting PG9	WAI104695				4,00 Stk
22	O-ring 15 x 1,5	WAI104701				1,00 Stk
23	O-ring 8.9 x 1.25	WAI104700				4,00 Stk
24	flat plug sleeve 2,5mm	WAI104785				4,00 Stk
28	cove end sleeve 2.5mm	WAI101997				20,00 Stk



## PARTS LIST

part list	description	created	index	valid from	valid to	
B562048	cable loop truck	21.04.04 Mi				
pos	description stock	ident-no dimensions	DIN material	index	weigh Kg	quantity unit
29	cove end sleeve 1.5mm	WAI101996				20,00 Stk
30	cove end sleeve 1.5mm	WAI104692				20,00 Stk
32	shrink hose	WAI104677				0,10 Mtr
33	cable tie 200x3.6, black	WAI103137				100,00 Stk
34	plug housing male	WAI105865				1,00 Stk
35	plug housing female	WAI105866				1,00 Stk
36	plug housing adaptor to cable pipe	WAI105867				2,00 Stk
37	plug housing sealing	WAI105868				4,00 Stk
38	plug insert female 2,5 mm D	WAI105869				2,00 Stk
39	plug insert male	WAI105870				2,00 Stk
41	cable pipe	WAI104213				23,00 Mtr
42	cable 1 qmm, brown	WAI104195				16,00 Mtr
43	cable 1 qmm, green	WAI104202				17,00 Mtr
44	cable 1.5 qmm, red - yellow	WAI104575				6,00 Mtr
45	cable 1.5 qmm, yellow - white	WAI104574				13,00 Mtr
46	cable 1.5 qmm, green - white	WAI104569				8,54 Mtr
47	cable 1.5 qmm, blue	WAI104654				11,00 Mtr
48	cable 1.5 qmm, black	WAI104655				11,00 Mtr
49	cable 1.5 qmm, black - green	WAI104572				8,00 Mtr
50	cable 1.5 qmm, black - red	WAI104570				8,00 Mtr
51	cable 1.5 qmm, grey - red	WAI104567				14,00 Mtr



# PARTS LIST

part list	description	created	index	valid from	valid to	
B562048	cable loop truck	21.04.04 Mi				
pos	description stock	ident-no dimensions	DIN material	index	weigh Kg	quantity unit
52	cable 1.5 qmm, violet	WAI104565				12,00 Mtr
53	cable 1 qmm, grey - brown	WAI105535				20,00 Mtr
54	cable 1.5 qmm, black - white	WAI104573				7,00 Mtr
55	cable 1 qmm, white	WAI104200				17,00 Mtr
56	cable pipe	WAI104520				12,00 Mtr
57	cable 1.5 qmm, blue - white	WAI104571				7,00 Mtr
60	cable 2,5 qmm, brown	WAI104198				44,00 Mtr
61	cable 2,5 qmm, black	WAI104652				13,50 Mtr
62	cable 2,5 qmm, blue	WAI104197				33,00 Mtr
63	cable 2,5 qmm, red	WAI105660				15,00 Mtr

*Kabelbaum Mast/Pumpe kpl.*  
*cable loop boom/pump cpl.*

*B 56 2 063a*

*1*

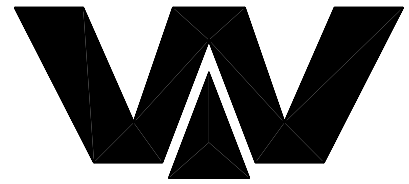

Waitzinger  
 Baumaschinen GmbH

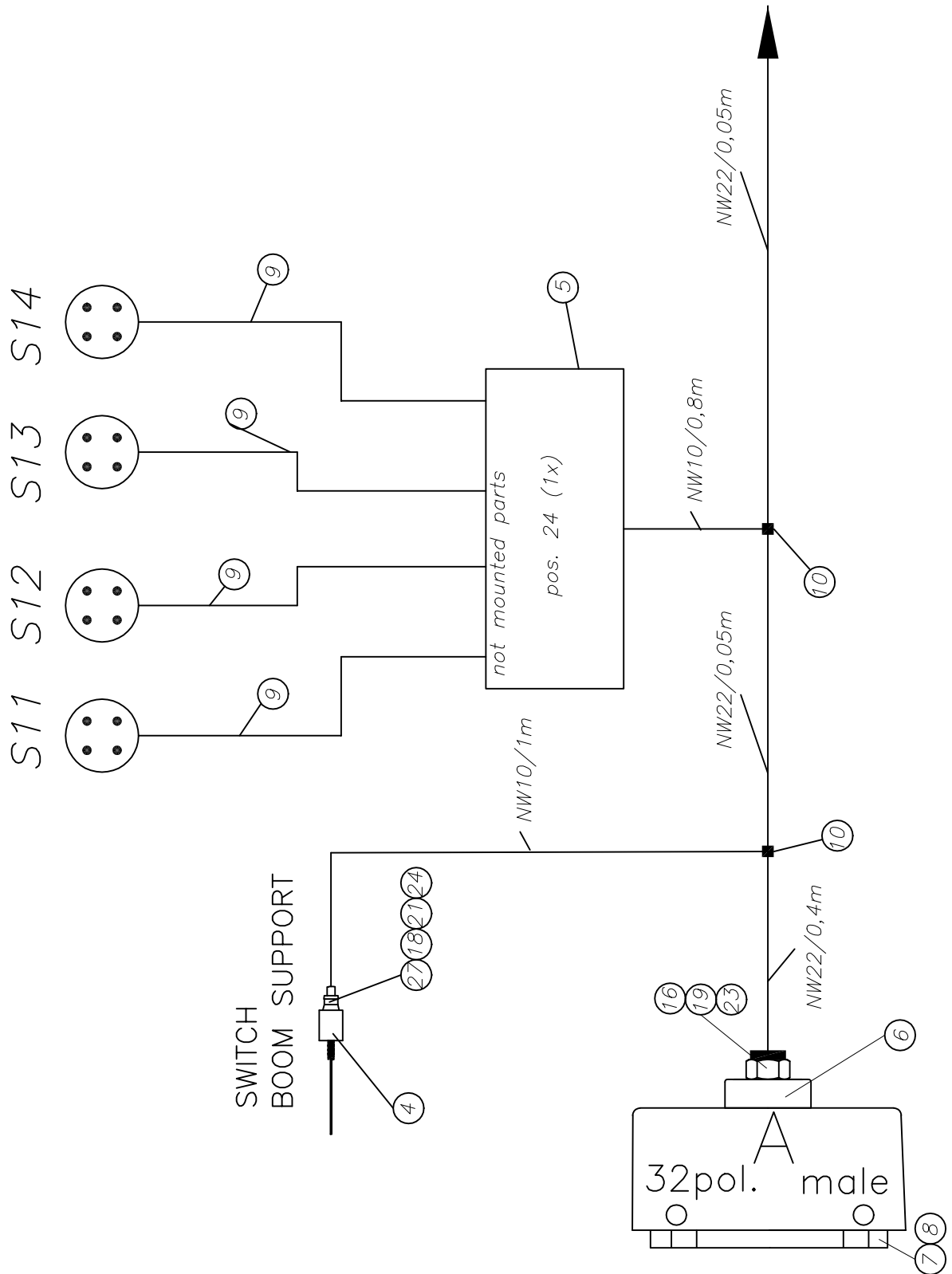

*Kabelbaum Mast/Pumpe kpl.  
cable loop boom/pump cpl.*

*B 56 2 063a*

*2*

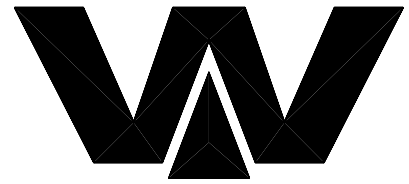

*Waitzinger  
Baumaschinen GmbH*

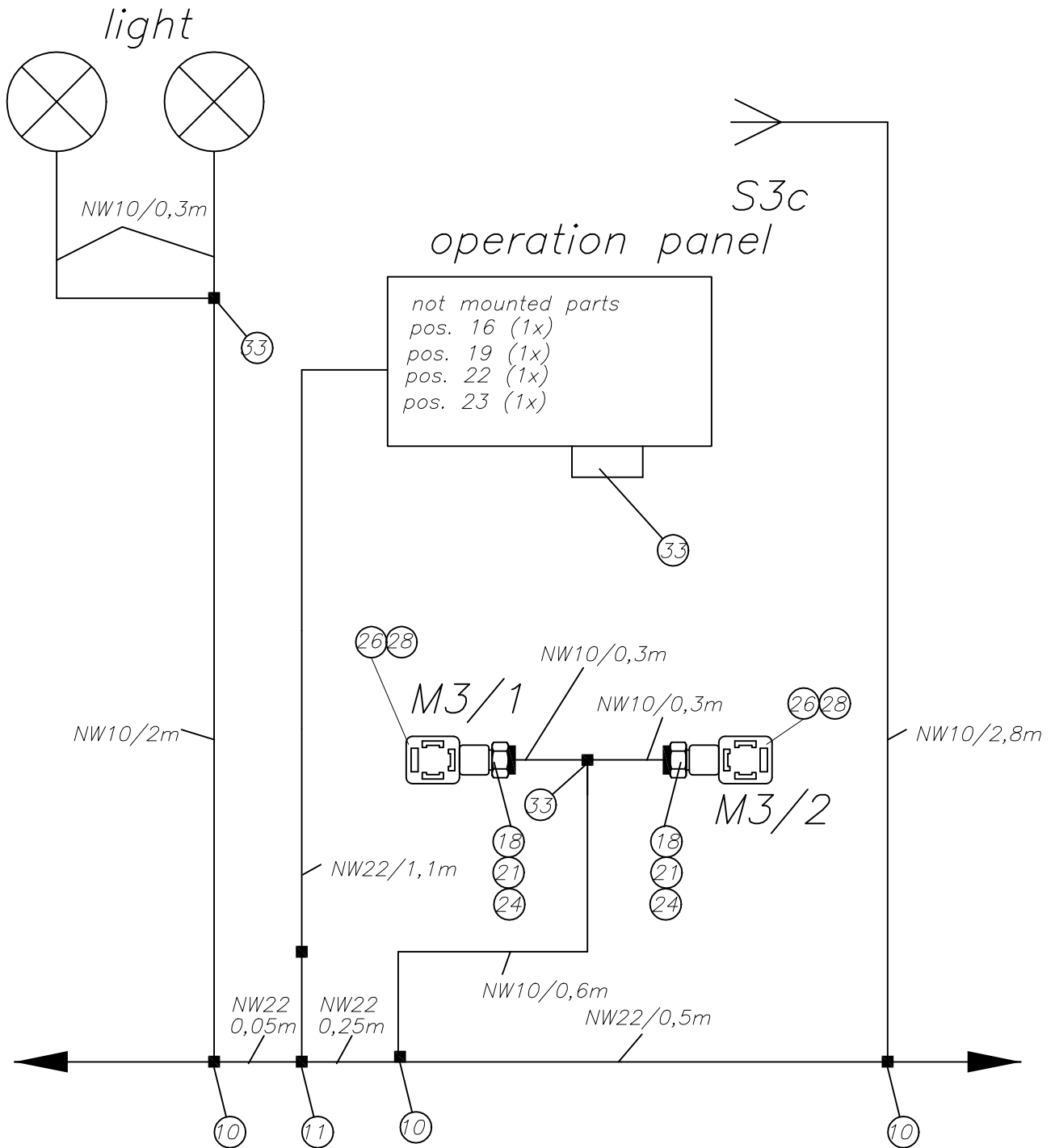

*Kabelbaum Mast/Pumpe kpl.*  
*cable loop boom/pump cpl.*

**B 56 2 063a**

**3**

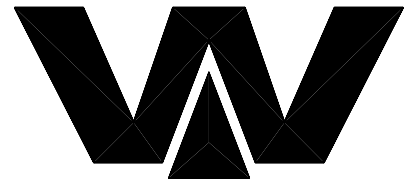

Waitzinger  
 Baumaschinen GmbH

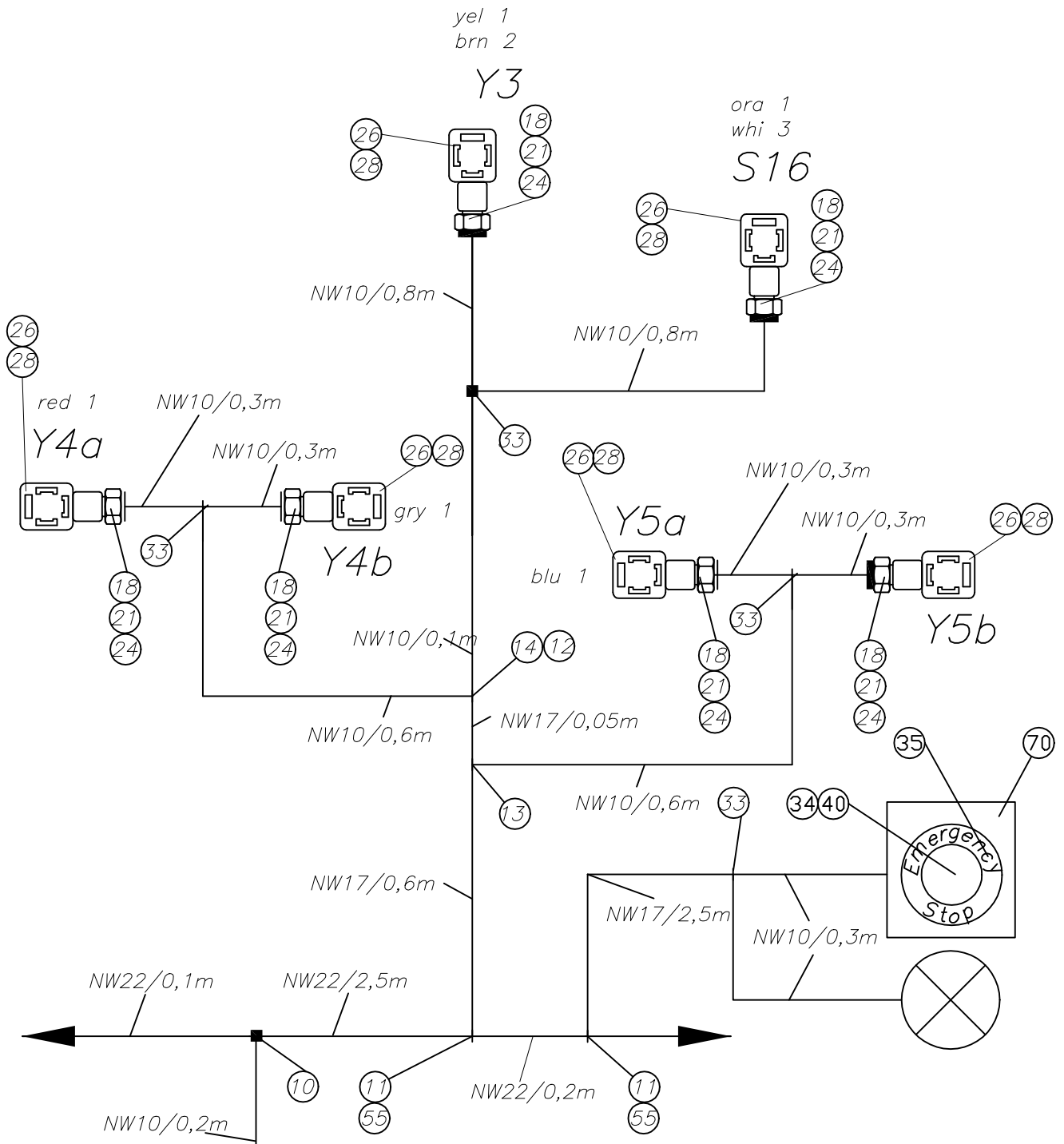



*Kabelbaum Mast/Pumpe kpl.  
cable loop boom/pump cpl.*

*B 56 2 063a*

4

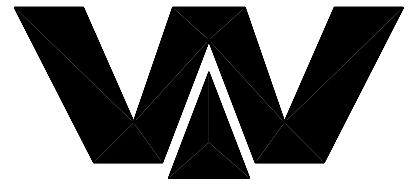

Waitzinger  
Baumaschinen GmbH

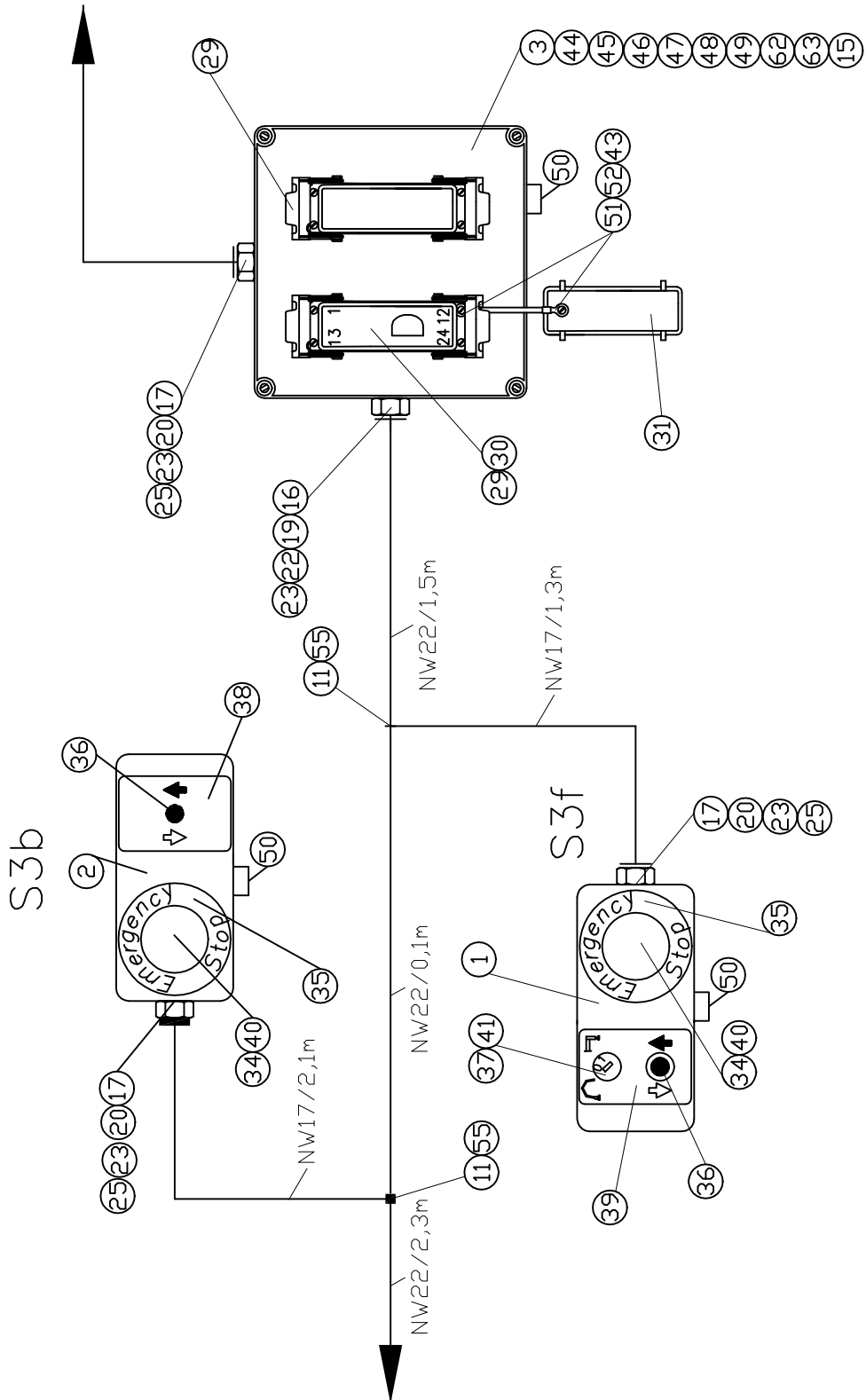



*Kabelbaum Mast/Pumpe kpl.*  
*cable loop boom/pump cpl.*

**B 56 2 063a**

**6**

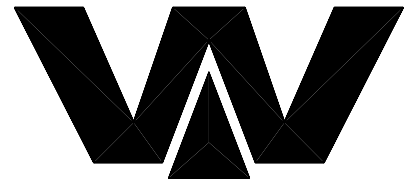

Waitzinger  
Baumaschinen GmbH

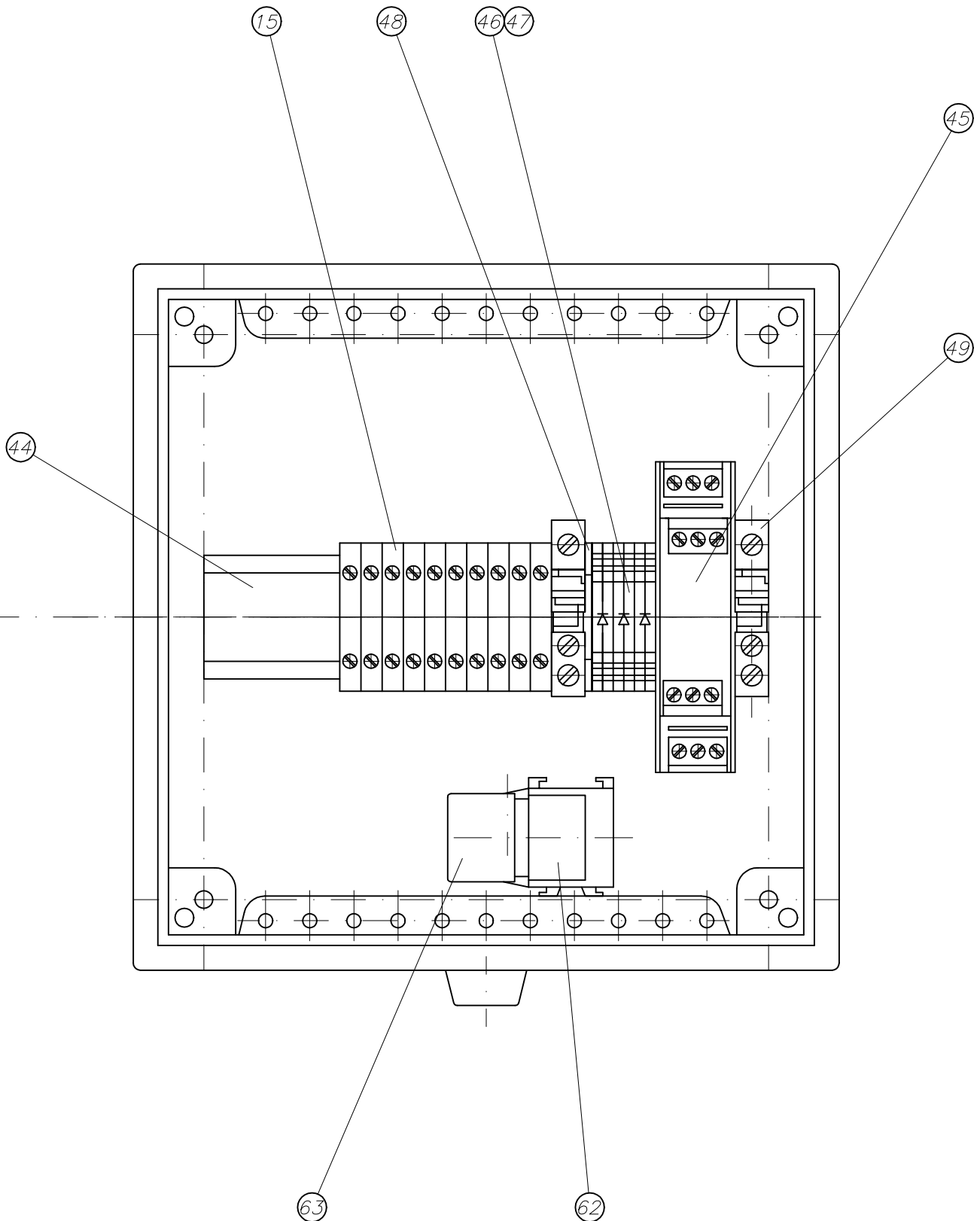



## PARTS LIST

part list	description	created	index	valid from	valid to	
b562063	cable loop boom/pump	21.09.04 ALEXAND	a	17.01.05		
pos	description stock	ident-no dimensions	DIN material	index	weigh Kg	quantity unit
1	housing right own parts list	B561039				1,00 Stk
2	housing left own parts list	B561043		a 25.02.02		1,00 Stk
3	Clamp box for boom own parts list	B561029		a 15.01.02		1,00 Stk
4	position switch	WAI105710				1,00 Stk
5	distributor system	WAI105998				1,00 Stk
6	housing PG 21	WAI105916				1,00 Stk
7	plug insert 1-16 pol. CDAM 16	WAI102485				1,00 Stk
8	plug insertion 17-32 pol. CDAM 16N	WAI102492				1,00 Stk
10	t - piece 22-10-22	WAI105263				6,00 Stk
11	t - piece 22-22-22	WAI104515				5,00 Stk
12	reducer	WAI104512				2,00 Stk
13	t - piece 17-10-17	WAI104332				5,00 Stk
14	t - piece	WAI104511				2,00 Stk
15	clamp	WAI104671				3,00 Stk
16	fitting PG21	WAI104507				3,00 Stk
17	fitting PG16	WAI104510				4,00 Stk
18	fitting PG9	WAI104506				17,00 Stk
19	sealing for cable fitting PG21	WAI104697				3,00 Stk
20	sealing for cable fitting PG16	WAI104696				3,00 Stk
21	sealing for cable fitting PG9	WAI104695				17,00 Stk
22	lock nut PG21	WAI104114				2,00 Stk



## PARTS LIST

part list	description	created	index	valid from	valid to	
b562063	cable loop boom/pump	21.09.04 ALEXAND a		17.01.05		
pos	description stock	ident-no dimensions	DIN material	index	weigh Kg	quantity unit
23	O-ring 15 x 1,5	WAI104701				7,00 Stk
24	O-ring 8.9 x 1.25	WAI104700				17,00 Stk
25	nut CE 16	WAI104519				4,00 Stk
26	plate	WAI104735				14,00 Stk
27	reduc. ring PG11 - 9	WAI104682				1,00 Stk
28	plug	WAI104691				14,00 Stk
29	housing-body, lower part 24-pol	WAI101533				2,00 Stk
30	socket insertion 24-pol.	WAI100710				1,00 Stk
31	protective cap	WAI101305				1,00 Stk
32	reduc. ring PG13,5 - 9	WAI104683				1,00 Stk
33	t - piece 10-10-10	WAI104514				5,00 Stk
34	emergency stop switch	WAI105094				3,00 Stk
35	label ZB2-BY9330	WAI102278				3,00 Stk
36	push button	WAI100569				2,00 Stk
37	key switch	WAI107316				1,00 Stk
38	sign plate for outrigger	WAI104770				1,00 Stk
39	sign plate for outrigger + key switch	WAI104771				1,00 Stk
40	relay opener AK01	WAI108273				1,00 Stk
41	switch element	WAI107275				2,00 Stk
43	washer 4	WAI104633				9,00 Stk
44	rail	WAI104772				0,10 Mtr



## PARTS LIST

part list	description	created	index	valid from	valid to	
b562063	cable loop boom/pump	21.09.04 ALEXAND a		17.01.05		
pos	description stock	ident-no dimensions	DIN material	index	weigh Kg	quantity unit
45	diode, MKS-D10	WAI104541				1,00 Stk
46	clamp	WAI104186				1,00 Stk
47	plug with diode	WAI104185				1,00 Stk
48	end plate	WAI104833				1,00 Stk
49	clamp	WAI104672				2,00 Stk
50	condenser	WAI104669				4,00 Stk
51	hexagon bolt M 4 x 12	WAI104632				9,00 Stk
52	hex. nut M4	WAI104634				9,00 Stk
53	cove end sleeve 1.5mm	WAI101996				70,00 Stk
54	cove end sleeve 1.5mm	WAI104692				45,00 Stk
55	reducer 22/17	WAI104509				4,00 Stk
56	cable pipe	WAI104520				12,00 Mtr
57	cable pipe	WAI104216				9,00 Mtr
58	cable pipe	WAI104213				22,00 Mtr
59	cable tie 200x3.6, black	WAI103137				150,00 Stk
61	flat plug sleeve 2,5mm	WAI104785				10,00 Stk
62	relay socket	WAI100986				1,00 Stk
63	relay	WAI107302				1,00 Stk
65	plug housing 3-poles	WAI106104				1,00 Stk
66	plug 3-poles	WAI106106				1,00 Stk
67	sealing	WAI106109				6,00 Stk



## PARTS LIST

<b>part list</b>	<b>description</b>	<b>created</b>	<b>index</b>	<b>valid from</b>	<b>valid to</b>	
b562063	cable loop boom/pump	21.09.04 ALEXAND a		17.01.05		
<b>pos</b>	<b>description stock</b>	<b>ident-no dimensions</b>	<b>DIN material</b>	<b>index</b>	<b>weigh Kg</b>	<b>quantity unit</b>
68	plug contact female	WAI106107				3,00 Stk
70	cover	WAI107300				1,00 Stk
71	contact block	WAI105095				3,00 Stk
72	lamp 24V	WAI101731				3,00 Stk
101	plate	WAI106435				10,00 Stk
102	cable	WAI108059				390,00 Mtr

*Schaltboxbefestigung kpl.*  
*switchbox mounting cpl.*

*B 56 1 050*

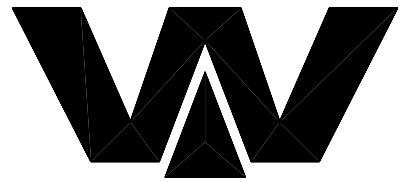

Waitzinger  
Baumaschinen GmbH

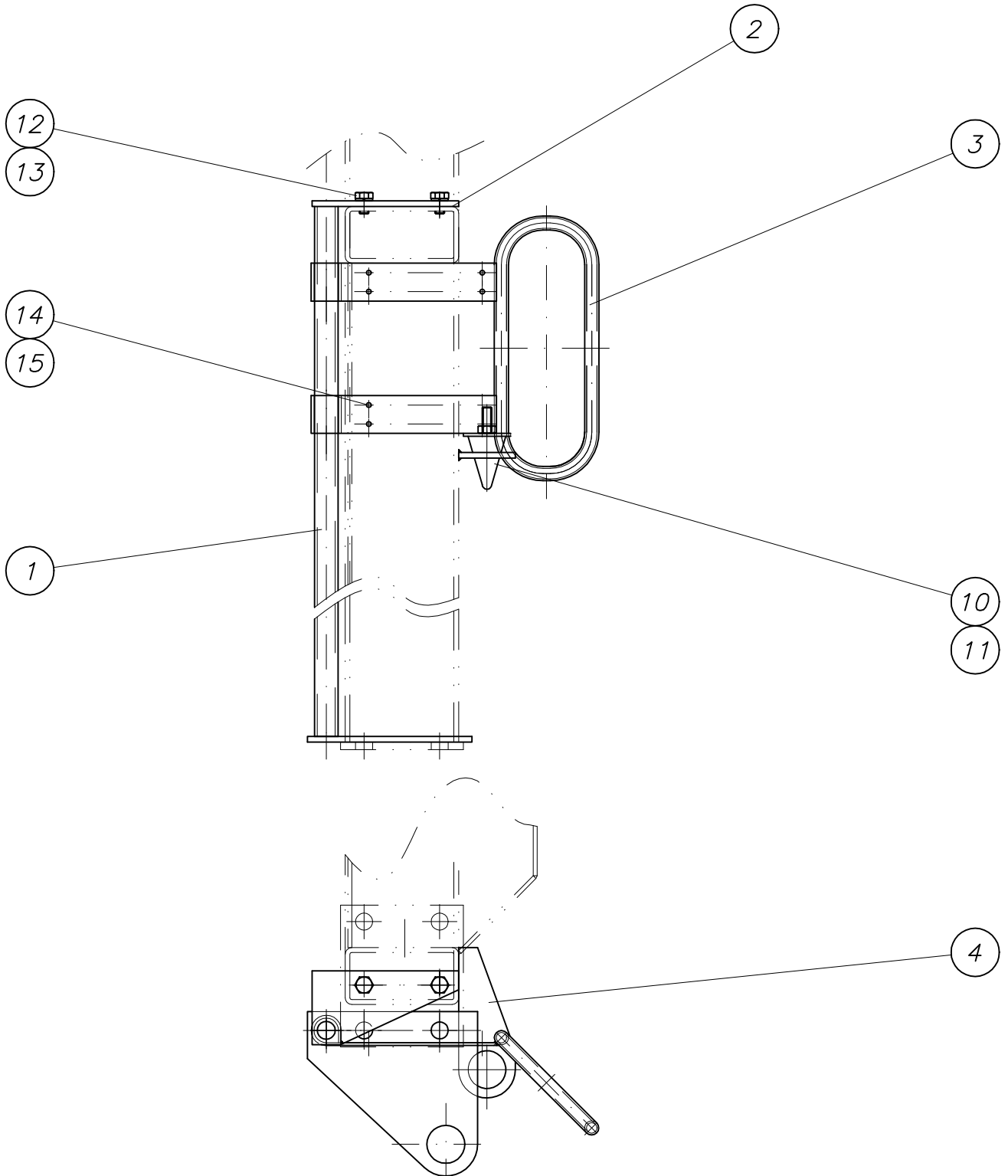





## PARTS LIST

part list	description	created	index	valid from	valid to	
B561050	switchbox mounting cpl.	04.02.99 Mi				
pos	description stock	ident-no dimensions	DIN material	index	weight Kg	quantity unit
1	holder cpl. own parts list	B561051			3,00	1,00 Stk
2	cover cpl. own parts list	B561052			0,40	1,00 Stk
3	handle cpl. own parts list	B561053		a 24.02.05	1,00	1,00 Stk
4	fixing sheet	B561054 Bl 6x60x159	1543/EN10029 St37-2		0,20	1,00 Stk
10	rubber buffer 50 x 58	WAI102712				1,00 Stk
11	nut M10 DIN 934	WAI101556			0,01	1,00 Stk
12	hexagon bolt M10 x 16	WAI102886				2,00 Stk
13	spring washer A10	WAI102070			0,00	2,00 Stk
14	hexagon bolt M 5 x 10	WAI103308				4,00 Stk
15	locking nut DIN 980	WAI102068				4,00 Stk

*Übersicht B 60 - B 69*

*over view B 60 - B 69*

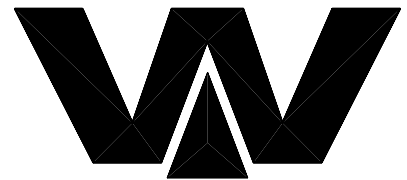

*Waitzinger  
Baumaschinen GmbH*

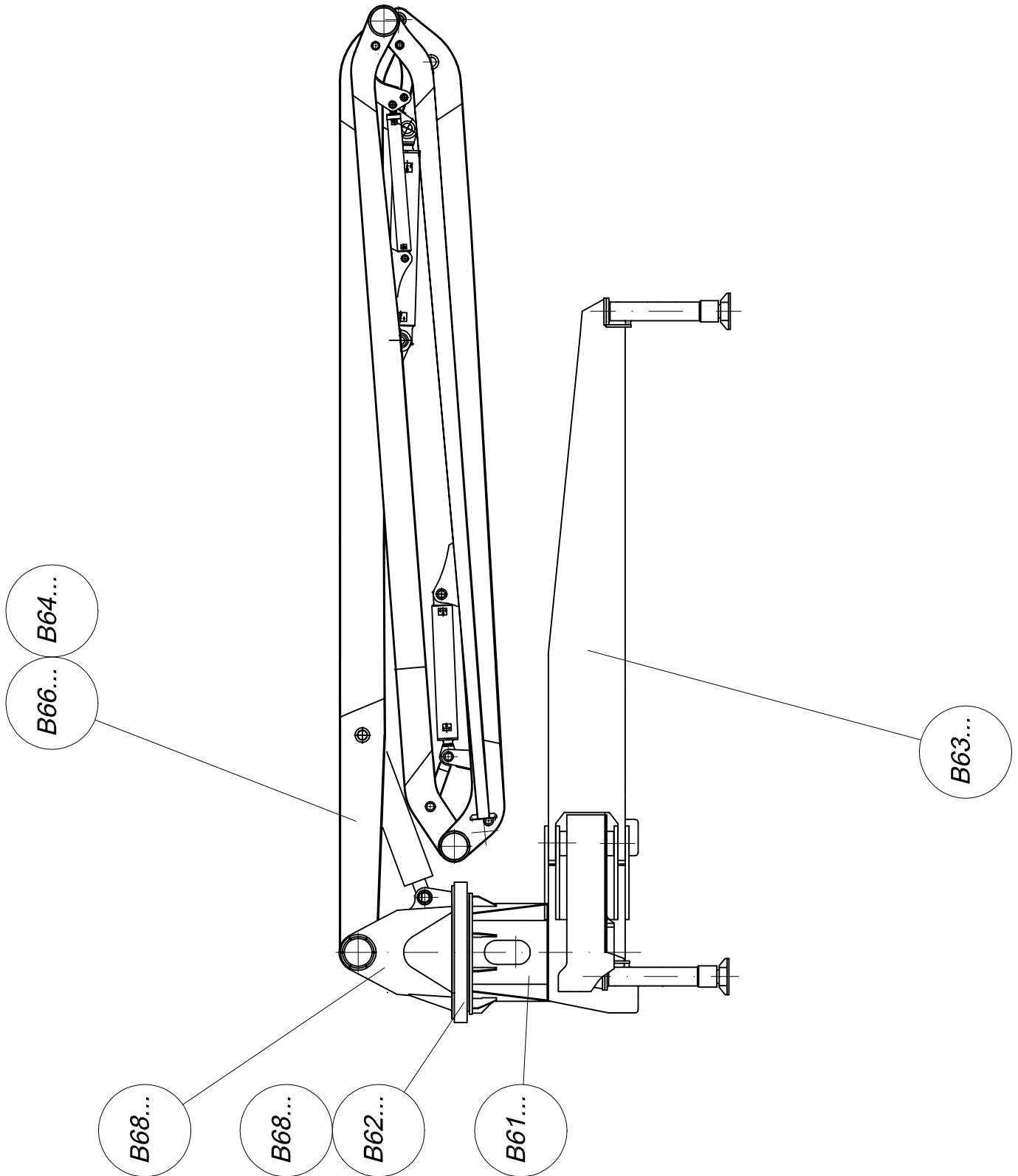

*Mastbock 36 XT kpl.  
boom base 36 XT cpl.*

*B 61 8 110*

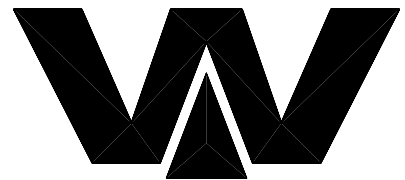

*Waitzinger  
Baumaschinen GmbH*

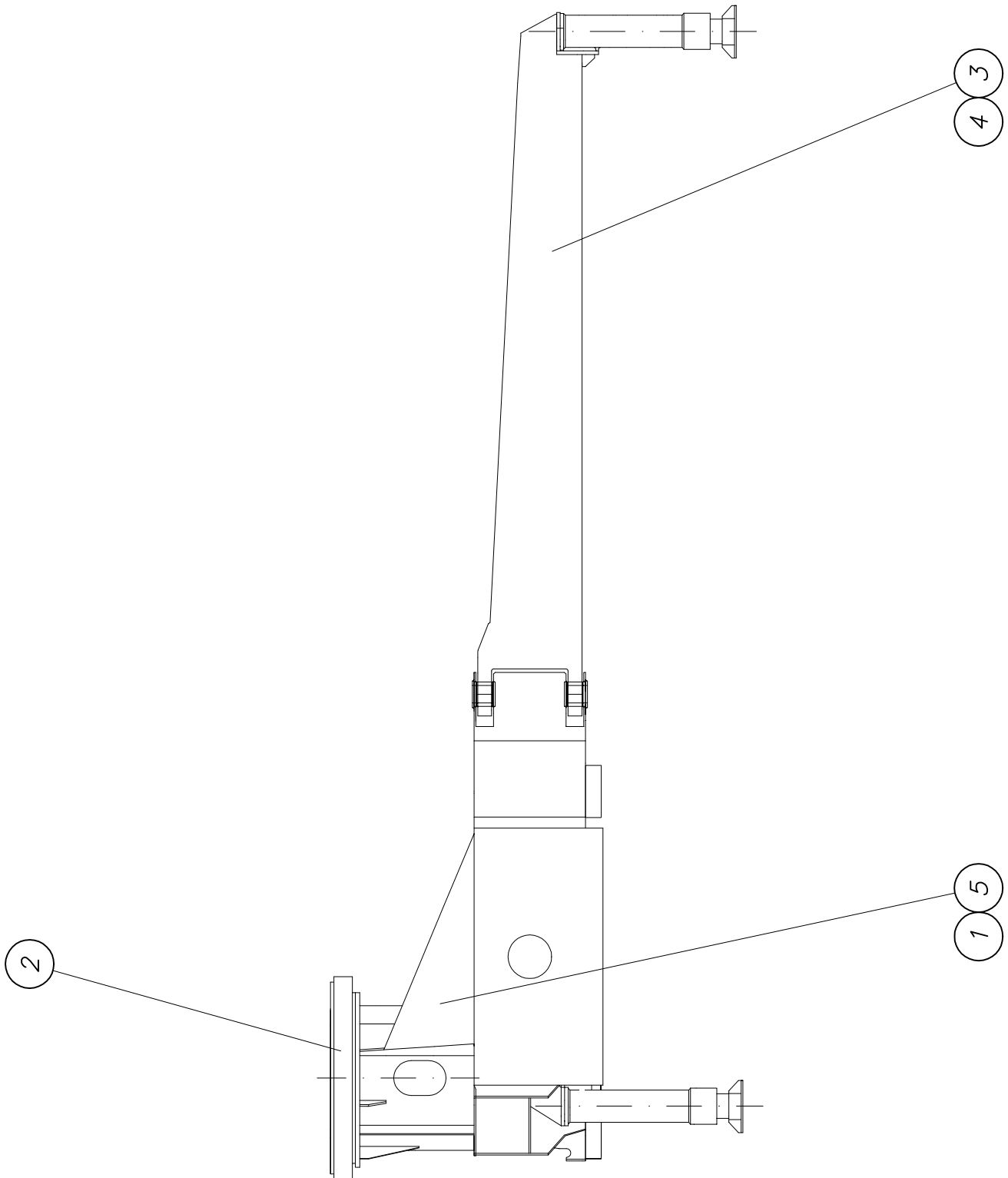



## PARTS LIST

<b>part list</b>	<b>description</b>	<b>created</b>	<b>index</b>	<b>valid from</b>	<b>valid to</b>	
B618110	pedestal 36 Xt for type list	20.04.04 hbk				
<b>pos</b>	<b>description stock</b>	<b>ident-no dimensions</b>	<b>DIN material</b>	<b>index</b>	<b>weigh Kg</b>	<b>quantity unit</b>
1	pedestal 36 X cpl own parts list	B618010		c 30.06.04		1,00 Stk
2	turning unit cpl. own parts list	B628010				1,00 Stk
3	outrigger 36 X cpl own parts list	B638010				1,00 Stk
4	pipig diagram 36 XT boom base with Rab own parts list	B728015		a 16.02.05		1,00 Stk
5	hydr. system boom 36m XT cpl. own parts list	B718001				1,00 Stk

Mastbock kpl.  
boom base cpl.

B 61 8 010c

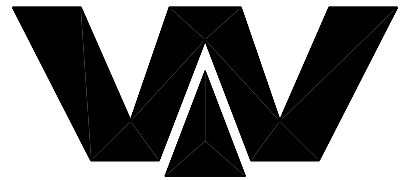

Waitzinger  
Baumaschinen GmbH

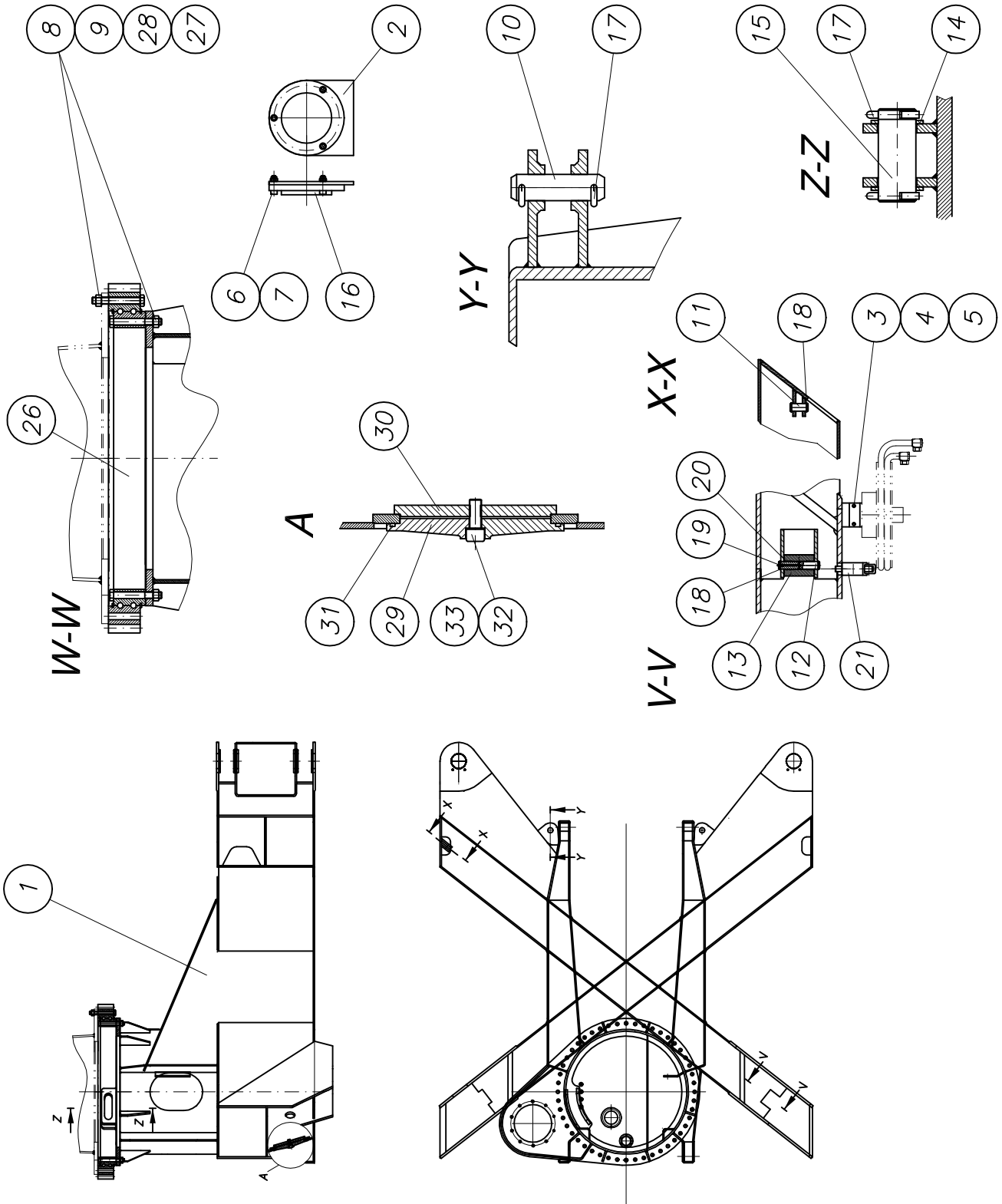



## PARTS LIST

part list	description	created	index	valid from	valid to	
B618010	pedestal 36 X cpl	26.06.00 hbk	c	30.06.04		
pos	description stock	ident-no dimensions	DIN material	index	weigh Kg	quantity unit
1	pedestal 36 X tooling own parts list	B618020			1860,00	1,00 Stk
2	holder for can drag and fly	B619093 Bl 5x100x112.5	1543/EN10029 S235J2G3	a 13.02.03	0,22	2,00 Stk
3	hexagon bolt M 20 x 50	WAI101706				4,00 Stk
4	nut M20 DIN 934	WAI102891				4,00 Stk
5	spring washer	WAI103314			0,00	4,00 Stk
6	cheese head screw M5x20 DIN 912 8.8	WAI103389				6,00 Stk
7	locking nut DIN 980	WAI102068				6,00 Stk
8	washer HV DIN 6916 23 C45	WAI101566				66,00 Stk
9	washer HV 6916 21 C45 tooled	WAI107180			0,01	30,00 Stk
10	pin 35 x 124	B610020 Rd 40 x 130	1013 C40		1,00	2,00 Stk
11	pin 25 x 060	B610021 Rd 25 x 65	669 St50-2K		0,25	2,00 Stk
12	pin 25 x 136, 3P206	B610023 Rd 25 x 140	669 St50-2K		0,50	2,00 Stk
13	roller 70 x 100, 2H105	B610024 Rd 70 x 105	669 St50-2K		2,50	2,00 Stk
14	spacer ring RD 70X 4.5	B610025 Rd 70 x 4.5	1013 S235JR		0,10	2,00 Stk
15	pin 50 x 128	B610022 Rd 55 x 130	1013 39NiCrMo3/b	a 03.08.04	1,90	1,00 Stk
16	box level d80	WAI106237				2,00 Stk
17	split pin 8 x 63 VERZ. DIN 94	WAI102875				6,00 Stk
18	locking ring A 25 X 1.2 DIN 471	WAI103006				8,00 Stk
19	grease nipple M6 DIN 71412	WAI103355				2,00 Stk
20	bushing CD025-028025	WAI105017				4,00 Stk
21	locking bolt	WAI103032				2,00 Stk



## PARTS LIST

part list	description	created	index	valid from	valid to	
B618010	pedestal 36 X cpl	26.06.00 hbk	c	30.06.04		
pos	description stock	ident-no dimensions	DIN material	index	weigh Kg	quantity unit
26	rotation bearing	WAI106168			300,00	1,00 Stk
27	hexagon bolt M 22 x 160	WAI105029				96,00 Stk
28	nut M22 DIN 934 10.	WAI104827				96,00 Stk
29	cover for oiltank D236 X 27 36XT	B610033 RD 240x30	1747 Al99		1,80	1,00 Stk
30	star for oilcover FL 15X 220X 220	B610034 FI 220x220x15	1017 S235JR	a 12.02.03	2,00	1,00 Stk
31	O-ring 217x5, No. A0120.371	WAI106011				1,00 Stk
32	u-seal 16,7 x 24 x 1,5T	WAI101572				1,00 Stk
33	cheese head screw M 16 x 55	WAI104550				1,00 Stk

*Drehwerk kpl.  
turning unit cpl.*

*B 62 8 010*

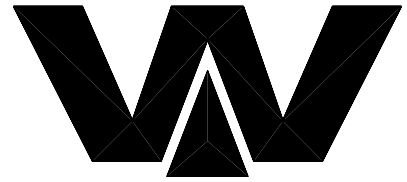

*Waitzinger  
Baumaschinen GmbH*

- ① *Drehwerkseinheit kpl.  
turning unit cpl.  
B 62 8 011a*
- ② *Schutzeinrichtung kpl.  
protection unit cpl.  
B 62 8 012c*



*Drehwerkseinheit kpl.*

*turning unit cpl.*

**B 62 8 011a**

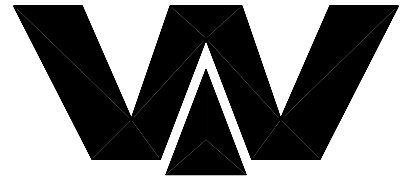

Waitzinger  
Baumaschinen GmbH

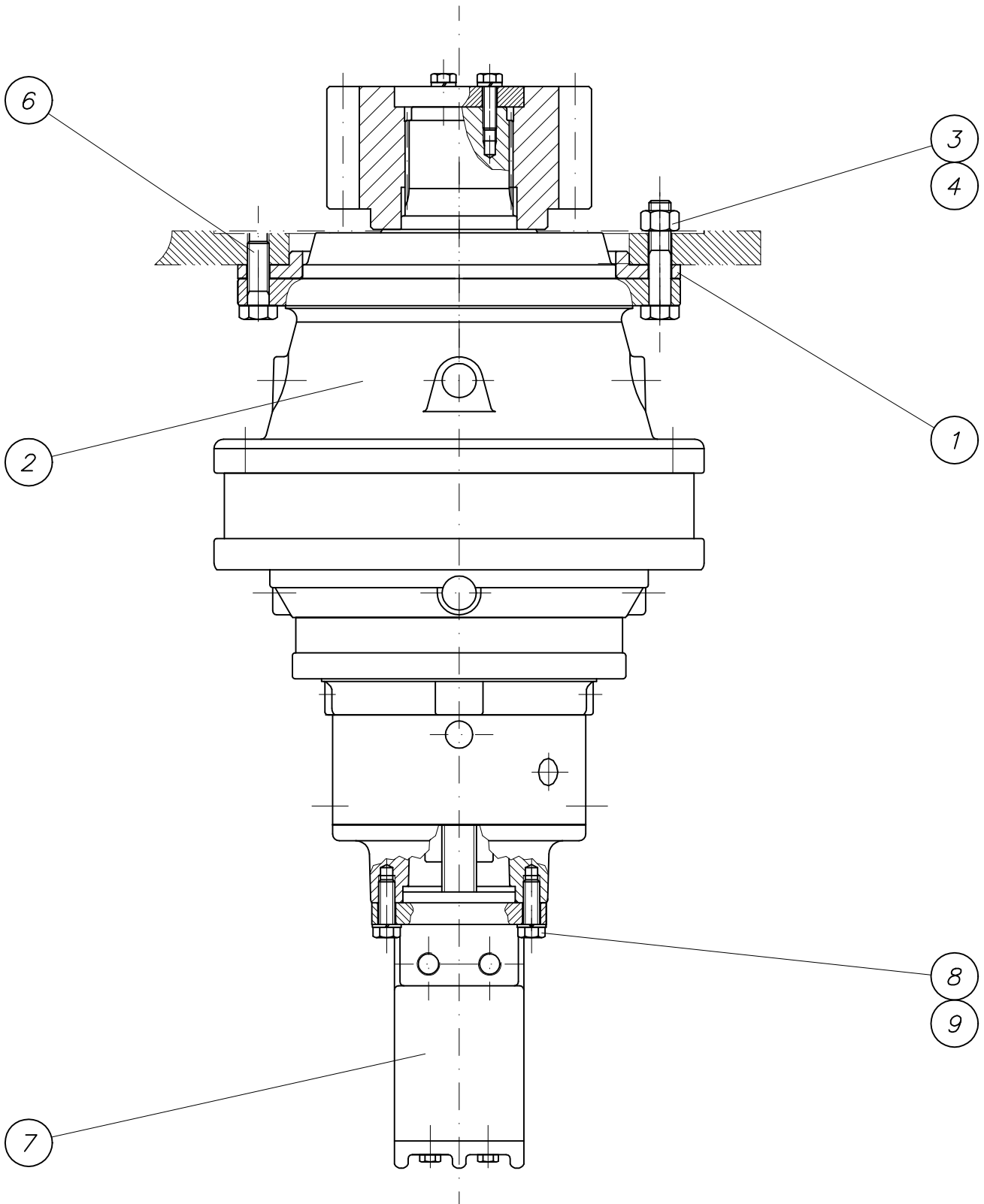



## PARTS LIST

part list	description	created	index	valid from	valid to	
B628011	turning unit cpl.36XT AND 36ST	27.06.00 hbk	a	17.06.04		
pos	description stock	ident-no dimensions	DIN material	index	weigh Kg	quantity unit
1	eccentric flange for turning unit	B620049 Rohr 323.9 x 50	2448 S355JR	a 04.01.01	3,60	1,00 Stk
2	gearbox PG1602-MFS SOM own parts list	WAI106266			151,60	1,00 Stk
3	hexagon bolt M16 x 80	WAI106268			0,17	7,00 Stk
4	nut M16 DIN 934	WAI101555				7,00 Stk
6	hexagon bolt M16 x 50	WAI106269			0,17	3,00 Stk
7	hydraulic motor Char Lynn	WAI106301				1,00 Stk
8	hexagon bolt M12 x 35	WAI102122			0,04	2,00 Stk
9	spring washer A12 DIN 127 VERZ.	WAI102896				2,00 Stk

*Drehwerksgetriebe*  
*rotating gear box*

*WAI 106266*

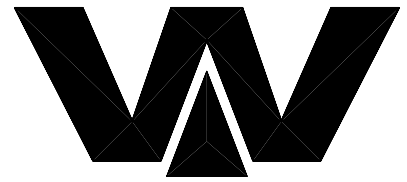

*Waitzinger*  
*Baumaschinen GmbH*

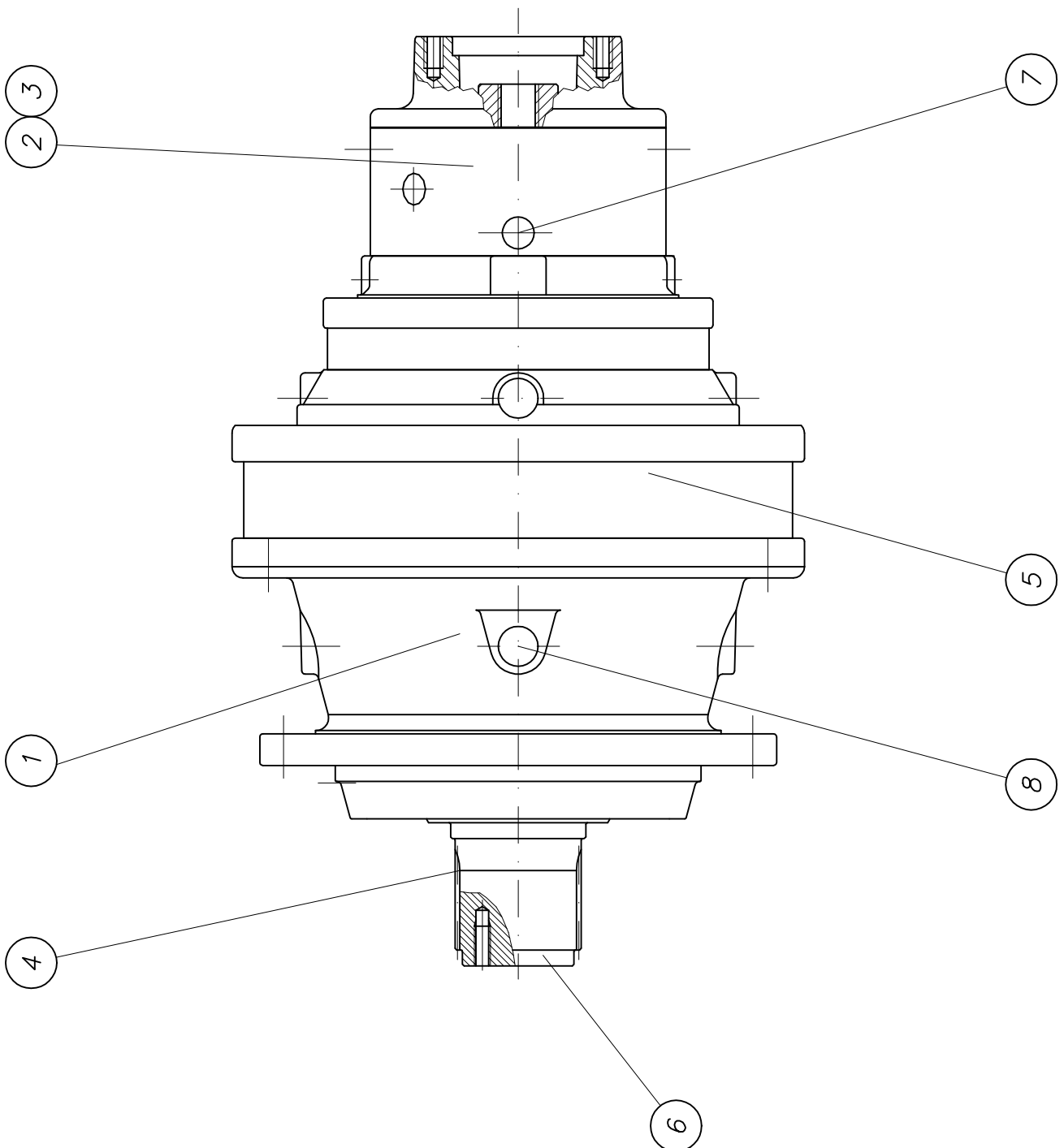



# PARTS LIST

part list	description	created	index	valid from	valid to	
WAI106266	gearbox PG1602-MFS SOM	08.03.01 Mi				
pos	description stock	ident-no dimensions	DIN material	index	weigh Kg	quantity unit
1	lamina	WAI106712				4,00 Stk
2	lamina	WAI106713				5,00 Stk
3	sealing set for rotation gearbox 36 mtr	WAI106272			0,50	1,00 Stk
4	gear 14	WAI106511			10,00	1,00 Stk
5	gearbox RE040.11201	WAI106748			140,00	1,00 Stk
6	cap RP100	WAI106749				1,00 Stk
7	gauge LL301	WAI106750			0,00	1,00 Stk
8	breather FS020	WAI106751			1,50	1,00 Stk

*Schutzeinrichtung kpl.*  
*protection unit cpl.*

*B 62 8 012c*

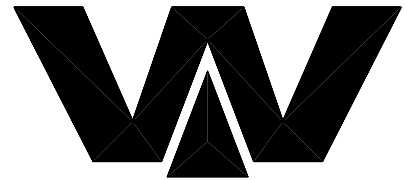

Waitzinger  
Baumaschinen GmbH

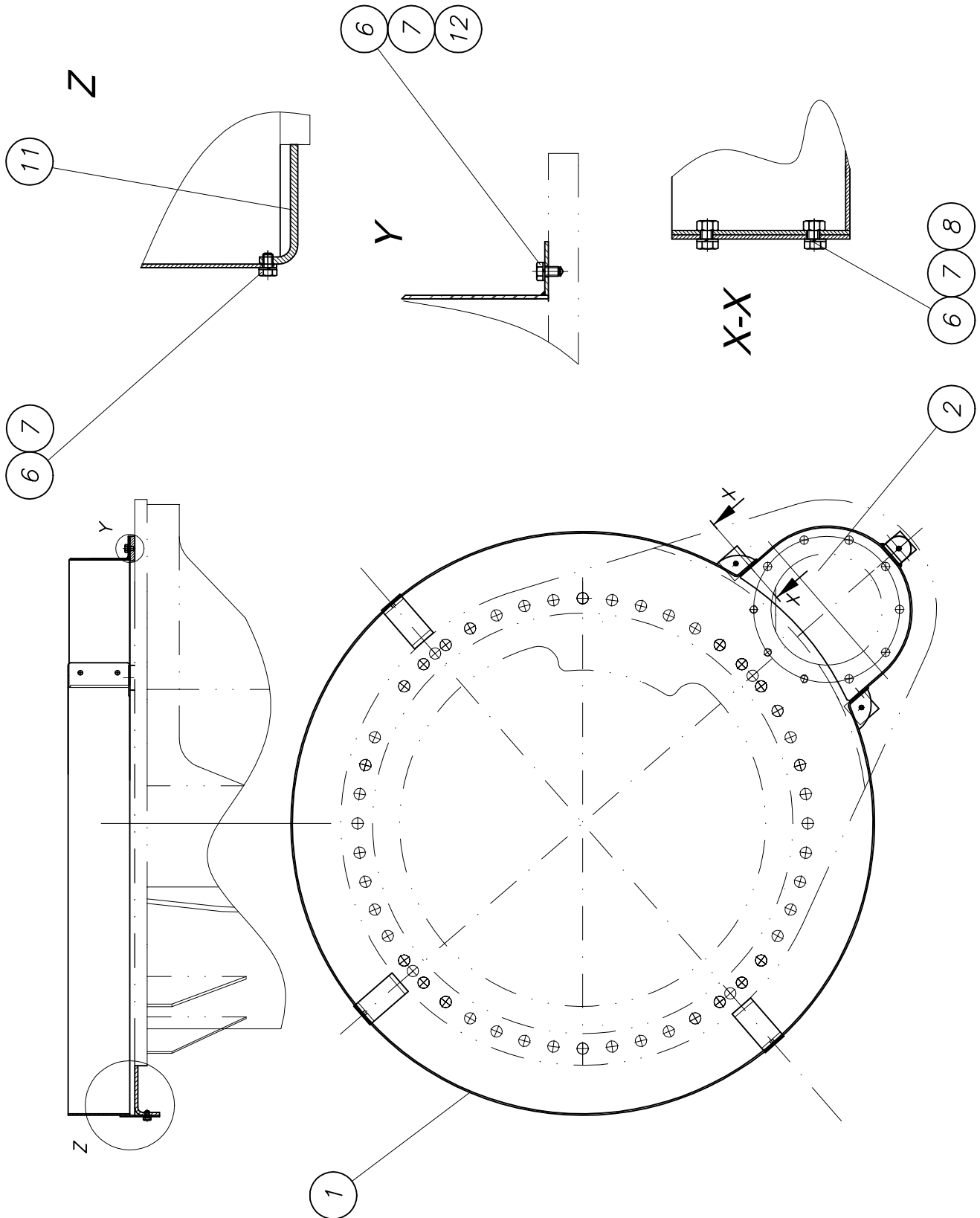



## PARTS LIST

part list	description	created	index	valid from	valid to	
B628012	turning unit protection partsKPL.36XT/ST	27.06.00 hbk	c	24.02.04		
pos	description stock	ident-no dimensions	DIN material	index	weigh Kg	quantity unit
1	rotation bearing protection own parts list	B620050			13,00	1,00 Stk
2	pinion cover f. 36 mtr. KPL. own parts list	B620055				1,00 Stk
6	hexagon bolt M 8 x 12 DIN 933 8.8	WAI103274				9,00 Stk
7	spring washer A8 DIN 127 VERZ.	WAI102205			0,00	11,00 Stk
8	hex. nut M8 DIN 934 8. VERZ.	WAI102880				4,00 Stk
11	holder BL 6X 50X 119	B620058 Bl 6x50x119	1543/EN10029 St37-2	b 27.01.03	0,30	4,00 Stk
12	hexagon bolt M 8 x 50 DIN 931 8.8	WAI108743				2,00 Stk

*Abstützung kpl.  
outrigger cpl.*

*B 63 8 010*

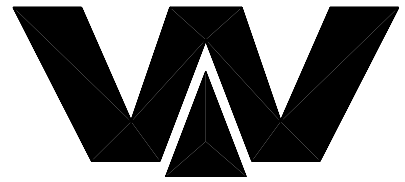

Waitzinger  
Baumaschinen GmbH

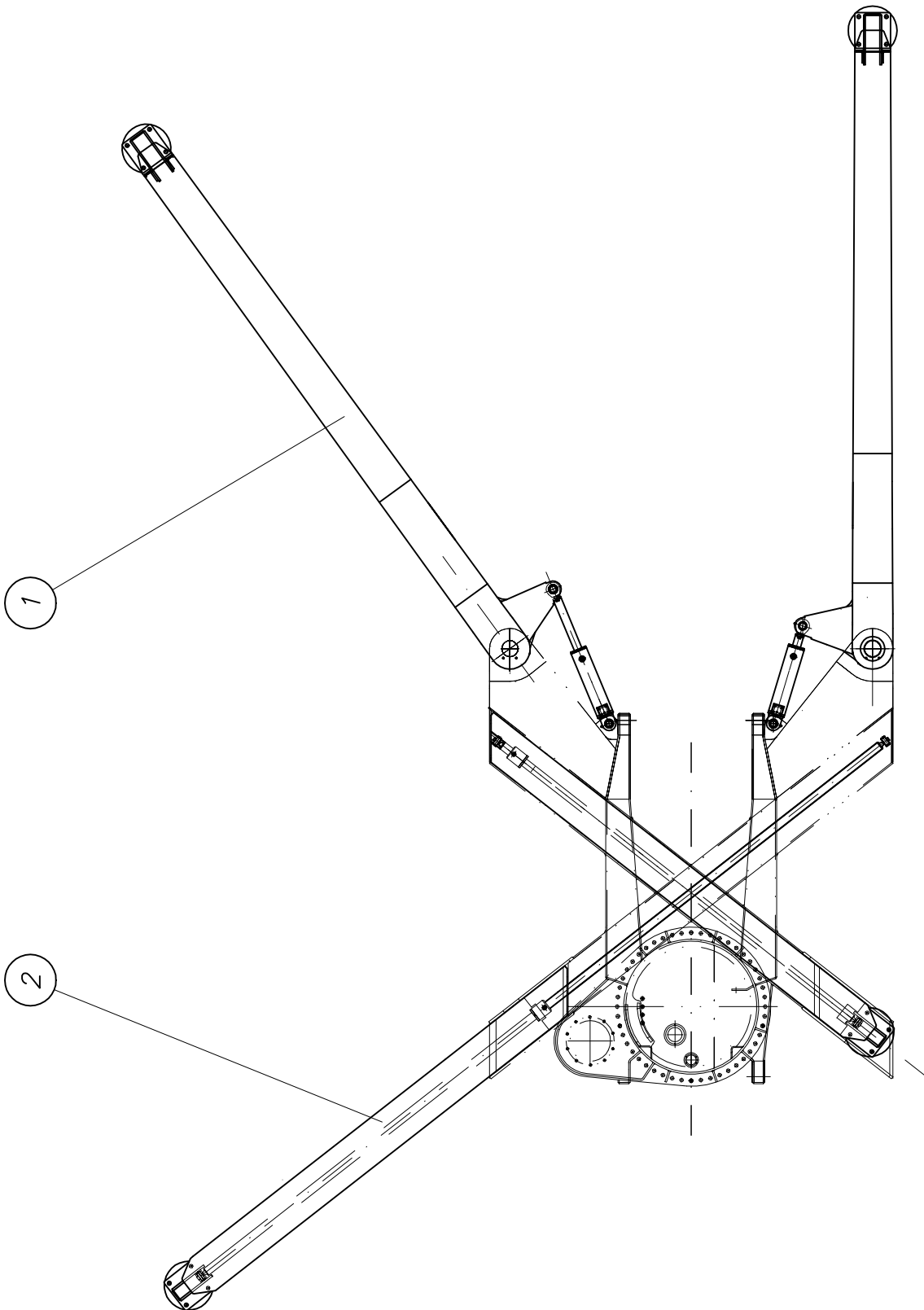



## PARTS LIST

<b>part list</b>	<b>description</b>	<b>created</b>	<b>index</b>	<b>valid from</b>	<b>valid to</b>	
B638010	outrigger 36 X cpl	05.07.00 hbk				
<b>pos</b>	<b>description stock</b>	<b>ident-no dimensions</b>	<b>DIN material</b>	<b>index</b>	<b>weigh Kg</b>	<b>quantity unit</b>
1	outrigger rear 36 X cpl own parts list	B638011				1,00 Stk
2	outrigger front 36 X cpl own parts list	B638012				1,00 Stk



Abstützung hinten kpl.  
outrigger rear cpl.

B 63 8 011

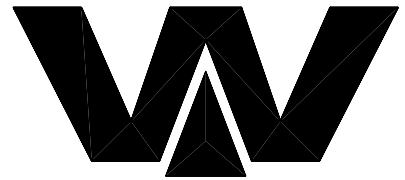

Waitzinger  
Baumaschinen GmbH

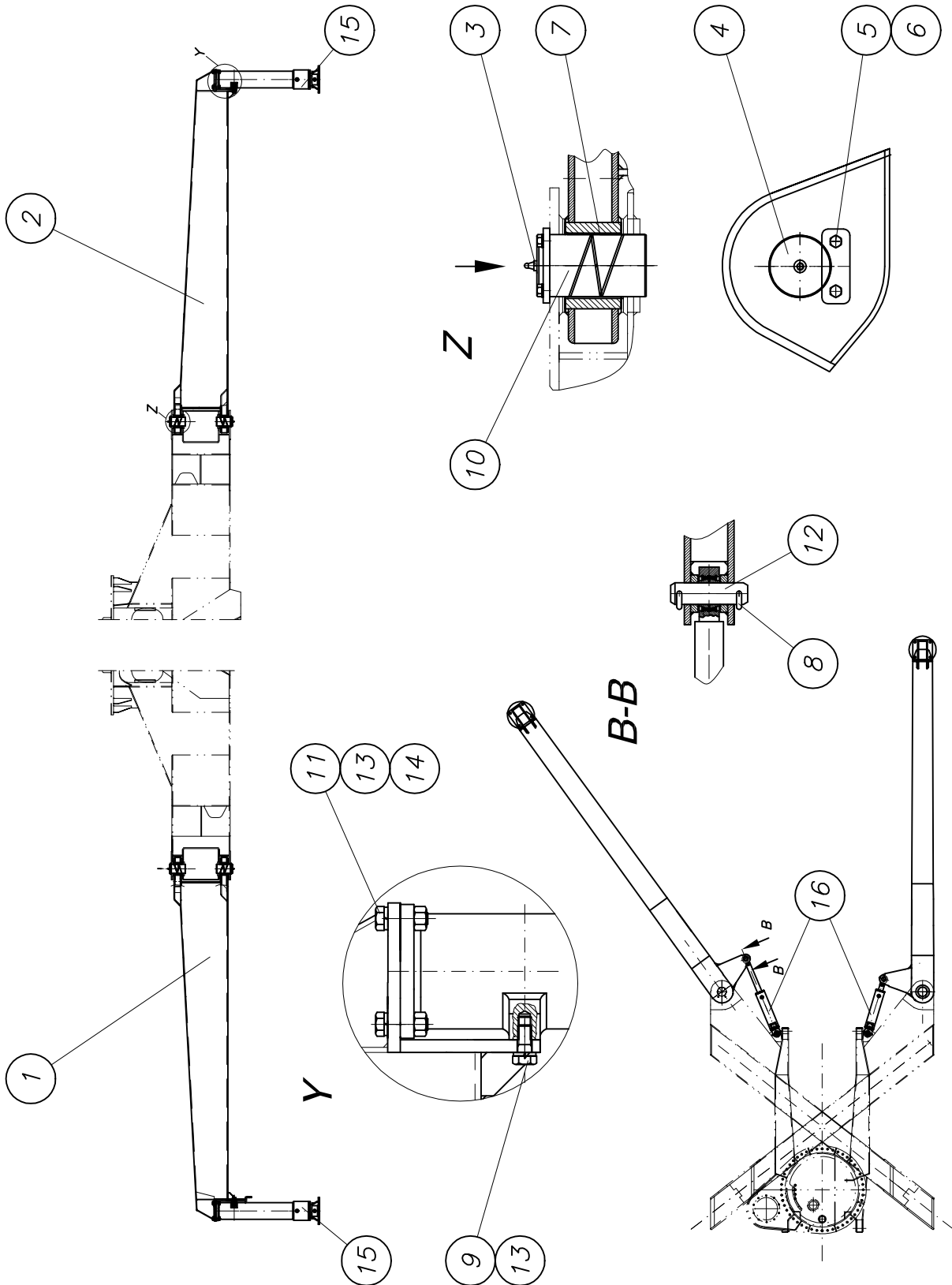



## PARTS LIST

part list	description	created	index	valid from	valid to	
B638011	outrigger rear 36 X cpl	26.06.00 hbk				
pos	description stock	ident-no dimensions	DIN material	index	weigh Kg	quantity unit
1	rear left stabilizer 36X own parts list	B638105			400,00	1,00 Stk
2	rear right stabilizer 36X own parts list	B638115			400,00	1,00 Stk
3	grease nipple H1 M10 X 1 DIN 71412	WAI100805			0,01	4,00 Stk
4	Embed plate 45 x 120	B610030 FI 45 x 120 x 1	1017 S235JR		0,04	4,00 Stk
5	spring washer A12 DIN 127 VERZ.	WAI102896				8,00 Stk
6	hex. bolt M12x30 DIN 933 8.8	WAI102107			0,04	8,00 Stk
7	bushing CD100.105090	WAI106220				4,00 Stk
8	split pin 8 x 63 VERZ. DIN 94	WAI102875				4,00 Stk
9	hexagon bolt M 22 x 50 DIN 933 10.9	WAI105967				4,00 Stk
10	pin 100 x 176	B610029 Rd 105 x 180	1013 42CrMo4V	a 09.01.03	10,50	4,00 Stk
11	nut M22 DIN 934 10.	WAI104827				8,00 Stk
12	pin 35 x 124	B610020 Rd 40 x 130	1013 C40		1,00	2,00 Stk
13	spring washer A22 DIN 127	WAI105030				12,00 Stk
14	hexagon bolt M 22 x 70 DIN 933 10.9	WAI104826				8,00 Stk
15	jack cylinder rear cpl. own parts list	B630100		a 02.06.05	155,00	2,00 Stk
16	swing cylinder cpl. own parts list	B639246		a 02.06.05	155,00	2,00 Stk

*Abstützylinder hinten kpl.*

*jack cylinder rear cpl.*

*B 63 0 100a*



Waitzinger  
Baumaschinen GmbH

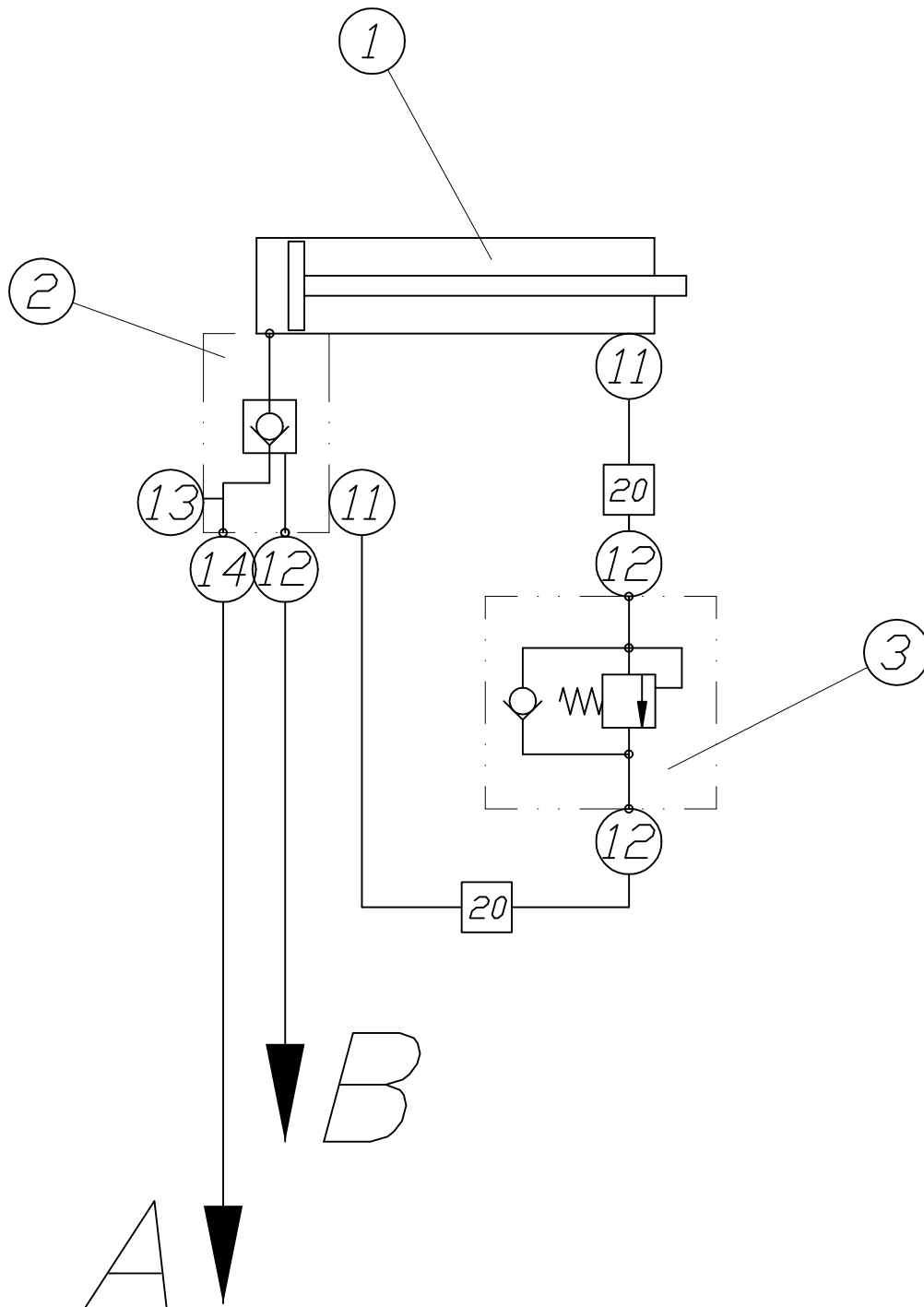



## PARTS LIST

part list	description	created	index	valid from	valid to	
B630100	jack cylinder rear cpl.	15.09.03 Mi	a	02.06.05		
pos	description stock	ident-no dimensions	DIN material	index	weigh Kg	quantity unit
1	jack cylinder 1L5 and 2L5 160/140X 785 own parts list	WAI106208		a 28.04.03	155,00	1,00 Stk
2	outrigger holding valve	WAI106360			1,10	1,00 Stk
3	valve SVC 46 F-30	WAI106335				1,00 Stk
11	banjo coupling L12 RD	WAI103684				2,00 Stk
12	straight male stud couplings L12D	WAI100548				3,00 Stk
13	locking screw G 3/8	WAI100521				1,00 Stk
14	straight male stud couplings L15-G 3/8"	WAI103704				1,00 Stk
20	hydr. pipe 12 x 2	WAI102022			0,49	0,80 Mtr

*Abstützylinder*  
*jack cylinder*

*WAI 106208a*

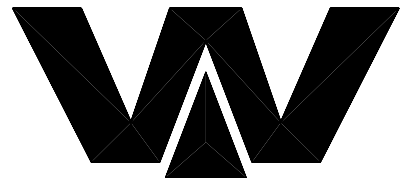

Waitzinger  
Baumaschinen GmbH

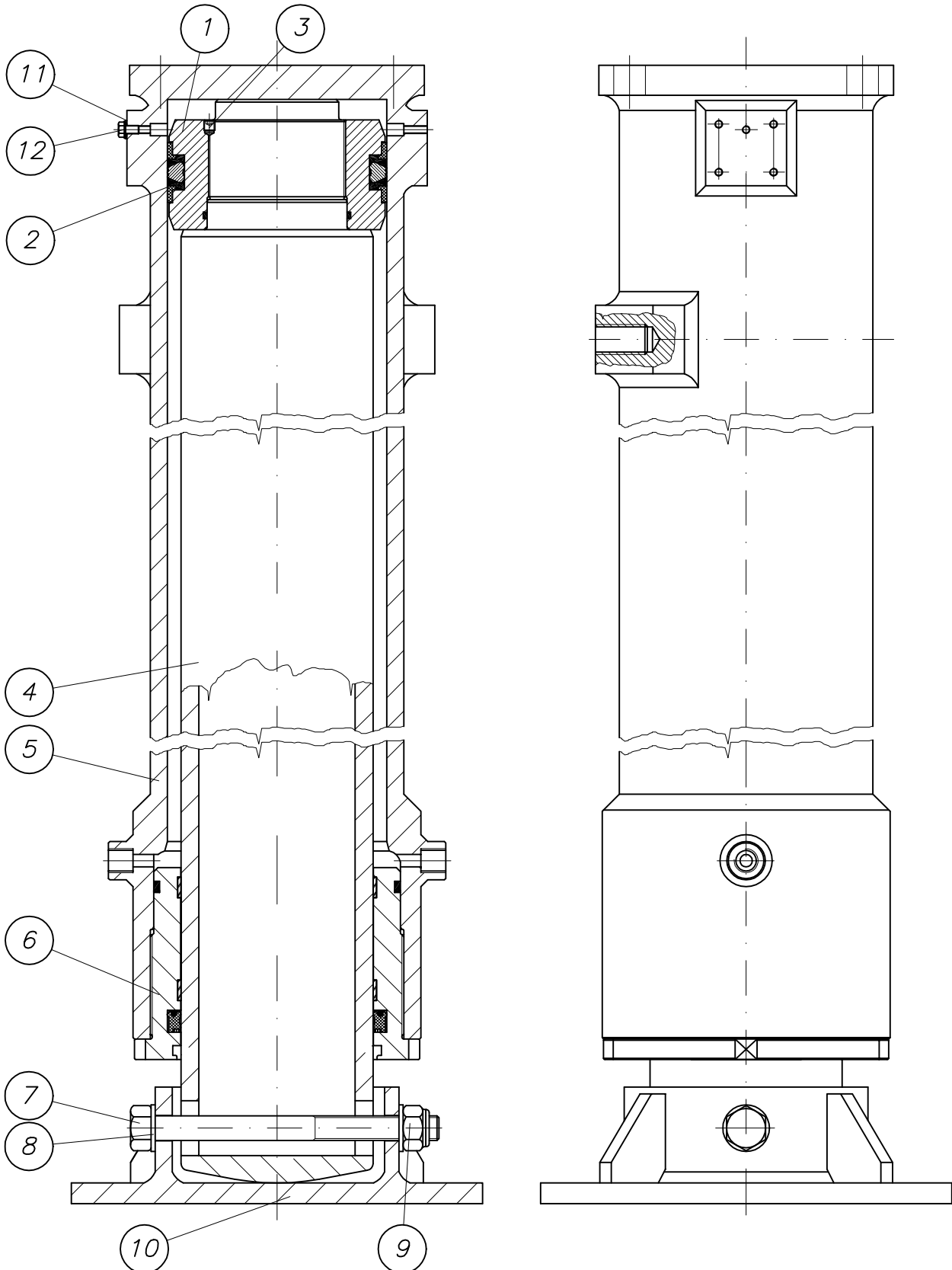



# PARTS LIST

part list	description	created	index	valid from	valid to	
WAI106208	jack cylinder 1L5 and 2L5 160/140X 785	26.03.01 Mi	a	28.04.03		
pos	description stock	ident-no dimensions	DIN material	index	weigh Kg	quantity unit
1	piston	WAI106770				1,00 Stk
2	sealing kit for front and rear	WAI104040				1,00 Stk
3	set screw	WAI106771				1,00 Stk
4	piston rod	WAI106772				1,00 Stk
5	cylinder	WAI106773				1,00 Stk
6	piston nut	WAI106774				1,00 Stk
7	hex head screw	WAI106775				1,00 Stk
8	washer	WAI106776				2,00 Stk
9	lock nut	WAI106777				1,00 Stk
10	foot	WAI106778				1,00 Stk
11	sealing ring	WAI106788				1,00 Stk
12	Cap	WAI106789				1,00 Stk

*Ausschwenkzylinder kpl.*  
*swing cylinder cpl.*

*B 63 9 246a*

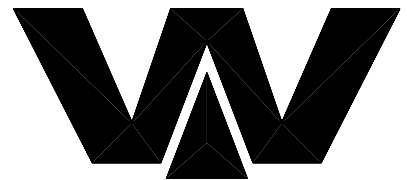

Waitzinger  
Baumaschinen GmbH

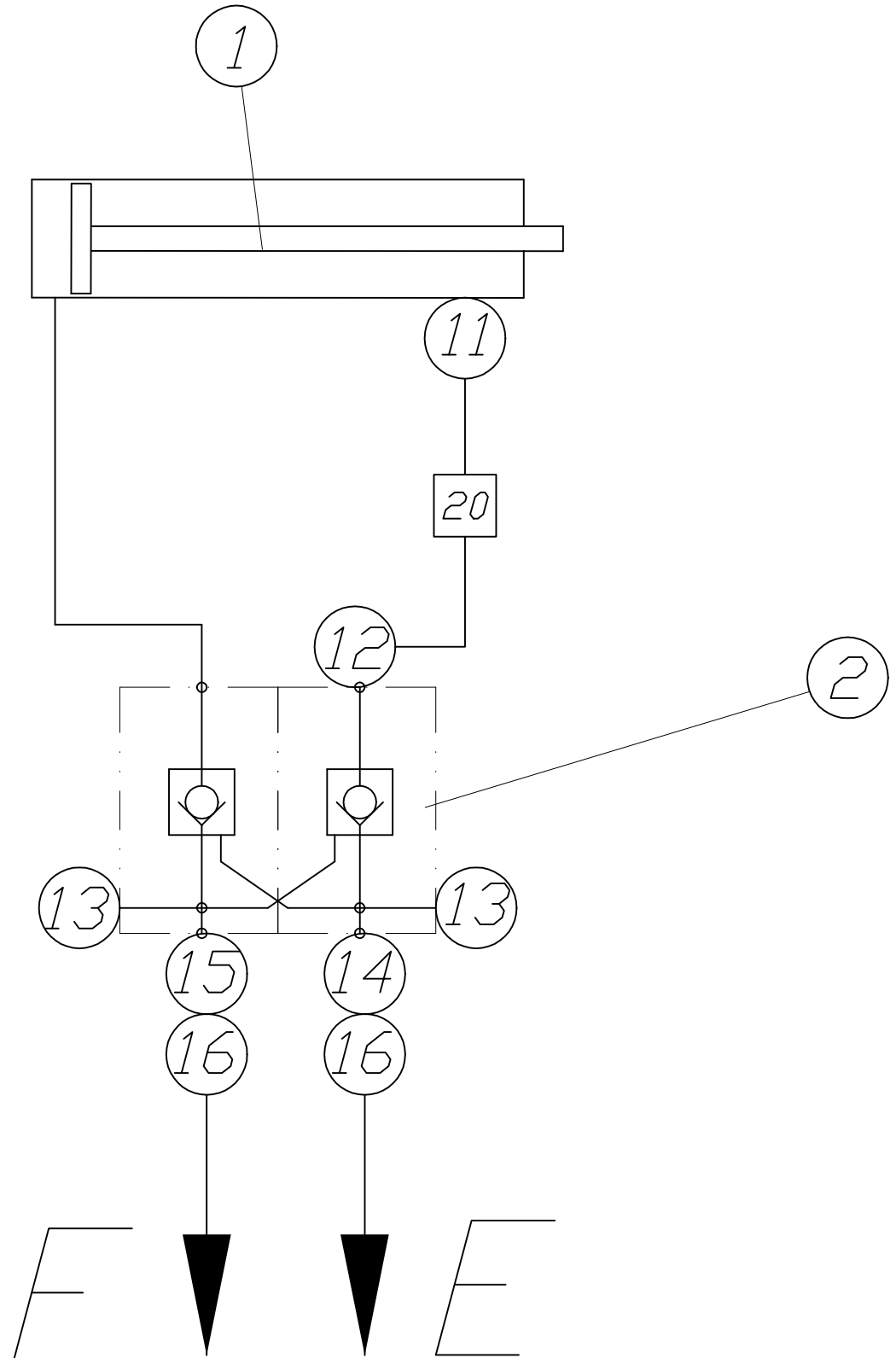



## PARTS LIST

part list	description	created	index	valid from	valid to	
B639246	swing cylinder cpl.	07.10.03 Mi	a	02.06.05		
pos	description stock	ident-no dimensions	DIN material	index	weigh Kg	quantity unit
1	swing cylinder 80/50 x 305 own parts list	WAI106210			22,50	1,00 Stk
2	pilot operated twin check valve	WAI106410				1,00 Stk
11	banjo coupling L12 RD	WAI103684				1,00 Stk
12	straight male stud couplings L12D	WAI100548				1,00 Stk
13	locking screw G 3/8	WAI100521				2,00 Stk
14	straight male stud couplings L12R 1.2 own parts list	WAI107456			0,13	1,00 Stk
15	straight male stud couplings L12R 1.5 own parts list	WAI106427			0,13	1,00 Stk
16	swivel elbow L12	WAI103794				2,00 Stk
20	hydr. pipe 12 x 2	WAI102022			0,49	0,30 Mtr



*Ausschwenkzylinder*  
*swing cylinder*

*WAI 106210*

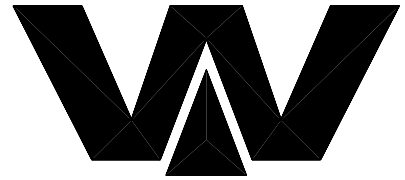

*Waitzinger*  
*Baumaschinen GmbH*

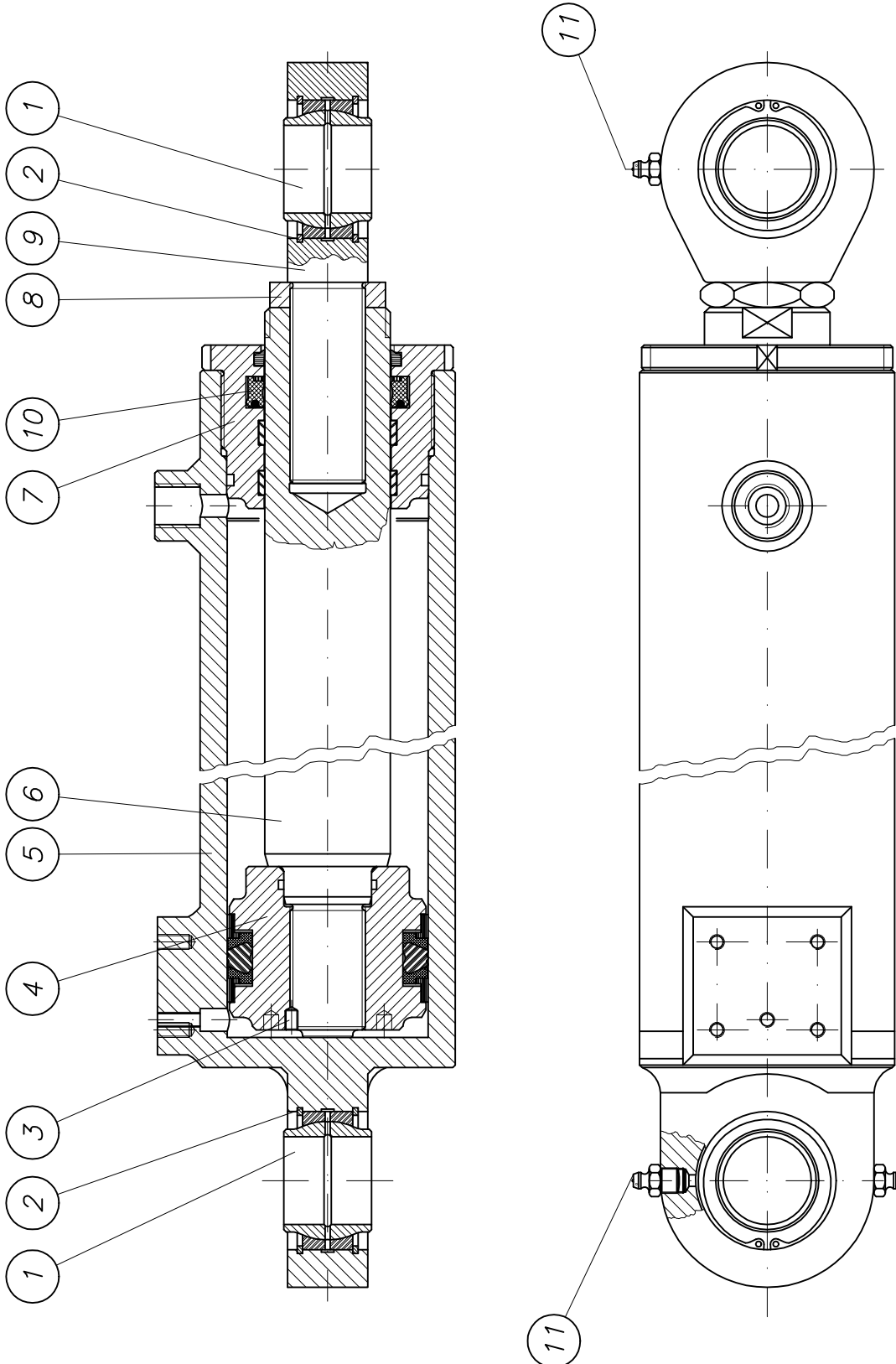



# PARTS LIST

part list	description	created	index	valid from	valid to	
WAI106210	swing cylinder 80/50 x 305	26.03.01 Mi				
pos	description stock	ident-no dimensions	DIN material	index	weigh Kg	quantity unit
1	joint bearing	WAI103626			1,50	2,00 Stk
2	clamping ring	WAI106780			0,02	4,00 Stk
3	set screw M 6 x 8	WAI103646				1,00 Stk
4	piston	WAI106781				1,00 Stk
5	housing	WAI106782				1,00 Stk
6	piston rod	WAI106783				1,00 Stk
7	head for drive cylinder	WAI106784				1,00 Stk
8	piston nut	WAI106785				1,00 Stk
9	piston head	WAI106786				1,00 Stk
10	SEALING SET FOR SWING CYLINDER 32	WAI106574				1,00 Stk
11	grease nipple H1 M10 X 1 DIN 71412	WAI100805			0,01	3,00 Stk

*Abstützung vorne kpl.*  
*outrigger front cpl.*

**B 63 8 012**

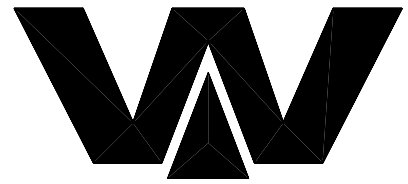

Waitzinger  
Baumaschinen GmbH

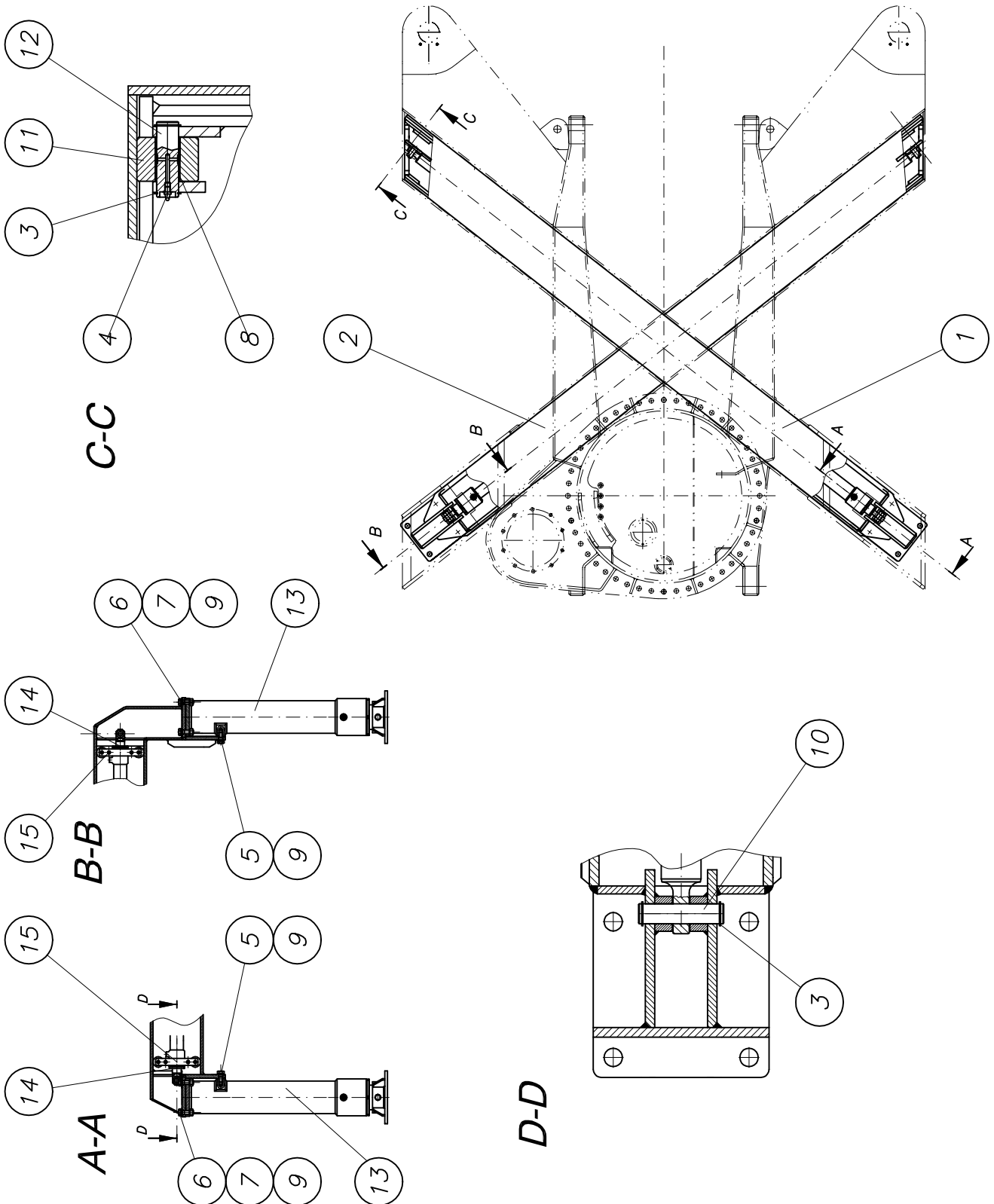



## PARTS LIST

part list	description	created	index	valid from	valid to	
B638012	outrigger front 36 X cpl	26.06.00 hbk				
pos	description stock	ident-no dimensions	DIN material	index	weight Kg	quantity unit
1	36 X left telescope own parts list	B638135			300,00	1,00 Stk
2	36 XT right telescope own parts list	B638145			300,00	1,00 Stk
3	locking ring A 25 X 1.2 DIN 471	WAI103006				8,00 Stk
4	grease nipple M6 DIN 71412	WAI103355				2,00 Stk
5	hexagon bolt M 22 x 50 DIN 933 10.9	WAI105967				4,00 Stk
6	hexagon bolt M 22 x 70 DIN 933 10.9	WAI104826				8,00 Stk
7	nut M22 DIN 934 10.	WAI104827				8,00 Stk
8	bushing DU 25 X 28 X 50	WAI106236				2,00 Stk
9	spring washer A22 DIN 127	WAI105030				12,00 Stk
10	pin 25 x 106.6	B610028 Rd 25 x 100	669 St50-2K		0,40	2,00 Stk
11	roller 70 x 050, 4H102	B610027 Rd 70 x 55	669 St50-2K		0,80	2,00 Stk
12	pin 25 x 085 4P201	B610026 Rd 25 x 90	669 St50-2K		0,32	2,00 Stk
13	jack cylinder rear cpl. own parts list	B630105		a 02.06.05	155,00	2,00 Stk
14	telescopic cylinder cpl. own parts list	B630106			155,00	2,00 Stk
15	guiding system telecopic cylinder own parts list	B610048		a 08.12.03	0,01	2,00 Stk





## PARTS LIST

part list	description	created	index	valid from	valid to	
B630105	jack cylinder rear cpl.	28.04.04 Mi	a	02.06.05		
pos	description stock	ident-no dimensions	DIN material	index	weigh Kg	quantity unit
1	jack cylinder 1L5 and 2L5 160/140X 785 own parts list	WAI106208		a 28.04.03	155,00	1,00 Stk
2	outrigger holding valve	WAI106360			1,10	1,00 Stk
3	valve SVC 46 F-30	WAI106335				1,00 Stk
11	banjo coupling L12 RD	WAI103684				2,00 Stk
12	straight male stud couplings L12D	WAI100548				4,00 Stk
13	locking screw G 3/8	WAI100521				1,00 Stk
16	swivel elbow L12	WAI103794				4,00 Stk
20	hydr. pipe 12 x 2	WAI102022			0,49	0,80 Mtr

*Abstützylinder*  
*jack cylinder*

*WAI 106208a*

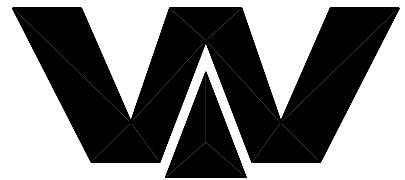

*Waitzinger*  
*Baumaschinen GmbH*

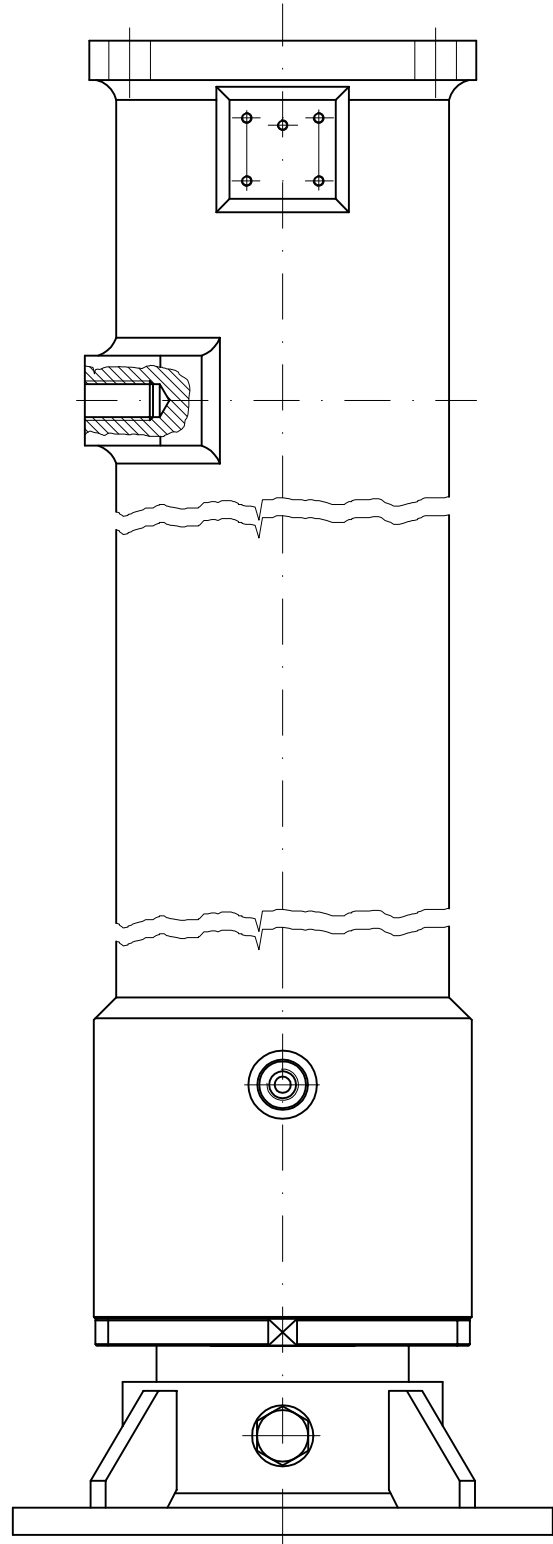
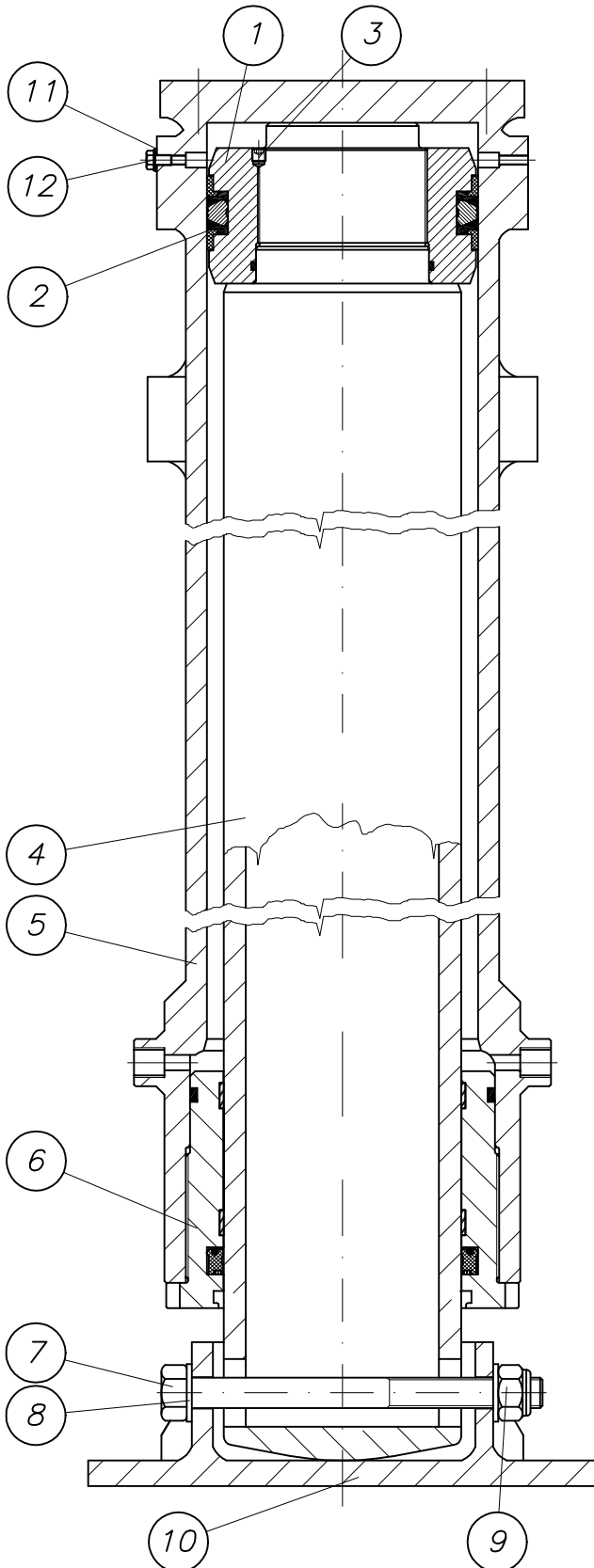



# PARTS LIST

part list	description	created	index	valid from	valid to	
WAI106208	jack cylinder 1L5 and 2L5 160/140X 785	26.03.01 Mi	a	28.04.03		
pos	description stock	ident-no dimensions	DIN material	index	weigh Kg	quantity unit
1	piston	WAI106770				1,00 Stk
2	sealing kit for front and rear	WAI104040				1,00 Stk
3	set screw	WAI106771				1,00 Stk
4	piston rod	WAI106772				1,00 Stk
5	cylinder	WAI106773				1,00 Stk
6	piston nut	WAI106774				1,00 Stk
7	hex head screw	WAI106775				1,00 Stk
8	washer	WAI106776				2,00 Stk
9	lock nut	WAI106777				1,00 Stk
10	foot	WAI106778				1,00 Stk
11	sealing ring	WAI106788				1,00 Stk
12	Cap	WAI106789				1,00 Stk



*Teleskopzylinder kpl.*  
*telescopic cylinder cpl.*

*B 63 0 106*

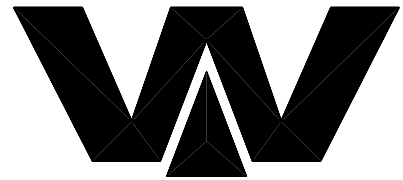

*Waitzinger*  
*Baumaschinen GmbH*

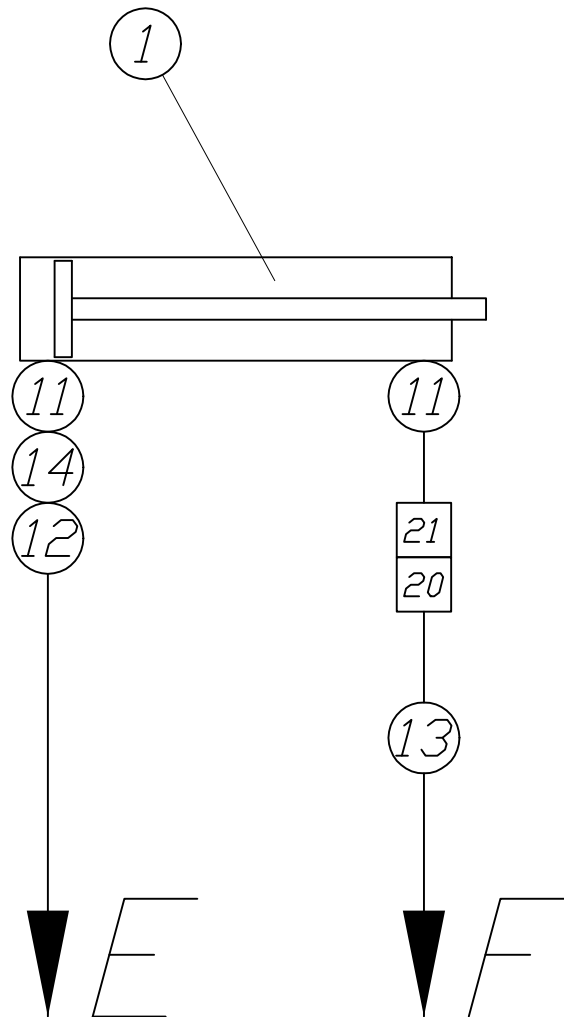



# PARTS LIST

part list	description	created	index	valid from	valid to	
B630106	telescopic cylinder cpl.	28.04.04 Mi				
pos	description stock	ident-no dimensions	DIN material	index	weigh Kg	quantity unit
1	telescopic cylinder own parts list	WAI106209				1,00 Stk
11	banjo coupling L12 RD	WAI103684				2,00 Stk
12	swivel elbow L12	WAI103794				1,00 Stk
13	straight couplings L12	WAI100603				1,00 Stk
14	straight coupling SNV 12L	WAI101949				1,00 Stk
20	hydr. pipe 12 x 2	WAI102022			0,49	2,50 Mtr
21	pipe clip 12 mm, own parts list	WAI105146			0,07	1,00 Stk

*Teleskopzylinder kpl.*  
*telescopic cylinder cpl.*

**WAI 106209**

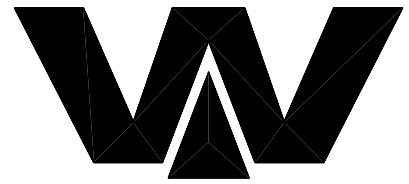

Waltzing  
Baumaschinen GmbH

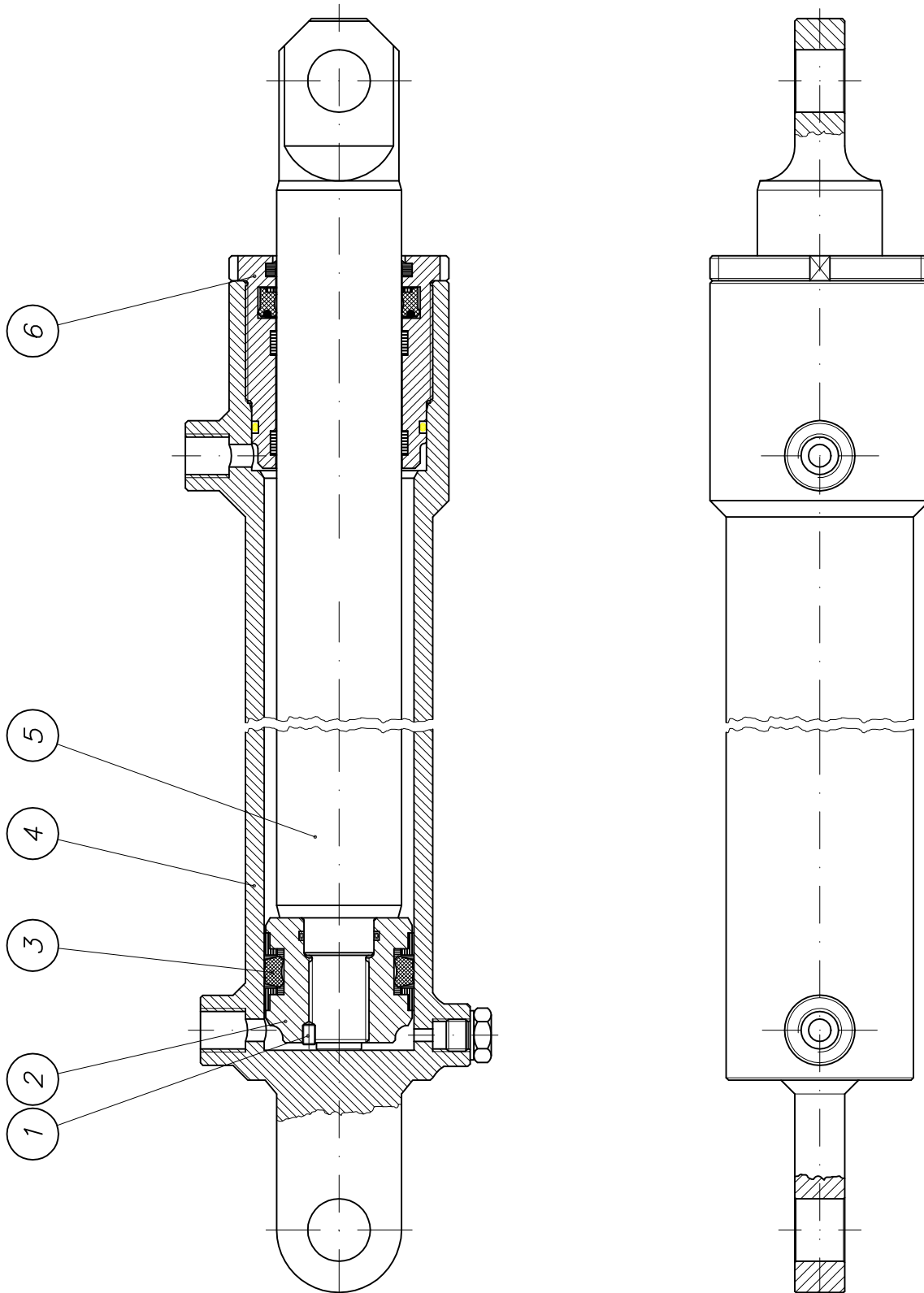



# PARTS LIST

part list	description	created	index	valid from	valid to	
WAI106209	telescopic cylinder	26.04.04 Mi				
pos	description stock	ident-no dimensions	DIN material	index	weigh Kg	quantity unit
1	set screw M 6 x 8	WAI103646				1,00 Stk
2	piston	WAI106790				1,00 Stk
3	sealing set for telescopic cylinder	WAI108880				1,00 Stk
4	housing	WAI108881				1,00 Stk
5	piston rod	WAI108882				1,00 Stk
6	head for drive cylinder	WAI108883				1,00 Stk

*Führung Teleskopzylinder kpl.*  
*guiding for telescope cylinder cpl.*

**B 61 0 048a**

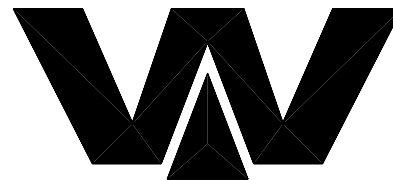

Waitzinger  
Baumaschinen GmbH

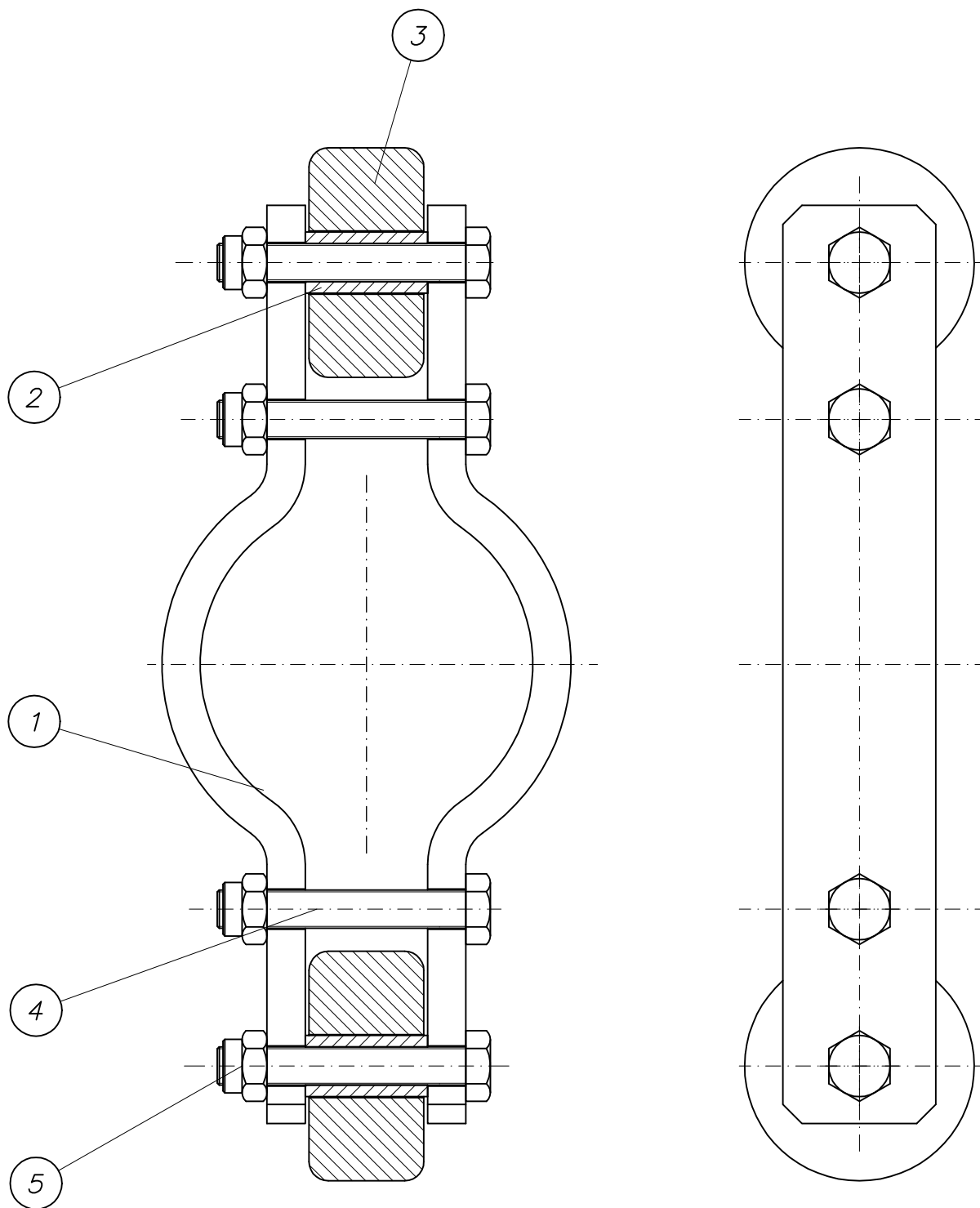



## PARTS LIST

part list	description	created	index	valid from	valid to	
B610048	guiding system telescopic cylinder	11.09.00 hbk	a	08.12.03		
pos	description stock	ident-no dimensions	DIN material	index	weigh Kg	quantity unit
1	plate	B610045 FI40x258.5x10	1017 S355J2G3	a 08.12.03	0,79	2,00 Stk
2	pipe	B610046 Rohr D15x2.5x32	2391 St52		0,02	2,00 Stk
3	wheel	B610047 Rd 60 x 30	Polyamid		0,02	2,00 Stk
4	hexagon bolt M 10 x 65	WAI105298				4,00 Stk
5	hex. nut M10 DIN985 8.	WAI102125			0,01	4,00 Stk





## PARTS LIST

part list	description	created	index	valid from	valid to	
B718001	hydr. system boom 36m XT cpl.	30.04.04 ute				
pos	description stock	ident-no dimensions	DIN material	index	weigh Kg	quantity unit
2	pipng diagram control block boom own parts list	B718002		b 27.07.04		1,00 Stk
3	locking valve LHDV33H-25W-B6-150/150-	WAI106290				1,00 Stk
10	standpipe reducers L12-8	WAI101727				1,00 Stk
11	straight male stud couplings L8	WAI103740				3,00 Stk
12	straight male stud couplings L12 RD 1/2"	WAI105400				7,00 Stk
13	swivel elbow L12	WAI103794				2,00 Stk
14	adjustable elbow bodies L8	WAI103793				2,00 Stk
15	swivel barrel tee L8	WAI103787				1,00 Stk
16	swivel barrel tee L12	WAI103788				1,00 Stk
17	straight couplings L12	WAI103752				1,00 Stk
18	bulkhead coupling L12	WAI103778				8,00 Stk
50	hydraulic hose DN10 x 3400	WAI106869				8,00 Stk
51	hydraulic hose DN06 x 450	WAI106504				1,00 Stk
52	hydraulic hose DN10 x 700	WAI101605				2,00 Stk
53	hydraulic hose DN06 x 900	WAI106506				1,00 Stk
55	hydraulic hose DN10 x 1250	WAI106508				8,00 Stk



Maststeuerblock kpl.  
control block boom cpl.

B 71 8 002b

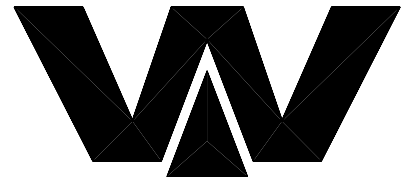

Waitzinger  
Baumaschinen GmbH

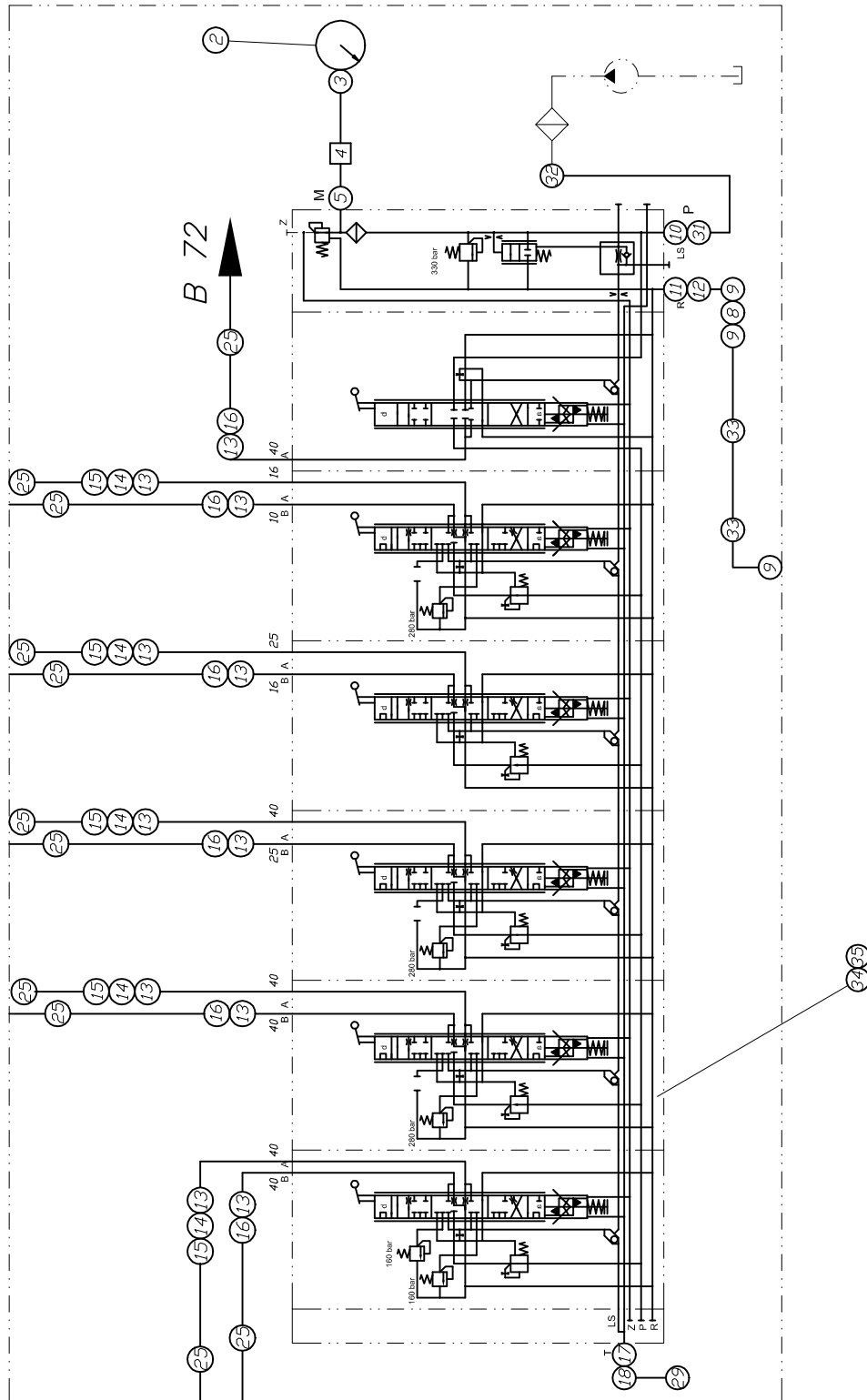



## PARTS LIST

part list	description	created	index	valid from	valid to	
B718002	piping diagram control block boom	02.12.03 hbk	b	27.07.04		
pos	description stock	ident-no dimensions	DIN material	index	weigh Kg	quantity unit
1	set of pipes for boom control block	WAI107048				1,00 Stk
2	pressure gauge 1/4" / 600 bar	WAI100132			0,27	1,00 Stk
3	pressure gauge connection 2103-05-01.00	WAI100197			0,01	1,00 Stk
4	measuring hose, S110-AC-AC-0050	WAI105132			0,13	1,00 Stk
5	screw coupling	WAI101198				1,00 Stk
6	pipe clip 12mm complete	WAI102295				2,00 Stk
7	hose	WAI102117				2,60 Mtr
8	check valve 1" 3.5bar	WAI106411				1,00 Stk
9	male stud couplings L22RD 1/2"	WAI105196				1,00 Stk
10	straight male stud couplings S16 1/2"	WAI103744				1,00 Stk
11	straight male stud couplings L22-R 1"	WAI101956				2,00 Stk
12	standpipe elbows L22V	WAI101207				1,00 Stk
13	straight male stud couplings L12 RD 1/2"	WAI105400				11,00 Stk
14	straight coupling SNV 12L	WAI101949				5,00 Stk
15	elbow couplings L12	WAI100604				5,00 Stk
16	swivel elbow L12	WAI100590				6,00 Stk
17	straight male stud couplings L8RD 1/4	WAI100547			0,04	1,00 Stk
18	adjustable elbow bodies L8	WAI100589				1,00 Stk
24	hydr. pipe 22 x 2.5	WAI102312				1,00 m
25	bulkhead coupling L12	WAI101384				11,00 Stk
26	swivel barrel tee L22	WAI100557				1,00 Stk



## PARTS LIST

part list	description	created	index	valid from	valid to	
B718002	piping diagram control block boom	02.12.03 hbk	b	27.07.04		
pos	description stock	ident-no dimensions	DIN material	index	weigh Kg	quantity unit
27	standpipe reducers L22-18	WAI105350				1,00 Stk
28	straight couplings L 22	WAI102011			0,14	2,00 Stk
29	bulkhead coupling L8	WAI101379				1,00 Stk
30	pipe clip 12mm complete	WAI102295				2,00 Stk
31	swivel elbow S16	WAI100586				1,00 Stk
32	bulkhead straight couplings S16	WAI107043				1,00 Stk
34	control block for boom 24 voltage	WAI106262			32,00	1,00 Stk
35	cover for boom control block cpl. own parts list	B718005				1,00 Stk

Hydrauliksystem Mastbock kpl.  
piping diagram boom base cpl.

B 72 8 015a

1

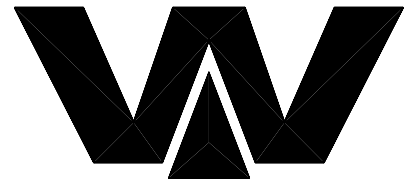

Waitzinger  
Baumaschinen GmbH

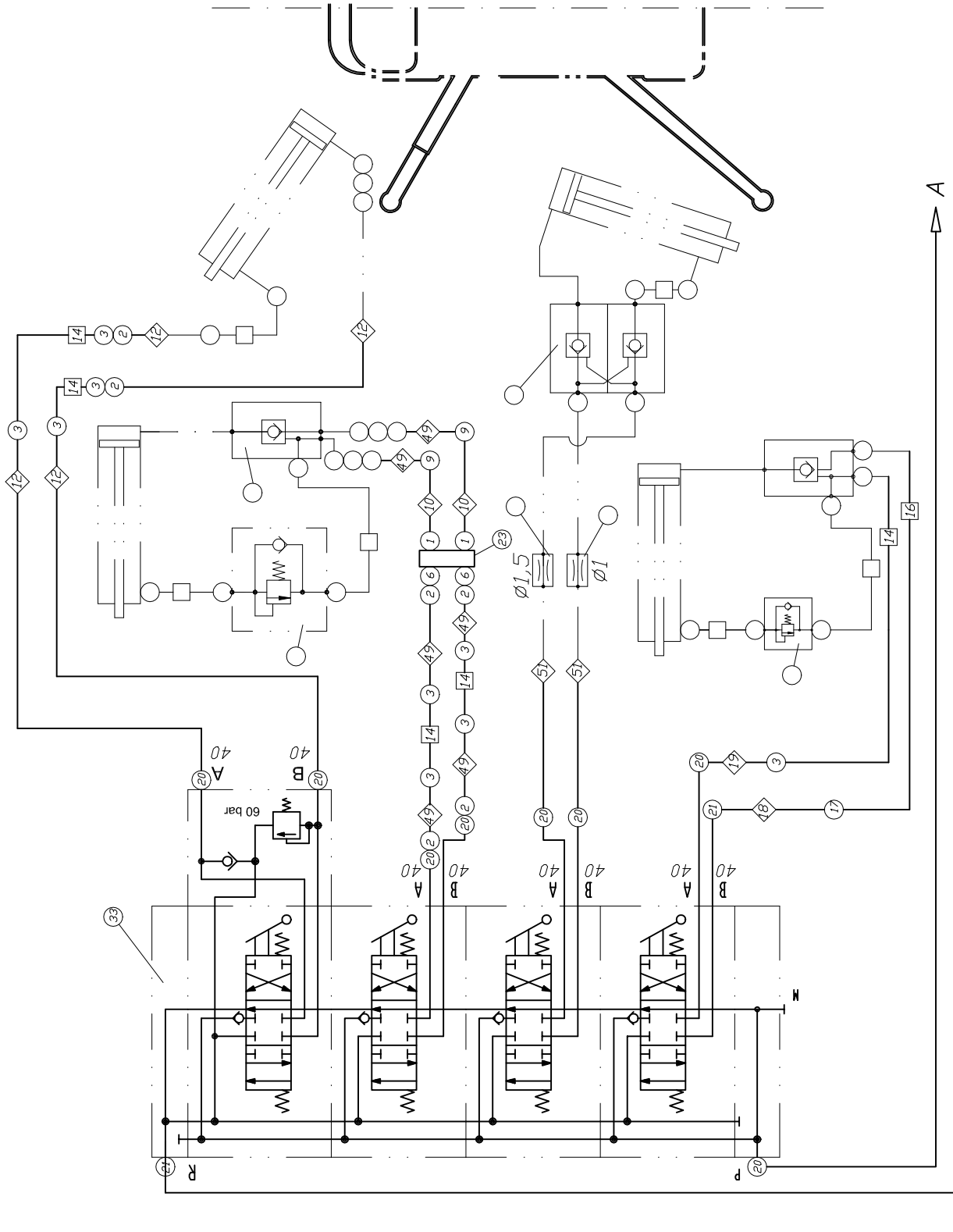

*Hydrauliksystem Mastbock kpl.  
piping diagram boom base cpl.*

**B 72 8 015a**

**2**

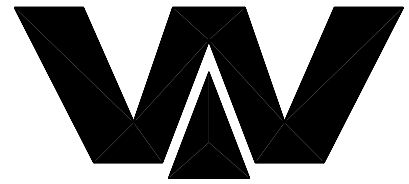

Waitzinger  
Baumaschinen GmbH

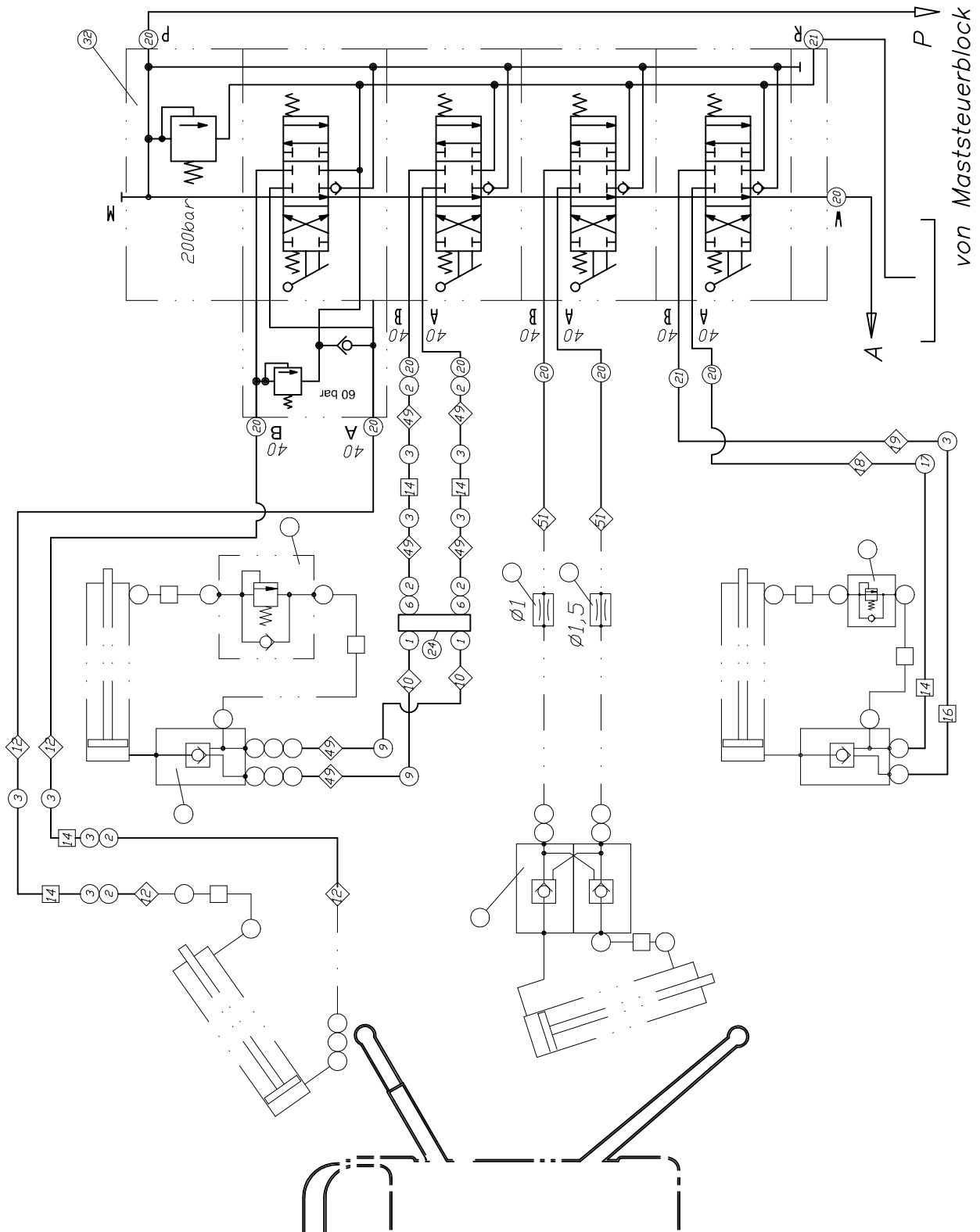

Hydrauliksystem Mastbock kpl.  
piping diagram boom base cpl.

B 72 8 015a

3

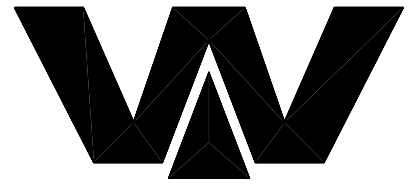

Waitzinger  
Baumaschinen GmbH

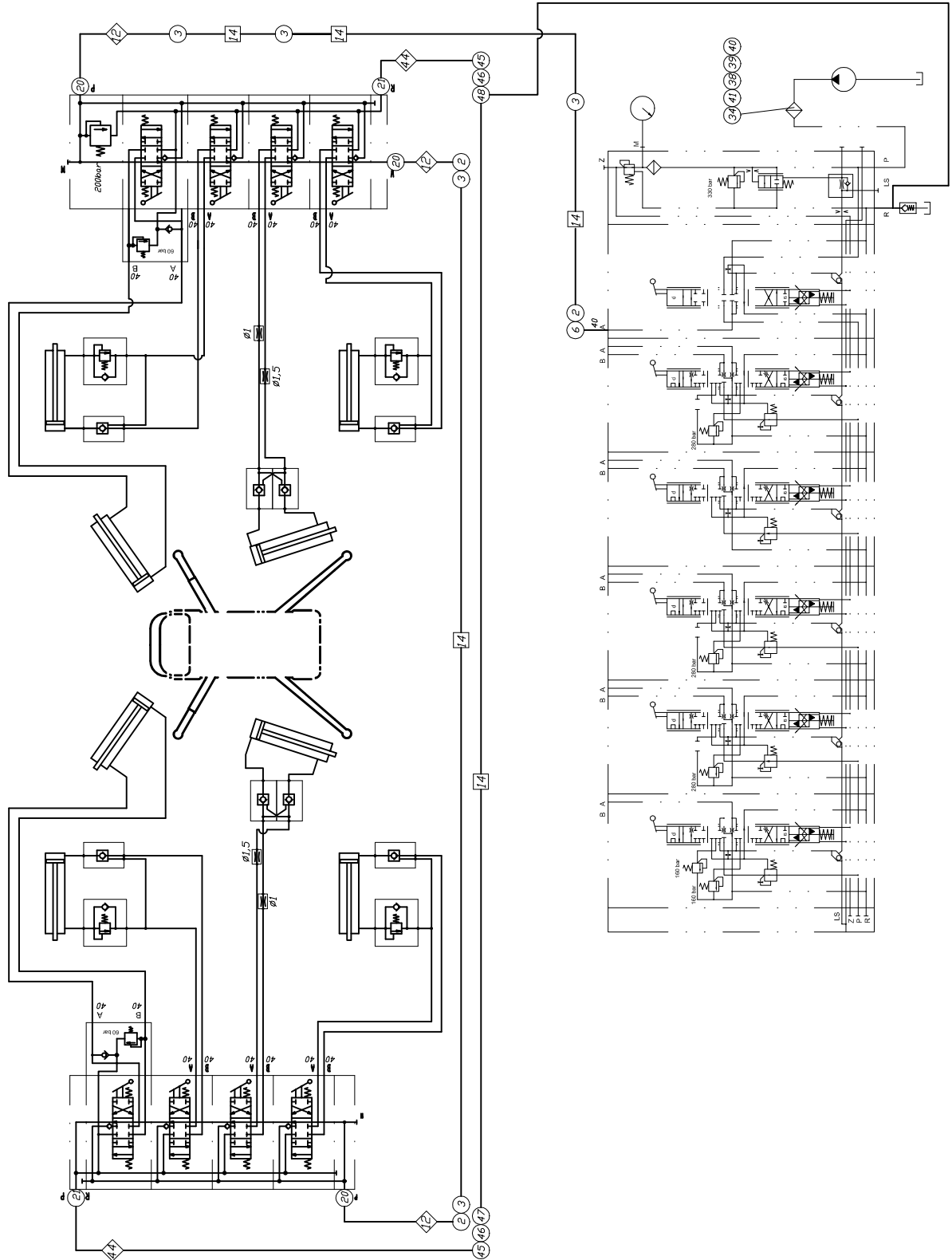



## PARTS LIST

part list	description	created	index	valid from	valid to	
B728015	piping diagram 36 XT boom base with Rabe	28.04.04 Mi	a	16.02.05		
pos	description stock	ident-no dimensions	DIN material	index	weigh Kg	quantity unit
1	banjo coupling L12 RD	WAI103684				4,00 Stk
2	swivel elbow L12	WAI100590				15,00 Stk
3	straight couplings L12	WAI100603				25,00 Stk
6	straight male stud couplings L12D	WAI100548				5,00 Stk
9	bulkhead coupling L12	WAI101384				4,00 Stk
10	hose DN10x3600	WAI106343				4,00 Stk
12	hydraulic hose DN10 x 700	WAI101605				11,00 Stk
14	hydr. pipe 12 x 2	WAI102022			0,49	10,00 Mtr
16	hydr. pipe 15 x 2.5	WAI102310				4,00 Mtr
17	straight couplings L 15	WAI100828			0,14	2,00 Stk
18	hydraulic hose DN12 x 1250	WAI107921				2,00 Stk
19	hydraulic hose DN10 x 1250	WAI106508				2,00 Stk
20	straight male stud couplings L12D	WAI100548				17,00 Stk
21	straight male stud couplings L15-G 1/2"	WAI101332				2,00 Stk
22	hydraulic pipe 18 x 2,5	WAI102942				2,00 Mtr
23	Wrapper roller (left side)	WAI106275				1,00 Stk
24	Wrapper roller (right side)	WAI106274			15,00	1,00 Stk
25	male stud couplings L18RD	WAI100345			0,13	2,00 Stk
27	welding plate for pipe clip	WAI105422			0,03	36,00 Stk
28	pipe clip 12 mm, own parts list	WAI105146			0,07	36,00 Stk
29	welding plate for pipe clip	WAI107111			0,04	6,00 Stk



## PARTS LIST

part list	description	created	index	valid from	valid to	
B728015	pipng diagram 36 XT boom base with Rabe	28.04.04 Mi	a	16.02.05		
pos	description stock	ident-no dimensions	DIN material	index	weigh Kg	quantity unit
30	pipe clip 18 mm,	WAI105148				6,00 Stk
32	valve block DCV40 right side 36XT	WAI108869			9,15	1,00 Stk
33	valve block DCV40 left side 36XT	WAI108870			9,15	1,00 Stk
34	filter 274A-2N50 own parts list	WAI106303				1,00 Stk
38	bracket	B039103 BI 8x165x191,5	1543 S235J2G3	a 04.11.04	1,35	1,00 Stk
39	cheese head screw	WAI103178			0,00	3,00 Stk
40	spring washer A10	WAI102070			0,00	3,00 Stk
41	filter element ZL 270-L-122	WAI106304			1,80	1,00 Stk
42	swivel barrel tee L18	WAI102790				1,00 Stk
44	hydraulic hose DN16 x 500	WAI108977				3,00 Stk
45	straight fitting L18	WAI100539				2,00 Stk
49	hydraulic hose DN 10 x 500	WAI104147				12,00 Stk
51	hydraulic hose DN 10 x 1000	WAI103206				4,00 Stk
52	plate	B638032 FI 60x6x80	1017 S355J2G3		0,10	2,00 Stk
53	bracket left own parts list	B638033			0,10	1,00 Stk
54	bracket right own parts list	B638034			0,10	1,00 Stk
55	angle L105 X 30 X 5 X 50	B721021			0,40	4,00 Stk
56	plate for valve	B711054 BI 8x70x75	1543/EN10029 St37-2	b 13.02.02	0,30	1,00 Stk



*Abdeckung Steuerblock kpl.*  
*cover for control block cpl.*

**B 72 1 015**

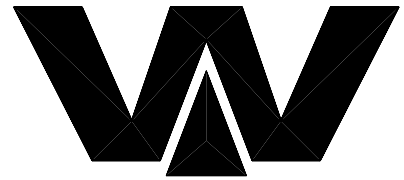

Waitzinger  
Baumaschinen GmbH

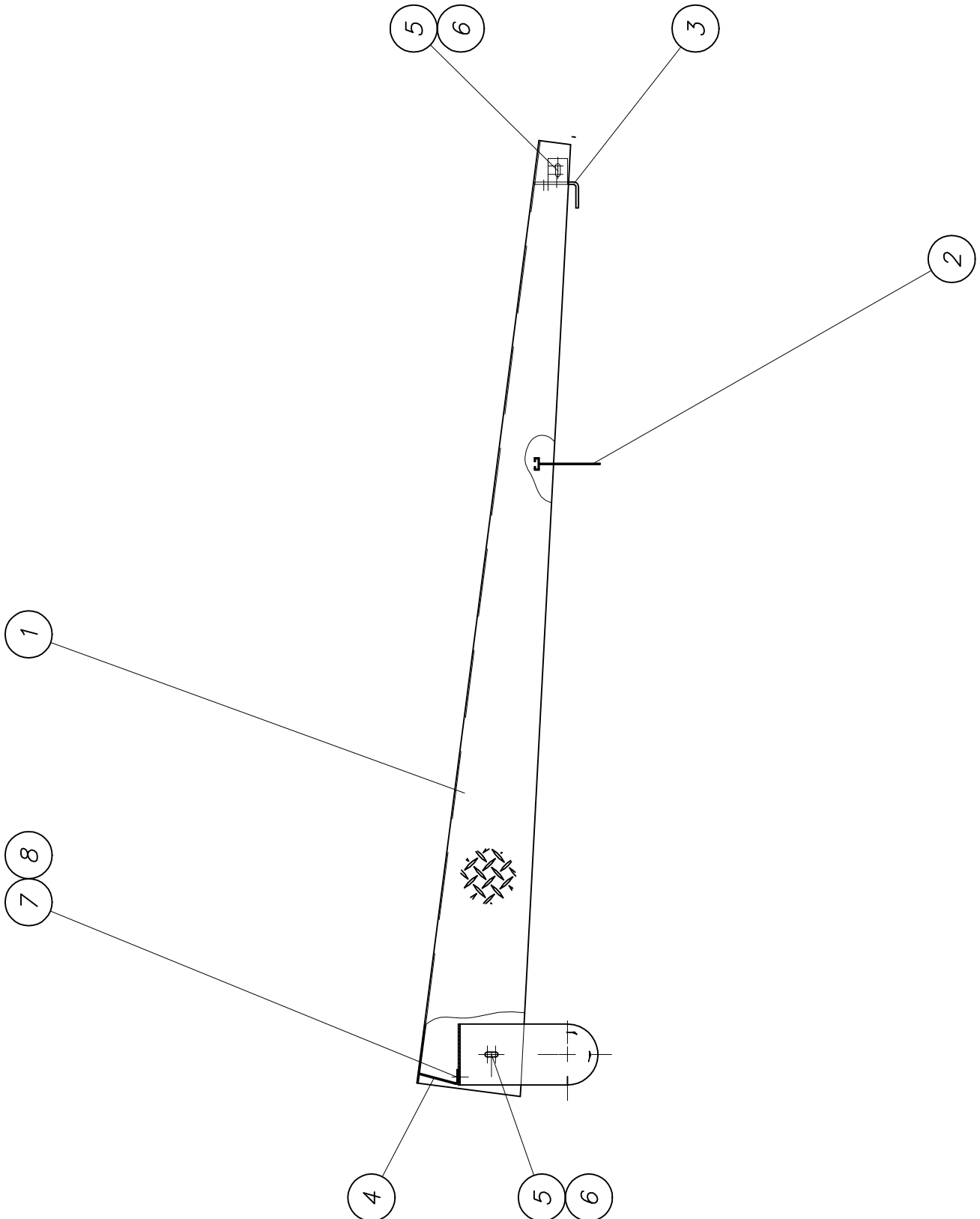



## PARTS LIST

part list	description	created	index	valid from	valid to	
B721015	cover for boom control block cpl.	05.07.01 Mi				
pos	description stock	ident-no dimensions	DIN material	index	weigh Kg	quantity unit
1	cover for boom control block	B721016 Tränenbl. 3x920	Al 99.8		13,40	1,00 Stk
2	holder own parts list	B721017			0,50	1,00 Stk
3	holder for pipes	B721019 Bl 6x100x536	1541/EN10029 S235J2G3	a 01.12.03	2,30	1,00 Stk
4	angle	B721020 Bl 3x120x440	1543/EN10029 S235J2G3	a 16.12.03	1,00	1,00 Stk
5	hexagon bolt	WAI102244				2,00 Stk
6	hex. nut M10 DIN985 8.	WAI102125			0,01	2,00 Stk
7	hexagon bolt M 8 x 16 DIN 933 8.8	WAI102873				2,00 Stk
8	stop nut M8 DIN985 8. VERZ.	WAI102111			5,00	2,00 Stk

*Transportsicherung kpl.*  
*transportation safety device*

*B 63 1 120c*

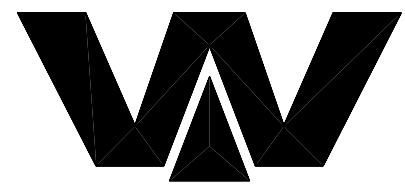

Waitzinger  
Baumaschinen GmbH

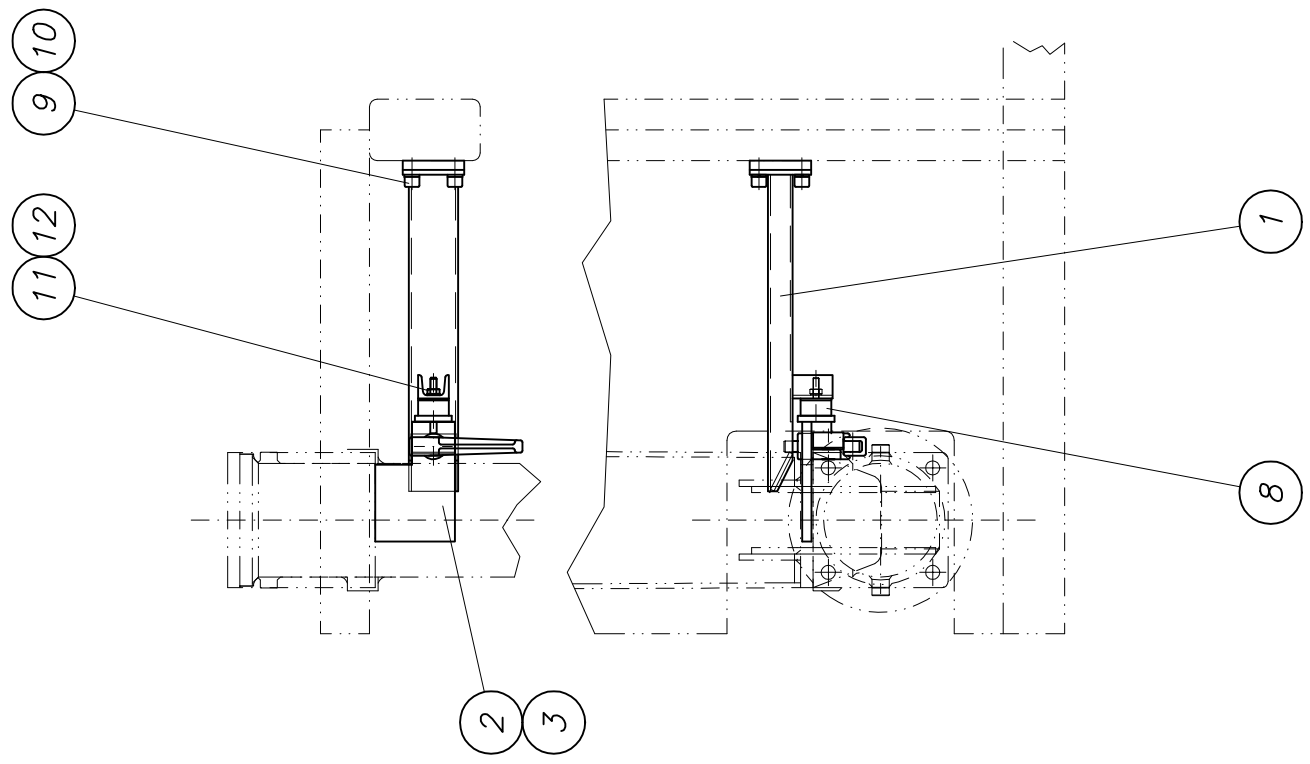
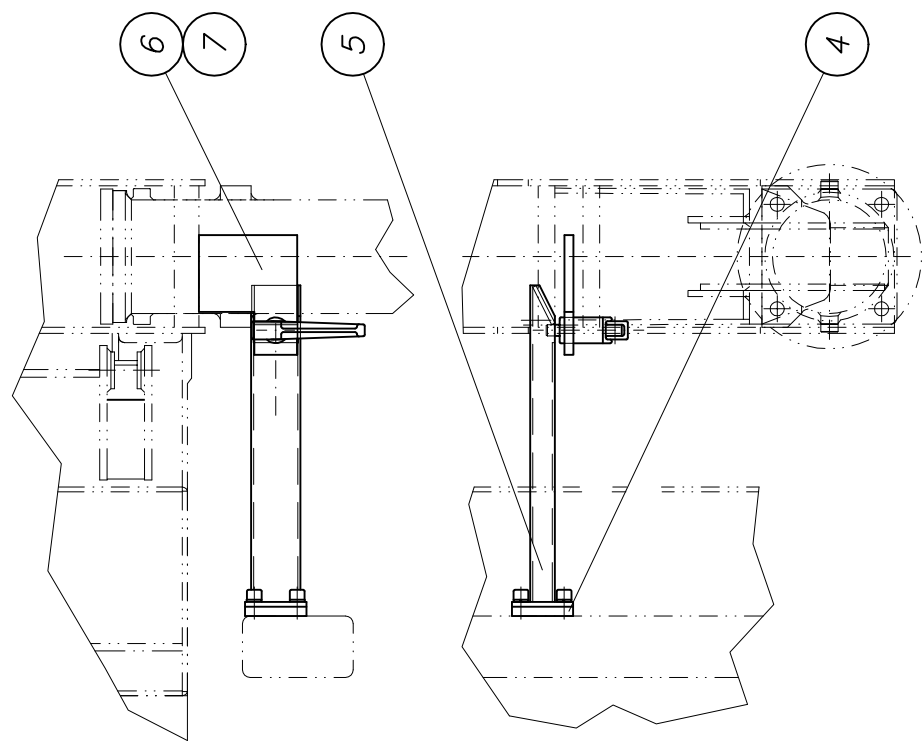



# PARTS LIST

part list	description	created	index	valid from	valid to	
B631120	transportation safety device	23.09.97 Mi	c	25.04.02		
pos	description stock	ident-no dimensions	DIN material	index	weigh Kg	quantity unit
1	support own parts list	B631121			4,50	2,00 Stk
2	mounting left own parts list	B631108				1,00 Stk
3	mounting right own parts list	B631112			3,80	1,00 Stk
4	plate	B073045 Bl 15x100x100	1543/EN10029 St37-2		0,55	4,00 Stk
5	support own parts list	B631123			4,10	2,00 Stk
6	mounting left own parts list	B631126			3,80	1,00 Stk
7	mounting right own parts list	B631124			3,80	1,00 Stk
8	rubber cushion	WAI103494			0,50	2,00 Stk
9	cheese head screw M 16 x 25	WAI103488				16,00 Stk
10	spring washer A16	WAI103489			0,01	16,00 Stk
11	spring washer A10	WAI102070			0,00	2,00 Stk
12	nut M10 DIN 934	WAI101556			0,01	2,00 Stk

# Förderleitung am Mast delivery line at boom

B 64 1 011e

1

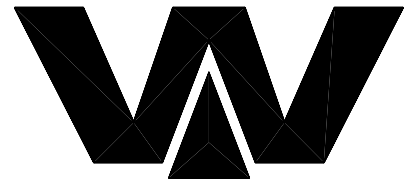

Waitzinger  
Baumaschinen GmbH

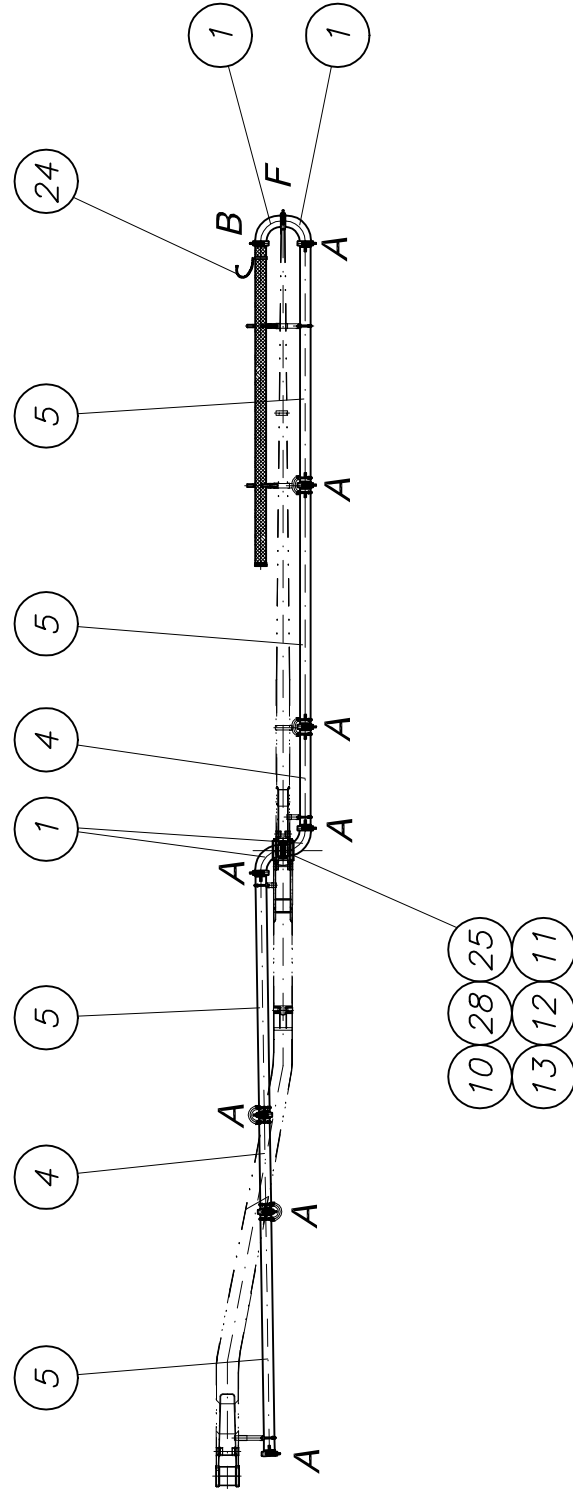
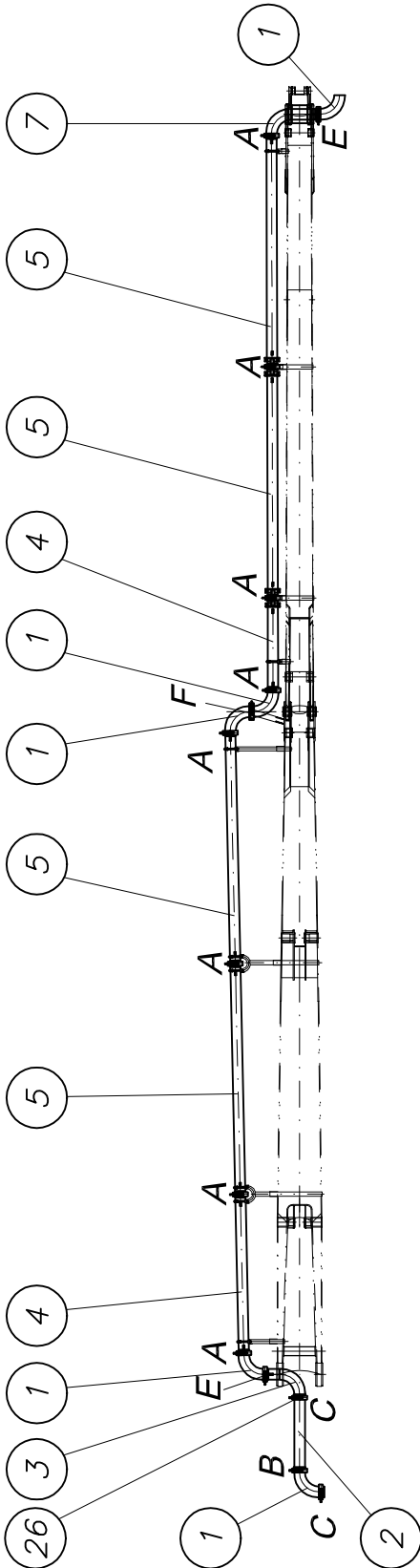

Förderleitung kpl.  
conveying pipeline cpl.

B 64 1 011e

2

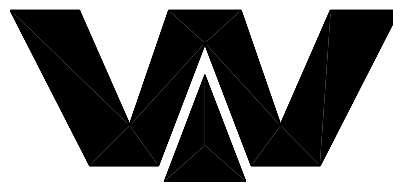

Waitzinger  
Baumaschinen GmbH

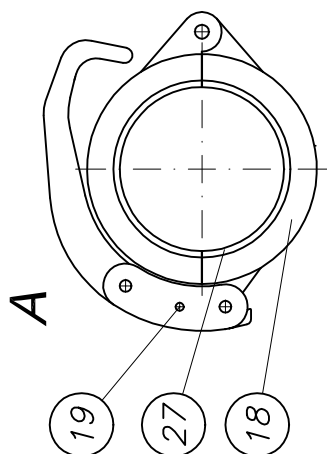
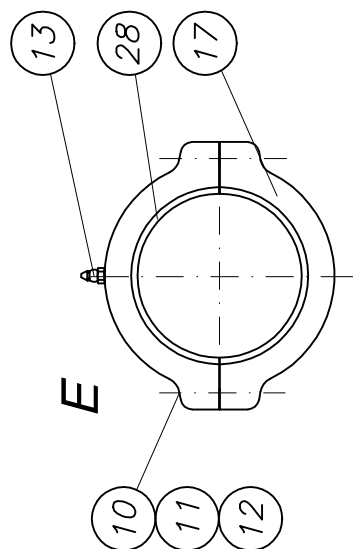
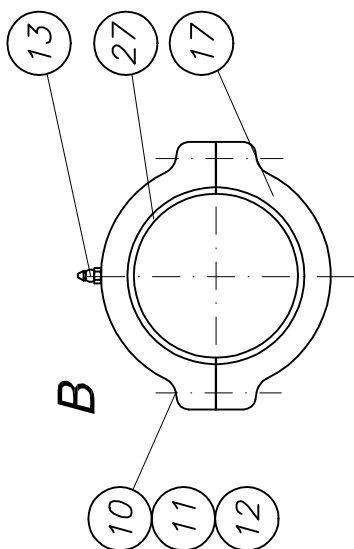
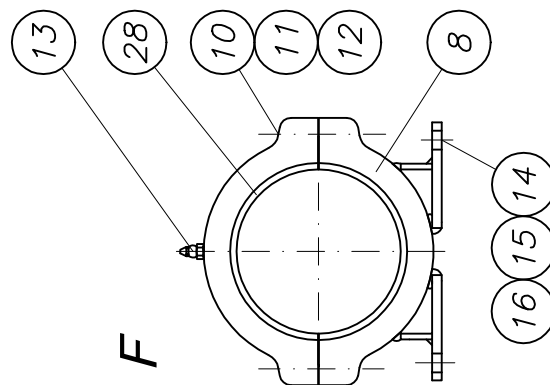
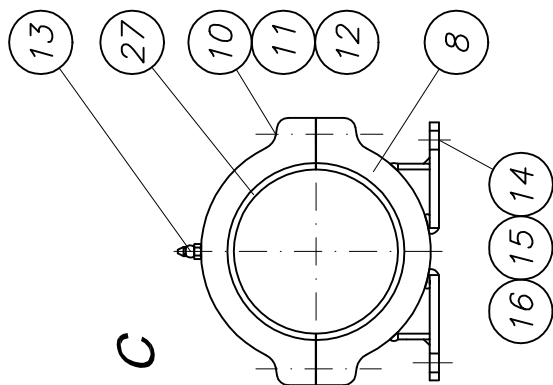



## PARTS LIST

part list	description	created	index	valid from	valid to	
B641011	delivery line cpl. St 52	22.03.01 HF	e	04.07.05		
pos	description stock	ident-no dimensions	DIN material	index	weigh Kg	quantity unit
1	concrete elbow 90 degrees	WAI100218			15,40	9,00 Stk
2	pipe DN 125 x 890	WAI106678				1,00 Stk
3	pipe DN 125 x 447	B640100		a 19.02.02		1,00 Stk
4	pipe DN 125 x 2350	WAI103718				1,00 Stk
5	pipe DN 125 x 3000	WAI100965			38,00	8,00 Stk
6	pipe DN 125 x 1500	WAI108515				2,00 Stk
7	pipe DN 125 x 608	B640101				1,00 Stk
8	2 bolts coupling 5 1/2"	WAI106676				4,00 Stk
10	socked head bolt M 12 x 55 DIN 912 8.8	WAI106462				10,00 Stk
11	spring washer A12 DIN 127 VERZ.	WAI102896				10,00 Stk
12	nut M12 DIN 934	WAI101557			0,02	10,00 Stk
13	grease nipple H1 M10 X 1 DIN 71412	WAI100805			0,01	8,00 Stk
14	cheese head screw	WAI106695				6,00 Stk
15	spring washer	WAI101976			0,00	6,00 Stk
16	stop nut M14	WAI106694			0,02	6,00 Stk
17	snap coupling 5 1/2"	WAI106677				4,00 Stk
18	snap coupling 5 1/2"	WAI101547				16,00 Stk
19	spring pin 8 mm	WAI102622				16,00 Stk
21	pipe DN 125 x 1392.5	WAI106325				1,00 Stk
24	flexible hose support kit TS24 own parts list	WAI106693				1,00 Stk
25	snap coupling 5 1/2" own parts list	B641013				1,00 Stk



## PARTS LIST

part list	description		created	index	valid from	valid to
B641011	delivery line cpl.	St 52	22.03.01 HF	e	04.07.05	
pos	description stock	ident-no dimensions	DIN material	index	weigh Kg	quantity unit
26	angle	B641066 L 60x60x5x250	1028 S355J2G3		0,90	1,00 Stk
27	three lips rubber gasket DN 5.5"	WAI107571			0,20	20,00 Stk
28	reinforced rubber gasket DN 5.5"	WAI107572			0,20	5,00 Stk



*Endschlauch  
end hose*

*WAI 101782*

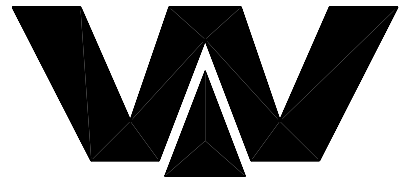

*Waitzinger  
Baumaschinen GmbH*

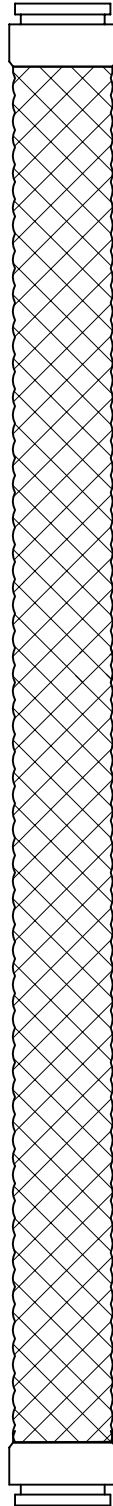

*Armpaket 36R4 kpl.*

*boom 36R4 cpl.*

*B 66 1 025*

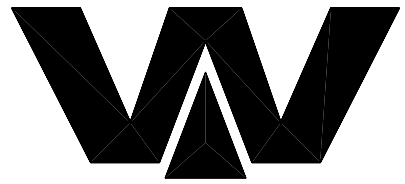

*Waitzinger  
Baumaschinen GmbH*

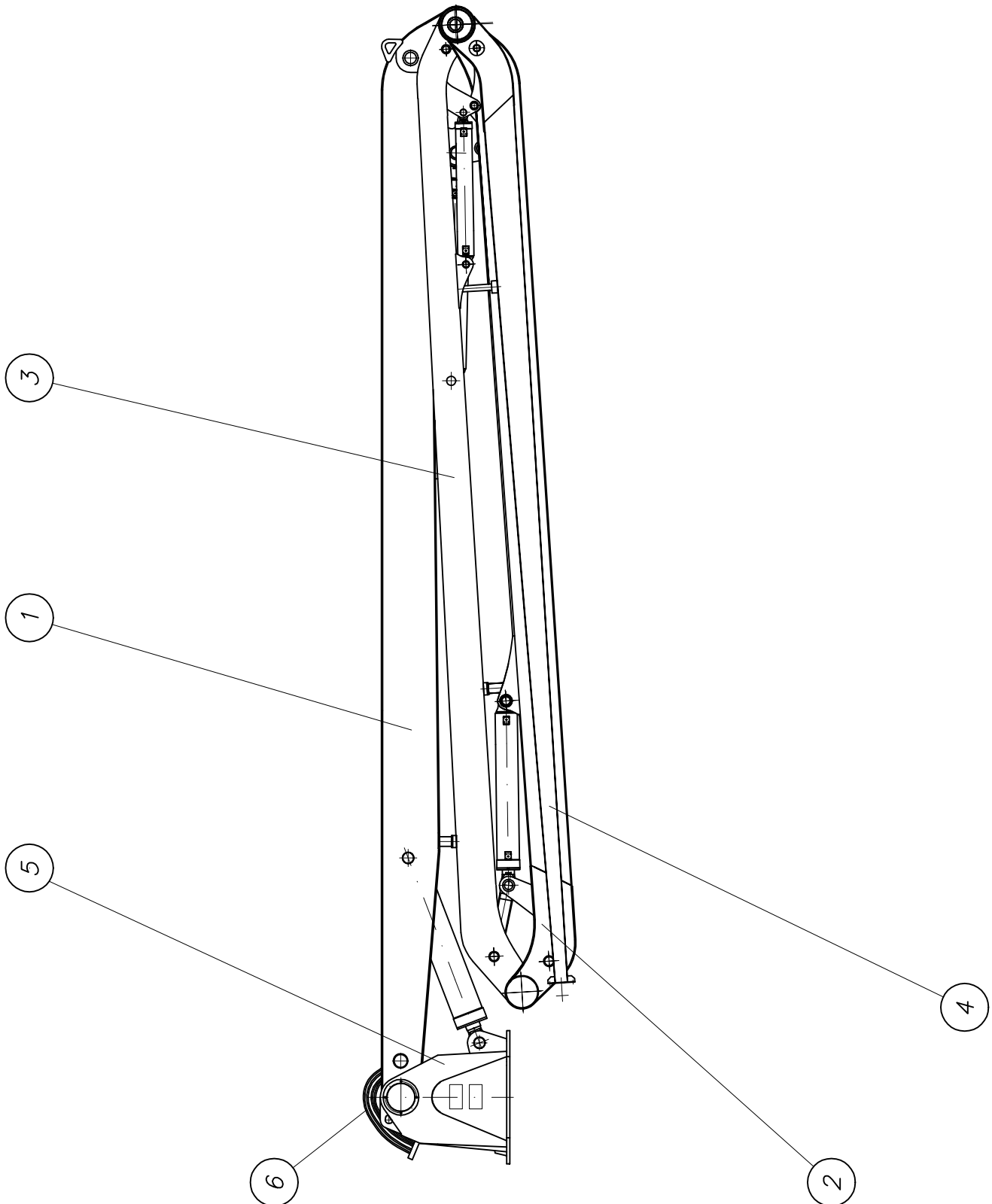



# PARTS LIST

part list	description	created	index	valid from	valid to	
B661025	distribution boom 36.4	27.11.03 Mi				
pos	description stock	ident-no dimensions	DIN material	index	weighth Kg	quantity unit
1	boom arm 1 cpl. own parts list	B661041		a 10.02.05		1,00 Stk
2	boom arm 2 cpl. own parts list	B661051				1,00 Stk
3	boom arm 3 cpl. own parts list	B661061		c 10.02.05		1,00 Stk
4	boom arm 4 cpl. own parts list	B661071				1,00 Stk
5	rotating head unit own parts list	B681002				1,00 Stk
6	piping diagram boom own parts list	B711065		c 02.09.03	77,00	1,00 Stk

Mastarm 1 kpl.  
element 1 cpl.

B 66 1 041a

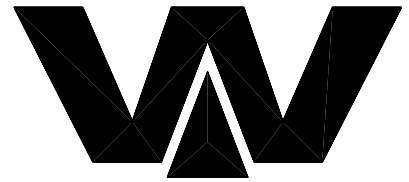

Waitzinger  
Baumaschinen GmbH

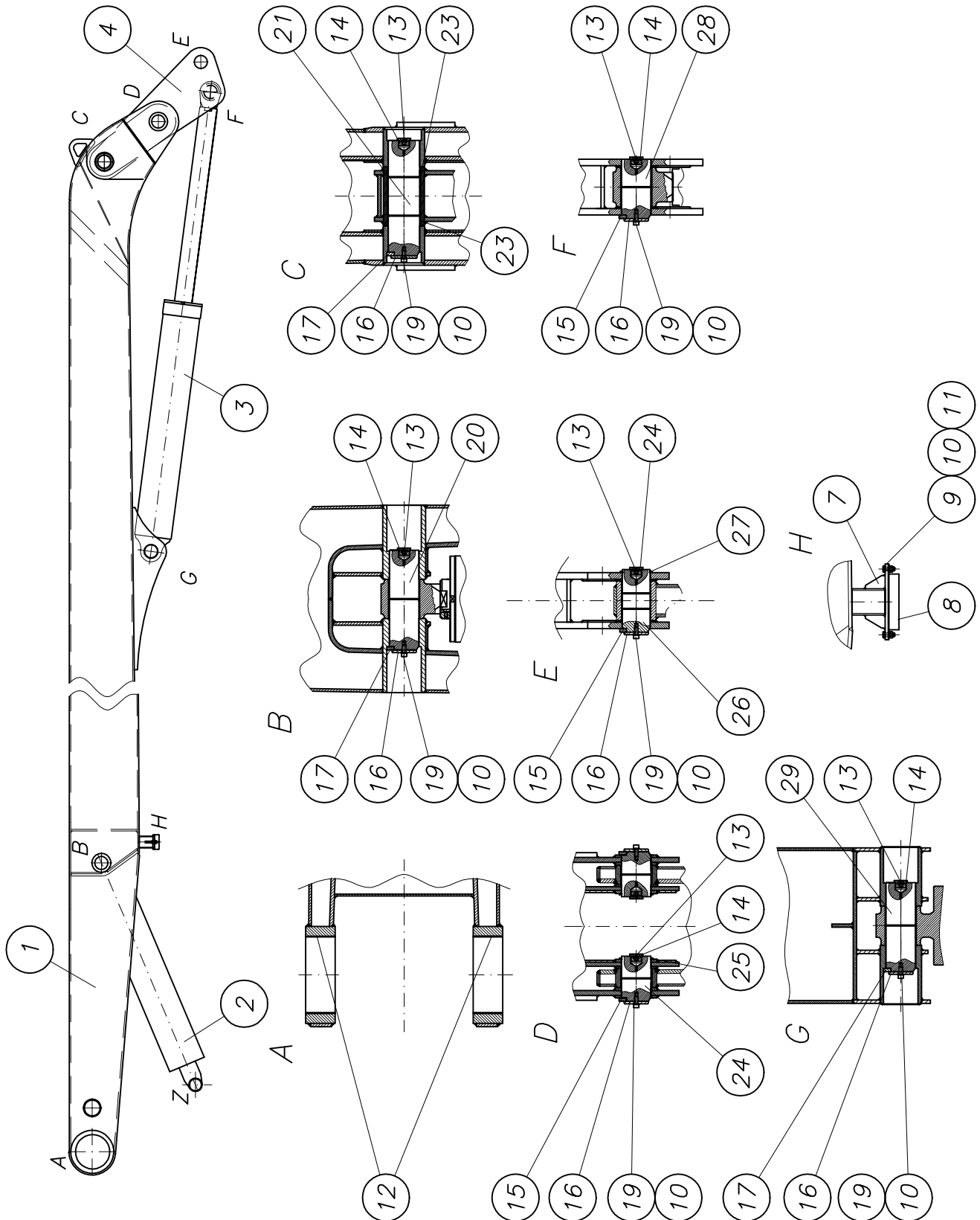



## PARTS LIST

part list	description	created	index	valid from	valid to	
B661041	boom arm 1 cpl. own parts list	27.09.01 Mi	a	10.02.05		
pos	description stock	ident-no dimensions	DIN material	index	weigh Kg	quantity unit
1	boom arm 1 cpl. own parts list	B671100				1,00 Stk
2	boom cylinder A cpl. with pipes own parts list	B660130				1,00 Stk
3	boom cylinder B cpl. with pipes own parts list	B660131				1,00 Stk
4	beam "B" cpl. processing drawing own parts list	B671610		a 26.01.05	98,00	1,00 Stk
7	holder for rubber buffer arm 1 cpl. own parts list	B661080			3,30	1,00 Stk
8	rubber cushion	WAI106715				1,00 Stk
9	hexagon bolt M 10 x 30	WAI101553			0,03	2,00 Stk
10	spring washer A10	WAI102070			0,00	9,00 Stk
11	hex. nut M10 DIN985 8.	WAI102125			0,01	2,00 Stk
12	bushing CD230.235090	WAI106020				2,00 Stk
13	grease nipple H1 M10 X 1 DIN 71412	WAI100805			0,01	7,00 Stk
14	locking screw M33x2 own parts list	B660085			0,10	7,00 Stk
15	pin holder	B660086 FI 25x10x80	1017 S235J2G3		0,15	4,00 Stk
16	washer	B660087 BI 8xd80	1543/EN10029 S235J2G3		0,20	7,00 Stk
17	pin holder	B660088 BI 10x22x70	1543/EN10029 S235J2G3		0,10	3,00 Stk
19	cylinder head screw M 10 x 25	WAI106654				7,00 Stk
20	pin 90 x 304	B660115 Rd 95x310	1013 42CrMo4V	a 31.07.02	15,00	1,00 Stk
21	pin 95 x 350	B660113 Rd 100x355	1013 42CrMo4V	a 31.07.02	19,00	1,00 Stk
23	bushing 90 x 100 x 60	WAI106019				2,00 Stk
24	pin 90 x 137	B660118 Rd 95x141	1013 42CrMo4V	b 31.07.02	7,00	2,00 Stk
25	retaining ring A 90x4 DIN471	WAI106974			0,02	2,00 Stk



## PARTS LIST

<b>part list</b>	<b>description</b>	<b>created</b>	<b>index</b>	<b>valid from</b>	<b>valid to</b>	
B661041	boom arm 1 cpl.	27.09.01 Mi	a	10.02.05		
<b>pos</b>	<b>description stock</b>	<b>ident-no dimensions</b>	<b>DIN material</b>	<b>index</b>	<b>weigh Kg</b>	<b>quantity unit</b>
26	pin 85 x 190	B660110 Rd 90x195	1013 42CrMo4V	a 31.07.02	8,50	1,00 Stk
27	retaining ring A 85x4 DIN471	WAI106975			0,02	1,00 Stk
28	pin 90 x 180	B660112 Rd 95x180	1013 42CrMo4V	a 31.07.02	10,00	1,00 Stk
29	pin 90 x 271	B660114 Rd 95x275	1013 42CrMo4V	a 31.07.02	14,00	1,00 Stk

# Mastarm 1

## boom element 1

B 67 1 100

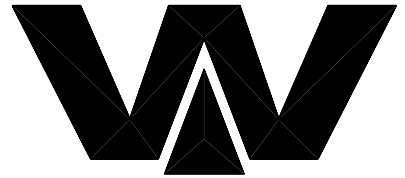

Waitzinger  
Baumaschinen GmbH

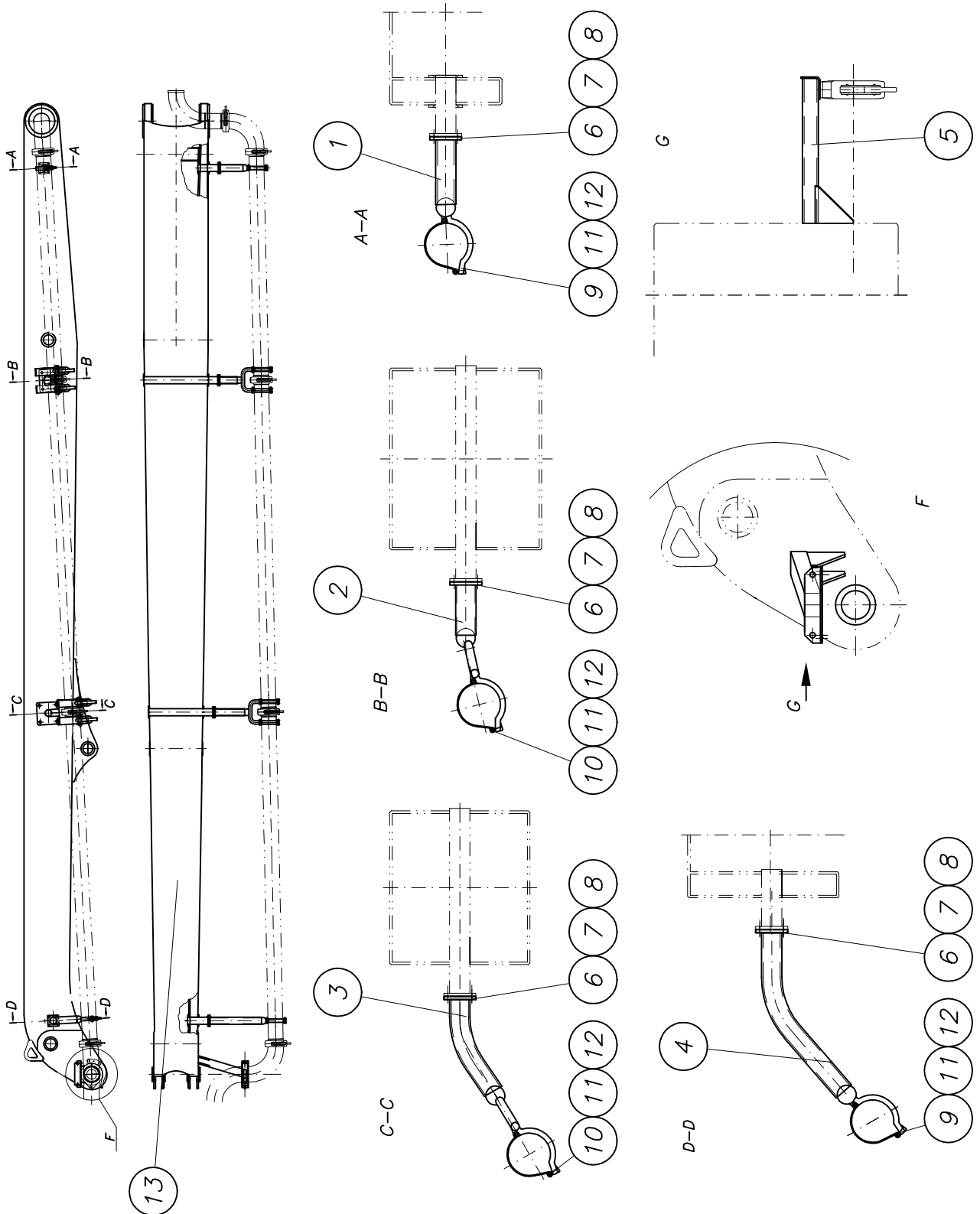



## PARTS LIST

part list	description	created	index	valid from	valid to	
B671100	boom arm 1 cpl.	30.11.01 Mi				
pos	description stock	ident-no dimensions	DIN material	index	weigh Kg	quantity unit
1	holder 1 cpl., element 1 own parts list	B641040			2,30	1,00 Stk
2	holder 2 cpl., element 1 own parts list	B641044			2,10	1,00 Stk
3	holder 3 cpl., element 1 own parts list	B641046			3,00	1,00 Stk
4	holder 4 cpl., element 1 own parts list	B641050			4,70	1,00 Stk
5	holder 5 cpl., element 1 own parts list	B641039		a 22.04.05	5,70	1,00 Stk
6	hexagon bolt M 10 x 35	WAI101705			0,03	16,00 Stk
7	washer 10.5	WAI101559			0,00	16,00 Stk
8	nut M10 DIN 934	WAI101556			0,01	16,00 Stk
9	pipe holder cpl. own parts list	WAI107108				2,00 Stk
10	pipe holder cpl. own parts list	WAI107109				2,00 Stk
11	conical spring washer 12 mm	WAI102877				6,00 Stk
12	hex. nut M12 DIN 985 8. VERZ.	WAI101626				6,00 Stk
13	boom arm 1 processing cpl. own parts list	B671101		a 18.12.02		1,00 Stk



*Mastzylinder A kpl.*  
*boom cylinder A cpl.*

*B 66 0 130*

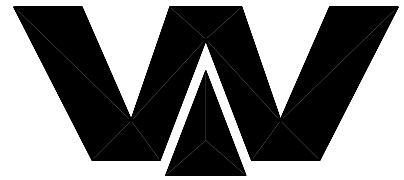

Waitzinger  
Baumaschinen GmbH

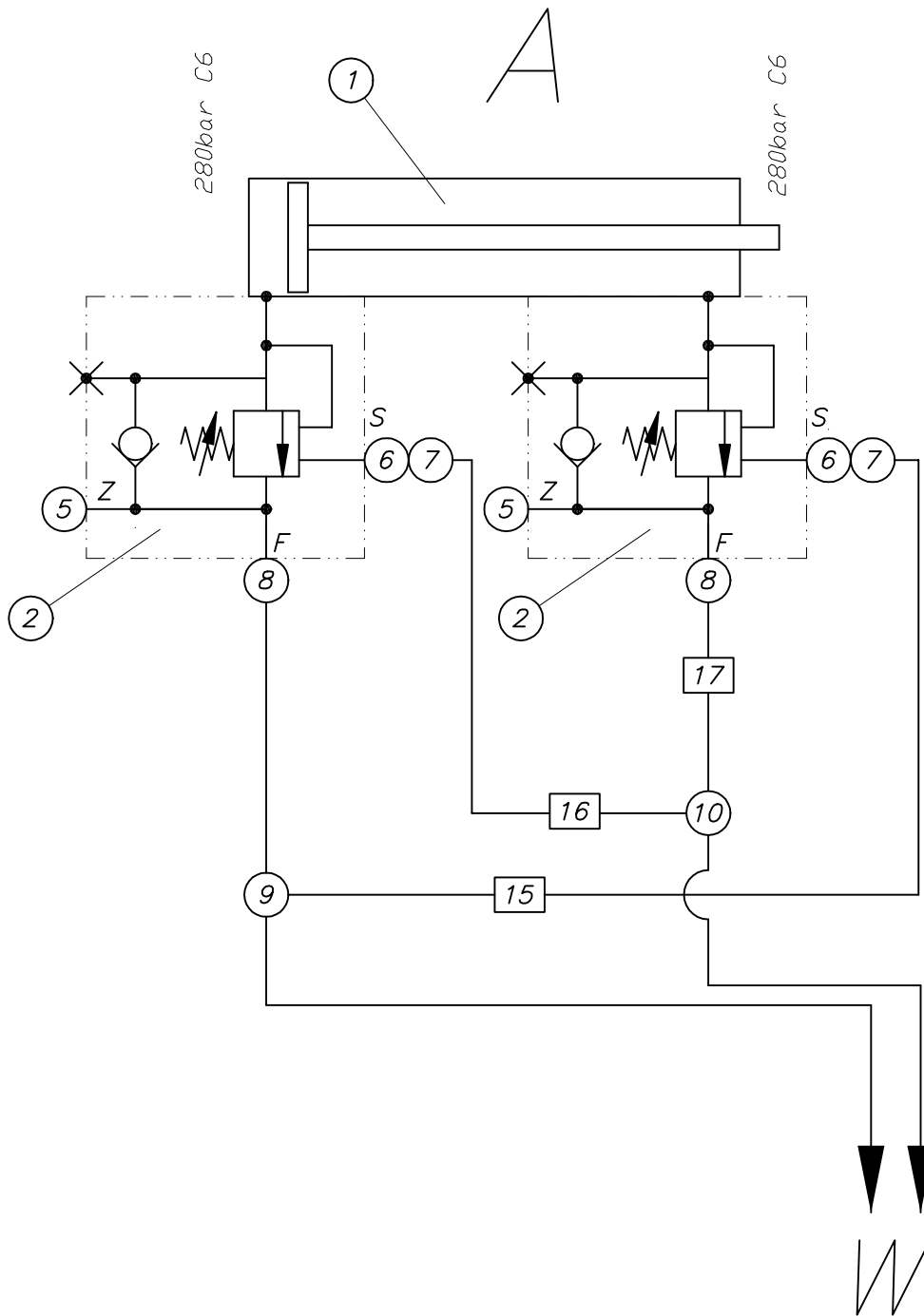



# PARTS LIST

part list	description	created	index	valid from	valid to	
B660130	boom cylinder A cpl. with pipes	12.09.03 Mi				
pos	description stock	ident-no dimensions	DIN material	index	weighth Kg	quantity unit
1	boom cylinder for 36-mtr., section A own parts list	WAI106189			342,00	1,00 Stk
2	locking valve 280 bar	WAI106935				2,00 Stk
5	locking screw G 1/4	WAI100520				2,00 Stk
6	straight male stud couplings L12	WAI101383				2,00 Stk
7	swivel elbow L12	WAI100590				2,00 Stk
8	straight male stud couplings L12	WAI101386				2,00 Stk
9	swivel barrel tee L12	WAI101325				1,00 Stk
10	tee coupling L12	WAI100598				1,00 Stk
15	pipe	WAI108452				1,00 Stk
16	pipe	WAI108453				1,00 Stk
17	hydr. pipe 12 x 2	WAI102022			0,49	0,20 Mtr

*Mastzylinder A*  
*boom cylinder A*

*WAI 106189*

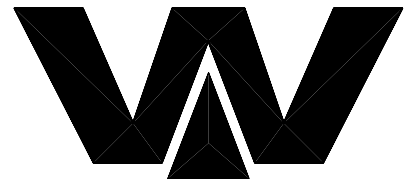

*Waitzinger*  
*Baumaschinen GmbH*

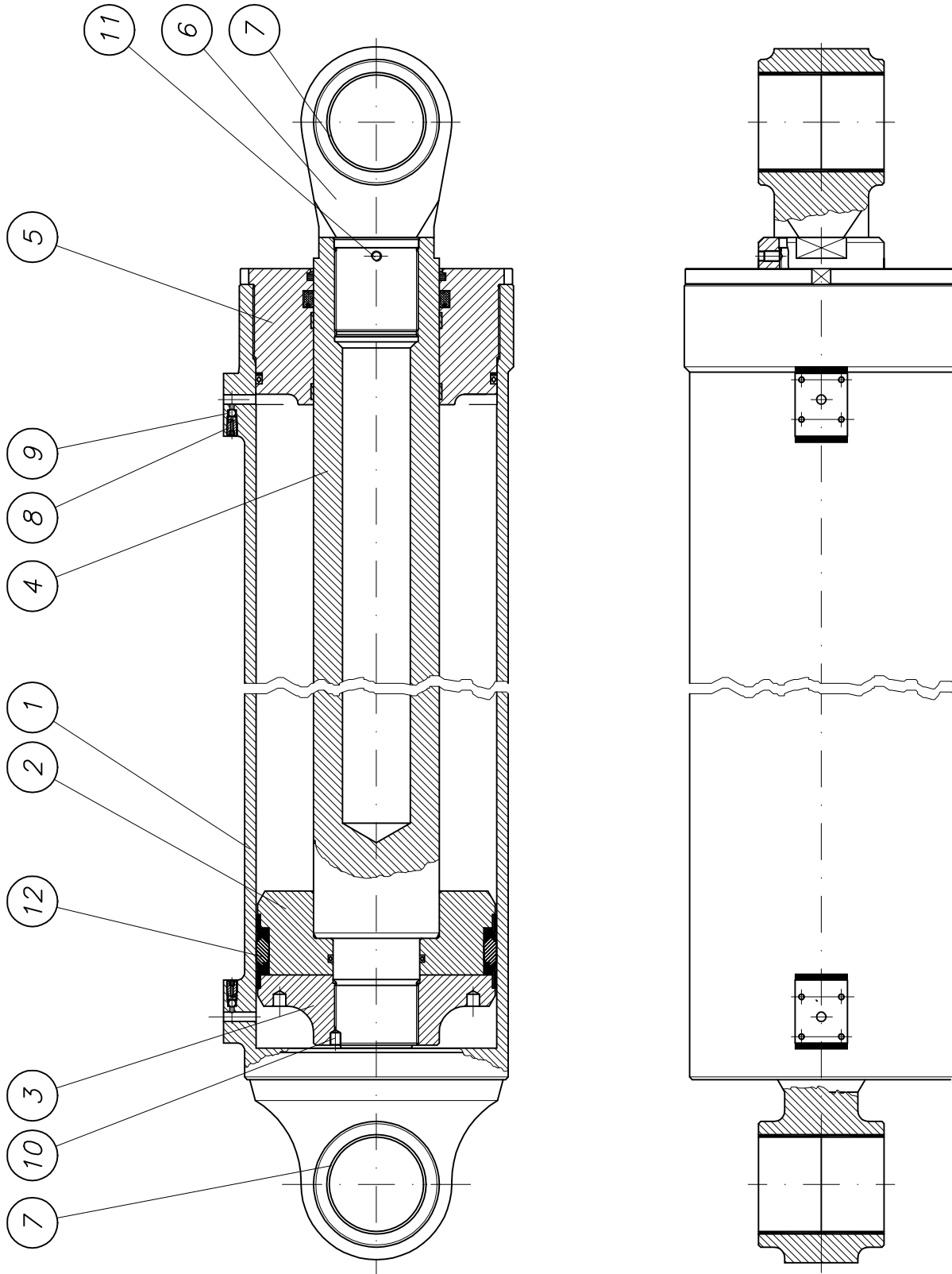



## PARTS LIST

part list	description	created	index	valid from	valid to	
WAI106189	boom cylinder for 36-mtr., section A	09.03.01 Mi				
pos	description stock	ident-no dimensions	DIN material	index	weighth Kg	quantity unit
1	cylinder	WAI106716				1,00 Stk
2	piston	WAI106717				1,00 Stk
3	piston nut	WAI106718				1,00 Stk
4	piston rod	WAI106719				1,00 Stk
5	piston guide	WAI106720				1,00 Stk
6	piston head	WAI106721				1,00 Stk
7	bushing 90 x 95 x 60	WAI106018				4,00 Stk
8	Valve	WAI106722				2,00 Stk
9	steel ball	WAI106723				2,00 Stk
10	set screw	WAI106724				1,00 Stk
11	set screw	WAI106725				1,00 Stk
12	sealing set for 1st. boom cylinder	WAI104033				1,00 Stk

Mastzylinder B kpl.  
boom cylinder B cpl.

B 66 0 131



Waitzinger  
Baumaschinen GmbH

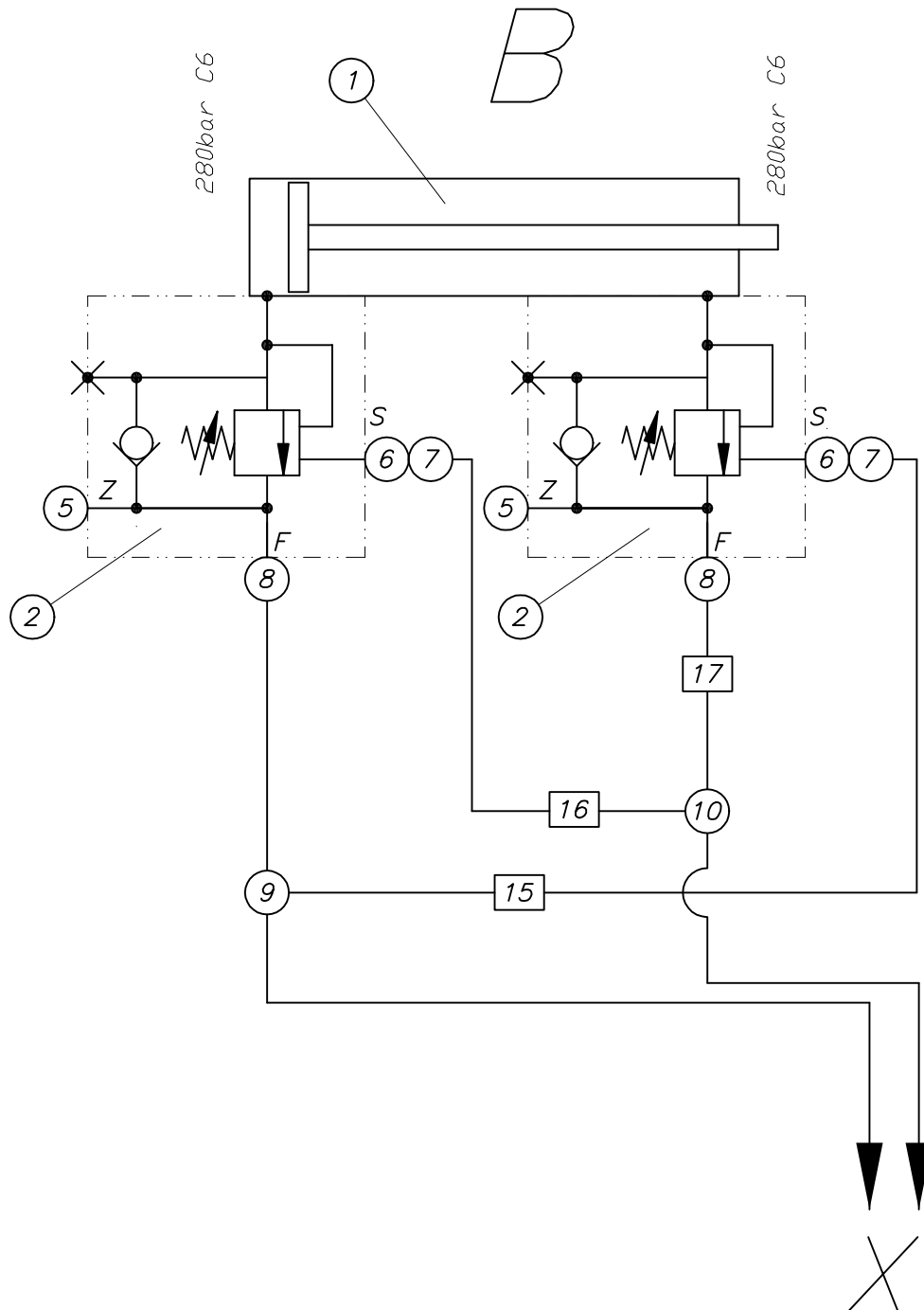



# PARTS LIST

part list	description	created	index	valid from	valid to	
B660131	boom cylinder B cpl. with pipes	12.09.03 Mi				
pos	description stock	ident-no dimensions	DIN material	index	weighth Kg	quantity unit
1	boom cylinder for 36-mtr., section B own parts list	WAI106190				1,00 Stk
2	locking valve 280 bar	WAI106935				2,00 Stk
5	locking screw G 1/4	WAI100520				2,00 Stk
6	straight male stud couplings L12	WAI101383				2,00 Stk
7	swivel elbow L12	WAI100590				2,00 Stk
8	straight male stud couplings L12	WAI101386				2,00 Stk
9	swivel barrel tee L12	WAI101325				1,00 Stk
10	tee coupling L12	WAI100598				1,00 Stk
15	pipe	WAI108454				1,00 Stk
16	pipe	WAI108455				1,00 Stk
17	hydr. pipe 12 x 2	WAI102022			0,49	0,20 Mtr

*Mastzylinder B*  
*boom cylinder B*

*WAI 106190*

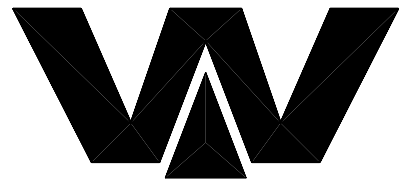

*Waitzinger*  
*Baumaschinen GmbH*

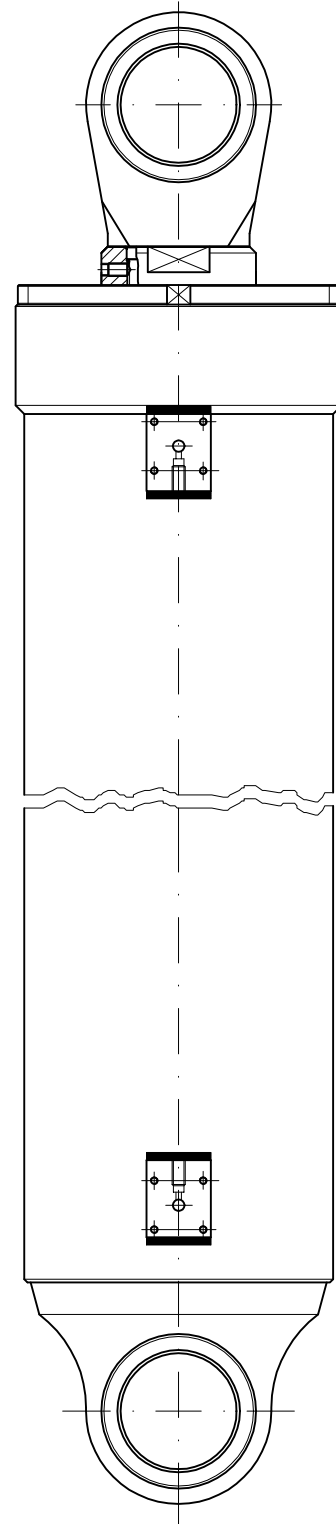
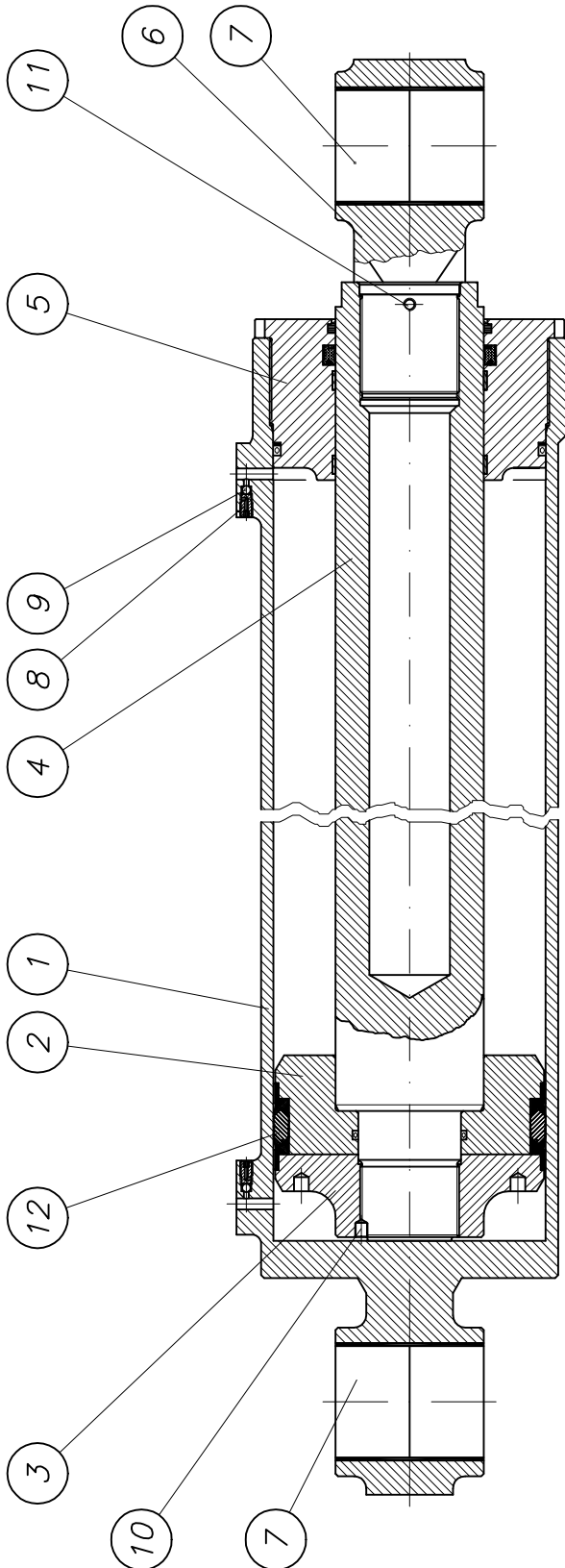



## PARTS LIST

part list	description	created	index	valid from	valid to	
WAI106190	boom cylinder for 36-mtr., section B	09.03.01 Mi				
pos	description stock	ident-no dimensions	DIN material	index	weighth Kg	quantity unit
1	cylinder	WAI106727				1,00 Stk
2	piston	WAI106728				1,00 Stk
3	piston nut	WAI106729				1,00 Stk
4	piston rod	WAI106730				1,00 Stk
5	piston guide	WAI106731				1,00 Stk
6	piston head	WAI106721				1,00 Stk
7	bushing 90 x 95 x 60	WAI106018				4,00 Stk
8	Valve	WAI106722				2,00 Stk
9	steel ball	WAI106723				2,00 Stk
10	set screw	WAI106724				1,00 Stk
11	set screw	WAI106725				1,00 Stk
12	sealing set for 2nd. boom cylinder own parts list	WAI104034				1,00 Stk



Mastarm 2 kpl.  
element 2 cpl.

B 66 1 051

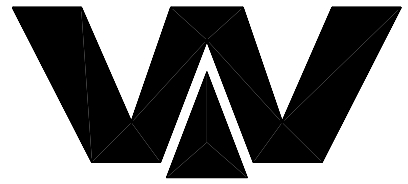

Waitzinger  
Baumaschinen GmbH

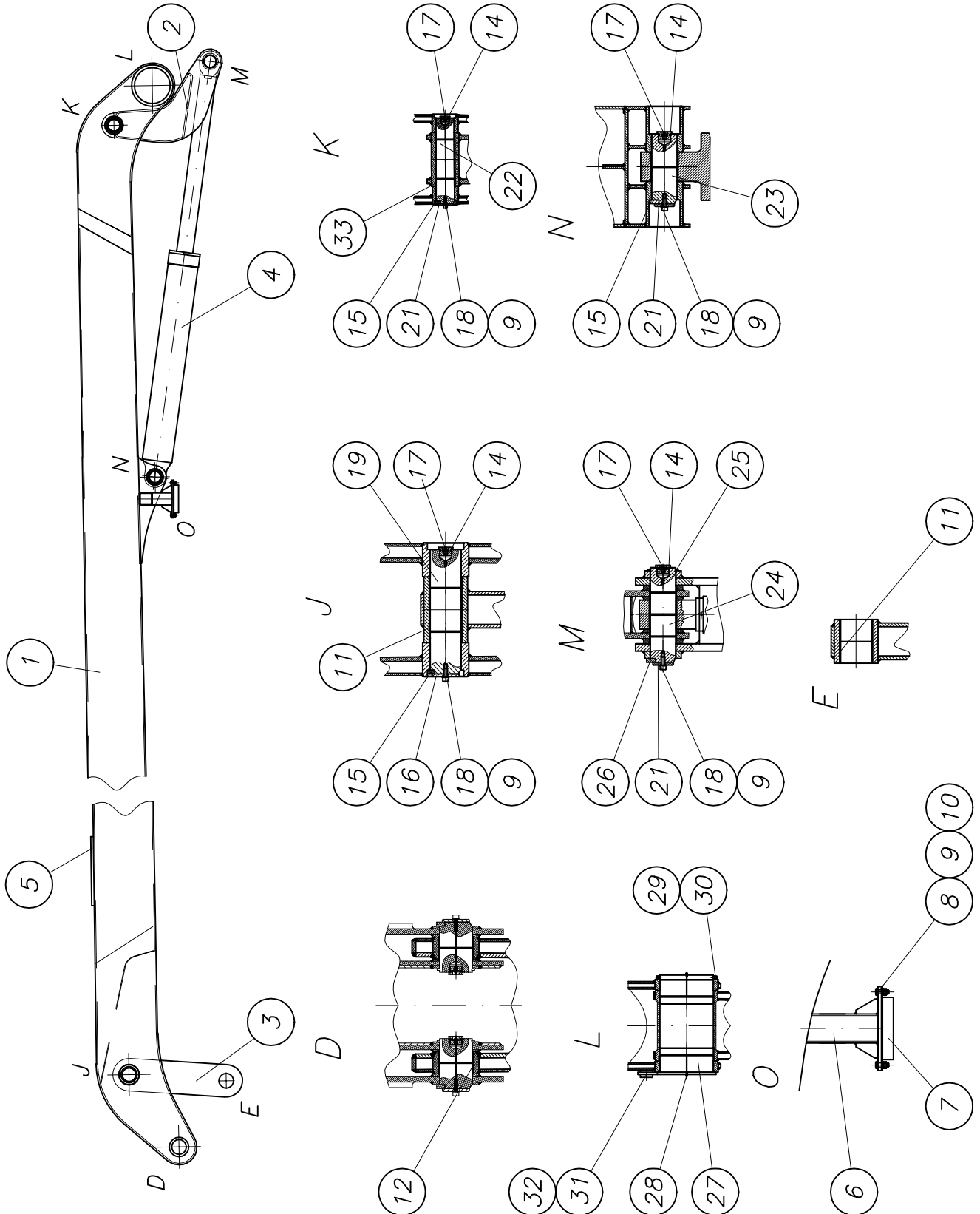



## PARTS LIST

part list	description	created	index	valid from	valid to	
B661051	boom arm 2 cpl.	05.12.01 Mi				
pos	description stock	ident-no dimensions	DIN material	index	weigh Kg	quantity unit
1	boom arm 2 cpl. own parts list	B671203		a 07.03.03		1,00 Stk
2	Lever C cpl. own parts list	B671620			75,00	1,00 Stk
3	forcing rod B cpl. own parts list	B671710			45,00	1,00 Stk
4	boom cylinder C cpl. with pipes own parts list	B660132			165,00	1,00 Stk
5	reinforcement	B660092 Bl 8x250x350	1543/EN10029 S235J2G3		0,54	1,00 Stk
6	holder for rubber buffer arm 2 cpl. own parts list	B661085			4,20	1,00 Stk
7	rubber cushion	WAI106715				1,00 Stk
8	hexagon bolt M 10 x 30	WAI101553			0,03	2,00 Stk
9	spring washer A10	WAI102070			0,00	6,00 Stk
10	hex. nut M10 DIN985 8.	WAI102125			0,01	2,00 Stk
11	bushing 85 x 90 x 60	WAI106017			0,20	4,00 Stk
12	bushing 90 x 95 x 60	WAI106018				2,00 Stk
14	locking screw M33x2 own parts list	B660085			0,10	4,00 Stk
15	pin holder	B660088 Bl 10x22x70	1543/EN10029 S235J2G3		0,10	3,00 Stk
16	washer	B660087 Bl 8xd80	1543/EN10029 S235J2G3		0,20	1,00 Stk
17	grease nipple H1 M10 X 1 DIN 71412	WAI100805			0,01	4,00 Stk
18	cylinder head screw M 10 x 25	WAI106654				4,00 Stk
19	pin 85 x 340	B660111 Rd 90x345	1013 42CrMo4V	a 31.07.02	15,00	1,00 Stk
21	washer	B660089 Bl 8xd62	1543/EN10029 S235J2G3		0,20	3,00 Stk
22	pin 75 x 350	B660109 Rd 80x355	1013 42CrMo4V	a 31.07.02	12,00	1,00 Stk
23	pin 70 x 190	B660107 Rd 75x195	1013 42CrMo4V	a 31.07.02	5,50	1,00 Stk



## PARTS LIST

part list	description	created	index	valid from	valid to	
B661051	boom arm 2 cpl.	05.12.01 Mi				
pos	description stock	ident-no dimensions	DIN material	index	weigh Kg	quantity unit
24	pin 70 x 259	B660106 Rd 75x264	1013 42CrMo4V	a 31.07.02	8,00	1,00 Stk
25	retaining ring A 70x4 DIN471	WAI106981			0,02	1,00 Stk
26	pin holder	B660086 FI 25x10x80	1017 S235J2G3		0,15	1,00 Stk
27	pin 220x 400	B660108 Rohr 244.5x25x4	2448 S355J2G3			1,00 Stk
28	grease nipple	WAI102885				4,00 Stk
29	threaded ring	WAI105378				1,00 Stk
30	set screw M 6 x 8	WAI103646				2,00 Stk
31	pin protection	B660123 Bl 10x100x148	1543/EN10029 S355J2G3		0,45	1,00 Stk
32	pipe	B660124 Rohr 51x6.3x30	2448 S355J2G3		0,20	1,00 Stk
33	bushing 75 x 80 x 60	WAI106016				2,00 Stk

Mastarm 2  
boom element 2

B 67 1 203a

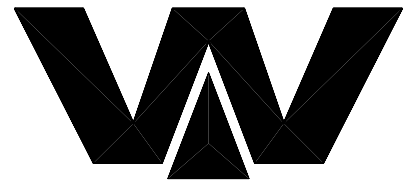

Waitzinger  
Baumaschinen GmbH

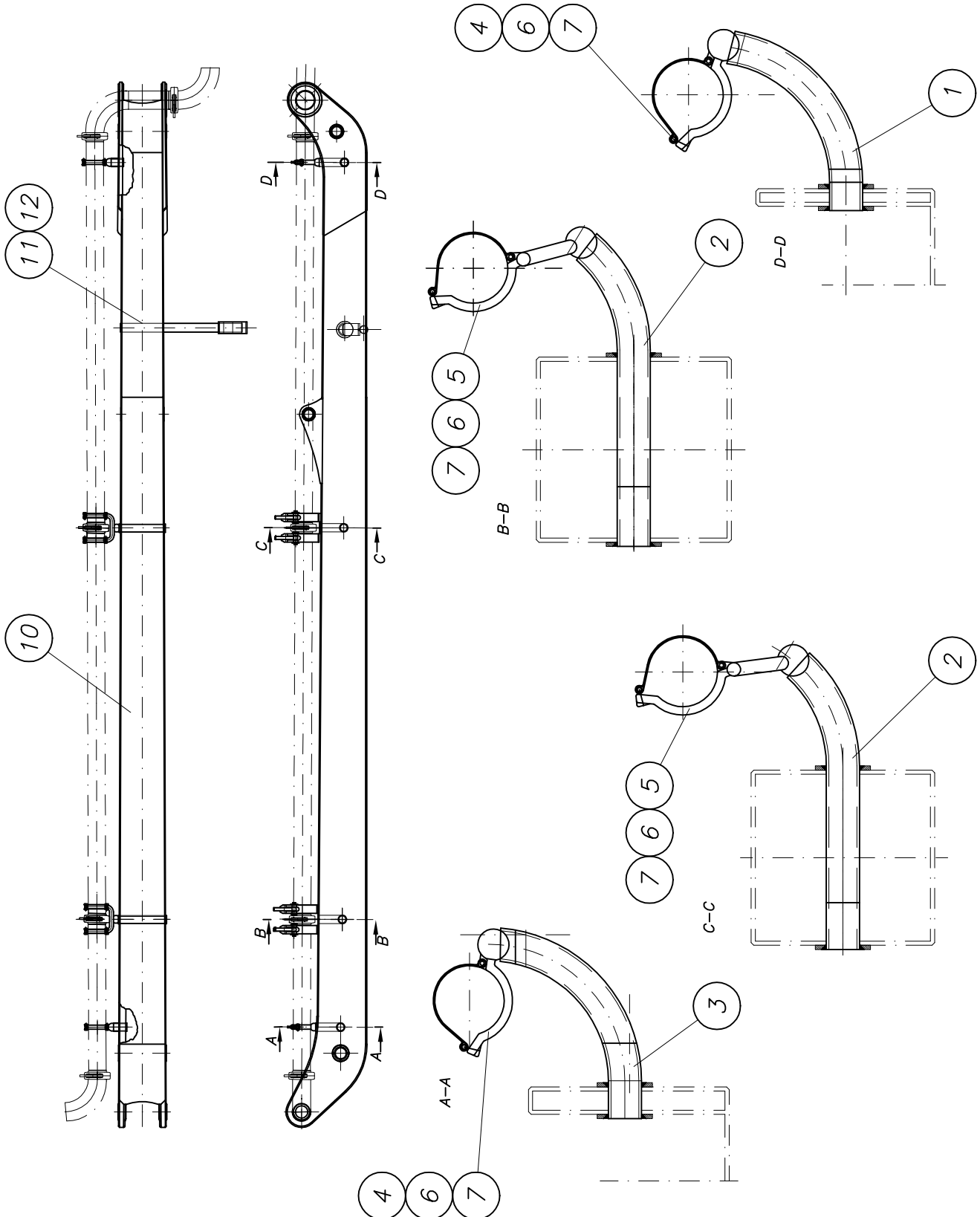



# PARTS LIST

part list	description	created	index	valid from	valid to	
B671203	boom arm 2 cpl.	05.12.01 Mi	a	07.03.03		
pos	description stock	ident-no dimensions	DIN material	index	weigh Kg	quantity unit
1	pipe 1, Element 2	B641041 Rohr 63.5x4x440	2448 S355J2G3	a 22.01.03	2,60	1,00 Stk
2	pipe 2+3, Element 2	B641047 Rohr 63.5x4x649	2448 S355J2G3	a 22.01.03	3,80	2,00 Stk
3	pipe 4, Element 2	B641049 Rohr 63.5x4x485	2448 S355J2G3	a 22.01.03	2,80	1,00 Stk
4	pipe holder cpl. own parts list	WAI107108				2,00 Stk
5	pipe holder cpl. own parts list	WAI107109				2,00 Stk
6	conical spring washer 12 mm	WAI102877				6,00 Stk
7	hex. nut M12 DIN 985 8. VERZ.	WAI101626				6,00 Stk
10	boom arm 2 processing cpl. own parts list	B671204		a 12.12.02	810,00	1,00 Stk
11	pipe for arm holder 4 own parts list	B671250		a 12.01.04	10,00	1,00 Stk
12	rubber cushion	WAI107199			0,50	1,00 Stk





# PARTS LIST

part list	description	created	index	valid from	valid to	
B660132	boom cylinder C cpl. with pipes	12.09.03 Mi				
pos	description stock	ident-no dimensions	DIN material	index	weighth Kg	quantity unit
1	boom cylinder for 36-mtr., section C own parts list	WAI106191				1,00 Stk
2	locking valve 320 bar	WAI106258				2,00 Stk
5	locking screw G 1/4	WAI100520				2,00 Stk
6	straight male stud couplings L12	WAI101383				2,00 Stk
7	swivel elbow L12	WAI100590				2,00 Stk
8	straight male stud couplings L12	WAI101386				2,00 Stk
9	swivel barrel tee L12	WAI101325				1,00 Stk
10	tee coupling L12	WAI100598				1,00 Stk
15	pipe	WAI108456				1,00 Stk
16	pipe	WAI108457				1,00 Stk
17	hydr. pipe 12 x 2	WAI102022			0,49	0,20 Mtr

*Mastzylinder C*  
*boom cylinder C*

*WAI 106191*

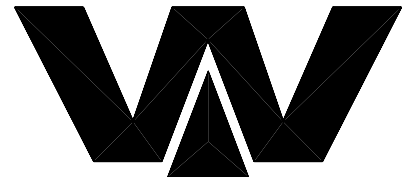

*Waitzinger*  
*Baumaschinen GmbH*

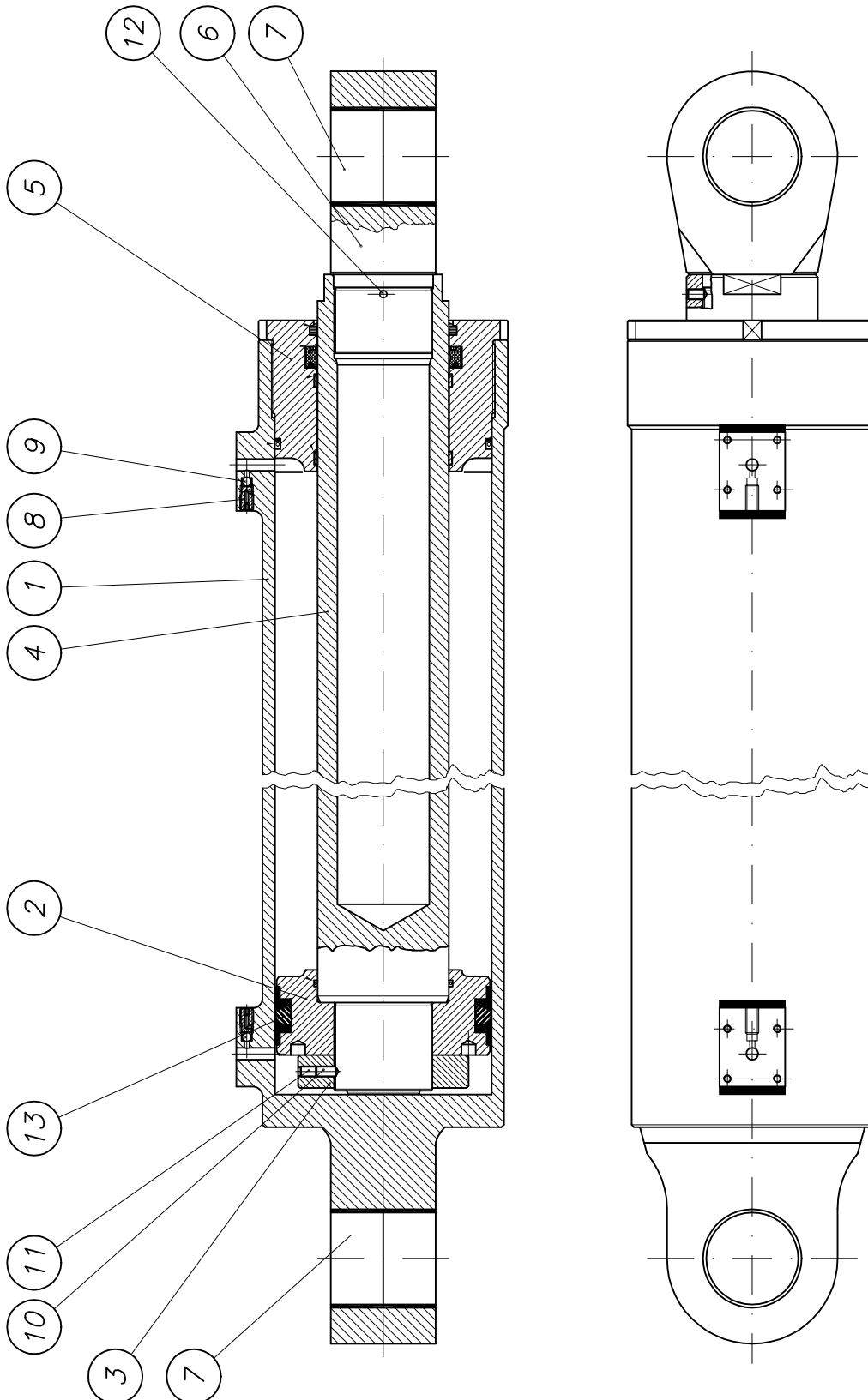





## PARTS LIST

part list	description	created	index	valid from	valid to	
WAI106191	boom cylinder for 36-mtr., section C	09.03.01 Mi				
pos	description stock	ident-no dimensions	DIN material	index	weighth Kg	quantity unit
1	cylinder	WAI106732				1,00 Stk
2	piston	WAI106733				1,00 Stk
3	piston nut	WAI106734				1,00 Stk
4	piston rod	WAI106735				1,00 Stk
5	piston guide	WAI106736				1,00 Stk
6	piston head	WAI106737				1,00 Stk
7	bushing 70 x 75 x 40	WAI106014				4,00 Stk
8	Valve	WAI106722				2,00 Stk
9	steel ball	WAI106723				2,00 Stk
10	set screw	WAI106738				1,00 Stk
11	set screw	WAI106739				1,00 Stk
12	set screw	WAI106740				1,00 Stk
13	sealing set for 3th. boom cylinder own parts list	WAI104035				1,00 Stk

Mastarm 3 kpl.  
element 3 cpl.

B 66 1 061c

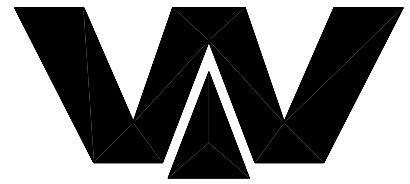

Waitzinger  
Baumaschinen GmbH

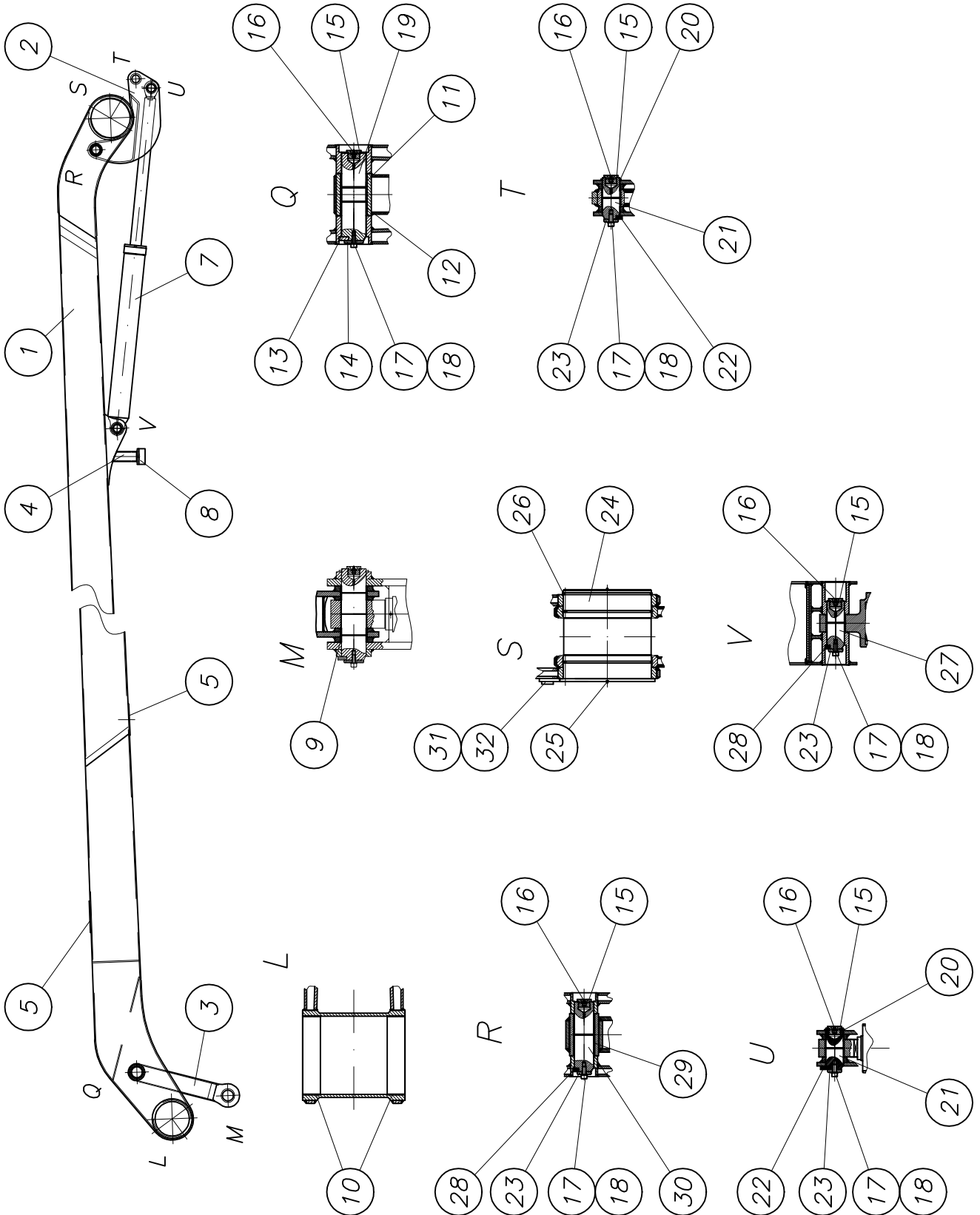



## PARTS LIST

part list	description	created	index	valid from	valid to	
B661061	boom arm 3 cpl. own parts list	06.12.01 Mi	c	10.02.05		
pos	description stock	ident-no dimensions	DIN material	index	weigh Kg	quantity unit
1	boom arm 3 cpl. own parts list	B671303				1,00 Stk
2	lever D cpl. own parts list	B671630		a 25.02.03	30,00	1,00 Stk
3	forcing rod C cpl. own parts list	B671720			25,00	1,00 Stk
4	holder for rubber buffer arm 3 cpl. own parts list	B661090			2,00	1,00 Stk
5	plate	B661091 Bl 5x200x280	1543/EN10029 ST37-2	a 17.06.02	2,00	2,00 Stk
7	boom cylinder D cpl. with pipes own parts list	B660133				1,00 Stk
8	rubber buffer 100 x 50	WAI103478				1,00 Stk
9	bushing 70 x 75 x 40	WAI106014				2,00 Stk
10	bushing 220 x 225 x 50	WAI106023				2,00 Stk
11	bushing 70 x 75 x 70	WAI106015				1,00 Stk
12	bushing 70 x 75 x 50	WAI106659				1,00 Stk
13	pin holder	B660088 Bl 10x22x70	1543/EN10029 S235J2G3		0,10	1,00 Stk
14	washer	B660089 Bl 8xd62	1543/EN10029 S235J2G3		0,20	1,00 Stk
15	locking screw M33x2 own parts list	B660085			0,10	5,00 Stk
16	grease nipple H1 M10 X 1 DIN 71412	WAI100805			0,01	5,00 Stk
17	cylinder head screw M 10 x 25	WAI106654				5,00 Stk
18	spring washer A10	WAI102070			0,00	5,00 Stk
19	pin 70 x 249	B660105 Rd 75x255	1013 42CrMo4V	b 05.11.03	7,50	1,00 Stk
20	locking ring	WAI106988				2,00 Stk
21	pin 50 x 117	B660103 Rd 55x122	1013 42CrMo4V	a 31.07.02	1,90	2,00 Stk
22	pin holder	B660086 Fl 25x10x80	1017 S235J2G3		0,15	2,00 Stk



## PARTS LIST

part list	description	created	index	valid from	valid to	
B661061	boom arm 3 cpl.	06.12.01 Mi	c	10.02.05		
pos	description stock	ident-no dimensions	DIN material	index	weigh Kg	quantity unit
23	washer	B660091 Bl 8xd42	1543/EN10029 S235J2G3		0,10	4,00 Stk
24	pin 250x 261	B660104 Rohr 273x25x265	2448 S355J2G3	a 17.06.02	23,50	1,00 Stk
25	grease nipple	WAI102885				4,00 Stk
26	circlip	WAI107121				1,00 Stk
27	pin	B660101 Rd 55x140	1013 42CrMo4V	a 31.07.02	2,00	1,00 Stk
28	pin holder	B660090 Bl 10x14x45	1543/EN10029 S235J2G3		0,10	2,00 Stk
29	bushing 55 x 60 x 60	WAI106013				2,00 Stk
30	pin 55 x 199	B660102 Rd 60x205	1013 42CrMo4V	a 31.07.02	3,50	1,00 Stk
31	pin protection	B660123 Bl 10x100x148	1543/EN10029 S355J2G3		0,45	1,00 Stk
32	pipe	B660124 Rohr 51x6.3x30	2448 S355J2G3		0,20	1,00 Stk

Mastarm 3  
boom element 3

B 67 1 303

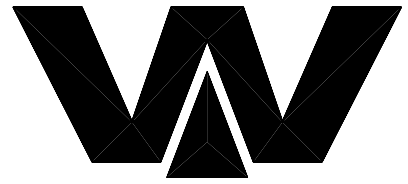

Waitzinger  
Baumaschinen GmbH

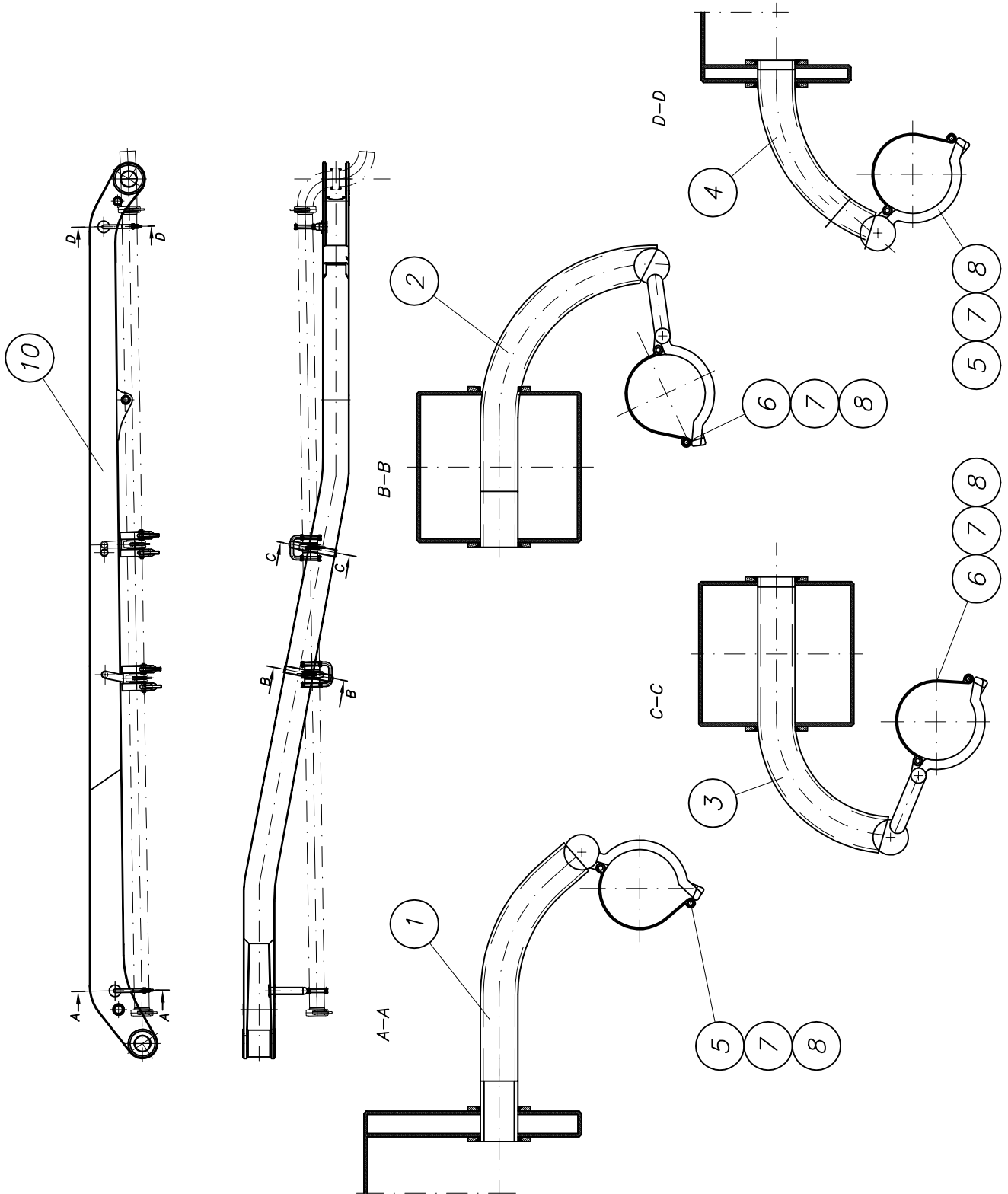



# PARTS LIST

part list	description	created	index	valid from	valid to	
B671303	boom arm 3 cpl.	05.12.01 Mi				
pos	description stock	ident-no dimensions	DIN material	index	weigh Kg	quantity unit
1	pipe 1, Element 3	B641051 Rohr 63.5x4x540	2448 S355J2G3	a 22.01.03	3,20	1,00 Stk
2	pipe 2, Element 3	B641052 Rohr 63.5x4x648	2448 S355J2G3	a 22.01.03	3,80	1,00 Stk
3	pipe 3, Element 3	B641053 Rohr 63.5x4x600	2448 S355J2G3	a 22.01.03	3,50	1,00 Stk
4	pipe 4, Element 3	B641054 Rohr 63.5x4x370	2448 S355J2G3	a 22.01.03	2,20	1,00 Stk
5	pipe holder cpl. own parts list	WAI107108				2,00 Stk
6	pipe holder cpl. own parts list	WAI107109				2,00 Stk
7	conical spring washer 12 mm	WAI102877				6,00 Stk
8	hex. nut M12 DIN 985 8. VERZ.	WAI101626				6,00 Stk
10	boom arm 3 processing cpl. own parts list	B671304		a 11.03.02		1,00 Stk

*Mastzylinder D kpl.*  
*boom cylinder D cpl.*

*B 66 0 133*

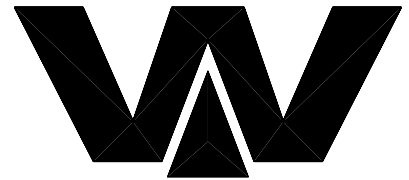

Waitzinger  
Baumaschinen GmbH

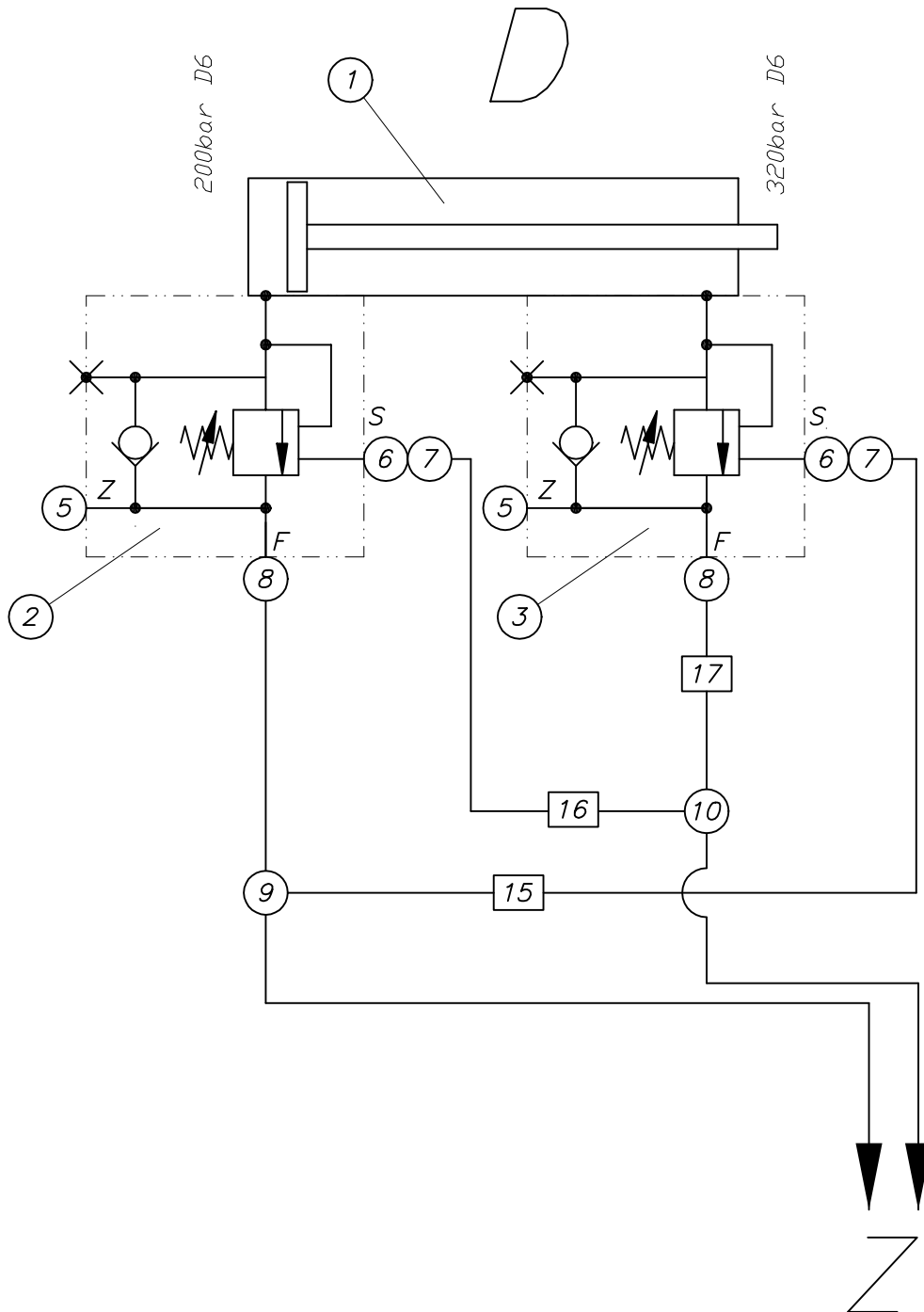



## PARTS LIST

part list	description	created	index	valid from	valid to	
B660133	boom cylinder D cpl. with pipes	12.09.03 Mi				
pos	description stock	ident-no dimensions	DIN material	index	weighth Kg	quantity unit
1	boom cylinder for 36-mtr., section D own parts list	WAI106192				1,00 Stk
2	locking valve 200 bar	WAI106259				1,00 Stk
3	locking valve 320 bar	WAI106258				1,00 Stk
5	locking screw G 1/4	WAI100520				2,00 Stk
6	straight male stud couplings L12	WAI101383				2,00 Stk
7	swivel elbow L12	WAI100590				2,00 Stk
8	straight male stud couplings L12	WAI101386				2,00 Stk
9	swivel barrel tee L12	WAI101325				1,00 Stk
10	tee coupling L12	WAI100598				1,00 Stk
15	pipe	WAI108458				1,00 Stk
16	pipe	WAI108459				1,00 Stk
17	hydr. pipe 12 x 2	WAI102022			0,49	0,20 Mtr



*Mastzylinder D*  
*boom cylinder D*

*WAI 106192*

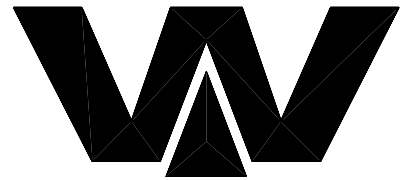

*Waitzinger*  
*Baumaschinen GmbH*

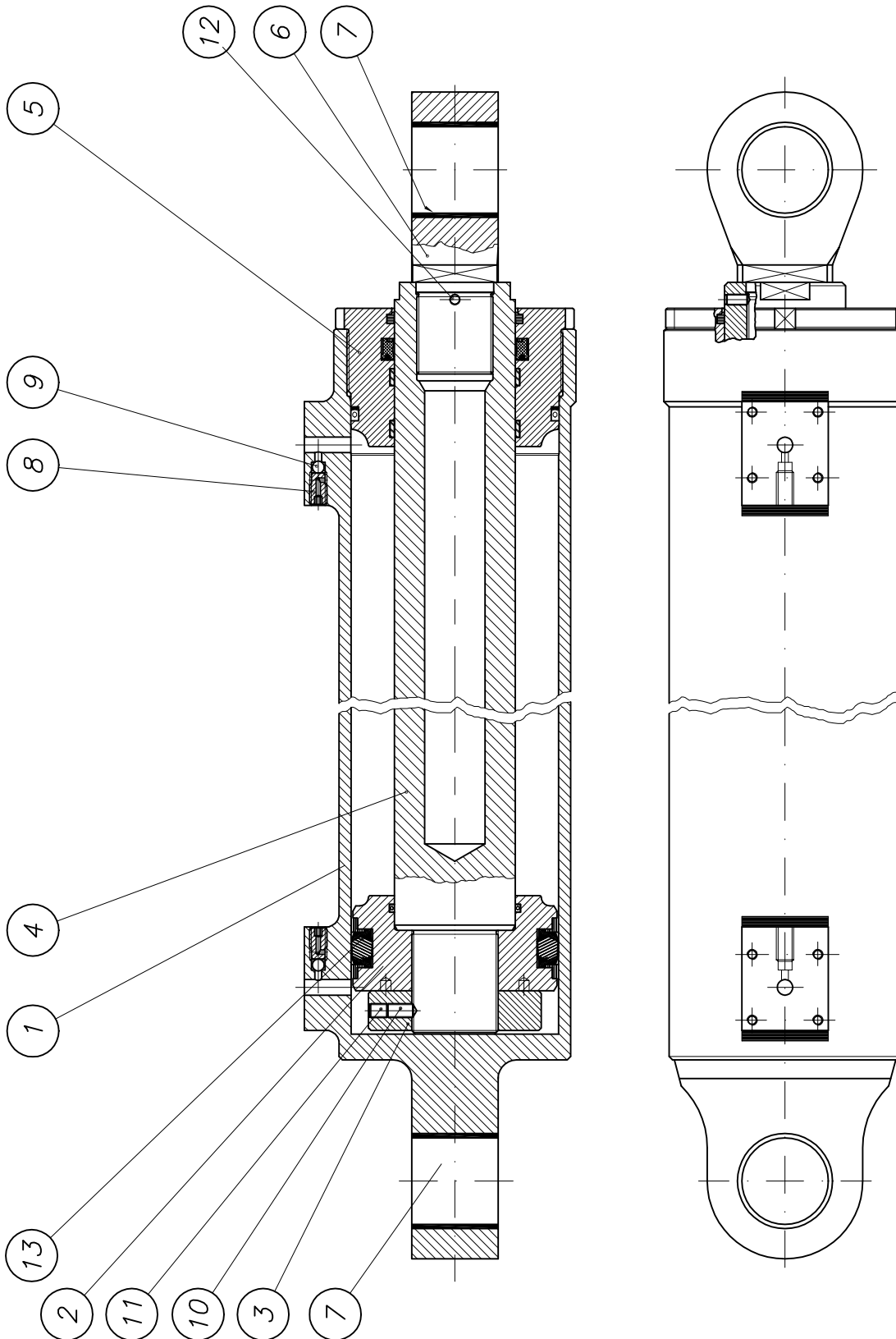



## PARTS LIST

part list	description	created	index	valid from	valid to	
WAI106192	boom cylinder for 36-mtr., section D	09.03.01 Mi				
pos	description stock	ident-no dimensions	DIN material	index	weighth Kg	quantity unit
1	cylinder	WAI106741				1,00 Stk
2	piston	WAI106742				1,00 Stk
3	piston nut	WAI106743				1,00 Stk
4	piston rod	WAI106744				1,00 Stk
5	piston guide	WAI106745				1,00 Stk
6	piston head	WAI106746				1,00 Stk
7	bushing 50 x 55 x 50	WAI106012				2,00 Stk
8	Valve	WAI106722				2,00 Stk
9	steel ball	WAI106723				2,00 Stk
10	set screw	WAI106738				1,00 Stk
11	set screw	WAI106739				1,00 Stk
12	set screw	WAI106747				1,00 Stk
13	sealing set for 4th. boom cylinder	WAI104036				1,00 Stk

Mastarm 4 kpl.  
element 4 cpl.

B 66 1 071

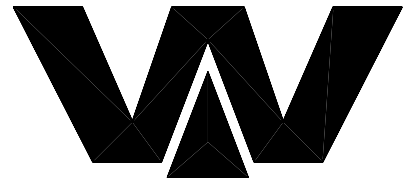

Waitzinger  
Baumaschinen GmbH

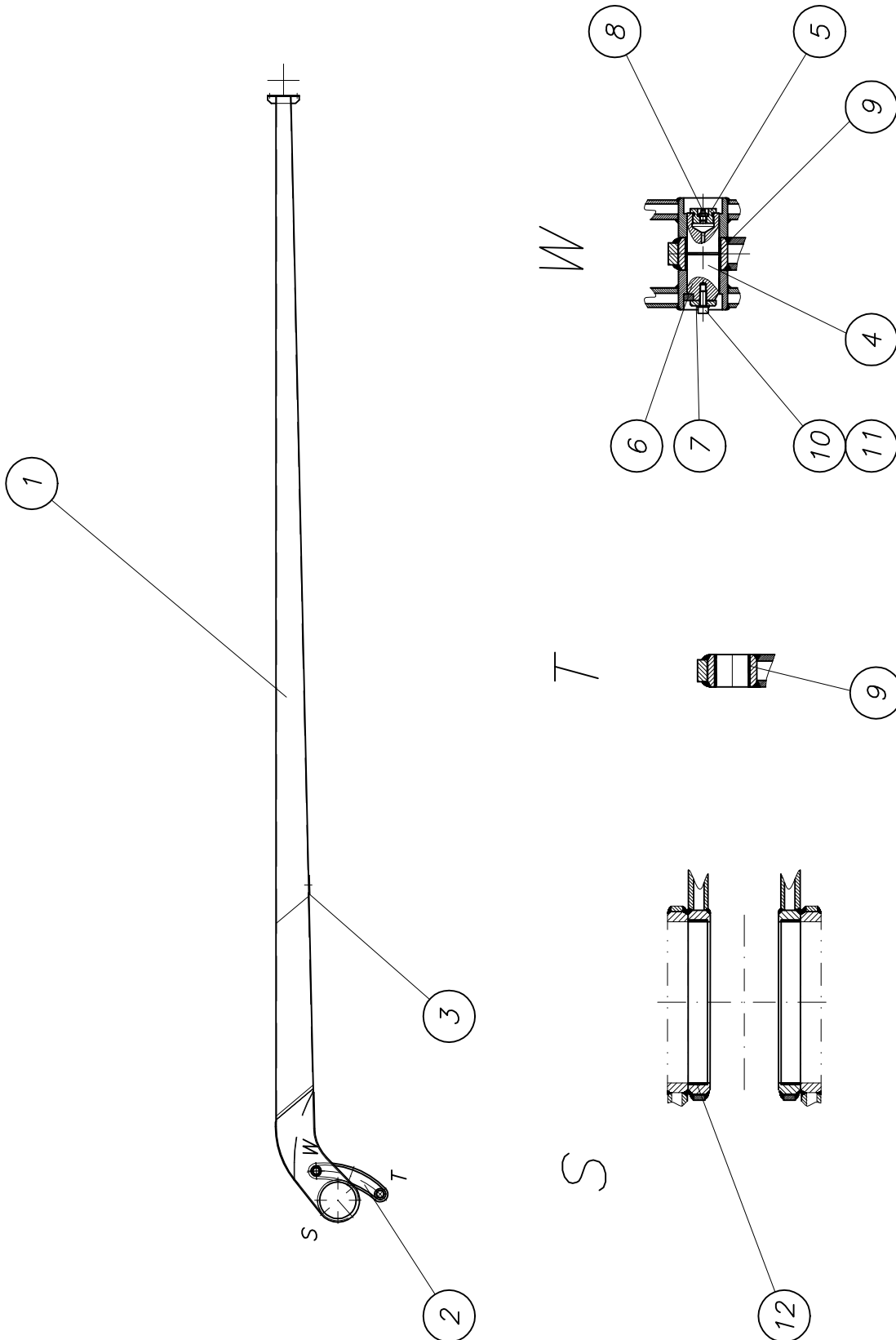



## PARTS LIST

part list	description	created	index	valid from	valid to	
B661071	boom arm 4 cpl.	06.12.01 Mi				
pos	description stock	ident-no dimensions	DIN material	index	weigh Kg	quantity unit
1	boom arm 4 cpl. own parts list	B671400		a 12.01.04		1,00 Stk
2	forcing rod D cpl. own parts list	B671730			14,00	1,00 Stk
3	plate	B661089 Bl 5x130x175	1543/EN10029 St37-2		0,80	1,00 Stk
4	pin	B660101 Rd 55x140	1013 42CrMo4V	a 31.07.02	2,00	1,00 Stk
5	locking screw M33x2 own parts list	B660085			0,10	1,00 Stk
6	pin holder	B660090 Bl 10x14x45	1543/EN10029 S235J2G3		0,10	1,00 Stk
7	washer	B660091 Bl 8xd42	1543/EN10029 S235J2G3		0,10	1,00 Stk
8	grease nipple H1 M10 X 1 DIN 71412	WAI100805			0,01	1,00 Stk
9	bushing 50 x 55 x 50	WAI106012				2,00 Stk
10	cylinder head screw M 10 x 25	WAI106654				1,00 Stk
11	spring washer A10	WAI102070			0,00	1,00 Stk
12	bushing 250 x 255 x 30	WAI106022			2,00	2,00 Stk

Mastarm 4  
boom element 4

B 67 1 400a

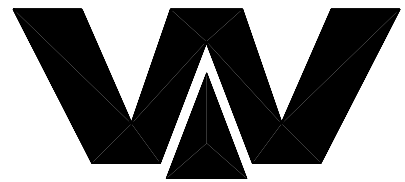

Waitzinger  
Baumaschinen GmbH

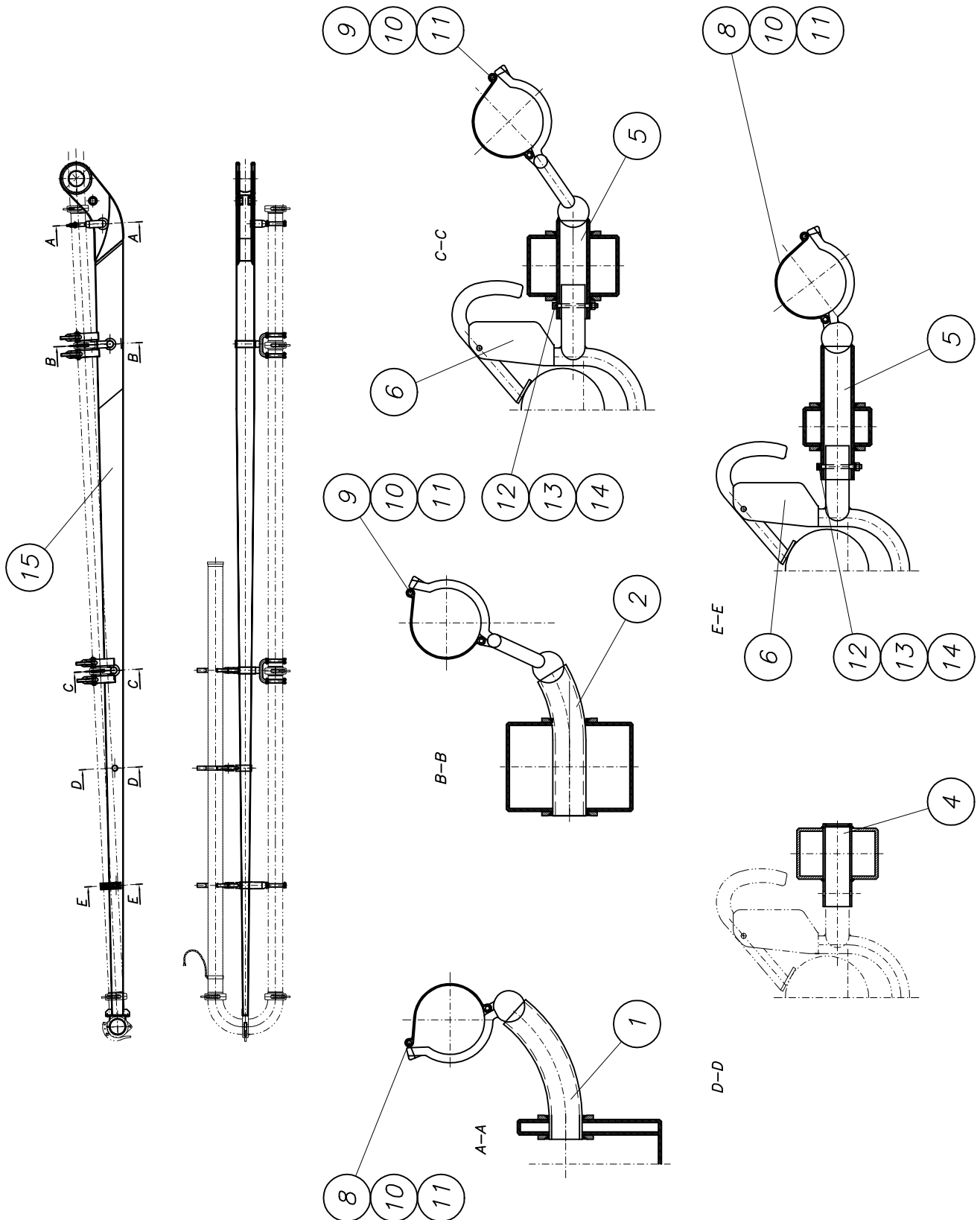



## PARTS LIST

part list	description	created	index	valid from	valid to	
B671400	boom arm 4 cpl.	03.12.01 Mi	a	12.01.04		
pos	description stock	ident-no dimensions	DIN material	index	weigh Kg	quantity unit
1	pipe 1, Element 4	B641056 Rohr 63.5x4x310	2448 S355J2G3	a 22.01.03	1,80	1,00 Stk
2	pipe 2, Element 4	B641057 Rohr 63.5x4x339	2448 S355J2G3	a 22.01.03	2,00	1,00 Stk
4	pipe 4, Element 4	B641059 Rohr 63.5x5x180	2448 S355J2G3	a 12.01.04	1,10	1,00 Stk
5	pipe 5, Element 4	B641060 Rohr 63.5x5x280	2448 S355J2G3		2,00	2,00 Stk
6	flexible hose support cpl own parts list	B641061				2,00 Stk
8	pipe holder cpl. own parts list	WAI107108				2,00 Stk
9	pipe holder cpl. own parts list	WAI107109				2,00 Stk
10	conical spring washer 12 mm	WAI102877				6,00 Stk
11	hex. nut M12 DIN 985 8. VERZ.	WAI101626				10,00 Stk
12	alien bolt M 8x75 DIN 912 8.8	WAI107115				2,00 Stk
13	spring washer A8 DIN 127 VERZ.	WAI102205			0,00	2,00 Stk
14	hex. nut M8 DIN 934 8. VERZ.	WAI102880				2,00 Stk
15	boom arm 4 processing cpl. own parts list	B671401		b 06.05.03	220,00	1,00 Stk

Drehkopf kpl.  
rotating head cpl.

B 68 1 002

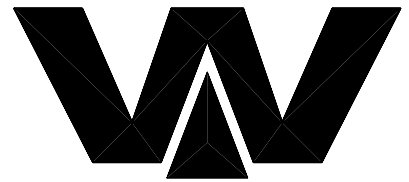

Waitzinger  
Baumaschinen GmbH

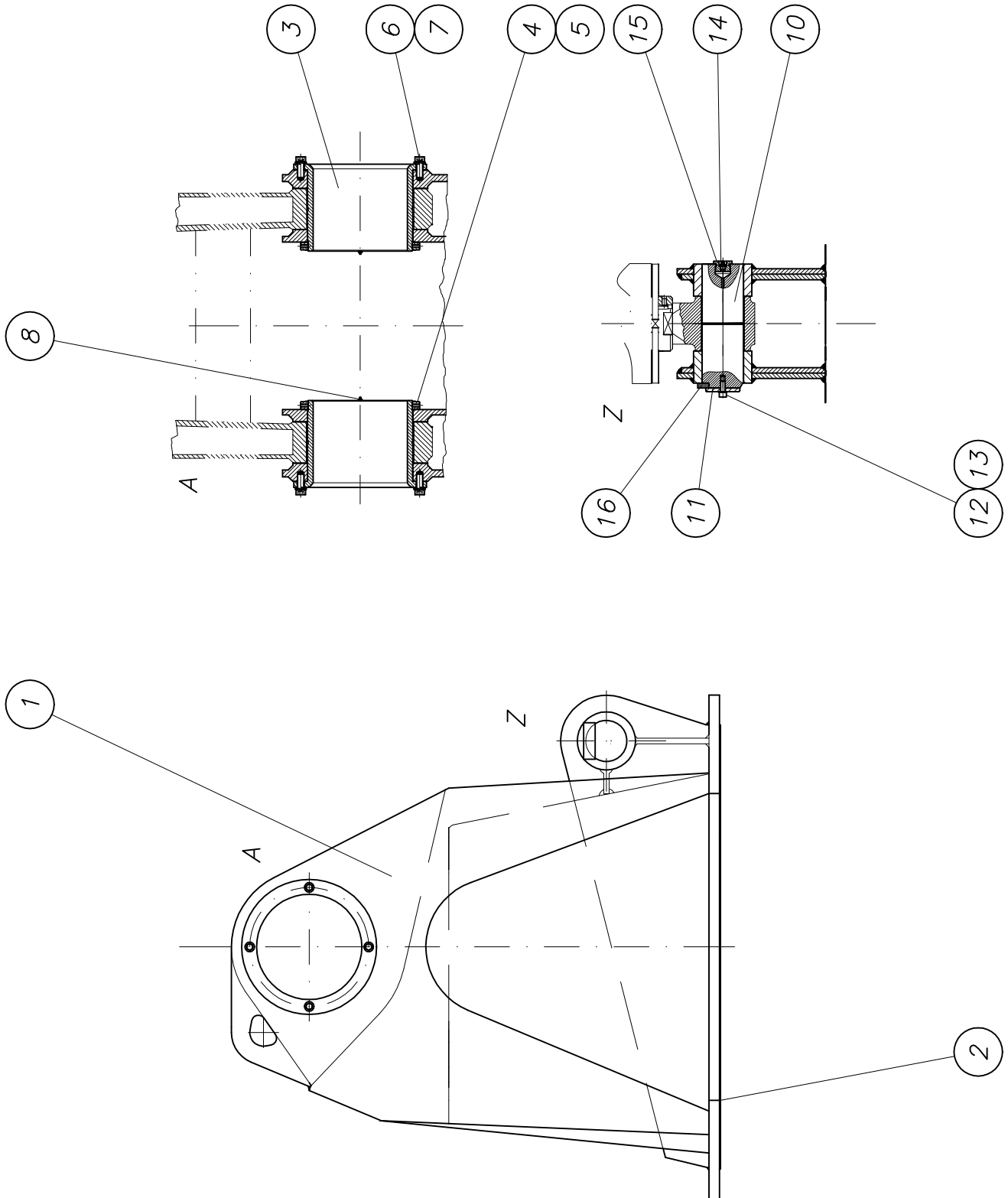



## PARTS LIST

part list	description	created	index	valid from	valid to	
B681002	rotating head unit	04.12.01 Mi				
pos	description stock	ident-no dimensions	DIN material	index	weighth Kg	quantity unit
1	rotating head unit own parts list	B681010			530,00	1,00 Stk
2	turning unit cpl. own parts list	B681045		a 09.12.04		1,00 Stk
3	pin 230x190 own parts list	B660117				2,00 Stk
4	threaded ring	WAI106624				2,00 Stk
5	set screw M 6 x 8	WAI103646				4,00 Stk
6	cheese head screw	WAI106664				8,00 Stk
7	spring washer	WAI101976			0,00	8,00 Stk
8	grease nipple	WAI102885				4,00 Stk
10	pin 90 x 271	B660114 Rd 95x275	1013 42CrMo4V	a 31.07.02	14,00	1,00 Stk
11	washer	B660087 Bl 8xd80	1543/EN10029 S235J2G3		0,20	1,00 Stk
12	cylinder head screw M 10 x 25	WAI106654				1,00 Stk
13	spring washer A10	WAI102070			0,00	1,00 Stk
14	grease nipple H1 M10 X 1 DIN 71412	WAI100805			0,01	1,00 Stk
15	locking screw M33x2 own parts list	B660085			0,10	1,00 Stk
16	pin holder	B660086 Fl 25x10x80	1017 S235J2G3		0,15	1,00 Stk



*Drehwerk Schutz kpl.*  
*turning unit safety device cpl.*

**B 68 1 045a**



Waitzinger  
Baumaschinen GmbH

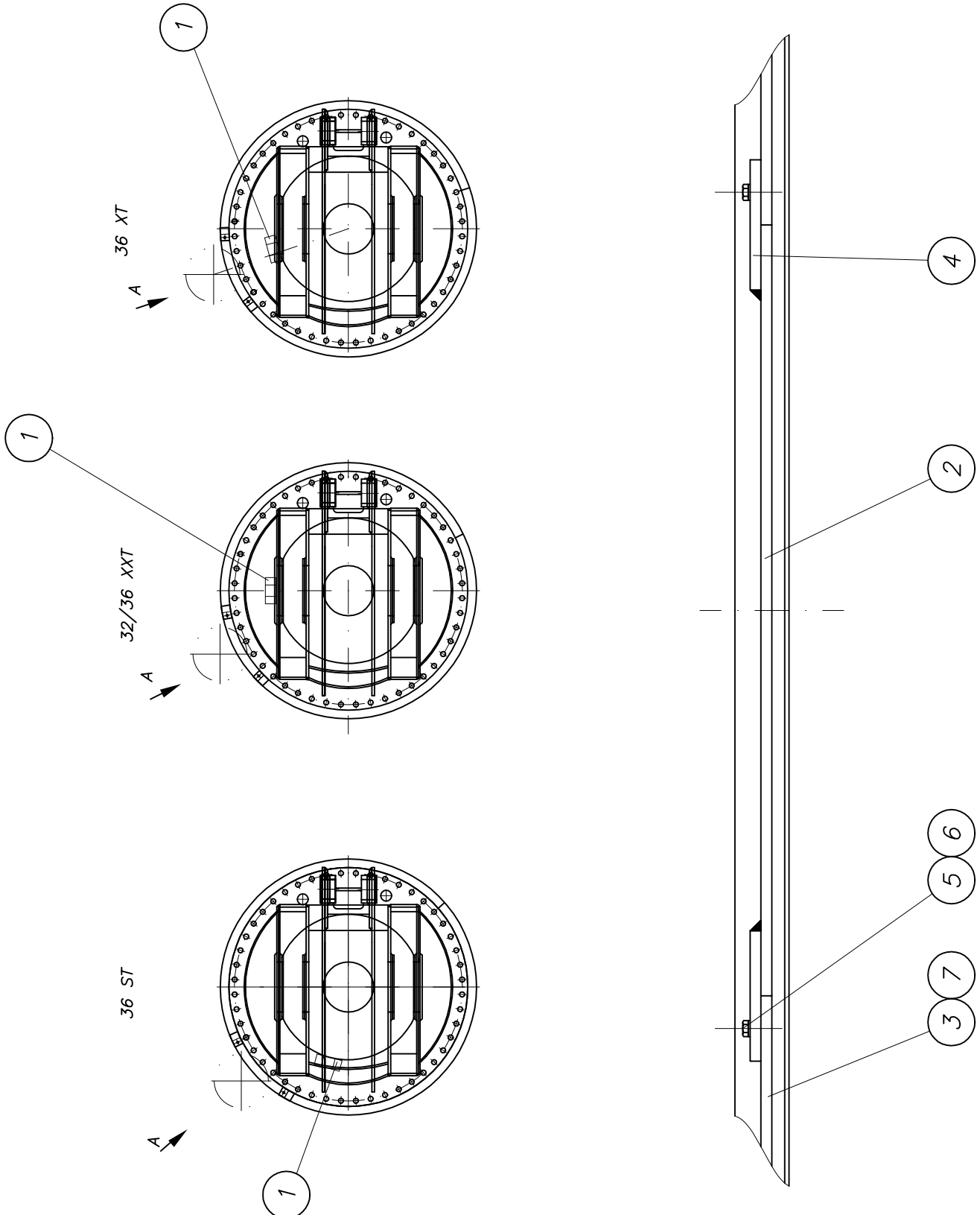



## PARTS LIST

part list	description	created	index	valid from	valid to	
B681045	turning unit cpl.	25.09.01 Mi	a	09.12.04		
pos	description stock	ident-no dimensions	DIN material	index	weighth Kg	quantity unit
1	stop	B661087 Bl 50x93x120	1543/EN10029 St52-3	a 25.02.02	3,00	1,00 Stk
2	bow	B661107 Bl 5 x 80 x 400	1543/EN10029 S355J2G3	a 25.09.01	0,40	1,00 Stk
3	bow	B661124 Bl 5 xR550xR590	1543/EN10029 S355J2G3		0,50	2,00 Stk
4	plate	B661109 Bl 5 x 60 x 40	1543/EN10029 S355J2G3		0,10	2,00 Stk
5	hexagon bolt M 8 x 12 DIN 933 8.8	WAI103274				2,00 Stk
6	spring washer A8 DIN 127 VERZ.	WAI102205			0,00	2,00 Stk
7	bow	B661123 Bl 5 xR550xR590	1543/EN10029 S355J2G3		0,50	2,00 Stk

Verrohrung Armpaket  
piping diagram arms

B 71 1 065c

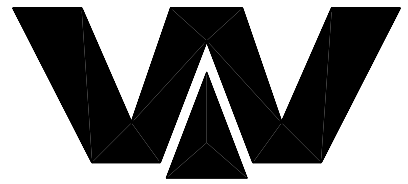

Waitzinger  
Baumaschinen GmbH

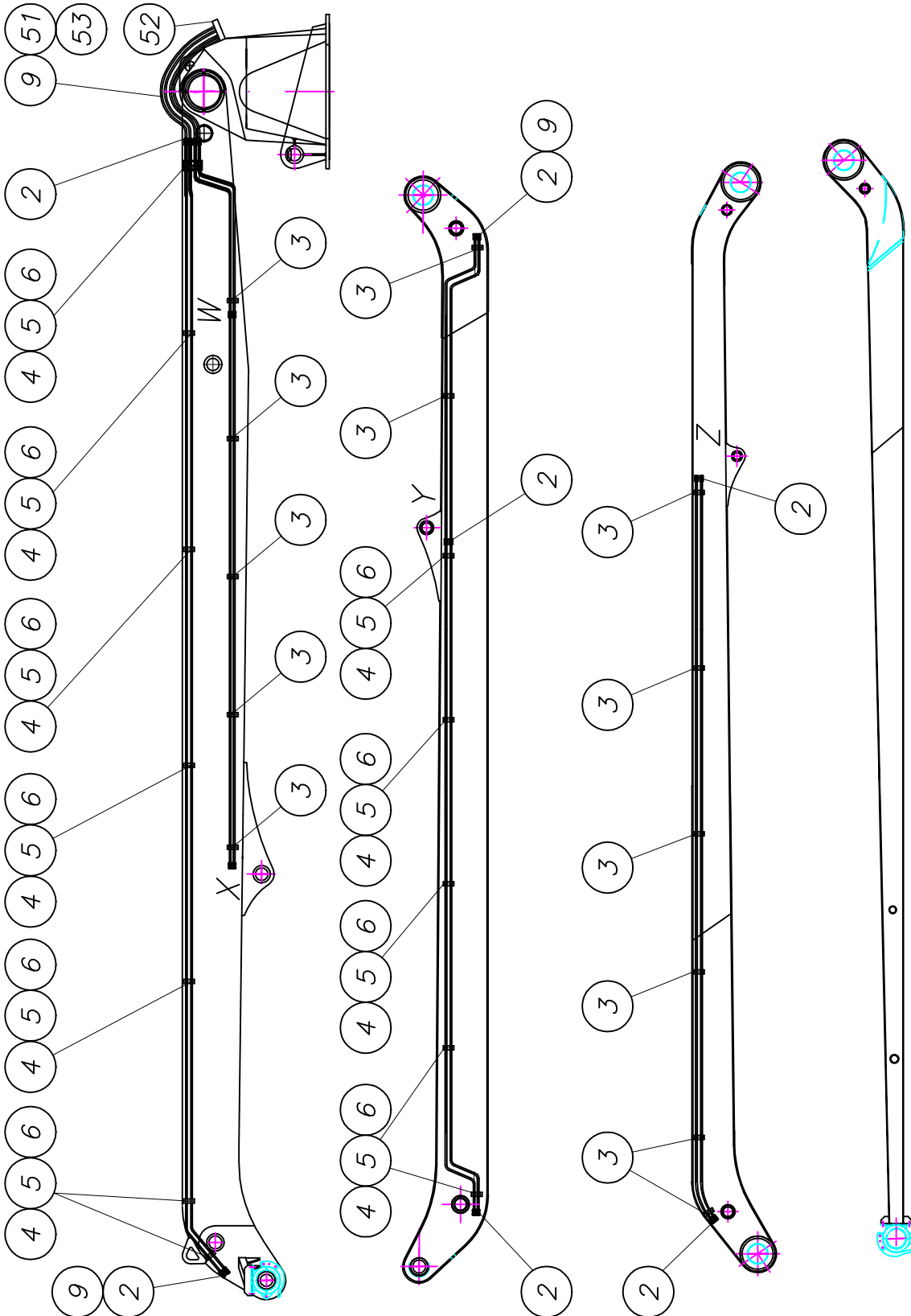



## PARTS LIST

part list	description	created	index	valid from	valid to	
B711065	pipng diagram boom	10.07.01 ek	c	02.09.03		
pos	description stock	ident-no dimensions	DIN material	index	weigth Kg	quantity unit
2	straight couplings L12	WAI100603				30,00 Stk
3	pipe clip 12 mm, own parts list	WAI105146			0,07	40,00 Stk
4	pipe clip 12mm	WAI108642				60,00 Stk
5	cover plate DP-1A	WAI108643				30,00 Stk
6	hexagon screw M 6 x 55	WAI103512				60,00 Stk
9	hydraulic hose DN10 x 1250	WAI106508				14,00 Stk
49	hydr. pipe 12 x 2	WAI102022			0,49	90,00 Mtr
51	hydraulic hose DN10 x 700	WAI101605				8,00 Stk
52	bulkhead coupling L12	WAI101384				9,00 Stk
53	Pvc Hose 100mm, blue	WAI106517				1,00 Mtr

# Übersicht B 70 - B 79 over view B 70 - B 79

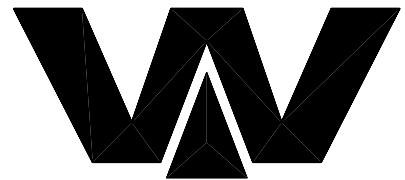

Waitzinger  
Baumaschinen GmbH

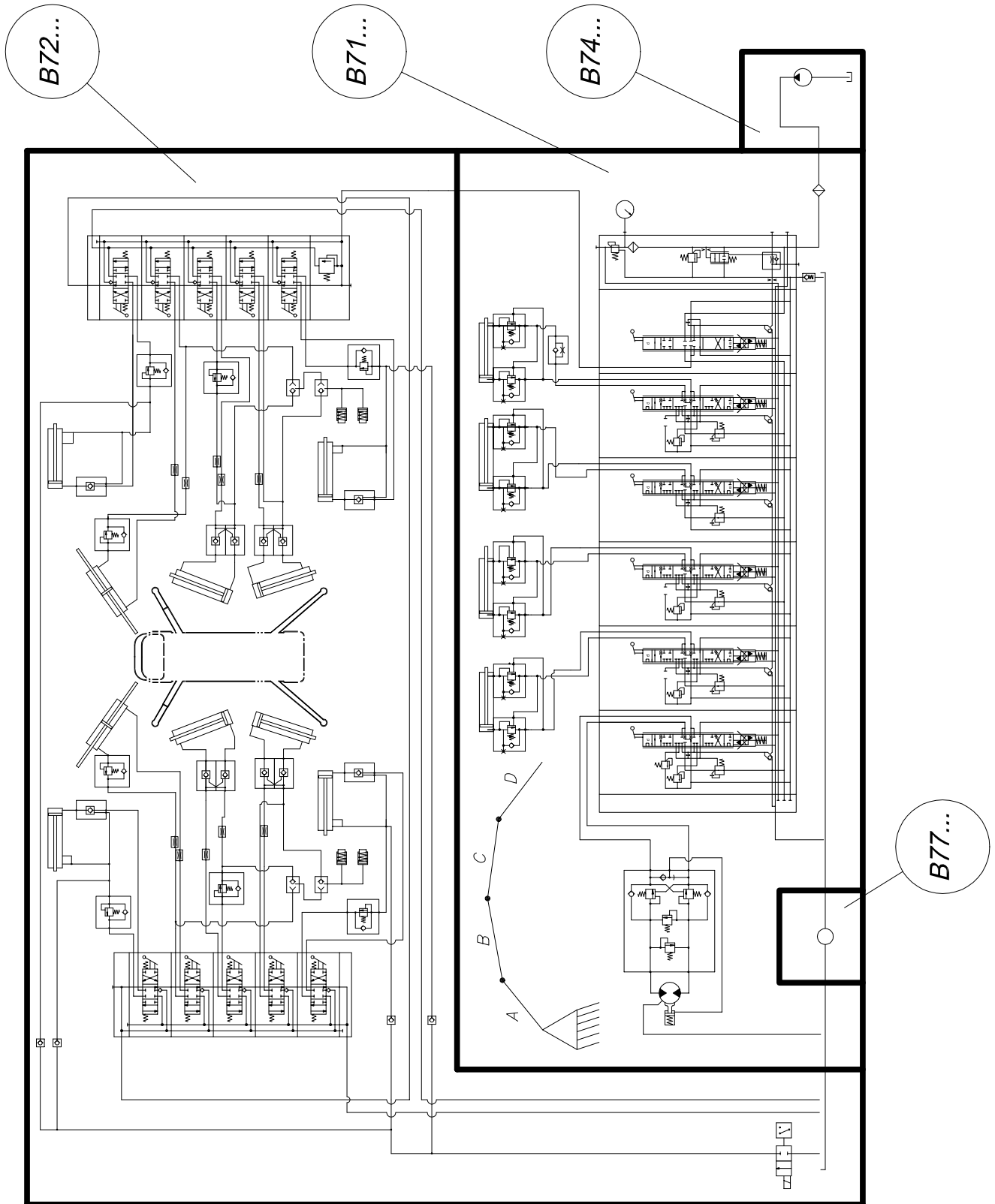

*Verrohrungsplan Pumpeinheit*  
*diagram pump unit*

*B 74 1 045a*

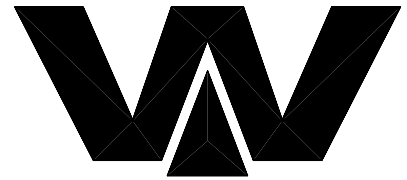

*Waitzinger*  
*Baumaschinen GmbH*

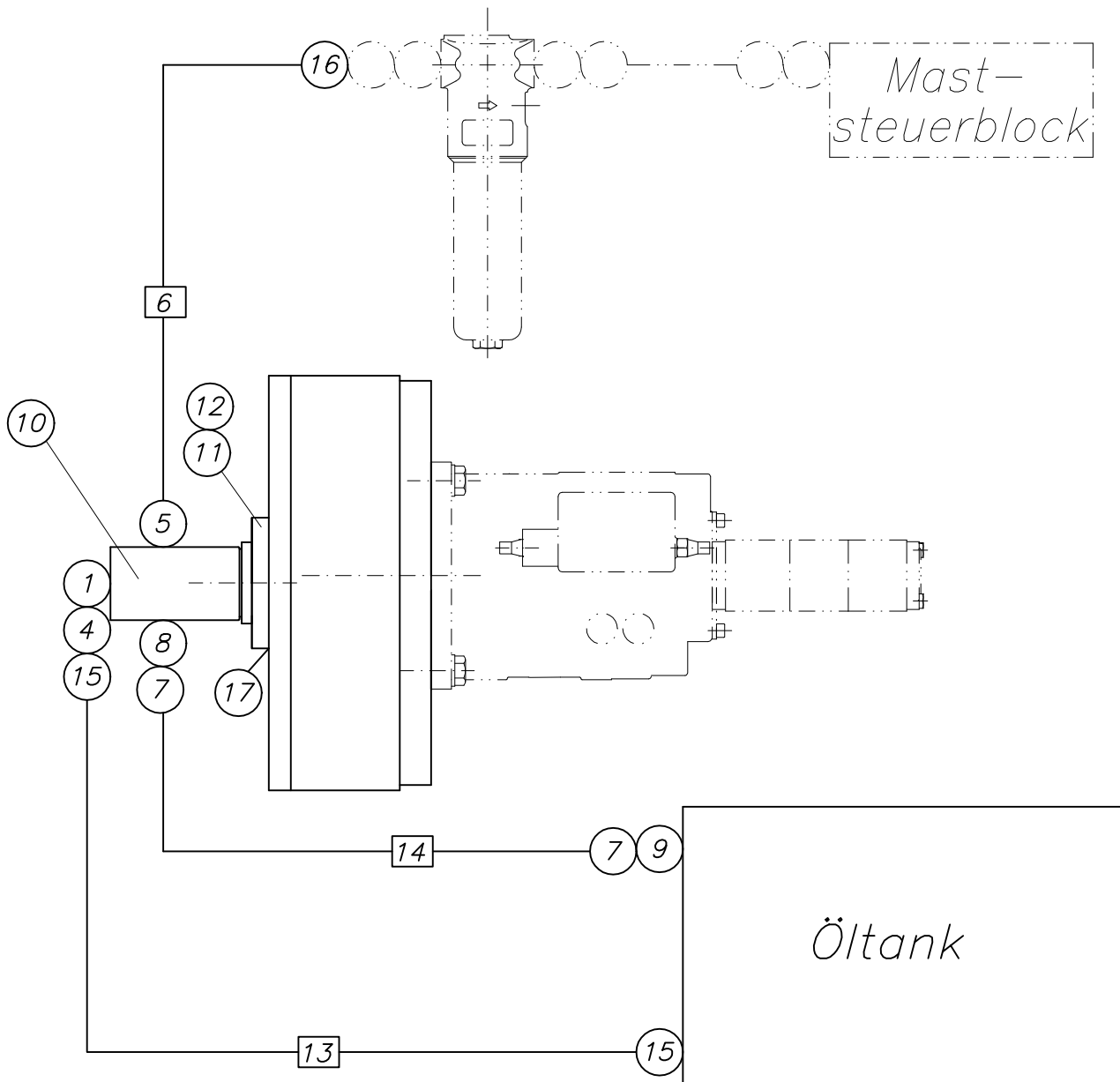



## PARTS LIST

part list	description	created	index	valid from	valid to	
B741045	pipng diagram hydraulic pump	25.07.02 Mi	a	04.08.03		
pos	description stock	ident-no dimensions	DIN material	index	weigh Kg	quantity unit
1	SAE-flange, 3/4", 3000 PSI complete	WAI104368				1,00 Stk
4	hose connection DN32, 3/4"	WAI106173				1,00 Stk
5	SAE-flange, 1/2", 6000 PSI complete	WAI105850				1,00 Stk
6	hydraulic hose DN 12 x 1500	WAI106172				1,00 Stk
7	swivel elbow L12	WAI103794				2,00 Stk
8	straight male stud couplings L12M	WAI100549				1,00 Stk
9	straight male stud couplings L12D	WAI100548				1,00 Stk
10	pump A2FO23/61 L-PAB 05	WAI103564			10,80	1,00 Stk
11	zylinder head screw M10 x 30	WAI103826				4,00 Stk
12	spring washer A10	WAI103079			0,00	4,00 Stk
13	suction hose DN 32	WAI105900				1,50 Mtr
14	hydraulic hose DN10 x 1800	WAI108350				1,00 Stk
15	hose clamp 42/20	WAI103141			0,22	2,00 Stk
16	swivel elbow S16	WAI100586				1,00 Stk
17	O-ring	WAI105771				1,00 Stk

*Übersicht B 80 - B 99*  
*over view B 80 - B 99*

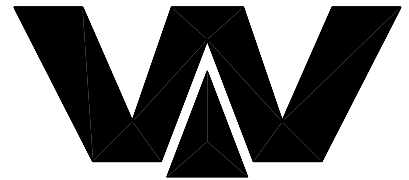

*Waitzinger  
Baumaschinen GmbH*

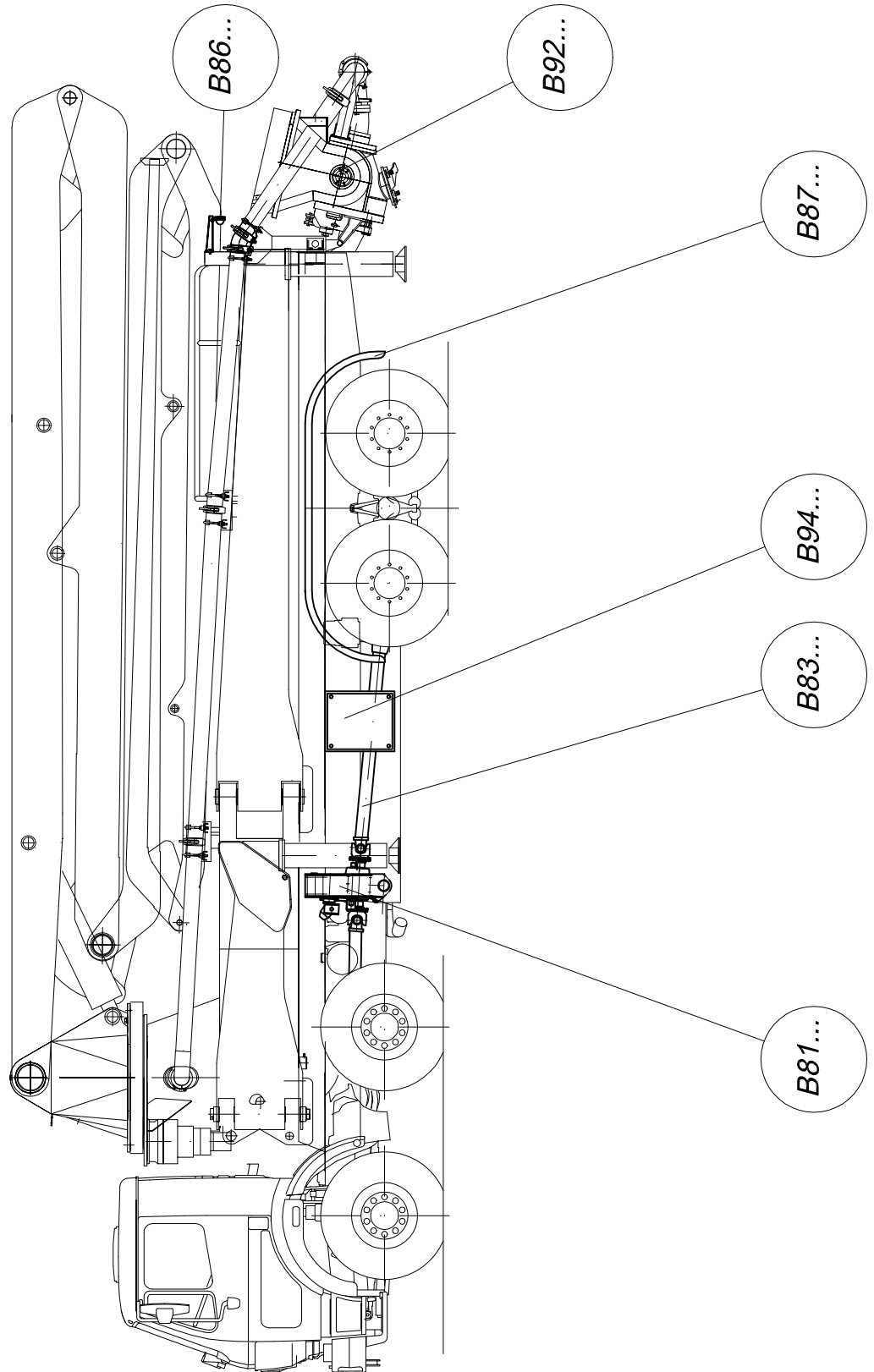



*Pneum. Getriebeumschaltung*  
*pneumatic gear change*

*B 81 4 051a*

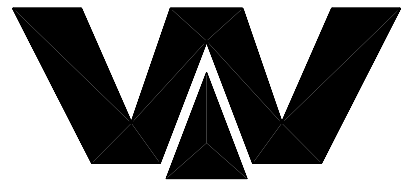

*Waitzinger*  
*Baumaschinen GmbH*

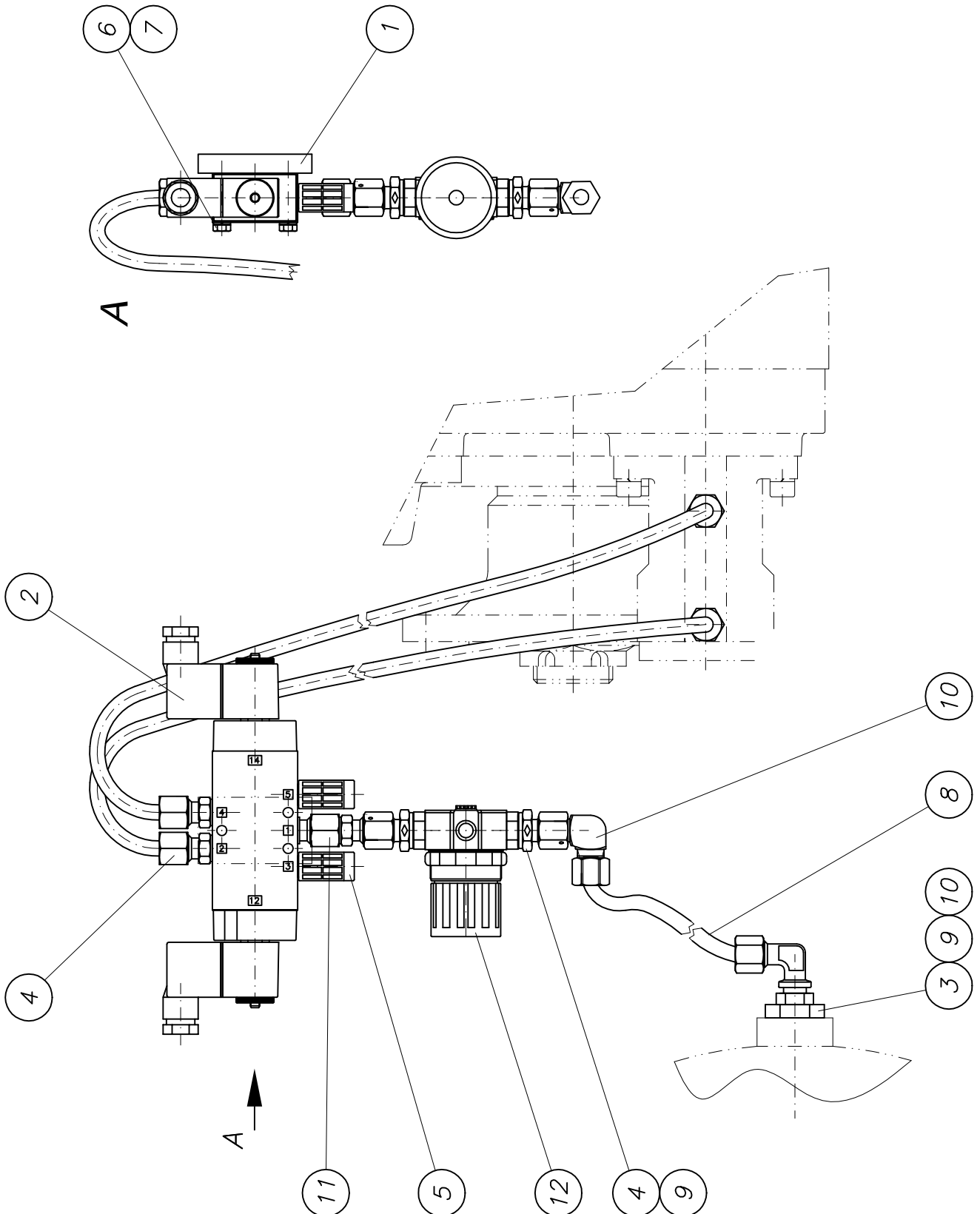



## PARTS LIST

part list	description	created	index	valid from	valid to	
B814051	pneumatic gear change	20.10.99 ek	a	25.07.00		
pos	description stock	ident-no dimensions	DIN material	index	weighth Kg	quantity unit
1	tap plate for 5/2 way valve	B814031 BI 10x35x60	1543/EN10029 St37-2		0,17	1,00 Stk
2	pneumatic 5/2-way valve, 24 V own parts list	WAI100128			0,43	1,00 Stk
3	straigt male stud coupling L8 M22x1.5	WAI106295			0,11	1,00 Stk
4	male stud couplings L8 R 1/8"	WAI103497				7,00 Stk
5	silencer	WAI103526			0,00	2,00 Stk
6	hexagon bolt M 5 x 35	WAI104119				3,00 Stk
7	spring washer	WAI102246				3,00 Stk
8	plastic pipe	WAI100871			0,50	6,50 mtr
9	strengthening sleeve	WAI103493				10,00 Stk
10	adjustable elbow bodies L8	WAI100589				3,00 Stk
11	non return valve	WAI105882				1,00 Stk
12	pressure reducing valve	WAI105881				1,00 Stk
13	straight coupling SNV 8L	WAI101938				1,00 Stk
14	adjustable elbow bodies L8	WAI100589				1,00 Stk

*Verteilergetriebe kpl.*  
*gear box cpl.*

**B 81 4 086**

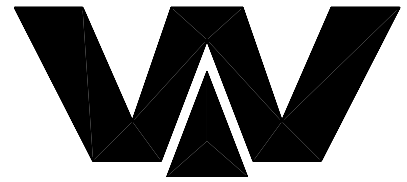

Waitzinger  
Baumaschinen GmbH

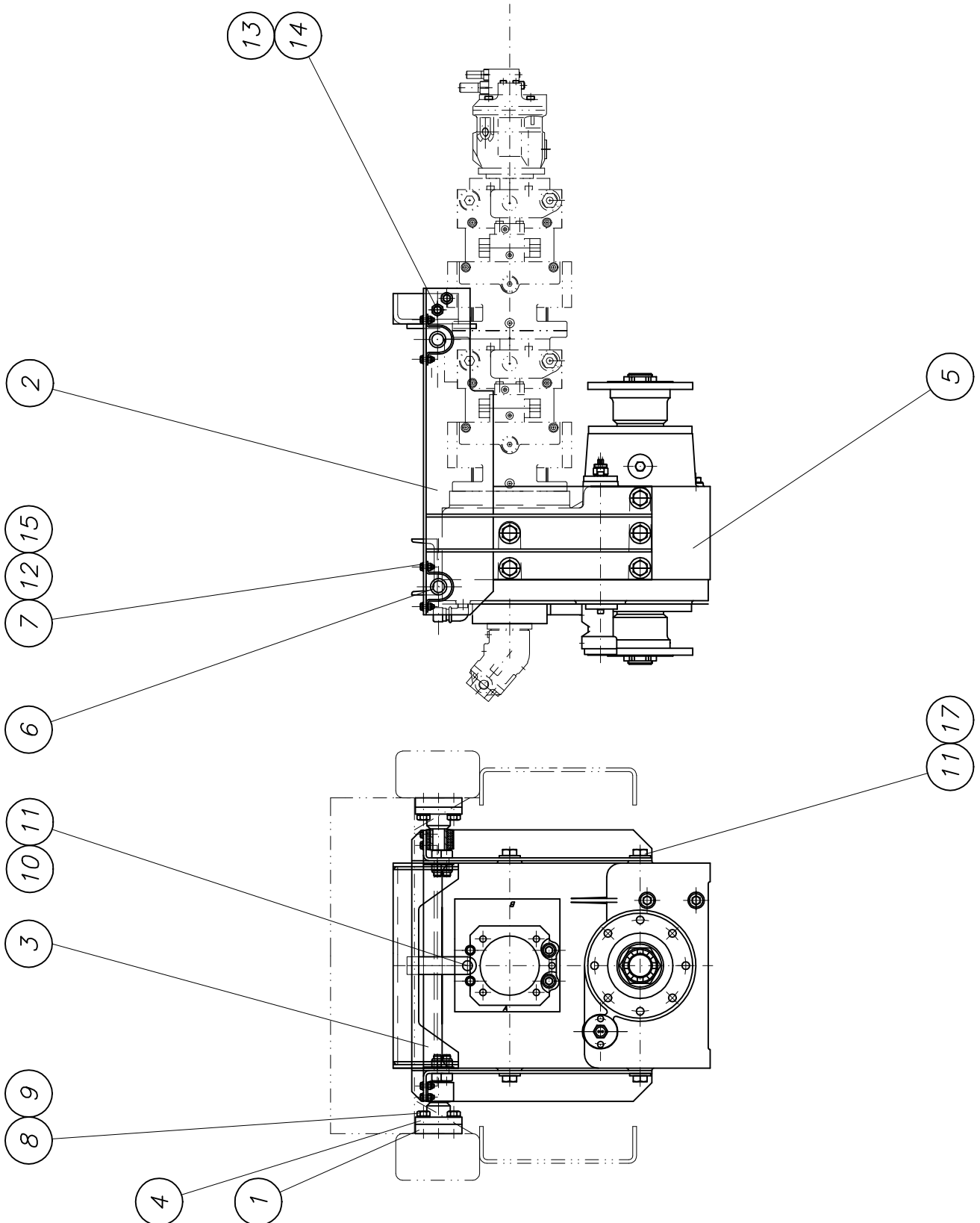



## PARTS LIST

part list	description	created	index	valid from	valid to	
B814086	distributor gear box 4496.xx	14.08.03 ek				
pos	description stock	ident-no dimensions	DIN material	index	weigh Kg	quantity unit
1	axle own parts list	B813133			1,50	4,00 Stk
2	console own parts list	B813121		a 07.04.03		1,00 Stk
3	cross profile own parts list	B813124		b 03.03.03	4,50	1,00 Stk
4	thread plate	B813104 FI 100x20x100	174 St37-2		1,50	4,00 Stk
5	PTO gearbox 4496. own parts list	WAI108412				1,00 Stk
6	buffer	WAI103414				4,00 Stk
7	hexagon bolt M8 x 25 DIN 933 8.8	WAI101621				16,00 Stk
8	hexagon bolt M16 x 35	WAI102071			0,08	16,00 Stk
9	conical spring washer	WAI100506				16,00 Stk
10	bracket	B813128 Bl 10x38x149	1543/EN10029 S235J2G3		0,40	1,00 Stk
11	hexagon bolt M 20 x 50	WAI102860				11,00 Stk
12	stop nut M8 DIN985 8. VERZ.	WAI102111			5,00	16,00 Stk
13	cheese head screw M 16 x 40	WAI102859				4,00 Stk
14	nut M16 DIN 985	WAI102330				4,00 Stk
15	washer 8.4	WAI101625				16,00 Stk
17	conical spring washer	WAI102110			0,05	10,00 Stk

*Arbeitsscheinwerfer kpl.*  
*head lamp cpl.*

*B 86 4 011*

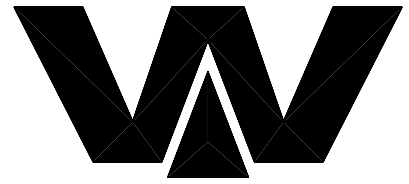

*Waitzinger*  
*Baumaschinen GmbH*

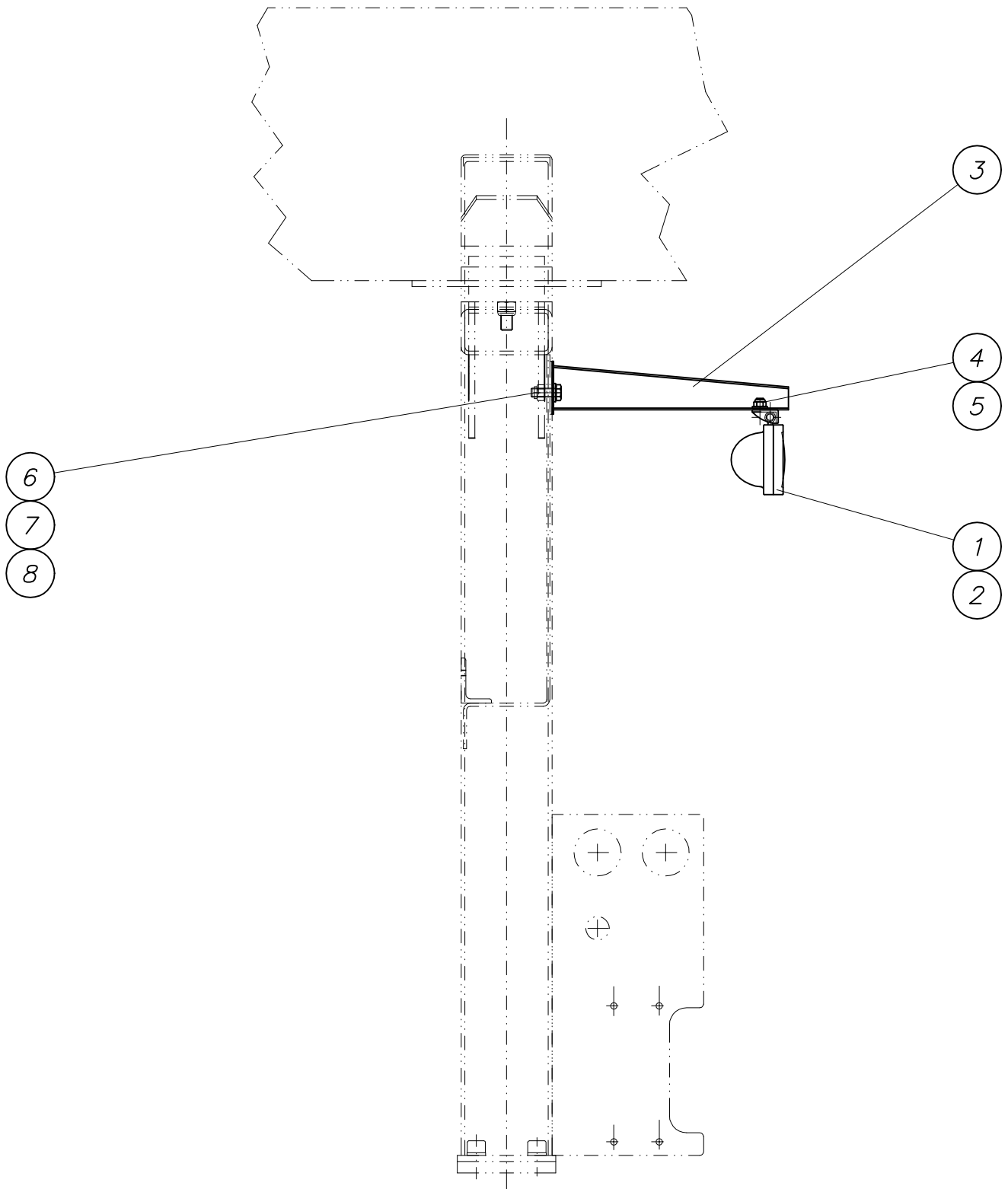



# PARTS LIST

part list	description	created	index	valid from	valid to	
B864011	mounting for lamp	31.01.00 Mi				
pos	description stock	ident-no dimensions	DIN material	index	weigh Kg	quantity unit
1	lamp	WAI105322				1,00 Stk
2	lamp 24V	WAI105989				1,00 Stk
3	bracket	WAI106009				1,00 Stk
4	hex. nut M10 DIN985 8.	WAI102125			0,01	1,00 Stk
5	washer 10.5	WAI101559			0,00	1,00 Stk
6	hex. bolt M12 x 25 DIN 933 8.8	WAI101001			0,04	1,00 Stk
7	hex. nut M12 DIN 985 8. VERZ.	WAI101626				1,00 Stk
8	washer	WAI102962			0,01	2,00 Stk

*Halter kpl.  
outrigger pad cpl.*

*B 91 3 010c*

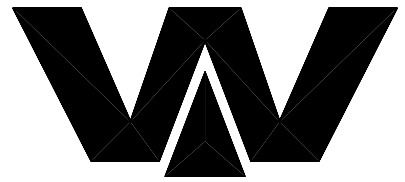

*Waitzinger  
Baumaschinen GmbH*

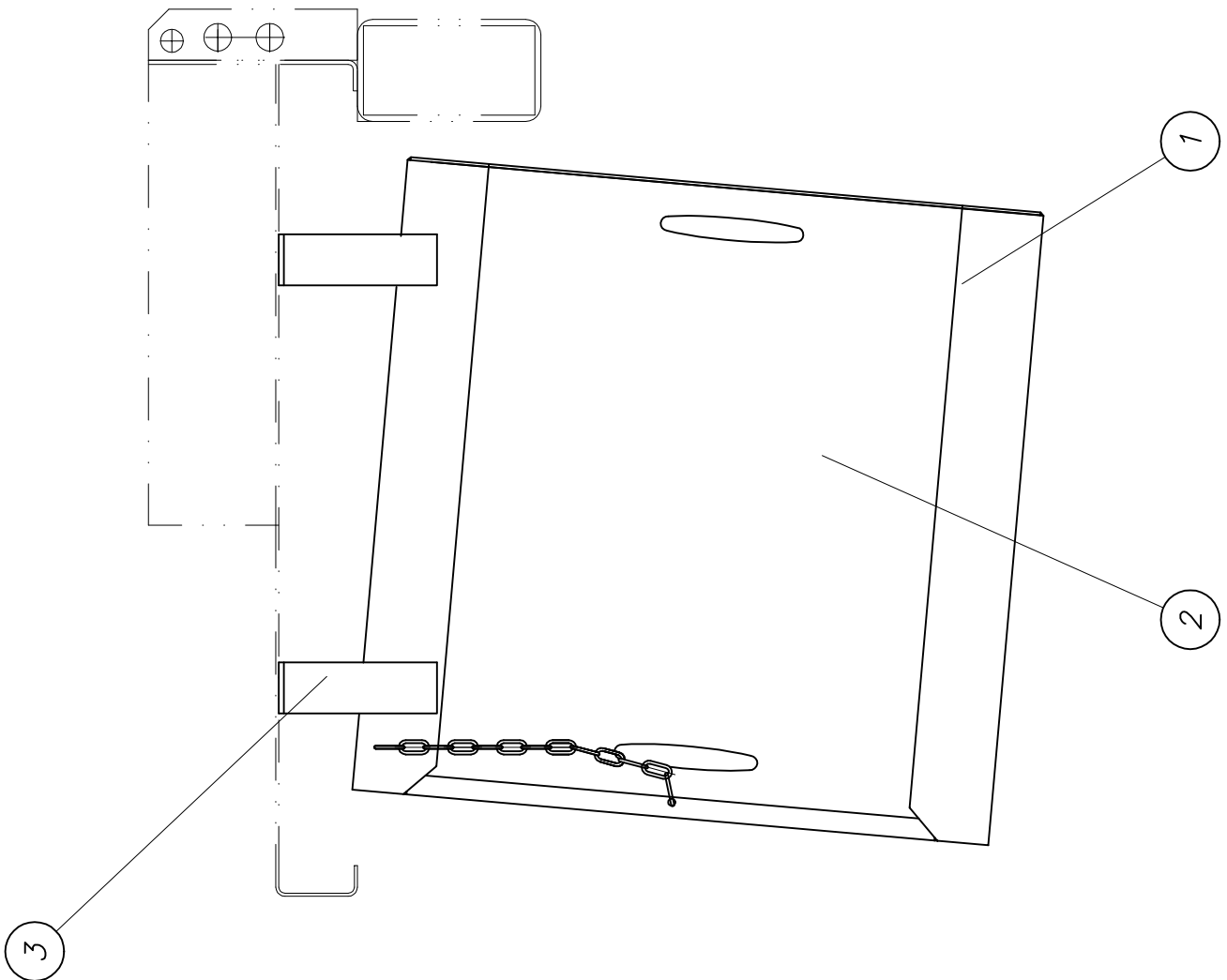
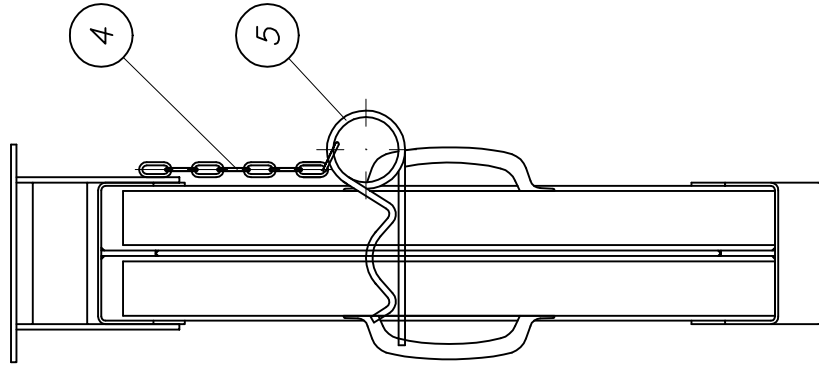



# PARTS LIST

part list	description	created	index	valid from	valid to	
B913010	holder cpl.	10.07.97 HG	c	29.04.03		
pos	description stock	ident-no dimensions	DIN material	index	weigh Kg	quantity unit
1	holder own parts list	B913011		a 26.05.03	14,50	2,00 Stk
2	pad 600 x 600 x 40	WAI107152				4,00 Stk
3	bracket own parts list	B913018			1,24	4,00 Stk
4	chain segment	WAI103329				30,00 Stk
5	cotter pin	WAI101266			0,06	2,00 Stk



*Schildersatz Betonpumpe  
sticker set concrete pump*

*B 92 1 004*

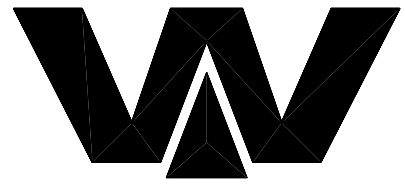

*Waitzinger  
Baumaschinen GmbH*

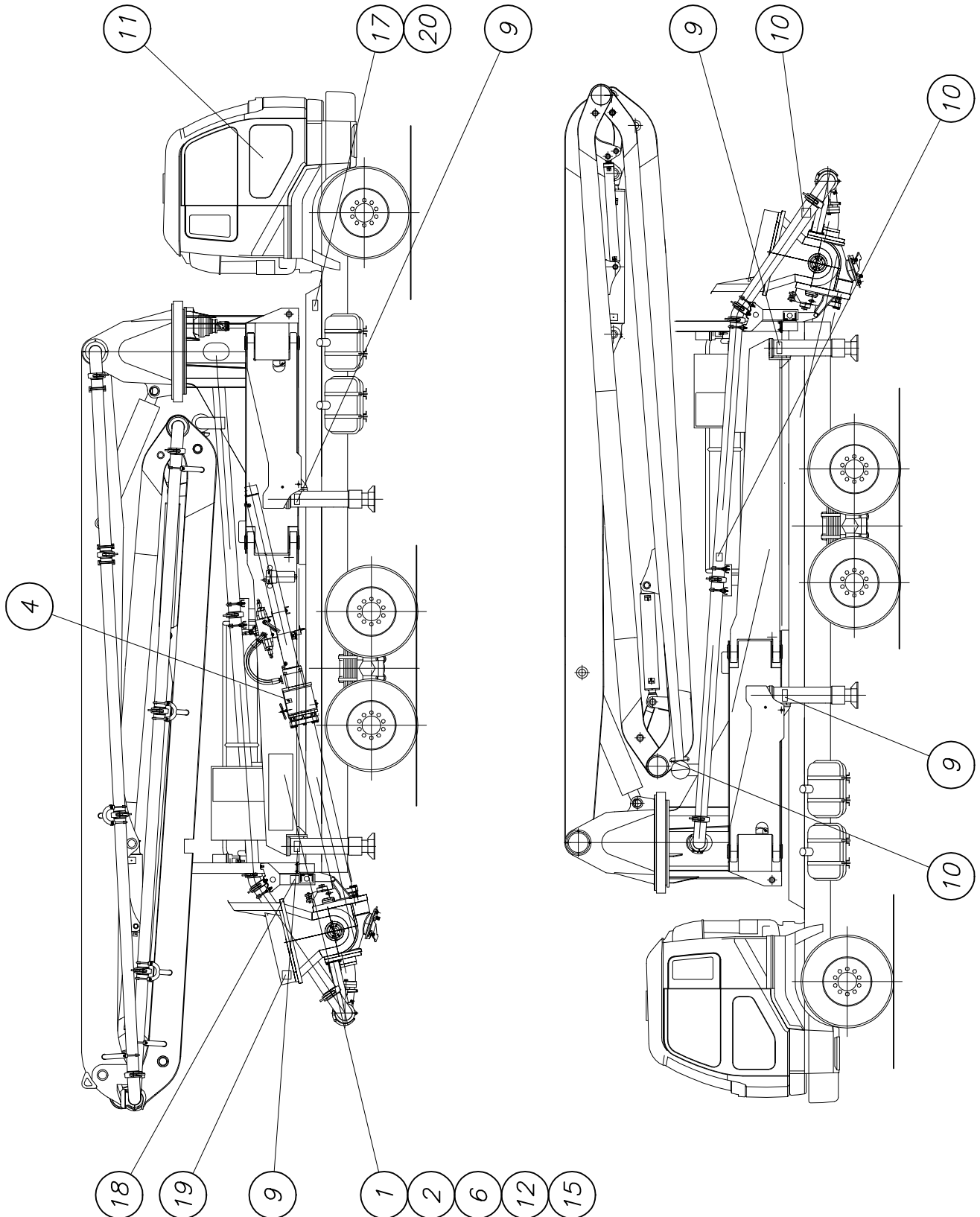



## PARTS LIST

part list	description	created	index	valid from	valid to	
B921004	sticker set CP english without boom	21.09.00 hbk				
pos	description stock	ident-no dimensions	DIN material	index	weighth Kg	quantity unit
1	sticker operation eng.	WAI105932				1,00 Stk
2	sticker electrocution hazard d/e	WAI105934				1,00 Stk
4	sticker danger of bruise d/e	WAI105936				1,00 Stk
6	sticker remote control d/e	WAI105938				1,00 Stk
7	sticker hopper d/e	WAI105939				1,00 Stk
9	sticker outrigger d/e	WAI105941				4,00 Stk
10	sticker coupling d/e	WAI105942				3,00 Stk
11	sticker gearbox switch system d/e	WAI105943				1,00 Stk
12	sticker person protection d/e	WAI105944				1,00 Stk
15	sticker electrocution hazard 2 d/e	WAI105974				1,00 Stk
17	identification badge	WAI106179				1,00 Stk
18	sign AL agitator	WAI106030				1,00 Stk
19	sign AL water pump	WAI106031				1,00 Stk
20	sign AL delivery line	WAI106032				1,00 Stk



# PARTS LIST

part list	description	created	index	valid from	valid to	
B610050	sticker set pesdestal 36 XT	20.09.00 hbk				
pos	description stock	ident-no dimensions	DIN material	index	weigh Kg	quantity unit
1	sign plate for outrigger 36XT left	WAI106347				1,00 Stk
2	sign plate for outrigger 36XT right	WAI106346				1,00 Stk
3	sign plate for boom	WAI106345				1,00 Stk
4	sticker danger of bruise	WAI106367				2,00 Stk
5	sign AL jackcylinder	WAI106365				4,00 Stk
6	sticker check stabilzers	WAI106370				1,00 Stk
7	sticker grease nipple	WAI106369				1,00 Stk
8	sticker outrigger d/e	WAI105941				2,00 Stk
9	sticker sloping 3 degrees	WAI106366				2,00 Stk
10	sticker Al Reach of 36 XT own parts list	WAI106373				1,00 Stk

*Schildersatz Mast  
sticker set boom*

*B 66 0 051*

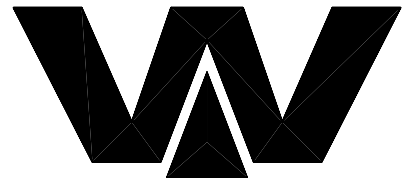

*Waitzinger  
Baumaschinen GmbH*

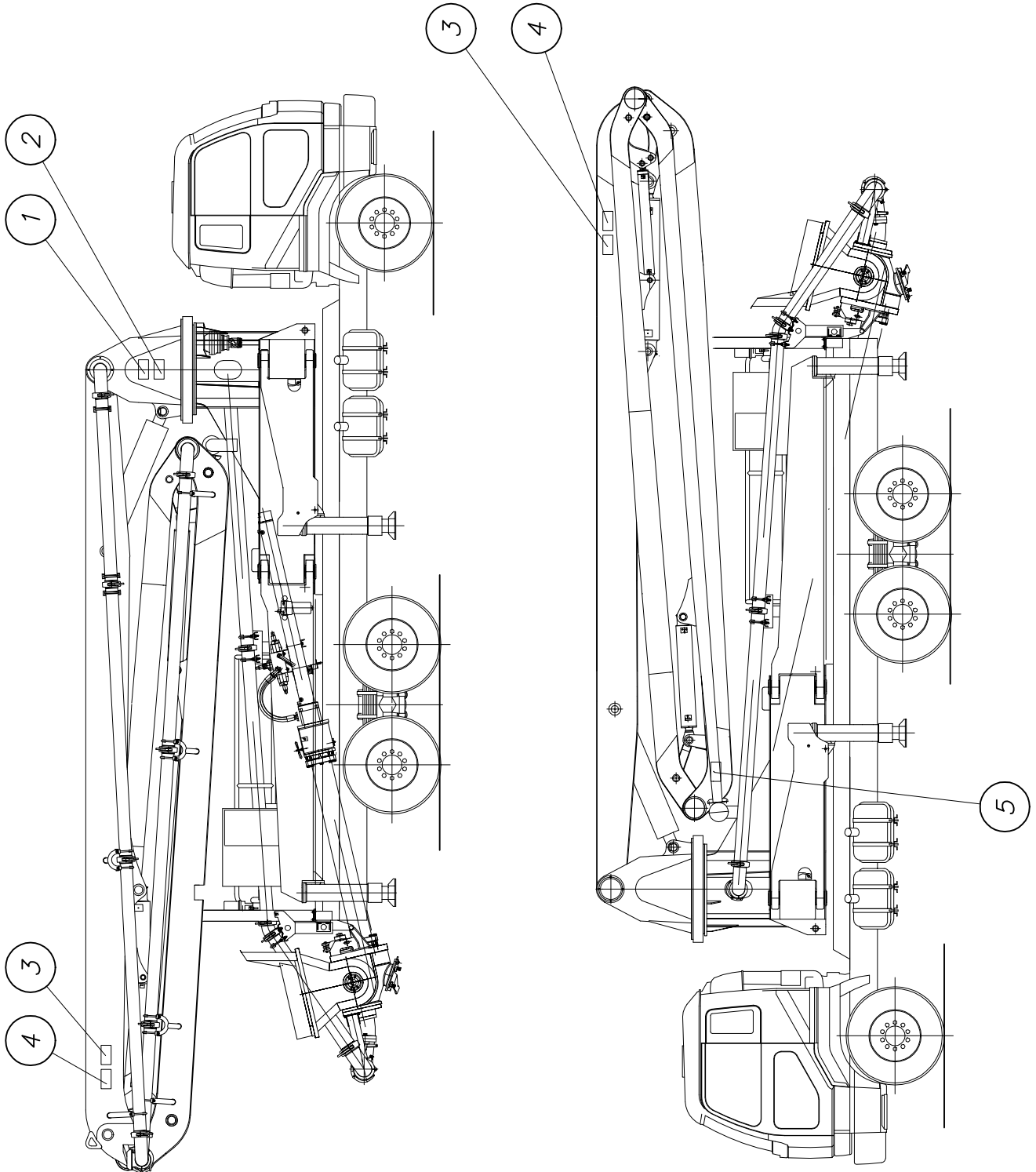



## PARTS LIST

<b>part list</b>	<b>description</b>	<b>created</b>	<b>index</b>	<b>valid from</b>	<b>valid to</b>	
B660051	sticker boom 36 ST	21.09.00 hbk				
<b>pos</b>	<b>description stock</b>	<b>ident-no dimensions</b>	<b>DIN material</b>	<b>index</b>	<b>weigh Kg</b>	<b>quantity unit</b>
1	sticker AI Reach of 36 ST	WAI106378				1,00 Stk
2	sticker electrocution hazard d/e	WAI105934				1,00 Stk
3	sticker crane d/e	WAI105937				2,00 Stk
4	sticker danger area d/e	WAI105940				2,00 Stk
5	sticker weight endhose d/e	WAI105975				2,00 Stk

Werkzeugkasten kpl.

tool box cpl.

B 94 1 020d

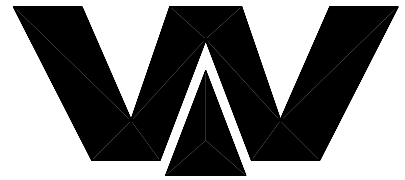

Waitzinger  
Baumaschinen GmbH

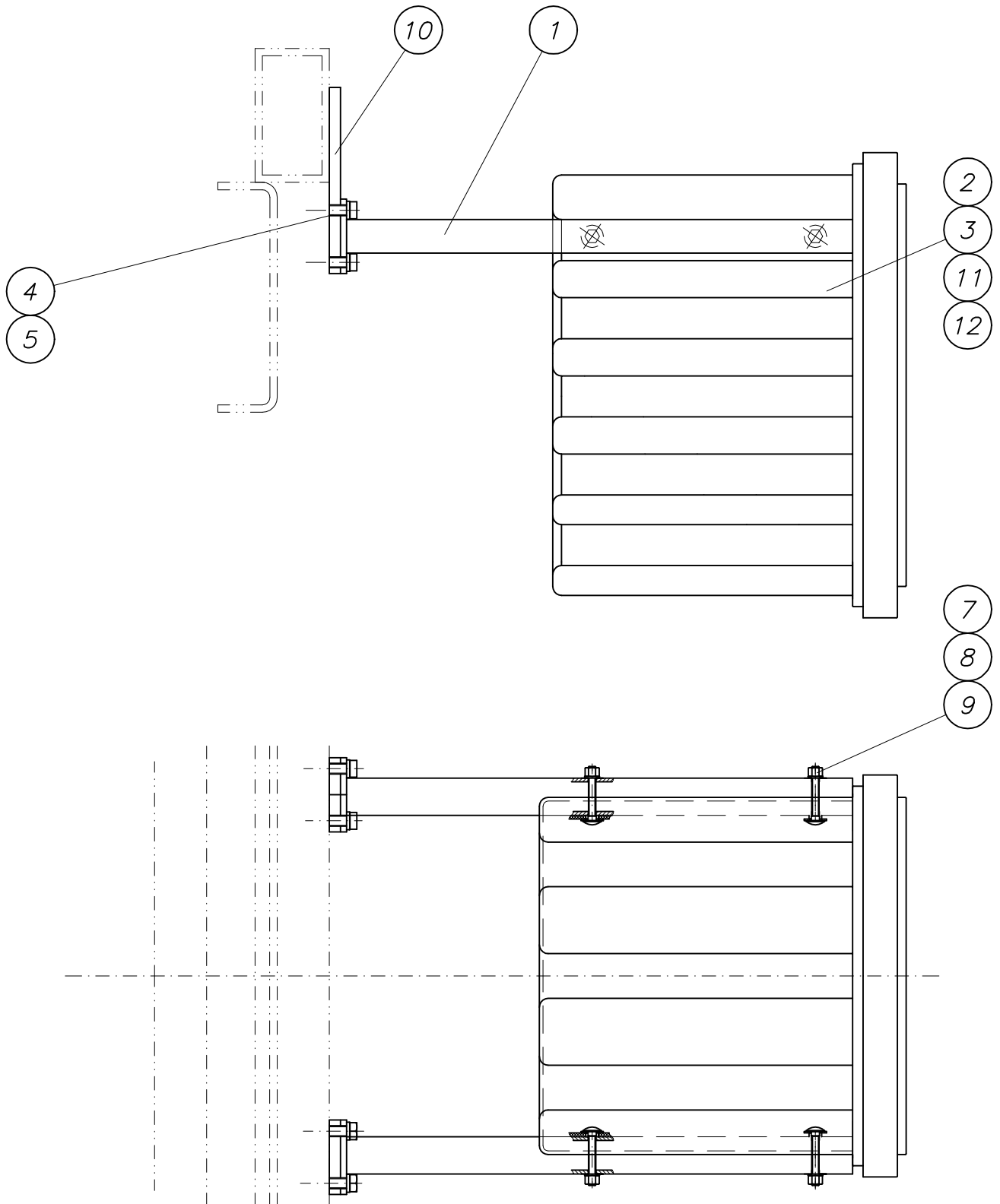



## PARTS LIST

part list	description	created	index	valid from	valid to	
B941020	tool box with holder cpl.	14.03.00 ek	d	21.02.05		
pos	description stock	ident-no dimensions	DIN material	index	weighth Kg	quantity unit
1	bracket for tool box own parts list	B941022		a 27.07.04	3,60	2,00 Stk
2	toolbox	WAI105898				1,00 Stk
3	tool set for concrete pump own parts list	WAI105912				1,00 Stk
4	cheese head screw	WAI106664				8,00 Stk
5	spring washer	WAI103668			0,00	8,00 Stk
7	cup square neck bolt M 10 x 70	WAI106042 M10x70	603 8.8			4,00 Stk
8	washer 10.5	WAI101559			0,00	4,00 Stk
9	hex. nut M10 DIN985 8.	WAI102125			0,01	4,00 Stk
10	plate	B941026 Bl 15x100x250	EN 10029 S235J2G3	a 26.02.04	3,20	2,00 Stk
11	accessories for toolbox	wai109370				1,00 Stk
12	accessories for toolbox	wai109371				1,00 Stk

# **REED SCHEMATIC LIST-MODEL XT36-160**

## **CONCRETE BOOM PUMP**

### **CUSTOMER INFO:**

**REED**

**MODEL: XT36-160 CONCRETE BOOM PUMP**

**REED-SN 06-249**

**BOOM-SN:**

### **SCHEMATICS LIST**

<b>PART No.</b>	<b>DESCRIPTION</b>
<b>B 51 3 022</b>	<b>WIRING DIAGRAM (4 SHEETS)</b>
<b>B 51 3 027</b>	<b>WIRING DIAGRAM-OPTION</b>
<b>B 56 2 048</b>	<b>CABLE LOOP (2 SHEETS)</b>
<b>B 56 2 050</b>	<b>CABLE HARNESS</b>
<b>B 56 2 063</b>	<b>CABLE LOOP-PUMP (4 SHEETS)</b>
<b>B 40 4 010</b>	<b>HYDRAULIC SYSTEM</b>
<b>B 71 8 001</b>	<b>HYDRAULIC SYSTEM</b>
<b>B 71 8 002</b>	<b>HYDRAULIC SYSTEM</b>
<b>B 72 8 015</b>	<b>HYDRAULIC SYSTEM (3 SHEETS)</b>









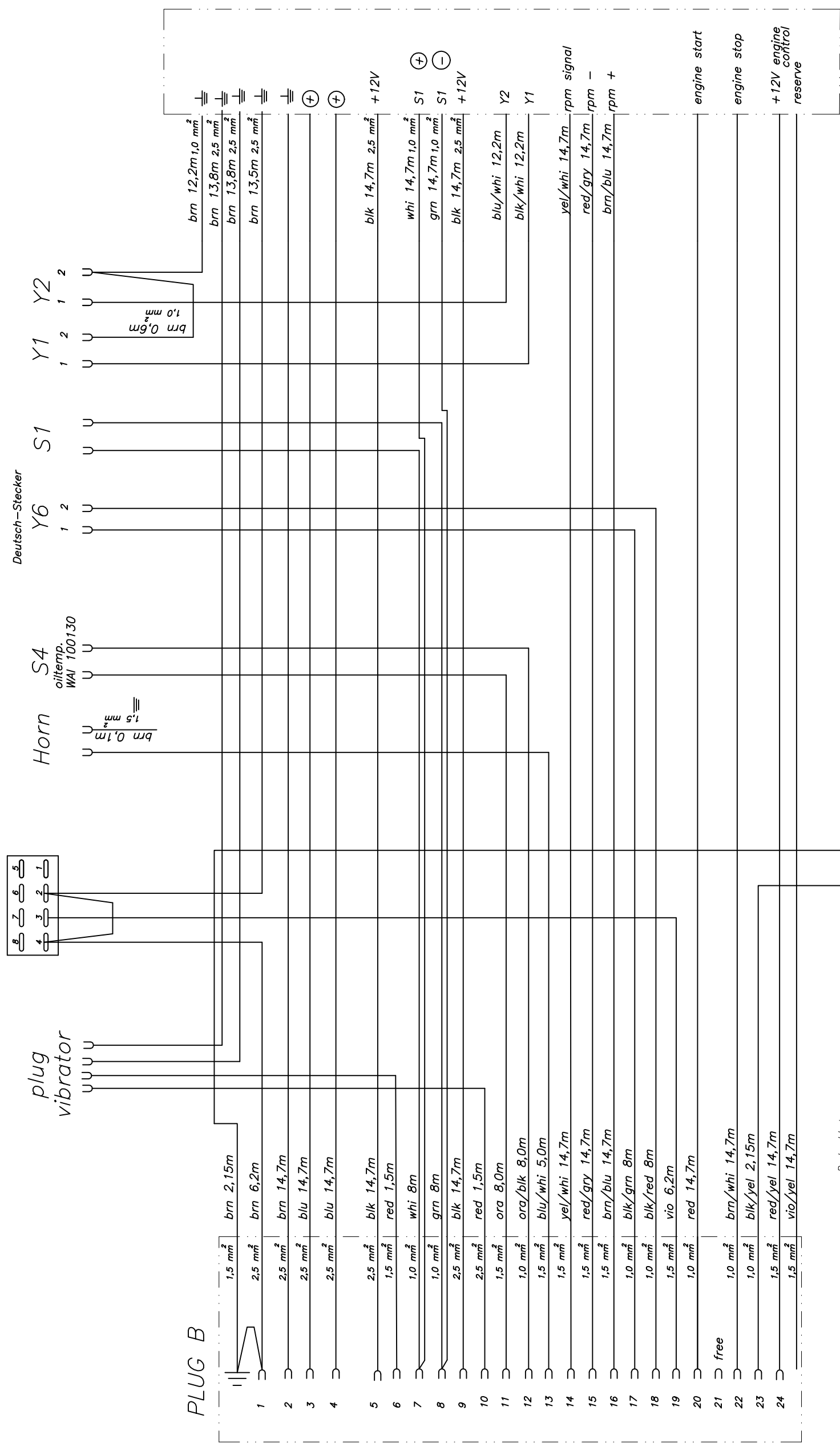
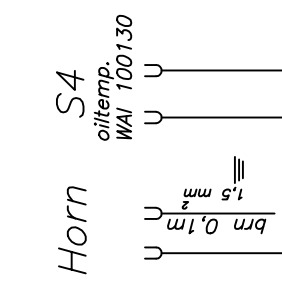
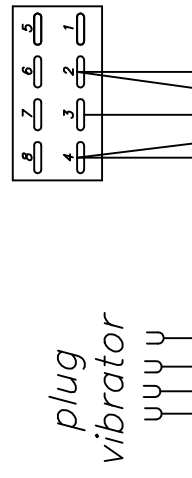

PLUG B

- 1 1,5 mm<sup>2</sup> brn 2,15m
- 2 2,5 mm<sup>2</sup> brn 6,2m
- 3 2,5 mm<sup>2</sup> brn 14,7m
- 4 2,5 mm<sup>2</sup> blu 14,7m
- 5 2,5 mm<sup>2</sup> blu 14,7m
- 6 2,5 mm<sup>2</sup> blk 14,7m
- 7 1,5 mm<sup>2</sup> red 1,5m
- 8 1,0 mm<sup>2</sup> whi 8m
- 9 1,0 mm<sup>2</sup> grn 8m
- 10 2,5 mm<sup>2</sup> blk 14,7m
- 11 2,5 mm<sup>2</sup> red 1,5m
- 12 1,5 mm<sup>2</sup> ora 8,0m
- 13 1,0 mm<sup>2</sup> ora/blk 8,0m
- 14 1,5 mm<sup>2</sup> blu/whi 5,0m
- 15 1,5 mm<sup>2</sup> yel/whi 14,7m
- 16 1,5 mm<sup>2</sup> red/ggy 14,7m
- 17 1,5 mm<sup>2</sup> brn/blu 14,7m
- 18 1,0 mm<sup>2</sup> blk/grn 8m
- 19 1,0 mm<sup>2</sup> blk/red 8m
- 20 1,5 mm<sup>2</sup> vio 6,2m
- 21 1,0 mm<sup>2</sup> red 14,7m
- 22 free
- 23 1,0 mm<sup>2</sup> brn/whi 14,7m
- 24 1,0 mm<sup>2</sup> blk/yel 2,15m
- 25 1,5 mm<sup>2</sup> red/yel 14,7m
- 26 1,5 mm<sup>2</sup> vio/yel 14,7m

Längen alle genaues Maß --> Zugabe ca. 1m

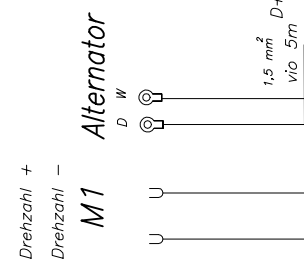

Option :  
z.B. Göker



Waitzinger  
Baumaschinen  
Vertrieb und  
Service GmbH

FREE DIMENSION  
TOLERANCE  
DIN 7168  
MEDIUM

SCALE without

WEIGHT  
own parts list

NAME	Körner
DATE	08.04.2004
DRAWN	
CHKD.	
APPD.	

ISSUE	MODIFICATION	DATE	NAME

14	1,5 mm <sup>2</sup> yel/whi 14,7m
15	1,5 mm <sup>2</sup> blu 14,7m
16	1,5 mm <sup>2</sup> blk 14,7m

cable loop truck  
for B\_513022

CHANGE ONLY WITH CAD

ORIGINAL

REPLACEMENT FOR  
B 56 2 048

SHEET 2  
OF 2

THIS INFORMATION MAY NOT BE COPIED BY A  
THIRD PARTY. SUBJECT TO COPYRIGHT (PARA-  
GRAPH 1 NO. 3 OF "URHEBERRECHTSGESETZ"  
FROM 14.06.1991)

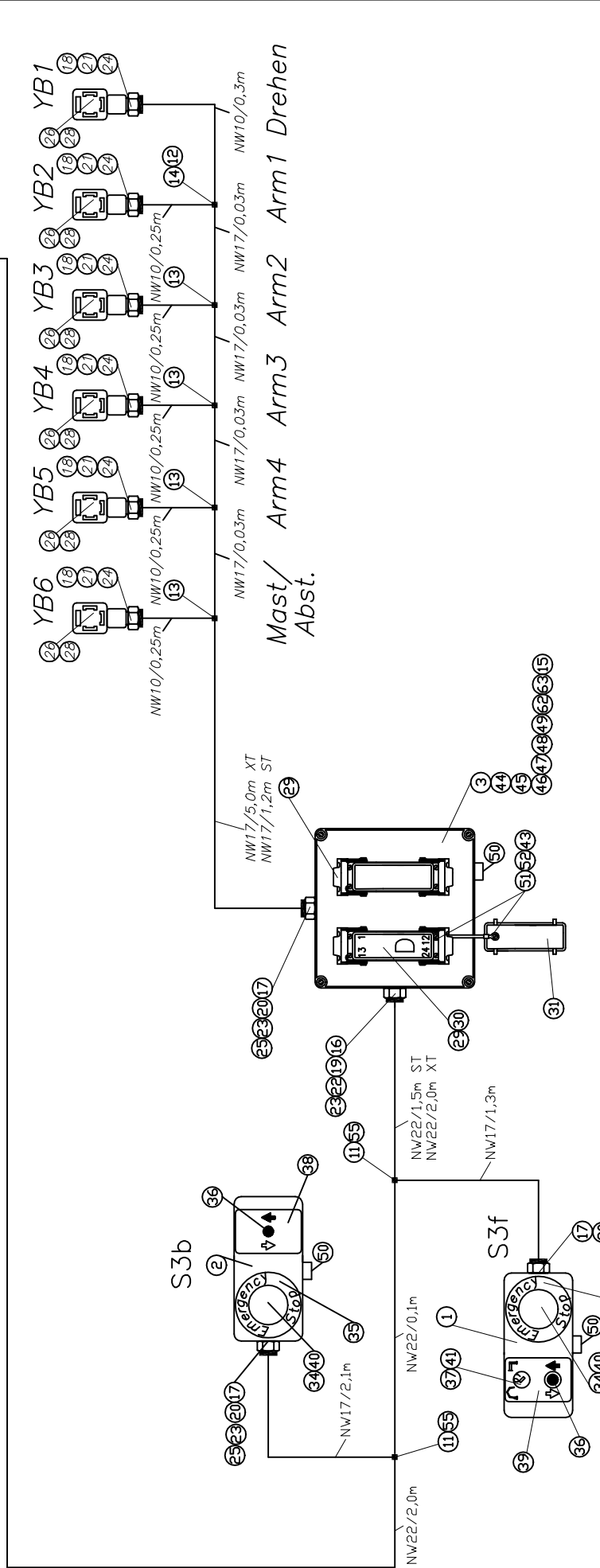
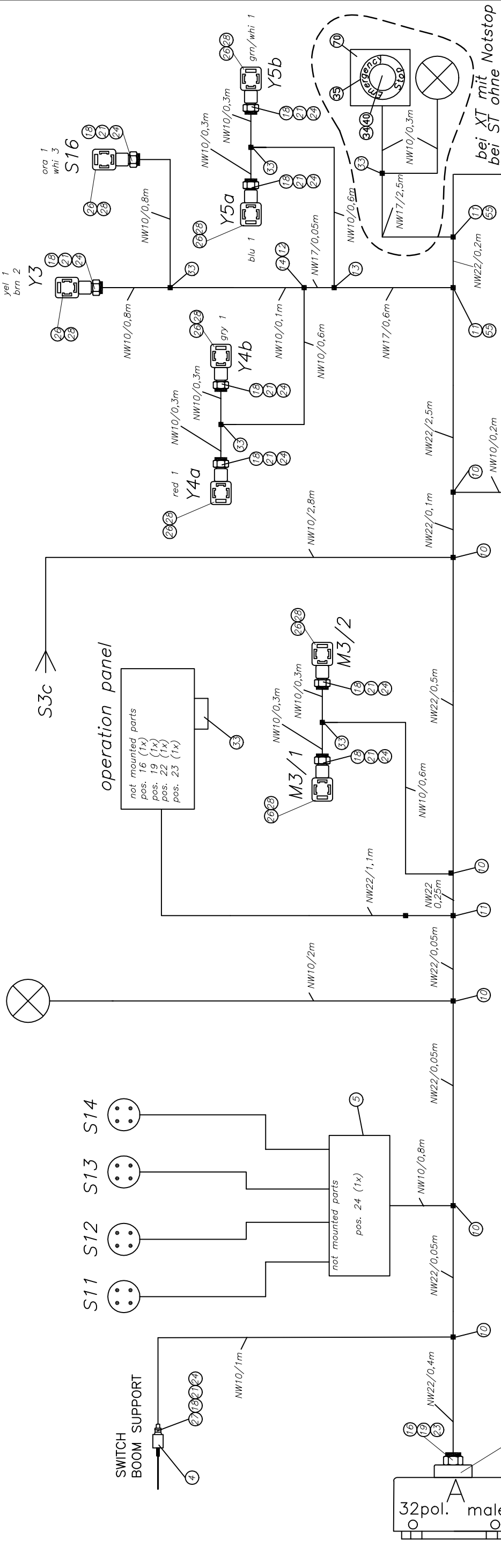

PLUG A

1	Masse
2	S11-S14
3	Reserve
4	AB/3
5	AB/1
6	AB/8
7	S3e
8	S3e
9	D/20
10	D/18
11	AB/6
12	AB/14
13	AB/15
14	AB/10
15	AB/11
16	light
17	AB/18
18	S11
19	S12
20	S13
21	S14
22	S16
23	AB/17
24	AB/12
25	Y3
26	Y4a
27	Y4b
28	Y5a
29	Y5b
30	M3-1
31	M3-2
32	AB/13

	scale	weight	
	own parts list		
	free dimension tolerance	DIN 7168 medium	
	date		name
	drawn		Körner
chkd.			
appd.			
change only with CAD			
issue	MODIFICATION	date	
a	siehe B 562063.doc	17.01.05	
		Hoh.	
		name	
		original	
replacement for		sheet	
B 56 2 063		1	
		of	
		4	



this information may not be copied by a third party. Subject to copyright (paragraph 1 no. 3 of (Urheberrechtsgesetz) from 14.06.1991)

kein Stecker! O.P.

S11 S12 S13 S14

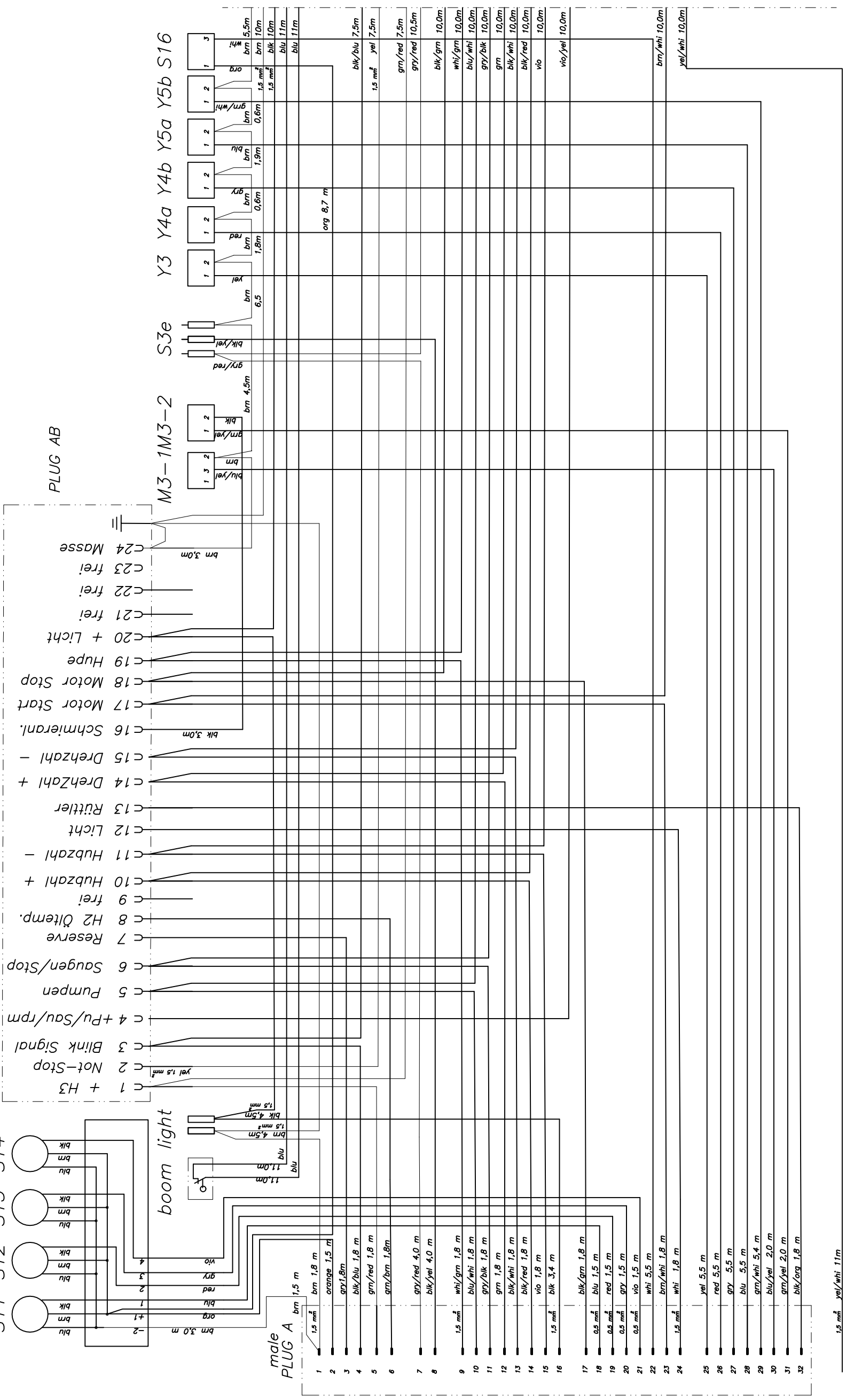

- Abst. Kl. 13
- Masse
- Masse
- Licht Kl.15
- Arm 1
- Arm 1
- N/S Blink
- Not/Stop Kl.14
- N/S Licht
- Motor Stop
- Hupe
- Pumpen
- Stop/Saugen
- r.p.m +
- r.p.m. -
- stroke +
- stroke -
- Freigabe Pult
- Motor Start
- Reserve Kl.16

PLUG A

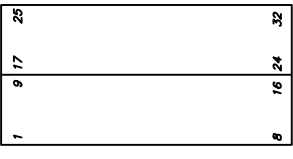

Waitzinger  
Baumaschinen  
Vertrieb und  
Service GmbH

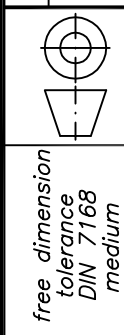

free dimension  
tolerance  
DIN 7168  
medium

scale

own parts list

cable loop  
pump

drawn	21.09.2004	name	Körner
chkd.			
appd.			
change only with CAD			
issue	MODIFICATION	date	name
a	siehe B 562063.doc	17.01.05	Hoh.

replacement for	
B 56 2 063	
sheet	2
of	4

this information may not be copied by a third party. Subject to copyright (paragraph 1 no. 3 of (Urheberrechtsgesetz) from 14.06.1991)

PLUG D

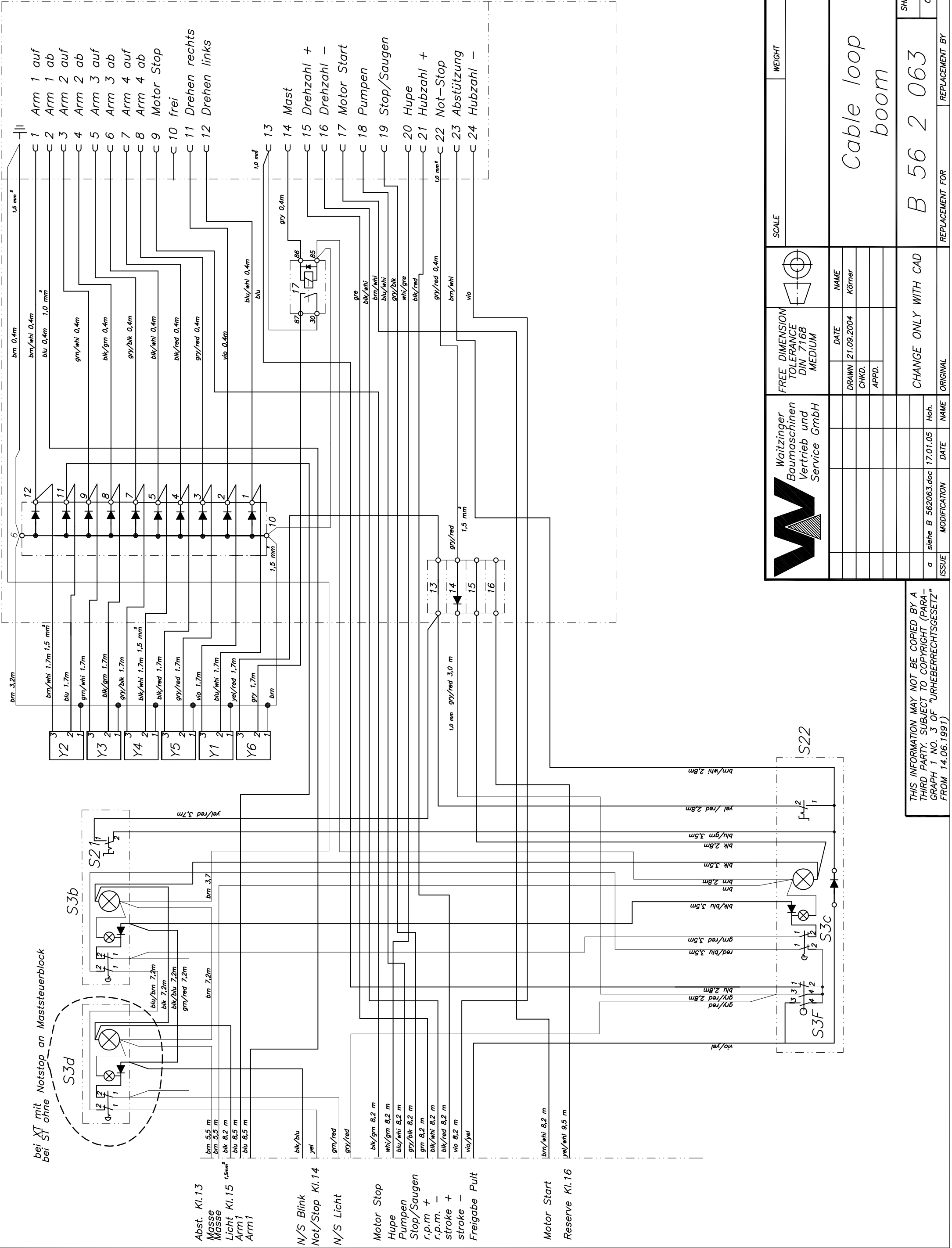

Waitzinger  
Baumaschinen  
Vertrieb und  
Service GmbH

FREE DIMENSION  
TOLERANCE  
DIN 7168  
MEDIUM

SCALE

WEIGHT

Cable loop  
boom

CHANGE ONLY WITH CAD

ISSUE	MODIFICATION	DATE	NAME	Hohe
a	siehe B 562063.doc	17.01.05		
DATE	21.09.2004			
NAME	Körner			
CHKD.				
APPD.				
REPLACEMENT FOR	B 56 2 063			
SHEET	3			
OF	4			

THIS INFORMATION MAY NOT BE COPIED BY A  
THIRD PARTY. SUBJECT TO COPYRIGHT (PARA-  
GRAPH 1 NO. 3 OF "URheberRECHTSGESETZ"  
FROM 14.06.1991)

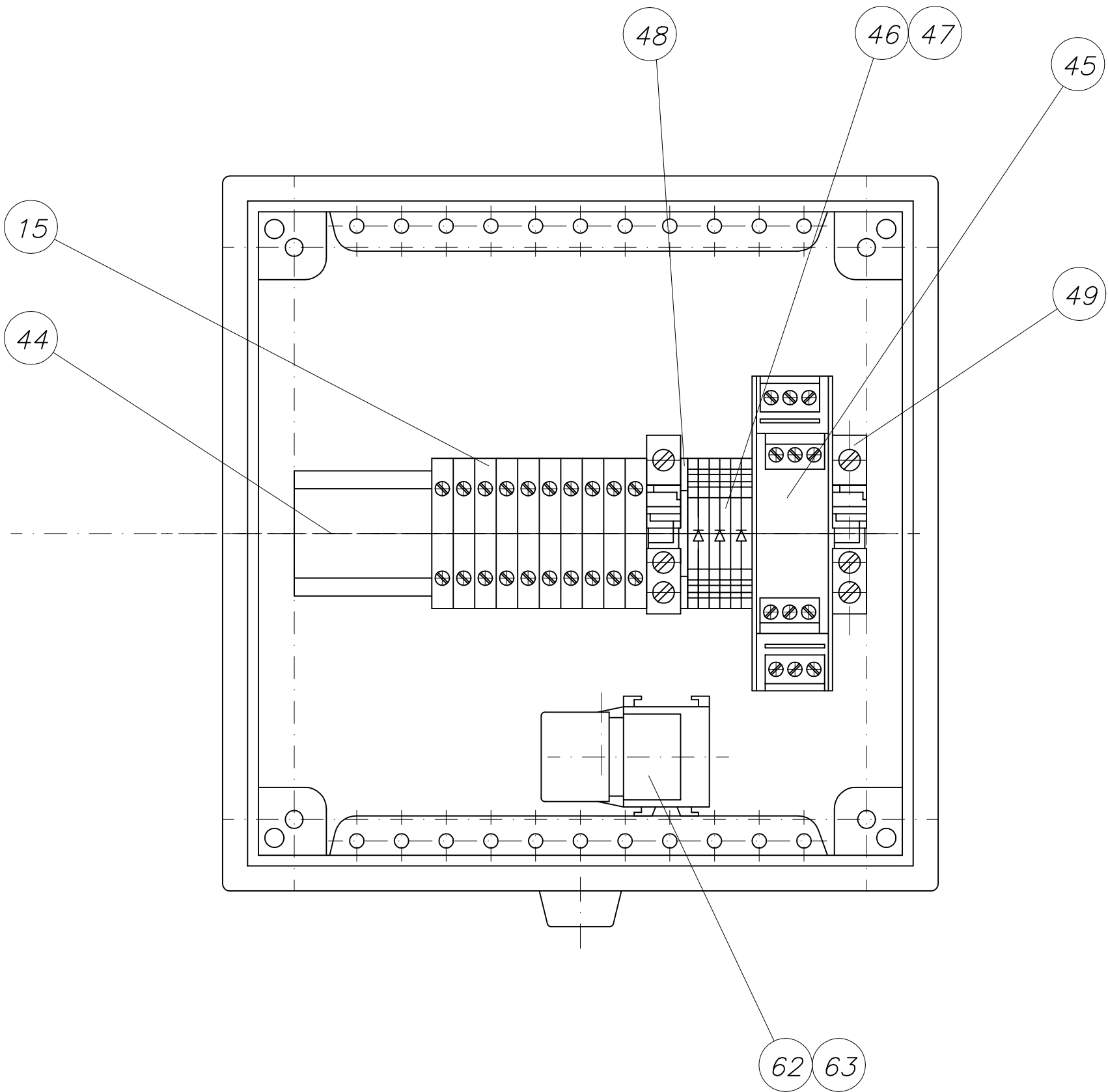

THIS INFORMATION MAY NOT BE COPIED BY A  
 THIRD PARTY. SUBJECT TO COPYRIGHT (PARA-  
 GRAPH 1 NO. 3 OF "URHEBERRECHTSGESETZ"  
 FROM 14.06.1991)

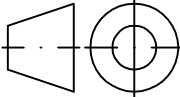
		Waitzinger Baumaschinen Vertrieb und Service GmbH		FREE DIMENSION TOLERANCE DIN 7168 MEDIUM				SCALE		WEIGHT	
					DATE	NAME		Cable loop boom			
				DRAWN	21.09.2004	Körner					
				CHKD.							
				APPD.							
				CHANGE ONLY WITH CAD				B 56 2 063			
								SHEET 4			
								OF 4			
ISSUE	MODIFICATION	DATE	NAME	ORIGINAL	REPLACEMENT FOR			REPLACEMENT BY			
a	siehe B 562063.doc	17.01.05	Hoh.								



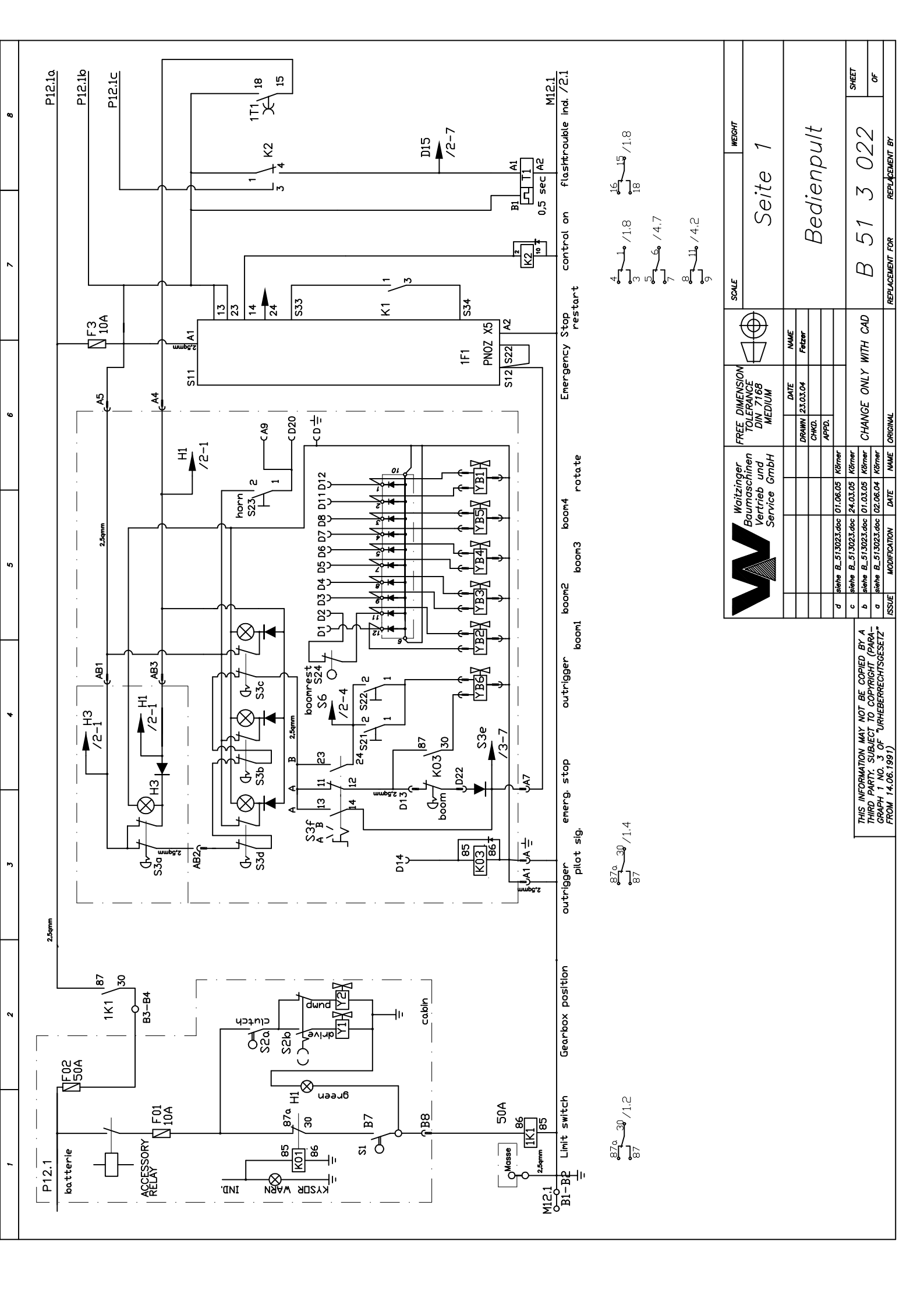

87<sup>a</sup> 30 / 1.2  
87

87<sup>a</sup> 30 / 1.4  
87

4 1 / 1.8  
3  
5 6 / 4.7  
7  
8 11 / 4.2  
9

SCALE		WEIGHT	
Seite 1			
Bedienpult			
FREE DIMENSION TOLERANCE DIN 7185 MEDIUM	DATE DRAWN 23.03.04	NAME Fetzer	
	CHKD.	APPD.	
d siehe B_513023.doc 01.06.05 Köhner			
c siehe B_513023.doc 24.03.05 Köhner			
b siehe B_513023.doc 01.03.05 Köhner			
a siehe B_513023.doc 02.06.04 Köhner			
ISSUE	MODIFICATION	DATE	NAME ORIGINAL
CHANGE ONLY WITH CAD			
REPLACEMENT FOR			SHEET
B 51 3 022			OF

THIS INFORMATION MAY NOT BE COPIED BY A THIRD PARTY. SUBJECT TO COPYRIGHT (PARAGRAPH 1 NO. 3 OF "URheberRECHTSGESETZ" FROM 14.06.1991)

P12.2a P12.2b P12.2c M12.2 /1.8 M12.2 /3.1

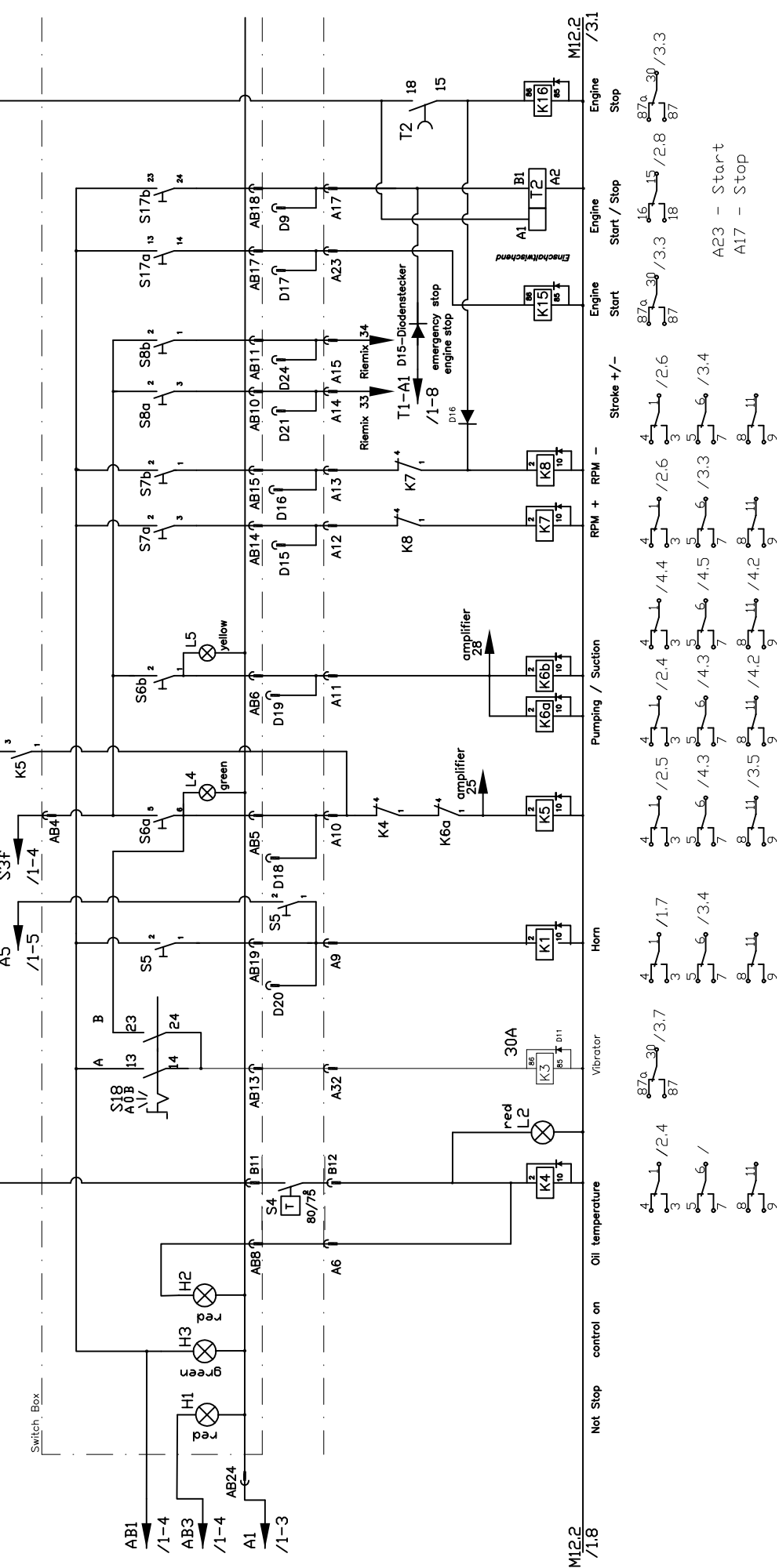

SCALE		WEIGHT	
Seite 2		Bedienpult	
FREE DIMENSION TOLERANCE DIN 7185 MEDIUM	DATE	NAME	
	23.03.04	Fetzer	
	CHKD.		
	APPD.		
d siehe B_513023.doc	01.06.05	Körner	
c siehe B_513023.doc	24.03.05	Körner	
b siehe B_513023.doc	01.03.05	Körner	
a siehe B_513023.doc	02.06.04	Körner	
ISSUE	MODIFICATION	DATE	NAME ORIGINAL

THIS INFORMATION MAY NOT BE COPIED BY A THIRD PARTY. SUBJECT TO COPYRIGHT (PARAGRAPH 1 NO. 3 OF "URheberRECHTSGESETZ" FROM 14.06.1991)

CHANGE ONLY WITH CAD

REPLACEMENT FOR B 51 3 022

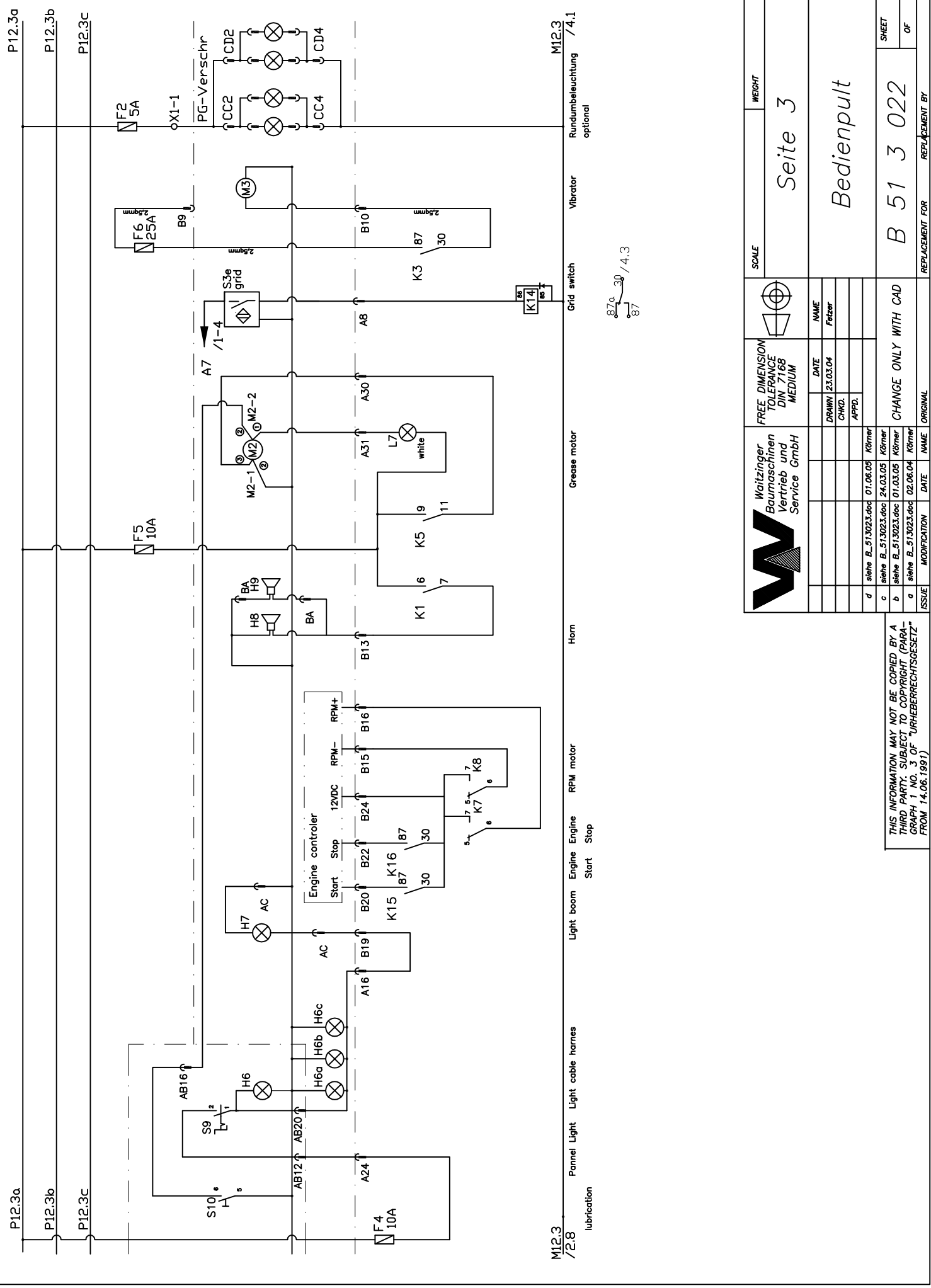

SCALE		WEIGHT	
Seite 3		Bedienpult	
FREE DIMENSION TOLERANCE DIN 7185 MEDIUM	DATE	NAME	
	23.03.04	Fetzer	
CHKD.			
APPD.			
d	siehe B_513023.doc	01.06.05	Körner
c	siehe B_513023.doc	24.03.05	Körner
b	siehe B_513023.doc	01.03.05	Körner
a	siehe B_513023.doc	02.06.04	Körner
ISSUE	MODIFICATION	DATE	NAME
CHANGE ONLY WITH CAD			
REPLACEMENT FOR			
B 51 3 022			
SHEET			
OF			

THIS INFORMATION MAY NOT BE COPIED BY A THIRD PARTY. SUBJECT TO COPYRIGHT (PARAGRAPH 1 NO. 3 OF "URheberRECHTSGESETZ" FROM 14.06.1991)

M12.3 / 2.8 Pannel Light lubrication  
 Light boom  
 Engine Start  
 Engine RPM motor  
 Horn  
 Grease motor  
 Grid switch  
 Vibrator  
 Rundumbeleuchtung / 4.1 optional



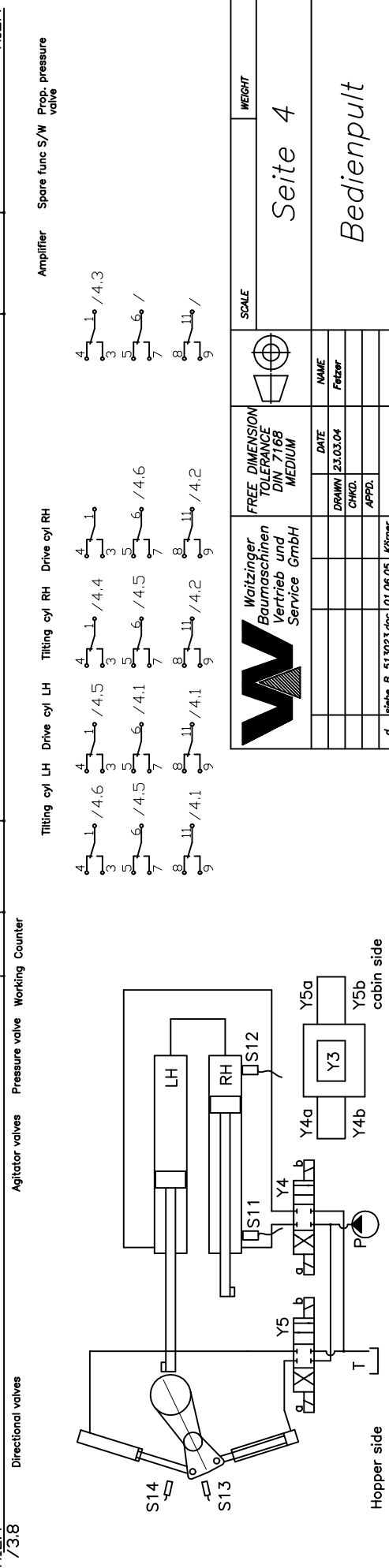
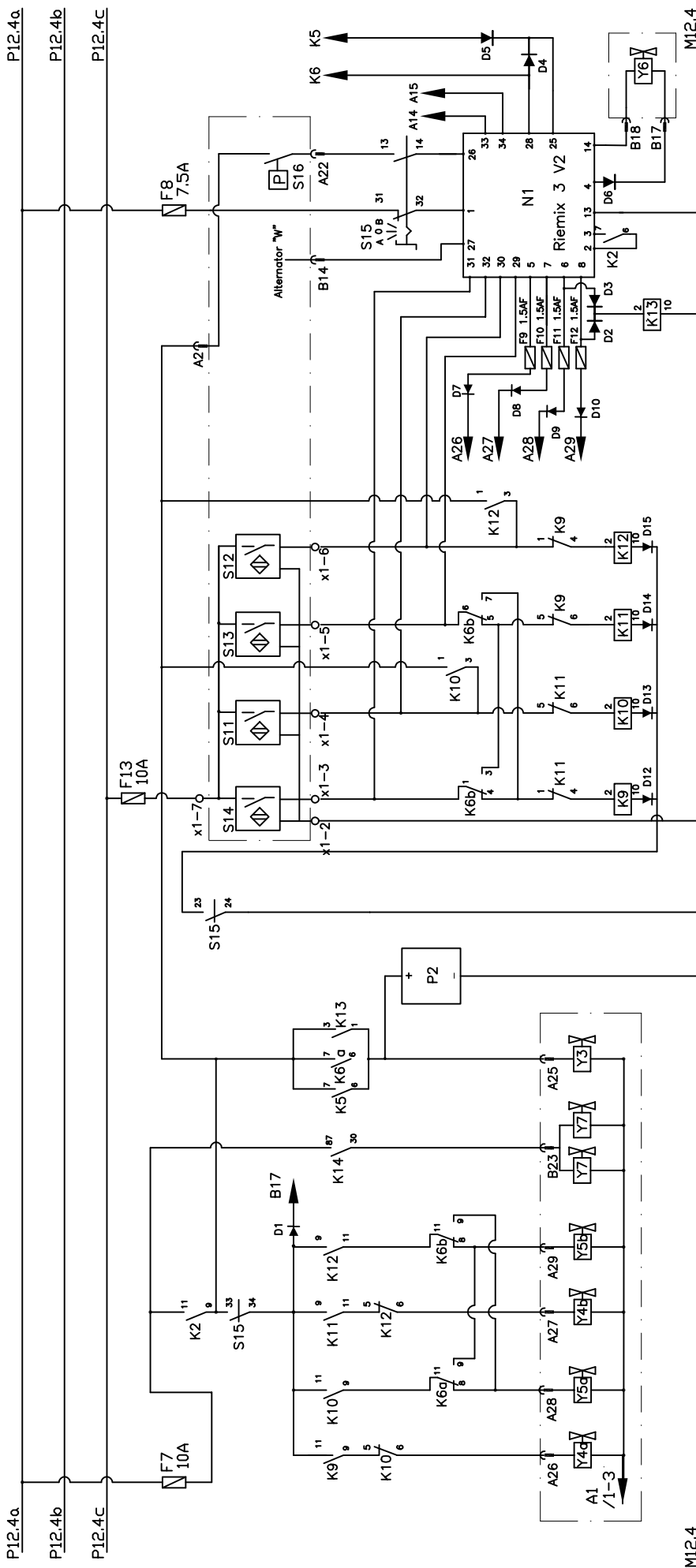

Directional valves    Agitator valves    Pressure valve    Working Counter

Hopper side    cabin side

THIS INFORMATION MAY NOT BE COPIED BY A THIRD PARTY. SUBJECT TO COPYRIGHT (PARAGRAPH 1 NO. 3 OF "URheberRECHTSGESETZ" FROM 14.06.1991)

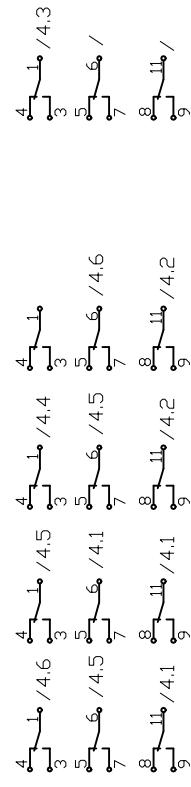

Amplifier    Spare func S/W    Prop. pressure valve

SCALE		WEIGHT	
Seite 4		Bedienpult	
FREE DIMENSION TOLERANCE DIN 7185 MEDIUM		DATE	
DRAWN 23.03.04		NAME	
CHKD.		Fetzer	
APPD.			
d siehe B_513023.doc 01.06.05 Körner		ISSUE	
c siehe B_513023.doc 24.03.05 Körner		MODIFICATION	
b siehe B_513023.doc 01.03.05 Körner		DATE	
a siehe B_513023.doc 02.06.04 Körner		NAME	
ORIGINAL		REPLACEMENT FOR	
CHANGE ONLY WITH CAD		B 51 3 022	
SHEET		OF	



**Check book for Waitzinger  
Concrete pump**

**Concrete pump:**

<b>Type:</b>	<b>Serial No.</b>
HP 12523	204460

**Placing boom:**

<b>Type:</b>	<b>Serial No.</b>
36R4XT	204460

**Truck:**

**Manufacturer**

<b>Type:</b>	<b>Serial No.</b>
--------------	-------------------

**Record sheet for regular inspections by the competent inspection personnel**

Instpection report No.: ..... Date: .....

There are – are no – reasons why the machine should not continue to be operated.

Reinspection is – is not – required for .....

Competent inspector:

.....  
(Date, City)

.....  
(Name)

.....  
(Signature)

Instpection report No.: ..... Date: .....

There are – are no – reasons why the machine should not continue to be operated.

Reinspection is – is not – required for .....

Competent inspector:

.....  
(Date, City)

.....  
(Name)

.....  
(Signature)

Instpection report No.: ..... Date: .....

There are – are no – reasons why the machine should not continue to be operated.

Reinspection is – is not – required for .....

Competent inspector:

.....  
(Date, City)

.....  
(Name)

.....  
(Signature)

**Record sheet for regular inspections by the competent inspection personnel**

Instpection report No.: ..... Date: .....

There are – are no – reasons why the machine should not continue to be operated.

Reinspection is – is not – required for .....

Competent inspector:

.....  
(Date, City)

.....  
(Name)

.....  
(Signature)

Instpection report No.: ..... Date: .....

There are – are no – reasons why the machine should not continue to be operated.

Reinspection is – is not – required for .....

Competent inspector:

.....  
(Date, City)

.....  
(Name)

.....  
(Signature)

Instpection report No.: ..... Date: .....

There are – are no – reasons why the machine should not continue to be operated.

Reinspection is – is not – required for .....

Competent inspector:

.....  
(Date, City)

.....  
(Name)

.....  
(Signature)

**Record sheet for regular inspections by the competent inspection personnel**

Instpection report No.: ..... Date: .....

There are – are no – reasons why the machine should not continue to be operated.

Reinspection is – is not – required for .....

Competent inspector:

.....  
(Date, City)

.....  
(Name)

.....  
(Signature)

Instpection report No.: ..... Date: .....

There are – are no – reasons why the machine should not continue to be operated.

Reinspection is – is not – required for .....

Competent inspector:

.....  
(Date, City)

.....  
(Name)

.....  
(Signature)

Instpection report No.: ..... Date: .....

There are – are no – reasons why the machine should not continue to be operated.

Reinspection is – is not – required for .....

Competent inspector:

.....  
(Date, City)

.....  
(Name)

.....  
(Signature)



**Record sheet for regular inspections by the competent inspection personnel**

Instpection report No.: ..... Date: .....

There are – are no – reasons why the machine should not continue to be operated.

Reinspection is – is not – required for .....

Competent inspector:

.....  
(Date, City)

.....  
(Name)

.....  
(Signature)

Instpection report No.: ..... Date: .....

There are – are no – reasons why the machine should not continue to be operated.

Reinspection is – is not – required for .....

Competent inspector:

.....  
(Date, City)

.....  
(Name)

.....  
(Signature)

Instpection report No.: ..... Date: .....

There are – are no – reasons why the machine should not continue to be operated.

Reinspection is – is not – required for .....

Competent inspector:

.....  
(Date, City)

.....  
(Name)

.....  
(Signature)

## assembly groupes - structuring

with description from the assembly groups and parts respectively

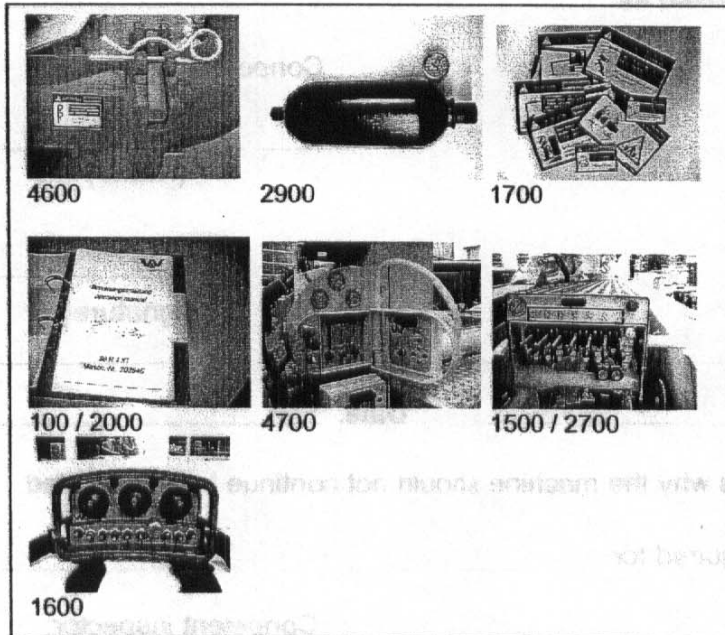
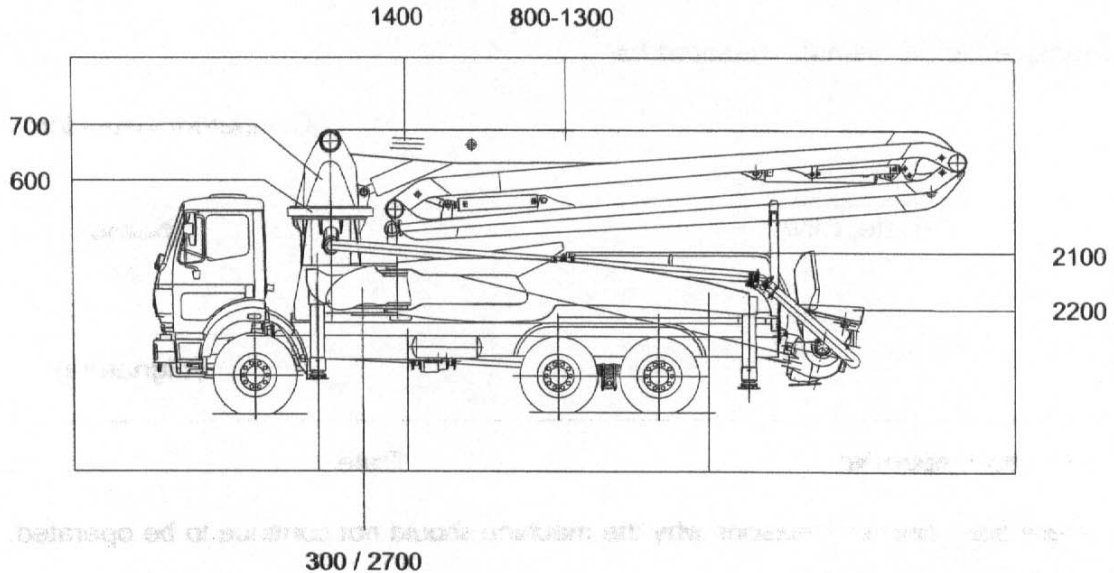

- 1500 hydraulic system and hydraulic valves
- 1600 electric equipment
- 1700 sticker sets

### concrete pump:

- 2000 documents
- 2100 drive assembly
- 2200 gear box
- 2300 hydraulic pump (main)
- 2400 oil-tank
- 2500 drive shaft
- 2600 fuel equipment
- 2700 hydraulic control system
- 2800 oil-cooler
- 2900 accumulator
- 3000 central lubrication
- 3100 hydraulic motor
- 3200 hydraulic lines
- 3300 air compressor
- 3400 control panel
- 3500 concrete pump
- 3700 S-valve
- 3800 hopper
- 4000 vacuum pump
- aggregate
- 4100 sub frame
- 4200 water tank
- 4300 axle
- 4400 water pump
- 4500 vibrator
- 4600 safety guards, equipment
- 4700 electrical system

### concrete boom:

- 100 documents
- 200 sub frame
- 300 outrigger front R+L
- 400 outrigger rear L+R
- 500 pedestal
- slewing head with ball pivot
- 700 slewing head with slewing column
- 800-1300 boom (joint A-E)
- 1400 concrete delivery line

# Inspection report for concrete booms

Inspection report -Nr:	Machine-Nr	Hours of operation:
		Concrete output m <sup>3</sup> :
Company:	Post code:	City:
Boom Type:	Boom Nr.	NL <span style="margin-left: 100px;">WV</span>

**Proof – Result of the Tests**

without defects	defects	reinspection required	shut down
<input type="checkbox"/>	<input type="checkbox"/>	<input type="checkbox"/>	<input type="checkbox"/>

Reinspection until date: .....

**Error code:**

- |                  |                     |                   |                          |
|------------------|---------------------|-------------------|--------------------------|
| 00 no objections | 08 corrosion        | 16 porous         | 24 deformation           |
| 01 cracks        | 09 lacquer failures | 17 burned through | 25 bear movement         |
| 02 broken        | 10 fraying          | 18 not fixed      | 26 lubrication           |
| 03 leaky         | 11 scratched        | 19 clomp          | 27 readability           |
| 04 no function   | 12 bendet           | 20 sawing         | 28 missing components    |
| 05 low lifetime  | 13 noises           | 21 contaminated   | 29 hydraulical           |
| 06 worn out      | 14 vibration        | 22 bad contact    | 30 electrical            |
| 07 dirt          | 15 miscellaneous    | 23 temperature    | 31 reinspection required |

<p><b>100 documents</b></p> <p>101 instruction manual <input type="checkbox"/> <input type="checkbox"/> <input type="checkbox"/> <input type="checkbox"/> <input type="checkbox"/></p> <p>102 spare parts list <input type="checkbox"/> <input type="checkbox"/> <input type="checkbox"/> <input type="checkbox"/> <input type="checkbox"/></p> <p><b>200 sub frame</b></p> <p>201 frame connection cpl. <input type="checkbox"/> <input type="checkbox"/> <input type="checkbox"/> <input type="checkbox"/> <input type="checkbox"/></p> <p><b>300 outrigger front R+L</b></p> <p>301 transportation safety device <input type="checkbox"/> <input type="checkbox"/> <input type="checkbox"/> <input type="checkbox"/> <input type="checkbox"/></p> <p>302 outrigger <input type="checkbox"/> <input type="checkbox"/> <input type="checkbox"/> <input type="checkbox"/> <input type="checkbox"/></p> <p>303 extension box <input type="checkbox"/> <input type="checkbox"/> <input type="checkbox"/> <input type="checkbox"/> <input type="checkbox"/></p> <p>304 locking device <input type="checkbox"/> <input type="checkbox"/> <input type="checkbox"/> <input type="checkbox"/> <input type="checkbox"/></p> <p>305 slewing bearing <input type="checkbox"/> <input type="checkbox"/> <input type="checkbox"/> <input type="checkbox"/> <input type="checkbox"/></p> <p>306 tum locking device <input type="checkbox"/> <input type="checkbox"/> <input type="checkbox"/> <input type="checkbox"/> <input type="checkbox"/></p> <p>307 support safeguard <input type="checkbox"/> <input type="checkbox"/> <input type="checkbox"/> <input type="checkbox"/> <input type="checkbox"/></p> <p>308 support plate <input type="checkbox"/> <input type="checkbox"/> <input type="checkbox"/> <input type="checkbox"/> <input type="checkbox"/></p> <p>309 fixing of jack cylinder <input type="checkbox"/> <input type="checkbox"/> <input type="checkbox"/> <input type="checkbox"/> <input type="checkbox"/></p> <p>310 jack cylinder <input type="checkbox"/> <input type="checkbox"/> <input type="checkbox"/> <input type="checkbox"/> <input type="checkbox"/></p>	<p>311 swing cylinder <input type="checkbox"/> <input type="checkbox"/> <input type="checkbox"/> <input type="checkbox"/> <input type="checkbox"/></p> <p>312 telescopic-cylinder <input type="checkbox"/> <input type="checkbox"/> <input type="checkbox"/> <input type="checkbox"/> <input type="checkbox"/></p> <p>313 pressure adjustment <input type="checkbox"/> <input type="checkbox"/> <input type="checkbox"/> <input type="checkbox"/> <input type="checkbox"/></p> <p><b>400 outrigger rear L+R</b></p> <p>401 transportation safety device <input type="checkbox"/> <input type="checkbox"/> <input type="checkbox"/> <input type="checkbox"/> <input type="checkbox"/></p> <p>402 outrigger <input type="checkbox"/> <input type="checkbox"/> <input type="checkbox"/> <input type="checkbox"/> <input type="checkbox"/></p> <p>403 extension box <input type="checkbox"/> <input type="checkbox"/> <input type="checkbox"/> <input type="checkbox"/> <input type="checkbox"/></p> <p>405 locking device <input type="checkbox"/> <input type="checkbox"/> <input type="checkbox"/> <input type="checkbox"/> <input type="checkbox"/></p> <p><b>Notes:</b></p> <hr/> <hr/> <hr/> <hr/> <hr/>
--	--

# Inspection report for concrete booms

Inspection report Nr: \_\_\_\_\_ Boom type: \_\_\_\_\_ Machine-Nr: \_\_\_\_\_

**Error code:**

- |                  |                     |                   |                          |
|------------------|---------------------|-------------------|--------------------------|
| 00 no objections | 08 corrosion        | 16 porous         | 24 deformation           |
| 01 cracks        | 09 lacquer failures | 17 burned through | 25 bear movement         |
| 02 broken        | 10 fraying          | 18 not fixed      | 26 lubrication           |
| 03 leaky         | 11 scratched        | 19 clump          | 27 readability           |
| 04 no function   | 12 bendet           | 20 sawing         | 28 missing components    |
| 05 low lifetime  | 13 noises           | 21 contaminated   | 29 hydraulical           |
| 06 worn out      | 14 vibration        | 22 bad contact    | 30 electrical            |
| 07 dirt          | 15 miscellaneous    | 23 temperature    | 31 reinspection required |

<p>406 slewing bearing <input type="checkbox"/> <input type="checkbox"/> <input type="checkbox"/> <input type="checkbox"/> <input type="checkbox"/></p> <p>407 turn locking device <input type="checkbox"/> <input type="checkbox"/> <input type="checkbox"/> <input type="checkbox"/> <input type="checkbox"/></p> <p>408 support safeguard <input type="checkbox"/> <input type="checkbox"/> <input type="checkbox"/> <input type="checkbox"/> <input type="checkbox"/></p> <p>409 support plate <input type="checkbox"/> <input type="checkbox"/> <input type="checkbox"/> <input type="checkbox"/> <input type="checkbox"/></p> <p>410 fixing of jack cylinder <input type="checkbox"/> <input type="checkbox"/> <input type="checkbox"/> <input type="checkbox"/> <input type="checkbox"/></p> <p>411 jack cylinder <input type="checkbox"/> <input type="checkbox"/> <input type="checkbox"/> <input type="checkbox"/> <input type="checkbox"/></p> <p>412 swing cylinder <input type="checkbox"/> <input type="checkbox"/> <input type="checkbox"/> <input type="checkbox"/> <input type="checkbox"/></p> <p>413 telescopic cylinder <input type="checkbox"/> <input type="checkbox"/> <input type="checkbox"/> <input type="checkbox"/> <input type="checkbox"/></p> <p><b>500 pedestal</b></p> <p>501 pedestal mounting <input type="checkbox"/> <input type="checkbox"/> <input type="checkbox"/> <input type="checkbox"/> <input type="checkbox"/></p> <p>502 sub frame <input type="checkbox"/> <input type="checkbox"/> <input type="checkbox"/> <input type="checkbox"/> <input type="checkbox"/></p> <p>503 truck frame <input type="checkbox"/> <input type="checkbox"/> <input type="checkbox"/> <input type="checkbox"/> <input type="checkbox"/></p> <p>504 pedestal (structure) <input type="checkbox"/> <input type="checkbox"/> <input type="checkbox"/> <input type="checkbox"/> <input type="checkbox"/></p> <p>505 boom valve without leaking <input type="checkbox"/> <input type="checkbox"/> <input type="checkbox"/> <input type="checkbox"/> <input type="checkbox"/></p> <p>506 boom rest <input type="checkbox"/> <input type="checkbox"/> <input type="checkbox"/> <input type="checkbox"/> <input type="checkbox"/></p> <p>507 transportation safety device <input type="checkbox"/> <input type="checkbox"/> <input type="checkbox"/> <input type="checkbox"/> <input type="checkbox"/></p> <p>508 hydraulic line <input type="checkbox"/> <input type="checkbox"/> <input type="checkbox"/> <input type="checkbox"/> <input type="checkbox"/></p> <p><b>600 slewing head with ball pivot</b></p> <p>601 slewing head <input type="checkbox"/> <input type="checkbox"/> <input type="checkbox"/> <input type="checkbox"/> <input type="checkbox"/></p> <p>602 ball pivot ring <input type="checkbox"/> <input type="checkbox"/> <input type="checkbox"/> <input type="checkbox"/> <input type="checkbox"/></p> <p>603 mounting ball pivot ring <input type="checkbox"/> <input type="checkbox"/> <input type="checkbox"/> <input type="checkbox"/> <input type="checkbox"/></p> <p>604 drive pinion <input type="checkbox"/> <input type="checkbox"/> <input type="checkbox"/> <input type="checkbox"/> <input type="checkbox"/></p>	<p>605 slewing drive mounting <input type="checkbox"/> <input type="checkbox"/> <input type="checkbox"/> <input type="checkbox"/> <input type="checkbox"/></p> <p>606 slewing stop device <input type="checkbox"/> <input type="checkbox"/> <input type="checkbox"/> <input type="checkbox"/> <input type="checkbox"/></p> <p>607 slewing drive (tooth backlash) <input type="checkbox"/> <input type="checkbox"/> <input type="checkbox"/> <input type="checkbox"/> <input type="checkbox"/></p> <p>608 slewing drive <input type="checkbox"/> <input type="checkbox"/> <input type="checkbox"/> <input type="checkbox"/> <input type="checkbox"/></p> <p>609 brake function <input type="checkbox"/> <input type="checkbox"/> <input type="checkbox"/> <input type="checkbox"/> <input type="checkbox"/></p> <p>610 speed <input type="checkbox"/> <input type="checkbox"/> <input type="checkbox"/> <input type="checkbox"/> <input type="checkbox"/></p> <p>611 pressure setting <input type="checkbox"/> <input type="checkbox"/> <input type="checkbox"/> <input type="checkbox"/> <input type="checkbox"/></p> <p>612 hydraulic lines <input type="checkbox"/> <input type="checkbox"/> <input type="checkbox"/> <input type="checkbox"/> <input type="checkbox"/></p> <p><b>700 slewing head with slewing column</b></p> <p>701 slewing head <input type="checkbox"/> <input type="checkbox"/> <input type="checkbox"/> <input type="checkbox"/> <input type="checkbox"/></p> <p>702 slewing column bearing <input type="checkbox"/> <input type="checkbox"/> <input type="checkbox"/> <input type="checkbox"/> <input type="checkbox"/></p> <p>703 slewing drive (tooth backlash) <input type="checkbox"/> <input type="checkbox"/> <input type="checkbox"/> <input type="checkbox"/> <input type="checkbox"/></p> <p>704 speed <input type="checkbox"/> <input type="checkbox"/> <input type="checkbox"/> <input type="checkbox"/> <input type="checkbox"/></p> <p>705 pressure settings <input type="checkbox"/> <input type="checkbox"/> <input type="checkbox"/> <input type="checkbox"/> <input type="checkbox"/></p> <p>706 hydraulic lines <input type="checkbox"/> <input type="checkbox"/> <input type="checkbox"/> <input type="checkbox"/> <input type="checkbox"/></p> <p>707 swivel cylinder <input type="checkbox"/> <input type="checkbox"/> <input type="checkbox"/> <input type="checkbox"/> <input type="checkbox"/></p> <p>Notes:</p> <hr/> <hr/> <hr/> <hr/>
---	---

# Inspection report for concrete booms

Inspection report Nr: \_\_\_\_\_ Boom type: \_\_\_\_\_ Machine-Nr: \_\_\_\_\_

**Error code:**

- |                  |                     |                   |                          |
|------------------|---------------------|-------------------|--------------------------|
| 00 no objections | 08 corrosion        | 16 porous         | 24 deformation           |
| 01 cracks        | 09 lacquer failures | 17 burned through | 25 bear movement         |
| 02 broken        | 10 fraying          | 18 not fixed      | 26 lubrication           |
| 03 leaky         | 11 scratched        | 19 clomp          | 27 readability           |
| 04 no function   | 12 bendet           | 20 sawing         | 28 missing components    |
| 05 low lifetime  | 13 noises           | 21 contaminated   | 29 hydraulical           |
| 06 worn out      | 14 vibration        | 22 bad contact    | 30 electrical            |
| 07 dirt          | 15 miscellaneous    | 23 temperature    | 31 reinspection required |

<p><b>800 boom</b>                    <input type="checkbox"/> <input type="checkbox"/> <input type="checkbox"/> <input type="checkbox"/> <input type="checkbox"/></p> <p>801 „Arm1“                    <input type="checkbox"/> <input type="checkbox"/> <input type="checkbox"/> <input type="checkbox"/> <input type="checkbox"/></p> <p>802 bracket conveying line <input type="checkbox"/> <input type="checkbox"/> <input type="checkbox"/> <input type="checkbox"/> <input type="checkbox"/></p> <p>803 Drop hook                <input type="checkbox"/> <input type="checkbox"/> <input type="checkbox"/> <input type="checkbox"/> <input type="checkbox"/></p> <p>804 „Arm 2“                    <input type="checkbox"/> <input type="checkbox"/> <input type="checkbox"/> <input type="checkbox"/> <input type="checkbox"/></p> <p>805 bracket conveying line <input type="checkbox"/> <input type="checkbox"/> <input type="checkbox"/> <input type="checkbox"/> <input type="checkbox"/></p> <p>806 Drop hook                <input type="checkbox"/> <input type="checkbox"/> <input type="checkbox"/> <input type="checkbox"/> <input type="checkbox"/></p> <p>807 „Arm 3“                    <input type="checkbox"/> <input type="checkbox"/> <input type="checkbox"/> <input type="checkbox"/> <input type="checkbox"/></p> <p>808 bracket conveying line <input type="checkbox"/> <input type="checkbox"/> <input type="checkbox"/> <input type="checkbox"/> <input type="checkbox"/></p> <p>809 guidance and interlock of the arm <input type="checkbox"/> <input type="checkbox"/> <input type="checkbox"/> <input type="checkbox"/> <input type="checkbox"/></p> <p>810 „Arm 4“                    <input type="checkbox"/> <input type="checkbox"/> <input type="checkbox"/> <input type="checkbox"/> <input type="checkbox"/></p> <p>811 bracket conveying line <input type="checkbox"/> <input type="checkbox"/> <input type="checkbox"/> <input type="checkbox"/> <input type="checkbox"/></p> <p>812 guidance and interlock of the arm <input type="checkbox"/> <input type="checkbox"/> <input type="checkbox"/> <input type="checkbox"/> <input type="checkbox"/></p> <p>813 „Arm 5“                    <input type="checkbox"/> <input type="checkbox"/> <input type="checkbox"/> <input type="checkbox"/> <input type="checkbox"/></p> <p>814 bracket conveying line <input type="checkbox"/> <input type="checkbox"/> <input type="checkbox"/> <input type="checkbox"/> <input type="checkbox"/></p> <p>815 guidance and interlock of the arm <input type="checkbox"/> <input type="checkbox"/> <input type="checkbox"/> <input type="checkbox"/> <input type="checkbox"/></p> <p><b>900 joint „A“</b>                <input type="checkbox"/> <input type="checkbox"/> <input type="checkbox"/> <input type="checkbox"/> <input type="checkbox"/></p> <p>901 boom                        <input type="checkbox"/> <input type="checkbox"/> <input type="checkbox"/> <input type="checkbox"/> <input type="checkbox"/></p> <p>902 link lever                 <input type="checkbox"/> <input type="checkbox"/> <input type="checkbox"/> <input type="checkbox"/> <input type="checkbox"/></p> <p>903 forcing rod                <input type="checkbox"/> <input type="checkbox"/> <input type="checkbox"/> <input type="checkbox"/> <input type="checkbox"/></p> <p>904 pin                         <input type="checkbox"/> <input type="checkbox"/> <input type="checkbox"/> <input type="checkbox"/> <input type="checkbox"/></p> <p>905 cylinder                  <input type="checkbox"/> <input type="checkbox"/> <input type="checkbox"/> <input type="checkbox"/> <input type="checkbox"/></p>	<p>906 boom speed                <input type="checkbox"/> <input type="checkbox"/> <input type="checkbox"/> <input type="checkbox"/> <input type="checkbox"/></p> <p>907 pressure settings        <input type="checkbox"/> <input type="checkbox"/> <input type="checkbox"/> <input type="checkbox"/> <input type="checkbox"/></p> <p>908 hydraulic lines           <input type="checkbox"/> <input type="checkbox"/> <input type="checkbox"/> <input type="checkbox"/> <input type="checkbox"/></p> <p>909 load holding valve (piston side) <input type="checkbox"/> <input type="checkbox"/> <input type="checkbox"/> <input type="checkbox"/> <input type="checkbox"/></p> <p>910 load holding valve (rod side) <input type="checkbox"/> <input type="checkbox"/> <input type="checkbox"/> <input type="checkbox"/> <input type="checkbox"/></p> <p><b>1000 joint „B“</b></p> <p>1001 boom                      <input type="checkbox"/> <input type="checkbox"/> <input type="checkbox"/> <input type="checkbox"/> <input type="checkbox"/></p> <p>1002 link lever                <input type="checkbox"/> <input type="checkbox"/> <input type="checkbox"/> <input type="checkbox"/> <input type="checkbox"/></p> <p>1003 forcing rod               <input type="checkbox"/> <input type="checkbox"/> <input type="checkbox"/> <input type="checkbox"/> <input type="checkbox"/></p> <p>1004 pin                        <input type="checkbox"/> <input type="checkbox"/> <input type="checkbox"/> <input type="checkbox"/> <input type="checkbox"/></p> <p>1005 cylinder                 <input type="checkbox"/> <input type="checkbox"/> <input type="checkbox"/> <input type="checkbox"/> <input type="checkbox"/></p> <p>1006 boom speed               <input type="checkbox"/> <input type="checkbox"/> <input type="checkbox"/> <input type="checkbox"/> <input type="checkbox"/></p> <p>1007 pressure settings       <input type="checkbox"/> <input type="checkbox"/> <input type="checkbox"/> <input type="checkbox"/> <input type="checkbox"/></p> <p>1008 hydraulic lines         <input type="checkbox"/> <input type="checkbox"/> <input type="checkbox"/> <input type="checkbox"/> <input type="checkbox"/></p> <p>1009 load holding valve (piston side) <input type="checkbox"/> <input type="checkbox"/> <input type="checkbox"/> <input type="checkbox"/> <input type="checkbox"/></p> <p>1010 load holding valve (rod side) <input type="checkbox"/> <input type="checkbox"/> <input type="checkbox"/> <input type="checkbox"/> <input type="checkbox"/></p> <p>Notes:</p> <hr/> <hr/> <hr/> <hr/>
---	--

# Inspection report for concrete booms

Inspection report Nr: \_\_\_\_\_ Boom type: \_\_\_\_\_ Machine-Nr: \_\_\_\_\_

**Error code:**

00 no objections	08 corrosion	16 porous	24 deformation
01 cracks	09 lacquer failures	17 burned through	25 bear movement
02 broken	10 fraying	18 not fixed	26 lubrication
03 leaky	11 scratched	19 clomp	27 readability
04 no function	12 bendet	20 sawing	28 missing components
05 low lifetime	13 noises	21 contaminated	29 hydraulic
06 worn out	14 vibration	22 bad contact	30 electrical
07 dirt	15 miscellaneous	23 temperature	31 reinspection required

**1100 joint "C"**

1101 boom	<input type="checkbox"/>	<input type="checkbox"/>	<input type="checkbox"/>	<input type="checkbox"/>	<input type="checkbox"/>
1102 link lever	<input type="checkbox"/>	<input type="checkbox"/>	<input type="checkbox"/>	<input type="checkbox"/>	<input type="checkbox"/>
1103 forcing rod	<input type="checkbox"/>	<input type="checkbox"/>	<input type="checkbox"/>	<input type="checkbox"/>	<input type="checkbox"/>
1104 pin	<input type="checkbox"/>	<input type="checkbox"/>	<input type="checkbox"/>	<input type="checkbox"/>	<input type="checkbox"/>
1105 cylinder	<input type="checkbox"/>	<input type="checkbox"/>	<input type="checkbox"/>	<input type="checkbox"/>	<input type="checkbox"/>
1106 boom speed	<input type="checkbox"/>	<input type="checkbox"/>	<input type="checkbox"/>	<input type="checkbox"/>	<input type="checkbox"/>
1107 pressure settings	<input type="checkbox"/>	<input type="checkbox"/>	<input type="checkbox"/>	<input type="checkbox"/>	<input type="checkbox"/>
1108 hydraulic lines	<input type="checkbox"/>	<input type="checkbox"/>	<input type="checkbox"/>	<input type="checkbox"/>	<input type="checkbox"/>
1109 load holding valve (piston side)	<input type="checkbox"/>	<input type="checkbox"/>	<input type="checkbox"/>	<input type="checkbox"/>	<input type="checkbox"/>
1110 load holding valve (rod side)	<input type="checkbox"/>	<input type="checkbox"/>	<input type="checkbox"/>	<input type="checkbox"/>	<input type="checkbox"/>

**1200 joint "D"**

1201 boom	<input type="checkbox"/>	<input type="checkbox"/>	<input type="checkbox"/>	<input type="checkbox"/>	<input type="checkbox"/>
1202 link lever	<input type="checkbox"/>	<input type="checkbox"/>	<input type="checkbox"/>	<input type="checkbox"/>	<input type="checkbox"/>
1203 forcing rod	<input type="checkbox"/>	<input type="checkbox"/>	<input type="checkbox"/>	<input type="checkbox"/>	<input type="checkbox"/>
1204 pin	<input type="checkbox"/>	<input type="checkbox"/>	<input type="checkbox"/>	<input type="checkbox"/>	<input type="checkbox"/>
1205 cylinder	<input type="checkbox"/>	<input type="checkbox"/>	<input type="checkbox"/>	<input type="checkbox"/>	<input type="checkbox"/>
1206 boom speed	<input type="checkbox"/>	<input type="checkbox"/>	<input type="checkbox"/>	<input type="checkbox"/>	<input type="checkbox"/>
1207 pressure settings	<input type="checkbox"/>	<input type="checkbox"/>	<input type="checkbox"/>	<input type="checkbox"/>	<input type="checkbox"/>
1208 hydraulic lines	<input type="checkbox"/>	<input type="checkbox"/>	<input type="checkbox"/>	<input type="checkbox"/>	<input type="checkbox"/>
1209 load holding valve (piston side)	<input type="checkbox"/>	<input type="checkbox"/>	<input type="checkbox"/>	<input type="checkbox"/>	<input type="checkbox"/>
1210 load holding valve (rod side)	<input type="checkbox"/>	<input type="checkbox"/>	<input type="checkbox"/>	<input type="checkbox"/>	<input type="checkbox"/>

**1300 joint „E“**

1301 boom	<input type="checkbox"/>	<input type="checkbox"/>	<input type="checkbox"/>	<input type="checkbox"/>	<input type="checkbox"/>
1302 link lever	<input type="checkbox"/>	<input type="checkbox"/>	<input type="checkbox"/>	<input type="checkbox"/>	<input type="checkbox"/>
1303 forcing rod	<input type="checkbox"/>	<input type="checkbox"/>	<input type="checkbox"/>	<input type="checkbox"/>	<input type="checkbox"/>
1304 pin	<input type="checkbox"/>	<input type="checkbox"/>	<input type="checkbox"/>	<input type="checkbox"/>	<input type="checkbox"/>
1305 cylinder	<input type="checkbox"/>	<input type="checkbox"/>	<input type="checkbox"/>	<input type="checkbox"/>	<input type="checkbox"/>
1306 boom speed	<input type="checkbox"/>	<input type="checkbox"/>	<input type="checkbox"/>	<input type="checkbox"/>	<input type="checkbox"/>
1307 pressure settings	<input type="checkbox"/>	<input type="checkbox"/>	<input type="checkbox"/>	<input type="checkbox"/>	<input type="checkbox"/>
1308 hydraulic lines	<input type="checkbox"/>	<input type="checkbox"/>	<input type="checkbox"/>	<input type="checkbox"/>	<input type="checkbox"/>
1309 load holding valve (piston side)	<input type="checkbox"/>	<input type="checkbox"/>	<input type="checkbox"/>	<input type="checkbox"/>	<input type="checkbox"/>
1310 load holding valve (rod side)	<input type="checkbox"/>	<input type="checkbox"/>	<input type="checkbox"/>	<input type="checkbox"/>	<input type="checkbox"/>

**1400 concrete delivery line**

1401 assembly of delivery line DN	<input type="checkbox"/>	<input type="checkbox"/>	<input type="checkbox"/>	<input type="checkbox"/>	<input type="checkbox"/>
1402 end hose DN+lenght	<input type="checkbox"/>	<input type="checkbox"/>	<input type="checkbox"/>	<input type="checkbox"/>	<input type="checkbox"/>
1403 delivery line DN	<input type="checkbox"/>	<input type="checkbox"/>	<input type="checkbox"/>	<input type="checkbox"/>	<input type="checkbox"/>
1404 rotating joints of - delivery line	<input type="checkbox"/>	<input type="checkbox"/>	<input type="checkbox"/>	<input type="checkbox"/>	<input type="checkbox"/>
1405 locking pin of the coupling	<input type="checkbox"/>	<input type="checkbox"/>	<input type="checkbox"/>	<input type="checkbox"/>	<input type="checkbox"/>

Notes:

--	--

## Inspection report for concrete booms

Inspection report Nr: \_\_\_\_\_ Boom type: \_\_\_\_\_ Machine-Nr: \_\_\_\_\_

**Error code:**

- |                  |                     |                   |                          |
|------------------|---------------------|-------------------|--------------------------|
| 00 no objections | 08 corrosion        | 16 porous         | 24 deformation           |
| 01 cracks        | 09 lacquer failures | 17 burned through | 25 bear movement         |
| 02 broken        | 10 fraying          | 18 not fixed      | 26 lubrication           |
| 03 leaky         | 11 scratched        | 19 clemp          | 27 readability           |
| 04 no function   | 12 bendet           | 20 sawing         | 28 missing components    |
| 05 low lifetime  | 13 noises           | 21 contaminated   | 29 hydraulical           |
| 06 worn out      | 14 vibration        | 22 bad contact    | 30 electrical            |
| 07 dirt          | 15 miscellaneous    | 23 temperature    | 31 reinspection required |

1406 end hose safety device

1407 reducer

1408 gate elbow, elbow 6"

**1500 hydraulic system and hydraulic valves**

1501 Pressure relief valve

1502 pressure settings

1503 hydraulic lines

1504 hand operating-  
(function)

1505 boom control valve

1506 hydraulic pump

**1600 electric equipment**

1601 remote control  
(functions)

1602 emergency stop  
(function)

1603 switch for outrigger  
function

1604 switch for boom  
function

1605 wiring harness

1606 central lubrication

**1700 sticker sets**

1701 safety hints

1702 description

1703 operating

1704 short operating  
instruction

1705 sticker „ don't use  
the boom as crane“

1706 sticker „guideline  
operating with boom-  
and concrete pump“

1707 name plate

1708 sticker „danger  
high voltage“

**Competent inspector:**

Date: \_\_\_\_\_

Name: \_\_\_\_\_

Signature: \_\_\_\_\_  
(stamp)

**Customer:**

Signature: \_\_\_\_\_  
(stamp)

# Inspection report for concrete pump

Inspection report Nr:	Machine-Nr:	Hours of operation:
		Concrete output m <sup>3</sup> :
Company:	Post code:	City:

NL      WV

**Proof – Result of the tests**

without defects	defects	reinspection required	shut down
<input type="checkbox"/>	<input type="checkbox"/>	<input type="checkbox"/>	<input type="checkbox"/>

Reinspection until date: .....

**Error code:**

- |                  |                     |                   |                          |
|------------------|---------------------|-------------------|--------------------------|
| 00 no objections | 08 corrosion        | 16 porous         | 24 deformation           |
| 01 cracks        | 09 lacquer failures | 17 burned through | 25 bear movement         |
| 02 broken        | 10 fraying          | 18 not fixed      | 26 lubrication           |
| 03 leaky         | 11 scratched        | 19 clemp          | 27 readability           |
| 04 no fuction    | 12 bendet           | 20 sawing         | 28 missing components    |
| 05 low livetime  | 13 noises           | 21 contaminated   | 29 hydraulical           |
| 06 worn out      | 14 vibration        | 22 bad contact    | 30 electrical            |
| 07 dirt          | 15 miscellaneous    | 23 temperature    | 31 reinspection required |

**2000 documents**

2001 operating manual   

2002 spare parts list   

**2100 drive assembly**

2101 coupling and flange   

2200 gear box   

2300 hydraulic pump  
(main)   

2400 oil-tank   

2500 drive shaft   

**2700 hydraulic control system**

2701 pressure relief valve   

2702 pressure setting   

2703 hydraulic line   

2704 mechanical operation  
by hand   

2800 oil –cooler   

2900 accumulator   

2901 proofs of the required  
tests according to  
accumulator regulation   

2902 pressure gauge   

Notes:



# Inspection report for concrete pump

Inspection report Nr:		Machine-Nr:																																													
<p>Error code:</p> <table style="width: 100%; border: none;"> <tr> <td style="width: 25%;">00 no objections</td> <td style="width: 25%;">08 corrosion</td> <td style="width: 25%;">16 porous</td> <td style="width: 25%;">24 deformation</td> </tr> <tr> <td>01 cracks</td> <td>09 lacquer failures</td> <td>17 burned through</td> <td>25 bear movement</td> </tr> <tr> <td>02 broken</td> <td>10 fraying</td> <td>18 not fixed</td> <td>26 lubrication</td> </tr> <tr> <td>03 leaky</td> <td>11 scratched</td> <td>19 clomp</td> <td>27 readability</td> </tr> <tr> <td>04 no function</td> <td>12 bendet</td> <td>20 sawing</td> <td>28 missing components</td> </tr> <tr> <td>05 low lifetime</td> <td>13 noises</td> <td>21 contamitated</td> <td>29 hydraulical</td> </tr> <tr> <td>06 worn out</td> <td>14 vibration</td> <td>22 bad contact</td> <td>30 electrical</td> </tr> <tr> <td>07 dirt</td> <td>15 miscellaneous</td> <td>23 temperature</td> <td>31 reinspection required</td> </tr> </table>				00 no objections	08 corrosion	16 porous	24 deformation	01 cracks	09 lacquer failures	17 burned through	25 bear movement	02 broken	10 fraying	18 not fixed	26 lubrication	03 leaky	11 scratched	19 clomp	27 readability	04 no function	12 bendet	20 sawing	28 missing components	05 low lifetime	13 noises	21 contamitated	29 hydraulical	06 worn out	14 vibration	22 bad contact	30 electrical	07 dirt	15 miscellaneous	23 temperature	31 reinspection required												
00 no objections	08 corrosion	16 porous	24 deformation																																												
01 cracks	09 lacquer failures	17 burned through	25 bear movement																																												
02 broken	10 fraying	18 not fixed	26 lubrication																																												
03 leaky	11 scratched	19 clomp	27 readability																																												
04 no function	12 bendet	20 sawing	28 missing components																																												
05 low lifetime	13 noises	21 contamitated	29 hydraulical																																												
06 worn out	14 vibration	22 bad contact	30 electrical																																												
07 dirt	15 miscellaneous	23 temperature	31 reinspection required																																												
<table style="width: 100%; border: none;"> <tr> <td style="width: 80%;">3000 central lubrication</td> <td style="width: 20%; text-align: center;"><input type="checkbox"/><input type="checkbox"/><input type="checkbox"/><input type="checkbox"/><input type="checkbox"/></td> </tr> <tr> <td>3100 hydraulic motor</td> <td style="text-align: center;"><input type="checkbox"/><input type="checkbox"/><input type="checkbox"/><input type="checkbox"/><input type="checkbox"/></td> </tr> <tr> <td>3200 hydraulic lines</td> <td style="text-align: center;"><input type="checkbox"/><input type="checkbox"/><input type="checkbox"/><input type="checkbox"/><input type="checkbox"/></td> </tr> <tr> <td>3300 air compressor</td> <td style="text-align: center;"><input type="checkbox"/><input type="checkbox"/><input type="checkbox"/><input type="checkbox"/><input type="checkbox"/></td> </tr> <tr> <td>3400 control panel</td> <td style="text-align: center;"><input type="checkbox"/><input type="checkbox"/><input type="checkbox"/><input type="checkbox"/><input type="checkbox"/></td> </tr> <tr> <td>3500 concrete pump</td> <td style="text-align: center;"><input type="checkbox"/><input type="checkbox"/><input type="checkbox"/><input type="checkbox"/><input type="checkbox"/></td> </tr> <tr> <td>3700 S-valve</td> <td style="text-align: center;"><input type="checkbox"/><input type="checkbox"/><input type="checkbox"/><input type="checkbox"/><input type="checkbox"/></td> </tr> <tr> <td>3800 hopper</td> <td style="text-align: center;"><input type="checkbox"/><input type="checkbox"/><input type="checkbox"/><input type="checkbox"/><input type="checkbox"/></td> </tr> <tr> <td>4100 sub frame</td> <td style="text-align: center;"><input type="checkbox"/><input type="checkbox"/><input type="checkbox"/><input type="checkbox"/><input type="checkbox"/></td> </tr> <tr> <td>4200 water tank</td> <td style="text-align: center;"><input type="checkbox"/><input type="checkbox"/><input type="checkbox"/><input type="checkbox"/><input type="checkbox"/></td> </tr> <tr> <td>4300 axle</td> <td style="text-align: center;"><input type="checkbox"/><input type="checkbox"/><input type="checkbox"/><input type="checkbox"/><input type="checkbox"/></td> </tr> <tr> <td>4400 water pump</td> <td style="text-align: center;"><input type="checkbox"/><input type="checkbox"/><input type="checkbox"/><input type="checkbox"/><input type="checkbox"/></td> </tr> <tr> <td>4500 vibrator</td> <td style="text-align: center;"><input type="checkbox"/><input type="checkbox"/><input type="checkbox"/><input type="checkbox"/><input type="checkbox"/></td> </tr> </table>	3000 central lubrication	<input type="checkbox"/> <input type="checkbox"/> <input type="checkbox"/> <input type="checkbox"/> <input type="checkbox"/>	3100 hydraulic motor	<input type="checkbox"/> <input type="checkbox"/> <input type="checkbox"/> <input type="checkbox"/> <input type="checkbox"/>	3200 hydraulic lines	<input type="checkbox"/> <input type="checkbox"/> <input type="checkbox"/> <input type="checkbox"/> <input type="checkbox"/>	3300 air compressor	<input type="checkbox"/> <input type="checkbox"/> <input type="checkbox"/> <input type="checkbox"/> <input type="checkbox"/>	3400 control panel	<input type="checkbox"/> <input type="checkbox"/> <input type="checkbox"/> <input type="checkbox"/> <input type="checkbox"/>	3500 concrete pump	<input type="checkbox"/> <input type="checkbox"/> <input type="checkbox"/> <input type="checkbox"/> <input type="checkbox"/>	3700 S-valve	<input type="checkbox"/> <input type="checkbox"/> <input type="checkbox"/> <input type="checkbox"/> <input type="checkbox"/>	3800 hopper	<input type="checkbox"/> <input type="checkbox"/> <input type="checkbox"/> <input type="checkbox"/> <input type="checkbox"/>	4100 sub frame	<input type="checkbox"/> <input type="checkbox"/> <input type="checkbox"/> <input type="checkbox"/> <input type="checkbox"/>	4200 water tank	<input type="checkbox"/> <input type="checkbox"/> <input type="checkbox"/> <input type="checkbox"/> <input type="checkbox"/>	4300 axle	<input type="checkbox"/> <input type="checkbox"/> <input type="checkbox"/> <input type="checkbox"/> <input type="checkbox"/>	4400 water pump	<input type="checkbox"/> <input type="checkbox"/> <input type="checkbox"/> <input type="checkbox"/> <input type="checkbox"/>	4500 vibrator	<input type="checkbox"/> <input type="checkbox"/> <input type="checkbox"/> <input type="checkbox"/> <input type="checkbox"/>	<p><b>4600 safety guards, equipment</b></p> <table style="width: 100%; border: none;"> <tr> <td style="width: 80%;">4601 stair</td> <td style="width: 20%; text-align: center;"><input type="checkbox"/><input type="checkbox"/><input type="checkbox"/><input type="checkbox"/><input type="checkbox"/></td> </tr> <tr> <td>4602 safety for stair</td> <td style="text-align: center;"><input type="checkbox"/><input type="checkbox"/><input type="checkbox"/><input type="checkbox"/><input type="checkbox"/></td> </tr> <tr> <td>4603 handrail</td> <td style="text-align: center;"><input type="checkbox"/><input type="checkbox"/><input type="checkbox"/><input type="checkbox"/><input type="checkbox"/></td> </tr> <tr> <td>4604 hopper grid (fixing device)</td> <td style="text-align: center;"><input type="checkbox"/><input type="checkbox"/><input type="checkbox"/><input type="checkbox"/><input type="checkbox"/></td> </tr> <tr> <td>4606 distance of grid rods</td> <td style="text-align: center;"><input type="checkbox"/><input type="checkbox"/><input type="checkbox"/><input type="checkbox"/><input type="checkbox"/></td> </tr> <tr> <td>4607 distance from grid to agitator</td> <td style="text-align: center;"><input type="checkbox"/><input type="checkbox"/><input type="checkbox"/><input type="checkbox"/><input type="checkbox"/></td> </tr> <tr> <td>4609 agitator have to stop if grid is open</td> <td style="text-align: center;"><input type="checkbox"/><input type="checkbox"/><input type="checkbox"/><input type="checkbox"/><input type="checkbox"/></td> </tr> <tr> <td>4610 accumulator have to dump if grid is open</td> <td style="text-align: center;"><input type="checkbox"/><input type="checkbox"/><input type="checkbox"/><input type="checkbox"/><input type="checkbox"/></td> </tr> <tr> <td>4612 cleaning flap hopper</td> <td style="text-align: center;"><input type="checkbox"/><input type="checkbox"/><input type="checkbox"/><input type="checkbox"/><input type="checkbox"/></td> </tr> <tr> <td>4613 safety grid into water box</td> <td style="text-align: center;"><input type="checkbox"/><input type="checkbox"/><input type="checkbox"/><input type="checkbox"/><input type="checkbox"/></td> </tr> </table> <p>Notes:</p> <div style="border: 1px solid black; height: 100px; margin-top: 5px;"></div>	4601 stair	<input type="checkbox"/> <input type="checkbox"/> <input type="checkbox"/> <input type="checkbox"/> <input type="checkbox"/>	4602 safety for stair	<input type="checkbox"/> <input type="checkbox"/> <input type="checkbox"/> <input type="checkbox"/> <input type="checkbox"/>	4603 handrail	<input type="checkbox"/> <input type="checkbox"/> <input type="checkbox"/> <input type="checkbox"/> <input type="checkbox"/>	4604 hopper grid (fixing device)	<input type="checkbox"/> <input type="checkbox"/> <input type="checkbox"/> <input type="checkbox"/> <input type="checkbox"/>	4606 distance of grid rods	<input type="checkbox"/> <input type="checkbox"/> <input type="checkbox"/> <input type="checkbox"/> <input type="checkbox"/>	4607 distance from grid to agitator	<input type="checkbox"/> <input type="checkbox"/> <input type="checkbox"/> <input type="checkbox"/> <input type="checkbox"/>	4609 agitator have to stop if grid is open	<input type="checkbox"/> <input type="checkbox"/> <input type="checkbox"/> <input type="checkbox"/> <input type="checkbox"/>	4610 accumulator have to dump if grid is open	<input type="checkbox"/> <input type="checkbox"/> <input type="checkbox"/> <input type="checkbox"/> <input type="checkbox"/>	4612 cleaning flap hopper	<input type="checkbox"/> <input type="checkbox"/> <input type="checkbox"/> <input type="checkbox"/> <input type="checkbox"/>	4613 safety grid into water box	<input type="checkbox"/> <input type="checkbox"/> <input type="checkbox"/> <input type="checkbox"/> <input type="checkbox"/>
3000 central lubrication	<input type="checkbox"/> <input type="checkbox"/> <input type="checkbox"/> <input type="checkbox"/> <input type="checkbox"/>																																														
3100 hydraulic motor	<input type="checkbox"/> <input type="checkbox"/> <input type="checkbox"/> <input type="checkbox"/> <input type="checkbox"/>																																														
3200 hydraulic lines	<input type="checkbox"/> <input type="checkbox"/> <input type="checkbox"/> <input type="checkbox"/> <input type="checkbox"/>																																														
3300 air compressor	<input type="checkbox"/> <input type="checkbox"/> <input type="checkbox"/> <input type="checkbox"/> <input type="checkbox"/>																																														
3400 control panel	<input type="checkbox"/> <input type="checkbox"/> <input type="checkbox"/> <input type="checkbox"/> <input type="checkbox"/>																																														
3500 concrete pump	<input type="checkbox"/> <input type="checkbox"/> <input type="checkbox"/> <input type="checkbox"/> <input type="checkbox"/>																																														
3700 S-valve	<input type="checkbox"/> <input type="checkbox"/> <input type="checkbox"/> <input type="checkbox"/> <input type="checkbox"/>																																														
3800 hopper	<input type="checkbox"/> <input type="checkbox"/> <input type="checkbox"/> <input type="checkbox"/> <input type="checkbox"/>																																														
4100 sub frame	<input type="checkbox"/> <input type="checkbox"/> <input type="checkbox"/> <input type="checkbox"/> <input type="checkbox"/>																																														
4200 water tank	<input type="checkbox"/> <input type="checkbox"/> <input type="checkbox"/> <input type="checkbox"/> <input type="checkbox"/>																																														
4300 axle	<input type="checkbox"/> <input type="checkbox"/> <input type="checkbox"/> <input type="checkbox"/> <input type="checkbox"/>																																														
4400 water pump	<input type="checkbox"/> <input type="checkbox"/> <input type="checkbox"/> <input type="checkbox"/> <input type="checkbox"/>																																														
4500 vibrator	<input type="checkbox"/> <input type="checkbox"/> <input type="checkbox"/> <input type="checkbox"/> <input type="checkbox"/>																																														
4601 stair	<input type="checkbox"/> <input type="checkbox"/> <input type="checkbox"/> <input type="checkbox"/> <input type="checkbox"/>																																														
4602 safety for stair	<input type="checkbox"/> <input type="checkbox"/> <input type="checkbox"/> <input type="checkbox"/> <input type="checkbox"/>																																														
4603 handrail	<input type="checkbox"/> <input type="checkbox"/> <input type="checkbox"/> <input type="checkbox"/> <input type="checkbox"/>																																														
4604 hopper grid (fixing device)	<input type="checkbox"/> <input type="checkbox"/> <input type="checkbox"/> <input type="checkbox"/> <input type="checkbox"/>																																														
4606 distance of grid rods	<input type="checkbox"/> <input type="checkbox"/> <input type="checkbox"/> <input type="checkbox"/> <input type="checkbox"/>																																														
4607 distance from grid to agitator	<input type="checkbox"/> <input type="checkbox"/> <input type="checkbox"/> <input type="checkbox"/> <input type="checkbox"/>																																														
4609 agitator have to stop if grid is open	<input type="checkbox"/> <input type="checkbox"/> <input type="checkbox"/> <input type="checkbox"/> <input type="checkbox"/>																																														
4610 accumulator have to dump if grid is open	<input type="checkbox"/> <input type="checkbox"/> <input type="checkbox"/> <input type="checkbox"/> <input type="checkbox"/>																																														
4612 cleaning flap hopper	<input type="checkbox"/> <input type="checkbox"/> <input type="checkbox"/> <input type="checkbox"/> <input type="checkbox"/>																																														
4613 safety grid into water box	<input type="checkbox"/> <input type="checkbox"/> <input type="checkbox"/> <input type="checkbox"/> <input type="checkbox"/>																																														

# Inspection report for concrete pump

Inspection report Nr: \_\_\_\_\_ Machine-Nr: \_\_\_\_\_

**Error code:**

- |                  |                     |                   |                          |
|------------------|---------------------|-------------------|--------------------------|
| 00 no objections | 08 corrosion        | 16 porous         | 24 deformation           |
| 01 cracks        | 09 lacquer failures | 17 burned through | 25 bear movement         |
| 02 broken        | 10 fraying          | 18 not fixed      | 26 lubrication           |
| 03 leaky         | 11 scratched        | 19 clemp          | 27 readability           |
| 04 no function   | 12 bendet           | 20 sawing         | 28 missing components    |
| 05 low lifetime  | 13 noises           | 21 contamitated   | 29 hydraulical           |
| 06 worn out      | 14 vibration        | 22 bad contact    | 30 electrical            |
| 07 dirt          | 15 miscellaneous    | 23 temperature    | 31 reinspection required |

4614 cover for rotating wave

4616 cover for chains

4617 cover for shift cylinder

4618 cover for moving parts

4619 cover for the exhaust pipe

**4700 electrical system**

4701 function of actuator component

4702 emergency stop function

4703 ground connections

4704 cables and wiring harness

4705 temperature switch

**4800 outrigger - system**

4801 transportation lock

4802 locking device

4803 backing plate

4804 jack cylinder connections

4805 pressure adjustment of jack cylinder

**4900 miscellaneous**

4901 additional assembled part from operator

4902 changes through operator

**Competent inspector:**

Date: .....

Name: .....

Signature: .....  
(stamp)

**Customer:**

Signature: .....  
(stamp)

**This test report is filed into the test book**

# Inspection report for concrete booms

Inspection report -Nr:	Machine-Nr:	Hours of operation:
		Concrete output m <sup>3</sup> :
Company:	Post code:	City:
Boom Type:	Boom Nr.:	NL                      WV

**Proof - Result of the Tests**

without defects	defects	reinspection required	shut down
<input type="checkbox"/>	<input type="checkbox"/>	<input type="checkbox"/>	<input type="checkbox"/>

Reinspection until date: .....

**Error code:**

- |                  |                     |                   |                          |
|------------------|---------------------|-------------------|--------------------------|
| 00 no objections | 08 corrosion        | 16 porous         | 24 deformation           |
| 01 cracks        | 09 lacquer failures | 17 burned through | 25 bear movement         |
| 02 broken        | 10 fraying          | 18 not fixed      | 26 lubrication           |
| 03 leaky         | 11 scratched        | 19 clomp          | 27 readability           |
| 04 no function   | 12 bendet           | 20 sawing         | 28 missing components    |
| 05 low lifetime  | 13 noises           | 21 contaminated   | 29 hydraulical           |
| 06 worn out      | 14 vibration        | 22 bad contact    | 30 electrical            |
| 07 dirt          | 15 miscellaneous    | 23 temperature    | 31 reinspection required |

<p><b>100 documents</b></p> <p>101 instruction manual    <input type="checkbox"/> <input type="checkbox"/> <input type="checkbox"/> <input type="checkbox"/> <input type="checkbox"/></p> <p>102 spare parts list      <input type="checkbox"/> <input type="checkbox"/> <input type="checkbox"/> <input type="checkbox"/> <input type="checkbox"/></p> <p><b>200 sub frame</b></p> <p>201 frame connection cpl.   <input type="checkbox"/> <input type="checkbox"/> <input type="checkbox"/> <input type="checkbox"/> <input type="checkbox"/></p> <p><b>300 outrigger front R+L</b></p> <p>301 transportation safety device   <input type="checkbox"/> <input type="checkbox"/> <input type="checkbox"/> <input type="checkbox"/> <input type="checkbox"/></p> <p>302 outrigger                    <input type="checkbox"/> <input type="checkbox"/> <input type="checkbox"/> <input type="checkbox"/> <input type="checkbox"/></p> <p>303 extension box            <input type="checkbox"/> <input type="checkbox"/> <input type="checkbox"/> <input type="checkbox"/> <input type="checkbox"/></p> <p>304 locking device            <input type="checkbox"/> <input type="checkbox"/> <input type="checkbox"/> <input type="checkbox"/> <input type="checkbox"/></p> <p>305 slewing bearing         <input type="checkbox"/> <input type="checkbox"/> <input type="checkbox"/> <input type="checkbox"/> <input type="checkbox"/></p> <p>306 turn locking device      <input type="checkbox"/> <input type="checkbox"/> <input type="checkbox"/> <input type="checkbox"/> <input type="checkbox"/></p> <p>307 support safeguard      <input type="checkbox"/> <input type="checkbox"/> <input type="checkbox"/> <input type="checkbox"/> <input type="checkbox"/></p> <p>308 support plate            <input type="checkbox"/> <input type="checkbox"/> <input type="checkbox"/> <input type="checkbox"/> <input type="checkbox"/></p> <p>309 fixing of jack cylinder   <input type="checkbox"/> <input type="checkbox"/> <input type="checkbox"/> <input type="checkbox"/> <input type="checkbox"/></p> <p>310 jack cylinder            <input type="checkbox"/> <input type="checkbox"/> <input type="checkbox"/> <input type="checkbox"/> <input type="checkbox"/></p>	<p>311 swing cylinder           <input type="checkbox"/> <input type="checkbox"/> <input type="checkbox"/> <input type="checkbox"/> <input type="checkbox"/></p> <p>312 telescopic-cylinder    <input type="checkbox"/> <input type="checkbox"/> <input type="checkbox"/> <input type="checkbox"/> <input type="checkbox"/></p> <p>313 pressure adjustment   <input type="checkbox"/> <input type="checkbox"/> <input type="checkbox"/> <input type="checkbox"/> <input type="checkbox"/></p> <p><b>400 outrigger rear L+R</b></p> <p>401 transportation safety device   <input type="checkbox"/> <input type="checkbox"/> <input type="checkbox"/> <input type="checkbox"/> <input type="checkbox"/></p> <p>402 outrigger                    <input type="checkbox"/> <input type="checkbox"/> <input type="checkbox"/> <input type="checkbox"/> <input type="checkbox"/></p> <p>403 extension box            <input type="checkbox"/> <input type="checkbox"/> <input type="checkbox"/> <input type="checkbox"/> <input type="checkbox"/></p> <p>405 locking device            <input type="checkbox"/> <input type="checkbox"/> <input type="checkbox"/> <input type="checkbox"/> <input type="checkbox"/></p> <p>Notes:</p> <hr/> <hr/> <hr/> <hr/> <hr/>
--	---

# Inspection report for concrete booms

Inspection report Nr: \_\_\_\_\_ Boom type: \_\_\_\_\_ Machine-Nr: \_\_\_\_\_

- |                  |                     |                   |                          |
|------------------|---------------------|-------------------|--------------------------|
| Error code:      |                     |                   |                          |
| 00 no objections | 08 corrosion        | 16 porous         | 24 deformation           |
| 01 cracks        | 09 lacquer failures | 17 burned through | 25 bear movement         |
| 02 broken        | 10 fraying          | 18 not fixed      | 26 lubrication           |
| 03 leaky         | 11 scratched        | 19 clomp          | 27 readability           |
| 04 no function   | 12 bendet           | 20 sawing         | 28 missing components    |
| 05 low lifetime  | 13 noises           | 21 contaminated   | 29 hydraulical           |
| 06 worn out      | 14 vibration        | 22 bad contact    | 30 electrical            |
| 07 dirt          | 15 miscellaneous    | 23 temperature    | 31 reinspection required |

<table border="0" style="width: 100%;"> <tr> <td style="width: 30%;">406 slewing bearing</td> <td style="width: 20%;"><input type="checkbox"/></td><td><input type="checkbox"/></td><td><input type="checkbox"/></td><td><input type="checkbox"/></td><td><input type="checkbox"/></td> </tr> <tr> <td>407 turn locking device</td> <td><input type="checkbox"/></td><td><input type="checkbox"/></td><td><input type="checkbox"/></td><td><input type="checkbox"/></td><td><input type="checkbox"/></td> </tr> <tr> <td>408 support safeguard</td> <td><input type="checkbox"/></td><td><input type="checkbox"/></td><td><input type="checkbox"/></td><td><input type="checkbox"/></td><td><input type="checkbox"/></td> </tr> <tr> <td>409 support plate</td> <td><input type="checkbox"/></td><td><input type="checkbox"/></td><td><input type="checkbox"/></td><td><input type="checkbox"/></td><td><input type="checkbox"/></td> </tr> <tr> <td>410 fixing of jack cylinder</td> <td><input type="checkbox"/></td><td><input type="checkbox"/></td><td><input type="checkbox"/></td><td><input type="checkbox"/></td><td><input type="checkbox"/></td> </tr> <tr> <td>411 jack cylinder</td> <td><input type="checkbox"/></td><td><input type="checkbox"/></td><td><input type="checkbox"/></td><td><input type="checkbox"/></td><td><input type="checkbox"/></td> </tr> <tr> <td>412 swing cylinder</td> <td><input type="checkbox"/></td><td><input type="checkbox"/></td><td><input type="checkbox"/></td><td><input type="checkbox"/></td><td><input type="checkbox"/></td> </tr> <tr> <td>413 telescopic cylinder</td> <td><input type="checkbox"/></td><td><input type="checkbox"/></td><td><input type="checkbox"/></td><td><input type="checkbox"/></td><td><input type="checkbox"/></td> </tr> <tr> <td colspan="6"> </td> </tr> <tr> <td><b>500 pedestal</b></td> <td colspan="5"></td> </tr> <tr> <td>501 pedestal mounting</td> <td><input type="checkbox"/></td><td><input type="checkbox"/></td><td><input type="checkbox"/></td><td><input type="checkbox"/></td><td><input type="checkbox"/></td> </tr> <tr> <td>502 sub frame</td> <td><input type="checkbox"/></td><td><input type="checkbox"/></td><td><input type="checkbox"/></td><td><input type="checkbox"/></td><td><input type="checkbox"/></td> </tr> <tr> <td>503 truck frame</td> <td><input type="checkbox"/></td><td><input type="checkbox"/></td><td><input type="checkbox"/></td><td><input type="checkbox"/></td><td><input type="checkbox"/></td> </tr> <tr> <td>504 pedestal (structure)</td> <td><input type="checkbox"/></td><td><input type="checkbox"/></td><td><input type="checkbox"/></td><td><input type="checkbox"/></td><td><input type="checkbox"/></td> </tr> <tr> <td>505 boom valve without leaking</td> <td><input type="checkbox"/></td><td><input type="checkbox"/></td><td><input type="checkbox"/></td><td><input type="checkbox"/></td><td><input type="checkbox"/></td> </tr> <tr> <td>506 boom rest</td> <td><input type="checkbox"/></td><td><input type="checkbox"/></td><td><input type="checkbox"/></td><td><input type="checkbox"/></td><td><input type="checkbox"/></td> </tr> <tr> <td>507 transportation safety device</td> <td><input type="checkbox"/></td><td><input type="checkbox"/></td><td><input type="checkbox"/></td><td><input type="checkbox"/></td><td><input type="checkbox"/></td> </tr> <tr> <td>508 hydraulic line</td> <td><input type="checkbox"/></td><td><input type="checkbox"/></td><td><input type="checkbox"/></td><td><input type="checkbox"/></td><td><input type="checkbox"/></td> </tr> <tr> <td colspan="6"> </td> </tr> <tr> <td><b>600 slewing head with ball pivot</b></td> <td colspan="5"></td> </tr> <tr> <td>601 slewing head</td> <td><input type="checkbox"/></td><td><input type="checkbox"/></td><td><input type="checkbox"/></td><td><input type="checkbox"/></td><td><input type="checkbox"/></td> </tr> <tr> <td>602 ball pivot ring</td> <td><input type="checkbox"/></td><td><input type="checkbox"/></td><td><input type="checkbox"/></td><td><input type="checkbox"/></td><td><input type="checkbox"/></td> </tr> <tr> <td>603 mounting ball pivot ring</td> <td><input type="checkbox"/></td><td><input type="checkbox"/></td><td><input type="checkbox"/></td><td><input type="checkbox"/></td><td><input type="checkbox"/></td> </tr> <tr> <td>604 drive pinion</td> <td><input type="checkbox"/></td><td><input type="checkbox"/></td><td><input type="checkbox"/></td><td><input type="checkbox"/></td><td><input type="checkbox"/></td> </tr> </table>	406 slewing bearing	<input type="checkbox"/>	<input type="checkbox"/>	<input type="checkbox"/>	<input type="checkbox"/>	<input type="checkbox"/>	407 turn locking device	<input type="checkbox"/>	<input type="checkbox"/>	<input type="checkbox"/>	<input type="checkbox"/>	<input type="checkbox"/>	408 support safeguard	<input type="checkbox"/>	<input type="checkbox"/>	<input type="checkbox"/>	<input type="checkbox"/>	<input type="checkbox"/>	409 support plate	<input type="checkbox"/>	<input type="checkbox"/>	<input type="checkbox"/>	<input type="checkbox"/>	<input type="checkbox"/>	410 fixing of jack cylinder	<input type="checkbox"/>	<input type="checkbox"/>	<input type="checkbox"/>	<input type="checkbox"/>	<input type="checkbox"/>	411 jack cylinder	<input type="checkbox"/>	<input type="checkbox"/>	<input type="checkbox"/>	<input type="checkbox"/>	<input type="checkbox"/>	412 swing cylinder	<input type="checkbox"/>	<input type="checkbox"/>	<input type="checkbox"/>	<input type="checkbox"/>	<input type="checkbox"/>	413 telescopic cylinder	<input type="checkbox"/>	<input type="checkbox"/>	<input type="checkbox"/>	<input type="checkbox"/>	<input type="checkbox"/>	 						<b>500 pedestal</b>						501 pedestal mounting	<input type="checkbox"/>	<input type="checkbox"/>	<input type="checkbox"/>	<input type="checkbox"/>	<input type="checkbox"/>	502 sub frame	<input type="checkbox"/>	<input type="checkbox"/>	<input type="checkbox"/>	<input type="checkbox"/>	<input type="checkbox"/>	503 truck frame	<input type="checkbox"/>	<input type="checkbox"/>	<input type="checkbox"/>	<input type="checkbox"/>	<input type="checkbox"/>	504 pedestal (structure)	<input type="checkbox"/>	<input type="checkbox"/>	<input type="checkbox"/>	<input type="checkbox"/>	<input type="checkbox"/>	505 boom valve without leaking	<input type="checkbox"/>	<input type="checkbox"/>	<input type="checkbox"/>	<input type="checkbox"/>	<input type="checkbox"/>	506 boom rest	<input type="checkbox"/>	<input type="checkbox"/>	<input type="checkbox"/>	<input type="checkbox"/>	<input type="checkbox"/>	507 transportation safety device	<input type="checkbox"/>	<input type="checkbox"/>	<input type="checkbox"/>	<input type="checkbox"/>	<input type="checkbox"/>	508 hydraulic line	<input type="checkbox"/>	<input type="checkbox"/>	<input type="checkbox"/>	<input type="checkbox"/>	<input type="checkbox"/>	 						<b>600 slewing head with ball pivot</b>						601 slewing head	<input type="checkbox"/>	<input type="checkbox"/>	<input type="checkbox"/>	<input type="checkbox"/>	<input type="checkbox"/>	602 ball pivot ring	<input type="checkbox"/>	<input type="checkbox"/>	<input type="checkbox"/>	<input type="checkbox"/>	<input type="checkbox"/>	603 mounting ball pivot ring	<input type="checkbox"/>	<input type="checkbox"/>	<input type="checkbox"/>	<input type="checkbox"/>	<input type="checkbox"/>	604 drive pinion	<input type="checkbox"/>	<input type="checkbox"/>	<input type="checkbox"/>	<input type="checkbox"/>	<input type="checkbox"/>	<table border="0" style="width: 100%;"> <tr> <td style="width: 30%;">605 slewing drive mounting</td> <td style="width: 20%;"><input type="checkbox"/></td><td><input type="checkbox"/></td><td><input type="checkbox"/></td><td><input type="checkbox"/></td><td><input type="checkbox"/></td> </tr> <tr> <td>606 slewing stop device</td> <td><input type="checkbox"/></td><td><input type="checkbox"/></td><td><input type="checkbox"/></td><td><input type="checkbox"/></td><td><input type="checkbox"/></td> </tr> <tr> <td>607 slewing drive (tooth backlash)</td> <td><input type="checkbox"/></td><td><input type="checkbox"/></td><td><input type="checkbox"/></td><td><input type="checkbox"/></td><td><input type="checkbox"/></td> </tr> <tr> <td>608 slewing drive</td> <td><input type="checkbox"/></td><td><input type="checkbox"/></td><td><input type="checkbox"/></td><td><input type="checkbox"/></td><td><input type="checkbox"/></td> </tr> <tr> <td>609 brake function</td> <td><input type="checkbox"/></td><td><input type="checkbox"/></td><td><input type="checkbox"/></td><td><input type="checkbox"/></td><td><input type="checkbox"/></td> </tr> <tr> <td>610 speed</td> <td><input type="checkbox"/></td><td><input type="checkbox"/></td><td><input type="checkbox"/></td><td><input type="checkbox"/></td><td><input type="checkbox"/></td> </tr> <tr> <td>611 pressure setting</td> <td><input type="checkbox"/></td><td><input type="checkbox"/></td><td><input type="checkbox"/></td><td><input type="checkbox"/></td><td><input type="checkbox"/></td> </tr> <tr> <td>612 hydraulic lines</td> <td><input type="checkbox"/></td><td><input type="checkbox"/></td><td><input type="checkbox"/></td><td><input type="checkbox"/></td><td><input type="checkbox"/></td> </tr> <tr> <td colspan="6"> </td> </tr> <tr> <td><b>700 slewing head with slewing column</b></td> <td colspan="5"></td> </tr> <tr> <td>701 slewing head</td> <td><input type="checkbox"/></td><td><input type="checkbox"/></td><td><input type="checkbox"/></td><td><input type="checkbox"/></td><td><input type="checkbox"/></td> </tr> <tr> <td>702 slewing column bearing</td> <td><input type="checkbox"/></td><td><input type="checkbox"/></td><td><input type="checkbox"/></td><td><input type="checkbox"/></td><td><input type="checkbox"/></td> </tr> <tr> <td>703 slewing drive (tooth backlash)</td> <td><input type="checkbox"/></td><td><input type="checkbox"/></td><td><input type="checkbox"/></td><td><input type="checkbox"/></td><td><input type="checkbox"/></td> </tr> <tr> <td>704 speed</td> <td><input type="checkbox"/></td><td><input type="checkbox"/></td><td><input type="checkbox"/></td><td><input type="checkbox"/></td><td><input type="checkbox"/></td> </tr> <tr> <td>705 pressure settings</td> <td><input type="checkbox"/></td><td><input type="checkbox"/></td><td><input type="checkbox"/></td><td><input type="checkbox"/></td><td><input type="checkbox"/></td> </tr> <tr> <td>706 hydraulic lines</td> <td><input type="checkbox"/></td><td><input type="checkbox"/></td><td><input type="checkbox"/></td><td><input type="checkbox"/></td><td><input type="checkbox"/></td> </tr> <tr> <td>707 swivel cylinder</td> <td><input type="checkbox"/></td><td><input type="checkbox"/></td><td><input type="checkbox"/></td><td><input type="checkbox"/></td><td><input type="checkbox"/></td> </tr> </table>	605 slewing drive mounting	<input type="checkbox"/>	<input type="checkbox"/>	<input type="checkbox"/>	<input type="checkbox"/>	<input type="checkbox"/>	606 slewing stop device	<input type="checkbox"/>	<input type="checkbox"/>	<input type="checkbox"/>	<input type="checkbox"/>	<input type="checkbox"/>	607 slewing drive (tooth backlash)	<input type="checkbox"/>	<input type="checkbox"/>	<input type="checkbox"/>	<input type="checkbox"/>	<input type="checkbox"/>	608 slewing drive	<input type="checkbox"/>	<input type="checkbox"/>	<input type="checkbox"/>	<input type="checkbox"/>	<input type="checkbox"/>	609 brake function	<input type="checkbox"/>	<input type="checkbox"/>	<input type="checkbox"/>	<input type="checkbox"/>	<input type="checkbox"/>	610 speed	<input type="checkbox"/>	<input type="checkbox"/>	<input type="checkbox"/>	<input type="checkbox"/>	<input type="checkbox"/>	611 pressure setting	<input type="checkbox"/>	<input type="checkbox"/>	<input type="checkbox"/>	<input type="checkbox"/>	<input type="checkbox"/>	612 hydraulic lines	<input type="checkbox"/>	<input type="checkbox"/>	<input type="checkbox"/>	<input type="checkbox"/>	<input type="checkbox"/>	 						<b>700 slewing head with slewing column</b>						701 slewing head	<input type="checkbox"/>	<input type="checkbox"/>	<input type="checkbox"/>	<input type="checkbox"/>	<input type="checkbox"/>	702 slewing column bearing	<input type="checkbox"/>	<input type="checkbox"/>	<input type="checkbox"/>	<input type="checkbox"/>	<input type="checkbox"/>	703 slewing drive (tooth backlash)	<input type="checkbox"/>	<input type="checkbox"/>	<input type="checkbox"/>	<input type="checkbox"/>	<input type="checkbox"/>	704 speed	<input type="checkbox"/>	<input type="checkbox"/>	<input type="checkbox"/>	<input type="checkbox"/>	<input type="checkbox"/>	705 pressure settings	<input type="checkbox"/>	<input type="checkbox"/>	<input type="checkbox"/>	<input type="checkbox"/>	<input type="checkbox"/>	706 hydraulic lines	<input type="checkbox"/>	<input type="checkbox"/>	<input type="checkbox"/>	<input type="checkbox"/>	<input type="checkbox"/>	707 swivel cylinder	<input type="checkbox"/>	<input type="checkbox"/>	<input type="checkbox"/>	<input type="checkbox"/>	<input type="checkbox"/>
406 slewing bearing	<input type="checkbox"/>	<input type="checkbox"/>	<input type="checkbox"/>	<input type="checkbox"/>	<input type="checkbox"/>																																																																																																																																																																																																																																																		
407 turn locking device	<input type="checkbox"/>	<input type="checkbox"/>	<input type="checkbox"/>	<input type="checkbox"/>	<input type="checkbox"/>																																																																																																																																																																																																																																																		
408 support safeguard	<input type="checkbox"/>	<input type="checkbox"/>	<input type="checkbox"/>	<input type="checkbox"/>	<input type="checkbox"/>																																																																																																																																																																																																																																																		
409 support plate	<input type="checkbox"/>	<input type="checkbox"/>	<input type="checkbox"/>	<input type="checkbox"/>	<input type="checkbox"/>																																																																																																																																																																																																																																																		
410 fixing of jack cylinder	<input type="checkbox"/>	<input type="checkbox"/>	<input type="checkbox"/>	<input type="checkbox"/>	<input type="checkbox"/>																																																																																																																																																																																																																																																		
411 jack cylinder	<input type="checkbox"/>	<input type="checkbox"/>	<input type="checkbox"/>	<input type="checkbox"/>	<input type="checkbox"/>																																																																																																																																																																																																																																																		
412 swing cylinder	<input type="checkbox"/>	<input type="checkbox"/>	<input type="checkbox"/>	<input type="checkbox"/>	<input type="checkbox"/>																																																																																																																																																																																																																																																		
413 telescopic cylinder	<input type="checkbox"/>	<input type="checkbox"/>	<input type="checkbox"/>	<input type="checkbox"/>	<input type="checkbox"/>																																																																																																																																																																																																																																																		
<b>500 pedestal</b>																																																																																																																																																																																																																																																							
501 pedestal mounting	<input type="checkbox"/>	<input type="checkbox"/>	<input type="checkbox"/>	<input type="checkbox"/>	<input type="checkbox"/>																																																																																																																																																																																																																																																		
502 sub frame	<input type="checkbox"/>	<input type="checkbox"/>	<input type="checkbox"/>	<input type="checkbox"/>	<input type="checkbox"/>																																																																																																																																																																																																																																																		
503 truck frame	<input type="checkbox"/>	<input type="checkbox"/>	<input type="checkbox"/>	<input type="checkbox"/>	<input type="checkbox"/>																																																																																																																																																																																																																																																		
504 pedestal (structure)	<input type="checkbox"/>	<input type="checkbox"/>	<input type="checkbox"/>	<input type="checkbox"/>	<input type="checkbox"/>																																																																																																																																																																																																																																																		
505 boom valve without leaking	<input type="checkbox"/>	<input type="checkbox"/>	<input type="checkbox"/>	<input type="checkbox"/>	<input type="checkbox"/>																																																																																																																																																																																																																																																		
506 boom rest	<input type="checkbox"/>	<input type="checkbox"/>	<input type="checkbox"/>	<input type="checkbox"/>	<input type="checkbox"/>																																																																																																																																																																																																																																																		
507 transportation safety device	<input type="checkbox"/>	<input type="checkbox"/>	<input type="checkbox"/>	<input type="checkbox"/>	<input type="checkbox"/>																																																																																																																																																																																																																																																		
508 hydraulic line	<input type="checkbox"/>	<input type="checkbox"/>	<input type="checkbox"/>	<input type="checkbox"/>	<input type="checkbox"/>																																																																																																																																																																																																																																																		
<b>600 slewing head with ball pivot</b>																																																																																																																																																																																																																																																							
601 slewing head	<input type="checkbox"/>	<input type="checkbox"/>	<input type="checkbox"/>	<input type="checkbox"/>	<input type="checkbox"/>																																																																																																																																																																																																																																																		
602 ball pivot ring	<input type="checkbox"/>	<input type="checkbox"/>	<input type="checkbox"/>	<input type="checkbox"/>	<input type="checkbox"/>																																																																																																																																																																																																																																																		
603 mounting ball pivot ring	<input type="checkbox"/>	<input type="checkbox"/>	<input type="checkbox"/>	<input type="checkbox"/>	<input type="checkbox"/>																																																																																																																																																																																																																																																		
604 drive pinion	<input type="checkbox"/>	<input type="checkbox"/>	<input type="checkbox"/>	<input type="checkbox"/>	<input type="checkbox"/>																																																																																																																																																																																																																																																		
605 slewing drive mounting	<input type="checkbox"/>	<input type="checkbox"/>	<input type="checkbox"/>	<input type="checkbox"/>	<input type="checkbox"/>																																																																																																																																																																																																																																																		
606 slewing stop device	<input type="checkbox"/>	<input type="checkbox"/>	<input type="checkbox"/>	<input type="checkbox"/>	<input type="checkbox"/>																																																																																																																																																																																																																																																		
607 slewing drive (tooth backlash)	<input type="checkbox"/>	<input type="checkbox"/>	<input type="checkbox"/>	<input type="checkbox"/>	<input type="checkbox"/>																																																																																																																																																																																																																																																		
608 slewing drive	<input type="checkbox"/>	<input type="checkbox"/>	<input type="checkbox"/>	<input type="checkbox"/>	<input type="checkbox"/>																																																																																																																																																																																																																																																		
609 brake function	<input type="checkbox"/>	<input type="checkbox"/>	<input type="checkbox"/>	<input type="checkbox"/>	<input type="checkbox"/>																																																																																																																																																																																																																																																		
610 speed	<input type="checkbox"/>	<input type="checkbox"/>	<input type="checkbox"/>	<input type="checkbox"/>	<input type="checkbox"/>																																																																																																																																																																																																																																																		
611 pressure setting	<input type="checkbox"/>	<input type="checkbox"/>	<input type="checkbox"/>	<input type="checkbox"/>	<input type="checkbox"/>																																																																																																																																																																																																																																																		
612 hydraulic lines	<input type="checkbox"/>	<input type="checkbox"/>	<input type="checkbox"/>	<input type="checkbox"/>	<input type="checkbox"/>																																																																																																																																																																																																																																																		
<b>700 slewing head with slewing column</b>																																																																																																																																																																																																																																																							
701 slewing head	<input type="checkbox"/>	<input type="checkbox"/>	<input type="checkbox"/>	<input type="checkbox"/>	<input type="checkbox"/>																																																																																																																																																																																																																																																		
702 slewing column bearing	<input type="checkbox"/>	<input type="checkbox"/>	<input type="checkbox"/>	<input type="checkbox"/>	<input type="checkbox"/>																																																																																																																																																																																																																																																		
703 slewing drive (tooth backlash)	<input type="checkbox"/>	<input type="checkbox"/>	<input type="checkbox"/>	<input type="checkbox"/>	<input type="checkbox"/>																																																																																																																																																																																																																																																		
704 speed	<input type="checkbox"/>	<input type="checkbox"/>	<input type="checkbox"/>	<input type="checkbox"/>	<input type="checkbox"/>																																																																																																																																																																																																																																																		
705 pressure settings	<input type="checkbox"/>	<input type="checkbox"/>	<input type="checkbox"/>	<input type="checkbox"/>	<input type="checkbox"/>																																																																																																																																																																																																																																																		
706 hydraulic lines	<input type="checkbox"/>	<input type="checkbox"/>	<input type="checkbox"/>	<input type="checkbox"/>	<input type="checkbox"/>																																																																																																																																																																																																																																																		
707 swivel cylinder	<input type="checkbox"/>	<input type="checkbox"/>	<input type="checkbox"/>	<input type="checkbox"/>	<input type="checkbox"/>																																																																																																																																																																																																																																																		
Notes:																																																																																																																																																																																																																																																							

# Inspection report for concrete booms

Inspection report Nr:	Boom type:	Machine-Nr:
-----------------------	------------	-------------

- Error code:**
- |                  |                     |                   |                          |
|------------------|---------------------|-------------------|--------------------------|
| 00 no objections | 08 corrosion        | 16 porous         | 24 deformation           |
| 01 cracks        | 09 lacquer failures | 17 burned through | 25 bear movement         |
| 02 broken        | 10 fraying          | 18 not fixed      | 26 lubrication           |
| 03 leaky         | 11 scratched        | 19 clomp          | 27 readability           |
| 04 no function   | 12 bendet           | 20 sawing         | 28 missing components    |
| 05 low lifetime  | 13 noises           | 21 contaminated   | 29 hydraulical           |
| 06 worn out      | 14 vibration        | 22 bad contact    | 30 electrical            |
| 07 dirt          | 15 miscellaneous    | 23 temperature    | 31 reinspection required |

<table style="width: 100%; border: none;"> <tr><td>800 boom</td><td><input type="checkbox"/></td><td><input type="checkbox"/></td><td><input type="checkbox"/></td><td><input type="checkbox"/></td><td><input type="checkbox"/></td></tr> <tr><td>801 „Arm 1“</td><td><input type="checkbox"/></td><td><input type="checkbox"/></td><td><input type="checkbox"/></td><td><input type="checkbox"/></td><td><input type="checkbox"/></td></tr> <tr><td>802 bracket conveying line</td><td><input type="checkbox"/></td><td><input type="checkbox"/></td><td><input type="checkbox"/></td><td><input type="checkbox"/></td><td><input type="checkbox"/></td></tr> <tr><td>803 Drop hook</td><td><input type="checkbox"/></td><td><input type="checkbox"/></td><td><input type="checkbox"/></td><td><input type="checkbox"/></td><td><input type="checkbox"/></td></tr> <tr><td>804 „Arm 2“</td><td><input type="checkbox"/></td><td><input type="checkbox"/></td><td><input type="checkbox"/></td><td><input type="checkbox"/></td><td><input type="checkbox"/></td></tr> <tr><td>805 bracket conveying line</td><td><input type="checkbox"/></td><td><input type="checkbox"/></td><td><input type="checkbox"/></td><td><input type="checkbox"/></td><td><input type="checkbox"/></td></tr> <tr><td>806 Drop hook</td><td><input type="checkbox"/></td><td><input type="checkbox"/></td><td><input type="checkbox"/></td><td><input type="checkbox"/></td><td><input type="checkbox"/></td></tr> <tr><td>807 „Arm 3“</td><td><input type="checkbox"/></td><td><input type="checkbox"/></td><td><input type="checkbox"/></td><td><input type="checkbox"/></td><td><input type="checkbox"/></td></tr> <tr><td>808 bracket conveying line</td><td><input type="checkbox"/></td><td><input type="checkbox"/></td><td><input type="checkbox"/></td><td><input type="checkbox"/></td><td><input type="checkbox"/></td></tr> <tr><td>809 guidance and interlock of the arm</td><td><input type="checkbox"/></td><td><input type="checkbox"/></td><td><input type="checkbox"/></td><td><input type="checkbox"/></td><td><input type="checkbox"/></td></tr> <tr><td>810 „Arm 4“</td><td><input type="checkbox"/></td><td><input type="checkbox"/></td><td><input type="checkbox"/></td><td><input type="checkbox"/></td><td><input type="checkbox"/></td></tr> <tr><td>811 bracket conveying line</td><td><input type="checkbox"/></td><td><input type="checkbox"/></td><td><input type="checkbox"/></td><td><input type="checkbox"/></td><td><input type="checkbox"/></td></tr> <tr><td>812 guidance and interlock of the arm</td><td><input type="checkbox"/></td><td><input type="checkbox"/></td><td><input type="checkbox"/></td><td><input type="checkbox"/></td><td><input type="checkbox"/></td></tr> <tr><td>813 „Arm 5“</td><td><input type="checkbox"/></td><td><input type="checkbox"/></td><td><input type="checkbox"/></td><td><input type="checkbox"/></td><td><input type="checkbox"/></td></tr> <tr><td>814 bracket conveying line</td><td><input type="checkbox"/></td><td><input type="checkbox"/></td><td><input type="checkbox"/></td><td><input type="checkbox"/></td><td><input type="checkbox"/></td></tr> <tr><td>815 guidance and interlock of the arm</td><td><input type="checkbox"/></td><td><input type="checkbox"/></td><td><input type="checkbox"/></td><td><input type="checkbox"/></td><td><input type="checkbox"/></td></tr> <tr><td>900 joint „A“</td><td><input type="checkbox"/></td><td><input type="checkbox"/></td><td><input type="checkbox"/></td><td><input type="checkbox"/></td><td><input type="checkbox"/></td></tr> <tr><td>901 boom</td><td><input type="checkbox"/></td><td><input type="checkbox"/></td><td><input type="checkbox"/></td><td><input type="checkbox"/></td><td><input type="checkbox"/></td></tr> <tr><td>902 link lever</td><td><input type="checkbox"/></td><td><input type="checkbox"/></td><td><input type="checkbox"/></td><td><input type="checkbox"/></td><td><input type="checkbox"/></td></tr> <tr><td>903 forcing rod</td><td><input type="checkbox"/></td><td><input type="checkbox"/></td><td><input type="checkbox"/></td><td><input type="checkbox"/></td><td><input type="checkbox"/></td></tr> <tr><td>904 pin</td><td><input type="checkbox"/></td><td><input type="checkbox"/></td><td><input type="checkbox"/></td><td><input type="checkbox"/></td><td><input type="checkbox"/></td></tr> <tr><td>905 cylinder</td><td><input type="checkbox"/></td><td><input type="checkbox"/></td><td><input type="checkbox"/></td><td><input type="checkbox"/></td><td><input type="checkbox"/></td></tr> </table>	800 boom	<input type="checkbox"/>	<input type="checkbox"/>	<input type="checkbox"/>	<input type="checkbox"/>	<input type="checkbox"/>	801 „Arm 1“	<input type="checkbox"/>	<input type="checkbox"/>	<input type="checkbox"/>	<input type="checkbox"/>	<input type="checkbox"/>	802 bracket conveying line	<input type="checkbox"/>	<input type="checkbox"/>	<input type="checkbox"/>	<input type="checkbox"/>	<input type="checkbox"/>	803 Drop hook	<input type="checkbox"/>	<input type="checkbox"/>	<input type="checkbox"/>	<input type="checkbox"/>	<input type="checkbox"/>	804 „Arm 2“	<input type="checkbox"/>	<input type="checkbox"/>	<input type="checkbox"/>	<input type="checkbox"/>	<input type="checkbox"/>	805 bracket conveying line	<input type="checkbox"/>	<input type="checkbox"/>	<input type="checkbox"/>	<input type="checkbox"/>	<input type="checkbox"/>	806 Drop hook	<input type="checkbox"/>	<input type="checkbox"/>	<input type="checkbox"/>	<input type="checkbox"/>	<input type="checkbox"/>	807 „Arm 3“	<input type="checkbox"/>	<input type="checkbox"/>	<input type="checkbox"/>	<input type="checkbox"/>	<input type="checkbox"/>	808 bracket conveying line	<input type="checkbox"/>	<input type="checkbox"/>	<input type="checkbox"/>	<input type="checkbox"/>	<input type="checkbox"/>	809 guidance and interlock of the arm	<input type="checkbox"/>	<input type="checkbox"/>	<input type="checkbox"/>	<input type="checkbox"/>	<input type="checkbox"/>	810 „Arm 4“	<input type="checkbox"/>	<input type="checkbox"/>	<input type="checkbox"/>	<input type="checkbox"/>	<input type="checkbox"/>	811 bracket conveying line	<input type="checkbox"/>	<input type="checkbox"/>	<input type="checkbox"/>	<input type="checkbox"/>	<input type="checkbox"/>	812 guidance and interlock of the arm	<input type="checkbox"/>	<input type="checkbox"/>	<input type="checkbox"/>	<input type="checkbox"/>	<input type="checkbox"/>	813 „Arm 5“	<input type="checkbox"/>	<input type="checkbox"/>	<input type="checkbox"/>	<input type="checkbox"/>	<input type="checkbox"/>	814 bracket conveying line	<input type="checkbox"/>	<input type="checkbox"/>	<input type="checkbox"/>	<input type="checkbox"/>	<input type="checkbox"/>	815 guidance and interlock of the arm	<input type="checkbox"/>	<input type="checkbox"/>	<input type="checkbox"/>	<input type="checkbox"/>	<input type="checkbox"/>	900 joint „A“	<input type="checkbox"/>	<input type="checkbox"/>	<input type="checkbox"/>	<input type="checkbox"/>	<input type="checkbox"/>	901 boom	<input type="checkbox"/>	<input type="checkbox"/>	<input type="checkbox"/>	<input type="checkbox"/>	<input type="checkbox"/>	902 link lever	<input type="checkbox"/>	<input type="checkbox"/>	<input type="checkbox"/>	<input type="checkbox"/>	<input type="checkbox"/>	903 forcing rod	<input type="checkbox"/>	<input type="checkbox"/>	<input type="checkbox"/>	<input type="checkbox"/>	<input type="checkbox"/>	904 pin	<input type="checkbox"/>	<input type="checkbox"/>	<input type="checkbox"/>	<input type="checkbox"/>	<input type="checkbox"/>	905 cylinder	<input type="checkbox"/>	<input type="checkbox"/>	<input type="checkbox"/>	<input type="checkbox"/>	<input type="checkbox"/>	<table style="width: 100%; border: none;"> <tr><td>906 boom speed</td><td><input type="checkbox"/></td><td><input type="checkbox"/></td><td><input type="checkbox"/></td><td><input type="checkbox"/></td><td><input type="checkbox"/></td></tr> <tr><td>907 pressure settings</td><td><input type="checkbox"/></td><td><input type="checkbox"/></td><td><input type="checkbox"/></td><td><input type="checkbox"/></td><td><input type="checkbox"/></td></tr> <tr><td>908 hydraulic lines</td><td><input type="checkbox"/></td><td><input type="checkbox"/></td><td><input type="checkbox"/></td><td><input type="checkbox"/></td><td><input type="checkbox"/></td></tr> <tr><td>909 load holding valve (piston side)</td><td><input type="checkbox"/></td><td><input type="checkbox"/></td><td><input type="checkbox"/></td><td><input type="checkbox"/></td><td><input type="checkbox"/></td></tr> <tr><td>910 load holding valve (rod side)</td><td><input type="checkbox"/></td><td><input type="checkbox"/></td><td><input type="checkbox"/></td><td><input type="checkbox"/></td><td><input type="checkbox"/></td></tr> <tr><td>1000 joint „B“</td><td></td><td></td><td></td><td></td><td></td></tr> <tr><td>1001 boom</td><td><input type="checkbox"/></td><td><input type="checkbox"/></td><td><input type="checkbox"/></td><td><input type="checkbox"/></td><td><input type="checkbox"/></td></tr> <tr><td>1002 link lever</td><td><input type="checkbox"/></td><td><input type="checkbox"/></td><td><input type="checkbox"/></td><td><input type="checkbox"/></td><td><input type="checkbox"/></td></tr> <tr><td>1003 forcing rod</td><td><input type="checkbox"/></td><td><input type="checkbox"/></td><td><input type="checkbox"/></td><td><input type="checkbox"/></td><td><input type="checkbox"/></td></tr> <tr><td>1004 pin</td><td><input type="checkbox"/></td><td><input type="checkbox"/></td><td><input type="checkbox"/></td><td><input type="checkbox"/></td><td><input type="checkbox"/></td></tr> <tr><td>1005 cylinder</td><td><input type="checkbox"/></td><td><input type="checkbox"/></td><td><input type="checkbox"/></td><td><input type="checkbox"/></td><td><input type="checkbox"/></td></tr> <tr><td>1006 boom speed</td><td><input type="checkbox"/></td><td><input type="checkbox"/></td><td><input type="checkbox"/></td><td><input type="checkbox"/></td><td><input type="checkbox"/></td></tr> <tr><td>1007 pressure settings</td><td><input type="checkbox"/></td><td><input type="checkbox"/></td><td><input type="checkbox"/></td><td><input type="checkbox"/></td><td><input type="checkbox"/></td></tr> <tr><td>1008 hydraulic lines</td><td><input type="checkbox"/></td><td><input type="checkbox"/></td><td><input type="checkbox"/></td><td><input type="checkbox"/></td><td><input type="checkbox"/></td></tr> <tr><td>1009 load holding valve (piston side)</td><td><input type="checkbox"/></td><td><input type="checkbox"/></td><td><input type="checkbox"/></td><td><input type="checkbox"/></td><td><input type="checkbox"/></td></tr> <tr><td>1010 load holding valve (rod side)</td><td><input type="checkbox"/></td><td><input type="checkbox"/></td><td><input type="checkbox"/></td><td><input type="checkbox"/></td><td><input type="checkbox"/></td></tr> </table> <p>Notes:</p> <hr/> <hr/> <hr/> <hr/>	906 boom speed	<input type="checkbox"/>	<input type="checkbox"/>	<input type="checkbox"/>	<input type="checkbox"/>	<input type="checkbox"/>	907 pressure settings	<input type="checkbox"/>	<input type="checkbox"/>	<input type="checkbox"/>	<input type="checkbox"/>	<input type="checkbox"/>	908 hydraulic lines	<input type="checkbox"/>	<input type="checkbox"/>	<input type="checkbox"/>	<input type="checkbox"/>	<input type="checkbox"/>	909 load holding valve (piston side)	<input type="checkbox"/>	<input type="checkbox"/>	<input type="checkbox"/>	<input type="checkbox"/>	<input type="checkbox"/>	910 load holding valve (rod side)	<input type="checkbox"/>	<input type="checkbox"/>	<input type="checkbox"/>	<input type="checkbox"/>	<input type="checkbox"/>	1000 joint „B“						1001 boom	<input type="checkbox"/>	<input type="checkbox"/>	<input type="checkbox"/>	<input type="checkbox"/>	<input type="checkbox"/>	1002 link lever	<input type="checkbox"/>	<input type="checkbox"/>	<input type="checkbox"/>	<input type="checkbox"/>	<input type="checkbox"/>	1003 forcing rod	<input type="checkbox"/>	<input type="checkbox"/>	<input type="checkbox"/>	<input type="checkbox"/>	<input type="checkbox"/>	1004 pin	<input type="checkbox"/>	<input type="checkbox"/>	<input type="checkbox"/>	<input type="checkbox"/>	<input type="checkbox"/>	1005 cylinder	<input type="checkbox"/>	<input type="checkbox"/>	<input type="checkbox"/>	<input type="checkbox"/>	<input type="checkbox"/>	1006 boom speed	<input type="checkbox"/>	<input type="checkbox"/>	<input type="checkbox"/>	<input type="checkbox"/>	<input type="checkbox"/>	1007 pressure settings	<input type="checkbox"/>	<input type="checkbox"/>	<input type="checkbox"/>	<input type="checkbox"/>	<input type="checkbox"/>	1008 hydraulic lines	<input type="checkbox"/>	<input type="checkbox"/>	<input type="checkbox"/>	<input type="checkbox"/>	<input type="checkbox"/>	1009 load holding valve (piston side)	<input type="checkbox"/>	<input type="checkbox"/>	<input type="checkbox"/>	<input type="checkbox"/>	<input type="checkbox"/>	1010 load holding valve (rod side)	<input type="checkbox"/>	<input type="checkbox"/>	<input type="checkbox"/>	<input type="checkbox"/>	<input type="checkbox"/>
800 boom	<input type="checkbox"/>	<input type="checkbox"/>	<input type="checkbox"/>	<input type="checkbox"/>	<input type="checkbox"/>																																																																																																																																																																																																																																
801 „Arm 1“	<input type="checkbox"/>	<input type="checkbox"/>	<input type="checkbox"/>	<input type="checkbox"/>	<input type="checkbox"/>																																																																																																																																																																																																																																
802 bracket conveying line	<input type="checkbox"/>	<input type="checkbox"/>	<input type="checkbox"/>	<input type="checkbox"/>	<input type="checkbox"/>																																																																																																																																																																																																																																
803 Drop hook	<input type="checkbox"/>	<input type="checkbox"/>	<input type="checkbox"/>	<input type="checkbox"/>	<input type="checkbox"/>																																																																																																																																																																																																																																
804 „Arm 2“	<input type="checkbox"/>	<input type="checkbox"/>	<input type="checkbox"/>	<input type="checkbox"/>	<input type="checkbox"/>																																																																																																																																																																																																																																
805 bracket conveying line	<input type="checkbox"/>	<input type="checkbox"/>	<input type="checkbox"/>	<input type="checkbox"/>	<input type="checkbox"/>																																																																																																																																																																																																																																
806 Drop hook	<input type="checkbox"/>	<input type="checkbox"/>	<input type="checkbox"/>	<input type="checkbox"/>	<input type="checkbox"/>																																																																																																																																																																																																																																
807 „Arm 3“	<input type="checkbox"/>	<input type="checkbox"/>	<input type="checkbox"/>	<input type="checkbox"/>	<input type="checkbox"/>																																																																																																																																																																																																																																
808 bracket conveying line	<input type="checkbox"/>	<input type="checkbox"/>	<input type="checkbox"/>	<input type="checkbox"/>	<input type="checkbox"/>																																																																																																																																																																																																																																
809 guidance and interlock of the arm	<input type="checkbox"/>	<input type="checkbox"/>	<input type="checkbox"/>	<input type="checkbox"/>	<input type="checkbox"/>																																																																																																																																																																																																																																
810 „Arm 4“	<input type="checkbox"/>	<input type="checkbox"/>	<input type="checkbox"/>	<input type="checkbox"/>	<input type="checkbox"/>																																																																																																																																																																																																																																
811 bracket conveying line	<input type="checkbox"/>	<input type="checkbox"/>	<input type="checkbox"/>	<input type="checkbox"/>	<input type="checkbox"/>																																																																																																																																																																																																																																
812 guidance and interlock of the arm	<input type="checkbox"/>	<input type="checkbox"/>	<input type="checkbox"/>	<input type="checkbox"/>	<input type="checkbox"/>																																																																																																																																																																																																																																
813 „Arm 5“	<input type="checkbox"/>	<input type="checkbox"/>	<input type="checkbox"/>	<input type="checkbox"/>	<input type="checkbox"/>																																																																																																																																																																																																																																
814 bracket conveying line	<input type="checkbox"/>	<input type="checkbox"/>	<input type="checkbox"/>	<input type="checkbox"/>	<input type="checkbox"/>																																																																																																																																																																																																																																
815 guidance and interlock of the arm	<input type="checkbox"/>	<input type="checkbox"/>	<input type="checkbox"/>	<input type="checkbox"/>	<input type="checkbox"/>																																																																																																																																																																																																																																
900 joint „A“	<input type="checkbox"/>	<input type="checkbox"/>	<input type="checkbox"/>	<input type="checkbox"/>	<input type="checkbox"/>																																																																																																																																																																																																																																
901 boom	<input type="checkbox"/>	<input type="checkbox"/>	<input type="checkbox"/>	<input type="checkbox"/>	<input type="checkbox"/>																																																																																																																																																																																																																																
902 link lever	<input type="checkbox"/>	<input type="checkbox"/>	<input type="checkbox"/>	<input type="checkbox"/>	<input type="checkbox"/>																																																																																																																																																																																																																																
903 forcing rod	<input type="checkbox"/>	<input type="checkbox"/>	<input type="checkbox"/>	<input type="checkbox"/>	<input type="checkbox"/>																																																																																																																																																																																																																																
904 pin	<input type="checkbox"/>	<input type="checkbox"/>	<input type="checkbox"/>	<input type="checkbox"/>	<input type="checkbox"/>																																																																																																																																																																																																																																
905 cylinder	<input type="checkbox"/>	<input type="checkbox"/>	<input type="checkbox"/>	<input type="checkbox"/>	<input type="checkbox"/>																																																																																																																																																																																																																																
906 boom speed	<input type="checkbox"/>	<input type="checkbox"/>	<input type="checkbox"/>	<input type="checkbox"/>	<input type="checkbox"/>																																																																																																																																																																																																																																
907 pressure settings	<input type="checkbox"/>	<input type="checkbox"/>	<input type="checkbox"/>	<input type="checkbox"/>	<input type="checkbox"/>																																																																																																																																																																																																																																
908 hydraulic lines	<input type="checkbox"/>	<input type="checkbox"/>	<input type="checkbox"/>	<input type="checkbox"/>	<input type="checkbox"/>																																																																																																																																																																																																																																
909 load holding valve (piston side)	<input type="checkbox"/>	<input type="checkbox"/>	<input type="checkbox"/>	<input type="checkbox"/>	<input type="checkbox"/>																																																																																																																																																																																																																																
910 load holding valve (rod side)	<input type="checkbox"/>	<input type="checkbox"/>	<input type="checkbox"/>	<input type="checkbox"/>	<input type="checkbox"/>																																																																																																																																																																																																																																
1000 joint „B“																																																																																																																																																																																																																																					
1001 boom	<input type="checkbox"/>	<input type="checkbox"/>	<input type="checkbox"/>	<input type="checkbox"/>	<input type="checkbox"/>																																																																																																																																																																																																																																
1002 link lever	<input type="checkbox"/>	<input type="checkbox"/>	<input type="checkbox"/>	<input type="checkbox"/>	<input type="checkbox"/>																																																																																																																																																																																																																																
1003 forcing rod	<input type="checkbox"/>	<input type="checkbox"/>	<input type="checkbox"/>	<input type="checkbox"/>	<input type="checkbox"/>																																																																																																																																																																																																																																
1004 pin	<input type="checkbox"/>	<input type="checkbox"/>	<input type="checkbox"/>	<input type="checkbox"/>	<input type="checkbox"/>																																																																																																																																																																																																																																
1005 cylinder	<input type="checkbox"/>	<input type="checkbox"/>	<input type="checkbox"/>	<input type="checkbox"/>	<input type="checkbox"/>																																																																																																																																																																																																																																
1006 boom speed	<input type="checkbox"/>	<input type="checkbox"/>	<input type="checkbox"/>	<input type="checkbox"/>	<input type="checkbox"/>																																																																																																																																																																																																																																
1007 pressure settings	<input type="checkbox"/>	<input type="checkbox"/>	<input type="checkbox"/>	<input type="checkbox"/>	<input type="checkbox"/>																																																																																																																																																																																																																																
1008 hydraulic lines	<input type="checkbox"/>	<input type="checkbox"/>	<input type="checkbox"/>	<input type="checkbox"/>	<input type="checkbox"/>																																																																																																																																																																																																																																
1009 load holding valve (piston side)	<input type="checkbox"/>	<input type="checkbox"/>	<input type="checkbox"/>	<input type="checkbox"/>	<input type="checkbox"/>																																																																																																																																																																																																																																
1010 load holding valve (rod side)	<input type="checkbox"/>	<input type="checkbox"/>	<input type="checkbox"/>	<input type="checkbox"/>	<input type="checkbox"/>																																																																																																																																																																																																																																

# Inspection report for concrete booms

Inspection report Nr: \_\_\_\_\_ Boom type: \_\_\_\_\_ Machine-Nr: \_\_\_\_\_

**Error code:**

- |                  |                     |                   |                          |
|------------------|---------------------|-------------------|--------------------------|
| 00 no objections | 08 corrosion        | 16 porous         | 24 deformation           |
| 01 cracks        | 09 lacquer failures | 17 burned through | 25 bear movement         |
| 02 broken        | 10 fraying          | 18 not fixed      | 26 lubrication           |
| 03 leaky         | 11 scratched        | 19 clomp          | 27 readability           |
| 04 no function   | 12 bendet           | 20 sawing         | 28 missing components    |
| 05 low lifetime  | 13 noises           | 21 contaminated   | 29 hydraulical           |
| 06 worn out      | 14 vibration        | 22 bad contact    | 30 electrical            |
| 07 dirt          | 15 miscellaneous    | 23 temperature    | 31 reinspection required |

**1100 joint "C"**

1101 boom	<input type="checkbox"/>	<input type="checkbox"/>	<input type="checkbox"/>	<input type="checkbox"/>	<input type="checkbox"/>
1102 link lever	<input type="checkbox"/>	<input type="checkbox"/>	<input type="checkbox"/>	<input type="checkbox"/>	<input type="checkbox"/>
1103 forcing rod	<input type="checkbox"/>	<input type="checkbox"/>	<input type="checkbox"/>	<input type="checkbox"/>	<input type="checkbox"/>
1104 pin	<input type="checkbox"/>	<input type="checkbox"/>	<input type="checkbox"/>	<input type="checkbox"/>	<input type="checkbox"/>
1105 cylinder	<input type="checkbox"/>	<input type="checkbox"/>	<input type="checkbox"/>	<input type="checkbox"/>	<input type="checkbox"/>
1106 boom speed	<input type="checkbox"/>	<input type="checkbox"/>	<input type="checkbox"/>	<input type="checkbox"/>	<input type="checkbox"/>
1107 pressure settings	<input type="checkbox"/>	<input type="checkbox"/>	<input type="checkbox"/>	<input type="checkbox"/>	<input type="checkbox"/>
1108 hydraulic lines	<input type="checkbox"/>	<input type="checkbox"/>	<input type="checkbox"/>	<input type="checkbox"/>	<input type="checkbox"/>
1109 load holding valve (piston side)	<input type="checkbox"/>	<input type="checkbox"/>	<input type="checkbox"/>	<input type="checkbox"/>	<input type="checkbox"/>
1110 load holding valve (rod side)	<input type="checkbox"/>	<input type="checkbox"/>	<input type="checkbox"/>	<input type="checkbox"/>	<input type="checkbox"/>

**1200 joint "D"**

1201 boom	<input type="checkbox"/>	<input type="checkbox"/>	<input type="checkbox"/>	<input type="checkbox"/>	<input type="checkbox"/>
1202 link lever	<input type="checkbox"/>	<input type="checkbox"/>	<input type="checkbox"/>	<input type="checkbox"/>	<input type="checkbox"/>
1203 forcing rod	<input type="checkbox"/>	<input type="checkbox"/>	<input type="checkbox"/>	<input type="checkbox"/>	<input type="checkbox"/>
1204 pin	<input type="checkbox"/>	<input type="checkbox"/>	<input type="checkbox"/>	<input type="checkbox"/>	<input type="checkbox"/>
1205 cylinder	<input type="checkbox"/>	<input type="checkbox"/>	<input type="checkbox"/>	<input type="checkbox"/>	<input type="checkbox"/>
1206 boom speed	<input type="checkbox"/>	<input type="checkbox"/>	<input type="checkbox"/>	<input type="checkbox"/>	<input type="checkbox"/>
1207 pressure settings	<input type="checkbox"/>	<input type="checkbox"/>	<input type="checkbox"/>	<input type="checkbox"/>	<input type="checkbox"/>
1208 hydraulic lines	<input type="checkbox"/>	<input type="checkbox"/>	<input type="checkbox"/>	<input type="checkbox"/>	<input type="checkbox"/>
1209 load holding valve (piston side)	<input type="checkbox"/>	<input type="checkbox"/>	<input type="checkbox"/>	<input type="checkbox"/>	<input type="checkbox"/>
1210 load holding valve (rod side)	<input type="checkbox"/>	<input type="checkbox"/>	<input type="checkbox"/>	<input type="checkbox"/>	<input type="checkbox"/>

**1300 joint „E“**

1301 boom	<input type="checkbox"/>	<input type="checkbox"/>	<input type="checkbox"/>	<input type="checkbox"/>	<input type="checkbox"/>
1302 link lever	<input type="checkbox"/>	<input type="checkbox"/>	<input type="checkbox"/>	<input type="checkbox"/>	<input type="checkbox"/>
1303 forcing rod	<input type="checkbox"/>	<input type="checkbox"/>	<input type="checkbox"/>	<input type="checkbox"/>	<input type="checkbox"/>
1304 pin	<input type="checkbox"/>	<input type="checkbox"/>	<input type="checkbox"/>	<input type="checkbox"/>	<input type="checkbox"/>
1305 cylinder	<input type="checkbox"/>	<input type="checkbox"/>	<input type="checkbox"/>	<input type="checkbox"/>	<input type="checkbox"/>
1306 boom speed	<input type="checkbox"/>	<input type="checkbox"/>	<input type="checkbox"/>	<input type="checkbox"/>	<input type="checkbox"/>
1307 pressure settings	<input type="checkbox"/>	<input type="checkbox"/>	<input type="checkbox"/>	<input type="checkbox"/>	<input type="checkbox"/>
1308 hydraulic lines	<input type="checkbox"/>	<input type="checkbox"/>	<input type="checkbox"/>	<input type="checkbox"/>	<input type="checkbox"/>
1309 load holding valve (piston side)	<input type="checkbox"/>	<input type="checkbox"/>	<input type="checkbox"/>	<input type="checkbox"/>	<input type="checkbox"/>
1310 load holding valve (rod side)	<input type="checkbox"/>	<input type="checkbox"/>	<input type="checkbox"/>	<input type="checkbox"/>	<input type="checkbox"/>

**1400 concrete delivery line**

1401 assembly of delivery line DN	<input type="checkbox"/>	<input type="checkbox"/>	<input type="checkbox"/>	<input type="checkbox"/>	<input type="checkbox"/>
1402 end hose DN+Henght	<input type="checkbox"/>	<input type="checkbox"/>	<input type="checkbox"/>	<input type="checkbox"/>	<input type="checkbox"/>
1403 delivery line DN	<input type="checkbox"/>	<input type="checkbox"/>	<input type="checkbox"/>	<input type="checkbox"/>	<input type="checkbox"/>
1404 rotating joints of - delivery line	<input type="checkbox"/>	<input type="checkbox"/>	<input type="checkbox"/>	<input type="checkbox"/>	<input type="checkbox"/>
1405 locking pin of the coupling	<input type="checkbox"/>	<input type="checkbox"/>	<input type="checkbox"/>	<input type="checkbox"/>	<input type="checkbox"/>

Notes:

## Inspection report for concrete booms

Page 5-5

Inspection report Nr: \_\_\_\_\_ Boom type: \_\_\_\_\_ Machine-Nr: \_\_\_\_\_

**Error code:**

- |                  |                     |                   |                          |
|------------------|---------------------|-------------------|--------------------------|
| 00 no objections | 08 corrosion        | 16 porous         | 24 deformation           |
| 01 cracks        | 09 lacquer failures | 17 burned through | 25 bear movement         |
| 02 broken        | 10 fraying          | 18 not fixed      | 26 lubrication           |
| 03 leaky         | 11 scratched        | 19 clomp          | 27 readability           |
| 04 no function   | 12 bendet           | 20 sawing         | 28 missing components    |
| 05 low lifetime  | 13 noises           | 21 contaminated   | 29 hydraulical           |
| 06 worn out      | 14 vibration        | 22 bad contact    | 30 electrical            |
| 07 dirt          | 15 miscellaneous    | 23 temperature    | 31 reinspection required |

1406 end hose safety device

1407 reducer

1408 gate elbow, elbow 6"

**1500 hydraulic system and hydraulic valves**

1501 Pressure relief valve

1502 pressure settings

1503 hydraulic lines

1504 hand operating-  
(function)

1505 boom control valve

1506 hydraulic pump

**1600 electric equipment**

1601 remote control  
(functions)

1602 emergency stop  
(function)

1603 switch for outrigger  
function

1604 switch for boom  
function

1605 wiring harness

1606 central lubrication

**1700 sticker sets**

1701 safety hints

1702 description

1703 operating

1704 short operating  
instruction

1705 sticker „don't use  
the boom as crane“

1706 sticker „guideline  
operating with boom-  
and concrete pump“

1707 name plate

1708 sticker „danger  
high voltage“

**Competent inspector:**

Date: \_\_\_\_\_

Name: \_\_\_\_\_

Signature: \_\_\_\_\_  
(stamp)

**Customer:**

Signature: \_\_\_\_\_  
(stamp)

# Inspection report for concrete pump

Inspection report Nr:	Machine-Nr:	Hours of operation:
		Concrete output m <sup>3</sup> :
Company:	Post code:	City:

NL	WV
----	----

**Proof – Result of the tests**

without defects	defects	reinspection required	shut down
<input type="checkbox"/>	<input type="checkbox"/>	<input type="checkbox"/>	<input type="checkbox"/>

Reinspection until date: .....

**Error code:**

- |                  |                     |                   |                          |
|------------------|---------------------|-------------------|--------------------------|
| 00 no objections | 08 corrosion        | 16 porous         | 24 deformation           |
| 01 cracks        | 09 lacquer failures | 17 burned through | 25 bear movement         |
| 02 broken        | 10 fraying          | 18 not fixed      | 26 lubrication           |
| 03 leaky         | 11 scratched        | 19 clomp          | 27 readability           |
| 04 no fuction    | 12 bendet           | 20 sawing         | 28 missing components    |
| 05 low livetime  | 13 noises           | 21 contaminated   | 29 hydraulical           |
| 06 worn out      | 14 vibration        | 22 bad contact    | 30 electrical            |
| 07 dirt          | 15 miscellaneous    | 23 temperature    | 31 reinspection required |

**2000 documents**

2001 operating manual	<input type="checkbox"/>	<input type="checkbox"/>	<input type="checkbox"/>	<input type="checkbox"/>	<input type="checkbox"/>
2002 spare parts list	<input type="checkbox"/>	<input type="checkbox"/>	<input type="checkbox"/>	<input type="checkbox"/>	<input type="checkbox"/>
<b>2100 drive assembly</b>					
2101 coupling and flange	<input type="checkbox"/>	<input type="checkbox"/>	<input type="checkbox"/>	<input type="checkbox"/>	<input type="checkbox"/>
2200 gear box	<input type="checkbox"/>	<input type="checkbox"/>	<input type="checkbox"/>	<input type="checkbox"/>	<input type="checkbox"/>
2300 hydraulic pump (main)	<input type="checkbox"/>	<input type="checkbox"/>	<input type="checkbox"/>	<input type="checkbox"/>	<input type="checkbox"/>
2400 oil-tank	<input type="checkbox"/>	<input type="checkbox"/>	<input type="checkbox"/>	<input type="checkbox"/>	<input type="checkbox"/>
2500 drive shaft	<input type="checkbox"/>	<input type="checkbox"/>	<input type="checkbox"/>	<input type="checkbox"/>	<input type="checkbox"/>

**2700 hydraulic control system**

2701 pressure relief valve	<input type="checkbox"/>	<input type="checkbox"/>	<input type="checkbox"/>	<input type="checkbox"/>	<input type="checkbox"/>
2702 pressure setting	<input type="checkbox"/>	<input type="checkbox"/>	<input type="checkbox"/>	<input type="checkbox"/>	<input type="checkbox"/>
2703 hydraulic line	<input type="checkbox"/>	<input type="checkbox"/>	<input type="checkbox"/>	<input type="checkbox"/>	<input type="checkbox"/>
2704 mechanical operation by hand	<input type="checkbox"/>	<input type="checkbox"/>	<input type="checkbox"/>	<input type="checkbox"/>	<input type="checkbox"/>
2800 oil –cooler	<input type="checkbox"/>	<input type="checkbox"/>	<input type="checkbox"/>	<input type="checkbox"/>	<input type="checkbox"/>
2900 accumulator	<input type="checkbox"/>	<input type="checkbox"/>	<input type="checkbox"/>	<input type="checkbox"/>	<input type="checkbox"/>
2901 proofs of the required tests according to accumulator regulation	<input type="checkbox"/>	<input type="checkbox"/>	<input type="checkbox"/>	<input type="checkbox"/>	<input type="checkbox"/>
2902 pressure gauge	<input type="checkbox"/>	<input type="checkbox"/>	<input type="checkbox"/>	<input type="checkbox"/>	<input type="checkbox"/>

Notes:



# Inspection report for concrete pump

Inspection report Nr: \_\_\_\_\_ Machine-Nr: \_\_\_\_\_

**Error code:**

- |                  |                     |                   |                          |
|------------------|---------------------|-------------------|--------------------------|
| 00 no objections | 08 corrosion        | 16 porous         | 24 deformation           |
| 01 cracks        | 09 lacquer failures | 17 burned through | 25 bear movement         |
| 02 broken        | 10 fraying          | 18 not fixed      | 26 lubrication           |
| 03 leaky         | 11 scratched        | 19 clump          | 27 readability           |
| 04 no function   | 12 bendet           | 20 sawing         | 28 missing components    |
| 05 low lifetime  | 13 noises           | 21 contaminated   | 29 hydraulical           |
| 06 worn out      | 14 vibration        | 22 bad contact    | 30 electrical            |
| 07 dirt          | 15 miscellaneous    | 23 temperature    | 31 reinspection required |

<p><b>3000 central lubrication</b>    <input type="checkbox"/> <input type="checkbox"/> <input type="checkbox"/> <input type="checkbox"/> <input type="checkbox"/></p> <p><b>3100 hydraulic motor</b>    <input type="checkbox"/> <input type="checkbox"/> <input type="checkbox"/> <input type="checkbox"/> <input type="checkbox"/></p> <p><b>3200 hydraulic lines</b>    <input type="checkbox"/> <input type="checkbox"/> <input type="checkbox"/> <input type="checkbox"/> <input type="checkbox"/></p> <p><b>3300 air compressor</b>    <input type="checkbox"/> <input type="checkbox"/> <input type="checkbox"/> <input type="checkbox"/> <input type="checkbox"/></p> <p><b>3400 control panel</b>    <input type="checkbox"/> <input type="checkbox"/> <input type="checkbox"/> <input type="checkbox"/> <input type="checkbox"/></p> <p><b>3500 concrete pump</b>    <input type="checkbox"/> <input type="checkbox"/> <input type="checkbox"/> <input type="checkbox"/> <input type="checkbox"/></p> <p><b>3700 S-valve</b>    <input type="checkbox"/> <input type="checkbox"/> <input type="checkbox"/> <input type="checkbox"/> <input type="checkbox"/></p> <p><b>3800 hopper</b>    <input type="checkbox"/> <input type="checkbox"/> <input type="checkbox"/> <input type="checkbox"/> <input type="checkbox"/></p> <p><b>4100 sub frame</b>    <input type="checkbox"/> <input type="checkbox"/> <input type="checkbox"/> <input type="checkbox"/> <input type="checkbox"/></p> <p><b>4200 water tank</b>    <input type="checkbox"/> <input type="checkbox"/> <input type="checkbox"/> <input type="checkbox"/> <input type="checkbox"/></p> <p><b>4300 axle</b>    <input type="checkbox"/> <input type="checkbox"/> <input type="checkbox"/> <input type="checkbox"/> <input type="checkbox"/></p> <p><b>4400 water pump</b>    <input type="checkbox"/> <input type="checkbox"/> <input type="checkbox"/> <input type="checkbox"/> <input type="checkbox"/></p> <p><b>4500 vibrator</b>    <input type="checkbox"/> <input type="checkbox"/> <input type="checkbox"/> <input type="checkbox"/> <input type="checkbox"/></p>	<p><b>4600 safety guards, equipment</b></p> <p><b>4601 stair</b>    <input type="checkbox"/> <input type="checkbox"/> <input type="checkbox"/> <input type="checkbox"/> <input type="checkbox"/></p> <p><b>4602 safety for stair</b>    <input type="checkbox"/> <input type="checkbox"/> <input type="checkbox"/> <input type="checkbox"/> <input type="checkbox"/></p> <p><b>4603 handrail</b>    <input type="checkbox"/> <input type="checkbox"/> <input type="checkbox"/> <input type="checkbox"/> <input type="checkbox"/></p> <p><b>4604 hopper grid (fixing device)</b>    <input type="checkbox"/> <input type="checkbox"/> <input type="checkbox"/> <input type="checkbox"/> <input type="checkbox"/></p> <p><b>4606 distance of grid rods</b>    <input type="checkbox"/> <input type="checkbox"/> <input type="checkbox"/> <input type="checkbox"/> <input type="checkbox"/></p> <p><b>4607 distance from grid to agitator</b>    <input type="checkbox"/> <input type="checkbox"/> <input type="checkbox"/> <input type="checkbox"/> <input type="checkbox"/></p> <p><b>4609 agitator have to stop if grid is open</b>    <input type="checkbox"/> <input type="checkbox"/> <input type="checkbox"/> <input type="checkbox"/> <input type="checkbox"/></p> <p><b>4610 accumulator have to dump if grid is open</b>    <input type="checkbox"/> <input type="checkbox"/> <input type="checkbox"/> <input type="checkbox"/> <input type="checkbox"/></p> <p><b>4612 cleaning flap hopper</b>    <input type="checkbox"/> <input type="checkbox"/> <input type="checkbox"/> <input type="checkbox"/> <input type="checkbox"/></p> <p><b>4613 safety grid into water box</b>    <input type="checkbox"/> <input type="checkbox"/> <input type="checkbox"/> <input type="checkbox"/> <input type="checkbox"/></p>
--	---

**Notes:**

---



---



---



---

# Inspection report for concrete pump

Inspection report Nr: \_\_\_\_\_ Machine-Nr: \_\_\_\_\_

**Error code:**

- |                  |                     |                   |                          |
|------------------|---------------------|-------------------|--------------------------|
| 00 no objections | 08 corrosion        | 16 porous         | 24 deformation           |
| 01 cracks        | 09 lacquer failures | 17 burned through | 25 bear movement         |
| 02 broken        | 10 fraying          | 18 not fixed      | 26 lubrication           |
| 03 leaky         | 11 scratched        | 19 clomp          | 27 readability           |
| 04 no function   | 12 bendet           | 20 sawing         | 28 missing components    |
| 05 low lifetime  | 13 noises           | 21 contamitated   | 29 hydraulical           |
| 06 worn out      | 14 vibration        | 22 bad contact    | 30 electrical            |
| 07 dirt          | 15 miscellaneous    | 23 temperature    | 31 reinspection required |

4614 cover for rotating wave

4616 cover for chains

4617 cover for shift cylinder

4618 cover for moving parts

4619 cover for the exhaust pipe

**4700 electrical system**

4701 function of actuator component

4702 emergency stop function

4703 ground connections

4704 cables and wiring harness

4705 temperature switch

**4800 outrigger - system**

4801 transportation lock

4802 locking device

4803 backing plate

4804 jack cylinder connections

4805 pressure adjustment of jack cylinder

**4900 miscellaneous**

4901 additional assembled part from operator

4902 changes through operator

**Competent inspector:**

Date: .....

Name: .....

Signature: .....  
(stamp)

**Customer:**

Signature: .....  
(stamp)

**This test report is filed into the test book**

# Inspection report for concrete booms

Inspection report -Nr:	Machine-Nr	Hours of operation:
Company:	Post code:	Concrete output m <sup>3</sup> :
Boom Type:	Boom Nr.	NL                      WV

**Proof - Result of the Tests**

without defects	defects	reinspection required	shut down
<input type="checkbox"/>	<input type="checkbox"/>	<input type="checkbox"/>	<input type="checkbox"/>

Reinspection until date:.....

**Error code:**

- |                  |                     |                   |                          |
|------------------|---------------------|-------------------|--------------------------|
| 00 no objections | 08 corrosion        | 16 porous         | 24 deformation           |
| 01 cracks        | 09 lacquer failures | 17 burned through | 25 bear movement         |
| 02 broken        | 10 fraying          | 18 not fixed      | 26 lubrication           |
| 03 leaky         | 11 scratched        | 19 clomp          | 27 readability           |
| 04 no function   | 12 bendet           | 20 sawing         | 28 missing components    |
| 05 low lifetime  | 13 noises           | 21 contaminated   | 29 hydraulical           |
| 06 worn out      | 14 vibration        | 22 bad contact    | 30 electrical            |
| 07 dirt          | 15 miscellaneous    | 23 temperature    | 31 reinspection required |

<p><b>100 documents</b></p> <p>101 instruction manual    <input type="checkbox"/> <input type="checkbox"/> <input type="checkbox"/> <input type="checkbox"/> <input type="checkbox"/></p> <p>102 spare parts list        <input type="checkbox"/> <input type="checkbox"/> <input type="checkbox"/> <input type="checkbox"/> <input type="checkbox"/></p> <p><b>200 sub frame</b></p> <p>201 frame connection cpl.   <input type="checkbox"/> <input type="checkbox"/> <input type="checkbox"/> <input type="checkbox"/> <input type="checkbox"/></p> <p><b>300 outrigger front R+L</b></p> <p>301 transportation safety device   <input type="checkbox"/> <input type="checkbox"/> <input type="checkbox"/> <input type="checkbox"/> <input type="checkbox"/></p> <p>302 outrigger                    <input type="checkbox"/> <input type="checkbox"/> <input type="checkbox"/> <input type="checkbox"/> <input type="checkbox"/></p> <p>303 extension box               <input type="checkbox"/> <input type="checkbox"/> <input type="checkbox"/> <input type="checkbox"/> <input type="checkbox"/></p> <p>304 locking device               <input type="checkbox"/> <input type="checkbox"/> <input type="checkbox"/> <input type="checkbox"/> <input type="checkbox"/></p> <p>305 slewing bearing             <input type="checkbox"/> <input type="checkbox"/> <input type="checkbox"/> <input type="checkbox"/> <input type="checkbox"/></p> <p>306 turn locking device         <input type="checkbox"/> <input type="checkbox"/> <input type="checkbox"/> <input type="checkbox"/> <input type="checkbox"/></p> <p>307 support safeguard         <input type="checkbox"/> <input type="checkbox"/> <input type="checkbox"/> <input type="checkbox"/> <input type="checkbox"/></p> <p>308 support plate                <input type="checkbox"/> <input type="checkbox"/> <input type="checkbox"/> <input type="checkbox"/> <input type="checkbox"/></p> <p>309 fixing of jack cylinder     <input type="checkbox"/> <input type="checkbox"/> <input type="checkbox"/> <input type="checkbox"/> <input type="checkbox"/></p> <p>310 jack cylinder                <input type="checkbox"/> <input type="checkbox"/> <input type="checkbox"/> <input type="checkbox"/> <input type="checkbox"/></p>	<p>311 swing cylinder            <input type="checkbox"/> <input type="checkbox"/> <input type="checkbox"/> <input type="checkbox"/> <input type="checkbox"/></p> <p>312 telescopic-cylinder      <input type="checkbox"/> <input type="checkbox"/> <input type="checkbox"/> <input type="checkbox"/> <input type="checkbox"/></p> <p>313 pressure adjustment     <input type="checkbox"/> <input type="checkbox"/> <input type="checkbox"/> <input type="checkbox"/> <input type="checkbox"/></p> <p><b>400 outrigger rear L+R</b></p> <p>401 transportation safety device   <input type="checkbox"/> <input type="checkbox"/> <input type="checkbox"/> <input type="checkbox"/> <input type="checkbox"/></p> <p>402 outrigger                    <input type="checkbox"/> <input type="checkbox"/> <input type="checkbox"/> <input type="checkbox"/> <input type="checkbox"/></p> <p>403 extension box               <input type="checkbox"/> <input type="checkbox"/> <input type="checkbox"/> <input type="checkbox"/> <input type="checkbox"/></p> <p>405 locking device               <input type="checkbox"/> <input type="checkbox"/> <input type="checkbox"/> <input type="checkbox"/> <input type="checkbox"/></p> <p><b>Notes:</b></p> <hr/> <hr/> <hr/> <hr/> <hr/> <hr/>
--	---

# Inspection report for concrete booms

Inspection report Nr: \_\_\_\_\_ Boom type: \_\_\_\_\_ Machine-Nr: \_\_\_\_\_

<b>Error code:</b>			
00 no objections	08 corrosion	16 porous	24 deformation
01 cracks	09 lacquer failures	17 burned through	25 bear movement
02 broken	10 fraying	18 not fixed	26 lubrication
03 leaky	11 scratched	19 clump	27 readability
04 no function	12 bendet	20 sawing	28 missing components
05 low lifetime	13 noises	21 contaminated	29 hydraulic
06 worn out	14 vibration	22 bad contact	30 electrical
07 dirt	15 miscellaneous	23 temperature	31 reinspection required

<p>406 slewing bearing <input type="checkbox"/> <input type="checkbox"/> <input type="checkbox"/> <input type="checkbox"/> <input type="checkbox"/></p> <p>407 turn locking device <input type="checkbox"/> <input type="checkbox"/> <input type="checkbox"/> <input type="checkbox"/> <input type="checkbox"/></p> <p>408 support safeguard <input type="checkbox"/> <input type="checkbox"/> <input type="checkbox"/> <input type="checkbox"/> <input type="checkbox"/></p> <p>409 support plate <input type="checkbox"/> <input type="checkbox"/> <input type="checkbox"/> <input type="checkbox"/> <input type="checkbox"/></p> <p>410 fixing of jack cylinder <input type="checkbox"/> <input type="checkbox"/> <input type="checkbox"/> <input type="checkbox"/> <input type="checkbox"/></p> <p>411 jack cylinder <input type="checkbox"/> <input type="checkbox"/> <input type="checkbox"/> <input type="checkbox"/> <input type="checkbox"/></p> <p>412 swing cylinder <input type="checkbox"/> <input type="checkbox"/> <input type="checkbox"/> <input type="checkbox"/> <input type="checkbox"/></p> <p>413 telescopic cylinder <input type="checkbox"/> <input type="checkbox"/> <input type="checkbox"/> <input type="checkbox"/> <input type="checkbox"/></p> <p><b>500 pedestal</b></p> <p>501 pedestal mounting <input type="checkbox"/> <input type="checkbox"/> <input type="checkbox"/> <input type="checkbox"/> <input type="checkbox"/></p> <p>502 sub frame <input type="checkbox"/> <input type="checkbox"/> <input type="checkbox"/> <input type="checkbox"/> <input type="checkbox"/></p> <p>503 truck frame <input type="checkbox"/> <input type="checkbox"/> <input type="checkbox"/> <input type="checkbox"/> <input type="checkbox"/></p> <p>504 pedestal (structure) <input type="checkbox"/> <input type="checkbox"/> <input type="checkbox"/> <input type="checkbox"/> <input type="checkbox"/></p> <p>505 boom valve without leaking <input type="checkbox"/> <input type="checkbox"/> <input type="checkbox"/> <input type="checkbox"/> <input type="checkbox"/></p> <p>506 boom rest <input type="checkbox"/> <input type="checkbox"/> <input type="checkbox"/> <input type="checkbox"/> <input type="checkbox"/></p> <p>507 transportation safety device <input type="checkbox"/> <input type="checkbox"/> <input type="checkbox"/> <input type="checkbox"/> <input type="checkbox"/></p> <p>508 hydraulic line <input type="checkbox"/> <input type="checkbox"/> <input type="checkbox"/> <input type="checkbox"/> <input type="checkbox"/></p> <p><b>600 slewing head with ball pivot</b></p> <p>601 slewing head <input type="checkbox"/> <input type="checkbox"/> <input type="checkbox"/> <input type="checkbox"/> <input type="checkbox"/></p> <p>602 ball pivot ring <input type="checkbox"/> <input type="checkbox"/> <input type="checkbox"/> <input type="checkbox"/> <input type="checkbox"/></p> <p>603 mounting ball pivot ring <input type="checkbox"/> <input type="checkbox"/> <input type="checkbox"/> <input type="checkbox"/> <input type="checkbox"/></p> <p>604 drive pinion <input type="checkbox"/> <input type="checkbox"/> <input type="checkbox"/> <input type="checkbox"/> <input type="checkbox"/></p>	<p>605 slewing drive mounting <input type="checkbox"/> <input type="checkbox"/> <input type="checkbox"/> <input type="checkbox"/> <input type="checkbox"/></p> <p>606 slewing stop device <input type="checkbox"/> <input type="checkbox"/> <input type="checkbox"/> <input type="checkbox"/> <input type="checkbox"/></p> <p>607 slewing drive (tooth backlash) <input type="checkbox"/> <input type="checkbox"/> <input type="checkbox"/> <input type="checkbox"/> <input type="checkbox"/></p> <p>608 slewing drive <input type="checkbox"/> <input type="checkbox"/> <input type="checkbox"/> <input type="checkbox"/> <input type="checkbox"/></p> <p>609 brake function <input type="checkbox"/> <input type="checkbox"/> <input type="checkbox"/> <input type="checkbox"/> <input type="checkbox"/></p> <p>610 speed <input type="checkbox"/> <input type="checkbox"/> <input type="checkbox"/> <input type="checkbox"/> <input type="checkbox"/></p> <p>611 pressure setting <input type="checkbox"/> <input type="checkbox"/> <input type="checkbox"/> <input type="checkbox"/> <input type="checkbox"/></p> <p>612 hydraulic lines <input type="checkbox"/> <input type="checkbox"/> <input type="checkbox"/> <input type="checkbox"/> <input type="checkbox"/></p> <p><b>700 slewing head with slewing column</b></p> <p>701 slewing head <input type="checkbox"/> <input type="checkbox"/> <input type="checkbox"/> <input type="checkbox"/> <input type="checkbox"/></p> <p>702 slewing column bearing <input type="checkbox"/> <input type="checkbox"/> <input type="checkbox"/> <input type="checkbox"/> <input type="checkbox"/></p> <p>703 slewing drive (tooth backlash) <input type="checkbox"/> <input type="checkbox"/> <input type="checkbox"/> <input type="checkbox"/> <input type="checkbox"/></p> <p>704 speed <input type="checkbox"/> <input type="checkbox"/> <input type="checkbox"/> <input type="checkbox"/> <input type="checkbox"/></p> <p>705 pressure settings <input type="checkbox"/> <input type="checkbox"/> <input type="checkbox"/> <input type="checkbox"/> <input type="checkbox"/></p> <p>706 hydraulic lines <input type="checkbox"/> <input type="checkbox"/> <input type="checkbox"/> <input type="checkbox"/> <input type="checkbox"/></p> <p>707 swivel cylinder <input type="checkbox"/> <input type="checkbox"/> <input type="checkbox"/> <input type="checkbox"/> <input type="checkbox"/></p> <p>Notes:</p> <hr/> <hr/> <hr/> <hr/>
---	---

# Inspection report for concrete booms

Inspection report Nr: \_\_\_\_\_ Boom type: \_\_\_\_\_ Machine-Nr: \_\_\_\_\_

**Error code:**

- |                  |                     |                   |                          |
|------------------|---------------------|-------------------|--------------------------|
| 00 no objections | 08 corrosion        | 16 porous         | 24 deformation           |
| 01 cracks        | 09 lacquer failures | 17 burned through | 25 bear movement         |
| 02 broken        | 10 fraying          | 18 not fixed      | 26 lubrication           |
| 03 leaky         | 11 scratched        | 19 clomp          | 27 readability           |
| 04 no function   | 12 bendet           | 20 sawing         | 28 missing components    |
| 05 low lifetime  | 13 noises           | 21 contaminated   | 29 hydraulical           |
| 06 worn out      | 14 vibration        | 22 bad contact    | 30 electrical            |
| 07 dirt          | 15 miscellaneous    | 23 temperature    | 31 reinspection required |

<p><b>800 boom</b></p> <p>801 „Arm 1“ <input type="checkbox"/> <input type="checkbox"/> <input type="checkbox"/> <input type="checkbox"/> <input type="checkbox"/></p> <p>802 bracket conveying line <input type="checkbox"/> <input type="checkbox"/> <input type="checkbox"/> <input type="checkbox"/> <input type="checkbox"/></p> <p>803 Drop hook <input type="checkbox"/> <input type="checkbox"/> <input type="checkbox"/> <input type="checkbox"/> <input type="checkbox"/></p> <p>804 „Arm 2“ <input type="checkbox"/> <input type="checkbox"/> <input type="checkbox"/> <input type="checkbox"/> <input type="checkbox"/></p> <p>805 bracket conveying line <input type="checkbox"/> <input type="checkbox"/> <input type="checkbox"/> <input type="checkbox"/> <input type="checkbox"/></p> <p>806 Drop hook <input type="checkbox"/> <input type="checkbox"/> <input type="checkbox"/> <input type="checkbox"/> <input type="checkbox"/></p> <p>807 „Arm 3“ <input type="checkbox"/> <input type="checkbox"/> <input type="checkbox"/> <input type="checkbox"/> <input type="checkbox"/></p> <p>808 bracket conveying line <input type="checkbox"/> <input type="checkbox"/> <input type="checkbox"/> <input type="checkbox"/> <input type="checkbox"/></p> <p>809 guidance and interlock of the arm <input type="checkbox"/> <input type="checkbox"/> <input type="checkbox"/> <input type="checkbox"/> <input type="checkbox"/></p> <p>810 „Arm 4“ <input type="checkbox"/> <input type="checkbox"/> <input type="checkbox"/> <input type="checkbox"/> <input type="checkbox"/></p> <p>811 bracket conveying line <input type="checkbox"/> <input type="checkbox"/> <input type="checkbox"/> <input type="checkbox"/> <input type="checkbox"/></p> <p>812 guidance and interlock of the arm <input type="checkbox"/> <input type="checkbox"/> <input type="checkbox"/> <input type="checkbox"/> <input type="checkbox"/></p> <p>813 „Arm 5“ <input type="checkbox"/> <input type="checkbox"/> <input type="checkbox"/> <input type="checkbox"/> <input type="checkbox"/></p> <p>814 bracket conveying line <input type="checkbox"/> <input type="checkbox"/> <input type="checkbox"/> <input type="checkbox"/> <input type="checkbox"/></p> <p>815 guidance and interlock of the arm <input type="checkbox"/> <input type="checkbox"/> <input type="checkbox"/> <input type="checkbox"/> <input type="checkbox"/></p> <p><b>900 joint „A“</b></p> <p>901 boom <input type="checkbox"/> <input type="checkbox"/> <input type="checkbox"/> <input type="checkbox"/> <input type="checkbox"/></p> <p>902 link lever <input type="checkbox"/> <input type="checkbox"/> <input type="checkbox"/> <input type="checkbox"/> <input type="checkbox"/></p> <p>903 forcing rod <input type="checkbox"/> <input type="checkbox"/> <input type="checkbox"/> <input type="checkbox"/> <input type="checkbox"/></p> <p>904 pin <input type="checkbox"/> <input type="checkbox"/> <input type="checkbox"/> <input type="checkbox"/> <input type="checkbox"/></p> <p>905 cylinder <input type="checkbox"/> <input type="checkbox"/> <input type="checkbox"/> <input type="checkbox"/> <input type="checkbox"/></p>	<p>906 boom speed <input type="checkbox"/> <input type="checkbox"/> <input type="checkbox"/> <input type="checkbox"/> <input type="checkbox"/></p> <p>907 pressure settings <input type="checkbox"/> <input type="checkbox"/> <input type="checkbox"/> <input type="checkbox"/> <input type="checkbox"/></p> <p>908 hydraulic lines <input type="checkbox"/> <input type="checkbox"/> <input type="checkbox"/> <input type="checkbox"/> <input type="checkbox"/></p> <p>909 load holding valve (piston side) <input type="checkbox"/> <input type="checkbox"/> <input type="checkbox"/> <input type="checkbox"/> <input type="checkbox"/></p> <p>910 load holding valve (rod side) <input type="checkbox"/> <input type="checkbox"/> <input type="checkbox"/> <input type="checkbox"/> <input type="checkbox"/></p> <p><b>1000 joint „B“</b></p> <p>1001 boom <input type="checkbox"/> <input type="checkbox"/> <input type="checkbox"/> <input type="checkbox"/> <input type="checkbox"/></p> <p>1002 link lever <input type="checkbox"/> <input type="checkbox"/> <input type="checkbox"/> <input type="checkbox"/> <input type="checkbox"/></p> <p>1003 forcing rod <input type="checkbox"/> <input type="checkbox"/> <input type="checkbox"/> <input type="checkbox"/> <input type="checkbox"/></p> <p>1004 pin <input type="checkbox"/> <input type="checkbox"/> <input type="checkbox"/> <input type="checkbox"/> <input type="checkbox"/></p> <p>1005 cylinder <input type="checkbox"/> <input type="checkbox"/> <input type="checkbox"/> <input type="checkbox"/> <input type="checkbox"/></p> <p>1006 boom speed <input type="checkbox"/> <input type="checkbox"/> <input type="checkbox"/> <input type="checkbox"/> <input type="checkbox"/></p> <p>1007 pressure settings <input type="checkbox"/> <input type="checkbox"/> <input type="checkbox"/> <input type="checkbox"/> <input type="checkbox"/></p> <p>1008 hydraulic lines <input type="checkbox"/> <input type="checkbox"/> <input type="checkbox"/> <input type="checkbox"/> <input type="checkbox"/></p> <p>1009 load holding valve (piston side) <input type="checkbox"/> <input type="checkbox"/> <input type="checkbox"/> <input type="checkbox"/> <input type="checkbox"/></p> <p>1010 load holding valve (rod side) <input type="checkbox"/> <input type="checkbox"/> <input type="checkbox"/> <input type="checkbox"/> <input type="checkbox"/></p> <p>Notes:</p> <hr/> <hr/> <hr/> <hr/>
--	---

# Inspection report for concrete booms

Inspection report Nr: \_\_\_\_\_ Boom type: \_\_\_\_\_ Machine-Nr: \_\_\_\_\_

**Error code:**

- |                  |                     |                   |                          |
|------------------|---------------------|-------------------|--------------------------|
| 00 no objections | 08 corrosion        | 16 porous         | 24 deformation           |
| 01 cracks        | 09 lacquer failures | 17 burned through | 25 bear movement         |
| 02 broken        | 10 fraying          | 18 not fixed      | 26 lubrication           |
| 03 leaky         | 11 scratched        | 19 clomp          | 27 readability           |
| 04 no function   | 12 bendet           | 20 sawing         | 28 missing components    |
| 05 low lifetime  | 13 noises           | 21 contaminated   | 29 hydraulical           |
| 06 worn out      | 14 vibration        | 22 bad contact    | 30 electrical            |
| 07 dirt          | 15 miscellaneous    | 23 temperature    | 31 reinspection required |

**1100 joint "C"**

- |  |                          |                          |                          |                          |                          |
|--|--------------------------|--------------------------|--------------------------|--------------------------|--------------------------|
| 1101 boom                                | <input type="checkbox"/> | <input type="checkbox"/> | <input type="checkbox"/> | <input type="checkbox"/> | <input type="checkbox"/> |
| 1102 link lever                          | <input type="checkbox"/> | <input type="checkbox"/> | <input type="checkbox"/> | <input type="checkbox"/> | <input type="checkbox"/> |
| 1103 forcing rod                         | <input type="checkbox"/> | <input type="checkbox"/> | <input type="checkbox"/> | <input type="checkbox"/> | <input type="checkbox"/> |
| 1104 pin                                 | <input type="checkbox"/> | <input type="checkbox"/> | <input type="checkbox"/> | <input type="checkbox"/> | <input type="checkbox"/> |
| 1105 cylinder                            | <input type="checkbox"/> | <input type="checkbox"/> | <input type="checkbox"/> | <input type="checkbox"/> | <input type="checkbox"/> |
| 1106 boom speed                          | <input type="checkbox"/> | <input type="checkbox"/> | <input type="checkbox"/> | <input type="checkbox"/> | <input type="checkbox"/> |
| 1107 pressure settings                   | <input type="checkbox"/> | <input type="checkbox"/> | <input type="checkbox"/> | <input type="checkbox"/> | <input type="checkbox"/> |
| 1108 hydraulic lines                     | <input type="checkbox"/> | <input type="checkbox"/> | <input type="checkbox"/> | <input type="checkbox"/> | <input type="checkbox"/> |
| 1109 load holding valve<br>(piston side) | <input type="checkbox"/> | <input type="checkbox"/> | <input type="checkbox"/> | <input type="checkbox"/> | <input type="checkbox"/> |
| 1110 load holding valve<br>(rod side)    | <input type="checkbox"/> | <input type="checkbox"/> | <input type="checkbox"/> | <input type="checkbox"/> | <input type="checkbox"/> |

**1200 joint "D"**

- |  |                          |                          |                          |                          |                          |
|--|--------------------------|--------------------------|--------------------------|--------------------------|--------------------------|
| 1201 boom                                | <input type="checkbox"/> | <input type="checkbox"/> | <input type="checkbox"/> | <input type="checkbox"/> | <input type="checkbox"/> |
| 1202 link lever                          | <input type="checkbox"/> | <input type="checkbox"/> | <input type="checkbox"/> | <input type="checkbox"/> | <input type="checkbox"/> |
| 1203 forcing rod                         | <input type="checkbox"/> | <input type="checkbox"/> | <input type="checkbox"/> | <input type="checkbox"/> | <input type="checkbox"/> |
| 1204 pin                                 | <input type="checkbox"/> | <input type="checkbox"/> | <input type="checkbox"/> | <input type="checkbox"/> | <input type="checkbox"/> |
| 1205 cylinder                            | <input type="checkbox"/> | <input type="checkbox"/> | <input type="checkbox"/> | <input type="checkbox"/> | <input type="checkbox"/> |
| 1206 boom speed                          | <input type="checkbox"/> | <input type="checkbox"/> | <input type="checkbox"/> | <input type="checkbox"/> | <input type="checkbox"/> |
| 1207 pressure settings                   | <input type="checkbox"/> | <input type="checkbox"/> | <input type="checkbox"/> | <input type="checkbox"/> | <input type="checkbox"/> |
| 1208 hydraulic lines                     | <input type="checkbox"/> | <input type="checkbox"/> | <input type="checkbox"/> | <input type="checkbox"/> | <input type="checkbox"/> |
| 1209 load holding valve<br>(piston side) | <input type="checkbox"/> | <input type="checkbox"/> | <input type="checkbox"/> | <input type="checkbox"/> | <input type="checkbox"/> |
| 1210 load holding valve<br>(rod side)    | <input type="checkbox"/> | <input type="checkbox"/> | <input type="checkbox"/> | <input type="checkbox"/> | <input type="checkbox"/> |

**1300 joint „E“**

- |  |                          |                          |                          |                          |                          |
|--|--------------------------|--------------------------|--------------------------|--------------------------|--------------------------|
| 1301 boom                                  | <input type="checkbox"/> | <input type="checkbox"/> | <input type="checkbox"/> | <input type="checkbox"/> | <input type="checkbox"/> |
| 1302 link lever                            | <input type="checkbox"/> | <input type="checkbox"/> | <input type="checkbox"/> | <input type="checkbox"/> | <input type="checkbox"/> |
| 1303 forcing rod                           | <input type="checkbox"/> | <input type="checkbox"/> | <input type="checkbox"/> | <input type="checkbox"/> | <input type="checkbox"/> |
| 1304 pin                                   | <input type="checkbox"/> | <input type="checkbox"/> | <input type="checkbox"/> | <input type="checkbox"/> | <input type="checkbox"/> |
| 1305 cylinder                              | <input type="checkbox"/> | <input type="checkbox"/> | <input type="checkbox"/> | <input type="checkbox"/> | <input type="checkbox"/> |
| 1306 boom speed                            | <input type="checkbox"/> | <input type="checkbox"/> | <input type="checkbox"/> | <input type="checkbox"/> | <input type="checkbox"/> |
| 1307 pressure settings                     | <input type="checkbox"/> | <input type="checkbox"/> | <input type="checkbox"/> | <input type="checkbox"/> | <input type="checkbox"/> |
| 1308 hydraulic lines                       | <input type="checkbox"/> | <input type="checkbox"/> | <input type="checkbox"/> | <input type="checkbox"/> | <input type="checkbox"/> |
| 1309 load holding valve<br>(piston side)   | <input type="checkbox"/> | <input type="checkbox"/> | <input type="checkbox"/> | <input type="checkbox"/> | <input type="checkbox"/> |
| 1310 load holding valve<br>(rod side)      | <input type="checkbox"/> | <input type="checkbox"/> | <input type="checkbox"/> | <input type="checkbox"/> | <input type="checkbox"/> |
| <b>1400 concrete delivery line</b>         |                          |                          |                          |                          |                          |
| 1401 assembly of delivery<br>line DN       | <input type="checkbox"/> | <input type="checkbox"/> | <input type="checkbox"/> | <input type="checkbox"/> | <input type="checkbox"/> |
| 1402 end hose<br>DN+height                 | <input type="checkbox"/> | <input type="checkbox"/> | <input type="checkbox"/> | <input type="checkbox"/> | <input type="checkbox"/> |
| 1403 delivery line<br>DN                   | <input type="checkbox"/> | <input type="checkbox"/> | <input type="checkbox"/> | <input type="checkbox"/> | <input type="checkbox"/> |
| 1404 rotating joints of -<br>delivery line | <input type="checkbox"/> | <input type="checkbox"/> | <input type="checkbox"/> | <input type="checkbox"/> | <input type="checkbox"/> |
| 1405 locking pin of the<br>coupling        | <input type="checkbox"/> | <input type="checkbox"/> | <input type="checkbox"/> | <input type="checkbox"/> | <input type="checkbox"/> |

Notes:

## Inspection report for concrete booms

Page 5-5

Inspection report Nr: \_\_\_\_\_ Boom type: \_\_\_\_\_ Machine-Nr: \_\_\_\_\_

**Error code:**

00 no objections	08 corrosion	16 porous	24 deformation
01 cracks	09 lacquer failures	17 burned through	25 bear movement
02 broken	10 fraying	18 not fixed	26 lubrication
03 leaky	11 scratched	19 clomp	27 readability
04 no function	12 bendet	20 sawing	28 missing components
05 low lifetime	13 noises	21 contamitated	29 hydraulical
06 worn out	14 vibration	22 bad contact	30 electrical
07 dirt	15 miscellaneous	23 temperature	31 reinspection required

1406 end hose safety device

1407 reducer

1408 gate elbow, elbow 6"

**1500 hydraulic system and hydraulic valves**

1501 Pressure relief valve

1502 pressure settings

1503 hydraulic lines

1504 hand operating-  
(function)

1505 boom control valve

1506 hydraulic pump

**1600 electric equipment**

1601 remote control  
(functions)

1602 emergency stop  
(function)

1603 switch for outrigger  
function

1604 switch for boom  
function

1605 wiring harness

1606 central lubrication

**1700 sticker sets**

1701 safety hints

1702 description

1703 operating

1704 short operating  
instruction

1705 sticker „don't use  
the boom as crane“

1706 sticker „guideline  
operating with boom-  
and concrete pump“

1707 name plate

1708 sticker „danger  
high voltage“

**Competent inspector:**

Date: \_\_\_\_\_

Name: \_\_\_\_\_

Signature: \_\_\_\_\_  
(stamp)

**Customer:**

Signature: \_\_\_\_\_  
(stamp)

# Inspection report for concrete pump

Inspection report Nr:	Machine-Nr:	Hours of operation:
		Concrete output m³:
Company:	Post code:	City:

NL	WV
----	----

**Proof – Result of the tests**

without defects	defects	reinspection required	shut down
<input type="checkbox"/>	<input type="checkbox"/>	<input type="checkbox"/>	<input type="checkbox"/>

Reinspection until date: .....

**Error code:**

- |                  |                     |                   |                          |
|------------------|---------------------|-------------------|--------------------------|
| 00 no objections | 08 corrosion        | 16 porous         | 24 deformation           |
| 01 cracks        | 09 lacquer failures | 17 burned through | 25 bear movement         |
| 02 broken        | 10 fraying          | 18 not fixed      | 26 lubrication           |
| 03 leaky         | 11 scratched        | 19 clomp          | 27 readability           |
| 04 no fuction    | 12 bendet           | 20 sawing         | 28 missing components    |
| 05 low livetime  | 13 noises           | 21 contaminated   | 29 hydraulical           |
| 06 wom out       | 14 vibration        | 22 bad contact    | 30 electrical            |
| 07 dirt          | 15 miscellaneous    | 23 temperature    | 31 reinspection required |

**2000 documents**

2001 operating manual	<input type="checkbox"/>	<input type="checkbox"/>	<input type="checkbox"/>	<input type="checkbox"/>
2002 spare parts list	<input type="checkbox"/>	<input type="checkbox"/>	<input type="checkbox"/>	<input type="checkbox"/>

**2100 drive assembly**

2101 coupling and flange	<input type="checkbox"/>	<input type="checkbox"/>	<input type="checkbox"/>	<input type="checkbox"/>
--------------------------	--------------------------	--------------------------	--------------------------	--------------------------

**2200 gear box**

2200 gear box	<input type="checkbox"/>	<input type="checkbox"/>	<input type="checkbox"/>	<input type="checkbox"/>
---------------	--------------------------	--------------------------	--------------------------	--------------------------

**2300 hydraulic pump (main)**

2300 hydraulic pump (main)	<input type="checkbox"/>	<input type="checkbox"/>	<input type="checkbox"/>	<input type="checkbox"/>
----------------------------	--------------------------	--------------------------	--------------------------	--------------------------

**2400 oil-tank**

2400 oil-tank	<input type="checkbox"/>	<input type="checkbox"/>	<input type="checkbox"/>	<input type="checkbox"/>
---------------	--------------------------	--------------------------	--------------------------	--------------------------

**2500 drive shaft**

**2700 hydraulic control system**

2701 pressure relief valve	<input type="checkbox"/>	<input type="checkbox"/>	<input type="checkbox"/>	<input type="checkbox"/>
----------------------------	--------------------------	--------------------------	--------------------------	--------------------------

2702 pressure setting	<input type="checkbox"/>	<input type="checkbox"/>	<input type="checkbox"/>	<input type="checkbox"/>
-----------------------	--------------------------	--------------------------	--------------------------	--------------------------

2703 hydraulic line	<input type="checkbox"/>	<input type="checkbox"/>	<input type="checkbox"/>	<input type="checkbox"/>
---------------------	--------------------------	--------------------------	--------------------------	--------------------------

2704 mechanical operation by hand	<input type="checkbox"/>	<input type="checkbox"/>	<input type="checkbox"/>	<input type="checkbox"/>
-----------------------------------	--------------------------	--------------------------	--------------------------	--------------------------

2800 oil-cooler	<input type="checkbox"/>	<input type="checkbox"/>	<input type="checkbox"/>	<input type="checkbox"/>
-----------------	--------------------------	--------------------------	--------------------------	--------------------------

2900 accumulator	<input type="checkbox"/>	<input type="checkbox"/>	<input type="checkbox"/>	<input type="checkbox"/>
------------------	--------------------------	--------------------------	--------------------------	--------------------------

2901 proofs of the required tests according to accumulator regulation	<input type="checkbox"/>	<input type="checkbox"/>	<input type="checkbox"/>	<input type="checkbox"/>
---	--------------------------	--------------------------	--------------------------	--------------------------

2902 pressure gauge	<input type="checkbox"/>	<input type="checkbox"/>	<input type="checkbox"/>	<input type="checkbox"/>
---------------------	--------------------------	--------------------------	--------------------------	--------------------------

Notes:



# Inspection report for concrete pump

Inspection report Nr: \_\_\_\_\_ Machine-Nr: \_\_\_\_\_

**Error code:**

- |                  |                     |                   |                          |
|------------------|---------------------|-------------------|--------------------------|
| 00 no objections | 08 corrosion        | 16 porous         | 24 deformation           |
| 01 cracks        | 09 lacquer failures | 17 burned through | 25 bear movement         |
| 02 broken        | 10 fraying          | 18 not fixed      | 26 lubrication           |
| 03 leaky         | 11 scratched        | 19 clomp          | 27 readability           |
| 04 no function   | 12 bendet           | 20 sawing         | 28 missing components    |
| 05 low lifetime  | 13 noises           | 21 contaminated   | 29 hydraulical           |
| 06 worn out      | 14 vibration        | 22 bad contact    | 30 electrical            |
| 07 dirt          | 15 miscellaneous    | 23 temperature    | 31 reinspection required |

<p><b>3000 central lubrication</b>    <input type="checkbox"/> <input type="checkbox"/> <input type="checkbox"/> <input type="checkbox"/> <input type="checkbox"/></p> <p><b>3100 hydraulic motor</b>    <input type="checkbox"/> <input type="checkbox"/> <input type="checkbox"/> <input type="checkbox"/> <input type="checkbox"/></p> <p><b>3200 hydraulic lines</b>    <input type="checkbox"/> <input type="checkbox"/> <input type="checkbox"/> <input type="checkbox"/> <input type="checkbox"/></p> <p><b>3300 air compressor</b>    <input type="checkbox"/> <input type="checkbox"/> <input type="checkbox"/> <input type="checkbox"/> <input type="checkbox"/></p> <p><b>3400 control panel</b>    <input type="checkbox"/> <input type="checkbox"/> <input type="checkbox"/> <input type="checkbox"/> <input type="checkbox"/></p> <p><b>3500 concrete pump</b>    <input type="checkbox"/> <input type="checkbox"/> <input type="checkbox"/> <input type="checkbox"/> <input type="checkbox"/></p> <p><b>3700 S-valve</b>    <input type="checkbox"/> <input type="checkbox"/> <input type="checkbox"/> <input type="checkbox"/> <input type="checkbox"/></p> <p><b>3800 hopper</b>    <input type="checkbox"/> <input type="checkbox"/> <input type="checkbox"/> <input type="checkbox"/> <input type="checkbox"/></p> <p><b>4100 sub frame</b>    <input type="checkbox"/> <input type="checkbox"/> <input type="checkbox"/> <input type="checkbox"/> <input type="checkbox"/></p> <p><b>4200 water tank</b>    <input type="checkbox"/> <input type="checkbox"/> <input type="checkbox"/> <input type="checkbox"/> <input type="checkbox"/></p> <p><b>4300 axle</b>    <input type="checkbox"/> <input type="checkbox"/> <input type="checkbox"/> <input type="checkbox"/> <input type="checkbox"/></p> <p><b>4400 water pump</b>    <input type="checkbox"/> <input type="checkbox"/> <input type="checkbox"/> <input type="checkbox"/> <input type="checkbox"/></p> <p><b>4500 vibrator</b>    <input type="checkbox"/> <input type="checkbox"/> <input type="checkbox"/> <input type="checkbox"/> <input type="checkbox"/></p>	<p><b>4600 safety guards, equipment</b></p> <p>4601 stair    <input type="checkbox"/> <input type="checkbox"/> <input type="checkbox"/> <input type="checkbox"/> <input type="checkbox"/></p> <p>4602 safety for stair    <input type="checkbox"/> <input type="checkbox"/> <input type="checkbox"/> <input type="checkbox"/> <input type="checkbox"/></p> <p>4603 handrail    <input type="checkbox"/> <input type="checkbox"/> <input type="checkbox"/> <input type="checkbox"/> <input type="checkbox"/></p> <p>4604 hopper grid (fixing device)    <input type="checkbox"/> <input type="checkbox"/> <input type="checkbox"/> <input type="checkbox"/> <input type="checkbox"/></p> <p>4606 distance of grid rods    <input type="checkbox"/> <input type="checkbox"/> <input type="checkbox"/> <input type="checkbox"/> <input type="checkbox"/></p> <p>4607 distance from grid to agitator    <input type="checkbox"/> <input type="checkbox"/> <input type="checkbox"/> <input type="checkbox"/> <input type="checkbox"/></p> <p>4609 agitator have to stop if grid is open    <input type="checkbox"/> <input type="checkbox"/> <input type="checkbox"/> <input type="checkbox"/> <input type="checkbox"/></p> <p>4610 accumulator have to dump if grid is open    <input type="checkbox"/> <input type="checkbox"/> <input type="checkbox"/> <input type="checkbox"/> <input type="checkbox"/></p> <p>4612 cleaning flap hopper    <input type="checkbox"/> <input type="checkbox"/> <input type="checkbox"/> <input type="checkbox"/> <input type="checkbox"/></p> <p>4613 safety grid into water box    <input type="checkbox"/> <input type="checkbox"/> <input type="checkbox"/> <input type="checkbox"/> <input type="checkbox"/></p> <p><b>Notes:</b></p> <hr/> <hr/> <hr/> <hr/>
--	--

# Inspection report for concrete pump

Inspection report Nr: \_\_\_\_\_ Machine-Nr: \_\_\_\_\_

**Error code:**

- |                  |                     |                   |                          |
|------------------|---------------------|-------------------|--------------------------|
| 00 no objections | 08 corrosion        | 16 porous         | 24 deformation           |
| 01 cracks        | 09 lacquer failures | 17 burned through | 25 bear movement         |
| 02 broken        | 10 fraying          | 18 not fixed      | 26 lubrication           |
| 03 leaky         | 11 scratched        | 19 clomp          | 27 readability           |
| 04 no function   | 12 bendet           | 20 sawing         | 28 missing components    |
| 05 low lifetime  | 13 noises           | 21 contaminated   | 29 hydraulical           |
| 06 worn out      | 14 vibration        | 22 bad contact    | 30 electrical            |
| 07 dirt          | 15 miscellaneous    | 23 temperature    | 31 reinspection required |

- |                                     |                          |                          |                          |                          |                          |
|-------------------------------------|--------------------------|--------------------------|--------------------------|--------------------------|--------------------------|
| 4614 cover for rotating wave        | <input type="checkbox"/> | <input type="checkbox"/> | <input type="checkbox"/> | <input type="checkbox"/> | <input type="checkbox"/> |
| 4616 cover for chains               | <input type="checkbox"/> | <input type="checkbox"/> | <input type="checkbox"/> | <input type="checkbox"/> | <input type="checkbox"/> |
| 4617 cover for shift cylinder       | <input type="checkbox"/> | <input type="checkbox"/> | <input type="checkbox"/> | <input type="checkbox"/> | <input type="checkbox"/> |
| 4618 cover for moving parts         | <input type="checkbox"/> | <input type="checkbox"/> | <input type="checkbox"/> | <input type="checkbox"/> | <input type="checkbox"/> |
| 4619 cover for the exhaust pipe     | <input type="checkbox"/> | <input type="checkbox"/> | <input type="checkbox"/> | <input type="checkbox"/> | <input type="checkbox"/> |
| <b>4700 electrical system</b>       |                          |                          |                          |                          |                          |
| 4701 function of actuator component | <input type="checkbox"/> | <input type="checkbox"/> | <input type="checkbox"/> | <input type="checkbox"/> | <input type="checkbox"/> |
| 4702 emergency stop function        | <input type="checkbox"/> | <input type="checkbox"/> | <input type="checkbox"/> | <input type="checkbox"/> | <input type="checkbox"/> |
| 4703 ground connections             | <input type="checkbox"/> | <input type="checkbox"/> | <input type="checkbox"/> | <input type="checkbox"/> | <input type="checkbox"/> |
| 4704 cables and wiring harness      | <input type="checkbox"/> | <input type="checkbox"/> | <input type="checkbox"/> | <input type="checkbox"/> | <input type="checkbox"/> |
| 4705 temperature switch             | <input type="checkbox"/> | <input type="checkbox"/> | <input type="checkbox"/> | <input type="checkbox"/> | <input type="checkbox"/> |
| <b>4800 outrigger - system</b>      |                          |                          |                          |                          |                          |
| 4801 transportation lock            | <input type="checkbox"/> | <input type="checkbox"/> | <input type="checkbox"/> | <input type="checkbox"/> | <input type="checkbox"/> |
| 4802 locking device                 | <input type="checkbox"/> | <input type="checkbox"/> | <input type="checkbox"/> | <input type="checkbox"/> | <input type="checkbox"/> |
| 4803 backing plate                  | <input type="checkbox"/> | <input type="checkbox"/> | <input type="checkbox"/> | <input type="checkbox"/> | <input type="checkbox"/> |

- |  |                          |                          |                          |                          |                          |
|--|--------------------------|--------------------------|--------------------------|--------------------------|--------------------------|
| 4804 jack cylinder connections               | <input type="checkbox"/> | <input type="checkbox"/> | <input type="checkbox"/> | <input type="checkbox"/> | <input type="checkbox"/> |
| 4805 pressure adjustment of jack cylinder    | <input type="checkbox"/> | <input type="checkbox"/> | <input type="checkbox"/> | <input type="checkbox"/> | <input type="checkbox"/> |
| <b>4900 miscellaneous</b>                    |                          |                          |                          |                          |                          |
| 4901 additional assembled part from operator | <input type="checkbox"/> | <input type="checkbox"/> | <input type="checkbox"/> | <input type="checkbox"/> | <input type="checkbox"/> |
| 4902 changes through operator                | <input type="checkbox"/> | <input type="checkbox"/> | <input type="checkbox"/> | <input type="checkbox"/> | <input type="checkbox"/> |

**Competent inspector:**

Date: \_\_\_\_\_

Name: \_\_\_\_\_

Signature: \_\_\_\_\_  
(stamp)

**Customer:**

Signature: \_\_\_\_\_  
(stamp)

**This test report is filed into the test book**

# Inspection report for concrete booms

Inspection report -Nr:	Machine-Nr	Hours of operation:
		Concrete output m <sup>3</sup> :
Company:	Post code:	City:
Boom Type:	Boom Nr.	NL      WV

**Proof - Result of the Tests**

without defects	defects	reinspection required	shut down
<input type="checkbox"/>	<input type="checkbox"/>	<input type="checkbox"/>	<input type="checkbox"/>

Reinspection until date: .....

**Error code:**

- |                  |                     |                   |                          |
|------------------|---------------------|-------------------|--------------------------|
| 00 no objections | 08 corrosion        | 16 porous         | 24 deformation           |
| 01 cracks        | 09 lacquer failures | 17 burned through | 25 bear movement         |
| 02 broken        | 10 fraying          | 18 not fixed      | 26 lubrication           |
| 03 leaky         | 11 scratched        | 19 clomp          | 27 readability           |
| 04 no function   | 12 bendet           | 20 sawing         | 28 missing components    |
| 05 low lifetime  | 13 noises           | 21 contaminated   | 29 hydraulical           |
| 06 worn out      | 14 vibration        | 22 bad contact    | 30 electrical            |
| 07 dirt          | 15 miscellaneous    | 23 temperature    | 31 reinspection required |

<p><b>100 documents</b></p> <p>101 instruction manual    <input type="checkbox"/> <input type="checkbox"/> <input type="checkbox"/> <input type="checkbox"/> <input type="checkbox"/> <input type="checkbox"/></p> <p>102 spare parts list      <input type="checkbox"/> <input type="checkbox"/> <input type="checkbox"/> <input type="checkbox"/> <input type="checkbox"/> <input type="checkbox"/></p> <p><b>200 sub frame</b></p> <p>201 frame connection cpl.    <input type="checkbox"/> <input type="checkbox"/> <input type="checkbox"/> <input type="checkbox"/> <input type="checkbox"/> <input type="checkbox"/></p> <p><b>300 outrigger front R+L</b></p> <p>301 transportation safety device    <input type="checkbox"/> <input type="checkbox"/> <input type="checkbox"/> <input type="checkbox"/> <input type="checkbox"/> <input type="checkbox"/></p> <p>302 outrigger                    <input type="checkbox"/> <input type="checkbox"/> <input type="checkbox"/> <input type="checkbox"/> <input type="checkbox"/> <input type="checkbox"/></p> <p>303 extension box                <input type="checkbox"/> <input type="checkbox"/> <input type="checkbox"/> <input type="checkbox"/> <input type="checkbox"/> <input type="checkbox"/></p> <p>304 locking device                <input type="checkbox"/> <input type="checkbox"/> <input type="checkbox"/> <input type="checkbox"/> <input type="checkbox"/> <input type="checkbox"/></p> <p>305 slewing bearing              <input type="checkbox"/> <input type="checkbox"/> <input type="checkbox"/> <input type="checkbox"/> <input type="checkbox"/> <input type="checkbox"/></p> <p>306 turn locking device          <input type="checkbox"/> <input type="checkbox"/> <input type="checkbox"/> <input type="checkbox"/> <input type="checkbox"/> <input type="checkbox"/></p> <p>307 support safeguard          <input type="checkbox"/> <input type="checkbox"/> <input type="checkbox"/> <input type="checkbox"/> <input type="checkbox"/> <input type="checkbox"/></p> <p>308 support plate                 <input type="checkbox"/> <input type="checkbox"/> <input type="checkbox"/> <input type="checkbox"/> <input type="checkbox"/> <input type="checkbox"/></p> <p>309 fixing of jack cylinder      <input type="checkbox"/> <input type="checkbox"/> <input type="checkbox"/> <input type="checkbox"/> <input type="checkbox"/> <input type="checkbox"/></p> <p>310 jack cylinder                 <input type="checkbox"/> <input type="checkbox"/> <input type="checkbox"/> <input type="checkbox"/> <input type="checkbox"/> <input type="checkbox"/></p>	<p>311 swing cylinder                <input type="checkbox"/> <input type="checkbox"/> <input type="checkbox"/> <input type="checkbox"/> <input type="checkbox"/> <input type="checkbox"/></p> <p>312 telescopic-cylinder          <input type="checkbox"/> <input type="checkbox"/> <input type="checkbox"/> <input type="checkbox"/> <input type="checkbox"/> <input type="checkbox"/></p> <p>313 pressure adjustment         <input type="checkbox"/> <input type="checkbox"/> <input type="checkbox"/> <input type="checkbox"/> <input type="checkbox"/> <input type="checkbox"/></p> <p><b>400 outrigger rear L+R</b></p> <p>401 transportation safety device    <input type="checkbox"/> <input type="checkbox"/> <input type="checkbox"/> <input type="checkbox"/> <input type="checkbox"/> <input type="checkbox"/></p> <p>402 outrigger                      <input type="checkbox"/> <input type="checkbox"/> <input type="checkbox"/> <input type="checkbox"/> <input type="checkbox"/> <input type="checkbox"/></p> <p>403 extension box                 <input type="checkbox"/> <input type="checkbox"/> <input type="checkbox"/> <input type="checkbox"/> <input type="checkbox"/> <input type="checkbox"/></p> <p>405 locking device                 <input type="checkbox"/> <input type="checkbox"/> <input type="checkbox"/> <input type="checkbox"/> <input type="checkbox"/> <input type="checkbox"/></p> <p><b>Notes:</b></p> <hr/> <hr/> <hr/> <hr/> <hr/> <hr/>
---	---

# Inspection report for concrete booms

Inspection report Nr: \_\_\_\_\_ Boom type: \_\_\_\_\_ Machine-Nr: \_\_\_\_\_

**Error code:**

- |                  |                     |                   |                          |
|------------------|---------------------|-------------------|--------------------------|
| 00 no objections | 08 corrosion        | 16 porous         | 24 deformation           |
| 01 cracks        | 09 lacquer failures | 17 burned through | 25 bear movement         |
| 02 broken        | 10 fraying          | 18 not fixed      | 26 lubrication           |
| 03 leaky         | 11 scratched        | 19 clomp          | 27 readability           |
| 04 no function   | 12 bendet           | 20 sawing         | 28 missing components    |
| 05 low lifetime  | 13 noises           | 21 contaminated   | 29 hydraulical           |
| 06 worn out      | 14 vibration        | 22 bad contact    | 30 electrical            |
| 07 dirt          | 15 miscellaneous    | 23 temperature    | 31 reinspection required |

<p>406 slewing bearing <input type="checkbox"/> <input type="checkbox"/> <input type="checkbox"/> <input type="checkbox"/> <input type="checkbox"/></p> <p>407 turn locking device <input type="checkbox"/> <input type="checkbox"/> <input type="checkbox"/> <input type="checkbox"/> <input type="checkbox"/></p> <p>408 support safeguard <input type="checkbox"/> <input type="checkbox"/> <input type="checkbox"/> <input type="checkbox"/> <input type="checkbox"/></p> <p>409 support plate <input type="checkbox"/> <input type="checkbox"/> <input type="checkbox"/> <input type="checkbox"/> <input type="checkbox"/></p> <p>410 fixing of jack cylinder <input type="checkbox"/> <input type="checkbox"/> <input type="checkbox"/> <input type="checkbox"/> <input type="checkbox"/></p> <p>411 jack cylinder <input type="checkbox"/> <input type="checkbox"/> <input type="checkbox"/> <input type="checkbox"/> <input type="checkbox"/></p> <p>412 swing cylinder <input type="checkbox"/> <input type="checkbox"/> <input type="checkbox"/> <input type="checkbox"/> <input type="checkbox"/></p> <p>413 telescopic cylinder <input type="checkbox"/> <input type="checkbox"/> <input type="checkbox"/> <input type="checkbox"/> <input type="checkbox"/></p> <p><b>500 pedestal</b></p> <p>501 pedestal mounting <input type="checkbox"/> <input type="checkbox"/> <input type="checkbox"/> <input type="checkbox"/> <input type="checkbox"/></p> <p>502 sub frame <input type="checkbox"/> <input type="checkbox"/> <input type="checkbox"/> <input type="checkbox"/> <input type="checkbox"/></p> <p>503 truck frame <input type="checkbox"/> <input type="checkbox"/> <input type="checkbox"/> <input type="checkbox"/> <input type="checkbox"/></p> <p>504 pedestal (structure) <input type="checkbox"/> <input type="checkbox"/> <input type="checkbox"/> <input type="checkbox"/> <input type="checkbox"/></p> <p>505 boom valve without leaking <input type="checkbox"/> <input type="checkbox"/> <input type="checkbox"/> <input type="checkbox"/> <input type="checkbox"/></p> <p>506 boom rest <input type="checkbox"/> <input type="checkbox"/> <input type="checkbox"/> <input type="checkbox"/> <input type="checkbox"/></p> <p>507 transportation safety device <input type="checkbox"/> <input type="checkbox"/> <input type="checkbox"/> <input type="checkbox"/> <input type="checkbox"/></p> <p>508 hydraulic line <input type="checkbox"/> <input type="checkbox"/> <input type="checkbox"/> <input type="checkbox"/> <input type="checkbox"/></p> <p><b>600 slewing head with ball pivot</b></p> <p>601 slewing head <input type="checkbox"/> <input type="checkbox"/> <input type="checkbox"/> <input type="checkbox"/> <input type="checkbox"/></p> <p>602 ball pivot ring <input type="checkbox"/> <input type="checkbox"/> <input type="checkbox"/> <input type="checkbox"/> <input type="checkbox"/></p> <p>603 mounting ball pivot ring <input type="checkbox"/> <input type="checkbox"/> <input type="checkbox"/> <input type="checkbox"/> <input type="checkbox"/></p> <p>604 drive pinion <input type="checkbox"/> <input type="checkbox"/> <input type="checkbox"/> <input type="checkbox"/> <input type="checkbox"/></p>	<p>605 slewing drive mounting <input type="checkbox"/> <input type="checkbox"/> <input type="checkbox"/> <input type="checkbox"/> <input type="checkbox"/></p> <p>606 slewing stop device <input type="checkbox"/> <input type="checkbox"/> <input type="checkbox"/> <input type="checkbox"/> <input type="checkbox"/></p> <p>607 slewing drive (tooth backlash) <input type="checkbox"/> <input type="checkbox"/> <input type="checkbox"/> <input type="checkbox"/> <input type="checkbox"/></p> <p>608 slewing drive <input type="checkbox"/> <input type="checkbox"/> <input type="checkbox"/> <input type="checkbox"/> <input type="checkbox"/></p> <p>609 brake function <input type="checkbox"/> <input type="checkbox"/> <input type="checkbox"/> <input type="checkbox"/> <input type="checkbox"/></p> <p>610 speed <input type="checkbox"/> <input type="checkbox"/> <input type="checkbox"/> <input type="checkbox"/> <input type="checkbox"/></p> <p>611 pressure setting <input type="checkbox"/> <input type="checkbox"/> <input type="checkbox"/> <input type="checkbox"/> <input type="checkbox"/></p> <p>612 hydraulic lines <input type="checkbox"/> <input type="checkbox"/> <input type="checkbox"/> <input type="checkbox"/> <input type="checkbox"/></p> <p><b>700 slewing head with slewing column</b></p> <p>701 slewing head <input type="checkbox"/> <input type="checkbox"/> <input type="checkbox"/> <input type="checkbox"/> <input type="checkbox"/></p> <p>702 slewing column bearing <input type="checkbox"/> <input type="checkbox"/> <input type="checkbox"/> <input type="checkbox"/> <input type="checkbox"/></p> <p>703 slewing drive (tooth backlash) <input type="checkbox"/> <input type="checkbox"/> <input type="checkbox"/> <input type="checkbox"/> <input type="checkbox"/></p> <p>704 speed <input type="checkbox"/> <input type="checkbox"/> <input type="checkbox"/> <input type="checkbox"/> <input type="checkbox"/></p> <p>705 pressure settings <input type="checkbox"/> <input type="checkbox"/> <input type="checkbox"/> <input type="checkbox"/> <input type="checkbox"/></p> <p>706 hydraulic lines <input type="checkbox"/> <input type="checkbox"/> <input type="checkbox"/> <input type="checkbox"/> <input type="checkbox"/></p> <p>707 swivel cylinder <input type="checkbox"/> <input type="checkbox"/> <input type="checkbox"/> <input type="checkbox"/> <input type="checkbox"/></p> <p>Notes:</p> <hr/> <hr/> <hr/> <hr/>
---	---

# Inspection report for concrete booms

Inspection report Nr: \_\_\_\_\_ Boom type: \_\_\_\_\_ Machine-Nr: \_\_\_\_\_

**Error code:**

- |                  |                     |                   |                          |
|------------------|---------------------|-------------------|--------------------------|
| 00 no objections | 08 corrosion        | 16 porous         | 24 deformation           |
| 01 cracks        | 09 lacquer failures | 17 burned through | 25 bear movement         |
| 02 broken        | 10 fraying          | 18 not fixed      | 26 lubrication           |
| 03 leaky         | 11 scratched        | 19 clemp          | 27 readability           |
| 04 no function   | 12 bendet           | 20 sawing         | 28 missing components    |
| 05 low lifetime  | 13 noises           | 21 contaminated   | 29 hydraulical           |
| 06 worn out      | 14 vibration        | 22 bad contact    | 30 electrical            |
| 07 dirt          | 15 miscellaneous    | 23 temperature    | 31 reinspection required |

<p><b>800 boom</b></p> <p>801 „Arm 1“ <input type="checkbox"/> <input type="checkbox"/> <input type="checkbox"/> <input type="checkbox"/> <input type="checkbox"/></p> <p>802 bracket conveying line <input type="checkbox"/> <input type="checkbox"/> <input type="checkbox"/> <input type="checkbox"/> <input type="checkbox"/></p> <p>803 Drop hook <input type="checkbox"/> <input type="checkbox"/> <input type="checkbox"/> <input type="checkbox"/> <input type="checkbox"/></p> <p>804 „Arm 2“ <input type="checkbox"/> <input type="checkbox"/> <input type="checkbox"/> <input type="checkbox"/> <input type="checkbox"/></p> <p>805 bracket conveying line <input type="checkbox"/> <input type="checkbox"/> <input type="checkbox"/> <input type="checkbox"/> <input type="checkbox"/></p> <p>806 Drop hook <input type="checkbox"/> <input type="checkbox"/> <input type="checkbox"/> <input type="checkbox"/> <input type="checkbox"/></p> <p>807 „Arm 3“ <input type="checkbox"/> <input type="checkbox"/> <input type="checkbox"/> <input type="checkbox"/> <input type="checkbox"/></p> <p>808 bracket conveying line <input type="checkbox"/> <input type="checkbox"/> <input type="checkbox"/> <input type="checkbox"/> <input type="checkbox"/></p> <p>809 guidance and interlock of the arm <input type="checkbox"/> <input type="checkbox"/> <input type="checkbox"/> <input type="checkbox"/> <input type="checkbox"/></p> <p>810 „Arm 4“ <input type="checkbox"/> <input type="checkbox"/> <input type="checkbox"/> <input type="checkbox"/> <input type="checkbox"/></p> <p>811 bracket conveying line <input type="checkbox"/> <input type="checkbox"/> <input type="checkbox"/> <input type="checkbox"/> <input type="checkbox"/></p> <p>812 guidance and interlock of the arm <input type="checkbox"/> <input type="checkbox"/> <input type="checkbox"/> <input type="checkbox"/> <input type="checkbox"/></p> <p>813 „Arm 5“ <input type="checkbox"/> <input type="checkbox"/> <input type="checkbox"/> <input type="checkbox"/> <input type="checkbox"/></p> <p>814 bracket conveying line <input type="checkbox"/> <input type="checkbox"/> <input type="checkbox"/> <input type="checkbox"/> <input type="checkbox"/></p> <p>815 guidance and interlock of the arm <input type="checkbox"/> <input type="checkbox"/> <input type="checkbox"/> <input type="checkbox"/> <input type="checkbox"/></p> <p><b>900 joint „A“</b></p> <p>901 boom <input type="checkbox"/> <input type="checkbox"/> <input type="checkbox"/> <input type="checkbox"/> <input type="checkbox"/></p> <p>902 link lever <input type="checkbox"/> <input type="checkbox"/> <input type="checkbox"/> <input type="checkbox"/> <input type="checkbox"/></p> <p>903 forcing rod <input type="checkbox"/> <input type="checkbox"/> <input type="checkbox"/> <input type="checkbox"/> <input type="checkbox"/></p> <p>904 pin <input type="checkbox"/> <input type="checkbox"/> <input type="checkbox"/> <input type="checkbox"/> <input type="checkbox"/></p> <p>905 cylinder <input type="checkbox"/> <input type="checkbox"/> <input type="checkbox"/> <input type="checkbox"/> <input type="checkbox"/></p>	<p>906 boom speed <input type="checkbox"/> <input type="checkbox"/> <input type="checkbox"/> <input type="checkbox"/> <input type="checkbox"/></p> <p>907 pressure settings <input type="checkbox"/> <input type="checkbox"/> <input type="checkbox"/> <input type="checkbox"/> <input type="checkbox"/></p> <p>908 hydraulic lines <input type="checkbox"/> <input type="checkbox"/> <input type="checkbox"/> <input type="checkbox"/> <input type="checkbox"/></p> <p>909 load holding valve (piston side) <input type="checkbox"/> <input type="checkbox"/> <input type="checkbox"/> <input type="checkbox"/> <input type="checkbox"/></p> <p>910 load holding valve (rod side) <input type="checkbox"/> <input type="checkbox"/> <input type="checkbox"/> <input type="checkbox"/> <input type="checkbox"/></p> <p><b>1000 joint „B“</b></p> <p>1001 boom <input type="checkbox"/> <input type="checkbox"/> <input type="checkbox"/> <input type="checkbox"/> <input type="checkbox"/></p> <p>1002 link lever <input type="checkbox"/> <input type="checkbox"/> <input type="checkbox"/> <input type="checkbox"/> <input type="checkbox"/></p> <p>1003 forcing rod <input type="checkbox"/> <input type="checkbox"/> <input type="checkbox"/> <input type="checkbox"/> <input type="checkbox"/></p> <p>1004 pin <input type="checkbox"/> <input type="checkbox"/> <input type="checkbox"/> <input type="checkbox"/> <input type="checkbox"/></p> <p>1005 cylinder <input type="checkbox"/> <input type="checkbox"/> <input type="checkbox"/> <input type="checkbox"/> <input type="checkbox"/></p> <p>1006 boom speed <input type="checkbox"/> <input type="checkbox"/> <input type="checkbox"/> <input type="checkbox"/> <input type="checkbox"/></p> <p>1007 pressure settings <input type="checkbox"/> <input type="checkbox"/> <input type="checkbox"/> <input type="checkbox"/> <input type="checkbox"/></p> <p>1008 hydraulic lines <input type="checkbox"/> <input type="checkbox"/> <input type="checkbox"/> <input type="checkbox"/> <input type="checkbox"/></p> <p>1009 load holding valve (piston side) <input type="checkbox"/> <input type="checkbox"/> <input type="checkbox"/> <input type="checkbox"/> <input type="checkbox"/></p> <p>1010 load holding valve (rod side) <input type="checkbox"/> <input type="checkbox"/> <input type="checkbox"/> <input type="checkbox"/> <input type="checkbox"/></p> <p>Notes:</p> <hr/> <hr/> <hr/> <hr/>
--	---

# Inspection report for concrete booms

Inspection report Nr: \_\_\_\_\_ Boom type: \_\_\_\_\_ Machine-Nr: \_\_\_\_\_

Error code:			
00 no objections	08 corrosion	16 porous	24 deformation
01 cracks	09 lacquer failures	17 burned through	25 bear movement
02 broken	10 fraying	18 not fixed	26 lubrication
03 leaky	11 scratched	19 clomp	27 readability
04 no function	12 bendet	20 sawing	28 missing components
05 low lifetime	13 noises	21 contaminated	29 hydraulical
06 worn out	14 vibration	22 bad contact	30 electrical
07 dirt	15 miscellaneous	23 temperature	31 reinspection required

<p><b>1100 joint "C"</b></p> <p>1101 boom <input type="checkbox"/> <input type="checkbox"/> <input type="checkbox"/> <input type="checkbox"/> <input type="checkbox"/></p> <p>1102 link lever <input type="checkbox"/> <input type="checkbox"/> <input type="checkbox"/> <input type="checkbox"/> <input type="checkbox"/></p> <p>1103 forcing rod <input type="checkbox"/> <input type="checkbox"/> <input type="checkbox"/> <input type="checkbox"/> <input type="checkbox"/></p> <p>1104 pin <input type="checkbox"/> <input type="checkbox"/> <input type="checkbox"/> <input type="checkbox"/> <input type="checkbox"/></p> <p>1105 cylinder <input type="checkbox"/> <input type="checkbox"/> <input type="checkbox"/> <input type="checkbox"/> <input type="checkbox"/></p> <p>1106 boom speed <input type="checkbox"/> <input type="checkbox"/> <input type="checkbox"/> <input type="checkbox"/> <input type="checkbox"/></p> <p>1107 pressure settings <input type="checkbox"/> <input type="checkbox"/> <input type="checkbox"/> <input type="checkbox"/> <input type="checkbox"/></p> <p>1108 hydraulic lines <input type="checkbox"/> <input type="checkbox"/> <input type="checkbox"/> <input type="checkbox"/> <input type="checkbox"/></p> <p>1109 load holding valve (piston side) <input type="checkbox"/> <input type="checkbox"/> <input type="checkbox"/> <input type="checkbox"/> <input type="checkbox"/></p> <p>1110 load holding valve (rod side) <input type="checkbox"/> <input type="checkbox"/> <input type="checkbox"/> <input type="checkbox"/> <input type="checkbox"/></p> <p><b>1200 joint "D"</b></p> <p>1201 boom <input type="checkbox"/> <input type="checkbox"/> <input type="checkbox"/> <input type="checkbox"/> <input type="checkbox"/></p> <p>1202 link lever <input type="checkbox"/> <input type="checkbox"/> <input type="checkbox"/> <input type="checkbox"/> <input type="checkbox"/></p> <p>1203 forcing rod <input type="checkbox"/> <input type="checkbox"/> <input type="checkbox"/> <input type="checkbox"/> <input type="checkbox"/></p> <p>1204 pin <input type="checkbox"/> <input type="checkbox"/> <input type="checkbox"/> <input type="checkbox"/> <input type="checkbox"/></p> <p>1205 cylinder <input type="checkbox"/> <input type="checkbox"/> <input type="checkbox"/> <input type="checkbox"/> <input type="checkbox"/></p> <p>1206 boom speed <input type="checkbox"/> <input type="checkbox"/> <input type="checkbox"/> <input type="checkbox"/> <input type="checkbox"/></p> <p>1207 pressure settings <input type="checkbox"/> <input type="checkbox"/> <input type="checkbox"/> <input type="checkbox"/> <input type="checkbox"/></p> <p>1208 hydraulic lines <input type="checkbox"/> <input type="checkbox"/> <input type="checkbox"/> <input type="checkbox"/> <input type="checkbox"/></p> <p>1209 load holding valve (piston side) <input type="checkbox"/> <input type="checkbox"/> <input type="checkbox"/> <input type="checkbox"/> <input type="checkbox"/></p> <p>1210 load holding valve (rod side) <input type="checkbox"/> <input type="checkbox"/> <input type="checkbox"/> <input type="checkbox"/> <input type="checkbox"/></p>	<p><b>1300 joint „E“</b></p> <p>1301 boom <input type="checkbox"/> <input type="checkbox"/> <input type="checkbox"/> <input type="checkbox"/> <input type="checkbox"/></p> <p>1302 link lever <input type="checkbox"/> <input type="checkbox"/> <input type="checkbox"/> <input type="checkbox"/> <input type="checkbox"/></p> <p>1303 forcing rod <input type="checkbox"/> <input type="checkbox"/> <input type="checkbox"/> <input type="checkbox"/> <input type="checkbox"/></p> <p>1304 pin <input type="checkbox"/> <input type="checkbox"/> <input type="checkbox"/> <input type="checkbox"/> <input type="checkbox"/></p> <p>1305 cylinder <input type="checkbox"/> <input type="checkbox"/> <input type="checkbox"/> <input type="checkbox"/> <input type="checkbox"/></p> <p>1306 boom speed <input type="checkbox"/> <input type="checkbox"/> <input type="checkbox"/> <input type="checkbox"/> <input type="checkbox"/></p> <p>1307 pressure settings <input type="checkbox"/> <input type="checkbox"/> <input type="checkbox"/> <input type="checkbox"/> <input type="checkbox"/></p> <p>1308 hydraulic lines <input type="checkbox"/> <input type="checkbox"/> <input type="checkbox"/> <input type="checkbox"/> <input type="checkbox"/></p> <p>1309 load holding valve (piston side) <input type="checkbox"/> <input type="checkbox"/> <input type="checkbox"/> <input type="checkbox"/> <input type="checkbox"/></p> <p>1310 load holding valve (rod side) <input type="checkbox"/> <input type="checkbox"/> <input type="checkbox"/> <input type="checkbox"/> <input type="checkbox"/></p> <p><b>1400 concrete delivery line</b></p> <p>1401 assembly of delivery line DN <input type="checkbox"/> <input type="checkbox"/> <input type="checkbox"/> <input type="checkbox"/> <input type="checkbox"/></p> <p>1402 end hose DN+length <input type="checkbox"/> <input type="checkbox"/> <input type="checkbox"/> <input type="checkbox"/> <input type="checkbox"/></p> <p>1403 delivery line DN <input type="checkbox"/> <input type="checkbox"/> <input type="checkbox"/> <input type="checkbox"/> <input type="checkbox"/></p> <p>1404 rotating joints of - delivery line <input type="checkbox"/> <input type="checkbox"/> <input type="checkbox"/> <input type="checkbox"/> <input type="checkbox"/></p> <p>1405 locking pin of the coupling <input type="checkbox"/> <input type="checkbox"/> <input type="checkbox"/> <input type="checkbox"/> <input type="checkbox"/></p> <p>Notes:</p> <hr/> <hr/> <hr/>
---	--

## Inspection report for concrete booms

Page 5-5

Inspection report Nr: \_\_\_\_\_ Boom type: \_\_\_\_\_ Machine-Nr: \_\_\_\_\_

**Error code:**

- |                  |                     |                   |                          |
|------------------|---------------------|-------------------|--------------------------|
| 00 no objections | 08 corrosion        | 16 porous         | 24 deformation           |
| 01 cracks        | 09 lacquer failures | 17 burned through | 25 bear movement         |
| 02 broken        | 10 fraying          | 18 not fixed      | 26 lubrication           |
| 03 leaky         | 11 scratched        | 19 clomp          | 27 readability           |
| 04 no function   | 12 bendet           | 20 sawing         | 28 missing components    |
| 05 low lifetime  | 13 noises           | 21 contaminated   | 29 hydraulical           |
| 06 worn out      | 14 vibration        | 22 bad contact    | 30 electrical            |
| 07 dirt          | 15 miscellaneous    | 23 temperature    | 31 reinspection required |

1406 end hose safety device

1407 reducer

1408 gate elbow, elbow 6"

**1500 hydraulic system and hydraulic valves**

1501 Pressure relief valve

1502 pressure settings

1503 hydraulic lines

1504 hand operating-  
(function)

1505 boom control valve

1506 hydraulic pump

**1600 electric equipment**

1601 remote control  
(functions)

1602 emergency stop  
(function)

1603 switch for outrigger  
function

1604 switch for boom  
function

1605 wiring harness

1606 central lubrication

**1700 sticker sets**

1701 safety hints

1702 description

1703 operating

1704 short operating  
instruction

1705 sticker „don't use  
the boom as crane“

1706 sticker „guideline  
operating with boom-  
and concrete pump“

1707 name plate

1708 sticker „danger  
high voltage“

**Competent inspector:**

Date: \_\_\_\_\_

Name: \_\_\_\_\_

Signature: \_\_\_\_\_  
(stamp)

**Customer:**

Signature: \_\_\_\_\_  
(stamp)

# Inspection report for concrete pump

Inspection report Nr:	Machine-Nr:	Hours of operation:
		Concrete output m <sup>3</sup> :
Company:	Post code:	City:

NL	WV
----	----

**Proof – Result of the tests**

without defects	defects	reinspection required	shut down
<input type="checkbox"/>	<input type="checkbox"/>	<input type="checkbox"/>	<input type="checkbox"/>

Reinspection until date: .....

**Error code:**

- |                  |                     |                   |                          |
|------------------|---------------------|-------------------|--------------------------|
| 00 no objections | 08 corrosion        | 16 porous         | 24 deformation           |
| 01 cracks        | 09 lacquer failures | 17 burned through | 25 bear movement         |
| 02 broken        | 10 fraying          | 18 not fixed      | 26 lubrication           |
| 03 leaky         | 11 scratched        | 19 clamp          | 27 readability           |
| 04 no fuction    | 12 bendet           | 20 sawing         | 28 missing components    |
| 05 low livetime  | 13 noises           | 21 contaminated   | 29 hydraulical           |
| 06 worn out      | 14 vibration        | 22 bad contact    | 30 electrical            |
| 07 dirt          | 15 miscellaneous    | 23 temperature    | 31 reinspection required |

**2000 documents**

2001 operating manual	<input type="checkbox"/>	<input type="checkbox"/>	<input type="checkbox"/>	<input type="checkbox"/>	<input type="checkbox"/>
2002 spare parts list	<input type="checkbox"/>	<input type="checkbox"/>	<input type="checkbox"/>	<input type="checkbox"/>	<input type="checkbox"/>
<b>2100 drive assembly</b>					
2101 coupling and flange	<input type="checkbox"/>	<input type="checkbox"/>	<input type="checkbox"/>	<input type="checkbox"/>	<input type="checkbox"/>
2200 gear box	<input type="checkbox"/>	<input type="checkbox"/>	<input type="checkbox"/>	<input type="checkbox"/>	<input type="checkbox"/>
2300 hydraulic pump (main)	<input type="checkbox"/>	<input type="checkbox"/>	<input type="checkbox"/>	<input type="checkbox"/>	<input type="checkbox"/>
2400 oil-tank	<input type="checkbox"/>	<input type="checkbox"/>	<input type="checkbox"/>	<input type="checkbox"/>	<input type="checkbox"/>
2500 drive shaft	<input type="checkbox"/>	<input type="checkbox"/>	<input type="checkbox"/>	<input type="checkbox"/>	<input type="checkbox"/>

**2700 hydraulic control system**

2701 pressure relief valve	<input type="checkbox"/>	<input type="checkbox"/>	<input type="checkbox"/>	<input type="checkbox"/>	<input type="checkbox"/>
2702 pressure setting	<input type="checkbox"/>	<input type="checkbox"/>	<input type="checkbox"/>	<input type="checkbox"/>	<input type="checkbox"/>
2703 hydraulic line	<input type="checkbox"/>	<input type="checkbox"/>	<input type="checkbox"/>	<input type="checkbox"/>	<input type="checkbox"/>
2704 mechanical operation by hand	<input type="checkbox"/>	<input type="checkbox"/>	<input type="checkbox"/>	<input type="checkbox"/>	<input type="checkbox"/>
2800 oil-cooler	<input type="checkbox"/>	<input type="checkbox"/>	<input type="checkbox"/>	<input type="checkbox"/>	<input type="checkbox"/>
2900 accumulator	<input type="checkbox"/>	<input type="checkbox"/>	<input type="checkbox"/>	<input type="checkbox"/>	<input type="checkbox"/>
2901 proofs of the required tests according to accumulator regulation	<input type="checkbox"/>	<input type="checkbox"/>	<input type="checkbox"/>	<input type="checkbox"/>	<input type="checkbox"/>
2902 pressure gauge	<input type="checkbox"/>	<input type="checkbox"/>	<input type="checkbox"/>	<input type="checkbox"/>	<input type="checkbox"/>

Notes:



# Inspection report for concrete pump

Inspection report Nr: \_\_\_\_\_ Machine-Nr: \_\_\_\_\_

**Error code:**

- |                  |                     |                   |                          |
|------------------|---------------------|-------------------|--------------------------|
| 00 no objections | 08 corrosion        | 16 porous         | 24 deformation           |
| 01 cracks        | 09 lacquer failures | 17 burned through | 25 bear movement         |
| 02 broken        | 10 fraying          | 18 not fixed      | 26 lubrication           |
| 03 leaky         | 11 scratched        | 19 clomp          | 27 readability           |
| 04 no function   | 12 bendet           | 20 sawing         | 28 missing components    |
| 05 low lifetime  | 13 noises           | 21 contaminated   | 29 hydraulical           |
| 06 worn out      | 14 vibration        | 22 bad contact    | 30 electrical            |
| 07 dirt          | 15 miscellaneous    | 23 temperature    | 31 reinspection required |

<p><b>3000 central lubrication</b>    <input type="checkbox"/> <input type="checkbox"/> <input type="checkbox"/> <input type="checkbox"/> <input type="checkbox"/></p> <p><b>3100 hydraulic motor</b>    <input type="checkbox"/> <input type="checkbox"/> <input type="checkbox"/> <input type="checkbox"/> <input type="checkbox"/></p> <p><b>3200 hydraulic lines</b>    <input type="checkbox"/> <input type="checkbox"/> <input type="checkbox"/> <input type="checkbox"/> <input type="checkbox"/></p> <p><b>3300 air compressor</b>    <input type="checkbox"/> <input type="checkbox"/> <input type="checkbox"/> <input type="checkbox"/> <input type="checkbox"/></p> <p><b>3400 control panel</b>    <input type="checkbox"/> <input type="checkbox"/> <input type="checkbox"/> <input type="checkbox"/> <input type="checkbox"/></p> <p><b>3500 concrete pump</b>    <input type="checkbox"/> <input type="checkbox"/> <input type="checkbox"/> <input type="checkbox"/> <input type="checkbox"/></p> <p><b>3700 S-valve</b>    <input type="checkbox"/> <input type="checkbox"/> <input type="checkbox"/> <input type="checkbox"/> <input type="checkbox"/></p> <p><b>3800 hopper</b>    <input type="checkbox"/> <input type="checkbox"/> <input type="checkbox"/> <input type="checkbox"/> <input type="checkbox"/></p> <p><b>4100 sub frame</b>    <input type="checkbox"/> <input type="checkbox"/> <input type="checkbox"/> <input type="checkbox"/> <input type="checkbox"/></p> <p><b>4200 water tank</b>    <input type="checkbox"/> <input type="checkbox"/> <input type="checkbox"/> <input type="checkbox"/> <input type="checkbox"/></p> <p><b>4300 axle</b>    <input type="checkbox"/> <input type="checkbox"/> <input type="checkbox"/> <input type="checkbox"/> <input type="checkbox"/></p> <p><b>4400 water pump</b>    <input type="checkbox"/> <input type="checkbox"/> <input type="checkbox"/> <input type="checkbox"/> <input type="checkbox"/></p> <p><b>4500 vibrator</b>    <input type="checkbox"/> <input type="checkbox"/> <input type="checkbox"/> <input type="checkbox"/> <input type="checkbox"/></p>	<p><b>4600 safety guards, equipment</b></p> <p><b>4601 stair</b>    <input type="checkbox"/> <input type="checkbox"/> <input type="checkbox"/> <input type="checkbox"/> <input type="checkbox"/></p> <p><b>4602 safety for stair</b>    <input type="checkbox"/> <input type="checkbox"/> <input type="checkbox"/> <input type="checkbox"/> <input type="checkbox"/></p> <p><b>4603 handrail</b>    <input type="checkbox"/> <input type="checkbox"/> <input type="checkbox"/> <input type="checkbox"/> <input type="checkbox"/></p> <p><b>4604 hopper grid (fixing device)</b>    <input type="checkbox"/> <input type="checkbox"/> <input type="checkbox"/> <input type="checkbox"/> <input type="checkbox"/></p> <p><b>4606 distance of grid rods</b>    <input type="checkbox"/> <input type="checkbox"/> <input type="checkbox"/> <input type="checkbox"/> <input type="checkbox"/></p> <p><b>4607 distance from grid to agitator</b>    <input type="checkbox"/> <input type="checkbox"/> <input type="checkbox"/> <input type="checkbox"/> <input type="checkbox"/></p> <p><b>4609 agitator have to stop if grid is open</b>    <input type="checkbox"/> <input type="checkbox"/> <input type="checkbox"/> <input type="checkbox"/> <input type="checkbox"/></p> <p><b>4610 accumulator have to dump if grid is open</b>    <input type="checkbox"/> <input type="checkbox"/> <input type="checkbox"/> <input type="checkbox"/> <input type="checkbox"/></p> <p><b>4612 cleaning flap hopper</b>    <input type="checkbox"/> <input type="checkbox"/> <input type="checkbox"/> <input type="checkbox"/> <input type="checkbox"/></p> <p><b>4613 safety grid into water box</b>    <input type="checkbox"/> <input type="checkbox"/> <input type="checkbox"/> <input type="checkbox"/> <input type="checkbox"/></p>
--	---

Notes:

# Inspection report for concrete pump

Inspection report Nr: \_\_\_\_\_ Machine-Nr: \_\_\_\_\_

**Error code:**

- |                  |                     |                   |                          |
|------------------|---------------------|-------------------|--------------------------|
| 00 no objections | 08 corrosion        | 16 porous         | 24 deformation           |
| 01 cracks        | 09 lacquer failures | 17 burned through | 25 bear movement         |
| 02 broken        | 10 fraying          | 18 not fixed      | 26 lubrication           |
| 03 leaky         | 11 scratched        | 19 clomp          | 27 readability           |
| 04 no function   | 12 bendet           | 20 sawing         | 28 missing components    |
| 05 low lifetime  | 13 noises           | 21 contaminated   | 29 hydraulical           |
| 06 worn out      | 14 vibration        | 22 bad contact    | 30 electrical            |
| 07 dirt          | 15 miscellaneous    | 23 temperature    | 31 reinspection required |

<p>4614 cover for rotating wave <input type="checkbox"/> <input type="checkbox"/> <input type="checkbox"/> <input type="checkbox"/> <input type="checkbox"/></p> <p>4616 cover for chains <input type="checkbox"/> <input type="checkbox"/> <input type="checkbox"/> <input type="checkbox"/> <input type="checkbox"/></p> <p>4617 cover for shift cylinder <input type="checkbox"/> <input type="checkbox"/> <input type="checkbox"/> <input type="checkbox"/> <input type="checkbox"/></p> <p>4618 cover for moving parts <input type="checkbox"/> <input type="checkbox"/> <input type="checkbox"/> <input type="checkbox"/> <input type="checkbox"/></p> <p>4619 cover for the exhaust pipe <input type="checkbox"/> <input type="checkbox"/> <input type="checkbox"/> <input type="checkbox"/> <input type="checkbox"/></p> <p><b>4700 electrical system</b></p> <p>4701 function of actuator component <input type="checkbox"/> <input type="checkbox"/> <input type="checkbox"/> <input type="checkbox"/> <input type="checkbox"/></p> <p>4702 emergency stop function <input type="checkbox"/> <input type="checkbox"/> <input type="checkbox"/> <input type="checkbox"/> <input type="checkbox"/></p> <p>4703 ground connections <input type="checkbox"/> <input type="checkbox"/> <input type="checkbox"/> <input type="checkbox"/> <input type="checkbox"/></p> <p>4704 cables and wiring harness <input type="checkbox"/> <input type="checkbox"/> <input type="checkbox"/> <input type="checkbox"/> <input type="checkbox"/></p> <p>4705 temperature switch <input type="checkbox"/> <input type="checkbox"/> <input type="checkbox"/> <input type="checkbox"/> <input type="checkbox"/></p> <p><b>4800 outrigger - system</b></p> <p>4801 transportation lock <input type="checkbox"/> <input type="checkbox"/> <input type="checkbox"/> <input type="checkbox"/> <input type="checkbox"/></p> <p>4802 locking device <input type="checkbox"/> <input type="checkbox"/> <input type="checkbox"/> <input type="checkbox"/> <input type="checkbox"/></p> <p>4803 backing plate <input type="checkbox"/> <input type="checkbox"/> <input type="checkbox"/> <input type="checkbox"/> <input type="checkbox"/></p>	<p>4804 jack cylinder connections <input type="checkbox"/> <input type="checkbox"/> <input type="checkbox"/> <input type="checkbox"/> <input type="checkbox"/></p> <p>4805 pressure adjustment of jack cylinder <input type="checkbox"/> <input type="checkbox"/> <input type="checkbox"/> <input type="checkbox"/> <input type="checkbox"/></p> <p><b>4900 miscellaneous</b></p> <p>4901 additional assembled part from operator <input type="checkbox"/> <input type="checkbox"/> <input type="checkbox"/> <input type="checkbox"/> <input type="checkbox"/></p> <p>4902 changes through operator <input type="checkbox"/> <input type="checkbox"/> <input type="checkbox"/> <input type="checkbox"/> <input type="checkbox"/></p> <p><b>Competent inspector:</b></p> <p>Date: _____</p> <p>Name: _____</p> <p>Signature: _____ (stamp)</p> <p><b>Customer:</b></p> <p>Signature: _____ (stamp)</p> <p style="text-align: center;"><b>This test report is filed into the test book</b></p>
---	---

# Inspection report for concrete booms

Inspection report -Nr:	Machine-Nr	Hours of operation:
		Concrete output m <sup>3</sup> :
Company:	Post code:	City:
Boom Type:	Boom Nr.	NL                      WV

**Proof - Result of the Tests**

without defects	defects	reinspection required	shut down
<input type="checkbox"/>	<input type="checkbox"/>	<input type="checkbox"/>	<input type="checkbox"/>

Reinspection until date:.....

**Error code:**

- |                  |                     |                   |                          |
|------------------|---------------------|-------------------|--------------------------|
| 00 no objections | 08 corrosion        | 16 porous         | 24 deformation           |
| 01 cracks        | 09 lacquer failures | 17 burned through | 25 bear movement         |
| 02 broken        | 10 fraying          | 18 not fixed      | 26 lubrication           |
| 03 leaky         | 11 scratched        | 19 clomp          | 27 readability           |
| 04 no function   | 12 bendet           | 20 sawing         | 28 missing components    |
| 05 low lifetime  | 13 noises           | 21 contaminated   | 29 hydraulic             |
| 06 worn out      | 14 vibration        | 22 bad contact    | 30 electrical            |
| 07 dirt          | 15 miscellaneous    | 23 temperature    | 31 reinspection required |

<p><b>100 documents</b></p> <p>101 instruction manual    <input type="checkbox"/> <input type="checkbox"/> <input type="checkbox"/> <input type="checkbox"/> <input type="checkbox"/></p> <p>102 spare parts list      <input type="checkbox"/> <input type="checkbox"/> <input type="checkbox"/> <input type="checkbox"/> <input type="checkbox"/></p> <p><b>200 sub frame</b></p> <p>201 frame connection cpl.    <input type="checkbox"/> <input type="checkbox"/> <input type="checkbox"/> <input type="checkbox"/> <input type="checkbox"/></p> <p><b>300 outrigger front R+L</b></p> <p>301 transportation safety device    <input type="checkbox"/> <input type="checkbox"/> <input type="checkbox"/> <input type="checkbox"/> <input type="checkbox"/></p> <p>302 outrigger                    <input type="checkbox"/> <input type="checkbox"/> <input type="checkbox"/> <input type="checkbox"/> <input type="checkbox"/></p> <p>303 extension box              <input type="checkbox"/> <input type="checkbox"/> <input type="checkbox"/> <input type="checkbox"/> <input type="checkbox"/></p> <p>304 locking device              <input type="checkbox"/> <input type="checkbox"/> <input type="checkbox"/> <input type="checkbox"/> <input type="checkbox"/></p> <p>305 slewing bearing            <input type="checkbox"/> <input type="checkbox"/> <input type="checkbox"/> <input type="checkbox"/> <input type="checkbox"/></p> <p>306 turn locking device        <input type="checkbox"/> <input type="checkbox"/> <input type="checkbox"/> <input type="checkbox"/> <input type="checkbox"/></p> <p>307 support safeguard         <input type="checkbox"/> <input type="checkbox"/> <input type="checkbox"/> <input type="checkbox"/> <input type="checkbox"/></p> <p>308 support plate              <input type="checkbox"/> <input type="checkbox"/> <input type="checkbox"/> <input type="checkbox"/> <input type="checkbox"/></p> <p>309 fixing of jack cylinder    <input type="checkbox"/> <input type="checkbox"/> <input type="checkbox"/> <input type="checkbox"/> <input type="checkbox"/></p> <p>310 jack cylinder               <input type="checkbox"/> <input type="checkbox"/> <input type="checkbox"/> <input type="checkbox"/> <input type="checkbox"/></p>	<p>311 swing cylinder            <input type="checkbox"/> <input type="checkbox"/> <input type="checkbox"/> <input type="checkbox"/> <input type="checkbox"/></p> <p>312 telescopic-cylinder      <input type="checkbox"/> <input type="checkbox"/> <input type="checkbox"/> <input type="checkbox"/> <input type="checkbox"/></p> <p>313 pressure adjustment      <input type="checkbox"/> <input type="checkbox"/> <input type="checkbox"/> <input type="checkbox"/> <input type="checkbox"/></p> <p><b>400 outrigger rear L+R</b></p> <p>401 transportation safety device    <input type="checkbox"/> <input type="checkbox"/> <input type="checkbox"/> <input type="checkbox"/> <input type="checkbox"/></p> <p>402 outrigger                    <input type="checkbox"/> <input type="checkbox"/> <input type="checkbox"/> <input type="checkbox"/> <input type="checkbox"/></p> <p>403 extension box              <input type="checkbox"/> <input type="checkbox"/> <input type="checkbox"/> <input type="checkbox"/> <input type="checkbox"/></p> <p>405 locking device              <input type="checkbox"/> <input type="checkbox"/> <input type="checkbox"/> <input type="checkbox"/> <input type="checkbox"/></p> <p>Notes:</p> <hr/> <hr/> <hr/> <hr/> <hr/>
--	--

# Inspection report for concrete booms

Inspection report Nr: \_\_\_\_\_ Boom type: \_\_\_\_\_ Machine-Nr: \_\_\_\_\_

<b>Error code:</b>	<b>08 corrosion</b>	<b>16 porous</b>	<b>24 deformation</b>
<b>00 no objections</b>	<b>09 lacquer failures</b>	<b>17 burned through</b>	<b>25 bear movement</b>
<b>01 cracks</b>	<b>10 fraying</b>	<b>18 not fixed</b>	<b>26 lubrication</b>
<b>02 broken</b>	<b>11 scratched</b>	<b>19 clomp</b>	<b>27 readability</b>
<b>03 leaky</b>	<b>12 bendet</b>	<b>20 sawing</b>	<b>28 missing components</b>
<b>04 no function</b>	<b>13 noises</b>	<b>21 contaminated</b>	<b>29 hydraulical</b>
<b>05 low lifetime</b>	<b>14 vibration</b>	<b>22 bad contact</b>	<b>30 electrical</b>
<b>06 worn out</b>	<b>15 miscellaneous</b>	<b>23 temperature</b>	<b>31 reinspection required</b>
<b>07 dirt</b>			

<table border="0" style="width: 100%;"> <tr> <td style="width: 30%;">406 slewing bearing</td> <td style="width: 20%; text-align: center;"><input type="checkbox"/></td> <td style="width: 20%; text-align: center;"><input type="checkbox"/></td> <td style="width: 20%; text-align: center;"><input type="checkbox"/></td> <td style="width: 20%; text-align: center;"><input type="checkbox"/></td> <td style="width: 20%; text-align: center;"><input type="checkbox"/></td> </tr> <tr> <td>407 turn locking device</td> <td style="text-align: center;"><input type="checkbox"/></td> <td style="text-align: center;"><input type="checkbox"/></td> <td style="text-align: center;"><input type="checkbox"/></td> <td style="text-align: center;"><input type="checkbox"/></td> <td style="text-align: center;"><input type="checkbox"/></td> </tr> <tr> <td>408 support safeguard</td> <td style="text-align: center;"><input type="checkbox"/></td> <td style="text-align: center;"><input type="checkbox"/></td> <td style="text-align: center;"><input type="checkbox"/></td> <td style="text-align: center;"><input type="checkbox"/></td> <td style="text-align: center;"><input type="checkbox"/></td> </tr> <tr> <td>409 support plate</td> <td style="text-align: center;"><input type="checkbox"/></td> <td style="text-align: center;"><input type="checkbox"/></td> <td style="text-align: center;"><input type="checkbox"/></td> <td style="text-align: center;"><input type="checkbox"/></td> <td style="text-align: center;"><input type="checkbox"/></td> </tr> <tr> <td>410 fixing of jack cylinder</td> <td style="text-align: center;"><input type="checkbox"/></td> <td style="text-align: center;"><input type="checkbox"/></td> <td style="text-align: center;"><input type="checkbox"/></td> <td style="text-align: center;"><input type="checkbox"/></td> <td style="text-align: center;"><input type="checkbox"/></td> </tr> <tr> <td>411 jack cylinder</td> <td style="text-align: center;"><input type="checkbox"/></td> <td style="text-align: center;"><input type="checkbox"/></td> <td style="text-align: center;"><input type="checkbox"/></td> <td style="text-align: center;"><input type="checkbox"/></td> <td style="text-align: center;"><input type="checkbox"/></td> </tr> <tr> <td>412 swing cylinder</td> <td style="text-align: center;"><input type="checkbox"/></td> <td style="text-align: center;"><input type="checkbox"/></td> <td style="text-align: center;"><input type="checkbox"/></td> <td style="text-align: center;"><input type="checkbox"/></td> <td style="text-align: center;"><input type="checkbox"/></td> </tr> <tr> <td>413 telescopic cylinder</td> <td style="text-align: center;"><input type="checkbox"/></td> <td style="text-align: center;"><input type="checkbox"/></td> <td style="text-align: center;"><input type="checkbox"/></td> <td style="text-align: center;"><input type="checkbox"/></td> <td style="text-align: center;"><input type="checkbox"/></td> </tr> <tr> <td colspan="6"><b>500 pedestal</b></td> </tr> <tr> <td>501 pedestal mounting</td> <td style="text-align: center;"><input type="checkbox"/></td> <td style="text-align: center;"><input type="checkbox"/></td> <td style="text-align: center;"><input type="checkbox"/></td> <td style="text-align: center;"><input type="checkbox"/></td> <td style="text-align: center;"><input type="checkbox"/></td> </tr> <tr> <td>502 sub frame</td> <td style="text-align: center;"><input type="checkbox"/></td> <td style="text-align: center;"><input type="checkbox"/></td> <td style="text-align: center;"><input type="checkbox"/></td> <td style="text-align: center;"><input type="checkbox"/></td> <td style="text-align: center;"><input type="checkbox"/></td> </tr> <tr> <td>503 truck frame</td> <td style="text-align: center;"><input type="checkbox"/></td> <td style="text-align: center;"><input type="checkbox"/></td> <td style="text-align: center;"><input type="checkbox"/></td> <td style="text-align: center;"><input type="checkbox"/></td> <td style="text-align: center;"><input type="checkbox"/></td> </tr> <tr> <td>504 pedestal (structure)</td> <td style="text-align: center;"><input type="checkbox"/></td> <td style="text-align: center;"><input type="checkbox"/></td> <td style="text-align: center;"><input type="checkbox"/></td> <td style="text-align: center;"><input type="checkbox"/></td> <td style="text-align: center;"><input type="checkbox"/></td> </tr> <tr> <td>505 boom valve without leaking</td> <td style="text-align: center;"><input type="checkbox"/></td> <td style="text-align: center;"><input type="checkbox"/></td> <td style="text-align: center;"><input type="checkbox"/></td> <td style="text-align: center;"><input type="checkbox"/></td> <td style="text-align: center;"><input type="checkbox"/></td> </tr> <tr> <td>506 boom rest</td> <td style="text-align: center;"><input type="checkbox"/></td> <td style="text-align: center;"><input type="checkbox"/></td> <td style="text-align: center;"><input type="checkbox"/></td> <td style="text-align: center;"><input type="checkbox"/></td> <td style="text-align: center;"><input type="checkbox"/></td> </tr> <tr> <td>507 transportation safety device</td> <td style="text-align: center;"><input type="checkbox"/></td> <td style="text-align: center;"><input type="checkbox"/></td> <td style="text-align: center;"><input type="checkbox"/></td> <td style="text-align: center;"><input type="checkbox"/></td> <td style="text-align: center;"><input type="checkbox"/></td> </tr> <tr> <td>508 hydraulic line</td> <td style="text-align: center;"><input type="checkbox"/></td> <td style="text-align: center;"><input type="checkbox"/></td> <td style="text-align: center;"><input type="checkbox"/></td> <td style="text-align: center;"><input type="checkbox"/></td> <td style="text-align: center;"><input type="checkbox"/></td> </tr> <tr> <td colspan="6"><b>600 slewing head with ball pivot</b></td> </tr> <tr> <td>601 slewing head</td> <td style="text-align: center;"><input type="checkbox"/></td> <td style="text-align: center;"><input type="checkbox"/></td> <td style="text-align: center;"><input type="checkbox"/></td> <td style="text-align: center;"><input type="checkbox"/></td> <td style="text-align: center;"><input type="checkbox"/></td> </tr> <tr> <td>602 ball pivot ring</td> <td style="text-align: center;"><input type="checkbox"/></td> <td style="text-align: center;"><input type="checkbox"/></td> <td style="text-align: center;"><input type="checkbox"/></td> <td style="text-align: center;"><input type="checkbox"/></td> <td style="text-align: center;"><input type="checkbox"/></td> </tr> <tr> <td>603 mounting ball pivot ring</td> <td style="text-align: center;"><input type="checkbox"/></td> <td style="text-align: center;"><input type="checkbox"/></td> <td style="text-align: center;"><input type="checkbox"/></td> <td style="text-align: center;"><input type="checkbox"/></td> <td style="text-align: center;"><input type="checkbox"/></td> </tr> <tr> <td>604 drive pinion</td> <td style="text-align: center;"><input type="checkbox"/></td> <td style="text-align: center;"><input type="checkbox"/></td> <td style="text-align: center;"><input type="checkbox"/></td> <td style="text-align: center;"><input type="checkbox"/></td> <td style="text-align: center;"><input type="checkbox"/></td> </tr> </table>	406 slewing bearing	<input type="checkbox"/>	<input type="checkbox"/>	<input type="checkbox"/>	<input type="checkbox"/>	<input type="checkbox"/>	407 turn locking device	<input type="checkbox"/>	<input type="checkbox"/>	<input type="checkbox"/>	<input type="checkbox"/>	<input type="checkbox"/>	408 support safeguard	<input type="checkbox"/>	<input type="checkbox"/>	<input type="checkbox"/>	<input type="checkbox"/>	<input type="checkbox"/>	409 support plate	<input type="checkbox"/>	<input type="checkbox"/>	<input type="checkbox"/>	<input type="checkbox"/>	<input type="checkbox"/>	410 fixing of jack cylinder	<input type="checkbox"/>	<input type="checkbox"/>	<input type="checkbox"/>	<input type="checkbox"/>	<input type="checkbox"/>	411 jack cylinder	<input type="checkbox"/>	<input type="checkbox"/>	<input type="checkbox"/>	<input type="checkbox"/>	<input type="checkbox"/>	412 swing cylinder	<input type="checkbox"/>	<input type="checkbox"/>	<input type="checkbox"/>	<input type="checkbox"/>	<input type="checkbox"/>	413 telescopic cylinder	<input type="checkbox"/>	<input type="checkbox"/>	<input type="checkbox"/>	<input type="checkbox"/>	<input type="checkbox"/>	<b>500 pedestal</b>						501 pedestal mounting	<input type="checkbox"/>	<input type="checkbox"/>	<input type="checkbox"/>	<input type="checkbox"/>	<input type="checkbox"/>	502 sub frame	<input type="checkbox"/>	<input type="checkbox"/>	<input type="checkbox"/>	<input type="checkbox"/>	<input type="checkbox"/>	503 truck frame	<input type="checkbox"/>	<input type="checkbox"/>	<input type="checkbox"/>	<input type="checkbox"/>	<input type="checkbox"/>	504 pedestal (structure)	<input type="checkbox"/>	<input type="checkbox"/>	<input type="checkbox"/>	<input type="checkbox"/>	<input type="checkbox"/>	505 boom valve without leaking	<input type="checkbox"/>	<input type="checkbox"/>	<input type="checkbox"/>	<input type="checkbox"/>	<input type="checkbox"/>	506 boom rest	<input type="checkbox"/>	<input type="checkbox"/>	<input type="checkbox"/>	<input type="checkbox"/>	<input type="checkbox"/>	507 transportation safety device	<input type="checkbox"/>	<input type="checkbox"/>	<input type="checkbox"/>	<input type="checkbox"/>	<input type="checkbox"/>	508 hydraulic line	<input type="checkbox"/>	<input type="checkbox"/>	<input type="checkbox"/>	<input type="checkbox"/>	<input type="checkbox"/>	<b>600 slewing head with ball pivot</b>						601 slewing head	<input type="checkbox"/>	<input type="checkbox"/>	<input type="checkbox"/>	<input type="checkbox"/>	<input type="checkbox"/>	602 ball pivot ring	<input type="checkbox"/>	<input type="checkbox"/>	<input type="checkbox"/>	<input type="checkbox"/>	<input type="checkbox"/>	603 mounting ball pivot ring	<input type="checkbox"/>	<input type="checkbox"/>	<input type="checkbox"/>	<input type="checkbox"/>	<input type="checkbox"/>	604 drive pinion	<input type="checkbox"/>	<input type="checkbox"/>	<input type="checkbox"/>	<input type="checkbox"/>	<input type="checkbox"/>	<table border="0" style="width: 100%;"> <tr> <td style="width: 70%;">605 slewing drive mounting</td> <td style="width: 5%; text-align: center;"><input type="checkbox"/></td> <td style="width: 5%; text-align: center;"><input type="checkbox"/></td> <td style="width: 5%; text-align: center;"><input type="checkbox"/></td> <td style="width: 5%; text-align: center;"><input type="checkbox"/></td> <td style="width: 5%; text-align: center;"><input type="checkbox"/></td> </tr> <tr> <td>606 slewing stop device</td> <td style="text-align: center;"><input type="checkbox"/></td> <td style="text-align: center;"><input type="checkbox"/></td> <td style="text-align: center;"><input type="checkbox"/></td> <td style="text-align: center;"><input type="checkbox"/></td> <td style="text-align: center;"><input type="checkbox"/></td> </tr> <tr> <td>607 slewing drive (tooth backlash)</td> <td style="text-align: center;"><input type="checkbox"/></td> <td style="text-align: center;"><input type="checkbox"/></td> <td style="text-align: center;"><input type="checkbox"/></td> <td style="text-align: center;"><input type="checkbox"/></td> <td style="text-align: center;"><input type="checkbox"/></td> </tr> <tr> <td>608 slewing drive</td> <td style="text-align: center;"><input type="checkbox"/></td> <td style="text-align: center;"><input type="checkbox"/></td> <td style="text-align: center;"><input type="checkbox"/></td> <td style="text-align: center;"><input type="checkbox"/></td> <td style="text-align: center;"><input type="checkbox"/></td> </tr> <tr> <td>609 brake function</td> <td style="text-align: center;"><input type="checkbox"/></td> <td style="text-align: center;"><input type="checkbox"/></td> <td style="text-align: center;"><input type="checkbox"/></td> <td style="text-align: center;"><input type="checkbox"/></td> <td style="text-align: center;"><input type="checkbox"/></td> </tr> <tr> <td>610 speed</td> <td style="text-align: center;"><input type="checkbox"/></td> <td style="text-align: center;"><input type="checkbox"/></td> <td style="text-align: center;"><input type="checkbox"/></td> <td style="text-align: center;"><input type="checkbox"/></td> <td style="text-align: center;"><input type="checkbox"/></td> </tr> <tr> <td>611 pressure setting</td> <td style="text-align: center;"><input type="checkbox"/></td> <td style="text-align: center;"><input type="checkbox"/></td> <td style="text-align: center;"><input type="checkbox"/></td> <td style="text-align: center;"><input type="checkbox"/></td> <td style="text-align: center;"><input type="checkbox"/></td> </tr> <tr> <td>612 hydraulic lines</td> <td style="text-align: center;"><input type="checkbox"/></td> <td style="text-align: center;"><input type="checkbox"/></td> <td style="text-align: center;"><input type="checkbox"/></td> <td style="text-align: center;"><input type="checkbox"/></td> <td style="text-align: center;"><input type="checkbox"/></td> </tr> <tr> <td colspan="6"><b>700 slewing head with slewing column</b></td> </tr> <tr> <td>701 slewing head</td> <td style="text-align: center;"><input type="checkbox"/></td> <td style="text-align: center;"><input type="checkbox"/></td> <td style="text-align: center;"><input type="checkbox"/></td> <td style="text-align: center;"><input type="checkbox"/></td> <td style="text-align: center;"><input type="checkbox"/></td> </tr> <tr> <td>702 slewing column bearing</td> <td style="text-align: center;"><input type="checkbox"/></td> <td style="text-align: center;"><input type="checkbox"/></td> <td style="text-align: center;"><input type="checkbox"/></td> <td style="text-align: center;"><input type="checkbox"/></td> <td style="text-align: center;"><input type="checkbox"/></td> </tr> <tr> <td>703 slewing drive (tooth backlash)</td> <td style="text-align: center;"><input type="checkbox"/></td> <td style="text-align: center;"><input type="checkbox"/></td> <td style="text-align: center;"><input type="checkbox"/></td> <td style="text-align: center;"><input type="checkbox"/></td> <td style="text-align: center;"><input type="checkbox"/></td> </tr> <tr> <td>704 speed</td> <td style="text-align: center;"><input type="checkbox"/></td> <td style="text-align: center;"><input type="checkbox"/></td> <td style="text-align: center;"><input type="checkbox"/></td> <td style="text-align: center;"><input type="checkbox"/></td> <td style="text-align: center;"><input type="checkbox"/></td> </tr> <tr> <td>705 pressure settings</td> <td style="text-align: center;"><input type="checkbox"/></td> <td style="text-align: center;"><input type="checkbox"/></td> <td style="text-align: center;"><input type="checkbox"/></td> <td style="text-align: center;"><input type="checkbox"/></td> <td style="text-align: center;"><input type="checkbox"/></td> </tr> <tr> <td>706 hydraulic lines</td> <td style="text-align: center;"><input type="checkbox"/></td> <td style="text-align: center;"><input type="checkbox"/></td> <td style="text-align: center;"><input type="checkbox"/></td> <td style="text-align: center;"><input type="checkbox"/></td> <td style="text-align: center;"><input type="checkbox"/></td> </tr> <tr> <td>707 swivel cylinder</td> <td style="text-align: center;"><input type="checkbox"/></td> <td style="text-align: center;"><input type="checkbox"/></td> <td style="text-align: center;"><input type="checkbox"/></td> <td style="text-align: center;"><input type="checkbox"/></td> <td style="text-align: center;"><input type="checkbox"/></td> </tr> </table> <p>Notes:</p> <hr/> <hr/> <hr/> <hr/>	605 slewing drive mounting	<input type="checkbox"/>	<input type="checkbox"/>	<input type="checkbox"/>	<input type="checkbox"/>	<input type="checkbox"/>	606 slewing stop device	<input type="checkbox"/>	<input type="checkbox"/>	<input type="checkbox"/>	<input type="checkbox"/>	<input type="checkbox"/>	607 slewing drive (tooth backlash)	<input type="checkbox"/>	<input type="checkbox"/>	<input type="checkbox"/>	<input type="checkbox"/>	<input type="checkbox"/>	608 slewing drive	<input type="checkbox"/>	<input type="checkbox"/>	<input type="checkbox"/>	<input type="checkbox"/>	<input type="checkbox"/>	609 brake function	<input type="checkbox"/>	<input type="checkbox"/>	<input type="checkbox"/>	<input type="checkbox"/>	<input type="checkbox"/>	610 speed	<input type="checkbox"/>	<input type="checkbox"/>	<input type="checkbox"/>	<input type="checkbox"/>	<input type="checkbox"/>	611 pressure setting	<input type="checkbox"/>	<input type="checkbox"/>	<input type="checkbox"/>	<input type="checkbox"/>	<input type="checkbox"/>	612 hydraulic lines	<input type="checkbox"/>	<input type="checkbox"/>	<input type="checkbox"/>	<input type="checkbox"/>	<input type="checkbox"/>	<b>700 slewing head with slewing column</b>						701 slewing head	<input type="checkbox"/>	<input type="checkbox"/>	<input type="checkbox"/>	<input type="checkbox"/>	<input type="checkbox"/>	702 slewing column bearing	<input type="checkbox"/>	<input type="checkbox"/>	<input type="checkbox"/>	<input type="checkbox"/>	<input type="checkbox"/>	703 slewing drive (tooth backlash)	<input type="checkbox"/>	<input type="checkbox"/>	<input type="checkbox"/>	<input type="checkbox"/>	<input type="checkbox"/>	704 speed	<input type="checkbox"/>	<input type="checkbox"/>	<input type="checkbox"/>	<input type="checkbox"/>	<input type="checkbox"/>	705 pressure settings	<input type="checkbox"/>	<input type="checkbox"/>	<input type="checkbox"/>	<input type="checkbox"/>	<input type="checkbox"/>	706 hydraulic lines	<input type="checkbox"/>	<input type="checkbox"/>	<input type="checkbox"/>	<input type="checkbox"/>	<input type="checkbox"/>	707 swivel cylinder	<input type="checkbox"/>	<input type="checkbox"/>	<input type="checkbox"/>	<input type="checkbox"/>	<input type="checkbox"/>
406 slewing bearing	<input type="checkbox"/>	<input type="checkbox"/>	<input type="checkbox"/>	<input type="checkbox"/>	<input type="checkbox"/>																																																																																																																																																																																																																																
407 turn locking device	<input type="checkbox"/>	<input type="checkbox"/>	<input type="checkbox"/>	<input type="checkbox"/>	<input type="checkbox"/>																																																																																																																																																																																																																																
408 support safeguard	<input type="checkbox"/>	<input type="checkbox"/>	<input type="checkbox"/>	<input type="checkbox"/>	<input type="checkbox"/>																																																																																																																																																																																																																																
409 support plate	<input type="checkbox"/>	<input type="checkbox"/>	<input type="checkbox"/>	<input type="checkbox"/>	<input type="checkbox"/>																																																																																																																																																																																																																																
410 fixing of jack cylinder	<input type="checkbox"/>	<input type="checkbox"/>	<input type="checkbox"/>	<input type="checkbox"/>	<input type="checkbox"/>																																																																																																																																																																																																																																
411 jack cylinder	<input type="checkbox"/>	<input type="checkbox"/>	<input type="checkbox"/>	<input type="checkbox"/>	<input type="checkbox"/>																																																																																																																																																																																																																																
412 swing cylinder	<input type="checkbox"/>	<input type="checkbox"/>	<input type="checkbox"/>	<input type="checkbox"/>	<input type="checkbox"/>																																																																																																																																																																																																																																
413 telescopic cylinder	<input type="checkbox"/>	<input type="checkbox"/>	<input type="checkbox"/>	<input type="checkbox"/>	<input type="checkbox"/>																																																																																																																																																																																																																																
<b>500 pedestal</b>																																																																																																																																																																																																																																					
501 pedestal mounting	<input type="checkbox"/>	<input type="checkbox"/>	<input type="checkbox"/>	<input type="checkbox"/>	<input type="checkbox"/>																																																																																																																																																																																																																																
502 sub frame	<input type="checkbox"/>	<input type="checkbox"/>	<input type="checkbox"/>	<input type="checkbox"/>	<input type="checkbox"/>																																																																																																																																																																																																																																
503 truck frame	<input type="checkbox"/>	<input type="checkbox"/>	<input type="checkbox"/>	<input type="checkbox"/>	<input type="checkbox"/>																																																																																																																																																																																																																																
504 pedestal (structure)	<input type="checkbox"/>	<input type="checkbox"/>	<input type="checkbox"/>	<input type="checkbox"/>	<input type="checkbox"/>																																																																																																																																																																																																																																
505 boom valve without leaking	<input type="checkbox"/>	<input type="checkbox"/>	<input type="checkbox"/>	<input type="checkbox"/>	<input type="checkbox"/>																																																																																																																																																																																																																																
506 boom rest	<input type="checkbox"/>	<input type="checkbox"/>	<input type="checkbox"/>	<input type="checkbox"/>	<input type="checkbox"/>																																																																																																																																																																																																																																
507 transportation safety device	<input type="checkbox"/>	<input type="checkbox"/>	<input type="checkbox"/>	<input type="checkbox"/>	<input type="checkbox"/>																																																																																																																																																																																																																																
508 hydraulic line	<input type="checkbox"/>	<input type="checkbox"/>	<input type="checkbox"/>	<input type="checkbox"/>	<input type="checkbox"/>																																																																																																																																																																																																																																
<b>600 slewing head with ball pivot</b>																																																																																																																																																																																																																																					
601 slewing head	<input type="checkbox"/>	<input type="checkbox"/>	<input type="checkbox"/>	<input type="checkbox"/>	<input type="checkbox"/>																																																																																																																																																																																																																																
602 ball pivot ring	<input type="checkbox"/>	<input type="checkbox"/>	<input type="checkbox"/>	<input type="checkbox"/>	<input type="checkbox"/>																																																																																																																																																																																																																																
603 mounting ball pivot ring	<input type="checkbox"/>	<input type="checkbox"/>	<input type="checkbox"/>	<input type="checkbox"/>	<input type="checkbox"/>																																																																																																																																																																																																																																
604 drive pinion	<input type="checkbox"/>	<input type="checkbox"/>	<input type="checkbox"/>	<input type="checkbox"/>	<input type="checkbox"/>																																																																																																																																																																																																																																
605 slewing drive mounting	<input type="checkbox"/>	<input type="checkbox"/>	<input type="checkbox"/>	<input type="checkbox"/>	<input type="checkbox"/>																																																																																																																																																																																																																																
606 slewing stop device	<input type="checkbox"/>	<input type="checkbox"/>	<input type="checkbox"/>	<input type="checkbox"/>	<input type="checkbox"/>																																																																																																																																																																																																																																
607 slewing drive (tooth backlash)	<input type="checkbox"/>	<input type="checkbox"/>	<input type="checkbox"/>	<input type="checkbox"/>	<input type="checkbox"/>																																																																																																																																																																																																																																
608 slewing drive	<input type="checkbox"/>	<input type="checkbox"/>	<input type="checkbox"/>	<input type="checkbox"/>	<input type="checkbox"/>																																																																																																																																																																																																																																
609 brake function	<input type="checkbox"/>	<input type="checkbox"/>	<input type="checkbox"/>	<input type="checkbox"/>	<input type="checkbox"/>																																																																																																																																																																																																																																
610 speed	<input type="checkbox"/>	<input type="checkbox"/>	<input type="checkbox"/>	<input type="checkbox"/>	<input type="checkbox"/>																																																																																																																																																																																																																																
611 pressure setting	<input type="checkbox"/>	<input type="checkbox"/>	<input type="checkbox"/>	<input type="checkbox"/>	<input type="checkbox"/>																																																																																																																																																																																																																																
612 hydraulic lines	<input type="checkbox"/>	<input type="checkbox"/>	<input type="checkbox"/>	<input type="checkbox"/>	<input type="checkbox"/>																																																																																																																																																																																																																																
<b>700 slewing head with slewing column</b>																																																																																																																																																																																																																																					
701 slewing head	<input type="checkbox"/>	<input type="checkbox"/>	<input type="checkbox"/>	<input type="checkbox"/>	<input type="checkbox"/>																																																																																																																																																																																																																																
702 slewing column bearing	<input type="checkbox"/>	<input type="checkbox"/>	<input type="checkbox"/>	<input type="checkbox"/>	<input type="checkbox"/>																																																																																																																																																																																																																																
703 slewing drive (tooth backlash)	<input type="checkbox"/>	<input type="checkbox"/>	<input type="checkbox"/>	<input type="checkbox"/>	<input type="checkbox"/>																																																																																																																																																																																																																																
704 speed	<input type="checkbox"/>	<input type="checkbox"/>	<input type="checkbox"/>	<input type="checkbox"/>	<input type="checkbox"/>																																																																																																																																																																																																																																
705 pressure settings	<input type="checkbox"/>	<input type="checkbox"/>	<input type="checkbox"/>	<input type="checkbox"/>	<input type="checkbox"/>																																																																																																																																																																																																																																
706 hydraulic lines	<input type="checkbox"/>	<input type="checkbox"/>	<input type="checkbox"/>	<input type="checkbox"/>	<input type="checkbox"/>																																																																																																																																																																																																																																
707 swivel cylinder	<input type="checkbox"/>	<input type="checkbox"/>	<input type="checkbox"/>	<input type="checkbox"/>	<input type="checkbox"/>																																																																																																																																																																																																																																

# Inspection report for concrete booms

Inspection report Nr: \_\_\_\_\_ Boom type: \_\_\_\_\_ Machine-Nr: \_\_\_\_\_

**Error code:**

- |                  |                     |                   |                          |
|------------------|---------------------|-------------------|--------------------------|
| 00 no objections | 08 corrosion        | 16 porous         | 24 deformation           |
| 01 cracks        | 09 lacquer failures | 17 burned through | 25 bear movement         |
| 02 broken        | 10 fraying          | 18 not fixed      | 26 lubrication           |
| 03 leaky         | 11 scratched        | 19 clomp          | 27 readability           |
| 04 no function   | 12 bendet           | 20 sawing         | 28 missing components    |
| 05 low lifetime  | 13 noises           | 21 contaminated   | 29 hydraulical           |
| 06 worn out      | 14 vibration        | 22 bad contact    | 30 electrical            |
| 07 dirt          | 15 miscellaneous    | 23 temperature    | 31 reinspection required |

<p><b>800 boom</b></p> <p>801 „Arm 1“ <input type="checkbox"/> <input type="checkbox"/> <input type="checkbox"/> <input type="checkbox"/> <input type="checkbox"/></p> <p>802 bracket conveying line <input type="checkbox"/> <input type="checkbox"/> <input type="checkbox"/> <input type="checkbox"/> <input type="checkbox"/></p> <p>803 Drop hook <input type="checkbox"/> <input type="checkbox"/> <input type="checkbox"/> <input type="checkbox"/> <input type="checkbox"/></p> <p>804 „Arm 2“ <input type="checkbox"/> <input type="checkbox"/> <input type="checkbox"/> <input type="checkbox"/> <input type="checkbox"/></p> <p>805 bracket conveying line <input type="checkbox"/> <input type="checkbox"/> <input type="checkbox"/> <input type="checkbox"/> <input type="checkbox"/></p> <p>806 Drop hook <input type="checkbox"/> <input type="checkbox"/> <input type="checkbox"/> <input type="checkbox"/> <input type="checkbox"/></p> <p>807 „Arm 3“ <input type="checkbox"/> <input type="checkbox"/> <input type="checkbox"/> <input type="checkbox"/> <input type="checkbox"/></p> <p>808 bracket conveying line <input type="checkbox"/> <input type="checkbox"/> <input type="checkbox"/> <input type="checkbox"/> <input type="checkbox"/></p> <p>809 guidance and interlock of the arm <input type="checkbox"/> <input type="checkbox"/> <input type="checkbox"/> <input type="checkbox"/> <input type="checkbox"/></p> <p>810 „Arm 4“ <input type="checkbox"/> <input type="checkbox"/> <input type="checkbox"/> <input type="checkbox"/> <input type="checkbox"/></p> <p>811 bracket conveying line <input type="checkbox"/> <input type="checkbox"/> <input type="checkbox"/> <input type="checkbox"/> <input type="checkbox"/></p> <p>812 guidance and interlock of the arm <input type="checkbox"/> <input type="checkbox"/> <input type="checkbox"/> <input type="checkbox"/> <input type="checkbox"/></p> <p>813 „Arm 5“ <input type="checkbox"/> <input type="checkbox"/> <input type="checkbox"/> <input type="checkbox"/> <input type="checkbox"/></p> <p>814 bracket conveying line <input type="checkbox"/> <input type="checkbox"/> <input type="checkbox"/> <input type="checkbox"/> <input type="checkbox"/></p> <p>815 guidance and interlock of the arm <input type="checkbox"/> <input type="checkbox"/> <input type="checkbox"/> <input type="checkbox"/> <input type="checkbox"/></p> <p><b>900 joint „A“</b></p> <p>901 boom <input type="checkbox"/> <input type="checkbox"/> <input type="checkbox"/> <input type="checkbox"/> <input type="checkbox"/></p> <p>902 link lever <input type="checkbox"/> <input type="checkbox"/> <input type="checkbox"/> <input type="checkbox"/> <input type="checkbox"/></p> <p>903 forcing rod <input type="checkbox"/> <input type="checkbox"/> <input type="checkbox"/> <input type="checkbox"/> <input type="checkbox"/></p> <p>904 pin <input type="checkbox"/> <input type="checkbox"/> <input type="checkbox"/> <input type="checkbox"/> <input type="checkbox"/></p> <p>905 cylinder <input type="checkbox"/> <input type="checkbox"/> <input type="checkbox"/> <input type="checkbox"/> <input type="checkbox"/></p>	<p>906 boom speed <input type="checkbox"/> <input type="checkbox"/> <input type="checkbox"/> <input type="checkbox"/> <input type="checkbox"/></p> <p>907 pressure settings <input type="checkbox"/> <input type="checkbox"/> <input type="checkbox"/> <input type="checkbox"/> <input type="checkbox"/></p> <p>908 hydraulic lines <input type="checkbox"/> <input type="checkbox"/> <input type="checkbox"/> <input type="checkbox"/> <input type="checkbox"/></p> <p>909 load holding valve (piston side) <input type="checkbox"/> <input type="checkbox"/> <input type="checkbox"/> <input type="checkbox"/> <input type="checkbox"/></p> <p>910 load holding valve (rod side) <input type="checkbox"/> <input type="checkbox"/> <input type="checkbox"/> <input type="checkbox"/> <input type="checkbox"/></p> <p><b>1000 joint „B“</b></p> <p>1001 boom <input type="checkbox"/> <input type="checkbox"/> <input type="checkbox"/> <input type="checkbox"/> <input type="checkbox"/></p> <p>1002 link lever <input type="checkbox"/> <input type="checkbox"/> <input type="checkbox"/> <input type="checkbox"/> <input type="checkbox"/></p> <p>1003 forcing rod <input type="checkbox"/> <input type="checkbox"/> <input type="checkbox"/> <input type="checkbox"/> <input type="checkbox"/></p> <p>1004 pin <input type="checkbox"/> <input type="checkbox"/> <input type="checkbox"/> <input type="checkbox"/> <input type="checkbox"/></p> <p>1005 cylinder <input type="checkbox"/> <input type="checkbox"/> <input type="checkbox"/> <input type="checkbox"/> <input type="checkbox"/></p> <p>1006 boom speed <input type="checkbox"/> <input type="checkbox"/> <input type="checkbox"/> <input type="checkbox"/> <input type="checkbox"/></p> <p>1007 pressure settings <input type="checkbox"/> <input type="checkbox"/> <input type="checkbox"/> <input type="checkbox"/> <input type="checkbox"/></p> <p>1008 hydraulic lines <input type="checkbox"/> <input type="checkbox"/> <input type="checkbox"/> <input type="checkbox"/> <input type="checkbox"/></p> <p>1009 load holding valve (piston side) <input type="checkbox"/> <input type="checkbox"/> <input type="checkbox"/> <input type="checkbox"/> <input type="checkbox"/></p> <p>1010 load holding valve (rod side) <input type="checkbox"/> <input type="checkbox"/> <input type="checkbox"/> <input type="checkbox"/> <input type="checkbox"/></p> <p>Notes:</p> <hr/> <hr/> <hr/> <hr/>
--	---

# Inspection report for concrete booms

Inspection report Nr: \_\_\_\_\_ Boom type: \_\_\_\_\_ Machine-Nr: \_\_\_\_\_

Error code:			
00 no objections	08 corrosion	16 porous	24 deformation
01 cracks	09 lacquer failures	17 burned through	25 bear movement
02 broken	10 fraying	18 not fixed	26 lubrication
03 leaky	11 scratched	19 clomp	27 readability
04 no function	12 bendet	20 sawing	28 missing components
05 low lifetime	13 noises	21 contaminated	29 hydraulic
06 worn out	14 vibration	22 bad contact	30 electrical
07 dirt	15 miscellaneous	23 temperature	31 reinspection required

<p><b>1100 joint "C"</b></p> <p>1101 boom <input type="checkbox"/> <input type="checkbox"/> <input type="checkbox"/> <input type="checkbox"/> <input type="checkbox"/></p> <p>1102 link lever <input type="checkbox"/> <input type="checkbox"/> <input type="checkbox"/> <input type="checkbox"/> <input type="checkbox"/></p> <p>1103 forcing rod <input type="checkbox"/> <input type="checkbox"/> <input type="checkbox"/> <input type="checkbox"/> <input type="checkbox"/></p> <p>1104 pin <input type="checkbox"/> <input type="checkbox"/> <input type="checkbox"/> <input type="checkbox"/> <input type="checkbox"/></p> <p>1105 cylinder <input type="checkbox"/> <input type="checkbox"/> <input type="checkbox"/> <input type="checkbox"/> <input type="checkbox"/></p> <p>1106 boom speed <input type="checkbox"/> <input type="checkbox"/> <input type="checkbox"/> <input type="checkbox"/> <input type="checkbox"/></p> <p>1107 pressure settings <input type="checkbox"/> <input type="checkbox"/> <input type="checkbox"/> <input type="checkbox"/> <input type="checkbox"/></p> <p>1108 hydraulic lines <input type="checkbox"/> <input type="checkbox"/> <input type="checkbox"/> <input type="checkbox"/> <input type="checkbox"/></p> <p>1109 load holding valve (piston side) <input type="checkbox"/> <input type="checkbox"/> <input type="checkbox"/> <input type="checkbox"/> <input type="checkbox"/></p> <p>1110 load holding valve (rod side) <input type="checkbox"/> <input type="checkbox"/> <input type="checkbox"/> <input type="checkbox"/> <input type="checkbox"/></p> <p><b>1200 joint "D"</b></p> <p>1201 boom <input type="checkbox"/> <input type="checkbox"/> <input type="checkbox"/> <input type="checkbox"/> <input type="checkbox"/></p> <p>1202 link lever <input type="checkbox"/> <input type="checkbox"/> <input type="checkbox"/> <input type="checkbox"/> <input type="checkbox"/></p> <p>1203 forcing rod <input type="checkbox"/> <input type="checkbox"/> <input type="checkbox"/> <input type="checkbox"/> <input type="checkbox"/></p> <p>1204 pin <input type="checkbox"/> <input type="checkbox"/> <input type="checkbox"/> <input type="checkbox"/> <input type="checkbox"/></p> <p>1205 cylinder <input type="checkbox"/> <input type="checkbox"/> <input type="checkbox"/> <input type="checkbox"/> <input type="checkbox"/></p> <p>1206 boom speed <input type="checkbox"/> <input type="checkbox"/> <input type="checkbox"/> <input type="checkbox"/> <input type="checkbox"/></p> <p>1207 pressure settings <input type="checkbox"/> <input type="checkbox"/> <input type="checkbox"/> <input type="checkbox"/> <input type="checkbox"/></p> <p>1208 hydraulic lines <input type="checkbox"/> <input type="checkbox"/> <input type="checkbox"/> <input type="checkbox"/> <input type="checkbox"/></p> <p>1209 load holding valve (piston side) <input type="checkbox"/> <input type="checkbox"/> <input type="checkbox"/> <input type="checkbox"/> <input type="checkbox"/></p> <p>1210 load holding valve (rod side) <input type="checkbox"/> <input type="checkbox"/> <input type="checkbox"/> <input type="checkbox"/> <input type="checkbox"/></p>	<p><b>1300 joint „E“</b></p> <p>1301 boom <input type="checkbox"/> <input type="checkbox"/> <input type="checkbox"/> <input type="checkbox"/> <input type="checkbox"/></p> <p>1302 link lever <input type="checkbox"/> <input type="checkbox"/> <input type="checkbox"/> <input type="checkbox"/> <input type="checkbox"/></p> <p>1303 forcing rod <input type="checkbox"/> <input type="checkbox"/> <input type="checkbox"/> <input type="checkbox"/> <input type="checkbox"/></p> <p>1304 pin <input type="checkbox"/> <input type="checkbox"/> <input type="checkbox"/> <input type="checkbox"/> <input type="checkbox"/></p> <p>1305 cylinder <input type="checkbox"/> <input type="checkbox"/> <input type="checkbox"/> <input type="checkbox"/> <input type="checkbox"/></p> <p>1306 boom speed <input type="checkbox"/> <input type="checkbox"/> <input type="checkbox"/> <input type="checkbox"/> <input type="checkbox"/></p> <p>1307 pressure settings <input type="checkbox"/> <input type="checkbox"/> <input type="checkbox"/> <input type="checkbox"/> <input type="checkbox"/></p> <p>1308 hydraulic lines <input type="checkbox"/> <input type="checkbox"/> <input type="checkbox"/> <input type="checkbox"/> <input type="checkbox"/></p> <p>1309 load holding valve (piston side) <input type="checkbox"/> <input type="checkbox"/> <input type="checkbox"/> <input type="checkbox"/> <input type="checkbox"/></p> <p>1310 load holding valve (rod side) <input type="checkbox"/> <input type="checkbox"/> <input type="checkbox"/> <input type="checkbox"/> <input type="checkbox"/></p> <p><b>1400 concrete delivery line</b></p> <p>1401 assembly of delivery line DN <input type="checkbox"/> <input type="checkbox"/> <input type="checkbox"/> <input type="checkbox"/> <input type="checkbox"/></p> <p>1402 end hose DN+length <input type="checkbox"/> <input type="checkbox"/> <input type="checkbox"/> <input type="checkbox"/> <input type="checkbox"/></p> <p>1403 delivery line DN <input type="checkbox"/> <input type="checkbox"/> <input type="checkbox"/> <input type="checkbox"/> <input type="checkbox"/></p> <p>1404 rotating joints of - delivery line <input type="checkbox"/> <input type="checkbox"/> <input type="checkbox"/> <input type="checkbox"/> <input type="checkbox"/></p> <p>1405 locking pin of the coupling <input type="checkbox"/> <input type="checkbox"/> <input type="checkbox"/> <input type="checkbox"/> <input type="checkbox"/></p> <p>Notes:</p> <hr/> <hr/> <hr/>
---	--

## Inspection report for concrete booms

Page 5-5

Inspection report Nr: \_\_\_\_\_ Boom type: \_\_\_\_\_ Machine-Nr: \_\_\_\_\_

**Error code:**

- |                  |                     |                   |                          |
|------------------|---------------------|-------------------|--------------------------|
| 00 no objections | 08 corrosion        | 16 porous         | 24 deformation           |
| 01 cracks        | 09 lacquer failures | 17 burned through | 25 bear movement         |
| 02 broken        | 10 fraying          | 18 not fixed      | 26 lubrication           |
| 03 leaky         | 11 scratched        | 19 clamp          | 27 readability           |
| 04 no function   | 12 bendet           | 20 sawing         | 28 missing components    |
| 05 low lifetime  | 13 noises           | 21 contaminated   | 29 hydraulical           |
| 06 worn out      | 14 vibration        | 22 bad contact    | 30 electrical            |
| 07 dirt          | 15 miscellaneous    | 23 temperature    | 31 reinspection required |

1406 end hose safety device

1407 reducer

1408 gate elbow, elbow 6"

**1500 hydraulic system and hydraulic valves**

1501 Pressure relief valve

1502 pressure settings

1503 hydraulic lines

1504 hand operating-  
(function)

1505 boom control valve

1506 hydraulic pump

**1600 electric equipment**

1601 remote control  
(functions)

1602 emergency stop  
(function)

1603 switch for outrigger  
function

1604 switch for boom  
function

1605 wiring harness

1606 central lubrication

**1700 sticker sets**

1701 safety hints

1702 description

1703 operating

1704 short operating  
instruction

1705 sticker „don't use  
the boom as crane“

1706 sticker „guideline  
operating with boom-  
and concrete pump“

1707 name plate

1708 sticker „danger  
high voltage“

**Competent inspector:**

Date: \_\_\_\_\_

Name: \_\_\_\_\_

Signature: \_\_\_\_\_  
(stamp)

**Customer:**

Signature: \_\_\_\_\_  
(stamp)

# Inspection report for concrete pump

Page 1-3

Inspection report Nr:	Machine-Nr:	Hours of operation:
		Concrete output m <sup>3</sup> :
Company:	Post code:	City:

NL      WV

Proof – Result of the tests

without defects	defects	reinspection required	shut down
<input type="checkbox"/>	<input type="checkbox"/>	<input type="checkbox"/>	<input type="checkbox"/>

Reinspection until date: .....

Error code:

- |                  |                     |                   |                          |
|------------------|---------------------|-------------------|--------------------------|
| 00 no objections | 08 corrosion        | 16 porous         | 24 deformation           |
| 01 cracks        | 09 lacquer failures | 17 burned through | 25 bear movement         |
| 02 broken        | 10 fraying          | 18 not fixed      | 26 lubrication           |
| 03 leaky         | 11 scratched        | 19 clomp          | 27 readability           |
| 04 no fuction    | 12 bendet           | 20 sawing         | 28 missing components    |
| 05 low livetime  | 13 noises           | 21 contaminated   | 29 hydraulical           |
| 06 worn out      | 14 vibration        | 22 bad contact    | 30 electrical            |
| 07 dirt          | 15 miscellaneous    | 23 temperature    | 31 reinspection required |

**2000 documents**

2001 operating manual	<input type="checkbox"/>	<input type="checkbox"/>	<input type="checkbox"/>	<input type="checkbox"/>	<input type="checkbox"/>
2002 spare parts list	<input type="checkbox"/>	<input type="checkbox"/>	<input type="checkbox"/>	<input type="checkbox"/>	<input type="checkbox"/>
<b>2100 drive assembly</b>					
2101 coupling and flange	<input type="checkbox"/>	<input type="checkbox"/>	<input type="checkbox"/>	<input type="checkbox"/>	<input type="checkbox"/>
2200 gear box	<input type="checkbox"/>	<input type="checkbox"/>	<input type="checkbox"/>	<input type="checkbox"/>	<input type="checkbox"/>
2300 hydraulic pump (main)	<input type="checkbox"/>	<input type="checkbox"/>	<input type="checkbox"/>	<input type="checkbox"/>	<input type="checkbox"/>
2400 oil-tank	<input type="checkbox"/>	<input type="checkbox"/>	<input type="checkbox"/>	<input type="checkbox"/>	<input type="checkbox"/>
2500 drive shaft	<input type="checkbox"/>	<input type="checkbox"/>	<input type="checkbox"/>	<input type="checkbox"/>	<input type="checkbox"/>

**2700 hydraulic control system**

2701 pressure relief valve	<input type="checkbox"/>	<input type="checkbox"/>	<input type="checkbox"/>	<input type="checkbox"/>	<input type="checkbox"/>
2702 pressure setting	<input type="checkbox"/>	<input type="checkbox"/>	<input type="checkbox"/>	<input type="checkbox"/>	<input type="checkbox"/>
2703 hydraulic line	<input type="checkbox"/>	<input type="checkbox"/>	<input type="checkbox"/>	<input type="checkbox"/>	<input type="checkbox"/>
2704 mechanical operation by hand	<input type="checkbox"/>	<input type="checkbox"/>	<input type="checkbox"/>	<input type="checkbox"/>	<input type="checkbox"/>
2800 oil-cooler	<input type="checkbox"/>	<input type="checkbox"/>	<input type="checkbox"/>	<input type="checkbox"/>	<input type="checkbox"/>
2900 accumulator	<input type="checkbox"/>	<input type="checkbox"/>	<input type="checkbox"/>	<input type="checkbox"/>	<input type="checkbox"/>
2901 proofs of the required tests according to accumulator regulation	<input type="checkbox"/>	<input type="checkbox"/>	<input type="checkbox"/>	<input type="checkbox"/>	<input type="checkbox"/>
2902 pressure gauge	<input type="checkbox"/>	<input type="checkbox"/>	<input type="checkbox"/>	<input type="checkbox"/>	<input type="checkbox"/>

Notes:



# Inspection report for concrete pump

Inspection report Nr: \_\_\_\_\_ Machine-Nr: \_\_\_\_\_

**Error code:**

00 no objections	08 corrosion	16 porous	24 deformation
01 cracks	09 lacquer failures	17 burned through	25 bear movement
02 broken	10 fraying	18 not fixed	26 lubrication
03 leaky	11 scratched	19 clomp	27 readability
04 no function	12 bendet	20 sawing	28 missing components
05 low lifetime	13 noises	21 contamitated	29 hydraulical
06 worn out	14 vibration	22 bad contact	30 electrical
07 dirt	15 miscellaneous	23 temperature	31 reinspection required

- 3000 central lubrication
- 3100 hydraulic motor
- 3200 hydraulic lines
- 3300 air compressor
- 3400 control panel
- 3500 concrete pump
- 3700 S-valve
- 3800 hopper
- 4100 sub frame
- 4200 water tank
- 4300 axle
- 4400 water pump
- 4500 vibrator

**4600 safety guards, equipment**

- 4601 stair
- 4602 safety for stair
- 4603 handrail
- 4604 hopper grid (fixing device)
- 4606 distance of grid rods
- 4607 distance from grid to agitator
- 4609 agitator have to stop if grid is open
- 4610 accumulator have to dump if grid is open
- 4612 cleaning flap hopper
- 4613 safety grid into water box

Notes:

# Inspection report for concrete pump

Inspection report Nr: \_\_\_\_\_ Machine-Nr: \_\_\_\_\_

**Error code:**

- |                  |                     |                   |                          |
|------------------|---------------------|-------------------|--------------------------|
| 00 no objections | 08 corrosion        | 16 porous         | 24 deformation           |
| 01 cracks        | 09 lacquer failures | 17 burned through | 25 bear movement         |
| 02 broken        | 10 fraying          | 18 not fixed      | 26 lubrication           |
| 03 leaky         | 11 scratched        | 19 clemp          | 27 readability           |
| 04 no function   | 12 bendet           | 20 sawing         | 28 missing components    |
| 05 low lifetime  | 13 noises           | 21 contamitated   | 29 hydraulical           |
| 06 worn out      | 14 vibration        | 22 bad contact    | 30 electrical            |
| 07 dirt          | 15 miscellaneous    | 23 temperature    | 31 reinspection required |

<p>4614 cover for rotating wave <input type="checkbox"/> <input type="checkbox"/> <input type="checkbox"/> <input type="checkbox"/> <input type="checkbox"/></p> <p>4616 cover for chains <input type="checkbox"/> <input type="checkbox"/> <input type="checkbox"/> <input type="checkbox"/> <input type="checkbox"/></p> <p>4617 cover for shift cylinder <input type="checkbox"/> <input type="checkbox"/> <input type="checkbox"/> <input type="checkbox"/> <input type="checkbox"/></p> <p>4618 cover for moving parts <input type="checkbox"/> <input type="checkbox"/> <input type="checkbox"/> <input type="checkbox"/> <input type="checkbox"/></p> <p>4619 cover for the exhaust pipe <input type="checkbox"/> <input type="checkbox"/> <input type="checkbox"/> <input type="checkbox"/> <input type="checkbox"/></p> <p><b>4700 electrical system</b></p> <p>4701 function of actuator component <input type="checkbox"/> <input type="checkbox"/> <input type="checkbox"/> <input type="checkbox"/> <input type="checkbox"/></p> <p>4702 emergency stop function <input type="checkbox"/> <input type="checkbox"/> <input type="checkbox"/> <input type="checkbox"/> <input type="checkbox"/></p> <p>4703 ground connections <input type="checkbox"/> <input type="checkbox"/> <input type="checkbox"/> <input type="checkbox"/> <input type="checkbox"/></p> <p>4704 cables and wiring harness <input type="checkbox"/> <input type="checkbox"/> <input type="checkbox"/> <input type="checkbox"/> <input type="checkbox"/></p> <p>4705 temperature switch <input type="checkbox"/> <input type="checkbox"/> <input type="checkbox"/> <input type="checkbox"/> <input type="checkbox"/></p> <p><b>4800 outrigger - system</b></p> <p>4801 transportation lock <input type="checkbox"/> <input type="checkbox"/> <input type="checkbox"/> <input type="checkbox"/> <input type="checkbox"/></p> <p>4802 locking device <input type="checkbox"/> <input type="checkbox"/> <input type="checkbox"/> <input type="checkbox"/> <input type="checkbox"/></p> <p>4803 backing plate <input type="checkbox"/> <input type="checkbox"/> <input type="checkbox"/> <input type="checkbox"/> <input type="checkbox"/></p>	<p>4804 jack cylinder connections <input type="checkbox"/> <input type="checkbox"/> <input type="checkbox"/> <input type="checkbox"/> <input type="checkbox"/></p> <p>4805 pressure adjustment of jack cylinder <input type="checkbox"/> <input type="checkbox"/> <input type="checkbox"/> <input type="checkbox"/> <input type="checkbox"/></p> <p><b>4900 miscellaneous</b></p> <p>4901 additional assembled part from operator <input type="checkbox"/> <input type="checkbox"/> <input type="checkbox"/> <input type="checkbox"/> <input type="checkbox"/></p> <p>4902 changes through operator <input type="checkbox"/> <input type="checkbox"/> <input type="checkbox"/> <input type="checkbox"/> <input type="checkbox"/></p>  <p><b>Competent inspector:</b></p> <p>Date: .....</p> <p>Name: .....</p> <p>Signature: ..... (stamp)</p> <p><b>Customer:</b></p> <p>Signature: ..... (stamp)</p> <p style="text-align: center;"><b>This test report is filed into the test book</b></p>
---	---

# Inspection report for concrete booms

Inspection report -Nr:	Machine-Nr	Hours of operation:	
Company:	Post code:	Concrete output m <sup>3</sup> :	
Boom Type:	Boom Nr.	NL	WV
City:			

**Proof – Result of the Tests**

without defects <input type="checkbox"/>	defects <input type="checkbox"/>	reinspection required <input type="checkbox"/>	shut down <input type="checkbox"/>
---	-------------------------------------	---	---------------------------------------

Reinspection until date:.....

**Error code:**

- |                  |                     |                   |                          |
|------------------|---------------------|-------------------|--------------------------|
| 00 no objections | 08 corrosion        | 16 porous         | 24 deformation           |
| 01 cracks        | 09 lacquer failures | 17 burned through | 25 bear movement         |
| 02 broken        | 10 fraying          | 18 not fixed      | 26 lubrication           |
| 03 leaky         | 11 scratched        | 19 clomp          | 27 readability           |
| 04 no function   | 12 bendet           | 20 sawing         | 28 missing components    |
| 05 low lifetime  | 13 noises           | 21 contaminated   | 29 hydraulical           |
| 06 worn out      | 14 vibration        | 22 bad contact    | 30 electrical            |
| 07 dirt          | 15 miscellaneous    | 23 temperature    | 31 reinspection required |

<p><b>100 documents</b></p> <p>101 instruction manual    <input type="checkbox"/> <input type="checkbox"/> <input type="checkbox"/> <input type="checkbox"/> <input type="checkbox"/></p> <p>102 spare parts list    <input type="checkbox"/> <input type="checkbox"/> <input type="checkbox"/> <input type="checkbox"/> <input type="checkbox"/></p> <p><b>200 sub frame</b></p> <p>201 frame connection cpl.    <input type="checkbox"/> <input type="checkbox"/> <input type="checkbox"/> <input type="checkbox"/> <input type="checkbox"/></p> <p><b>300 outrigger front R+L</b></p> <p>301 transportation safety device    <input type="checkbox"/> <input type="checkbox"/> <input type="checkbox"/> <input type="checkbox"/> <input type="checkbox"/></p> <p>302 outrigger    <input type="checkbox"/> <input type="checkbox"/> <input type="checkbox"/> <input type="checkbox"/> <input type="checkbox"/></p> <p>303 extension box    <input type="checkbox"/> <input type="checkbox"/> <input type="checkbox"/> <input type="checkbox"/> <input type="checkbox"/></p> <p>304 locking device    <input type="checkbox"/> <input type="checkbox"/> <input type="checkbox"/> <input type="checkbox"/> <input type="checkbox"/></p> <p>305 slewing bearing    <input type="checkbox"/> <input type="checkbox"/> <input type="checkbox"/> <input type="checkbox"/> <input type="checkbox"/></p> <p>306 turn locking device    <input type="checkbox"/> <input type="checkbox"/> <input type="checkbox"/> <input type="checkbox"/> <input type="checkbox"/></p> <p>307 support safeguard    <input type="checkbox"/> <input type="checkbox"/> <input type="checkbox"/> <input type="checkbox"/> <input type="checkbox"/></p> <p>308 support plate    <input type="checkbox"/> <input type="checkbox"/> <input type="checkbox"/> <input type="checkbox"/> <input type="checkbox"/></p> <p>309 fixing of jack cylinder    <input type="checkbox"/> <input type="checkbox"/> <input type="checkbox"/> <input type="checkbox"/> <input type="checkbox"/></p> <p>310 jack cylinder    <input type="checkbox"/> <input type="checkbox"/> <input type="checkbox"/> <input type="checkbox"/> <input type="checkbox"/></p>	<p>311 swing cylinder    <input type="checkbox"/> <input type="checkbox"/> <input type="checkbox"/> <input type="checkbox"/> <input type="checkbox"/></p> <p>312 telescopic-cylinder    <input type="checkbox"/> <input type="checkbox"/> <input type="checkbox"/> <input type="checkbox"/> <input type="checkbox"/></p> <p>313 pressure adjustment    <input type="checkbox"/> <input type="checkbox"/> <input type="checkbox"/> <input type="checkbox"/> <input type="checkbox"/></p> <p><b>400 outrigger rear L+R</b></p> <p>401 transportation safety device    <input type="checkbox"/> <input type="checkbox"/> <input type="checkbox"/> <input type="checkbox"/> <input type="checkbox"/></p> <p>402 outrigger    <input type="checkbox"/> <input type="checkbox"/> <input type="checkbox"/> <input type="checkbox"/> <input type="checkbox"/></p> <p>403 extension box    <input type="checkbox"/> <input type="checkbox"/> <input type="checkbox"/> <input type="checkbox"/> <input type="checkbox"/></p> <p>405 locking device    <input type="checkbox"/> <input type="checkbox"/> <input type="checkbox"/> <input type="checkbox"/> <input type="checkbox"/></p> <p>Notes:</p> <hr/> <hr/> <hr/> <hr/> <hr/>
--	--

# Inspection report for concrete booms

Inspection report Nr: \_\_\_\_\_ Boom type: \_\_\_\_\_ Machine-Nr: \_\_\_\_\_

Error code:			
00 no objections	08 corrosion	16 porous	24 deformation
01 cracks	09 lacquer failures	17 burned through	25 bear movement
02 broken	10 fraying	18 not fixed	26 lubrication
03 leaky	11 scratched	19 clemp	27 readability
04 no function	12 bendet	20 sawing	28 missing components
05 low lifetime	13 noises	21 contaminated	29 hydraulic
06 worn out	14 vibration	22 bad contact	30 electrical
07 dirt	15 miscellaneous	23 temperature	31 reinspection required

<table border="0" style="width: 100%;"> <tr> <td style="width: 30%;">406 slewing bearing</td> <td style="width: 20%;"><input type="checkbox"/></td><td><input type="checkbox"/></td><td><input type="checkbox"/></td><td><input type="checkbox"/></td><td><input type="checkbox"/></td> </tr> <tr> <td>407 turn locking device</td> <td><input type="checkbox"/></td><td><input type="checkbox"/></td><td><input type="checkbox"/></td><td><input type="checkbox"/></td><td><input type="checkbox"/></td> </tr> <tr> <td>408 support safeguard</td> <td><input type="checkbox"/></td><td><input type="checkbox"/></td><td><input type="checkbox"/></td><td><input type="checkbox"/></td><td><input type="checkbox"/></td> </tr> <tr> <td>409 support plate</td> <td><input type="checkbox"/></td><td><input type="checkbox"/></td><td><input type="checkbox"/></td><td><input type="checkbox"/></td><td><input type="checkbox"/></td> </tr> <tr> <td>410 fixing of jack cylinder</td> <td><input type="checkbox"/></td><td><input type="checkbox"/></td><td><input type="checkbox"/></td><td><input type="checkbox"/></td><td><input type="checkbox"/></td> </tr> <tr> <td>411 jack cylinder</td> <td><input type="checkbox"/></td><td><input type="checkbox"/></td><td><input type="checkbox"/></td><td><input type="checkbox"/></td><td><input type="checkbox"/></td> </tr> <tr> <td>412 swing cylinder</td> <td><input type="checkbox"/></td><td><input type="checkbox"/></td><td><input type="checkbox"/></td><td><input type="checkbox"/></td><td><input type="checkbox"/></td> </tr> <tr> <td>413 telescopic cylinder</td> <td><input type="checkbox"/></td><td><input type="checkbox"/></td><td><input type="checkbox"/></td><td><input type="checkbox"/></td><td><input type="checkbox"/></td> </tr> <tr> <td colspan="6"><b>500 pedestal</b></td> </tr> <tr> <td>501 pedestal mounting</td> <td><input type="checkbox"/></td><td><input type="checkbox"/></td><td><input type="checkbox"/></td><td><input type="checkbox"/></td><td><input type="checkbox"/></td> </tr> <tr> <td>502 sub frame</td> <td><input type="checkbox"/></td><td><input type="checkbox"/></td><td><input type="checkbox"/></td><td><input type="checkbox"/></td><td><input type="checkbox"/></td> </tr> <tr> <td>503 truck frame</td> <td><input type="checkbox"/></td><td><input type="checkbox"/></td><td><input type="checkbox"/></td><td><input type="checkbox"/></td><td><input type="checkbox"/></td> </tr> <tr> <td>504 pedestal (structure)</td> <td><input type="checkbox"/></td><td><input type="checkbox"/></td><td><input type="checkbox"/></td><td><input type="checkbox"/></td><td><input type="checkbox"/></td> </tr> <tr> <td>505 boom valve without leaking</td> <td><input type="checkbox"/></td><td><input type="checkbox"/></td><td><input type="checkbox"/></td><td><input type="checkbox"/></td><td><input type="checkbox"/></td> </tr> <tr> <td>506 boom rest</td> <td><input type="checkbox"/></td><td><input type="checkbox"/></td><td><input type="checkbox"/></td><td><input type="checkbox"/></td><td><input type="checkbox"/></td> </tr> <tr> <td>507 transportation safety device</td> <td><input type="checkbox"/></td><td><input type="checkbox"/></td><td><input type="checkbox"/></td><td><input type="checkbox"/></td><td><input type="checkbox"/></td> </tr> <tr> <td>508 hydraulic line</td> <td><input type="checkbox"/></td><td><input type="checkbox"/></td><td><input type="checkbox"/></td><td><input type="checkbox"/></td><td><input type="checkbox"/></td> </tr> <tr> <td colspan="6"><b>600 slewing head with ball pivot</b></td> </tr> <tr> <td>601 slewing head</td> <td><input type="checkbox"/></td><td><input type="checkbox"/></td><td><input type="checkbox"/></td><td><input type="checkbox"/></td><td><input type="checkbox"/></td> </tr> <tr> <td>602 ball pivot ring</td> <td><input type="checkbox"/></td><td><input type="checkbox"/></td><td><input type="checkbox"/></td><td><input type="checkbox"/></td><td><input type="checkbox"/></td> </tr> <tr> <td>603 mounting ball pivot ring</td> <td><input type="checkbox"/></td><td><input type="checkbox"/></td><td><input type="checkbox"/></td><td><input type="checkbox"/></td><td><input type="checkbox"/></td> </tr> <tr> <td>604 drive pinion</td> <td><input type="checkbox"/></td><td><input type="checkbox"/></td><td><input type="checkbox"/></td><td><input type="checkbox"/></td><td><input type="checkbox"/></td> </tr> </table>	406 slewing bearing	<input type="checkbox"/>	<input type="checkbox"/>	<input type="checkbox"/>	<input type="checkbox"/>	<input type="checkbox"/>	407 turn locking device	<input type="checkbox"/>	<input type="checkbox"/>	<input type="checkbox"/>	<input type="checkbox"/>	<input type="checkbox"/>	408 support safeguard	<input type="checkbox"/>	<input type="checkbox"/>	<input type="checkbox"/>	<input type="checkbox"/>	<input type="checkbox"/>	409 support plate	<input type="checkbox"/>	<input type="checkbox"/>	<input type="checkbox"/>	<input type="checkbox"/>	<input type="checkbox"/>	410 fixing of jack cylinder	<input type="checkbox"/>	<input type="checkbox"/>	<input type="checkbox"/>	<input type="checkbox"/>	<input type="checkbox"/>	411 jack cylinder	<input type="checkbox"/>	<input type="checkbox"/>	<input type="checkbox"/>	<input type="checkbox"/>	<input type="checkbox"/>	412 swing cylinder	<input type="checkbox"/>	<input type="checkbox"/>	<input type="checkbox"/>	<input type="checkbox"/>	<input type="checkbox"/>	413 telescopic cylinder	<input type="checkbox"/>	<input type="checkbox"/>	<input type="checkbox"/>	<input type="checkbox"/>	<input type="checkbox"/>	<b>500 pedestal</b>						501 pedestal mounting	<input type="checkbox"/>	<input type="checkbox"/>	<input type="checkbox"/>	<input type="checkbox"/>	<input type="checkbox"/>	502 sub frame	<input type="checkbox"/>	<input type="checkbox"/>	<input type="checkbox"/>	<input type="checkbox"/>	<input type="checkbox"/>	503 truck frame	<input type="checkbox"/>	<input type="checkbox"/>	<input type="checkbox"/>	<input type="checkbox"/>	<input type="checkbox"/>	504 pedestal (structure)	<input type="checkbox"/>	<input type="checkbox"/>	<input type="checkbox"/>	<input type="checkbox"/>	<input type="checkbox"/>	505 boom valve without leaking	<input type="checkbox"/>	<input type="checkbox"/>	<input type="checkbox"/>	<input type="checkbox"/>	<input type="checkbox"/>	506 boom rest	<input type="checkbox"/>	<input type="checkbox"/>	<input type="checkbox"/>	<input type="checkbox"/>	<input type="checkbox"/>	507 transportation safety device	<input type="checkbox"/>	<input type="checkbox"/>	<input type="checkbox"/>	<input type="checkbox"/>	<input type="checkbox"/>	508 hydraulic line	<input type="checkbox"/>	<input type="checkbox"/>	<input type="checkbox"/>	<input type="checkbox"/>	<input type="checkbox"/>	<b>600 slewing head with ball pivot</b>						601 slewing head	<input type="checkbox"/>	<input type="checkbox"/>	<input type="checkbox"/>	<input type="checkbox"/>	<input type="checkbox"/>	602 ball pivot ring	<input type="checkbox"/>	<input type="checkbox"/>	<input type="checkbox"/>	<input type="checkbox"/>	<input type="checkbox"/>	603 mounting ball pivot ring	<input type="checkbox"/>	<input type="checkbox"/>	<input type="checkbox"/>	<input type="checkbox"/>	<input type="checkbox"/>	604 drive pinion	<input type="checkbox"/>	<input type="checkbox"/>	<input type="checkbox"/>	<input type="checkbox"/>	<input type="checkbox"/>	<table border="0" style="width: 100%;"> <tr> <td style="width: 30%;">605 slewing drive mounting</td> <td style="width: 20%;"><input type="checkbox"/></td><td><input type="checkbox"/></td><td><input type="checkbox"/></td><td><input type="checkbox"/></td><td><input type="checkbox"/></td> </tr> <tr> <td>606 slewing stop device</td> <td><input type="checkbox"/></td><td><input type="checkbox"/></td><td><input type="checkbox"/></td><td><input type="checkbox"/></td><td><input type="checkbox"/></td> </tr> <tr> <td>607 slewing drive (tooth backlash)</td> <td><input type="checkbox"/></td><td><input type="checkbox"/></td><td><input type="checkbox"/></td><td><input type="checkbox"/></td><td><input type="checkbox"/></td> </tr> <tr> <td>608 slewing drive</td> <td><input type="checkbox"/></td><td><input type="checkbox"/></td><td><input type="checkbox"/></td><td><input type="checkbox"/></td><td><input type="checkbox"/></td> </tr> <tr> <td>609 brake function</td> <td><input type="checkbox"/></td><td><input type="checkbox"/></td><td><input type="checkbox"/></td><td><input type="checkbox"/></td><td><input type="checkbox"/></td> </tr> <tr> <td>610 speed</td> <td><input type="checkbox"/></td><td><input type="checkbox"/></td><td><input type="checkbox"/></td><td><input type="checkbox"/></td><td><input type="checkbox"/></td> </tr> <tr> <td>611 pressure setting</td> <td><input type="checkbox"/></td><td><input type="checkbox"/></td><td><input type="checkbox"/></td><td><input type="checkbox"/></td><td><input type="checkbox"/></td> </tr> <tr> <td>612 hydraulic lines</td> <td><input type="checkbox"/></td><td><input type="checkbox"/></td><td><input type="checkbox"/></td><td><input type="checkbox"/></td><td><input type="checkbox"/></td> </tr> <tr> <td colspan="6"><b>700 slewing head with slewing column</b></td> </tr> <tr> <td>701 slewing head</td> <td><input type="checkbox"/></td><td><input type="checkbox"/></td><td><input type="checkbox"/></td><td><input type="checkbox"/></td><td><input type="checkbox"/></td> </tr> <tr> <td>702 slewing column bearing</td> <td><input type="checkbox"/></td><td><input type="checkbox"/></td><td><input type="checkbox"/></td><td><input type="checkbox"/></td><td><input type="checkbox"/></td> </tr> <tr> <td>703 slewing drive (tooth backlash)</td> <td><input type="checkbox"/></td><td><input type="checkbox"/></td><td><input type="checkbox"/></td><td><input type="checkbox"/></td><td><input type="checkbox"/></td> </tr> <tr> <td>704 speed</td> <td><input type="checkbox"/></td><td><input type="checkbox"/></td><td><input type="checkbox"/></td><td><input type="checkbox"/></td><td><input type="checkbox"/></td> </tr> <tr> <td>705 pressure settings</td> <td><input type="checkbox"/></td><td><input type="checkbox"/></td><td><input type="checkbox"/></td><td><input type="checkbox"/></td><td><input type="checkbox"/></td> </tr> <tr> <td>706 hydraulic lines</td> <td><input type="checkbox"/></td><td><input type="checkbox"/></td><td><input type="checkbox"/></td><td><input type="checkbox"/></td><td><input type="checkbox"/></td> </tr> <tr> <td>707 swivel cylinder</td> <td><input type="checkbox"/></td><td><input type="checkbox"/></td><td><input type="checkbox"/></td><td><input type="checkbox"/></td><td><input type="checkbox"/></td> </tr> </table> <p>Notes:</p> <hr/> <hr/> <hr/> <hr/>	605 slewing drive mounting	<input type="checkbox"/>	<input type="checkbox"/>	<input type="checkbox"/>	<input type="checkbox"/>	<input type="checkbox"/>	606 slewing stop device	<input type="checkbox"/>	<input type="checkbox"/>	<input type="checkbox"/>	<input type="checkbox"/>	<input type="checkbox"/>	607 slewing drive (tooth backlash)	<input type="checkbox"/>	<input type="checkbox"/>	<input type="checkbox"/>	<input type="checkbox"/>	<input type="checkbox"/>	608 slewing drive	<input type="checkbox"/>	<input type="checkbox"/>	<input type="checkbox"/>	<input type="checkbox"/>	<input type="checkbox"/>	609 brake function	<input type="checkbox"/>	<input type="checkbox"/>	<input type="checkbox"/>	<input type="checkbox"/>	<input type="checkbox"/>	610 speed	<input type="checkbox"/>	<input type="checkbox"/>	<input type="checkbox"/>	<input type="checkbox"/>	<input type="checkbox"/>	611 pressure setting	<input type="checkbox"/>	<input type="checkbox"/>	<input type="checkbox"/>	<input type="checkbox"/>	<input type="checkbox"/>	612 hydraulic lines	<input type="checkbox"/>	<input type="checkbox"/>	<input type="checkbox"/>	<input type="checkbox"/>	<input type="checkbox"/>	<b>700 slewing head with slewing column</b>						701 slewing head	<input type="checkbox"/>	<input type="checkbox"/>	<input type="checkbox"/>	<input type="checkbox"/>	<input type="checkbox"/>	702 slewing column bearing	<input type="checkbox"/>	<input type="checkbox"/>	<input type="checkbox"/>	<input type="checkbox"/>	<input type="checkbox"/>	703 slewing drive (tooth backlash)	<input type="checkbox"/>	<input type="checkbox"/>	<input type="checkbox"/>	<input type="checkbox"/>	<input type="checkbox"/>	704 speed	<input type="checkbox"/>	<input type="checkbox"/>	<input type="checkbox"/>	<input type="checkbox"/>	<input type="checkbox"/>	705 pressure settings	<input type="checkbox"/>	<input type="checkbox"/>	<input type="checkbox"/>	<input type="checkbox"/>	<input type="checkbox"/>	706 hydraulic lines	<input type="checkbox"/>	<input type="checkbox"/>	<input type="checkbox"/>	<input type="checkbox"/>	<input type="checkbox"/>	707 swivel cylinder	<input type="checkbox"/>	<input type="checkbox"/>	<input type="checkbox"/>	<input type="checkbox"/>	<input type="checkbox"/>
406 slewing bearing	<input type="checkbox"/>	<input type="checkbox"/>	<input type="checkbox"/>	<input type="checkbox"/>	<input type="checkbox"/>																																																																																																																																																																																																																																
407 turn locking device	<input type="checkbox"/>	<input type="checkbox"/>	<input type="checkbox"/>	<input type="checkbox"/>	<input type="checkbox"/>																																																																																																																																																																																																																																
408 support safeguard	<input type="checkbox"/>	<input type="checkbox"/>	<input type="checkbox"/>	<input type="checkbox"/>	<input type="checkbox"/>																																																																																																																																																																																																																																
409 support plate	<input type="checkbox"/>	<input type="checkbox"/>	<input type="checkbox"/>	<input type="checkbox"/>	<input type="checkbox"/>																																																																																																																																																																																																																																
410 fixing of jack cylinder	<input type="checkbox"/>	<input type="checkbox"/>	<input type="checkbox"/>	<input type="checkbox"/>	<input type="checkbox"/>																																																																																																																																																																																																																																
411 jack cylinder	<input type="checkbox"/>	<input type="checkbox"/>	<input type="checkbox"/>	<input type="checkbox"/>	<input type="checkbox"/>																																																																																																																																																																																																																																
412 swing cylinder	<input type="checkbox"/>	<input type="checkbox"/>	<input type="checkbox"/>	<input type="checkbox"/>	<input type="checkbox"/>																																																																																																																																																																																																																																
413 telescopic cylinder	<input type="checkbox"/>	<input type="checkbox"/>	<input type="checkbox"/>	<input type="checkbox"/>	<input type="checkbox"/>																																																																																																																																																																																																																																
<b>500 pedestal</b>																																																																																																																																																																																																																																					
501 pedestal mounting	<input type="checkbox"/>	<input type="checkbox"/>	<input type="checkbox"/>	<input type="checkbox"/>	<input type="checkbox"/>																																																																																																																																																																																																																																
502 sub frame	<input type="checkbox"/>	<input type="checkbox"/>	<input type="checkbox"/>	<input type="checkbox"/>	<input type="checkbox"/>																																																																																																																																																																																																																																
503 truck frame	<input type="checkbox"/>	<input type="checkbox"/>	<input type="checkbox"/>	<input type="checkbox"/>	<input type="checkbox"/>																																																																																																																																																																																																																																
504 pedestal (structure)	<input type="checkbox"/>	<input type="checkbox"/>	<input type="checkbox"/>	<input type="checkbox"/>	<input type="checkbox"/>																																																																																																																																																																																																																																
505 boom valve without leaking	<input type="checkbox"/>	<input type="checkbox"/>	<input type="checkbox"/>	<input type="checkbox"/>	<input type="checkbox"/>																																																																																																																																																																																																																																
506 boom rest	<input type="checkbox"/>	<input type="checkbox"/>	<input type="checkbox"/>	<input type="checkbox"/>	<input type="checkbox"/>																																																																																																																																																																																																																																
507 transportation safety device	<input type="checkbox"/>	<input type="checkbox"/>	<input type="checkbox"/>	<input type="checkbox"/>	<input type="checkbox"/>																																																																																																																																																																																																																																
508 hydraulic line	<input type="checkbox"/>	<input type="checkbox"/>	<input type="checkbox"/>	<input type="checkbox"/>	<input type="checkbox"/>																																																																																																																																																																																																																																
<b>600 slewing head with ball pivot</b>																																																																																																																																																																																																																																					
601 slewing head	<input type="checkbox"/>	<input type="checkbox"/>	<input type="checkbox"/>	<input type="checkbox"/>	<input type="checkbox"/>																																																																																																																																																																																																																																
602 ball pivot ring	<input type="checkbox"/>	<input type="checkbox"/>	<input type="checkbox"/>	<input type="checkbox"/>	<input type="checkbox"/>																																																																																																																																																																																																																																
603 mounting ball pivot ring	<input type="checkbox"/>	<input type="checkbox"/>	<input type="checkbox"/>	<input type="checkbox"/>	<input type="checkbox"/>																																																																																																																																																																																																																																
604 drive pinion	<input type="checkbox"/>	<input type="checkbox"/>	<input type="checkbox"/>	<input type="checkbox"/>	<input type="checkbox"/>																																																																																																																																																																																																																																
605 slewing drive mounting	<input type="checkbox"/>	<input type="checkbox"/>	<input type="checkbox"/>	<input type="checkbox"/>	<input type="checkbox"/>																																																																																																																																																																																																																																
606 slewing stop device	<input type="checkbox"/>	<input type="checkbox"/>	<input type="checkbox"/>	<input type="checkbox"/>	<input type="checkbox"/>																																																																																																																																																																																																																																
607 slewing drive (tooth backlash)	<input type="checkbox"/>	<input type="checkbox"/>	<input type="checkbox"/>	<input type="checkbox"/>	<input type="checkbox"/>																																																																																																																																																																																																																																
608 slewing drive	<input type="checkbox"/>	<input type="checkbox"/>	<input type="checkbox"/>	<input type="checkbox"/>	<input type="checkbox"/>																																																																																																																																																																																																																																
609 brake function	<input type="checkbox"/>	<input type="checkbox"/>	<input type="checkbox"/>	<input type="checkbox"/>	<input type="checkbox"/>																																																																																																																																																																																																																																
610 speed	<input type="checkbox"/>	<input type="checkbox"/>	<input type="checkbox"/>	<input type="checkbox"/>	<input type="checkbox"/>																																																																																																																																																																																																																																
611 pressure setting	<input type="checkbox"/>	<input type="checkbox"/>	<input type="checkbox"/>	<input type="checkbox"/>	<input type="checkbox"/>																																																																																																																																																																																																																																
612 hydraulic lines	<input type="checkbox"/>	<input type="checkbox"/>	<input type="checkbox"/>	<input type="checkbox"/>	<input type="checkbox"/>																																																																																																																																																																																																																																
<b>700 slewing head with slewing column</b>																																																																																																																																																																																																																																					
701 slewing head	<input type="checkbox"/>	<input type="checkbox"/>	<input type="checkbox"/>	<input type="checkbox"/>	<input type="checkbox"/>																																																																																																																																																																																																																																
702 slewing column bearing	<input type="checkbox"/>	<input type="checkbox"/>	<input type="checkbox"/>	<input type="checkbox"/>	<input type="checkbox"/>																																																																																																																																																																																																																																
703 slewing drive (tooth backlash)	<input type="checkbox"/>	<input type="checkbox"/>	<input type="checkbox"/>	<input type="checkbox"/>	<input type="checkbox"/>																																																																																																																																																																																																																																
704 speed	<input type="checkbox"/>	<input type="checkbox"/>	<input type="checkbox"/>	<input type="checkbox"/>	<input type="checkbox"/>																																																																																																																																																																																																																																
705 pressure settings	<input type="checkbox"/>	<input type="checkbox"/>	<input type="checkbox"/>	<input type="checkbox"/>	<input type="checkbox"/>																																																																																																																																																																																																																																
706 hydraulic lines	<input type="checkbox"/>	<input type="checkbox"/>	<input type="checkbox"/>	<input type="checkbox"/>	<input type="checkbox"/>																																																																																																																																																																																																																																
707 swivel cylinder	<input type="checkbox"/>	<input type="checkbox"/>	<input type="checkbox"/>	<input type="checkbox"/>	<input type="checkbox"/>																																																																																																																																																																																																																																

# Inspection report for concrete booms

Inspection report Nr:	Boom type:	Machine-Nr:																																
<p>Error code:</p> <table style="width: 100%; border: none;"> <tr> <td style="width: 25%;">00 no objections</td> <td style="width: 25%;">08 corrosion</td> <td style="width: 25%;">16 porous</td> <td style="width: 25%;">24 deformation</td> </tr> <tr> <td>01 cracks</td> <td>09 lacquer failures</td> <td>17 burned through</td> <td>25 bear movement</td> </tr> <tr> <td>02 broken</td> <td>10 fraying</td> <td>18 not fixed</td> <td>26 lubrication</td> </tr> <tr> <td>03 leaky</td> <td>11 scratched</td> <td>19 clomp</td> <td>27 readability</td> </tr> <tr> <td>04 no function</td> <td>12 bendet</td> <td>20 sawing</td> <td>28 missing components</td> </tr> <tr> <td>05 low lifetime</td> <td>13 noises</td> <td>21 contaminated</td> <td>29 hydraulic</td> </tr> <tr> <td>06 worn out</td> <td>14 vibration</td> <td>22 bad contact</td> <td>30 electrical</td> </tr> <tr> <td>07 dirt</td> <td>15 miscellaneous</td> <td>23 temperature</td> <td>31 reinspection required</td> </tr> </table>			00 no objections	08 corrosion	16 porous	24 deformation	01 cracks	09 lacquer failures	17 burned through	25 bear movement	02 broken	10 fraying	18 not fixed	26 lubrication	03 leaky	11 scratched	19 clomp	27 readability	04 no function	12 bendet	20 sawing	28 missing components	05 low lifetime	13 noises	21 contaminated	29 hydraulic	06 worn out	14 vibration	22 bad contact	30 electrical	07 dirt	15 miscellaneous	23 temperature	31 reinspection required
00 no objections	08 corrosion	16 porous	24 deformation																															
01 cracks	09 lacquer failures	17 burned through	25 bear movement																															
02 broken	10 fraying	18 not fixed	26 lubrication																															
03 leaky	11 scratched	19 clomp	27 readability																															
04 no function	12 bendet	20 sawing	28 missing components																															
05 low lifetime	13 noises	21 contaminated	29 hydraulic																															
06 worn out	14 vibration	22 bad contact	30 electrical																															
07 dirt	15 miscellaneous	23 temperature	31 reinspection required																															

<p><b>800 boom</b></p> <p>801 „Arm 1“ <input type="checkbox"/> <input type="checkbox"/> <input type="checkbox"/> <input type="checkbox"/> <input type="checkbox"/></p> <p>802 bracket conveying line <input type="checkbox"/> <input type="checkbox"/> <input type="checkbox"/> <input type="checkbox"/> <input type="checkbox"/></p> <p>803 Drop hook <input type="checkbox"/> <input type="checkbox"/> <input type="checkbox"/> <input type="checkbox"/> <input type="checkbox"/></p> <p>804 „Arm 2“ <input type="checkbox"/> <input type="checkbox"/> <input type="checkbox"/> <input type="checkbox"/> <input type="checkbox"/></p> <p>805 bracket conveying line <input type="checkbox"/> <input type="checkbox"/> <input type="checkbox"/> <input type="checkbox"/> <input type="checkbox"/></p> <p>806 Drop hook <input type="checkbox"/> <input type="checkbox"/> <input type="checkbox"/> <input type="checkbox"/> <input type="checkbox"/></p> <p>807 „Arm 3“ <input type="checkbox"/> <input type="checkbox"/> <input type="checkbox"/> <input type="checkbox"/> <input type="checkbox"/></p> <p>808 bracket conveying line <input type="checkbox"/> <input type="checkbox"/> <input type="checkbox"/> <input type="checkbox"/> <input type="checkbox"/></p> <p>809 guidance and interlock of the arm <input type="checkbox"/> <input type="checkbox"/> <input type="checkbox"/> <input type="checkbox"/> <input type="checkbox"/></p> <p>810 „Arm 4“ <input type="checkbox"/> <input type="checkbox"/> <input type="checkbox"/> <input type="checkbox"/> <input type="checkbox"/></p> <p>811 bracket conveying line <input type="checkbox"/> <input type="checkbox"/> <input type="checkbox"/> <input type="checkbox"/> <input type="checkbox"/></p> <p>812 guidance and interlock of the arm <input type="checkbox"/> <input type="checkbox"/> <input type="checkbox"/> <input type="checkbox"/> <input type="checkbox"/></p> <p>813 „Arm 5“ <input type="checkbox"/> <input type="checkbox"/> <input type="checkbox"/> <input type="checkbox"/> <input type="checkbox"/></p> <p>814 bracket conveying line <input type="checkbox"/> <input type="checkbox"/> <input type="checkbox"/> <input type="checkbox"/> <input type="checkbox"/></p> <p>815 guidance and interlock of the arm <input type="checkbox"/> <input type="checkbox"/> <input type="checkbox"/> <input type="checkbox"/> <input type="checkbox"/></p> <p><b>900 joint „A“</b></p> <p>901 boom <input type="checkbox"/> <input type="checkbox"/> <input type="checkbox"/> <input type="checkbox"/> <input type="checkbox"/></p> <p>902 link lever <input type="checkbox"/> <input type="checkbox"/> <input type="checkbox"/> <input type="checkbox"/> <input type="checkbox"/></p> <p>903 forcing rod <input type="checkbox"/> <input type="checkbox"/> <input type="checkbox"/> <input type="checkbox"/> <input type="checkbox"/></p> <p>904 pin <input type="checkbox"/> <input type="checkbox"/> <input type="checkbox"/> <input type="checkbox"/> <input type="checkbox"/></p> <p>905 cylinder <input type="checkbox"/> <input type="checkbox"/> <input type="checkbox"/> <input type="checkbox"/> <input type="checkbox"/></p>	<p>906 boom speed <input type="checkbox"/> <input type="checkbox"/> <input type="checkbox"/> <input type="checkbox"/> <input type="checkbox"/></p> <p>907 pressure settings <input type="checkbox"/> <input type="checkbox"/> <input type="checkbox"/> <input type="checkbox"/> <input type="checkbox"/></p> <p>908 hydraulic lines <input type="checkbox"/> <input type="checkbox"/> <input type="checkbox"/> <input type="checkbox"/> <input type="checkbox"/></p> <p>909 load holding valve (piston side) <input type="checkbox"/> <input type="checkbox"/> <input type="checkbox"/> <input type="checkbox"/> <input type="checkbox"/></p> <p>910 load holding valve (rod side) <input type="checkbox"/> <input type="checkbox"/> <input type="checkbox"/> <input type="checkbox"/> <input type="checkbox"/></p> <p><b>1000 joint „B“</b></p> <p>1001 boom <input type="checkbox"/> <input type="checkbox"/> <input type="checkbox"/> <input type="checkbox"/> <input type="checkbox"/></p> <p>1002 link lever <input type="checkbox"/> <input type="checkbox"/> <input type="checkbox"/> <input type="checkbox"/> <input type="checkbox"/></p> <p>1003 forcing rod <input type="checkbox"/> <input type="checkbox"/> <input type="checkbox"/> <input type="checkbox"/> <input type="checkbox"/></p> <p>1004 pin <input type="checkbox"/> <input type="checkbox"/> <input type="checkbox"/> <input type="checkbox"/> <input type="checkbox"/></p> <p>1005 cylinder <input type="checkbox"/> <input type="checkbox"/> <input type="checkbox"/> <input type="checkbox"/> <input type="checkbox"/></p> <p>1006 boom speed <input type="checkbox"/> <input type="checkbox"/> <input type="checkbox"/> <input type="checkbox"/> <input type="checkbox"/></p> <p>1007 pressure settings <input type="checkbox"/> <input type="checkbox"/> <input type="checkbox"/> <input type="checkbox"/> <input type="checkbox"/></p> <p>1008 hydraulic lines <input type="checkbox"/> <input type="checkbox"/> <input type="checkbox"/> <input type="checkbox"/> <input type="checkbox"/></p> <p>1009 load holding valve (piston side) <input type="checkbox"/> <input type="checkbox"/> <input type="checkbox"/> <input type="checkbox"/> <input type="checkbox"/></p> <p>1010 load holding valve (rod side) <input type="checkbox"/> <input type="checkbox"/> <input type="checkbox"/> <input type="checkbox"/> <input type="checkbox"/></p> <p>Notes:</p> <hr/> <hr/> <hr/> <hr/>
--	---

# Inspection report for concrete booms

Inspection report Nr: \_\_\_\_\_ Boom type: \_\_\_\_\_ Machine-Nr: \_\_\_\_\_

Error code:			
00 no objections	08 corrosion	16 porous	24 deformation
01 cracks	09 lacquer failures	17 burned through	25 bear movement
02 broken	10 fraying	18 not fixed	26 lubrication
03 leaky	11 scratched	19 clomp	27 readability
04 no function	12 bendet	20 sawing	28 missing components
05 low lifetime	13 noises	21 contaminated	29 hydraulic
06 worn out	14 vibration	22 bad contact	30 electrical
07 dirt	15 miscellaneous	23 temperature	31 reinspection required

<p><b>1100 joint "C"</b></p> <p>1101 boom <input type="checkbox"/> <input type="checkbox"/> <input type="checkbox"/> <input type="checkbox"/> <input type="checkbox"/></p> <p>1102 link lever <input type="checkbox"/> <input type="checkbox"/> <input type="checkbox"/> <input type="checkbox"/> <input type="checkbox"/></p> <p>1103 forcing rod <input type="checkbox"/> <input type="checkbox"/> <input type="checkbox"/> <input type="checkbox"/> <input type="checkbox"/></p> <p>1104 pin <input type="checkbox"/> <input type="checkbox"/> <input type="checkbox"/> <input type="checkbox"/> <input type="checkbox"/></p> <p>1105 cylinder <input type="checkbox"/> <input type="checkbox"/> <input type="checkbox"/> <input type="checkbox"/> <input type="checkbox"/></p> <p>1106 boom speed <input type="checkbox"/> <input type="checkbox"/> <input type="checkbox"/> <input type="checkbox"/> <input type="checkbox"/></p> <p>1107 pressure settings <input type="checkbox"/> <input type="checkbox"/> <input type="checkbox"/> <input type="checkbox"/> <input type="checkbox"/></p> <p>1108 hydraulic lines <input type="checkbox"/> <input type="checkbox"/> <input type="checkbox"/> <input type="checkbox"/> <input type="checkbox"/></p> <p>1109 load holding valve (piston side) <input type="checkbox"/> <input type="checkbox"/> <input type="checkbox"/> <input type="checkbox"/> <input type="checkbox"/></p> <p>1110 load holding valve (rod side) <input type="checkbox"/> <input type="checkbox"/> <input type="checkbox"/> <input type="checkbox"/> <input type="checkbox"/></p> <p><b>1200 joint "D"</b></p> <p>1201 boom <input type="checkbox"/> <input type="checkbox"/> <input type="checkbox"/> <input type="checkbox"/> <input type="checkbox"/></p> <p>1202 link lever <input type="checkbox"/> <input type="checkbox"/> <input type="checkbox"/> <input type="checkbox"/> <input type="checkbox"/></p> <p>1203 forcing rod <input type="checkbox"/> <input type="checkbox"/> <input type="checkbox"/> <input type="checkbox"/> <input type="checkbox"/></p> <p>1204 pin <input type="checkbox"/> <input type="checkbox"/> <input type="checkbox"/> <input type="checkbox"/> <input type="checkbox"/></p> <p>1205 cylinder <input type="checkbox"/> <input type="checkbox"/> <input type="checkbox"/> <input type="checkbox"/> <input type="checkbox"/></p> <p>1206 boom speed <input type="checkbox"/> <input type="checkbox"/> <input type="checkbox"/> <input type="checkbox"/> <input type="checkbox"/></p> <p>1207 pressure settings <input type="checkbox"/> <input type="checkbox"/> <input type="checkbox"/> <input type="checkbox"/> <input type="checkbox"/></p> <p>1208 hydraulic lines <input type="checkbox"/> <input type="checkbox"/> <input type="checkbox"/> <input type="checkbox"/> <input type="checkbox"/></p> <p>1209 load holding valve (piston side) <input type="checkbox"/> <input type="checkbox"/> <input type="checkbox"/> <input type="checkbox"/> <input type="checkbox"/></p> <p>1210 load holding valve (rod side) <input type="checkbox"/> <input type="checkbox"/> <input type="checkbox"/> <input type="checkbox"/> <input type="checkbox"/></p>	<p><b>1300 joint „E“</b></p> <p>1301 boom <input type="checkbox"/> <input type="checkbox"/> <input type="checkbox"/> <input type="checkbox"/> <input type="checkbox"/></p> <p>1302 link lever <input type="checkbox"/> <input type="checkbox"/> <input type="checkbox"/> <input type="checkbox"/> <input type="checkbox"/></p> <p>1303 forcing rod <input type="checkbox"/> <input type="checkbox"/> <input type="checkbox"/> <input type="checkbox"/> <input type="checkbox"/></p> <p>1304 pin <input type="checkbox"/> <input type="checkbox"/> <input type="checkbox"/> <input type="checkbox"/> <input type="checkbox"/></p> <p>1305 cylinder <input type="checkbox"/> <input type="checkbox"/> <input type="checkbox"/> <input type="checkbox"/> <input type="checkbox"/></p> <p>1306 boom speed <input type="checkbox"/> <input type="checkbox"/> <input type="checkbox"/> <input type="checkbox"/> <input type="checkbox"/></p> <p>1307 pressure settings <input type="checkbox"/> <input type="checkbox"/> <input type="checkbox"/> <input type="checkbox"/> <input type="checkbox"/></p> <p>1308 hydraulic lines <input type="checkbox"/> <input type="checkbox"/> <input type="checkbox"/> <input type="checkbox"/> <input type="checkbox"/></p> <p>1309 load holding valve (piston side) <input type="checkbox"/> <input type="checkbox"/> <input type="checkbox"/> <input type="checkbox"/> <input type="checkbox"/></p> <p>1310 load holding valve (rod side) <input type="checkbox"/> <input type="checkbox"/> <input type="checkbox"/> <input type="checkbox"/> <input type="checkbox"/></p> <p><b>1400 concrete delivery line</b></p> <p>1401 assembly of delivery line DN <input type="checkbox"/> <input type="checkbox"/> <input type="checkbox"/> <input type="checkbox"/> <input type="checkbox"/></p> <p>1402 end hose DN+lenght <input type="checkbox"/> <input type="checkbox"/> <input type="checkbox"/> <input type="checkbox"/> <input type="checkbox"/></p> <p>1403 delivery line DN <input type="checkbox"/> <input type="checkbox"/> <input type="checkbox"/> <input type="checkbox"/> <input type="checkbox"/></p> <p>1404 rotating joints of - delivery line <input type="checkbox"/> <input type="checkbox"/> <input type="checkbox"/> <input type="checkbox"/> <input type="checkbox"/></p> <p>1405 locking pin of the coupling <input type="checkbox"/> <input type="checkbox"/> <input type="checkbox"/> <input type="checkbox"/> <input type="checkbox"/></p> <p>Notes:</p> <hr/> <hr/> <hr/>
---	--

## Inspection report for concrete booms

Inspection report Nr: \_\_\_\_\_ Boom type: \_\_\_\_\_ Machine-Nr: \_\_\_\_\_

**Error code:**

- |                  |                     |                   |                          |
|------------------|---------------------|-------------------|--------------------------|
| 00 no objections | 08 corrosion        | 16 porous         | 24 deformation           |
| 01 cracks        | 09 lacquer failures | 17 burned through | 25 bear movement         |
| 02 broken        | 10 fraying          | 18 not fixed      | 26 lubrication           |
| 03 leaky         | 11 scratched        | 19 clemp          | 27 readability           |
| 04 no function   | 12 bendet           | 20 sawing         | 28 missing components    |
| 05 low lifetime  | 13 noises           | 21 contaminated   | 29 hydraulical           |
| 06 worn out      | 14 vibration        | 22 bad contact    | 30 electrical            |
| 07 dirt          | 15 miscellaneous    | 23 temperature    | 31 reinspection required |

<p>1406 end hose safety device <input type="checkbox"/> <input type="checkbox"/> <input type="checkbox"/> <input type="checkbox"/> <input type="checkbox"/></p> <p>1407 reducer <input type="checkbox"/> <input type="checkbox"/> <input type="checkbox"/> <input type="checkbox"/> <input type="checkbox"/></p> <p>1408 gate elbow, elbow 6" <input type="checkbox"/> <input type="checkbox"/> <input type="checkbox"/> <input type="checkbox"/> <input type="checkbox"/></p> <p><b>1500 hydraulic system and hydraulic valves</b></p> <p>1501 Pressure relief valve <input type="checkbox"/> <input type="checkbox"/> <input type="checkbox"/> <input type="checkbox"/> <input type="checkbox"/></p> <p>1502 pressure settings <input type="checkbox"/> <input type="checkbox"/> <input type="checkbox"/> <input type="checkbox"/> <input type="checkbox"/></p> <p>1503 hydraulic lines <input type="checkbox"/> <input type="checkbox"/> <input type="checkbox"/> <input type="checkbox"/> <input type="checkbox"/></p> <p>1504 hand operating- (function) <input type="checkbox"/> <input type="checkbox"/> <input type="checkbox"/> <input type="checkbox"/> <input type="checkbox"/></p> <p>1505 boom control valve <input type="checkbox"/> <input type="checkbox"/> <input type="checkbox"/> <input type="checkbox"/> <input type="checkbox"/></p> <p>1506 hydraulic pump <input type="checkbox"/> <input type="checkbox"/> <input type="checkbox"/> <input type="checkbox"/> <input type="checkbox"/></p> <p><b>1600 electric equipment</b></p> <p>1601 remote control (functions) <input type="checkbox"/> <input type="checkbox"/> <input type="checkbox"/> <input type="checkbox"/> <input type="checkbox"/></p> <p>1602 emergency stop (function) <input type="checkbox"/> <input type="checkbox"/> <input type="checkbox"/> <input type="checkbox"/> <input type="checkbox"/></p> <p>1603 switch for outrigger function <input type="checkbox"/> <input type="checkbox"/> <input type="checkbox"/> <input type="checkbox"/> <input type="checkbox"/></p> <p>1604 switch for boom function <input type="checkbox"/> <input type="checkbox"/> <input type="checkbox"/> <input type="checkbox"/> <input type="checkbox"/></p> <p>1605 wiring harness <input type="checkbox"/> <input type="checkbox"/> <input type="checkbox"/> <input type="checkbox"/> <input type="checkbox"/></p> <p>1606 central lubrication <input type="checkbox"/> <input type="checkbox"/> <input type="checkbox"/> <input type="checkbox"/> <input type="checkbox"/></p>	<p><b>1700 sticker sets</b></p> <p>1701 safety hints <input type="checkbox"/> <input type="checkbox"/> <input type="checkbox"/> <input type="checkbox"/> <input type="checkbox"/></p> <p>1702 description <input type="checkbox"/> <input type="checkbox"/> <input type="checkbox"/> <input type="checkbox"/> <input type="checkbox"/></p> <p>1703 operating <input type="checkbox"/> <input type="checkbox"/> <input type="checkbox"/> <input type="checkbox"/> <input type="checkbox"/></p> <p>1704 short operating instruction <input type="checkbox"/> <input type="checkbox"/> <input type="checkbox"/> <input type="checkbox"/> <input type="checkbox"/></p> <p>1705 sticker „ don't use the boom as crane“ <input type="checkbox"/> <input type="checkbox"/> <input type="checkbox"/> <input type="checkbox"/> <input type="checkbox"/></p> <p>1706 sticker „guideline operating with boom- and concrete pump“ <input type="checkbox"/> <input type="checkbox"/> <input type="checkbox"/> <input type="checkbox"/> <input type="checkbox"/></p> <p>1707 name plate <input type="checkbox"/> <input type="checkbox"/> <input type="checkbox"/> <input type="checkbox"/> <input type="checkbox"/></p> <p>1708 sticker „danger high voltage“ <input type="checkbox"/> <input type="checkbox"/> <input type="checkbox"/> <input type="checkbox"/> <input type="checkbox"/></p> <hr/> <p><b>Competent inspector:</b></p> <p>Date: _____</p> <p>Name: _____</p> <p>Signature: _____ (stamp)</p> <p><b>Customer:</b></p> <p>Signature: _____ (stamp)</p>
---	--

# Inspection report for concrete pump

Inspection report Nr:	Machine-Nr:	Hours of operation:
		Concrete output m <sup>3</sup> :
Company:	Post code:	City:

NL	WV
----	----

**Proof – Result of the tests**

without defects	defects	reinspection required	shut down
<input type="checkbox"/>	<input type="checkbox"/>	<input type="checkbox"/>	<input type="checkbox"/>

Reinspection until date: .....

- Error code:**
- |                  |                     |                   |                          |
|------------------|---------------------|-------------------|--------------------------|
| 00 no objections | 08 corrosion        | 16 porous         | 24 deformation           |
| 01 cracks        | 09 lacquer failures | 17 burned through | 25 bear movement         |
| 02 broken        | 10 fraying          | 18 not fixed      | 26 lubrication           |
| 03 leaky         | 11 scratched        | 19 clomp          | 27 readability           |
| 04 no fuction    | 12 bendet           | 20 sawing         | 28 missing components    |
| 05 low livetime  | 13 noises           | 21 contaminated   | 29 hydraulical           |
| 06 worn out      | 14 vibration        | 22 bad contact    | 30 electrical            |
| 07 dirt          | 15 miscellaneous    | 23 temperature    | 31 reinspection required |

**2000 documents**

2001 operating manual   

2002 spare parts list   

**2100 drive assembly**

2101 coupling and flange   

2200 gear box   

2300 hydraulic pump (main)   

2400 oil-tank   

2500 drive shaft   

**2700 hydraulic control system**

2701 pressure relief valve   

2702 pressure setting   

2703 hydraulic line   

2704 mechanical operation by hand   

2800 oil-cooler   

2900 accumulator   

2901 proofs of the required tests according to accumulator regulation   

2902 pressure gauge   

Notes:

---



---



---



# Inspection report for concrete pump

Inspection report Nr: \_\_\_\_\_ Machine-Nr: \_\_\_\_\_

**Error code:**

- |                  |                     |                   |                          |
|------------------|---------------------|-------------------|--------------------------|
| 00 no objections | 08 corrosion        | 16 porous         | 24 deformation           |
| 01 cracks        | 09 lacquer failures | 17 burned through | 25 bear movement         |
| 02 broken        | 10 fraying          | 18 not fixed      | 26 lubrication           |
| 03 leaky         | 11 scratched        | 19 clemp          | 27 readability           |
| 04 no function   | 12 bendet           | 20 sawing         | 28 missing components    |
| 05 low lifetime  | 13 noises           | 21 contamitated   | 29 hydraulical           |
| 06 worn out      | 14 vibration        | 22 bad contact    | 30 electrical            |
| 07 dirt          | 15 miscellaneous    | 23 temperature    | 31 reinspection required |

<p><b>3000 central lubrication</b>    <input type="checkbox"/> <input type="checkbox"/> <input type="checkbox"/> <input type="checkbox"/> <input type="checkbox"/></p> <p><b>3100 hydraulic motor</b>    <input type="checkbox"/> <input type="checkbox"/> <input type="checkbox"/> <input type="checkbox"/> <input type="checkbox"/></p> <p><b>3200 hydraulic lines</b>    <input type="checkbox"/> <input type="checkbox"/> <input type="checkbox"/> <input type="checkbox"/> <input type="checkbox"/></p> <p><b>3300 air compressor</b>    <input type="checkbox"/> <input type="checkbox"/> <input type="checkbox"/> <input type="checkbox"/> <input type="checkbox"/></p> <p><b>3400 control panel</b>    <input type="checkbox"/> <input type="checkbox"/> <input type="checkbox"/> <input type="checkbox"/> <input type="checkbox"/></p> <p><b>3500 concrete pump</b>    <input type="checkbox"/> <input type="checkbox"/> <input type="checkbox"/> <input type="checkbox"/> <input type="checkbox"/></p> <p><b>3700 S-valve</b>    <input type="checkbox"/> <input type="checkbox"/> <input type="checkbox"/> <input type="checkbox"/> <input type="checkbox"/></p> <p><b>3800 hopper</b>    <input type="checkbox"/> <input type="checkbox"/> <input type="checkbox"/> <input type="checkbox"/> <input type="checkbox"/></p> <p><b>4100 sub frame</b>    <input type="checkbox"/> <input type="checkbox"/> <input type="checkbox"/> <input type="checkbox"/> <input type="checkbox"/></p> <p><b>4200 water tank</b>    <input type="checkbox"/> <input type="checkbox"/> <input type="checkbox"/> <input type="checkbox"/> <input type="checkbox"/></p> <p><b>4300 axle</b>    <input type="checkbox"/> <input type="checkbox"/> <input type="checkbox"/> <input type="checkbox"/> <input type="checkbox"/></p> <p><b>4400 water pump</b>    <input type="checkbox"/> <input type="checkbox"/> <input type="checkbox"/> <input type="checkbox"/> <input type="checkbox"/></p> <p><b>4500 vibrator</b>    <input type="checkbox"/> <input type="checkbox"/> <input type="checkbox"/> <input type="checkbox"/> <input type="checkbox"/></p>	<p><b>4600 safety guards, equipment</b></p> <p>4601 stair    <input type="checkbox"/> <input type="checkbox"/> <input type="checkbox"/> <input type="checkbox"/> <input type="checkbox"/></p> <p>4602 safety for stair    <input type="checkbox"/> <input type="checkbox"/> <input type="checkbox"/> <input type="checkbox"/> <input type="checkbox"/></p> <p>4603 handrail    <input type="checkbox"/> <input type="checkbox"/> <input type="checkbox"/> <input type="checkbox"/> <input type="checkbox"/></p> <p>4604 hopper grid (fixing device)    <input type="checkbox"/> <input type="checkbox"/> <input type="checkbox"/> <input type="checkbox"/> <input type="checkbox"/></p> <p>4606 distance of grid rods    <input type="checkbox"/> <input type="checkbox"/> <input type="checkbox"/> <input type="checkbox"/> <input type="checkbox"/></p> <p>4607 distance from grid to agitator    <input type="checkbox"/> <input type="checkbox"/> <input type="checkbox"/> <input type="checkbox"/> <input type="checkbox"/></p> <p>4609 agitator have to stop if grid is open    <input type="checkbox"/> <input type="checkbox"/> <input type="checkbox"/> <input type="checkbox"/> <input type="checkbox"/></p> <p>4610 accumulator have to dump if grid is open    <input type="checkbox"/> <input type="checkbox"/> <input type="checkbox"/> <input type="checkbox"/> <input type="checkbox"/></p> <p>4612 cleaning flap hopper    <input type="checkbox"/> <input type="checkbox"/> <input type="checkbox"/> <input type="checkbox"/> <input type="checkbox"/></p> <p>4613 safety grid into water box    <input type="checkbox"/> <input type="checkbox"/> <input type="checkbox"/> <input type="checkbox"/> <input type="checkbox"/></p>
--	---

Notes:

---



---



---



---

# Inspection report for concrete pump

Inspection report Nr: \_\_\_\_\_ Machine-Nr: \_\_\_\_\_

**Error code:**

- |                  |                     |                   |                          |
|------------------|---------------------|-------------------|--------------------------|
| 00 no objections | 08 corrosion        | 16 porous         | 24 deformation           |
| 01 cracks        | 09 lacquer failures | 17 burned through | 25 bear movement         |
| 02 broken        | 10 fraying          | 18 not fixed      | 26 lubrication           |
| 03 leaky         | 11 scratched        | 19 clemp          | 27 readability           |
| 04 no function   | 12 bendet           | 20 sawing         | 28 missing components    |
| 05 low lifetime  | 13 noises           | 21 contamitated   | 29 hydraulical           |
| 06 worn out      | 14 vibration        | 22 bad contact    | 30 electrical            |
| 07 dirt          | 15 miscellaneous    | 23 temperature    | 31 reinspection required |

4614 cover for rotating wave

4616 cover for chains

4617 cover for shift cylinder

4618 cover for moving parts

4619 cover for the exhaust pipe

**4700 electrical system**

4701 function of actuator component

4702 emergency stop function

4703 ground connections

4704 cables and wiring harness

4705 temperature switch

**4800 outrigger - system**

4801 transportation lock

4802 locking device

4803 backing plate

4804 jack cylinder connections

4805 pressure adjustment of jack cylinder

**4900 miscellaneous**

4901 additional assembled part from operator

4902 changes through operator

**Competent inspector:**

Date: .....

Name: .....

Signature: .....  
(stamp)

**Customer:**

Signature: .....  
(stamp)

**This test report is filed into the test book**

# Inspection report for concrete booms

Inspection report -Nr:	Machine-Nr:	Hours of operation:	
		Concrete output m³:	
Company:	Post code:	City:	
Boom Type:	Boom Nr.:	NL	WV

**Proof – Result of the Tests**

without defects	defects	reinspection required	shut down
<input type="checkbox"/>	<input type="checkbox"/>	<input type="checkbox"/>	<input type="checkbox"/>

Reinspection until date: .....

**Error code:**

00 no objections	08 corrosion	16 porous	24 deformation
01 cracks	09 lacquer failures	17 burned through	25 bear movement
02 broken	10 fraying	18 not fixed	26 lubrication
03 leaky	11 scratched	19 clomp	27 readability
04 no function	12 bendet	20 sawing	28 missing components
05 low lifetime	13 noises	21 contaminated	29 hydraulic
06 worn out	14 vibration	22 bad contact	30 electrical
07 dirt	15 miscellaneous	23 temperature	31 reinspection required

<p><b>100 documents</b></p> <p>101 instruction manual    <input type="checkbox"/> <input type="checkbox"/> <input type="checkbox"/> <input type="checkbox"/> <input type="checkbox"/></p> <p>102 spare parts list    <input type="checkbox"/> <input type="checkbox"/> <input type="checkbox"/> <input type="checkbox"/> <input type="checkbox"/></p> <p><b>200 sub frame</b></p> <p>201 frame connection cpl.    <input type="checkbox"/> <input type="checkbox"/> <input type="checkbox"/> <input type="checkbox"/> <input type="checkbox"/></p> <p><b>300 outrigger front R+L</b></p> <p>301 transportation safety device    <input type="checkbox"/> <input type="checkbox"/> <input type="checkbox"/> <input type="checkbox"/> <input type="checkbox"/></p> <p>302 outrigger    <input type="checkbox"/> <input type="checkbox"/> <input type="checkbox"/> <input type="checkbox"/> <input type="checkbox"/></p> <p>303 extension box    <input type="checkbox"/> <input type="checkbox"/> <input type="checkbox"/> <input type="checkbox"/> <input type="checkbox"/></p> <p>304 locking device    <input type="checkbox"/> <input type="checkbox"/> <input type="checkbox"/> <input type="checkbox"/> <input type="checkbox"/></p> <p>305 slewing bearing    <input type="checkbox"/> <input type="checkbox"/> <input type="checkbox"/> <input type="checkbox"/> <input type="checkbox"/></p> <p>306 turn locking device    <input type="checkbox"/> <input type="checkbox"/> <input type="checkbox"/> <input type="checkbox"/> <input type="checkbox"/></p> <p>307 support safeguard    <input type="checkbox"/> <input type="checkbox"/> <input type="checkbox"/> <input type="checkbox"/> <input type="checkbox"/></p> <p>308 support plate    <input type="checkbox"/> <input type="checkbox"/> <input type="checkbox"/> <input type="checkbox"/> <input type="checkbox"/></p> <p>309 fixing of jack cylinder    <input type="checkbox"/> <input type="checkbox"/> <input type="checkbox"/> <input type="checkbox"/> <input type="checkbox"/></p> <p>310 jack cylinder    <input type="checkbox"/> <input type="checkbox"/> <input type="checkbox"/> <input type="checkbox"/> <input type="checkbox"/></p>	<p>311 swing cylinder    <input type="checkbox"/> <input type="checkbox"/> <input type="checkbox"/> <input type="checkbox"/> <input type="checkbox"/></p> <p>312 telescopic-cylinder    <input type="checkbox"/> <input type="checkbox"/> <input type="checkbox"/> <input type="checkbox"/> <input type="checkbox"/></p> <p>313 pressure adjustment    <input type="checkbox"/> <input type="checkbox"/> <input type="checkbox"/> <input type="checkbox"/> <input type="checkbox"/></p> <p><b>400 outrigger rear L+R</b></p> <p>401 transportation safety device    <input type="checkbox"/> <input type="checkbox"/> <input type="checkbox"/> <input type="checkbox"/> <input type="checkbox"/></p> <p>402 outrigger    <input type="checkbox"/> <input type="checkbox"/> <input type="checkbox"/> <input type="checkbox"/> <input type="checkbox"/></p> <p>403 extension box    <input type="checkbox"/> <input type="checkbox"/> <input type="checkbox"/> <input type="checkbox"/> <input type="checkbox"/></p> <p>405 locking device    <input type="checkbox"/> <input type="checkbox"/> <input type="checkbox"/> <input type="checkbox"/> <input type="checkbox"/></p> <p>Notes:</p> <hr/> <hr/> <hr/> <hr/> <hr/>
--	--

# Inspection report for concrete booms

Inspection report Nr: \_\_\_\_\_ Boom type: \_\_\_\_\_ Machine-Nr: \_\_\_\_\_

**Error code:**

- |                  |                     |                   |                          |
|------------------|---------------------|-------------------|--------------------------|
| 00 no objections | 08 corrosion        | 16 porous         | 24 deformation           |
| 01 cracks        | 09 lacquer failures | 17 burned through | 25 bear movement         |
| 02 broken        | 10 fraying          | 18 not fixed      | 26 lubrication           |
| 03 leaky         | 11 scratched        | 19 clomp          | 27 readability           |
| 04 no function   | 12 bendet           | 20 sawing         | 28 missing components    |
| 05 low lifetime  | 13 noises           | 21 contaminated   | 29 hydraulical           |
| 06 worn out      | 14 vibration        | 22 bad contact    | 30 electrical            |
| 07 dirt          | 15 miscellaneous    | 23 temperature    | 31 reinspection required |

<p>406 slewing bearing <input type="checkbox"/> <input type="checkbox"/> <input type="checkbox"/> <input type="checkbox"/> <input type="checkbox"/></p> <p>407 turn locking device <input type="checkbox"/> <input type="checkbox"/> <input type="checkbox"/> <input type="checkbox"/> <input type="checkbox"/></p> <p>408 support safeguard <input type="checkbox"/> <input type="checkbox"/> <input type="checkbox"/> <input type="checkbox"/> <input type="checkbox"/></p> <p>409 support plate <input type="checkbox"/> <input type="checkbox"/> <input type="checkbox"/> <input type="checkbox"/> <input type="checkbox"/></p> <p>410 fixing of jack cylinder <input type="checkbox"/> <input type="checkbox"/> <input type="checkbox"/> <input type="checkbox"/> <input type="checkbox"/></p> <p>411 jack cylinder <input type="checkbox"/> <input type="checkbox"/> <input type="checkbox"/> <input type="checkbox"/> <input type="checkbox"/></p> <p>412 swing cylinder <input type="checkbox"/> <input type="checkbox"/> <input type="checkbox"/> <input type="checkbox"/> <input type="checkbox"/></p> <p>413 telescopic cylinder <input type="checkbox"/> <input type="checkbox"/> <input type="checkbox"/> <input type="checkbox"/> <input type="checkbox"/></p> <p><b>500 pedestal</b></p> <p>501 pedestal mounting <input type="checkbox"/> <input type="checkbox"/> <input type="checkbox"/> <input type="checkbox"/> <input type="checkbox"/></p> <p>502 sub frame <input type="checkbox"/> <input type="checkbox"/> <input type="checkbox"/> <input type="checkbox"/> <input type="checkbox"/></p> <p>503 truck frame <input type="checkbox"/> <input type="checkbox"/> <input type="checkbox"/> <input type="checkbox"/> <input type="checkbox"/></p> <p>504 pedestal (structure) <input type="checkbox"/> <input type="checkbox"/> <input type="checkbox"/> <input type="checkbox"/> <input type="checkbox"/></p> <p>505 boom valve without leaking <input type="checkbox"/> <input type="checkbox"/> <input type="checkbox"/> <input type="checkbox"/> <input type="checkbox"/></p> <p>506 boom rest <input type="checkbox"/> <input type="checkbox"/> <input type="checkbox"/> <input type="checkbox"/> <input type="checkbox"/></p> <p>507 transportation safety device <input type="checkbox"/> <input type="checkbox"/> <input type="checkbox"/> <input type="checkbox"/> <input type="checkbox"/></p> <p>508 hydraulic line <input type="checkbox"/> <input type="checkbox"/> <input type="checkbox"/> <input type="checkbox"/> <input type="checkbox"/></p> <p><b>600 slewing head with ball pivot</b></p> <p>601 slewing head <input type="checkbox"/> <input type="checkbox"/> <input type="checkbox"/> <input type="checkbox"/> <input type="checkbox"/></p> <p>602 ball pivot ring <input type="checkbox"/> <input type="checkbox"/> <input type="checkbox"/> <input type="checkbox"/> <input type="checkbox"/></p> <p>603 mounting ball pivot ring <input type="checkbox"/> <input type="checkbox"/> <input type="checkbox"/> <input type="checkbox"/> <input type="checkbox"/></p> <p>604 drive pinion <input type="checkbox"/> <input type="checkbox"/> <input type="checkbox"/> <input type="checkbox"/> <input type="checkbox"/></p>	<p>605 slewing drive mounting <input type="checkbox"/> <input type="checkbox"/> <input type="checkbox"/> <input type="checkbox"/> <input type="checkbox"/></p> <p>606 slewing stop device <input type="checkbox"/> <input type="checkbox"/> <input type="checkbox"/> <input type="checkbox"/> <input type="checkbox"/></p> <p>607 slewing drive (tooth backlash) <input type="checkbox"/> <input type="checkbox"/> <input type="checkbox"/> <input type="checkbox"/> <input type="checkbox"/></p> <p>608 slewing drive <input type="checkbox"/> <input type="checkbox"/> <input type="checkbox"/> <input type="checkbox"/> <input type="checkbox"/></p> <p>609 brake function <input type="checkbox"/> <input type="checkbox"/> <input type="checkbox"/> <input type="checkbox"/> <input type="checkbox"/></p> <p>610 speed <input type="checkbox"/> <input type="checkbox"/> <input type="checkbox"/> <input type="checkbox"/> <input type="checkbox"/></p> <p>611 pressure setting <input type="checkbox"/> <input type="checkbox"/> <input type="checkbox"/> <input type="checkbox"/> <input type="checkbox"/></p> <p>612 hydraulic lines <input type="checkbox"/> <input type="checkbox"/> <input type="checkbox"/> <input type="checkbox"/> <input type="checkbox"/></p> <p><b>700 slewing head with slewing column</b></p> <p>701 slewing head <input type="checkbox"/> <input type="checkbox"/> <input type="checkbox"/> <input type="checkbox"/> <input type="checkbox"/></p> <p>702 slewing column bearing <input type="checkbox"/> <input type="checkbox"/> <input type="checkbox"/> <input type="checkbox"/> <input type="checkbox"/></p> <p>703 slewing drive (tooth backlash) <input type="checkbox"/> <input type="checkbox"/> <input type="checkbox"/> <input type="checkbox"/> <input type="checkbox"/></p> <p>704 speed <input type="checkbox"/> <input type="checkbox"/> <input type="checkbox"/> <input type="checkbox"/> <input type="checkbox"/></p> <p>705 pressure settings <input type="checkbox"/> <input type="checkbox"/> <input type="checkbox"/> <input type="checkbox"/> <input type="checkbox"/></p> <p>706 hydraulic lines <input type="checkbox"/> <input type="checkbox"/> <input type="checkbox"/> <input type="checkbox"/> <input type="checkbox"/></p> <p>707 swivel cylinder <input type="checkbox"/> <input type="checkbox"/> <input type="checkbox"/> <input type="checkbox"/> <input type="checkbox"/></p> <p>Notes:</p> <hr/> <hr/> <hr/> <hr/>
---	---

# Inspection report for concrete booms

Inspection report Nr:	Boom type:	Machine-Nr:
-----------------------	------------	-------------

- Error code:**
- |                  |                     |                   |                          |
|------------------|---------------------|-------------------|--------------------------|
| 00 no objections | 08 corrosion        | 16 porous         | 24 deformation           |
| 01 cracks        | 09 lacquer failures | 17 burned through | 25 bear movement         |
| 02 broken        | 10 fraying          | 18 not fixed      | 26 lubrication           |
| 03 leaky         | 11 scratched        | 19 clomp          | 27 readability           |
| 04 no function   | 12 bendet           | 20 sawing         | 28 missing components    |
| 05 low lifetime  | 13 noises           | 21 contaminated   | 29 hydraulic             |
| 06 worn out      | 14 vibration        | 22 bad contact    | 30 electrical            |
| 07 dirt          | 15 miscellaneous    | 23 temperature    | 31 reinspection required |

<p><b>800 boom</b></p> <p>801 „Arm 1“ <input type="checkbox"/> <input type="checkbox"/> <input type="checkbox"/> <input type="checkbox"/> <input type="checkbox"/></p> <p>802 bracket conveying line <input type="checkbox"/> <input type="checkbox"/> <input type="checkbox"/> <input type="checkbox"/> <input type="checkbox"/></p> <p>803 Drop hook <input type="checkbox"/> <input type="checkbox"/> <input type="checkbox"/> <input type="checkbox"/> <input type="checkbox"/></p> <p>804 „Arm 2“ <input type="checkbox"/> <input type="checkbox"/> <input type="checkbox"/> <input type="checkbox"/> <input type="checkbox"/></p> <p>805 bracket conveying line <input type="checkbox"/> <input type="checkbox"/> <input type="checkbox"/> <input type="checkbox"/> <input type="checkbox"/></p> <p>806 Drop hook <input type="checkbox"/> <input type="checkbox"/> <input type="checkbox"/> <input type="checkbox"/> <input type="checkbox"/></p> <p>807 „Arm 3“ <input type="checkbox"/> <input type="checkbox"/> <input type="checkbox"/> <input type="checkbox"/> <input type="checkbox"/></p> <p>808 bracket conveying line <input type="checkbox"/> <input type="checkbox"/> <input type="checkbox"/> <input type="checkbox"/> <input type="checkbox"/></p> <p>809 guidance and interlock of the arm <input type="checkbox"/> <input type="checkbox"/> <input type="checkbox"/> <input type="checkbox"/> <input type="checkbox"/></p> <p>810 „Arm 4“ <input type="checkbox"/> <input type="checkbox"/> <input type="checkbox"/> <input type="checkbox"/> <input type="checkbox"/></p> <p>811 bracket conveying line <input type="checkbox"/> <input type="checkbox"/> <input type="checkbox"/> <input type="checkbox"/> <input type="checkbox"/></p> <p>812 guidance and interlock of the arm <input type="checkbox"/> <input type="checkbox"/> <input type="checkbox"/> <input type="checkbox"/> <input type="checkbox"/></p> <p>813 „Arm 5“ <input type="checkbox"/> <input type="checkbox"/> <input type="checkbox"/> <input type="checkbox"/> <input type="checkbox"/></p> <p>814 bracket conveying line <input type="checkbox"/> <input type="checkbox"/> <input type="checkbox"/> <input type="checkbox"/> <input type="checkbox"/></p> <p>815 guidance and interlock of the arm <input type="checkbox"/> <input type="checkbox"/> <input type="checkbox"/> <input type="checkbox"/> <input type="checkbox"/></p> <p><b>900 joint „A“</b></p> <p>901 boom <input type="checkbox"/> <input type="checkbox"/> <input type="checkbox"/> <input type="checkbox"/> <input type="checkbox"/></p> <p>902 link lever <input type="checkbox"/> <input type="checkbox"/> <input type="checkbox"/> <input type="checkbox"/> <input type="checkbox"/></p> <p>903 forcing rod <input type="checkbox"/> <input type="checkbox"/> <input type="checkbox"/> <input type="checkbox"/> <input type="checkbox"/></p> <p>904 pin <input type="checkbox"/> <input type="checkbox"/> <input type="checkbox"/> <input type="checkbox"/> <input type="checkbox"/></p> <p>905 cylinder <input type="checkbox"/> <input type="checkbox"/> <input type="checkbox"/> <input type="checkbox"/> <input type="checkbox"/></p>	<p>906 boom speed <input type="checkbox"/> <input type="checkbox"/> <input type="checkbox"/> <input type="checkbox"/> <input type="checkbox"/></p> <p>907 pressure settings <input type="checkbox"/> <input type="checkbox"/> <input type="checkbox"/> <input type="checkbox"/> <input type="checkbox"/></p> <p>908 hydraulic lines <input type="checkbox"/> <input type="checkbox"/> <input type="checkbox"/> <input type="checkbox"/> <input type="checkbox"/></p> <p>909 load holding valve (piston side) <input type="checkbox"/> <input type="checkbox"/> <input type="checkbox"/> <input type="checkbox"/> <input type="checkbox"/></p> <p>910 load holding valve (rod side) <input type="checkbox"/> <input type="checkbox"/> <input type="checkbox"/> <input type="checkbox"/> <input type="checkbox"/></p> <p><b>1000 joint „B“</b></p> <p>1001 boom <input type="checkbox"/> <input type="checkbox"/> <input type="checkbox"/> <input type="checkbox"/> <input type="checkbox"/></p> <p>1002 link lever <input type="checkbox"/> <input type="checkbox"/> <input type="checkbox"/> <input type="checkbox"/> <input type="checkbox"/></p> <p>1003 forcing rod <input type="checkbox"/> <input type="checkbox"/> <input type="checkbox"/> <input type="checkbox"/> <input type="checkbox"/></p> <p>1004 pin <input type="checkbox"/> <input type="checkbox"/> <input type="checkbox"/> <input type="checkbox"/> <input type="checkbox"/></p> <p>1005 cylinder <input type="checkbox"/> <input type="checkbox"/> <input type="checkbox"/> <input type="checkbox"/> <input type="checkbox"/></p> <p>1006 boom speed <input type="checkbox"/> <input type="checkbox"/> <input type="checkbox"/> <input type="checkbox"/> <input type="checkbox"/></p> <p>1007 pressure settings <input type="checkbox"/> <input type="checkbox"/> <input type="checkbox"/> <input type="checkbox"/> <input type="checkbox"/></p> <p>1008 hydraulic lines <input type="checkbox"/> <input type="checkbox"/> <input type="checkbox"/> <input type="checkbox"/> <input type="checkbox"/></p> <p>1009 load holding valve (piston side) <input type="checkbox"/> <input type="checkbox"/> <input type="checkbox"/> <input type="checkbox"/> <input type="checkbox"/></p> <p>1010 load holding valve (rod side) <input type="checkbox"/> <input type="checkbox"/> <input type="checkbox"/> <input type="checkbox"/> <input type="checkbox"/></p> <p>Notes:</p> <hr/> <hr/> <hr/> <hr/>
--	---

# Inspection report for concrete booms

Inspection report Nr: \_\_\_\_\_ Boom type: \_\_\_\_\_ Machine-Nr: \_\_\_\_\_

Error code:			
00 no objections	08 corrosion	16 porous	24 deformation
01 cracks	09 lacquer failures	17 burned through	25 bear movement
02 broken	10 fraying	18 not fixed	26 lubrication
03 leaky	11 scratched	19 clemp	27 readability
04 no function	12 bendet	20 sawing	28 missing components
05 low lifetime	13 noises	21 contaminated	29 hydraulical
06 worn out	14 vibration	22 bad contact	30 electrical
07 dirt	15 miscellaneous	23 temperature	31 reinspection required

**1100 joint "C"**

1101 boom	<input type="checkbox"/>	<input type="checkbox"/>	<input type="checkbox"/>	<input type="checkbox"/>	<input type="checkbox"/>
1102 link lever	<input type="checkbox"/>	<input type="checkbox"/>	<input type="checkbox"/>	<input type="checkbox"/>	<input type="checkbox"/>
1103 forcing rod	<input type="checkbox"/>	<input type="checkbox"/>	<input type="checkbox"/>	<input type="checkbox"/>	<input type="checkbox"/>
1104 pin	<input type="checkbox"/>	<input type="checkbox"/>	<input type="checkbox"/>	<input type="checkbox"/>	<input type="checkbox"/>
1105 cylinder	<input type="checkbox"/>	<input type="checkbox"/>	<input type="checkbox"/>	<input type="checkbox"/>	<input type="checkbox"/>
1106 boom speed	<input type="checkbox"/>	<input type="checkbox"/>	<input type="checkbox"/>	<input type="checkbox"/>	<input type="checkbox"/>
1107 pressure settings	<input type="checkbox"/>	<input type="checkbox"/>	<input type="checkbox"/>	<input type="checkbox"/>	<input type="checkbox"/>
1108 hydraulic lines	<input type="checkbox"/>	<input type="checkbox"/>	<input type="checkbox"/>	<input type="checkbox"/>	<input type="checkbox"/>
1109 load holding valve (piston side)	<input type="checkbox"/>	<input type="checkbox"/>	<input type="checkbox"/>	<input type="checkbox"/>	<input type="checkbox"/>
1110 load holding valve (rod side)	<input type="checkbox"/>	<input type="checkbox"/>	<input type="checkbox"/>	<input type="checkbox"/>	<input type="checkbox"/>

**1200 joint "D"**

1201 boom	<input type="checkbox"/>	<input type="checkbox"/>	<input type="checkbox"/>	<input type="checkbox"/>	<input type="checkbox"/>
1202 link lever	<input type="checkbox"/>	<input type="checkbox"/>	<input type="checkbox"/>	<input type="checkbox"/>	<input type="checkbox"/>
1203 forcing rod	<input type="checkbox"/>	<input type="checkbox"/>	<input type="checkbox"/>	<input type="checkbox"/>	<input type="checkbox"/>
1204 pin	<input type="checkbox"/>	<input type="checkbox"/>	<input type="checkbox"/>	<input type="checkbox"/>	<input type="checkbox"/>
1205 cylinder	<input type="checkbox"/>	<input type="checkbox"/>	<input type="checkbox"/>	<input type="checkbox"/>	<input type="checkbox"/>
1206 boom speed	<input type="checkbox"/>	<input type="checkbox"/>	<input type="checkbox"/>	<input type="checkbox"/>	<input type="checkbox"/>
1207 pressure settings	<input type="checkbox"/>	<input type="checkbox"/>	<input type="checkbox"/>	<input type="checkbox"/>	<input type="checkbox"/>
1208 hydraulic lines	<input type="checkbox"/>	<input type="checkbox"/>	<input type="checkbox"/>	<input type="checkbox"/>	<input type="checkbox"/>
1209 load holding valve (piston side)	<input type="checkbox"/>	<input type="checkbox"/>	<input type="checkbox"/>	<input type="checkbox"/>	<input type="checkbox"/>
1210 load holding valve (rod side)	<input type="checkbox"/>	<input type="checkbox"/>	<input type="checkbox"/>	<input type="checkbox"/>	<input type="checkbox"/>

**1300 joint „E“**

1301 boom	<input type="checkbox"/>	<input type="checkbox"/>	<input type="checkbox"/>	<input type="checkbox"/>	<input type="checkbox"/>
1302 link lever	<input type="checkbox"/>	<input type="checkbox"/>	<input type="checkbox"/>	<input type="checkbox"/>	<input type="checkbox"/>
1303 forcing rod	<input type="checkbox"/>	<input type="checkbox"/>	<input type="checkbox"/>	<input type="checkbox"/>	<input type="checkbox"/>
1304 pin	<input type="checkbox"/>	<input type="checkbox"/>	<input type="checkbox"/>	<input type="checkbox"/>	<input type="checkbox"/>
1305 cylinder	<input type="checkbox"/>	<input type="checkbox"/>	<input type="checkbox"/>	<input type="checkbox"/>	<input type="checkbox"/>
1306 boom speed	<input type="checkbox"/>	<input type="checkbox"/>	<input type="checkbox"/>	<input type="checkbox"/>	<input type="checkbox"/>
1307 pressure settings	<input type="checkbox"/>	<input type="checkbox"/>	<input type="checkbox"/>	<input type="checkbox"/>	<input type="checkbox"/>
1308 hydraulic lines	<input type="checkbox"/>	<input type="checkbox"/>	<input type="checkbox"/>	<input type="checkbox"/>	<input type="checkbox"/>
1309 load holding valve (piston side)	<input type="checkbox"/>	<input type="checkbox"/>	<input type="checkbox"/>	<input type="checkbox"/>	<input type="checkbox"/>
1310 load holding valve (rod side)	<input type="checkbox"/>	<input type="checkbox"/>	<input type="checkbox"/>	<input type="checkbox"/>	<input type="checkbox"/>

**1400 concrete delivery line**

1401 assembly of delivery line DN	<input type="checkbox"/>	<input type="checkbox"/>	<input type="checkbox"/>	<input type="checkbox"/>	<input type="checkbox"/>
1402 end hose DN+lenght	<input type="checkbox"/>	<input type="checkbox"/>	<input type="checkbox"/>	<input type="checkbox"/>	<input type="checkbox"/>
1403 delivery line DN	<input type="checkbox"/>	<input type="checkbox"/>	<input type="checkbox"/>	<input type="checkbox"/>	<input type="checkbox"/>
1404 rotating joints of - delivery line	<input type="checkbox"/>	<input type="checkbox"/>	<input type="checkbox"/>	<input type="checkbox"/>	<input type="checkbox"/>
1405 locking pin of the coupling	<input type="checkbox"/>	<input type="checkbox"/>	<input type="checkbox"/>	<input type="checkbox"/>	<input type="checkbox"/>

Notes:

## Inspection report for concrete booms

Page 5-5

Inspection report Nr: \_\_\_\_\_ Boom type: \_\_\_\_\_ Machine-Nr: \_\_\_\_\_

**Error code:**

- |                  |                     |                   |                          |
|------------------|---------------------|-------------------|--------------------------|
| 00 no objections | 08 corrosion        | 16 porous         | 24 deformation           |
| 01 cracks        | 09 lacquer failures | 17 burned through | 25 bear movement         |
| 02 broken        | 10 fraying          | 18 not fixed      | 26 lubrication           |
| 03 leaky         | 11 scratched        | 19 clemp          | 27 readability           |
| 04 no function   | 12 bendet           | 20 sawing         | 28 missing components    |
| 05 low lifetime  | 13 noises           | 21 contaminated   | 29 hydraulical           |
| 06 worn out      | 14 vibration        | 22 bad contact    | 30 electrical            |
| 07 dirt          | 15 miscellaneous    | 23 temperature    | 31 reinspection required |

<p>1406 end hose safety device <input type="checkbox"/> <input type="checkbox"/> <input type="checkbox"/> <input type="checkbox"/> <input type="checkbox"/></p> <p>1407 reducer <input type="checkbox"/> <input type="checkbox"/> <input type="checkbox"/> <input type="checkbox"/> <input type="checkbox"/></p> <p>1408 gate elbow, elbow 6" <input type="checkbox"/> <input type="checkbox"/> <input type="checkbox"/> <input type="checkbox"/> <input type="checkbox"/></p> <p><b>1500 hydraulic system and hydraulic valves</b></p> <p>1501 Pressure relief valve <input type="checkbox"/> <input type="checkbox"/> <input type="checkbox"/> <input type="checkbox"/> <input type="checkbox"/></p> <p>1502 pressure settings <input type="checkbox"/> <input type="checkbox"/> <input type="checkbox"/> <input type="checkbox"/> <input type="checkbox"/></p> <p>1503 hydraulic lines <input type="checkbox"/> <input type="checkbox"/> <input type="checkbox"/> <input type="checkbox"/> <input type="checkbox"/></p> <p>1504 hand operating- (function) <input type="checkbox"/> <input type="checkbox"/> <input type="checkbox"/> <input type="checkbox"/> <input type="checkbox"/></p> <p>1505 boom control valve <input type="checkbox"/> <input type="checkbox"/> <input type="checkbox"/> <input type="checkbox"/> <input type="checkbox"/></p> <p>1506 hydraulic pump <input type="checkbox"/> <input type="checkbox"/> <input type="checkbox"/> <input type="checkbox"/> <input type="checkbox"/></p> <p><b>1600 electric equipment</b></p> <p>1601 remote control (functions) <input type="checkbox"/> <input type="checkbox"/> <input type="checkbox"/> <input type="checkbox"/> <input type="checkbox"/></p> <p>1602 emergency stop (function) <input type="checkbox"/> <input type="checkbox"/> <input type="checkbox"/> <input type="checkbox"/> <input type="checkbox"/></p> <p>1603 switch for outrigger function <input type="checkbox"/> <input type="checkbox"/> <input type="checkbox"/> <input type="checkbox"/> <input type="checkbox"/></p> <p>1604 switch for boom function <input type="checkbox"/> <input type="checkbox"/> <input type="checkbox"/> <input type="checkbox"/> <input type="checkbox"/></p> <p>1605 wiring harness <input type="checkbox"/> <input type="checkbox"/> <input type="checkbox"/> <input type="checkbox"/> <input type="checkbox"/></p> <p>1606 central lubrication <input type="checkbox"/> <input type="checkbox"/> <input type="checkbox"/> <input type="checkbox"/> <input type="checkbox"/></p>	<p><b>1700 sticker sets</b></p> <p>1701 safety hints <input type="checkbox"/> <input type="checkbox"/> <input type="checkbox"/> <input type="checkbox"/> <input type="checkbox"/></p> <p>1702 description <input type="checkbox"/> <input type="checkbox"/> <input type="checkbox"/> <input type="checkbox"/> <input type="checkbox"/></p> <p>1703 operating <input type="checkbox"/> <input type="checkbox"/> <input type="checkbox"/> <input type="checkbox"/> <input type="checkbox"/></p> <p>1704 short operating instruction <input type="checkbox"/> <input type="checkbox"/> <input type="checkbox"/> <input type="checkbox"/> <input type="checkbox"/></p> <p>1705 sticker „ don't use the boom as crane" <input type="checkbox"/> <input type="checkbox"/> <input type="checkbox"/> <input type="checkbox"/> <input type="checkbox"/></p> <p>1706 sticker „guideline operating with boom- and concrete pump" <input type="checkbox"/> <input type="checkbox"/> <input type="checkbox"/> <input type="checkbox"/> <input type="checkbox"/></p> <p>1707 name plate <input type="checkbox"/> <input type="checkbox"/> <input type="checkbox"/> <input type="checkbox"/> <input type="checkbox"/></p> <p>1708 sticker „danger high voltage" <input type="checkbox"/> <input type="checkbox"/> <input type="checkbox"/> <input type="checkbox"/> <input type="checkbox"/></p> <p><b>Competent inspector:</b></p> <p>Date: _____</p> <p>Name: _____</p> <p>Signature: _____ (stamp)</p> <p><b>Customer:</b></p> <p>Signature: _____ (stamp)</p>
---	--

# Inspection report for concrete pump

Inspection report Nr:	Machine-Nr:	Hours of operation:
		Concrete output m <sup>3</sup> :
Company:	Post code:	City:

NL	WV
----	----

**Proof – Result of the tests**

without defects	defects	reinspection required	shut down
<input type="checkbox"/>	<input type="checkbox"/>	<input type="checkbox"/>	<input type="checkbox"/>

Reinspection until date: .....

**Error code:**

- |                  |                     |                   |                          |
|------------------|---------------------|-------------------|--------------------------|
| 00 no objections | 08 corrosion        | 16 porous         | 24 deformation           |
| 01 cracks        | 09 lacquer failures | 17 burned through | 25 bear movement         |
| 02 broken        | 10 fraying          | 18 not fixed      | 26 lubrication           |
| 03 leaky         | 11 scratched        | 19 clomp          | 27 readability           |
| 04 no fuction    | 12 bendet           | 20 sawing         | 28 missing components    |
| 05 low livetime  | 13 noises           | 21 contaminated   | 29 hydraulical           |
| 06 worn out      | 14 vibration        | 22 bad contact    | 30 electrical            |
| 07 dirt          | 15 miscellaneous    | 23 temperature    | 31 reinspection required |

**2000 documents**

2001 operating manual	<input type="checkbox"/>	<input type="checkbox"/>	<input type="checkbox"/>	<input type="checkbox"/>	<input type="checkbox"/>
2002 spare parts list	<input type="checkbox"/>	<input type="checkbox"/>	<input type="checkbox"/>	<input type="checkbox"/>	<input type="checkbox"/>

**2100 drive assembly**

2101 coupling and flange	<input type="checkbox"/>	<input type="checkbox"/>	<input type="checkbox"/>	<input type="checkbox"/>	<input type="checkbox"/>
--------------------------	--------------------------	--------------------------	--------------------------	--------------------------	--------------------------

**2200 gear box**

<input type="checkbox"/>	<input type="checkbox"/>	<input type="checkbox"/>	<input type="checkbox"/>	<input type="checkbox"/>
--------------------------	--------------------------	--------------------------	--------------------------	--------------------------

**2300 hydraulic pump (main)**

<input type="checkbox"/>	<input type="checkbox"/>	<input type="checkbox"/>	<input type="checkbox"/>	<input type="checkbox"/>
--------------------------	--------------------------	--------------------------	--------------------------	--------------------------

**2400 oil-tank**

<input type="checkbox"/>	<input type="checkbox"/>	<input type="checkbox"/>	<input type="checkbox"/>	<input type="checkbox"/>
--------------------------	--------------------------	--------------------------	--------------------------	--------------------------

**2500 drive shaft**

<input type="checkbox"/>	<input type="checkbox"/>	<input type="checkbox"/>	<input type="checkbox"/>	<input type="checkbox"/>
--------------------------	--------------------------	--------------------------	--------------------------	--------------------------

**2700 hydraulic control system**

2701 pressure relief valve	<input type="checkbox"/>	<input type="checkbox"/>	<input type="checkbox"/>	<input type="checkbox"/>	<input type="checkbox"/>
----------------------------	--------------------------	--------------------------	--------------------------	--------------------------	--------------------------

2702 pressure setting	<input type="checkbox"/>	<input type="checkbox"/>	<input type="checkbox"/>	<input type="checkbox"/>	<input type="checkbox"/>
-----------------------	--------------------------	--------------------------	--------------------------	--------------------------	--------------------------

2703 hydraulic line	<input type="checkbox"/>	<input type="checkbox"/>	<input type="checkbox"/>	<input type="checkbox"/>	<input type="checkbox"/>
---------------------	--------------------------	--------------------------	--------------------------	--------------------------	--------------------------

2704 mechanical operation by hand	<input type="checkbox"/>	<input type="checkbox"/>	<input type="checkbox"/>	<input type="checkbox"/>	<input type="checkbox"/>
-----------------------------------	--------------------------	--------------------------	--------------------------	--------------------------	--------------------------

2800 oil –cooler	<input type="checkbox"/>	<input type="checkbox"/>	<input type="checkbox"/>	<input type="checkbox"/>	<input type="checkbox"/>
------------------	--------------------------	--------------------------	--------------------------	--------------------------	--------------------------

2900 accumulator	<input type="checkbox"/>	<input type="checkbox"/>	<input type="checkbox"/>	<input type="checkbox"/>	<input type="checkbox"/>
------------------	--------------------------	--------------------------	--------------------------	--------------------------	--------------------------

2901 proofs of the required tests according to accumulator regulation	<input type="checkbox"/>	<input type="checkbox"/>	<input type="checkbox"/>	<input type="checkbox"/>	<input type="checkbox"/>
---	--------------------------	--------------------------	--------------------------	--------------------------	--------------------------

2902 pressure gauge	<input type="checkbox"/>	<input type="checkbox"/>	<input type="checkbox"/>	<input type="checkbox"/>	<input type="checkbox"/>
---------------------	--------------------------	--------------------------	--------------------------	--------------------------	--------------------------

Notes:



# Inspection report for concrete pump

Inspection report Nr: \_\_\_\_\_ Machine-Nr: \_\_\_\_\_

**Error code:**

- |                  |                     |                   |                          |
|------------------|---------------------|-------------------|--------------------------|
| 00 no objections | 08 corrosion        | 16 porous         | 24 deformation           |
| 01 cracks        | 09 lacquer failures | 17 burned through | 25 bear movement         |
| 02 broken        | 10 fraying          | 18 not fixed      | 26 lubrication           |
| 03 leaky         | 11 scratched        | 19 clemp          | 27 readability           |
| 04 no function   | 12 bendet           | 20 sawing         | 28 missing components    |
| 05 low lifetime  | 13 noises           | 21 contamitated   | 29 hydraulical           |
| 06 worn out      | 14 vibration        | 22 bad contact    | 30 electrical            |
| 07 dirt          | 15 miscellaneous    | 23 temperature    | 31 reinspection required |

- |                                 |  |
|---------------------------------|--|
| <b>3000 central lubrication</b> | <input type="checkbox"/> <input type="checkbox"/> <input type="checkbox"/> <input type="checkbox"/> <input type="checkbox"/> |
| <b>3100 hydraulic motor</b>     | <input type="checkbox"/> <input type="checkbox"/> <input type="checkbox"/> <input type="checkbox"/> <input type="checkbox"/> |
| <b>3200 hydraulic lines</b>     | <input type="checkbox"/> <input type="checkbox"/> <input type="checkbox"/> <input type="checkbox"/> <input type="checkbox"/> |
| <b>3300 air compressor</b>      | <input type="checkbox"/> <input type="checkbox"/> <input type="checkbox"/> <input type="checkbox"/> <input type="checkbox"/> |
| <b>3400 control panel</b>       | <input type="checkbox"/> <input type="checkbox"/> <input type="checkbox"/> <input type="checkbox"/> <input type="checkbox"/> |
| <b>3500 concrete pump</b>       | <input type="checkbox"/> <input type="checkbox"/> <input type="checkbox"/> <input type="checkbox"/> <input type="checkbox"/> |
| <b>3700 S-valve</b>             | <input type="checkbox"/> <input type="checkbox"/> <input type="checkbox"/> <input type="checkbox"/> <input type="checkbox"/> |
| <b>3800 hopper</b>              | <input type="checkbox"/> <input type="checkbox"/> <input type="checkbox"/> <input type="checkbox"/> <input type="checkbox"/> |
| <b>4100 sub frame</b>           | <input type="checkbox"/> <input type="checkbox"/> <input type="checkbox"/> <input type="checkbox"/> <input type="checkbox"/> |
| <b>4200 water tank</b>          | <input type="checkbox"/> <input type="checkbox"/> <input type="checkbox"/> <input type="checkbox"/> <input type="checkbox"/> |
| <b>4300 axle</b>                | <input type="checkbox"/> <input type="checkbox"/> <input type="checkbox"/> <input type="checkbox"/> <input type="checkbox"/> |
| <b>4400 water pump</b>          | <input type="checkbox"/> <input type="checkbox"/> <input type="checkbox"/> <input type="checkbox"/> <input type="checkbox"/> |
| <b>4500 vibrator</b>            | <input type="checkbox"/> <input type="checkbox"/> <input type="checkbox"/> <input type="checkbox"/> <input type="checkbox"/> |

**4600 safety guards, equipment**

- |  |  |
|--|--|
| 4601 stair                                       | <input type="checkbox"/> <input type="checkbox"/> <input type="checkbox"/> <input type="checkbox"/> <input type="checkbox"/> |
| 4602 safety for stair                            | <input type="checkbox"/> <input type="checkbox"/> <input type="checkbox"/> <input type="checkbox"/> <input type="checkbox"/> |
| 4603 handrail                                    | <input type="checkbox"/> <input type="checkbox"/> <input type="checkbox"/> <input type="checkbox"/> <input type="checkbox"/> |
| 4604 hopper grid<br>(fixing device)              | <input type="checkbox"/> <input type="checkbox"/> <input type="checkbox"/> <input type="checkbox"/> <input type="checkbox"/> |
| 4606 distance of grid rods                       | <input type="checkbox"/> <input type="checkbox"/> <input type="checkbox"/> <input type="checkbox"/> <input type="checkbox"/> |
| 4607 distance from grid to<br>agitator           | <input type="checkbox"/> <input type="checkbox"/> <input type="checkbox"/> <input type="checkbox"/> <input type="checkbox"/> |
| 4609 agitator have to stop<br>if grid is open    | <input type="checkbox"/> <input type="checkbox"/> <input type="checkbox"/> <input type="checkbox"/> <input type="checkbox"/> |
| 4610 accumulator have to<br>dump if grid is open | <input type="checkbox"/> <input type="checkbox"/> <input type="checkbox"/> <input type="checkbox"/> <input type="checkbox"/> |
| 4612 cleaning flap hopper                        | <input type="checkbox"/> <input type="checkbox"/> <input type="checkbox"/> <input type="checkbox"/> <input type="checkbox"/> |
| 4613 safety grid into water<br>box               | <input type="checkbox"/> <input type="checkbox"/> <input type="checkbox"/> <input type="checkbox"/> <input type="checkbox"/> |

Notes:

## Inspection report for concrete pump

Page 3-3

Inspection report Nr:

Machine-Nr:

Error code:

00 no objections	08 corrosion	16 porous	24 deformation
01 cracks	09 lacquer failures	17 burned through	25 bear movement
02 broken	10 fraying	18 not fixed	26 lubrication
03 leaky	11 scratched	19 clemp	27 readability
04 no function	12 bendet	20 sawing	28 missing components
05 low lifetime	13 noises	21 contamitated	29 hydraulical
06 worn out	14 vibration	22 bad contact	30 electrical
07 dirt	15 miscellaneous	23 temperature	31 reinspection required

4614 cover for rotating wave

4616 cover for chains

4617 cover for shift cylinder

4618 cover for moving parts

4619 cover for the exhaust pipe

**4700 electrical system**

4701 function of actuator component

4702 emergency stop function

4703 ground connections

4704 cables and wiring harness

4705 temperature switch

**4800 outrigger - system**

4801 transportation lock

4802 locking device

4803 backing plate

4804 jack cylinder connections

4805 pressure adjustment of jack cylinder

**4900 miscellaneous**

4901 additional assembled part from operator

4902 changes through operator

**Competent inspector:**

Date: .....

Name: .....

Signature: .....  
(stamp)

**Customer:**

Signature: .....  
(stamp)

**This test report is filed into the test book**

# Inspection report for concrete booms

Inspection report -Nr:	Machine-Nr	Hours of operation:
		Concrete output m <sup>3</sup> :
Company:	Post code:	City:
Boom Type:	Boom Nr.	NL <span style="margin-left: 100px;">WV</span>

**Proof – Result of the Tests**

without defects	defects	reinspection required	shut down
<input type="checkbox"/>	<input type="checkbox"/>	<input type="checkbox"/>	<input type="checkbox"/>

Reinspection until date: .....

**Error code:**

- |                  |                     |                   |                          |
|------------------|---------------------|-------------------|--------------------------|
| 00 no objections | 08 corrosion        | 16 porous         | 24 deformation           |
| 01 cracks        | 09 lacquer failures | 17 burned through | 25 bear movement         |
| 02 broken        | 10 fraying          | 18 not fixed      | 26 lubrication           |
| 03 leaky         | 11 scratched        | 19 clemp          | 27 readability           |
| 04 no function   | 12 bendet           | 20 sawing         | 28 missing components    |
| 05 low lifetime  | 13 noises           | 21 contaminated   | 29 hydraulic             |
| 06 worn out      | 14 vibration        | 22 bad contact    | 30 electrical            |
| 07 dirt          | 15 miscellaneous    | 23 temperature    | 31 reinspection required |

<p><b>100 documents</b></p> <p>101 instruction manual <input type="checkbox"/> <input type="checkbox"/> <input type="checkbox"/> <input type="checkbox"/> <input type="checkbox"/></p> <p>102 spare parts list <input type="checkbox"/> <input type="checkbox"/> <input type="checkbox"/> <input type="checkbox"/> <input type="checkbox"/></p> <p><b>200 sub frame</b></p> <p>201 frame connection cpl. <input type="checkbox"/> <input type="checkbox"/> <input type="checkbox"/> <input type="checkbox"/> <input type="checkbox"/></p> <p><b>300 outrigger front R+L</b></p> <p>301 transportation safety device <input type="checkbox"/> <input type="checkbox"/> <input type="checkbox"/> <input type="checkbox"/> <input type="checkbox"/></p> <p>302 outrigger <input type="checkbox"/> <input type="checkbox"/> <input type="checkbox"/> <input type="checkbox"/> <input type="checkbox"/></p> <p>303 extension box <input type="checkbox"/> <input type="checkbox"/> <input type="checkbox"/> <input type="checkbox"/> <input type="checkbox"/></p> <p>304 locking device <input type="checkbox"/> <input type="checkbox"/> <input type="checkbox"/> <input type="checkbox"/> <input type="checkbox"/></p> <p>305 slewing bearing <input type="checkbox"/> <input type="checkbox"/> <input type="checkbox"/> <input type="checkbox"/> <input type="checkbox"/></p> <p>306 turn locking device <input type="checkbox"/> <input type="checkbox"/> <input type="checkbox"/> <input type="checkbox"/> <input type="checkbox"/></p> <p>307 support safeguard <input type="checkbox"/> <input type="checkbox"/> <input type="checkbox"/> <input type="checkbox"/> <input type="checkbox"/></p> <p>308 support plate <input type="checkbox"/> <input type="checkbox"/> <input type="checkbox"/> <input type="checkbox"/> <input type="checkbox"/></p> <p>309 fixing of jack cylinder <input type="checkbox"/> <input type="checkbox"/> <input type="checkbox"/> <input type="checkbox"/> <input type="checkbox"/></p> <p>310 jack cylinder <input type="checkbox"/> <input type="checkbox"/> <input type="checkbox"/> <input type="checkbox"/> <input type="checkbox"/></p>	<p>311 swing cylinder <input type="checkbox"/> <input type="checkbox"/> <input type="checkbox"/> <input type="checkbox"/> <input type="checkbox"/></p> <p>312 telescopic-cylinder <input type="checkbox"/> <input type="checkbox"/> <input type="checkbox"/> <input type="checkbox"/> <input type="checkbox"/></p> <p>313 pressure adjustment <input type="checkbox"/> <input type="checkbox"/> <input type="checkbox"/> <input type="checkbox"/> <input type="checkbox"/></p> <p><b>400 outrigger rear L+R</b></p> <p>401 transportation safety device <input type="checkbox"/> <input type="checkbox"/> <input type="checkbox"/> <input type="checkbox"/> <input type="checkbox"/></p> <p>402 outrigger <input type="checkbox"/> <input type="checkbox"/> <input type="checkbox"/> <input type="checkbox"/> <input type="checkbox"/></p> <p>403 extension box <input type="checkbox"/> <input type="checkbox"/> <input type="checkbox"/> <input type="checkbox"/> <input type="checkbox"/></p> <p>405 locking device <input type="checkbox"/> <input type="checkbox"/> <input type="checkbox"/> <input type="checkbox"/> <input type="checkbox"/></p> <p>Notes:</p> <hr/> <hr/> <hr/> <hr/> <hr/>
---	---

# Inspection report for concrete booms

Inspection report Nr: \_\_\_\_\_ Boom type: \_\_\_\_\_ Machine-Nr: \_\_\_\_\_

- Error code:**
- |                  |                     |                   |                          |
|------------------|---------------------|-------------------|--------------------------|
| 00 no objections | 08 corrosion        | 16 porous         | 24 deformation           |
| 01 cracks        | 09 lacquer failures | 17 burned through | 25 bear movement         |
| 02 broken        | 10 fraying          | 18 not fixed      | 26 lubrication           |
| 03 leaky         | 11 scratched        | 19 clomp          | 27 readability           |
| 04 no function   | 12 bendet           | 20 sawing         | 28 missing components    |
| 05 low lifetime  | 13 noises           | 21 contaminated   | 29 hydraulical           |
| 06 worn out      | 14 vibration        | 22 bad contact    | 30 electrical            |
| 07 dirt          | 15 miscellaneous    | 23 temperature    | 31 reinspection required |

<p>406 slewing bearing <input type="checkbox"/> <input type="checkbox"/> <input type="checkbox"/> <input type="checkbox"/> <input type="checkbox"/></p> <p>407 turn locking device <input type="checkbox"/> <input type="checkbox"/> <input type="checkbox"/> <input type="checkbox"/> <input type="checkbox"/></p> <p>408 support safeguard <input type="checkbox"/> <input type="checkbox"/> <input type="checkbox"/> <input type="checkbox"/> <input type="checkbox"/></p> <p>409 support plate <input type="checkbox"/> <input type="checkbox"/> <input type="checkbox"/> <input type="checkbox"/> <input type="checkbox"/></p> <p>410 fixing of jack cylinder <input type="checkbox"/> <input type="checkbox"/> <input type="checkbox"/> <input type="checkbox"/> <input type="checkbox"/></p> <p>411 jack cylinder <input type="checkbox"/> <input type="checkbox"/> <input type="checkbox"/> <input type="checkbox"/> <input type="checkbox"/></p> <p>412 swing cylinder <input type="checkbox"/> <input type="checkbox"/> <input type="checkbox"/> <input type="checkbox"/> <input type="checkbox"/></p> <p>413 telescopic cylinder <input type="checkbox"/> <input type="checkbox"/> <input type="checkbox"/> <input type="checkbox"/> <input type="checkbox"/></p> <p><b>500 pedestal</b></p> <p>501 pedestal mounting <input type="checkbox"/> <input type="checkbox"/> <input type="checkbox"/> <input type="checkbox"/> <input type="checkbox"/></p> <p>502 sub frame <input type="checkbox"/> <input type="checkbox"/> <input type="checkbox"/> <input type="checkbox"/> <input type="checkbox"/></p> <p>503 truck frame <input type="checkbox"/> <input type="checkbox"/> <input type="checkbox"/> <input type="checkbox"/> <input type="checkbox"/></p> <p>504 pedestal (structure) <input type="checkbox"/> <input type="checkbox"/> <input type="checkbox"/> <input type="checkbox"/> <input type="checkbox"/></p> <p>505 boom valve without leaking <input type="checkbox"/> <input type="checkbox"/> <input type="checkbox"/> <input type="checkbox"/> <input type="checkbox"/></p> <p>506 boom rest <input type="checkbox"/> <input type="checkbox"/> <input type="checkbox"/> <input type="checkbox"/> <input type="checkbox"/></p> <p>507 transportation safety device <input type="checkbox"/> <input type="checkbox"/> <input type="checkbox"/> <input type="checkbox"/> <input type="checkbox"/></p> <p>508 hydraulic line <input type="checkbox"/> <input type="checkbox"/> <input type="checkbox"/> <input type="checkbox"/> <input type="checkbox"/></p> <p><b>600 slewing head with ball pivot</b></p> <p>601 slewing head <input type="checkbox"/> <input type="checkbox"/> <input type="checkbox"/> <input type="checkbox"/> <input type="checkbox"/></p> <p>602 ball pivot ring <input type="checkbox"/> <input type="checkbox"/> <input type="checkbox"/> <input type="checkbox"/> <input type="checkbox"/></p> <p>603 mounting ball pivot ring <input type="checkbox"/> <input type="checkbox"/> <input type="checkbox"/> <input type="checkbox"/> <input type="checkbox"/></p> <p>604 drive pinion <input type="checkbox"/> <input type="checkbox"/> <input type="checkbox"/> <input type="checkbox"/> <input type="checkbox"/></p>	<p>605 slewing drive mounting <input type="checkbox"/> <input type="checkbox"/> <input type="checkbox"/> <input type="checkbox"/> <input type="checkbox"/></p> <p>606 slewing stop device <input type="checkbox"/> <input type="checkbox"/> <input type="checkbox"/> <input type="checkbox"/> <input type="checkbox"/></p> <p>607 slewing drive (tooth backlash) <input type="checkbox"/> <input type="checkbox"/> <input type="checkbox"/> <input type="checkbox"/> <input type="checkbox"/></p> <p>608 slewing drive <input type="checkbox"/> <input type="checkbox"/> <input type="checkbox"/> <input type="checkbox"/> <input type="checkbox"/></p> <p>609 brake function <input type="checkbox"/> <input type="checkbox"/> <input type="checkbox"/> <input type="checkbox"/> <input type="checkbox"/></p> <p>610 speed <input type="checkbox"/> <input type="checkbox"/> <input type="checkbox"/> <input type="checkbox"/> <input type="checkbox"/></p> <p>611 pressure setting <input type="checkbox"/> <input type="checkbox"/> <input type="checkbox"/> <input type="checkbox"/> <input type="checkbox"/></p> <p>612 hydraulic lines <input type="checkbox"/> <input type="checkbox"/> <input type="checkbox"/> <input type="checkbox"/> <input type="checkbox"/></p> <p><b>700 slewing head with slewing column</b></p> <p>701 slewing head <input type="checkbox"/> <input type="checkbox"/> <input type="checkbox"/> <input type="checkbox"/> <input type="checkbox"/></p> <p>702 slewing column bearing <input type="checkbox"/> <input type="checkbox"/> <input type="checkbox"/> <input type="checkbox"/> <input type="checkbox"/></p> <p>703 slewing drive (tooth backlash) <input type="checkbox"/> <input type="checkbox"/> <input type="checkbox"/> <input type="checkbox"/> <input type="checkbox"/></p> <p>704 speed <input type="checkbox"/> <input type="checkbox"/> <input type="checkbox"/> <input type="checkbox"/> <input type="checkbox"/></p> <p>705 pressure settings <input type="checkbox"/> <input type="checkbox"/> <input type="checkbox"/> <input type="checkbox"/> <input type="checkbox"/></p> <p>706 hydraulic lines <input type="checkbox"/> <input type="checkbox"/> <input type="checkbox"/> <input type="checkbox"/> <input type="checkbox"/></p> <p>707 swivel cylinder <input type="checkbox"/> <input type="checkbox"/> <input type="checkbox"/> <input type="checkbox"/> <input type="checkbox"/></p> <p>Notes:</p> <hr/> <hr/> <hr/> <hr/>
---	---

# Inspection report for concrete booms

Inspection report Nr: \_\_\_\_\_ Boom type: \_\_\_\_\_ Machine-Nr: \_\_\_\_\_

**Error code:**

- |                  |                     |                   |                          |
|------------------|---------------------|-------------------|--------------------------|
| 00 no objections | 08 corrosion        | 16 porous         | 24 deformation           |
| 01 cracks        | 09 lacquer failures | 17 burned through | 25 bear movement         |
| 02 broken        | 10 fraying          | 18 not fixed      | 26 lubrication           |
| 03 leaky         | 11 scratched        | 19 clomp          | 27 readability           |
| 04 no function   | 12 bendet           | 20 sawing         | 28 missing components    |
| 05 low lifetime  | 13 noises           | 21 contaminated   | 29 hydraulical           |
| 06 worn out      | 14 vibration        | 22 bad contact    | 30 electrical            |
| 07 dirt          | 15 miscellaneous    | 23 temperature    | 31 reinspection required |

<p><b>800 boom</b></p> <p>801 „Arm 1“ <input type="checkbox"/> <input type="checkbox"/> <input type="checkbox"/> <input type="checkbox"/> <input type="checkbox"/></p> <p>802 bracket conveying line <input type="checkbox"/> <input type="checkbox"/> <input type="checkbox"/> <input type="checkbox"/> <input type="checkbox"/></p> <p>803 Drop hook <input type="checkbox"/> <input type="checkbox"/> <input type="checkbox"/> <input type="checkbox"/> <input type="checkbox"/></p> <p>804 „Arm 2“ <input type="checkbox"/> <input type="checkbox"/> <input type="checkbox"/> <input type="checkbox"/> <input type="checkbox"/></p> <p>805 bracket conveying line <input type="checkbox"/> <input type="checkbox"/> <input type="checkbox"/> <input type="checkbox"/> <input type="checkbox"/></p> <p>806 Drop hook <input type="checkbox"/> <input type="checkbox"/> <input type="checkbox"/> <input type="checkbox"/> <input type="checkbox"/></p> <p>807 „Arm 3“ <input type="checkbox"/> <input type="checkbox"/> <input type="checkbox"/> <input type="checkbox"/> <input type="checkbox"/></p> <p>808 bracket conveying line <input type="checkbox"/> <input type="checkbox"/> <input type="checkbox"/> <input type="checkbox"/> <input type="checkbox"/></p> <p>809 guidance and interlock of the arm <input type="checkbox"/> <input type="checkbox"/> <input type="checkbox"/> <input type="checkbox"/> <input type="checkbox"/></p> <p>810 „Arm 4“ <input type="checkbox"/> <input type="checkbox"/> <input type="checkbox"/> <input type="checkbox"/> <input type="checkbox"/></p> <p>811 bracket conveying line <input type="checkbox"/> <input type="checkbox"/> <input type="checkbox"/> <input type="checkbox"/> <input type="checkbox"/></p> <p>812 guidance and interlock of the arm <input type="checkbox"/> <input type="checkbox"/> <input type="checkbox"/> <input type="checkbox"/> <input type="checkbox"/></p> <p>813 „Arm 5“ <input type="checkbox"/> <input type="checkbox"/> <input type="checkbox"/> <input type="checkbox"/> <input type="checkbox"/></p> <p>814 bracket conveying line <input type="checkbox"/> <input type="checkbox"/> <input type="checkbox"/> <input type="checkbox"/> <input type="checkbox"/></p> <p>815 guidance and interlock of the arm <input type="checkbox"/> <input type="checkbox"/> <input type="checkbox"/> <input type="checkbox"/> <input type="checkbox"/></p> <p><b>900 joint „A“</b></p> <p>901 boom <input type="checkbox"/> <input type="checkbox"/> <input type="checkbox"/> <input type="checkbox"/> <input type="checkbox"/></p> <p>902 link lever <input type="checkbox"/> <input type="checkbox"/> <input type="checkbox"/> <input type="checkbox"/> <input type="checkbox"/></p> <p>903 forcing rod <input type="checkbox"/> <input type="checkbox"/> <input type="checkbox"/> <input type="checkbox"/> <input type="checkbox"/></p> <p>904 pin <input type="checkbox"/> <input type="checkbox"/> <input type="checkbox"/> <input type="checkbox"/> <input type="checkbox"/></p> <p>905 cylinder <input type="checkbox"/> <input type="checkbox"/> <input type="checkbox"/> <input type="checkbox"/> <input type="checkbox"/></p>	<p>906 boom speed <input type="checkbox"/> <input type="checkbox"/> <input type="checkbox"/> <input type="checkbox"/> <input type="checkbox"/></p> <p>907 pressure settings <input type="checkbox"/> <input type="checkbox"/> <input type="checkbox"/> <input type="checkbox"/> <input type="checkbox"/></p> <p>908 hydraulic lines <input type="checkbox"/> <input type="checkbox"/> <input type="checkbox"/> <input type="checkbox"/> <input type="checkbox"/></p> <p>909 load holding valve (piston side) <input type="checkbox"/> <input type="checkbox"/> <input type="checkbox"/> <input type="checkbox"/> <input type="checkbox"/></p> <p>910 load holding valve (rod side) <input type="checkbox"/> <input type="checkbox"/> <input type="checkbox"/> <input type="checkbox"/> <input type="checkbox"/></p> <p><b>1000 joint „B“</b></p> <p>1001 boom <input type="checkbox"/> <input type="checkbox"/> <input type="checkbox"/> <input type="checkbox"/> <input type="checkbox"/></p> <p>1002 link lever <input type="checkbox"/> <input type="checkbox"/> <input type="checkbox"/> <input type="checkbox"/> <input type="checkbox"/></p> <p>1003 forcing rod <input type="checkbox"/> <input type="checkbox"/> <input type="checkbox"/> <input type="checkbox"/> <input type="checkbox"/></p> <p>1004 pin <input type="checkbox"/> <input type="checkbox"/> <input type="checkbox"/> <input type="checkbox"/> <input type="checkbox"/></p> <p>1005 cylinder <input type="checkbox"/> <input type="checkbox"/> <input type="checkbox"/> <input type="checkbox"/> <input type="checkbox"/></p> <p>1006 boom speed <input type="checkbox"/> <input type="checkbox"/> <input type="checkbox"/> <input type="checkbox"/> <input type="checkbox"/></p> <p>1007 pressure settings <input type="checkbox"/> <input type="checkbox"/> <input type="checkbox"/> <input type="checkbox"/> <input type="checkbox"/></p> <p>1008 hydraulic lines <input type="checkbox"/> <input type="checkbox"/> <input type="checkbox"/> <input type="checkbox"/> <input type="checkbox"/></p> <p>1009 load holding valve (piston side) <input type="checkbox"/> <input type="checkbox"/> <input type="checkbox"/> <input type="checkbox"/> <input type="checkbox"/></p> <p>1010 load holding valve (rod side) <input type="checkbox"/> <input type="checkbox"/> <input type="checkbox"/> <input type="checkbox"/> <input type="checkbox"/></p> <p>Notes:</p> <hr/> <hr/> <hr/> <hr/>
--	---

# Inspection report for concrete booms

Inspection report Nr: \_\_\_\_\_ Boom type: \_\_\_\_\_ Machine-Nr: \_\_\_\_\_

- |                  |                     |                   |                          |
|------------------|---------------------|-------------------|--------------------------|
| Error code:      |                     |                   |                          |
| 00 no objections | 08 corrosion        | 16 porous         | 24 deformation           |
| 01 cracks        | 09 lacquer failures | 17 burned through | 25 bear movement         |
| 02 broken        | 10 fraying          | 18 not fixed      | 26 lubrication           |
| 03 leaky         | 11 scratched        | 19 clomp          | 27 readability           |
| 04 no function   | 12 bendet           | 20 sawing         | 28 missing components    |
| 05 low lifetime  | 13 noises           | 21 contaminated   | 29 hydraulical           |
| 06 worn out      | 14 vibration        | 22 bad contact    | 30 electrical            |
| 07 dirt          | 15 miscellaneous    | 23 temperature    | 31 reinspection required |

<p><b>1100 joint "C"</b></p> <p>1101 boom <input type="checkbox"/> <input type="checkbox"/> <input type="checkbox"/> <input type="checkbox"/> <input type="checkbox"/></p> <p>1102 link lever <input type="checkbox"/> <input type="checkbox"/> <input type="checkbox"/> <input type="checkbox"/> <input type="checkbox"/></p> <p>1103 forcing rod <input type="checkbox"/> <input type="checkbox"/> <input type="checkbox"/> <input type="checkbox"/> <input type="checkbox"/></p> <p>1104 pin <input type="checkbox"/> <input type="checkbox"/> <input type="checkbox"/> <input type="checkbox"/> <input type="checkbox"/></p> <p>1105 cylinder <input type="checkbox"/> <input type="checkbox"/> <input type="checkbox"/> <input type="checkbox"/> <input type="checkbox"/></p> <p>1106 boom speed <input type="checkbox"/> <input type="checkbox"/> <input type="checkbox"/> <input type="checkbox"/> <input type="checkbox"/></p> <p>1107 pressure settings <input type="checkbox"/> <input type="checkbox"/> <input type="checkbox"/> <input type="checkbox"/> <input type="checkbox"/></p> <p>1108 hydraulic lines <input type="checkbox"/> <input type="checkbox"/> <input type="checkbox"/> <input type="checkbox"/> <input type="checkbox"/></p> <p>1109 load holding valve (piston side) <input type="checkbox"/> <input type="checkbox"/> <input type="checkbox"/> <input type="checkbox"/> <input type="checkbox"/></p> <p>1110 load holding valve (rod side) <input type="checkbox"/> <input type="checkbox"/> <input type="checkbox"/> <input type="checkbox"/> <input type="checkbox"/></p> <p><b>1200 joint "D"</b></p> <p>1201 boom <input type="checkbox"/> <input type="checkbox"/> <input type="checkbox"/> <input type="checkbox"/> <input type="checkbox"/></p> <p>1202 link lever <input type="checkbox"/> <input type="checkbox"/> <input type="checkbox"/> <input type="checkbox"/> <input type="checkbox"/></p> <p>1203 forcing rod <input type="checkbox"/> <input type="checkbox"/> <input type="checkbox"/> <input type="checkbox"/> <input type="checkbox"/></p> <p>1204 pin <input type="checkbox"/> <input type="checkbox"/> <input type="checkbox"/> <input type="checkbox"/> <input type="checkbox"/></p> <p>1205 cylinder <input type="checkbox"/> <input type="checkbox"/> <input type="checkbox"/> <input type="checkbox"/> <input type="checkbox"/></p> <p>1206 boom speed <input type="checkbox"/> <input type="checkbox"/> <input type="checkbox"/> <input type="checkbox"/> <input type="checkbox"/></p> <p>1207 pressure settings <input type="checkbox"/> <input type="checkbox"/> <input type="checkbox"/> <input type="checkbox"/> <input type="checkbox"/></p> <p>1208 hydraulic lines <input type="checkbox"/> <input type="checkbox"/> <input type="checkbox"/> <input type="checkbox"/> <input type="checkbox"/></p> <p>1209 load holding valve (piston side) <input type="checkbox"/> <input type="checkbox"/> <input type="checkbox"/> <input type="checkbox"/> <input type="checkbox"/></p> <p>1210 load holding valve (rod side) <input type="checkbox"/> <input type="checkbox"/> <input type="checkbox"/> <input type="checkbox"/> <input type="checkbox"/></p>	<p><b>1300 joint „E“</b></p> <p>1301 boom <input type="checkbox"/> <input type="checkbox"/> <input type="checkbox"/> <input type="checkbox"/> <input type="checkbox"/></p> <p>1302 link lever <input type="checkbox"/> <input type="checkbox"/> <input type="checkbox"/> <input type="checkbox"/> <input type="checkbox"/></p> <p>1303 forcing rod <input type="checkbox"/> <input type="checkbox"/> <input type="checkbox"/> <input type="checkbox"/> <input type="checkbox"/></p> <p>1304 pin <input type="checkbox"/> <input type="checkbox"/> <input type="checkbox"/> <input type="checkbox"/> <input type="checkbox"/></p> <p>1305 cylinder <input type="checkbox"/> <input type="checkbox"/> <input type="checkbox"/> <input type="checkbox"/> <input type="checkbox"/></p> <p>1306 boom speed <input type="checkbox"/> <input type="checkbox"/> <input type="checkbox"/> <input type="checkbox"/> <input type="checkbox"/></p> <p>1307 pressure settings <input type="checkbox"/> <input type="checkbox"/> <input type="checkbox"/> <input type="checkbox"/> <input type="checkbox"/></p> <p>1308 hydraulic lines <input type="checkbox"/> <input type="checkbox"/> <input type="checkbox"/> <input type="checkbox"/> <input type="checkbox"/></p> <p>1309 load holding valve (piston side) <input type="checkbox"/> <input type="checkbox"/> <input type="checkbox"/> <input type="checkbox"/> <input type="checkbox"/></p> <p>1310 load holding valve (rod side) <input type="checkbox"/> <input type="checkbox"/> <input type="checkbox"/> <input type="checkbox"/> <input type="checkbox"/></p> <p><b>1400 concrete delivery line</b></p> <p>1401 assembly of delivery line DN <input type="checkbox"/> <input type="checkbox"/> <input type="checkbox"/> <input type="checkbox"/> <input type="checkbox"/></p> <p>1402 end hose DN+lenght <input type="checkbox"/> <input type="checkbox"/> <input type="checkbox"/> <input type="checkbox"/> <input type="checkbox"/></p> <p>1403 delivery line DN <input type="checkbox"/> <input type="checkbox"/> <input type="checkbox"/> <input type="checkbox"/> <input type="checkbox"/></p> <p>1404 rotating joints of - delivery line <input type="checkbox"/> <input type="checkbox"/> <input type="checkbox"/> <input type="checkbox"/> <input type="checkbox"/></p> <p>1405 locking pin of the coupling <input type="checkbox"/> <input type="checkbox"/> <input type="checkbox"/> <input type="checkbox"/> <input type="checkbox"/></p> <p>Notes:</p> <hr/> <hr/> <hr/>
---	--

## Inspection report for concrete booms

Inspection report Nr: \_\_\_\_\_ Boom type: \_\_\_\_\_ Machine-Nr: \_\_\_\_\_

**Error code:**

00 no objections	08 corrosion	16 porous	24 deformation
01 cracks	09 lacquer failures	17 burned through	25 bear movement
02 broken	10 fraying	18 not fixed	26 lubrication
03 leaky	11 scratched	19 clomp	27 readability
04 no function	12 bendet	20 sawing	28 missing components
05 low lifetime	13 noises	21 contaminated	29 hydraulical
06 worn out	14 vibration	22 bad contact	30 electrical
07 dirt	15 miscellaneous	23 temperature	31 reinspection required

- 1406 end hose safety device
- 1407 reducer
- 1408 gate elbow, elbow 6"

**1500 hydraulic system and hydraulic valves**

- 1501 Pressure relief valve
- 1502 pressure settings
- 1503 hydraulic lines
- 1504 hand operating-(function)
- 1505 boom control valve
- 1506 hydraulic pump

**1600 electric equipment**

- 1601 remote control (functions)
- 1602 emergency stop (function)
- 1603 switch for outrigger function
- 1604 switch for boom function
- 1605 wiring harness
- 1606 central lubrication

**1700 sticker sets**

- 1701 safety hints
- 1702 description
- 1703 operating
- 1704 short operating instruction
- 1705 sticker „don't use the boom as crane"
- 1706 sticker „guideline operating with boom- and concrete pump"
- 1707 name plate
- 1708 sticker „danger high voltage"

**Competent inspector:**

Date: \_\_\_\_\_

Name: \_\_\_\_\_

Signature: \_\_\_\_\_  
(stamp)

**Customer:**

Signature: \_\_\_\_\_  
(stamp)

# Inspection report for concrete pump

Inspection report Nr:	Machine-Nr:	Hours of operation:
		Concrete output m³:
Company:	Post code:	City:

NL	WV
----	----

**Proof – Result of the tests**

without defects	defects	reinspection required	shut down
<input type="checkbox"/>	<input type="checkbox"/>	<input type="checkbox"/>	<input type="checkbox"/>

Reinspection until date: .....

**Error code:**

- |                  |                     |                   |                          |
|------------------|---------------------|-------------------|--------------------------|
| 00 no objections | 08 corrosion        | 16 porous         | 24 deformation           |
| 01 cracks        | 09 lacquer failures | 17 burned through | 25 bear movement         |
| 02 broken        | 10 fraying          | 18 not fixed      | 26 lubrication           |
| 03 leaky         | 11 scratched        | 19 clomp          | 27 readability           |
| 04 no fuction    | 12 bendet           | 20 sawing         | 28 missing components    |
| 05 low livetime  | 13 noises           | 21 contaminated   | 29 hydraulic             |
| 06 worn out      | 14 vibration        | 22 bad contact    | 30 electrical            |
| 07 dirt          | 15 miscellaneous    | 23 temperature    | 31 reinspection required |

**2000 documents**

2001 operating manual

2002 spare parts list

**2100 drive assembly**

2101 coupling and flange

2200 gear box

2300 hydraulic pump (main)

2400 oil-tank

2500 drive shaft

**2700 hydraulic control system**

2701 pressure relief valve

2702 pressure setting

2703 hydraulic line

2704 mechanical operation by hand

2800 oil –cooler

2900 accumulator

2901 proofs of the required tests according to accumulator regulation

2902 pressure gauge

Notes:



## Inspection report for concrete pump

Page 2-3

Inspection report Nr: \_\_\_\_\_ Machine-Nr: \_\_\_\_\_

**Error code:**

- |                  |                     |                   |                          |
|------------------|---------------------|-------------------|--------------------------|
| 00 no objections | 08 corrosion        | 16 porous         | 24 deformation           |
| 01 cracks        | 09 lacquer failures | 17 burned through | 25 bear movement         |
| 02 broken        | 10 fraying          | 18 not fixed      | 26 lubrication           |
| 03 leaky         | 11 scratched        | 19 clemp          | 27 readability           |
| 04 no function   | 12 bendet           | 20 sawing         | 28 missing components    |
| 05 low lifetime  | 13 noises           | 21 contamitated   | 29 hydraulical           |
| 06 worn out      | 14 vibration        | 22 bad contact    | 30 electrical            |
| 07 dirt          | 15 miscellaneous    | 23 temperature    | 31 reinspection required |

- |                                 |  |
|---------------------------------|--|
| <b>3000 central lubrication</b> | <input type="checkbox"/> <input type="checkbox"/> <input type="checkbox"/> <input type="checkbox"/> <input type="checkbox"/> |
| <b>3100 hydraulic motor</b>     | <input type="checkbox"/> <input type="checkbox"/> <input type="checkbox"/> <input type="checkbox"/> <input type="checkbox"/> |
| <b>3200 hydraulic lines</b>     | <input type="checkbox"/> <input type="checkbox"/> <input type="checkbox"/> <input type="checkbox"/> <input type="checkbox"/> |
| <b>3300 air compressor</b>      | <input type="checkbox"/> <input type="checkbox"/> <input type="checkbox"/> <input type="checkbox"/> <input type="checkbox"/> |
| <b>3400 control panel</b>       | <input type="checkbox"/> <input type="checkbox"/> <input type="checkbox"/> <input type="checkbox"/> <input type="checkbox"/> |
| <b>3500 concrete pump</b>       | <input type="checkbox"/> <input type="checkbox"/> <input type="checkbox"/> <input type="checkbox"/> <input type="checkbox"/> |
| <b>3700 S-valve</b>             | <input type="checkbox"/> <input type="checkbox"/> <input type="checkbox"/> <input type="checkbox"/> <input type="checkbox"/> |
| <b>3800 hopper</b>              | <input type="checkbox"/> <input type="checkbox"/> <input type="checkbox"/> <input type="checkbox"/> <input type="checkbox"/> |
| <b>4100 sub frame</b>           | <input type="checkbox"/> <input type="checkbox"/> <input type="checkbox"/> <input type="checkbox"/> <input type="checkbox"/> |
| <b>4200 water tank</b>          | <input type="checkbox"/> <input type="checkbox"/> <input type="checkbox"/> <input type="checkbox"/> <input type="checkbox"/> |
| <b>4300 axle</b>                | <input type="checkbox"/> <input type="checkbox"/> <input type="checkbox"/> <input type="checkbox"/> <input type="checkbox"/> |
| <b>4400 water pump</b>          | <input type="checkbox"/> <input type="checkbox"/> <input type="checkbox"/> <input type="checkbox"/> <input type="checkbox"/> |
| <b>4500 vibrator</b>            | <input type="checkbox"/> <input type="checkbox"/> <input type="checkbox"/> <input type="checkbox"/> <input type="checkbox"/> |

**4600 safety guards, equipment**

- |  |  |
|--|--|
| 4601 stair                                       | <input type="checkbox"/> <input type="checkbox"/> <input type="checkbox"/> <input type="checkbox"/> <input type="checkbox"/> |
| 4602 safety for stair                            | <input type="checkbox"/> <input type="checkbox"/> <input type="checkbox"/> <input type="checkbox"/> <input type="checkbox"/> |
| 4603 handrail                                    | <input type="checkbox"/> <input type="checkbox"/> <input type="checkbox"/> <input type="checkbox"/> <input type="checkbox"/> |
| 4604 hopper grid<br>(fixing device)              | <input type="checkbox"/> <input type="checkbox"/> <input type="checkbox"/> <input type="checkbox"/> <input type="checkbox"/> |
| 4606 distance of grid rods                       | <input type="checkbox"/> <input type="checkbox"/> <input type="checkbox"/> <input type="checkbox"/> <input type="checkbox"/> |
| 4607 distance from grid to<br>agitator           | <input type="checkbox"/> <input type="checkbox"/> <input type="checkbox"/> <input type="checkbox"/> <input type="checkbox"/> |
| 4609 agitator have to stop<br>if grid is open    | <input type="checkbox"/> <input type="checkbox"/> <input type="checkbox"/> <input type="checkbox"/> <input type="checkbox"/> |
| 4610 accumulator have to<br>dump if grid is open | <input type="checkbox"/> <input type="checkbox"/> <input type="checkbox"/> <input type="checkbox"/> <input type="checkbox"/> |
| 4612 cleaning flap hopper                        | <input type="checkbox"/> <input type="checkbox"/> <input type="checkbox"/> <input type="checkbox"/> <input type="checkbox"/> |
| 4613 safety grid into water<br>box               | <input type="checkbox"/> <input type="checkbox"/> <input type="checkbox"/> <input type="checkbox"/> <input type="checkbox"/> |

Notes:

# Inspection report for concrete pump

Inspection report Nr: \_\_\_\_\_

Machine-Nr: \_\_\_\_\_

**Error code:**

00 no objections	08 corrosion	16 porous	24 deformation
01 cracks	09 lacquer failures	17 burned through	25 bear movement
02 broken	10 fraying	18 not fixed	26 lubrication
03 leaky	11 scratched	19 clomp	27 readability
04 no function	12 bendet	20 sawing	28 missing components
05 low lifetime	13 noises	21 contamitated	29 hydraulical
06 worn out	14 vibration	22 bad contact	30 electrical
07 dirt	15 miscellaneous	23 temperature	31 reinspection required

4614 cover for rotating wave

4616 cover for chains

4617 cover for shift cylinder

4618 cover for moving parts

4619 cover for the exhaust pipe

**4700 electrical system**

4701 function of actuator component

4702 emergency stop function

4703 ground connections

4704 cables and wiring harness

4705 temperature switch

**4800 outrigger - system**

4801 transportation lock

4802 locking device

4803 backing plate

4804 jack cylinder connections

4805 pressure adjustment of jack cylinder

**4900 miscellaneous**

4901 additional assembled part from operator

4902 changes through operator

**Competent inspector:**

Date: .....

Name: .....

Signature: .....  
(stamp)

**Customer:**

Signature: .....  
(stamp)

**This test report is filed into the test book**

# Inspection report for concrete booms

Inspection report -Nr:	Machine-Nr:	Hours of operation:
		Concrete output m³:
Company:	Post code:	City:
Boom Type:	Boom Nr.:	NL <span style="margin-left: 100px;">WV</span>

**Proof – Result of the Tests**

without defects	defects	reinspection required	shut down
<input type="checkbox"/>	<input type="checkbox"/>	<input type="checkbox"/>	<input type="checkbox"/>

Reinspection until date: .....

**Error code:**

- |                  |                     |                   |                          |
|------------------|---------------------|-------------------|--------------------------|
| 00 no objections | 08 corrosion        | 16 porous         | 24 deformation           |
| 01 cracks        | 09 lacquer failures | 17 burned through | 25 bear movement         |
| 02 broken        | 10 fraying          | 18 not fixed      | 26 lubrication           |
| 03 leaky         | 11 scratched        | 19 clomp          | 27 readability           |
| 04 no function   | 12 bendet           | 20 sawing         | 28 missing components    |
| 05 low lifetime  | 13 noises           | 21 contaminated   | 29 hydraulic             |
| 06 worn out      | 14 vibration        | 22 bad contact    | 30 electrical            |
| 07 dirt          | 15 miscellaneous    | 23 temperature    | 31 reinspection required |

<p><b>100 documents</b></p> <p>101 instruction manual <input type="checkbox"/> <input type="checkbox"/> <input type="checkbox"/> <input type="checkbox"/> <input type="checkbox"/></p> <p>102 spare parts list <input type="checkbox"/> <input type="checkbox"/> <input type="checkbox"/> <input type="checkbox"/> <input type="checkbox"/></p> <p><b>200 sub frame</b></p> <p>201 frame connection cpl. <input type="checkbox"/> <input type="checkbox"/> <input type="checkbox"/> <input type="checkbox"/> <input type="checkbox"/></p> <p><b>300 outrigger front R+L</b></p> <p>301 transportation safety device <input type="checkbox"/> <input type="checkbox"/> <input type="checkbox"/> <input type="checkbox"/> <input type="checkbox"/></p> <p>302 outrigger <input type="checkbox"/> <input type="checkbox"/> <input type="checkbox"/> <input type="checkbox"/> <input type="checkbox"/></p> <p>303 extension box <input type="checkbox"/> <input type="checkbox"/> <input type="checkbox"/> <input type="checkbox"/> <input type="checkbox"/></p> <p>304 locking device <input type="checkbox"/> <input type="checkbox"/> <input type="checkbox"/> <input type="checkbox"/> <input type="checkbox"/></p> <p>305 slewing bearing <input type="checkbox"/> <input type="checkbox"/> <input type="checkbox"/> <input type="checkbox"/> <input type="checkbox"/></p> <p>306 turn locking device <input type="checkbox"/> <input type="checkbox"/> <input type="checkbox"/> <input type="checkbox"/> <input type="checkbox"/></p> <p>307 support safeguard <input type="checkbox"/> <input type="checkbox"/> <input type="checkbox"/> <input type="checkbox"/> <input type="checkbox"/></p> <p>308 support plate <input type="checkbox"/> <input type="checkbox"/> <input type="checkbox"/> <input type="checkbox"/> <input type="checkbox"/></p> <p>309 fixing of jack cylinder <input type="checkbox"/> <input type="checkbox"/> <input type="checkbox"/> <input type="checkbox"/> <input type="checkbox"/></p> <p>310 jack cylinder <input type="checkbox"/> <input type="checkbox"/> <input type="checkbox"/> <input type="checkbox"/> <input type="checkbox"/></p>	<p>311 swing cylinder <input type="checkbox"/> <input type="checkbox"/> <input type="checkbox"/> <input type="checkbox"/> <input type="checkbox"/></p> <p>312 telescopic-cylinder <input type="checkbox"/> <input type="checkbox"/> <input type="checkbox"/> <input type="checkbox"/> <input type="checkbox"/></p> <p>313 pressure adjustment <input type="checkbox"/> <input type="checkbox"/> <input type="checkbox"/> <input type="checkbox"/> <input type="checkbox"/></p> <p><b>400 outrigger rear L+R</b></p> <p>401 transportation safety device <input type="checkbox"/> <input type="checkbox"/> <input type="checkbox"/> <input type="checkbox"/> <input type="checkbox"/></p> <p>402 outrigger <input type="checkbox"/> <input type="checkbox"/> <input type="checkbox"/> <input type="checkbox"/> <input type="checkbox"/></p> <p>403 extension box <input type="checkbox"/> <input type="checkbox"/> <input type="checkbox"/> <input type="checkbox"/> <input type="checkbox"/></p> <p>405 locking device <input type="checkbox"/> <input type="checkbox"/> <input type="checkbox"/> <input type="checkbox"/> <input type="checkbox"/></p> <p>Notes:</p> <hr/> <hr/> <hr/> <hr/> <hr/>
---	---

# Inspection report for concrete booms

Inspection report Nr: \_\_\_\_\_ Boom type: \_\_\_\_\_ Machine-Nr: \_\_\_\_\_

- Error code:**
- |                  |                     |                   |                          |
|------------------|---------------------|-------------------|--------------------------|
| 00 no objections | 08 corrosion        | 16 porous         | 24 deformation           |
| 01 cracks        | 09 lacquer failures | 17 burned through | 25 bear movement         |
| 02 broken        | 10 fraying          | 18 not fixed      | 26 lubrication           |
| 03 leaky         | 11 scratched        | 19 clemp          | 27 readability           |
| 04 no function   | 12 bendet           | 20 sawing         | 28 missing components    |
| 05 low lifetime  | 13 noises           | 21 contaminated   | 29 hydraulical           |
| 06 worn out      | 14 vibration        | 22 bad contact    | 30 electrical            |
| 07 dirt          | 15 miscellaneous    | 23 temperature    | 31 reinspection required |

<p>406 slewing bearing <input type="checkbox"/> <input type="checkbox"/> <input type="checkbox"/> <input type="checkbox"/> <input type="checkbox"/></p> <p>407 turn locking device <input type="checkbox"/> <input type="checkbox"/> <input type="checkbox"/> <input type="checkbox"/> <input type="checkbox"/></p> <p>408 support safeguard <input type="checkbox"/> <input type="checkbox"/> <input type="checkbox"/> <input type="checkbox"/> <input type="checkbox"/></p> <p>409 support plate <input type="checkbox"/> <input type="checkbox"/> <input type="checkbox"/> <input type="checkbox"/> <input type="checkbox"/></p> <p>410 fixing of jack cylinder <input type="checkbox"/> <input type="checkbox"/> <input type="checkbox"/> <input type="checkbox"/> <input type="checkbox"/></p> <p>411 jack cylinder <input type="checkbox"/> <input type="checkbox"/> <input type="checkbox"/> <input type="checkbox"/> <input type="checkbox"/></p> <p>412 swing cylinder <input type="checkbox"/> <input type="checkbox"/> <input type="checkbox"/> <input type="checkbox"/> <input type="checkbox"/></p> <p>413 telescopic cylinder <input type="checkbox"/> <input type="checkbox"/> <input type="checkbox"/> <input type="checkbox"/> <input type="checkbox"/></p> <p><b>500 pedestal</b></p> <p>501 pedestal mounting <input type="checkbox"/> <input type="checkbox"/> <input type="checkbox"/> <input type="checkbox"/> <input type="checkbox"/></p> <p>502 sub frame <input type="checkbox"/> <input type="checkbox"/> <input type="checkbox"/> <input type="checkbox"/> <input type="checkbox"/></p> <p>503 truck frame <input type="checkbox"/> <input type="checkbox"/> <input type="checkbox"/> <input type="checkbox"/> <input type="checkbox"/></p> <p>504 pedestal (structure) <input type="checkbox"/> <input type="checkbox"/> <input type="checkbox"/> <input type="checkbox"/> <input type="checkbox"/></p> <p>505 boom valve without leaking <input type="checkbox"/> <input type="checkbox"/> <input type="checkbox"/> <input type="checkbox"/> <input type="checkbox"/></p> <p>506 boom rest <input type="checkbox"/> <input type="checkbox"/> <input type="checkbox"/> <input type="checkbox"/> <input type="checkbox"/></p> <p>507 transportation safety device <input type="checkbox"/> <input type="checkbox"/> <input type="checkbox"/> <input type="checkbox"/> <input type="checkbox"/></p> <p>508 hydraulic line <input type="checkbox"/> <input type="checkbox"/> <input type="checkbox"/> <input type="checkbox"/> <input type="checkbox"/></p> <p><b>600 slewing head with ball pivot</b></p> <p>601 slewing head <input type="checkbox"/> <input type="checkbox"/> <input type="checkbox"/> <input type="checkbox"/> <input type="checkbox"/></p> <p>602 ball pivot ring <input type="checkbox"/> <input type="checkbox"/> <input type="checkbox"/> <input type="checkbox"/> <input type="checkbox"/></p> <p>603 mounting ball pivot ring <input type="checkbox"/> <input type="checkbox"/> <input type="checkbox"/> <input type="checkbox"/> <input type="checkbox"/></p> <p>604 drive pinion <input type="checkbox"/> <input type="checkbox"/> <input type="checkbox"/> <input type="checkbox"/> <input type="checkbox"/></p>	<p>605 slewing drive mounting <input type="checkbox"/> <input type="checkbox"/> <input type="checkbox"/> <input type="checkbox"/> <input type="checkbox"/></p> <p>606 slewing stop device <input type="checkbox"/> <input type="checkbox"/> <input type="checkbox"/> <input type="checkbox"/> <input type="checkbox"/></p> <p>607 slewing drive (tooth backlash) <input type="checkbox"/> <input type="checkbox"/> <input type="checkbox"/> <input type="checkbox"/> <input type="checkbox"/></p> <p>608 slewing drive <input type="checkbox"/> <input type="checkbox"/> <input type="checkbox"/> <input type="checkbox"/> <input type="checkbox"/></p> <p>609 brake function <input type="checkbox"/> <input type="checkbox"/> <input type="checkbox"/> <input type="checkbox"/> <input type="checkbox"/></p> <p>610 speed <input type="checkbox"/> <input type="checkbox"/> <input type="checkbox"/> <input type="checkbox"/> <input type="checkbox"/></p> <p>611 pressure setting <input type="checkbox"/> <input type="checkbox"/> <input type="checkbox"/> <input type="checkbox"/> <input type="checkbox"/></p> <p>612 hydraulic lines <input type="checkbox"/> <input type="checkbox"/> <input type="checkbox"/> <input type="checkbox"/> <input type="checkbox"/></p> <p><b>700 slewing head with slewing column</b></p> <p>701 slewing head <input type="checkbox"/> <input type="checkbox"/> <input type="checkbox"/> <input type="checkbox"/> <input type="checkbox"/></p> <p>702 slewing column bearing <input type="checkbox"/> <input type="checkbox"/> <input type="checkbox"/> <input type="checkbox"/> <input type="checkbox"/></p> <p>703 slewing drive (tooth backlash) <input type="checkbox"/> <input type="checkbox"/> <input type="checkbox"/> <input type="checkbox"/> <input type="checkbox"/></p> <p>704 speed <input type="checkbox"/> <input type="checkbox"/> <input type="checkbox"/> <input type="checkbox"/> <input type="checkbox"/></p> <p>705 pressure settings <input type="checkbox"/> <input type="checkbox"/> <input type="checkbox"/> <input type="checkbox"/> <input type="checkbox"/></p> <p>706 hydraulic lines <input type="checkbox"/> <input type="checkbox"/> <input type="checkbox"/> <input type="checkbox"/> <input type="checkbox"/></p> <p>707 swivel cylinder <input type="checkbox"/> <input type="checkbox"/> <input type="checkbox"/> <input type="checkbox"/> <input type="checkbox"/></p> <p>Notes:</p> <hr/> <hr/> <hr/> <hr/>
---	---

# Inspection report for concrete booms

Inspection report Nr: \_\_\_\_\_ Boom type: \_\_\_\_\_ Machine-Nr: \_\_\_\_\_

Error code:			
00 no objections	08 corrosion	16 porous	24 deformation
01 cracks	09 lacquer failures	17 burned through	25 bear movement
02 broken	10 fraying	18 not fixed	26 lubrication
03 leaky	11 scratched	19 clomp	27 readability
04 no function	12 bendet	20 sawing	28 missing components
05 low lifetime	13 noises	21 contaminated	29 hydraulical
06 worn out	14 vibration	22 bad contact	30 electrical
07 dirt	15 miscellaneous	23 temperature	31 reinspection required

<p><b>800 boom</b>                    <input type="checkbox"/> <input type="checkbox"/> <input type="checkbox"/> <input type="checkbox"/> <input type="checkbox"/></p> <p>801 „Arm 1“</p> <p>802 bracket conveying line <input type="checkbox"/> <input type="checkbox"/> <input type="checkbox"/> <input type="checkbox"/> <input type="checkbox"/></p> <p>803 Drop hook                <input type="checkbox"/> <input type="checkbox"/> <input type="checkbox"/> <input type="checkbox"/> <input type="checkbox"/></p> <p>804 „Arm 2“                    <input type="checkbox"/> <input type="checkbox"/> <input type="checkbox"/> <input type="checkbox"/> <input type="checkbox"/></p> <p>805 bracket conveying line <input type="checkbox"/> <input type="checkbox"/> <input type="checkbox"/> <input type="checkbox"/> <input type="checkbox"/></p> <p>806 Drop hook                <input type="checkbox"/> <input type="checkbox"/> <input type="checkbox"/> <input type="checkbox"/> <input type="checkbox"/></p> <p>807 „Arm 3“                    <input type="checkbox"/> <input type="checkbox"/> <input type="checkbox"/> <input type="checkbox"/> <input type="checkbox"/></p> <p>808 bracket conveying line <input type="checkbox"/> <input type="checkbox"/> <input type="checkbox"/> <input type="checkbox"/> <input type="checkbox"/></p> <p>809 guidance and interlock of the arm                    <input type="checkbox"/> <input type="checkbox"/> <input type="checkbox"/> <input type="checkbox"/> <input type="checkbox"/></p> <p>810 „Arm 4“                    <input type="checkbox"/> <input type="checkbox"/> <input type="checkbox"/> <input type="checkbox"/> <input type="checkbox"/></p> <p>811 bracket conveying line <input type="checkbox"/> <input type="checkbox"/> <input type="checkbox"/> <input type="checkbox"/> <input type="checkbox"/></p> <p>812 guidance and interlock of the arm                    <input type="checkbox"/> <input type="checkbox"/> <input type="checkbox"/> <input type="checkbox"/> <input type="checkbox"/></p> <p>813 „Arm 5“                    <input type="checkbox"/> <input type="checkbox"/> <input type="checkbox"/> <input type="checkbox"/> <input type="checkbox"/></p> <p>814 bracket conveying line <input type="checkbox"/> <input type="checkbox"/> <input type="checkbox"/> <input type="checkbox"/> <input type="checkbox"/></p> <p>815 guidance and interlock of the arm                    <input type="checkbox"/> <input type="checkbox"/> <input type="checkbox"/> <input type="checkbox"/> <input type="checkbox"/></p> <p><b>900 joint „A“</b>                <input type="checkbox"/> <input type="checkbox"/> <input type="checkbox"/> <input type="checkbox"/> <input type="checkbox"/></p> <p>901 boom                        <input type="checkbox"/> <input type="checkbox"/> <input type="checkbox"/> <input type="checkbox"/> <input type="checkbox"/></p> <p>902 link lever                 <input type="checkbox"/> <input type="checkbox"/> <input type="checkbox"/> <input type="checkbox"/> <input type="checkbox"/></p> <p>903 forcing rod                <input type="checkbox"/> <input type="checkbox"/> <input type="checkbox"/> <input type="checkbox"/> <input type="checkbox"/></p> <p>904 pin                         <input type="checkbox"/> <input type="checkbox"/> <input type="checkbox"/> <input type="checkbox"/> <input type="checkbox"/></p> <p>905 cylinder                  <input type="checkbox"/> <input type="checkbox"/> <input type="checkbox"/> <input type="checkbox"/> <input type="checkbox"/></p>	<p>906 boom speed              <input type="checkbox"/> <input type="checkbox"/> <input type="checkbox"/> <input type="checkbox"/> <input type="checkbox"/></p> <p>907 pressure settings        <input type="checkbox"/> <input type="checkbox"/> <input type="checkbox"/> <input type="checkbox"/> <input type="checkbox"/></p> <p>908 hydraulic lines         <input type="checkbox"/> <input type="checkbox"/> <input type="checkbox"/> <input type="checkbox"/> <input type="checkbox"/></p> <p>909 load holding valve (piston side)                <input type="checkbox"/> <input type="checkbox"/> <input type="checkbox"/> <input type="checkbox"/> <input type="checkbox"/></p> <p>910 load holding valve (rod side)                    <input type="checkbox"/> <input type="checkbox"/> <input type="checkbox"/> <input type="checkbox"/> <input type="checkbox"/></p> <p><b>1000 joint „B“</b></p> <p>1001 boom                     <input type="checkbox"/> <input type="checkbox"/> <input type="checkbox"/> <input type="checkbox"/> <input type="checkbox"/></p> <p>1002 link lever                <input type="checkbox"/> <input type="checkbox"/> <input type="checkbox"/> <input type="checkbox"/> <input type="checkbox"/></p> <p>1003 forcing rod              <input type="checkbox"/> <input type="checkbox"/> <input type="checkbox"/> <input type="checkbox"/> <input type="checkbox"/></p> <p>1004 pin                        <input type="checkbox"/> <input type="checkbox"/> <input type="checkbox"/> <input type="checkbox"/> <input type="checkbox"/></p> <p>1005 cylinder                 <input type="checkbox"/> <input type="checkbox"/> <input type="checkbox"/> <input type="checkbox"/> <input type="checkbox"/></p> <p>1006 boom speed              <input type="checkbox"/> <input type="checkbox"/> <input type="checkbox"/> <input type="checkbox"/> <input type="checkbox"/></p> <p>1007 pressure settings        <input type="checkbox"/> <input type="checkbox"/> <input type="checkbox"/> <input type="checkbox"/> <input type="checkbox"/></p> <p>1008 hydraulic lines         <input type="checkbox"/> <input type="checkbox"/> <input type="checkbox"/> <input type="checkbox"/> <input type="checkbox"/></p> <p>1009 load holding valve (piston side)                <input type="checkbox"/> <input type="checkbox"/> <input type="checkbox"/> <input type="checkbox"/> <input type="checkbox"/></p> <p>1010 load holding valve (rod side)                    <input type="checkbox"/> <input type="checkbox"/> <input type="checkbox"/> <input type="checkbox"/> <input type="checkbox"/></p> <p>Notes:</p> <hr/> <hr/> <hr/> <hr/>
---	--

# Inspection report for concrete booms

Inspection report Nr: \_\_\_\_\_ Boom type: \_\_\_\_\_ Machine-Nr: \_\_\_\_\_

- |                  |                     |                   |                          |
|------------------|---------------------|-------------------|--------------------------|
| Error code:      |                     |                   |                          |
| 00 no objections | 08 corrosion        | 16 porous         | 24 deformation           |
| 01 cracks        | 09 lacquer failures | 17 burned through | 25 bear movement         |
| 02 broken        | 10 fraying          | 18 not fixed      | 26 lubrication           |
| 03 leaky         | 11 scratched        | 19 clemp          | 27 readability           |
| 04 no function   | 12 bendet           | 20 sawing         | 28 missing components    |
| 05 low lifetime  | 13 noises           | 21 contaminated   | 29 hydraulical           |
| 06 worn out      | 14 vibration        | 22 bad contact    | 30 electrical            |
| 07 dirt          | 15 miscellaneous    | 23 temperature    | 31 reinspection required |

**1100 joint "C"**

1101 boom	<input type="checkbox"/>	<input type="checkbox"/>	<input type="checkbox"/>	<input type="checkbox"/>	<input type="checkbox"/>
1102 link lever	<input type="checkbox"/>	<input type="checkbox"/>	<input type="checkbox"/>	<input type="checkbox"/>	<input type="checkbox"/>
1103 forcing rod	<input type="checkbox"/>	<input type="checkbox"/>	<input type="checkbox"/>	<input type="checkbox"/>	<input type="checkbox"/>
1104 pin	<input type="checkbox"/>	<input type="checkbox"/>	<input type="checkbox"/>	<input type="checkbox"/>	<input type="checkbox"/>
1105 cylinder	<input type="checkbox"/>	<input type="checkbox"/>	<input type="checkbox"/>	<input type="checkbox"/>	<input type="checkbox"/>
1106 boom speed	<input type="checkbox"/>	<input type="checkbox"/>	<input type="checkbox"/>	<input type="checkbox"/>	<input type="checkbox"/>
1107 pressure settings	<input type="checkbox"/>	<input type="checkbox"/>	<input type="checkbox"/>	<input type="checkbox"/>	<input type="checkbox"/>
1108 hydraulic lines	<input type="checkbox"/>	<input type="checkbox"/>	<input type="checkbox"/>	<input type="checkbox"/>	<input type="checkbox"/>
1109 load holding valve (piston side)	<input type="checkbox"/>	<input type="checkbox"/>	<input type="checkbox"/>	<input type="checkbox"/>	<input type="checkbox"/>
1110 load holding valve (rod side)	<input type="checkbox"/>	<input type="checkbox"/>	<input type="checkbox"/>	<input type="checkbox"/>	<input type="checkbox"/>

**1200 joint "D"**

1201 boom	<input type="checkbox"/>	<input type="checkbox"/>	<input type="checkbox"/>	<input type="checkbox"/>	<input type="checkbox"/>
1202 link lever	<input type="checkbox"/>	<input type="checkbox"/>	<input type="checkbox"/>	<input type="checkbox"/>	<input type="checkbox"/>
1203 forcing rod	<input type="checkbox"/>	<input type="checkbox"/>	<input type="checkbox"/>	<input type="checkbox"/>	<input type="checkbox"/>
1204 pin	<input type="checkbox"/>	<input type="checkbox"/>	<input type="checkbox"/>	<input type="checkbox"/>	<input type="checkbox"/>
1205 cylinder	<input type="checkbox"/>	<input type="checkbox"/>	<input type="checkbox"/>	<input type="checkbox"/>	<input type="checkbox"/>
1206 boom speed	<input type="checkbox"/>	<input type="checkbox"/>	<input type="checkbox"/>	<input type="checkbox"/>	<input type="checkbox"/>
1207 pressure settings	<input type="checkbox"/>	<input type="checkbox"/>	<input type="checkbox"/>	<input type="checkbox"/>	<input type="checkbox"/>
1208 hydraulic lines	<input type="checkbox"/>	<input type="checkbox"/>	<input type="checkbox"/>	<input type="checkbox"/>	<input type="checkbox"/>
1209 load holding valve (piston side)	<input type="checkbox"/>	<input type="checkbox"/>	<input type="checkbox"/>	<input type="checkbox"/>	<input type="checkbox"/>
1210 load holding valve (rod side)	<input type="checkbox"/>	<input type="checkbox"/>	<input type="checkbox"/>	<input type="checkbox"/>	<input type="checkbox"/>

**1300 joint „E“**

1301 boom	<input type="checkbox"/>	<input type="checkbox"/>	<input type="checkbox"/>	<input type="checkbox"/>	<input type="checkbox"/>
1302 link lever	<input type="checkbox"/>	<input type="checkbox"/>	<input type="checkbox"/>	<input type="checkbox"/>	<input type="checkbox"/>
1303 forcing rod	<input type="checkbox"/>	<input type="checkbox"/>	<input type="checkbox"/>	<input type="checkbox"/>	<input type="checkbox"/>
1304 pin	<input type="checkbox"/>	<input type="checkbox"/>	<input type="checkbox"/>	<input type="checkbox"/>	<input type="checkbox"/>
1305 cylinder	<input type="checkbox"/>	<input type="checkbox"/>	<input type="checkbox"/>	<input type="checkbox"/>	<input type="checkbox"/>
1306 boom speed	<input type="checkbox"/>	<input type="checkbox"/>	<input type="checkbox"/>	<input type="checkbox"/>	<input type="checkbox"/>
1307 pressure settings	<input type="checkbox"/>	<input type="checkbox"/>	<input type="checkbox"/>	<input type="checkbox"/>	<input type="checkbox"/>
1308 hydraulic lines	<input type="checkbox"/>	<input type="checkbox"/>	<input type="checkbox"/>	<input type="checkbox"/>	<input type="checkbox"/>
1309 load holding valve (piston side)	<input type="checkbox"/>	<input type="checkbox"/>	<input type="checkbox"/>	<input type="checkbox"/>	<input type="checkbox"/>
1310 load holding valve (rod side)	<input type="checkbox"/>	<input type="checkbox"/>	<input type="checkbox"/>	<input type="checkbox"/>	<input type="checkbox"/>

**1400 concrete delivery line**

1401 assembly of delivery line DN	<input type="checkbox"/>	<input type="checkbox"/>	<input type="checkbox"/>	<input type="checkbox"/>	<input type="checkbox"/>
1402 end hose DN+lenght	<input type="checkbox"/>	<input type="checkbox"/>	<input type="checkbox"/>	<input type="checkbox"/>	<input type="checkbox"/>
1403 delivery line DN	<input type="checkbox"/>	<input type="checkbox"/>	<input type="checkbox"/>	<input type="checkbox"/>	<input type="checkbox"/>
1404 rotating joints of - delivery line	<input type="checkbox"/>	<input type="checkbox"/>	<input type="checkbox"/>	<input type="checkbox"/>	<input type="checkbox"/>
1405 locking pin of the coupling	<input type="checkbox"/>	<input type="checkbox"/>	<input type="checkbox"/>	<input type="checkbox"/>	<input type="checkbox"/>

Notes:

## Inspection report for concrete booms

Inspection report Nr: \_\_\_\_\_ Boom type: \_\_\_\_\_ Machine-Nr: \_\_\_\_\_

**Error code:**

00 no objections	08 corrosion	16 porous	24 deformation
01 cracks	09 lacquer failures	17 burned through	25 bear movement
02 broken	10 fraying	18 not fixed	26 lubrication
03 leaky	11 scratched	19 clemp	27 readability
04 no function	12 bendet	20 sawing	28 missing components
05 low lifetime	13 noises	21 contamitated	29 hydraulical
06 worn out	14 vibration	22 bad contact	30 electrical
07 dirt	15 miscellaneous	23 temperature	31 reinspection required

<p>1406 end hose safety device <input type="checkbox"/> <input type="checkbox"/> <input type="checkbox"/> <input type="checkbox"/> <input type="checkbox"/></p> <p>1407 reducer <input type="checkbox"/> <input type="checkbox"/> <input type="checkbox"/> <input type="checkbox"/> <input type="checkbox"/></p> <p>1408 gate elbow, elbow 6" <input type="checkbox"/> <input type="checkbox"/> <input type="checkbox"/> <input type="checkbox"/> <input type="checkbox"/></p> <p><b>1500 hydraulic system and hydraulic valves</b></p> <p>1501 Pressure relief valve <input type="checkbox"/> <input type="checkbox"/> <input type="checkbox"/> <input type="checkbox"/> <input type="checkbox"/></p> <p>1502 pressure settings <input type="checkbox"/> <input type="checkbox"/> <input type="checkbox"/> <input type="checkbox"/> <input type="checkbox"/></p> <p>1503 hydraulic lines <input type="checkbox"/> <input type="checkbox"/> <input type="checkbox"/> <input type="checkbox"/> <input type="checkbox"/></p> <p>1504 hand operating-(function) <input type="checkbox"/> <input type="checkbox"/> <input type="checkbox"/> <input type="checkbox"/> <input type="checkbox"/></p> <p>1505 boom control valve <input type="checkbox"/> <input type="checkbox"/> <input type="checkbox"/> <input type="checkbox"/> <input type="checkbox"/></p> <p>1506 hydraulic pump <input type="checkbox"/> <input type="checkbox"/> <input type="checkbox"/> <input type="checkbox"/> <input type="checkbox"/></p> <p><b>1600 electric equipment</b></p> <p>1601 remote control (functions) <input type="checkbox"/> <input type="checkbox"/> <input type="checkbox"/> <input type="checkbox"/> <input type="checkbox"/></p> <p>1602 emergency stop (function) <input type="checkbox"/> <input type="checkbox"/> <input type="checkbox"/> <input type="checkbox"/> <input type="checkbox"/></p> <p>1603 switch for outrigger function <input type="checkbox"/> <input type="checkbox"/> <input type="checkbox"/> <input type="checkbox"/> <input type="checkbox"/></p> <p>1604 switch for boom function <input type="checkbox"/> <input type="checkbox"/> <input type="checkbox"/> <input type="checkbox"/> <input type="checkbox"/></p> <p>1605 wiring harness <input type="checkbox"/> <input type="checkbox"/> <input type="checkbox"/> <input type="checkbox"/> <input type="checkbox"/></p> <p>1606 central lubrication <input type="checkbox"/> <input type="checkbox"/> <input type="checkbox"/> <input type="checkbox"/> <input type="checkbox"/></p>	<p><b>1700 sticker sets</b></p> <p>1701 safety hints <input type="checkbox"/> <input type="checkbox"/> <input type="checkbox"/> <input type="checkbox"/> <input type="checkbox"/></p> <p>1702 description <input type="checkbox"/> <input type="checkbox"/> <input type="checkbox"/> <input type="checkbox"/> <input type="checkbox"/></p> <p>1703 operating <input type="checkbox"/> <input type="checkbox"/> <input type="checkbox"/> <input type="checkbox"/> <input type="checkbox"/></p> <p>1704 short operating instruction <input type="checkbox"/> <input type="checkbox"/> <input type="checkbox"/> <input type="checkbox"/> <input type="checkbox"/></p> <p>1705 sticker „don't use the boom as crane" <input type="checkbox"/> <input type="checkbox"/> <input type="checkbox"/> <input type="checkbox"/> <input type="checkbox"/></p> <p>1706 sticker „guideline operating with boom- and concrete pump" <input type="checkbox"/> <input type="checkbox"/> <input type="checkbox"/> <input type="checkbox"/> <input type="checkbox"/></p> <p>1707 name plate <input type="checkbox"/> <input type="checkbox"/> <input type="checkbox"/> <input type="checkbox"/> <input type="checkbox"/></p> <p>1708 sticker „danger high voltage" <input type="checkbox"/> <input type="checkbox"/> <input type="checkbox"/> <input type="checkbox"/> <input type="checkbox"/></p> <p><b>Competent inspector:</b></p> <p>Date: _____</p> <p>Name: _____</p> <p>Signature: _____ (stamp)</p> <p><b>Customer:</b></p> <p>Signature: _____ (stamp)</p>
--	---

# Inspection report for concrete pump

Inspection report Nr:	Machine-Nr:	Hours of operation:
		Concrete output m <sup>3</sup> :
Company:	Post code:	City:

NL	WV
----	----

**Proof – Result of the tests**

without defects	defects	reinspection required	shut down
<input type="checkbox"/>	<input type="checkbox"/>	<input type="checkbox"/>	<input type="checkbox"/>

Reinspection until date: .....

**Error code:**

00 no objections	08 corrosion	16 porous	24 deformation
01 cracks	09 lacquer failures	17 burned through	25 bear movement
02 broken	10 fraying	18 not fixed	26 lubrication
03 leaky	11 scratched	19 clomp	27 readability
04 no fuction	12 bendet	20 sawing	28 missing components
05 low livetime	13 noises	21 contaminated	29 hydraulical
06 worn out	14 vibration	22 bad contact	30 electrical
07 dirt	15 miscellaneous	23 temperature	31 reinspection required

<p><b>2000 documents</b></p> <p>2001 operating manual    <input type="checkbox"/> <input type="checkbox"/> <input type="checkbox"/> <input type="checkbox"/> <input type="checkbox"/></p> <p>2002 spare parts list    <input type="checkbox"/> <input type="checkbox"/> <input type="checkbox"/> <input type="checkbox"/> <input type="checkbox"/></p> <p><b>2100 drive assembly</b></p> <p>2101 coupling and flange    <input type="checkbox"/> <input type="checkbox"/> <input type="checkbox"/> <input type="checkbox"/> <input type="checkbox"/></p> <p><b>2200 gear box</b>    <input type="checkbox"/> <input type="checkbox"/> <input type="checkbox"/> <input type="checkbox"/> <input type="checkbox"/></p> <p><b>2300 hydraulic pump (main)</b>    <input type="checkbox"/> <input type="checkbox"/> <input type="checkbox"/> <input type="checkbox"/> <input type="checkbox"/></p> <p><b>2400 oil-tank</b>    <input type="checkbox"/> <input type="checkbox"/> <input type="checkbox"/> <input type="checkbox"/> <input type="checkbox"/></p> <p><b>2500 drive shaft</b>    <input type="checkbox"/> <input type="checkbox"/> <input type="checkbox"/> <input type="checkbox"/> <input type="checkbox"/></p>	<p><b>2700 hydraulic control system</b></p> <p>2701 pressure relief valve    <input type="checkbox"/> <input type="checkbox"/> <input type="checkbox"/> <input type="checkbox"/> <input type="checkbox"/></p> <p>2702 pressure setting    <input type="checkbox"/> <input type="checkbox"/> <input type="checkbox"/> <input type="checkbox"/> <input type="checkbox"/></p> <p>2703 hydraulic line    <input type="checkbox"/> <input type="checkbox"/> <input type="checkbox"/> <input type="checkbox"/> <input type="checkbox"/></p> <p>2704 mechanical operation by hand    <input type="checkbox"/> <input type="checkbox"/> <input type="checkbox"/> <input type="checkbox"/> <input type="checkbox"/></p> <p><b>2800 oil –cooler</b>    <input type="checkbox"/> <input type="checkbox"/> <input type="checkbox"/> <input type="checkbox"/> <input type="checkbox"/></p> <p><b>2900 accumulator</b>    <input type="checkbox"/> <input type="checkbox"/> <input type="checkbox"/> <input type="checkbox"/> <input type="checkbox"/></p> <p>2901 proofs of the required tests according to accumulator regulation    <input type="checkbox"/> <input type="checkbox"/> <input type="checkbox"/> <input type="checkbox"/> <input type="checkbox"/></p> <p>2902 pressure gauge    <input type="checkbox"/> <input type="checkbox"/> <input type="checkbox"/> <input type="checkbox"/> <input type="checkbox"/></p> <p>Notes:</p> <hr/> <hr/> <hr/>
--	--



# Inspection report for concrete pump

Inspection report Nr:

Machine-Nr:

Error code:

- |                  |                     |                   |                          |
|------------------|---------------------|-------------------|--------------------------|
| 00 no objections | 08 corrosion        | 16 porous         | 24 deformation           |
| 01 cracks        | 09 lacquer failures | 17 burned through | 25 bear movement         |
| 02 broken        | 10 fraying          | 18 not fixed      | 26 lubrication           |
| 03 leaky         | 11 scratched        | 19 clomp          | 27 readability           |
| 04 no function   | 12 bendet           | 20 sawing         | 28 missing components    |
| 05 low lifetime  | 13 noises           | 21 contaminated   | 29 hydraulical           |
| 06 worn out      | 14 vibration        | 22 bad contact    | 30 electrical            |
| 07 dirt          | 15 miscellaneous    | 23 temperature    | 31 reinspection required |

- 3000 central lubrication
- 3100 hydraulic motor
- 3200 hydraulic lines
- 3300 air compressor
- 3400 control panel
- 3500 concrete pump
- 3700 S-valve
- 3800 hopper
- 4100 sub frame
- 4200 water tank
- 4300 axle
- 4400 water pump
- 4500 vibrator

- 4600 safety guards, equipment**
- 4601 stair
  - 4602 safety for stair
  - 4603 handrail
  - 4604 hopper grid (fixing device)
  - 4606 distance of grid rods
  - 4607 distance from grid to agitator
  - 4609 agitator have to stop if grid is open
  - 4610 accumulator have to dump if grid is open
  - 4612 cleaning flap hopper
  - 4613 safety grid into water box

Notes:

# Inspection report for concrete pump

Inspection report Nr: \_\_\_\_\_ Machine-Nr: \_\_\_\_\_

**Error code:**

00 no objections	08 corrosion	16 porous	24 deformation
01 cracks	09 lacquer failures	17 burned through	25 bear movement
02 broken	10 fraying	18 not fixed	26 lubrication
03 leaky	11 scratched	19 clemp	27 readability
04 no function	12 bendet	20 sawing	28 missing components
05 low lifetime	13 noises	21 contaminated	29 hydraulical
06 worn out	14 vibration	22 bad contact	30 electrical
07 dirt	15 miscellaneous	23 temperature	31 reinspection required

4614 cover for rotating wave

4616 cover for chains

4617 cover for shift cylinder

4618 cover for moving parts

4619 cover for the exhaust pipe

**4700 electrical system**

4701 function of actuator component

4702 emergency stop function

4703 ground connections

4704 cables and wiring harness

4705 temperature switch

**4800 outrigger - system**

4801 transportation lock

4802 locking device

4803 backing plate

4804 jack cylinder connections

4805 pressure adjustment of jack cylinder

**4900 miscellaneous**

4901 additional assembled part from operator

4902 changes through operator

**Competent inspector:**

Date: .....

Name: .....

Signature: .....  
(stamp)

**Customer:**

Signature: .....  
(stamp)

**This test report is filed into the test book**

# Inspection report for concrete booms

Inspection report -Nr:	Machine-Nr	Hours of operation:	
		Concrete output m <sup>3</sup> :	
Company:	Post code:	City:	
Boom Type:	Boom Nr.	NL	WV

**Proof – Result of the Tests**

without defects	defects	reinspection required	shut down
<input type="checkbox"/>	<input type="checkbox"/>	<input type="checkbox"/>	<input type="checkbox"/>

Reinspection until date: .....

**Error code:**

- |                  |                     |                   |                          |
|------------------|---------------------|-------------------|--------------------------|
| 00 no objections | 08 corrosion        | 16 porous         | 24 deformation           |
| 01 cracks        | 09 lacquer failures | 17 burned through | 25 bear movement         |
| 02 broken        | 10 fraying          | 18 not fixed      | 26 lubrication           |
| 03 leaky         | 11 scratched        | 19 clemp          | 27 readability           |
| 04 no function   | 12 bendet           | 20 sawing         | 28 missing components    |
| 05 low lifetime  | 13 noises           | 21 contaminated   | 29 hydraulical           |
| 06 worn out      | 14 vibration        | 22 bad contact    | 30 electrical            |
| 07 dirt          | 15 miscellaneous    | 23 temperature    | 31 reinspection required |

<p><b>100 documents</b></p> <p>101 instruction manual    <input type="checkbox"/> <input type="checkbox"/> <input type="checkbox"/> <input type="checkbox"/> <input type="checkbox"/></p> <p>102 spare parts list      <input type="checkbox"/> <input type="checkbox"/> <input type="checkbox"/> <input type="checkbox"/> <input type="checkbox"/></p> <p><b>200 sub frame</b></p> <p>201 frame connection cpl.   <input type="checkbox"/> <input type="checkbox"/> <input type="checkbox"/> <input type="checkbox"/> <input type="checkbox"/></p> <p><b>300 outrigger front R+L</b></p> <p>301 transportation safety device   <input type="checkbox"/> <input type="checkbox"/> <input type="checkbox"/> <input type="checkbox"/> <input type="checkbox"/></p> <p>302 outrigger                    <input type="checkbox"/> <input type="checkbox"/> <input type="checkbox"/> <input type="checkbox"/> <input type="checkbox"/></p> <p>303 extension box               <input type="checkbox"/> <input type="checkbox"/> <input type="checkbox"/> <input type="checkbox"/> <input type="checkbox"/></p> <p>304 locking device               <input type="checkbox"/> <input type="checkbox"/> <input type="checkbox"/> <input type="checkbox"/> <input type="checkbox"/></p> <p>305 slewing bearing             <input type="checkbox"/> <input type="checkbox"/> <input type="checkbox"/> <input type="checkbox"/> <input type="checkbox"/></p> <p>306 turn locking device         <input type="checkbox"/> <input type="checkbox"/> <input type="checkbox"/> <input type="checkbox"/> <input type="checkbox"/></p> <p>307 support safeguard         <input type="checkbox"/> <input type="checkbox"/> <input type="checkbox"/> <input type="checkbox"/> <input type="checkbox"/></p> <p>308 support plate                <input type="checkbox"/> <input type="checkbox"/> <input type="checkbox"/> <input type="checkbox"/> <input type="checkbox"/></p> <p>309 fixing of jack cylinder     <input type="checkbox"/> <input type="checkbox"/> <input type="checkbox"/> <input type="checkbox"/> <input type="checkbox"/></p> <p>310 jack cylinder                <input type="checkbox"/> <input type="checkbox"/> <input type="checkbox"/> <input type="checkbox"/> <input type="checkbox"/></p>	<p>311 swing cylinder               <input type="checkbox"/> <input type="checkbox"/> <input type="checkbox"/> <input type="checkbox"/> <input type="checkbox"/></p> <p>312 telescopic-cylinder         <input type="checkbox"/> <input type="checkbox"/> <input type="checkbox"/> <input type="checkbox"/> <input type="checkbox"/></p> <p>313 pressure adjustment       <input type="checkbox"/> <input type="checkbox"/> <input type="checkbox"/> <input type="checkbox"/> <input type="checkbox"/></p> <p><b>400 outrigger rear L+R</b></p> <p>401 transportation safety device   <input type="checkbox"/> <input type="checkbox"/> <input type="checkbox"/> <input type="checkbox"/> <input type="checkbox"/></p> <p>402 outrigger                     <input type="checkbox"/> <input type="checkbox"/> <input type="checkbox"/> <input type="checkbox"/> <input type="checkbox"/></p> <p>403 extension box                <input type="checkbox"/> <input type="checkbox"/> <input type="checkbox"/> <input type="checkbox"/> <input type="checkbox"/></p> <p>405 locking device                <input type="checkbox"/> <input type="checkbox"/> <input type="checkbox"/> <input type="checkbox"/> <input type="checkbox"/></p> <p><b>Notes:</b></p> <hr/> <hr/> <hr/> <hr/> <hr/>
--	--

# Inspection report for concrete booms

Inspection report Nr: \_\_\_\_\_ Boom type: \_\_\_\_\_ Machine-Nr: \_\_\_\_\_

**Error code:**

- |                  |                     |                   |                          |
|------------------|---------------------|-------------------|--------------------------|
| 00 no objections | 08 corrosion        | 16 porous         | 24 deformation           |
| 01 cracks        | 09 lacquer failures | 17 burned through | 25 bear movement         |
| 02 broken        | 10 fraying          | 18 not fixed      | 26 lubrication           |
| 03 leaky         | 11 scratched        | 19 clomp          | 27 readability           |
| 04 no function   | 12 bendet           | 20 sawing         | 28 missing components    |
| 05 low lifetime  | 13 noises           | 21 contaminated   | 29 hydraulic             |
| 06 worn out      | 14 vibration        | 22 bad contact    | 30 electrical            |
| 07 dirt          | 15 miscellaneous    | 23 temperature    | 31 reinspection required |

<p>406 slewing bearing <input type="checkbox"/> <input type="checkbox"/> <input type="checkbox"/> <input type="checkbox"/> <input type="checkbox"/></p> <p>407 turn locking device <input type="checkbox"/> <input type="checkbox"/> <input type="checkbox"/> <input type="checkbox"/> <input type="checkbox"/></p> <p>408 support safeguard <input type="checkbox"/> <input type="checkbox"/> <input type="checkbox"/> <input type="checkbox"/> <input type="checkbox"/></p> <p>409 support plate <input type="checkbox"/> <input type="checkbox"/> <input type="checkbox"/> <input type="checkbox"/> <input type="checkbox"/></p> <p>410 fixing of jack cylinder <input type="checkbox"/> <input type="checkbox"/> <input type="checkbox"/> <input type="checkbox"/> <input type="checkbox"/></p> <p>411 jack cylinder <input type="checkbox"/> <input type="checkbox"/> <input type="checkbox"/> <input type="checkbox"/> <input type="checkbox"/></p> <p>412 swing cylinder <input type="checkbox"/> <input type="checkbox"/> <input type="checkbox"/> <input type="checkbox"/> <input type="checkbox"/></p> <p>413 telescopic cylinder <input type="checkbox"/> <input type="checkbox"/> <input type="checkbox"/> <input type="checkbox"/> <input type="checkbox"/></p> <p><b>500 pedestal</b></p> <p>501 pedestal mounting <input type="checkbox"/> <input type="checkbox"/> <input type="checkbox"/> <input type="checkbox"/> <input type="checkbox"/></p> <p>502 sub frame <input type="checkbox"/> <input type="checkbox"/> <input type="checkbox"/> <input type="checkbox"/> <input type="checkbox"/></p> <p>503 truck frame <input type="checkbox"/> <input type="checkbox"/> <input type="checkbox"/> <input type="checkbox"/> <input type="checkbox"/></p> <p>504 pedestal (structure) <input type="checkbox"/> <input type="checkbox"/> <input type="checkbox"/> <input type="checkbox"/> <input type="checkbox"/></p> <p>505 boom valve without leaking <input type="checkbox"/> <input type="checkbox"/> <input type="checkbox"/> <input type="checkbox"/> <input type="checkbox"/></p> <p>506 boom rest <input type="checkbox"/> <input type="checkbox"/> <input type="checkbox"/> <input type="checkbox"/> <input type="checkbox"/></p> <p>507 transportation safety device <input type="checkbox"/> <input type="checkbox"/> <input type="checkbox"/> <input type="checkbox"/> <input type="checkbox"/></p> <p>508 hydraulic line <input type="checkbox"/> <input type="checkbox"/> <input type="checkbox"/> <input type="checkbox"/> <input type="checkbox"/></p> <p><b>600 slewing head with ball pivot</b></p> <p>601 slewing head <input type="checkbox"/> <input type="checkbox"/> <input type="checkbox"/> <input type="checkbox"/> <input type="checkbox"/></p> <p>602 ball pivot ring <input type="checkbox"/> <input type="checkbox"/> <input type="checkbox"/> <input type="checkbox"/> <input type="checkbox"/></p> <p>603 mounting ball pivot ring <input type="checkbox"/> <input type="checkbox"/> <input type="checkbox"/> <input type="checkbox"/> <input type="checkbox"/></p> <p>604 drive pinion <input type="checkbox"/> <input type="checkbox"/> <input type="checkbox"/> <input type="checkbox"/> <input type="checkbox"/></p>	<p>605 slewing drive mounting <input type="checkbox"/> <input type="checkbox"/> <input type="checkbox"/> <input type="checkbox"/> <input type="checkbox"/></p> <p>606 slewing stop device <input type="checkbox"/> <input type="checkbox"/> <input type="checkbox"/> <input type="checkbox"/> <input type="checkbox"/></p> <p>607 slewing drive (tooth backlash) <input type="checkbox"/> <input type="checkbox"/> <input type="checkbox"/> <input type="checkbox"/> <input type="checkbox"/></p> <p>608 slewing drive <input type="checkbox"/> <input type="checkbox"/> <input type="checkbox"/> <input type="checkbox"/> <input type="checkbox"/></p> <p>609 brake function <input type="checkbox"/> <input type="checkbox"/> <input type="checkbox"/> <input type="checkbox"/> <input type="checkbox"/></p> <p>610 speed <input type="checkbox"/> <input type="checkbox"/> <input type="checkbox"/> <input type="checkbox"/> <input type="checkbox"/></p> <p>611 pressure setting <input type="checkbox"/> <input type="checkbox"/> <input type="checkbox"/> <input type="checkbox"/> <input type="checkbox"/></p> <p>612 hydraulic lines <input type="checkbox"/> <input type="checkbox"/> <input type="checkbox"/> <input type="checkbox"/> <input type="checkbox"/></p> <p><b>700 slewing head with slewing column</b></p> <p>701 slewing head <input type="checkbox"/> <input type="checkbox"/> <input type="checkbox"/> <input type="checkbox"/> <input type="checkbox"/></p> <p>702 slewing column bearing <input type="checkbox"/> <input type="checkbox"/> <input type="checkbox"/> <input type="checkbox"/> <input type="checkbox"/></p> <p>703 slewing drive (tooth backlash) <input type="checkbox"/> <input type="checkbox"/> <input type="checkbox"/> <input type="checkbox"/> <input type="checkbox"/></p> <p>704 speed <input type="checkbox"/> <input type="checkbox"/> <input type="checkbox"/> <input type="checkbox"/> <input type="checkbox"/></p> <p>705 pressure settings <input type="checkbox"/> <input type="checkbox"/> <input type="checkbox"/> <input type="checkbox"/> <input type="checkbox"/></p> <p>706 hydraulic lines <input type="checkbox"/> <input type="checkbox"/> <input type="checkbox"/> <input type="checkbox"/> <input type="checkbox"/></p> <p>707 swivel cylinder <input type="checkbox"/> <input type="checkbox"/> <input type="checkbox"/> <input type="checkbox"/> <input type="checkbox"/></p> <p>Notes:</p> <hr/> <hr/> <hr/> <hr/>
---	---

# Inspection report for concrete booms

Inspection report Nr: \_\_\_\_\_ Boom type: \_\_\_\_\_ Machine-Nr: \_\_\_\_\_

**Error code:**

- |                  |                     |                   |                          |
|------------------|---------------------|-------------------|--------------------------|
| 00 no objections | 08 corrosion        | 16 porous         | 24 deformation           |
| 01 cracks        | 09 lacquer failures | 17 burned through | 25 bear movement         |
| 02 broken        | 10 fraying          | 18 not fixed      | 26 lubrication           |
| 03 leaky         | 11 scratched        | 19 clomp          | 27 readability           |
| 04 no function   | 12 bendet           | 20 sawing         | 28 missing components    |
| 05 low lifetime  | 13 noises           | 21 contaminated   | 29 hydraulical           |
| 06 worn out      | 14 vibration        | 22 bad contact    | 30 electrical            |
| 07 dirt          | 15 miscellaneous    | 23 temperature    | 31 reinspection required |

<p><b>800 boom</b> <input type="checkbox"/> <input type="checkbox"/> <input type="checkbox"/> <input type="checkbox"/> <input type="checkbox"/></p> <p>801 „Arm 1“ <input type="checkbox"/> <input type="checkbox"/> <input type="checkbox"/> <input type="checkbox"/> <input type="checkbox"/></p> <p>802 bracket conveying line <input type="checkbox"/> <input type="checkbox"/> <input type="checkbox"/> <input type="checkbox"/> <input type="checkbox"/></p> <p>803 Drop hook <input type="checkbox"/> <input type="checkbox"/> <input type="checkbox"/> <input type="checkbox"/> <input type="checkbox"/></p> <p>804 „Arm 2“ <input type="checkbox"/> <input type="checkbox"/> <input type="checkbox"/> <input type="checkbox"/> <input type="checkbox"/></p> <p>805 bracket conveying line <input type="checkbox"/> <input type="checkbox"/> <input type="checkbox"/> <input type="checkbox"/> <input type="checkbox"/></p> <p>806 Drop hook <input type="checkbox"/> <input type="checkbox"/> <input type="checkbox"/> <input type="checkbox"/> <input type="checkbox"/></p> <p>807 „Arm 3“ <input type="checkbox"/> <input type="checkbox"/> <input type="checkbox"/> <input type="checkbox"/> <input type="checkbox"/></p> <p>808 bracket conveying line <input type="checkbox"/> <input type="checkbox"/> <input type="checkbox"/> <input type="checkbox"/> <input type="checkbox"/></p> <p>809 guidance and interlock of the arm <input type="checkbox"/> <input type="checkbox"/> <input type="checkbox"/> <input type="checkbox"/> <input type="checkbox"/></p> <p>810 „Arm 4“ <input type="checkbox"/> <input type="checkbox"/> <input type="checkbox"/> <input type="checkbox"/> <input type="checkbox"/></p> <p>811 bracket conveying line <input type="checkbox"/> <input type="checkbox"/> <input type="checkbox"/> <input type="checkbox"/> <input type="checkbox"/></p> <p>812 guidance and interlock of the arm <input type="checkbox"/> <input type="checkbox"/> <input type="checkbox"/> <input type="checkbox"/> <input type="checkbox"/></p> <p>813 „Arm 5“ <input type="checkbox"/> <input type="checkbox"/> <input type="checkbox"/> <input type="checkbox"/> <input type="checkbox"/></p> <p>814 bracket conveying line <input type="checkbox"/> <input type="checkbox"/> <input type="checkbox"/> <input type="checkbox"/> <input type="checkbox"/></p> <p>815 guidance and interlock of the arm <input type="checkbox"/> <input type="checkbox"/> <input type="checkbox"/> <input type="checkbox"/> <input type="checkbox"/></p> <p><b>900 joint „A“</b> <input type="checkbox"/> <input type="checkbox"/> <input type="checkbox"/> <input type="checkbox"/> <input type="checkbox"/></p> <p>901 boom <input type="checkbox"/> <input type="checkbox"/> <input type="checkbox"/> <input type="checkbox"/> <input type="checkbox"/></p> <p>902 link lever <input type="checkbox"/> <input type="checkbox"/> <input type="checkbox"/> <input type="checkbox"/> <input type="checkbox"/></p> <p>903 forcing rod <input type="checkbox"/> <input type="checkbox"/> <input type="checkbox"/> <input type="checkbox"/> <input type="checkbox"/></p> <p>904 pin <input type="checkbox"/> <input type="checkbox"/> <input type="checkbox"/> <input type="checkbox"/> <input type="checkbox"/></p> <p>905 cylinder <input type="checkbox"/> <input type="checkbox"/> <input type="checkbox"/> <input type="checkbox"/> <input type="checkbox"/></p>	<p>906 boom speed <input type="checkbox"/> <input type="checkbox"/> <input type="checkbox"/> <input type="checkbox"/> <input type="checkbox"/></p> <p>907 pressure settings <input type="checkbox"/> <input type="checkbox"/> <input type="checkbox"/> <input type="checkbox"/> <input type="checkbox"/></p> <p>908 hydraulic lines <input type="checkbox"/> <input type="checkbox"/> <input type="checkbox"/> <input type="checkbox"/> <input type="checkbox"/></p> <p>909 load holding valve (piston side) <input type="checkbox"/> <input type="checkbox"/> <input type="checkbox"/> <input type="checkbox"/> <input type="checkbox"/></p> <p>910 load holding valve (rod side) <input type="checkbox"/> <input type="checkbox"/> <input type="checkbox"/> <input type="checkbox"/> <input type="checkbox"/></p> <p><b>1000 joint „B“</b></p> <p>1001 boom <input type="checkbox"/> <input type="checkbox"/> <input type="checkbox"/> <input type="checkbox"/> <input type="checkbox"/></p> <p>1002 link lever <input type="checkbox"/> <input type="checkbox"/> <input type="checkbox"/> <input type="checkbox"/> <input type="checkbox"/></p> <p>1003 forcing rod <input type="checkbox"/> <input type="checkbox"/> <input type="checkbox"/> <input type="checkbox"/> <input type="checkbox"/></p> <p>1004 pin <input type="checkbox"/> <input type="checkbox"/> <input type="checkbox"/> <input type="checkbox"/> <input type="checkbox"/></p> <p>1005 cylinder <input type="checkbox"/> <input type="checkbox"/> <input type="checkbox"/> <input type="checkbox"/> <input type="checkbox"/></p> <p>1006 boom speed <input type="checkbox"/> <input type="checkbox"/> <input type="checkbox"/> <input type="checkbox"/> <input type="checkbox"/></p> <p>1007 pressure settings <input type="checkbox"/> <input type="checkbox"/> <input type="checkbox"/> <input type="checkbox"/> <input type="checkbox"/></p> <p>1008 hydraulic lines <input type="checkbox"/> <input type="checkbox"/> <input type="checkbox"/> <input type="checkbox"/> <input type="checkbox"/></p> <p>1009 load holding valve (piston side) <input type="checkbox"/> <input type="checkbox"/> <input type="checkbox"/> <input type="checkbox"/> <input type="checkbox"/></p> <p>1010 load holding valve (rod side) <input type="checkbox"/> <input type="checkbox"/> <input type="checkbox"/> <input type="checkbox"/> <input type="checkbox"/></p> <p>Notes:</p> <hr/> <hr/> <hr/> <hr/>
--	---

# Inspection report for concrete booms

Inspection report Nr: \_\_\_\_\_ Boom type: \_\_\_\_\_ Machine-Nr: \_\_\_\_\_

- |                  |                     |                   |                          |
|------------------|---------------------|-------------------|--------------------------|
| Error code:      |                     |                   |                          |
| 00 no objections | 08 corrosion        | 16 porous         | 24 deformation           |
| 01 cracks        | 09 lacquer failures | 17 burned through | 25 bear movement         |
| 02 broken        | 10 fraying          | 18 not fixed      | 26 lubrication           |
| 03 leaky         | 11 scratched        | 19 clemp          | 27 readability           |
| 04 no function   | 12 bendet           | 20 sawing         | 28 missing components    |
| 05 low lifetime  | 13 noises           | 21 contaminated   | 29 hydraulical           |
| 06 worn out      | 14 vibration        | 22 bad contact    | 30 electrical            |
| 07 dirt          | 15 miscellaneous    | 23 temperature    | 31 reinspection required |

**1100 joint "C"**

- |  |                          |                          |                          |                          |                          |
|--|--------------------------|--------------------------|--------------------------|--------------------------|--------------------------|
| 1101 boom                                | <input type="checkbox"/> | <input type="checkbox"/> | <input type="checkbox"/> | <input type="checkbox"/> | <input type="checkbox"/> |
| 1102 link lever                          | <input type="checkbox"/> | <input type="checkbox"/> | <input type="checkbox"/> | <input type="checkbox"/> | <input type="checkbox"/> |
| 1103 forcing rod                         | <input type="checkbox"/> | <input type="checkbox"/> | <input type="checkbox"/> | <input type="checkbox"/> | <input type="checkbox"/> |
| 1104 pin                                 | <input type="checkbox"/> | <input type="checkbox"/> | <input type="checkbox"/> | <input type="checkbox"/> | <input type="checkbox"/> |
| 1105 cylinder                            | <input type="checkbox"/> | <input type="checkbox"/> | <input type="checkbox"/> | <input type="checkbox"/> | <input type="checkbox"/> |
| 1106 boom speed                          | <input type="checkbox"/> | <input type="checkbox"/> | <input type="checkbox"/> | <input type="checkbox"/> | <input type="checkbox"/> |
| 1107 pressure settings                   | <input type="checkbox"/> | <input type="checkbox"/> | <input type="checkbox"/> | <input type="checkbox"/> | <input type="checkbox"/> |
| 1108 hydraulic lines                     | <input type="checkbox"/> | <input type="checkbox"/> | <input type="checkbox"/> | <input type="checkbox"/> | <input type="checkbox"/> |
| 1109 load holding valve<br>(piston side) | <input type="checkbox"/> | <input type="checkbox"/> | <input type="checkbox"/> | <input type="checkbox"/> | <input type="checkbox"/> |
| 1110 load hokding valve<br>(rod side)    | <input type="checkbox"/> | <input type="checkbox"/> | <input type="checkbox"/> | <input type="checkbox"/> | <input type="checkbox"/> |

**1200 joint "D"**

- |  |                          |                          |                          |                          |                          |
|--|--------------------------|--------------------------|--------------------------|--------------------------|--------------------------|
| 1201 boom                                | <input type="checkbox"/> | <input type="checkbox"/> | <input type="checkbox"/> | <input type="checkbox"/> | <input type="checkbox"/> |
| 1202 link lever                          | <input type="checkbox"/> | <input type="checkbox"/> | <input type="checkbox"/> | <input type="checkbox"/> | <input type="checkbox"/> |
| 1203 forcing rod                         | <input type="checkbox"/> | <input type="checkbox"/> | <input type="checkbox"/> | <input type="checkbox"/> | <input type="checkbox"/> |
| 1204 pin                                 | <input type="checkbox"/> | <input type="checkbox"/> | <input type="checkbox"/> | <input type="checkbox"/> | <input type="checkbox"/> |
| 1205 cylinder                            | <input type="checkbox"/> | <input type="checkbox"/> | <input type="checkbox"/> | <input type="checkbox"/> | <input type="checkbox"/> |
| 1206 boom speed                          | <input type="checkbox"/> | <input type="checkbox"/> | <input type="checkbox"/> | <input type="checkbox"/> | <input type="checkbox"/> |
| 1207 pressure settings                   | <input type="checkbox"/> | <input type="checkbox"/> | <input type="checkbox"/> | <input type="checkbox"/> | <input type="checkbox"/> |
| 1208 hydraulic lines                     | <input type="checkbox"/> | <input type="checkbox"/> | <input type="checkbox"/> | <input type="checkbox"/> | <input type="checkbox"/> |
| 1209 load holding valve<br>(piston side) | <input type="checkbox"/> | <input type="checkbox"/> | <input type="checkbox"/> | <input type="checkbox"/> | <input type="checkbox"/> |
| 1210 load holding valve<br>(rod side)    | <input type="checkbox"/> | <input type="checkbox"/> | <input type="checkbox"/> | <input type="checkbox"/> | <input type="checkbox"/> |

**1300 joint „E“**

- |  |                          |                          |                          |                          |                          |
|--|--------------------------|--------------------------|--------------------------|--------------------------|--------------------------|
| 1301 boom                                | <input type="checkbox"/> | <input type="checkbox"/> | <input type="checkbox"/> | <input type="checkbox"/> | <input type="checkbox"/> |
| 1302 link lever                          | <input type="checkbox"/> | <input type="checkbox"/> | <input type="checkbox"/> | <input type="checkbox"/> | <input type="checkbox"/> |
| 1303 forcing rod                         | <input type="checkbox"/> | <input type="checkbox"/> | <input type="checkbox"/> | <input type="checkbox"/> | <input type="checkbox"/> |
| 1304 pin                                 | <input type="checkbox"/> | <input type="checkbox"/> | <input type="checkbox"/> | <input type="checkbox"/> | <input type="checkbox"/> |
| 1305 cylinder                            | <input type="checkbox"/> | <input type="checkbox"/> | <input type="checkbox"/> | <input type="checkbox"/> | <input type="checkbox"/> |
| 1306 boom speed                          | <input type="checkbox"/> | <input type="checkbox"/> | <input type="checkbox"/> | <input type="checkbox"/> | <input type="checkbox"/> |
| 1307 pressure settings                   | <input type="checkbox"/> | <input type="checkbox"/> | <input type="checkbox"/> | <input type="checkbox"/> | <input type="checkbox"/> |
| 1308 hydraulic lines                     | <input type="checkbox"/> | <input type="checkbox"/> | <input type="checkbox"/> | <input type="checkbox"/> | <input type="checkbox"/> |
| 1309 load holding valve<br>(piston side) | <input type="checkbox"/> | <input type="checkbox"/> | <input type="checkbox"/> | <input type="checkbox"/> | <input type="checkbox"/> |
| 1310 load holding valve<br>(rod side)    | <input type="checkbox"/> | <input type="checkbox"/> | <input type="checkbox"/> | <input type="checkbox"/> | <input type="checkbox"/> |

**1400 concrete delivery line**

- |  |                          |                          |                          |                          |                          |
|--|--------------------------|--------------------------|--------------------------|--------------------------|--------------------------|
| 1401 assembly of delivery<br>line DN       | <input type="checkbox"/> | <input type="checkbox"/> | <input type="checkbox"/> | <input type="checkbox"/> | <input type="checkbox"/> |
| 1402 end hose<br>DN+lenght                 | <input type="checkbox"/> | <input type="checkbox"/> | <input type="checkbox"/> | <input type="checkbox"/> | <input type="checkbox"/> |
| 1403 delivery line<br>DN                   | <input type="checkbox"/> | <input type="checkbox"/> | <input type="checkbox"/> | <input type="checkbox"/> | <input type="checkbox"/> |
| 1404 rotating joints of -<br>delivery line | <input type="checkbox"/> | <input type="checkbox"/> | <input type="checkbox"/> | <input type="checkbox"/> | <input type="checkbox"/> |
| 1405 locking pin of the<br>coupling        | <input type="checkbox"/> | <input type="checkbox"/> | <input type="checkbox"/> | <input type="checkbox"/> | <input type="checkbox"/> |

Notes:

--	--

## Inspection report for concrete booms

Inspection report Nr: \_\_\_\_\_ Boom type: \_\_\_\_\_ Machine-Nr: \_\_\_\_\_

**Error code:**

00 no objections	08 corrosion	16 porous	24 deformation
01 cracks	09 lacquer failures	17 burned through	25 bear movement
02 broken	10 fraying	18 not fixed	26 lubrication
03 leaky	11 scratched	19 clemp	27 readability
04 no function	12 bendet	20 sawing	28 missing components
05 low lifetime	13 noises	21 contaminated	29 hydraulical
06 worn out	14 vibration	22 bad contact	30 electrical
07 dirt	15 miscellaneous	23 temperature	31 reinspection required

<p>1406 end hose safety device <input type="checkbox"/> <input type="checkbox"/> <input type="checkbox"/> <input type="checkbox"/> <input type="checkbox"/></p> <p>1407 reducer <input type="checkbox"/> <input type="checkbox"/> <input type="checkbox"/> <input type="checkbox"/> <input type="checkbox"/></p> <p>1408 gate elbow, elbow 6" <input type="checkbox"/> <input type="checkbox"/> <input type="checkbox"/> <input type="checkbox"/> <input type="checkbox"/></p> <p><b>1500 hydraulic system and hydraulic valves</b></p> <p>1501 Pressure relief valve <input type="checkbox"/> <input type="checkbox"/> <input type="checkbox"/> <input type="checkbox"/> <input type="checkbox"/></p> <p>1502 pressure settings <input type="checkbox"/> <input type="checkbox"/> <input type="checkbox"/> <input type="checkbox"/> <input type="checkbox"/></p> <p>1503 hydraulic lines <input type="checkbox"/> <input type="checkbox"/> <input type="checkbox"/> <input type="checkbox"/> <input type="checkbox"/></p> <p>1504 hand operating-(function) <input type="checkbox"/> <input type="checkbox"/> <input type="checkbox"/> <input type="checkbox"/> <input type="checkbox"/></p> <p>1505 boom control valve <input type="checkbox"/> <input type="checkbox"/> <input type="checkbox"/> <input type="checkbox"/> <input type="checkbox"/></p> <p>1506 hydraulic pump <input type="checkbox"/> <input type="checkbox"/> <input type="checkbox"/> <input type="checkbox"/> <input type="checkbox"/></p> <p><b>1600 electric equipment</b></p> <p>1601 remote control (functions) <input type="checkbox"/> <input type="checkbox"/> <input type="checkbox"/> <input type="checkbox"/> <input type="checkbox"/></p> <p>1602 emergency stop (function) <input type="checkbox"/> <input type="checkbox"/> <input type="checkbox"/> <input type="checkbox"/> <input type="checkbox"/></p> <p>1603 switch for outrigger function <input type="checkbox"/> <input type="checkbox"/> <input type="checkbox"/> <input type="checkbox"/> <input type="checkbox"/></p> <p>1604 switch for boom function <input type="checkbox"/> <input type="checkbox"/> <input type="checkbox"/> <input type="checkbox"/> <input type="checkbox"/></p> <p>1605 wiring harness <input type="checkbox"/> <input type="checkbox"/> <input type="checkbox"/> <input type="checkbox"/> <input type="checkbox"/></p> <p>1606 central lubrication <input type="checkbox"/> <input type="checkbox"/> <input type="checkbox"/> <input type="checkbox"/> <input type="checkbox"/></p>	<p><b>1700 sticker sets</b></p> <p>1701 safety hints <input type="checkbox"/> <input type="checkbox"/> <input type="checkbox"/> <input type="checkbox"/> <input type="checkbox"/></p> <p>1702 description <input type="checkbox"/> <input type="checkbox"/> <input type="checkbox"/> <input type="checkbox"/> <input type="checkbox"/></p> <p>1703 operating <input type="checkbox"/> <input type="checkbox"/> <input type="checkbox"/> <input type="checkbox"/> <input type="checkbox"/></p> <p>1704 short operating instruction <input type="checkbox"/> <input type="checkbox"/> <input type="checkbox"/> <input type="checkbox"/> <input type="checkbox"/></p> <p>1705 sticker „don't use the boom as crane" <input type="checkbox"/> <input type="checkbox"/> <input type="checkbox"/> <input type="checkbox"/> <input type="checkbox"/></p> <p>1706 sticker „guideline operating with boom- and concrete pump" <input type="checkbox"/> <input type="checkbox"/> <input type="checkbox"/> <input type="checkbox"/> <input type="checkbox"/></p> <p>1707 name plate <input type="checkbox"/> <input type="checkbox"/> <input type="checkbox"/> <input type="checkbox"/> <input type="checkbox"/></p> <p>1708 sticker „danger high voltage" <input type="checkbox"/> <input type="checkbox"/> <input type="checkbox"/> <input type="checkbox"/> <input type="checkbox"/></p> <p><b>Competent inspector:</b></p> <p>Date: _____</p> <p>Name: _____</p> <p>Signature: _____ (stamp)</p> <p><b>Customer:</b></p> <p>Signature: _____ (stamp)</p>
--	---

# Inspection report for concrete pump

Inspection report Nr:	Machine-Nr:	Hours of operation:
		Concrete output m <sup>3</sup> :
Company:	Post code:	City:

NL	WV
----	----

**Proof – Result of the tests**

without defects	defects	reinspection required	shut down
<input type="checkbox"/>	<input type="checkbox"/>	<input type="checkbox"/>	<input type="checkbox"/>

Reinspection until date: .....

**Error code:**

- |                  |                     |                   |                          |
|------------------|---------------------|-------------------|--------------------------|
| 00 no objections | 08 corrosion        | 16 porous         | 24 deformation           |
| 01 cracks        | 09 lacquer failures | 17 burned through | 25 bear movement         |
| 02 broken        | 10 fraying          | 18 not fixed      | 26 lubrication           |
| 03 leaky         | 11 scratched        | 19 clomp          | 27 readability           |
| 04 no fuction    | 12 bendet           | 20 sawing         | 28 missing components    |
| 05 low livetime  | 13 noises           | 21 contaminated   | 29 hydraulical           |
| 06 worn out      | 14 vibration        | 22 bad contact    | 30 electrical            |
| 07 dirt          | 15 miscellaneous    | 23 temperature    | 31 reinspection required |

**2000 documents**

2001 operating manual

2002 spare parts list

**2100 drive assembly**

2101 coupling and flange

2200 gear box

2300 hydraulic pump (main)

2400 oil-tank

2500 drive shaft

**2700 hydraulic control system**

2701 pressure relief valve

2702 pressure setting

2703 hydraulic line

2704 mechanical operation by hand

2800 oil –cooler

2900 accumulator

2901 proofs of the required tests according to accumulator regulation

2902 pressure gauge

Notes:



# Inspection report for concrete pump

Inspection report Nr: \_\_\_\_\_ Machine-Nr: \_\_\_\_\_

**Error code:**

- |                  |                     |                   |                          |
|------------------|---------------------|-------------------|--------------------------|
| 00 no objections | 08 corrosion        | 16 porous         | 24 deformation           |
| 01 cracks        | 09 lacquer failures | 17 burned through | 25 bear movement         |
| 02 broken        | 10 fraying          | 18 not fixed      | 26 lubrication           |
| 03 leaky         | 11 scratched        | 19 clemp          | 27 readability           |
| 04 no function   | 12 bendet           | 20 sawing         | 28 missing components    |
| 05 low lifetime  | 13 noises           | 21 contamitated   | 29 hydraulical           |
| 06 worn out      | 14 vibration        | 22 bad contact    | 30 electrical            |
| 07 dirt          | 15 miscellaneous    | 23 temperature    | 31 reinspection required |

- |                          |                          |                          |                          |                          |                          |
|--------------------------|--------------------------|--------------------------|--------------------------|--------------------------|--------------------------|
| 3000 central lubrication | <input type="checkbox"/> | <input type="checkbox"/> | <input type="checkbox"/> | <input type="checkbox"/> | <input type="checkbox"/> |
| 3100 hydraulic motor     | <input type="checkbox"/> | <input type="checkbox"/> | <input type="checkbox"/> | <input type="checkbox"/> | <input type="checkbox"/> |
| 3200 hydraulic lines     | <input type="checkbox"/> | <input type="checkbox"/> | <input type="checkbox"/> | <input type="checkbox"/> | <input type="checkbox"/> |
| 3300 air compressor      | <input type="checkbox"/> | <input type="checkbox"/> | <input type="checkbox"/> | <input type="checkbox"/> | <input type="checkbox"/> |
| 3400 control panel       | <input type="checkbox"/> | <input type="checkbox"/> | <input type="checkbox"/> | <input type="checkbox"/> | <input type="checkbox"/> |
| 3500 concrete pump       | <input type="checkbox"/> | <input type="checkbox"/> | <input type="checkbox"/> | <input type="checkbox"/> | <input type="checkbox"/> |
| 3700 S-valve             | <input type="checkbox"/> | <input type="checkbox"/> | <input type="checkbox"/> | <input type="checkbox"/> | <input type="checkbox"/> |
| 3800 hopper              | <input type="checkbox"/> | <input type="checkbox"/> | <input type="checkbox"/> | <input type="checkbox"/> | <input type="checkbox"/> |
| 4100 sub frame           | <input type="checkbox"/> | <input type="checkbox"/> | <input type="checkbox"/> | <input type="checkbox"/> | <input type="checkbox"/> |
| 4200 water tank          | <input type="checkbox"/> | <input type="checkbox"/> | <input type="checkbox"/> | <input type="checkbox"/> | <input type="checkbox"/> |
| 4300 axle                | <input type="checkbox"/> | <input type="checkbox"/> | <input type="checkbox"/> | <input type="checkbox"/> | <input type="checkbox"/> |
| 4400 water pump          | <input type="checkbox"/> | <input type="checkbox"/> | <input type="checkbox"/> | <input type="checkbox"/> | <input type="checkbox"/> |
| 4500 vibrator            | <input type="checkbox"/> | <input type="checkbox"/> | <input type="checkbox"/> | <input type="checkbox"/> | <input type="checkbox"/> |

**4600 safety guards, equipment**

- |  |                          |                          |                          |                          |                          |
|--|--------------------------|--------------------------|--------------------------|--------------------------|--------------------------|
| 4601 stair                                       | <input type="checkbox"/> | <input type="checkbox"/> | <input type="checkbox"/> | <input type="checkbox"/> | <input type="checkbox"/> |
| 4602 safety for stair                            | <input type="checkbox"/> | <input type="checkbox"/> | <input type="checkbox"/> | <input type="checkbox"/> | <input type="checkbox"/> |
| 4603 handrail                                    | <input type="checkbox"/> | <input type="checkbox"/> | <input type="checkbox"/> | <input type="checkbox"/> | <input type="checkbox"/> |
| 4604 hopper grid<br>(fixing device)              | <input type="checkbox"/> | <input type="checkbox"/> | <input type="checkbox"/> | <input type="checkbox"/> | <input type="checkbox"/> |
| 4606 distance of grid rods                       | <input type="checkbox"/> | <input type="checkbox"/> | <input type="checkbox"/> | <input type="checkbox"/> | <input type="checkbox"/> |
| 4607 distance from grid to<br>agitator           | <input type="checkbox"/> | <input type="checkbox"/> | <input type="checkbox"/> | <input type="checkbox"/> | <input type="checkbox"/> |
| 4609 agitator have to stop<br>if grid is open    | <input type="checkbox"/> | <input type="checkbox"/> | <input type="checkbox"/> | <input type="checkbox"/> | <input type="checkbox"/> |
| 4610 accumulator have to<br>dump if grid is open | <input type="checkbox"/> | <input type="checkbox"/> | <input type="checkbox"/> | <input type="checkbox"/> | <input type="checkbox"/> |
| 4612 cleaning flap hopper                        | <input type="checkbox"/> | <input type="checkbox"/> | <input type="checkbox"/> | <input type="checkbox"/> | <input type="checkbox"/> |
| 4613 safety grid into water<br>box               | <input type="checkbox"/> | <input type="checkbox"/> | <input type="checkbox"/> | <input type="checkbox"/> | <input type="checkbox"/> |

Notes:

# Inspection report for concrete pump

Inspection report Nr:

Machine-Nr:

**Error code:**

00 no objections	08 corrosion	16 porous	24 deformation
01 cracks	09 lacquer failures	17 burned through	25 bear movement
02 broken	10 fraying	18 not fixed	26 lubrication
03 leaky	11 scratched	19 clemp	27 readability
04 no function	12 bendet	20 sawing	28 missing components
05 low lifetime	13 noises	21 contamitated	29 hydraulical
06 worn out	14 vibration	22 bad contact	30 electrical
07 dirt	15 miscellaneous	23 temperature	31 reinspection required

- 4614 cover for rotating wave
- 4616 cover for chains
- 4617 cover for shift cylinder
- 4618 cover for moving parts
- 4619 cover for the exhaust pipe

**4700 electrical system**

- 4701 function of actuator component
- 4702 emergency stop function
- 4703 ground connections
- 4704 cables and wiring harness
- 4705 temperature switch

**4800 outrigger - system**

- 4801 transportation lock
- 4802 locking device
- 4803 backing plate

- 4804 jack cylinder connections
- 4805 pressure adjustment of jack cylinder
- 4900 miscellaneous**
- 4901 additional assembled part from operator
- 4902 changes through operator

**Competent inspector:**

Date: .....

Name: .....

Signature: .....  
(stamp)

**Customer:**

Signature: .....  
(stamp)

This test report is filed into the test book



**MODEL XT36-160 TRUCK MOUNTED  
CONCRETE BOOM PUMP  
VENDOR SECTION**

**VENDOR**

**FIGURE 00  
PAGE 00**

**REED TRUCK MOUNTED CONCRETE BOOM PUMP MODEL XT36-160  
VENDOR SECTION CONTAINS THE FOLLOWING FIGURES:**

<b>FIGURE 00</b>	TABLE OF CONTENTS
<b>FIGURE 01</b>	MACK TRUCK MR690S T2070 7 SPEED TRANSMISSION
<b>FIGURE 02</b>	BOSTROM AIR SUSPENSION SEAT TALLADEGA SERIES
<b>FIGURE 03</b>	REXROTH A2F HYDRAULIC PUMP MOTOR
<b>FIGURE 04</b>	NBB NANO RADIO REMOTE CONTROL
<b>FIGURE 05A</b>	SAUER SUNDSTRAND HYDRAULIC PUMP SERIES 90
<b>FIGURE 05B</b>	REXROTH A4VG 71-180 HYDRAULIC PUMP SERIES 32
<b>FIGURE 06</b>	STIEBEL POWER TAKE-OFF GEAR
<b>FIGURE 07</b>	CRK WASH WATER PUMP
<b>FIGURE 08</b>	PNN SYSTEM CABLE REMOTE CONTROL



REVISION:



# MODEL XT36-160 TRUCK MOUNTED CONCRETE BOOM PUMP VENDOR SECTION

VENDOR

FIGURE 00  
PAGE 01

**REED**  
CONCRETE PLACING  
EQUIPMENT

**MR SERIES MACK TRUCK**

VENDR  
FIGURE 01  
PAGE 01

**Mack**

THE CUSTOMER SERVICE DEPARTMENT PHO (815) 709-2961.  
When contacting our regional service offices or Cs Department, it is imperative that you provide them information:

- VEHICLE IDENTIFICATION NUMBER (VIN) number is
- MODEL and YEAR of vehicle
- DATE vehicle was PURCHASED and put in
- DATE of REPAIR and REPAIR MILEAGE
- BRANCH or DISTRIBUTOR who sold and/or
- DESCRIPTION of unsolved service complaint
- SUMMARY of ACTION TAKEN to date by the and our regional service office
- NAMES of INDIVIDUALS (if known) contact distributor and the Mack Trucks, Inc. region

**Mack**

INTRODI  
SAFETY  
INSTRUM  
OPERAT  
MAINTEN  
METRIC

REVISION:

**REED**  
CONCRETE PLACING  
EQUIPMENT

**REXROTH A2F HYDRAULIC PUMP MOT**

VENDR  
FIGURE 02  
PAGE 01

**A2F**  
Baurohr/Seri



**MANNESMANN REXROTH**  
Hydromatik

**R**

NOTE  
Pre-treated and pre-assembled Original-Hydromatik sub-assemblies mean quick and successful repairs possible. Should it be necessary to carry out repairs with individual components, our experience shows that only Original-Hydromatik seals, retaining rings, and bearings should be used. Basically, stress should be changed when ever a unit is stripped down, as useful life skills remaining cannot be visually determined. In addition, it should be disassembling to spot a well done repair by including maintainable repair components. Giving us the unit type and fabrication number when ordering components will mean that you receive them quickly. Repairs are simple, but we recommend you take advantage of our training in order to acquire the necessary special knowledge. This applies also to specialists whom we are always pleased to meet again to retain the repair of newly developed products.

REVISION:

**REED**  
CONCRETE PLACING  
EQUIPMENT

**BOSTROM AIR SUSPENSION SEAT  
TALLADEGA SERIES**

VENDR  
FIGURE 02  
PAGE 01

**Bostrom**  
SEATING



**TALLADEGA**  
SERIES  
905L/905/910  
AIR SUSPENSION SEATS

REVISION:

REVISION:



**THE CUSTOMER SERVICE DEPARTMENT PHONE NUMBER IS  
(610) 709-3961.**

When contacting our regional service offices or Customer Service Department, it is imperative that you provide them with the following information:

- VEHICLE IDENTIFICATION NUMBER (VIN) — This 17-digit number is
  
- MODEL and YEAR of vehicle
- DATE vehicle was PURCHASED and put into service
- DATE of REPAIR and REPAIR MILEAGE
- BRANCH or DISTRIBUTOR who sold and/or serviced the vehicle
- DESCRIPTION of unresolved service complaint or inquiry
- SUMMARY of ACTION TAKEN to date by the branch or distributor and our regional service office
- NAMES of INDIVIDUALS (if known) contacted at the branch or distributor and the Mack Trucks, Inc. regional service office



**TABLE OF CONTENTS**

**INTRODUCTION ..... 02**

**SAFETY INFORMATION ..... 05**

**INSTRUMENTS AND CONTROLS..... 18**

**OPERATION ..... 25**

**MAINTENANCE AND LUBRICATION ..... 49**

**METRIC CONVERSIONS..... 58**



# REED

CONCRETE PLACING  
EQUIPMENT

## MR SERIES MACK TRUCK

VENDR

FIGURE 01  
PAGE 03

### INTRODUCTION



#### WARRANTY

#### Injection Pump and Governor Settings

### CAUTION

*Any unauthorized adjustments of the injection pump and governor settings, other than as specified, can cause serious damage to the engine.*

Please be aware of the hazards of attempting to increase the power of the diesel engine in your chassis by adjusting injection pump and governor settings. Standard specifications for injection pump and governor settings permit the maximum allowable engine output. Adjustments of the injection pump and governor settings, other than as specified, can cause serious damage to the engine. In some engines, improper adjustments generally produce visual evidence of over-fueling, excessive fuel consumption and smoke. The turbocharged diesel engine usually does not produce visual evidence. The possibility of damage from improper adjustments is greater in the turbocharged diesel engine because the usual warning signs may not be present.

In the event that damage results from such unauthorized adjustments, as evidenced by improper settings in the injection pump and governor assembly or broken fastener seals of the same, the cost of repairing such damage will NOT be covered under the MACK Standard Vehicle Warranty.

### INTRODUCTION



#### Engine Information Plate

In compliance with the emissions standards requirements, an engine exhaust emissions control plate is affixed to one of the engine cylinder head covers for all MACK E7 and E9 (if equipped) diesel engines. This plate gives basic engine identification information and specifications for injection pump-to-engine timing and valve clearances.

The MACK E7 engine is shown for example purposes, where the information plate is found on the forward cylinder head cover.

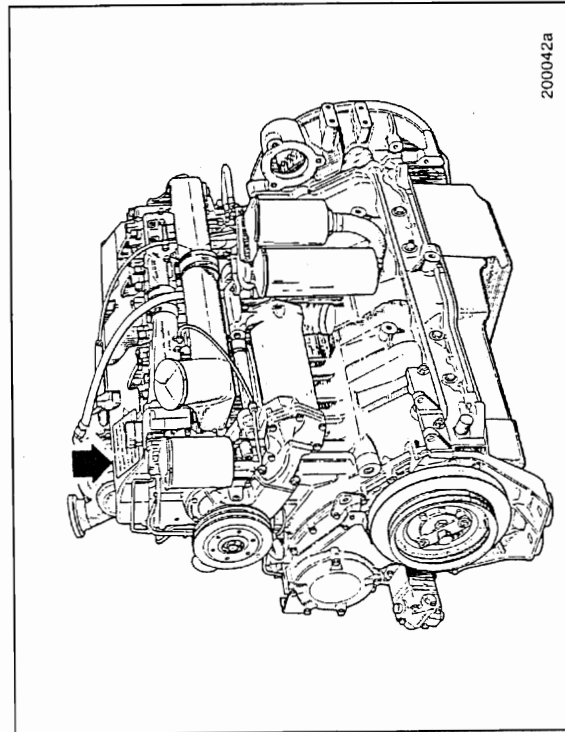

**REED**CONCRETE PLACING  
EQUIPMENT**MR SERIES MACK TRUCK****VENDR**FIGURE 01  
PAGE 04**INTRODUCTION****CUSTOMER SERVICE****Questions and Complaints**

Your satisfaction with the vehicle or service parts you purchase, and the service you receive at a Mack Trucks, Inc. subsidiary, distributor or service dealer, are our most important concerns.

If questions or complaints arise, we suggest that you first discuss the matter with the service manager at the MACK facility involved. If you are not satisfied with the service manager's response, contact the branch manager, principal or general manager of the distributorship, explain the situation and request assistance. Those requiring assistance at a service dealer should speak with the owner of the establishment.

If, for any reason, you need further assistance after dealing with the personnel at a MACK subsidiary or distributor, contact the nearest MACK regional service office and address your problem or request to our regional service manager. The regional service manager has the responsibility and the authority to recommend action in most cases and (with the aid of relevant district service personnel) will make every effort to conduct a fair review of your situation.

**Addresses**

The addresses and telephone and fax numbers of the Mack Trucks, Inc. regional offices are:

**United States**

**Northeast Region** — 2166 S. 12th St., P.O. Box M, Allentown, PA 18105-5000, TEL: (610) 709-3419, FAX: (610) 709-2220

**Southeast Region** — 6768 Southlake Parkway, Morrow, GA 30260, TEL: (770) 960-0511, FAX: (770) 960-0593

**Central Region** — 900 S. Frontage Rd., Suite 100, Woodridge, IL 60517, TEL: (708) 910-3330, FAX: (708) 910-3331

**Southwest Region** — 5605 N. MacArthur Blvd., #550, P.O. Box 165408, Irving, TX 75016-5408, TEL: (214) 518-1614, FAX: (214) 550-0389

**Western Region** — 20201 Mack St., P.O. Box 56658, Hayward, CA 94545-6658, TEL: (510) 732-0680, FAX: (510) 785-3803

**INTRODUCTION****Air Brake System**

The MACK Standard Vehicle Warranty applies to the air brake system, as set forth in the Warranty, but only if the air brake system has not been subjected to unauthorized additions, deletions or modifications. If any such unauthorized additions, deletions or modifications are performed to the air brake system, Mack Trucks, Inc. disclaims any and all liability for any loss or damage arising out of a malfunction of the air brake system.

The air brake system was designed and built to conform to all applicable federal motor vehicle safety standards in effect at the time of manufacture. Tractor air systems are designed for operation as a tractor only, and truck air systems are designed to be operated as a truck only. If a tractor is going to be converted for operation as a truck, the air brake system must be reconfigured to that of a truck. Conversely, if a truck is going to be converted for operation as a tractor, the air system must be reconfigured to that of a tractor. Consult your MACK trucks distributor for additional information.

If any unauthorized additions, deletions or modifications are made to any portion of the air brake system which is required by Federal Motor Vehicle Safety Standards, Mack Trucks, Inc. makes no representation as to conformity with the Standards.

For complete warranty information, refer to Pedigreed Protection Plan (TS468) or Standard Vehicle Warranty (Form F034) furnished with your truck.





# MR SERIES MACK TRUCK

VENDR  
FIGURE 01  
PAGE 05



## SAFETY INFORMATION

### CERTIFICATION LABELS

#### Safety Certification Label

National Highway Traffic Safety Administration (NHTSA) regulations require affixing a certification label to all vehicles.

NHTSA regulations also require that the certification label be affixed to either the hinge pillar, door latch post or the door edge that meets the door latch post next to the driver seat. If none of these locations are practical, it may be attached to the left side of the instrument panel or to an inward facing surface of the driver-side door.

In compliance with NHTSA regulations, your MR has a safety certification label affixed in one of the NHTSA locations listed above. This label may be either an Incomplete Vehicle and/or Completed Vehicle label. Both labels are described below.

#### Incomplete Vehicles

CHASSIS-CAB MANUFACTURED BY MACK TRUCKS, INC. DATE: 03/1996

THIS CHASSIS-CAB CONFORMS TO FEDERAL MOTOR VEHICLE SAFETY STANDARDS NOS. 101, 102, 103, 104, 106, 107, 111, 113, 115, 116, 124, 205, 206, 207, 208, 209, 210, AND 302.

THIS VEHICLE WILL CONFORM TO STANDARDS NOS. 108, 120, AND 123 IF IT IS COMPLETED IN ACCORDANCE WITH THE INSTRUCTIONS ON THIS LABEL AND THE OTHER SAFETY STANDARDS APPLICABLE TO THIS VEHICLE WHEN COMPLETED IS NOT SUBSTANTIALLY AFFECTED BY THE DESIGN OF THE CHASSIS-CAB.

VEHICLE IDENTIFICATION NUMBER (VIN): 1M2AA10YX1W0086Z 4MR3256

000249a

A chassis-cab is an incomplete vehicle with a completed occupant compartment that requires the addition of cargo-carrying, work-performing or load-bearing components to perform its intended functions.

The chassis-cab manufacturer must affix a label to the incomplete vehicle in one of the NHTSA locations listed above. This label provides the chassis-cab date of manufacture, VIN and vehicle certification information.



## SAFETY INFORMATION

### SAFETY STATEMENT

Mack Trucks, Inc. cannot anticipate every possible occurrence which may involve a potential hazard. An accident can be avoided by recognizing potentially hazardous situations before an accident occurs. Correctly performed service procedures are critical for technician safety and safe, reliable operation of the vehicle.



*Driver attitude is the most important part of any effective vehicle safety system. Mack Trucks, Inc. strongly encourages all drivers and passengers to use their seat belts, drive defensively, remain alert and respect the speed limits. Many accidents can also be avoided through regular vehicle maintenance.*

Certain everyday procedures like washing your truck and cleaning the windshield can also be hazardous because of the vehicle's height. Mack Trucks, Inc. does NOT recommend climbing up on your truck to perform these operations! Instead, stand on the ground and use brushes and squeegees mounted on extension poles. When better access is necessary (for instance, when washing the cab roof), use sturdy ladders held in place by someone on the ground.

# REED

CONCRETE PLACING  
EQUIPMENT

## MR SERIES MACK TRUCK

VENDR

FIGURE 01  
PAGE 06

### SAFETY INFORMATION



#### ADVISORY LABELS

Throughout this book you will find paragraphs labeled *Service Hint*, *Note*, *Caution*, *Warning* and *Danger*. *Caution* and *Warning* labels are also found in various locations on the vehicle to alert drivers, operators and service technicians to situations which can cause personal injury or equipment damage. The labels shown are applicable to the MR model chassis at the time of publication and they are representative of what can be typically found on an MR. (Your vehicle may not contain all of the labels illustrated in this handbook.) These labels are for your benefit. Please look through this section and make a mental note of the labels, their locations and what they explain. Be sure to replace any label that is damaged.

### SAFETY INFORMATION



#### Completed Vehicles

In addition to the label supplied by Mack Trucks, Inc. as the chassis-cab manufacturer, a Completed Vehicle certification label, supplied by the body manufacturer, is affixed in the same general location. This label provides information pertaining to Gross Vehicle Weight Rating (GVWR), Gross Axle Weight Rating (GAWR), tire and rim information, etc.

On **MACK-completed vehicles**, this label contains the date of manufacture, VIN, GVWR, GAWR, and tire and rim data. It is found in one of the NHTSA locations listed above.

MACK VEHICLES BY MACK TRUCKS, INC. IN 03/1998		GVWR		MS		MS		MS	
THIS VEHICLE CONFORMS TO ALL APPLICABLE U.S. FEDERAL MOTOR VEHICLE SAFETY STANDARDS IN EFFECT ON THE DATE OF MANUFACTURE SHOWN ABOVE		11924.5 G		11924.5 G		11924.5 G		11924.5 G	
		TIRES		TIRES		TIRES		TIRES	
FRONT	5443 KG (12000 LB) WITH (0.6) WITH	24.5 X 8.25	AT	724 KPA (105 PSI) COLD	SINGLE	24.5 X 8.25	AT	724 KPA (105 PSI) COLD	SINGLE
2ND INT	8818 KG (19400 LB) WITH (0.6) WITH	24.5 X 8.25	AT	724 KPA (105 PSI) COLD	DUAL	24.5 X 8.25	AT	724 KPA (105 PSI) COLD	DUAL
REAR MOST	8818 KG (19400 LB) WITH (0.6) WITH	24.5 X 8.25	AT	724 KPA (105 PSI) COLD	DUAL	24.5 X 8.25	AT	724 KPA (105 PSI) COLD	DUAL
VEHICLE TYPE: TRUCK-TRACTOR									

THIS VEHICLE CONFORMS TO ALL APPLICABLE STANDARDS PRESCRIBED UNDER THE CANADIAN MOTOR VEHICLE SAFETY REGULATIONS IN EFFECT ON THE DATE OF MANUFACTURE. VEHICULE EST CONFORME A TOUTES LES REGLEMENTATIONS EN VIGUEUR AU CANADA EN LA DATE DE SA FABRICATION.

MACK VEHICLES BY MACK TRUCKS, INC. IN 03/1998		GVWR		MS		MS		MS	
THIS VEHICLE CONFORMS TO ALL APPLICABLE U.S. FEDERAL MOTOR VEHICLE SAFETY STANDARDS IN EFFECT ON THE DATE OF MANUFACTURE SHOWN ABOVE		11924.5 G		11924.5 G		11924.5 G		11924.5 G	
		TIRES		TIRES		TIRES		TIRES	
FRONT	5443 KG (12000 LB) WITH (0.6) WITH	24.5 X 8.25	AT	724 KPA (105 PSI) COLD	SINGLE	24.5 X 8.25	AT	724 KPA (105 PSI) COLD	SINGLE
2ND INT	8818 KG (19400 LB) WITH (0.6) WITH	24.5 X 8.25	AT	724 KPA (105 PSI) COLD	DUAL	24.5 X 8.25	AT	724 KPA (105 PSI) COLD	DUAL
REAR MOST	8818 KG (19400 LB) WITH (0.6) WITH	24.5 X 8.25	AT	724 KPA (105 PSI) COLD	DUAL	24.5 X 8.25	AT	724 KPA (105 PSI) COLD	DUAL
VEHICLE TYPE: TRUCK-TRACTOR									

000250a

**SAFETY INFORMATION**



**Advisory Label Location (On Truck)**

Labels Found on Chassis

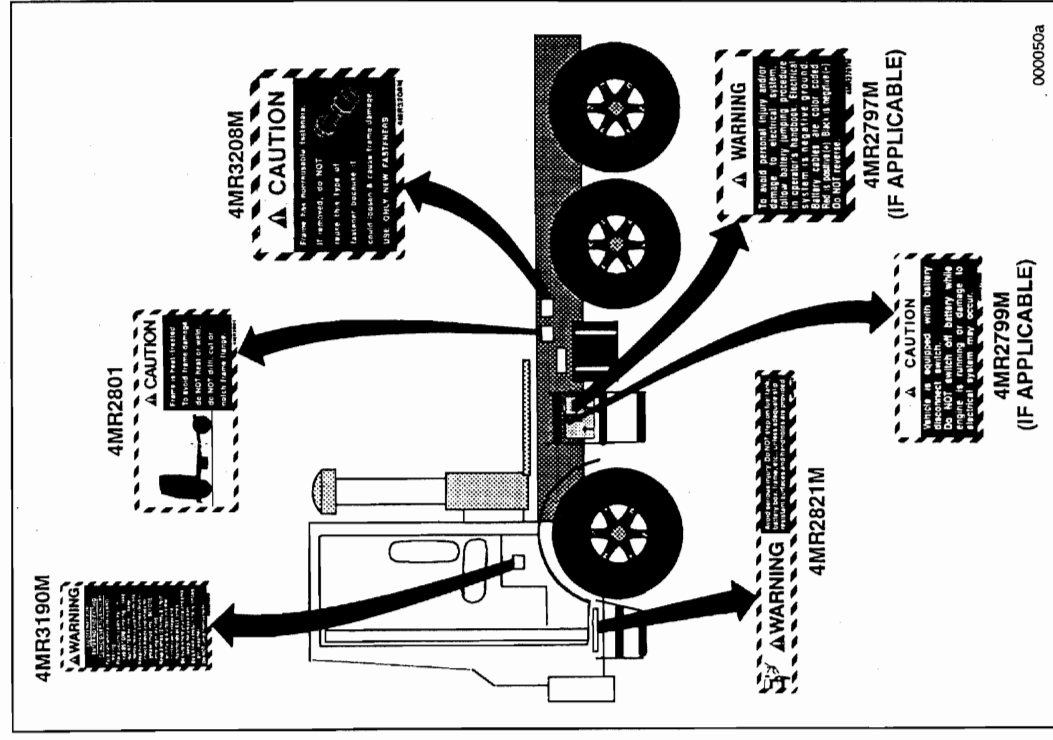

000050a

**SAFETY INFORMATION**



**Advisory Label Location (In Handbook)**

Cautionary signal words (Danger-Warning-Caution) may appear in various locations throughout this manual. Information accented by one of these signal words must be observed to minimize the risk of personal injury to service personnel, or the possibility of improper service methods which may damage the vehicle or render it unsafe. Additional Notes and Service Hints are utilized to emphasize areas of procedural importance and provide suggestions for ease of repair. The following definitions indicate the use of these advisory labels as they appear throughout the manual:

**CAUTION**  
Directs attention to unsafe practices which could result in damage to equipment and possible subsequent personal injury or death if proper precautions are not taken.

**WARNING**  
Directs attention to unsafe practices which could result in personal injury or death if proper precautions are not taken.

**DANGER**  
Directs attention to unsafe practices and/or existing hazards which will result in personal injury or death if proper precautions are not taken.

**NOTE**  
An operating procedure, practice, condition, etc., which is essential to emphasize.

**SERVICE HINT**  
A helpful suggestion which will make it quicker and/or easier to perform a certain procedure, while possibly reducing overhaul cost.

000084a



# REED

CONCRETE PLACING  
EQUIPMENT

## MR SERIES MACK TRUCK

VENDR

FIGURE 01  
PAGE 09

### SAFETY INFORMATION



#### CAB ENTRY/EXIT

##### Three-Limb Contact

When entering or exiting a cab, the driver and/or passenger must have at least three limbs in contact with the vehicle or ground at all times. This means that a minimum of two hands and one foot, or one hand and two feet must be in FIRM contact with the vehicle or ground to avoid accidents due to carelessness.

### WARNING

When entering or exiting the cab, be aware of the condition of steps and handrails, especially in cold weather. During cold weather operations, ice and snow may accumulate and should be cleaned off to prevent slipping.

During cold, wet conditions when ice, slush, or snow may accumulate on the cab doorstep and other external surfaces, extra caution must be observed when entering or exiting the cab.

### SAFETY INFORMATION



#### Labels Found on Windshield

##### CAUTION

This tractor has an air brake system designed for TRACTOR OPERATION ONLY. If this tractor is converted for operation as a TRUCK, the air brake system MUST be changed to provide SAFE OPERATION as a TRUCK. Contact your MACK Dealer for instructions.

DO NOT remove until delivered to the ultimate consumer.

44071037

##### CAUTION

This truck has an air brake system designed for TRUCK OPERATION ONLY. If this truck is converted for operation as a TRACTOR the air brake system MUST be changed to provide SAFE OPERATION as a TRACTOR. Contact your MACK Dealer for instructions.

DO NOT remove until delivered to the ultimate consumer.

44071031

000247a

### NOTE

Label to be removed upon delivery to the end user.  
Refer to page 11 for additional information.

**SAFETY INFORMATION****SAFETY INFORMATION****WARNING**

To avoid injury, use the following guidelines when entering and exiting the cab:

- Face the cab when entering and exiting.
- Keep hands free to grip handholds. Place papers, coats, etc., in the cab before entering, and remove after exiting.
- Keep hands and shoes clean. Check hands and shoes for grease, mud, etc., before entering and exiting to avoid slipping.
- Do NOT jump from the vehicle.
- Do NOT step on the fuel tank, battery box, frame, etc., unless adequate slip-resistant surfaces and handholds are provided.
- Be aware of the condition of steps and handholds, especially in rainy or snowy weather. Clean grease, oil, mud, snow, ice, etc., from steps and handholds before entering and exiting to avoid slipping.

**NOTE**

The illustrations on the following pages are typical for purposes of emphasizing a safe method for hand/foot placement and movement during cab entry/exit. Your truck may not look exactly like the one pictured.

**NOTE**

The arrows in the illustrations are intended to show movement. Notice that three-limb contact is maintained even when one foot, or one hand, is moving.

### SAFETY INFORMATION



### SAFETY INFORMATION



#### Left Side

The following cab entry and exit procedures, along with the safety guidelines outlined in Three-Limb Contact earlier in this section, can be used with your MACK truck.

#### Entry

These entry procedures are illustrated on the following page:

1. With both feet firmly on the ground, grab the outside handhold with both hands or grab the outside handhold with one hand and grab the steering wheel or inside handhold (if equipped) with the other hand. Then raise one foot to the bottom step. (See figure 1.)
2. Maintain a firm grip on the handholds and/or steering wheel and raise your other foot to the top step. If the truck has only one step, go on to step 3. (See figure 2.)
3. While still gripping the handholds and/or steering wheel, raise one foot to the cab floor. (See figure 3.)
4. Move one hand at a time to the steering wheel, inside handhold (if equipped) or cab interior. Bring the other foot inside the cab and sit down. (See figure 4.)

#### Exit

To exit, follow the illustrations in reverse order:

1. With both hands gripping the steering wheel, inside handhold (if equipped) or cab interior, stand up and face the inside of the cab. Move one foot to the top step. (See figure 4.)
2. Move one hand to the outside handhold and grip the steering wheel, inside handhold (if equipped), or cab interior with the other hand. With one foot firmly on the top step, lower the other foot to the bottom step. If the truck has only one step, lower the other foot to the ground and go on to step 4. (See figure 3.)
3. Maintain a firm grip on the handholds and/or steering wheel, and keep one foot firmly on the bottom step. Then lower the other foot to the ground. (See figure 2.)
4. With both hands firmly gripping the handholds and/or steering wheel, lower the other foot to the ground. (See figure 1.)

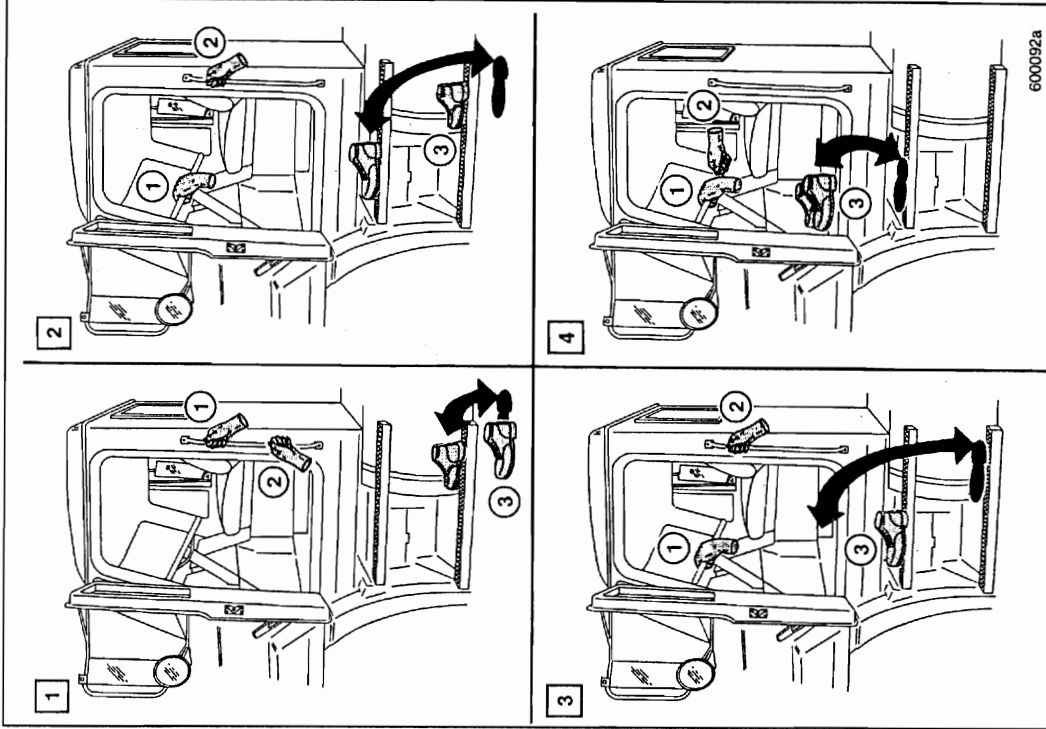

# REED

CONCRETE PLACING  
EQUIPMENT

## MR SERIES MACK TRUCK

VENDR

FIGURE 01  
PAGE 12

### SAFETY INFORMATION



### SAFETY INFORMATION



#### Right Side

The following cab entry and exit procedures, along with the safety guidelines outlined in the Three-Limb Contact section, can be used with any MACK truck. If any of the following entry/exit procedures seem unclear, or if you have any questions, please contact your MACK distributor for assistance.

#### Entry

These entry procedures are illustrated on the following page:

1. With both feet firmly on the ground, grab the outside handhold with both hands, or grab the outside handhold with one hand and grab the inside handhold (if equipped) or cab interior with the other hand. Then raise one foot to the bottom step. (See figure 1.)
2. Maintain a firm grip on the handholds and/or cab interior and raise your other foot to the top step. If the truck has only one step, go on to step 3. (See figure 2.)
3. While still gripping the handholds and/or cab interior, raise one foot to the cab floor. (See figure 3.)
4. Move one hand at a time to the cab interior for support, bring the other foot inside the cab and sit down. (See figure 4.)

#### Exit

To exit, follow the illustrations in reverse order:

1. With both hands gripping the cab interior or inside handhold (if equipped), stand up and face the inside of the cab. Move one foot to the top step. (See figure 4.)
2. Move one hand to the outside handhold and grip the inside handhold (if equipped) or cab interior with the other hand. With one foot firmly on the top step, lower the other foot to the bottom step. If the truck has only one step, lower the other foot to the ground and go on to step 4. (See figure 3.)
3. Maintain a firm grip on the handholds and/or cab interior, and keep one foot firmly on the bottom step. Then lower the other foot to the ground. (See figure 2.)
4. With both hands firmly gripping the handholds and/or cab interior, lower the other foot to the ground. (See figure 1.)

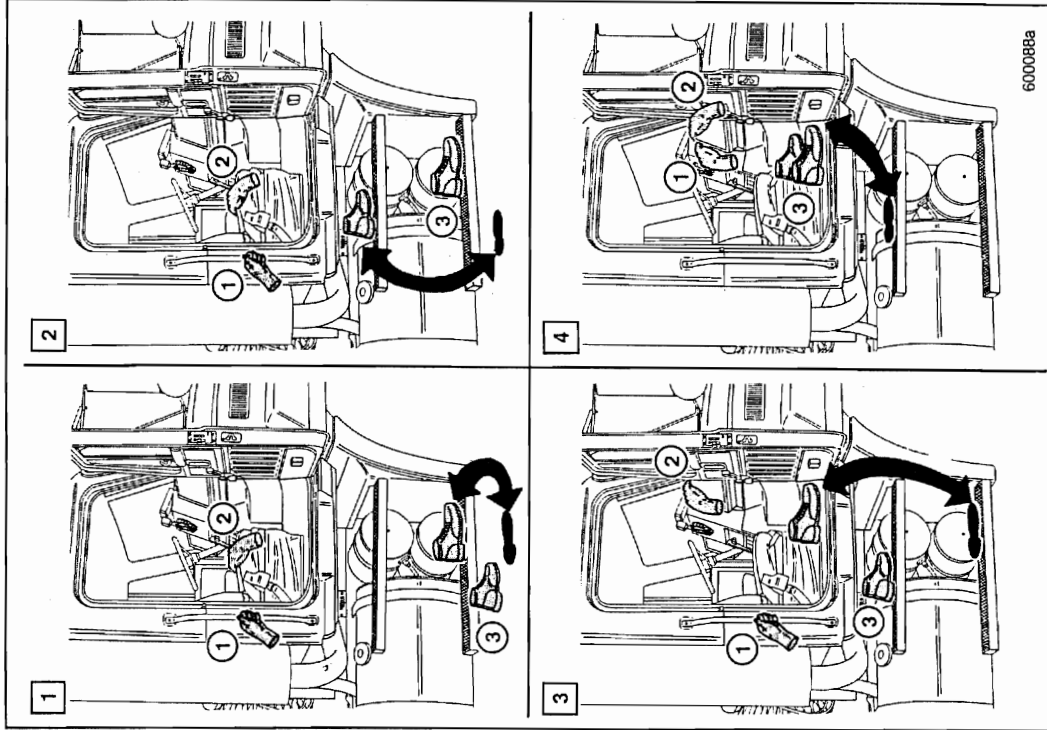



### SAFETY INFORMATION



### SAFETY INFORMATION

#### Cab Door Seals and Key Locks

Hollow-core rubber weather seals around some cab doors may lose their resilience in extremely cold temperatures (i.e., -40°F/ -40°C and below). Under these conditions, it may be necessary to drill holes to penetrate the hollow core. This allows entrapped air to escape, thereby easing the opening/closing of cab door(s).

Be sure to keep the key locks clean and dry to prevent occasional winter freeze-up. Use of antifreeze lubricants is neither required nor recommended.

#### Deck Plate Access

There may be a time when you will need to climb up behind the cab. If your vehicle is equipped with a deck access package, steps and a handhold are provided so you can get to this area safely. Review the rules in the Three-Limb Contact section before climbing behind the cab.

#### Climbing Up

These procedures are illustrated on the following page:

1. Grab the handhold with both hands. Then move one foot to the bottom step. (See figure 1.)
2. While still gripping the handhold, and with one foot planted firmly on the bottom step, move your other foot to the middle step. (See figure 2.)
3. Then with one foot planted firmly on the middle step, move your left foot to the top step. (See figure 3.)
4. Finally, move your other foot from the middle step onto the deck plate. (See figure 4.)

#### Climbing Down

To climb down from behind the cab, follow the illustrations in reverse order:

1. Grab the handhold with both hands and move one foot to the top step. (See figure 4.)
2. While firmly gripping the handhold, and with one foot on the top step, move your other foot to the middle step. (See figure 4.)
3. Then with one foot planted firmly on the middle step, place the other foot on the bottom step. (See figure 3.)
4. With both hands still gripping the handhold, move your other foot from the middle step to the ground. (See figure 2.)
5. Finally, move foot from bottom step to the ground. (See figure 1.)

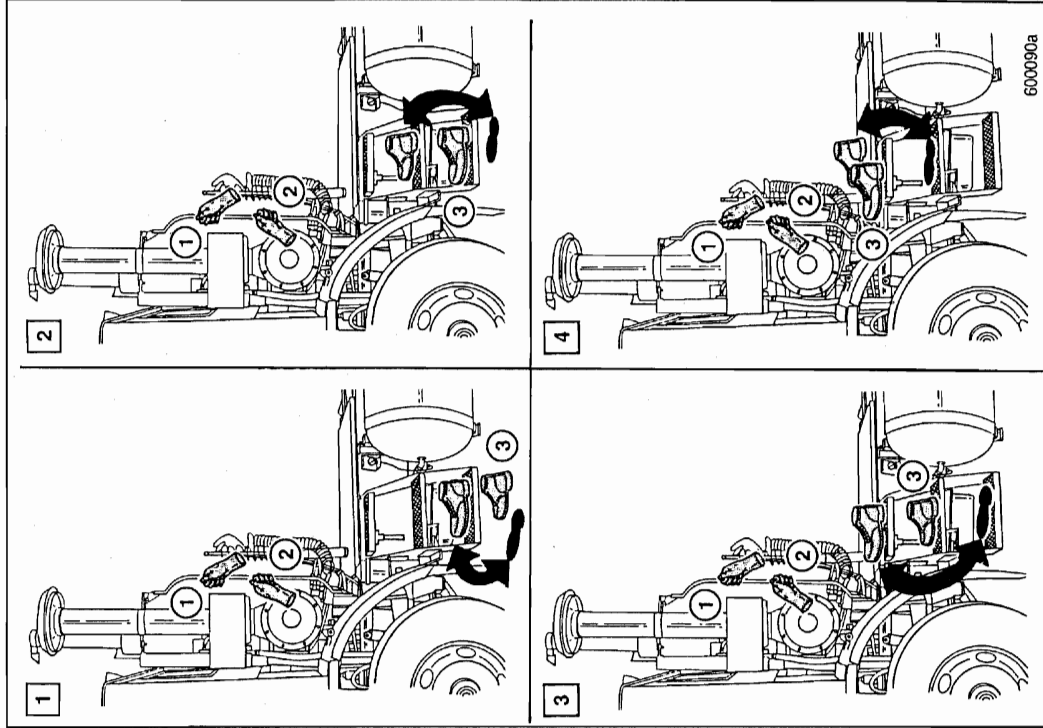

**SAFETY INFORMATION****SEAT BELTS****⚠ DANGER**

*The use of seat belts is required in some states and is strongly recommended at all times, especially during adverse road conditions associated with winter weather. Failure to use seat belts can result in SEVERE bodily injury.*

**Operation**

MACK vehicles manufactured on or after September 1, 1990 must have locking retractable seat belts. For all seating positions on your MACK vehicle, this type of seat belt is a combination lap and shoulder belt.

This type of belt is designed to lock (that is, prevent belt travel out of the retractor) only during sudden stops or impacts. This feature allows the operator to move freely under normal conditions. The seat belts cannot be locked by jerking on the belt, except during sudden stops or harsh bumps.

**Fastening**

1. Pull clip so the belt crosses your shoulder and lap and insert it into the buckle until an audible snap is heard.

**⚠ WARNING**

Use the shoulder belt only on the shoulder that is closest to the vehicle door. Never wear the shoulder portion of the belt under your arm or behind your back. Improper use will increase your chances of injury during a collision.

2. Make sure the clip is securely fastened into the buckle.

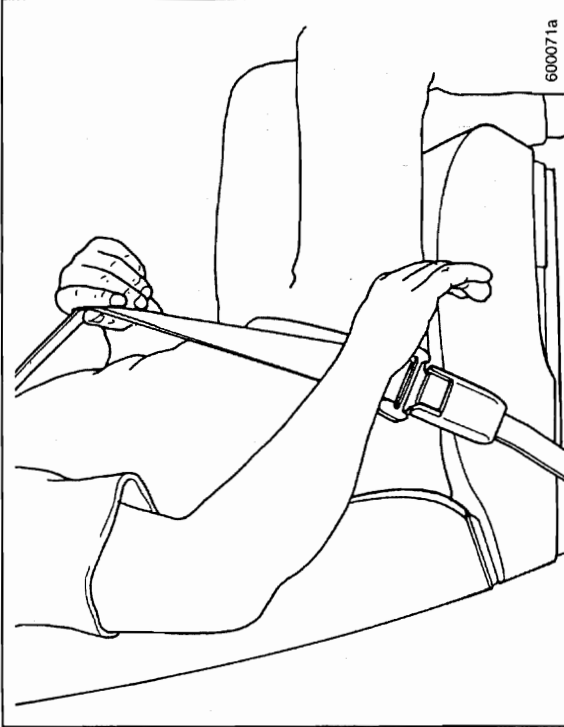

3. To tighten the lap portion of the combination belt, pull upward on the shoulder portion until the lap portion fits you snugly. The belt should rest as low on your hips as possible.

**Unfastening**

Push down on the button to release the belt.

**⚠ WARNING**

Do NOT wear seat belt loosely. Do NOT use one belt for more than one person. Do NOT wear retractor belt with webbing wound on retractor drum. Do NOT bleach or dye belt, as this may cause severe loss of strength. Do NOT install belt in a truck with weakened floor until the floor has been replaced or reinforced.

**SAFETY INFORMATION****Komfort Latch Feature**

If the constant tension of the buckled seat belt causes any discomfort, engage the Komfort Latch as follows:

**WARNING**

**Do NOT attempt to engage the Komfort Latch feature while the truck is in motion.**

**Engagement** — Pull the webbing of the shoulder belt away from the upper torso, pulling only as much slack as needed while still allowing the belt to exert slight pressure against your chest and shoulder. (Maximum amount of slack should not exceed one inch when measured from the chest to the belt.) While holding the slack, lift the lever located on top of the Komfort Latch mechanism upward to clamp the webbing in place.

**Normal Release** — To unfasten the seat belt, simply release the buckle and give the shoulder belt a quick tug to release the Komfort Latch mechanism. Allow the belt to retract into the retractor.

**Emergency Release** — In the event of an emergency, release the seat belt buckle. It is not necessary to release the Komfort Latch in an emergency situation.

**SAFETY INFORMATION****Maintenance**

- Keep belt clean and dry.
- Clean with mild soap solution and lukewarm water.
- Periodically inspect belt, retractor, and mounting points for damage or corrosion that could materially lessen effectiveness of belt installation. Replace all inadequate parts.

**NOTE**

Seat belt assemblies must be replaced after an accident if they have been subjected to loading by occupants (even if no damage is obvious), or if they have been damaged by an accident (bent retractor, torn webbing, etc.). If there is any question regarding belt or retractor condition, replace the appropriate part.

**The Komfort® Latch System****Track III Three-Point Seat Belt Assembly**

The Track III three-point seat belts installed in this chassis are designed to provide the highest degree of operator safety, comfort and convenience. Additional comfort is provided by the Komfort Latch mechanism which is incorporated into the seat belt assembly, and may be used to relieve any discomfort caused by the constant pressure of engaged seat belts.

**Seat Belt Operation**

To buckle the seat belt, grasp the latch portion of the buckle, bring it across your lap (from outboard to inboard) and insert it into the fixed buckle which is mounted to the floor or seat (depending on seat type). With the belt properly latched, the pelvic and upper torso restraints will be in place and automatically adjusted to provide a snug fit.

**SAFETY INFORMATION**



**SAFETY TIPS FOR COLD WEATHER OPERATION**

**Driver Visibility**

Poor driver visibility is not only annoying, but extremely unsafe under any circumstances. Without proper maintenance of visibility-related components, adverse weather conditions such as rain, snow and frost can seriously reduce visibility. Take time before winter arrives to check the following:

- Windshield Wipers
  - Check windshield wiper operation and speeds.
  - Inspect condition and travel of blades. Install new refills for any blades that are cracked, brittle, torn, or coated with road oil along their wiping edge.
- Windshield Washers
  - Check operation of windshield washer.
  - Inspect system hoses and replace if brittle or worn.
  - Inspect washer reservoir. Drain and flush if dirt particles are evident in washer solution.
  - Fill reservoir with commercially available non-freezing type washer fluid.

**CAUTION**

*Do NOT fill reservoir with water only. Even though non-freezing type washer fluid is recommended, do not attempt to clear the windshield of ice by activating the windshield washer and wipers. Ice accumulations should be removed manually by using a scraper.*

**SAFETY INFORMATION**



**NOTE**

If forward movement is required while the Komfort Latch mechanism is latched, the latch automatically releases when you lean against the shoulder portion of the belt. Repeat the above steps to reset the Komfort Latch, if desired, after forward movement is no longer required.

**DANGER**

*Excessive slack will reduce effectiveness of the seat belt, which could result in personal injury and death. CAREFULLY follow the instructions for adjusting the tension-relieving device.*

**SAFETY INFORMATION**



**Outside Mirror Heater**

In areas of frequent snowfall and ice, it may be beneficial to install heated mirrors which will defrost and de-ice cab mirrors. Heated mirrors eliminate the need to pull off the highway and stand on the roadside to scrape ice and snow from the mirrors during winter driving conditions.

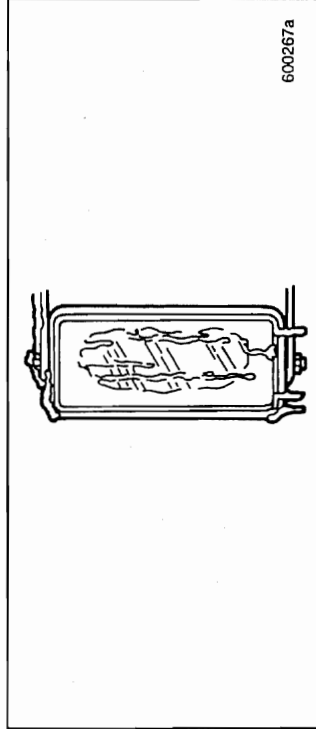

**Air Horn Snow Shield**

To prevent snow from clogging the air horn bell, thereby maintaining maximum sound output in snowy conditions, installation of an air horn snow shield is recommended.

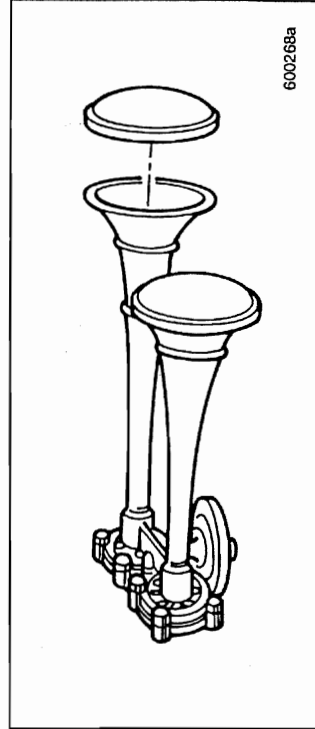

**SAFETY INFORMATION**



• **Heater/Defroster**

- Check operation and blowers for speed control, noise and temperature.
- Inspect heater core for signs of corrosion and/or leakage.
- Check that the defroster blend door is operating correctly and that all ducting is connected properly.
- Be sure that vents are not obstructed by debris or other objects.

**Auxiliary Cab Heater**

Ensure maximum in-cab comfort even under severe cold weather conditions. See your nearest MACK subsidiary or distributor for a wide range of auxiliary in-cab heaters to fit your chassis (see figure below).

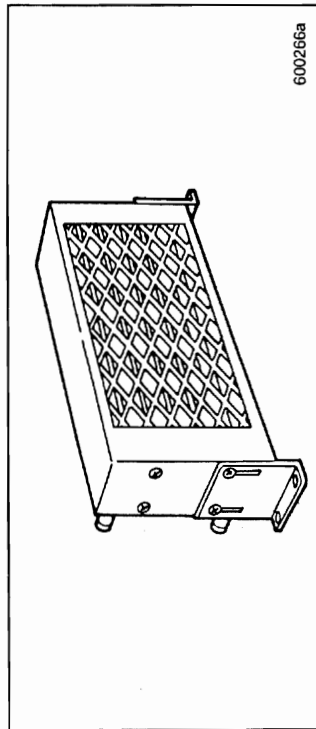

**INSTRUMENTS AND CONTROLS****Panel Arrangement**

Your view from the driver seat should look something like the illustrations shown. The layout has been designed to provide the operator with a good view of the gauges and controls (which are placed so they are within easy reach). The instrument panel, as shown in the following drawing, is broken down into four or five main sections. For easy identification we will refer to them, from left to right, as Panels A, B, C, D and E (where necessary).

**NOTE**

This section is intended to show all the possible instruments and controls available for your truck. However, depending on the options you chose, your truck may not have all of the instruments and controls shown here, and they may not be in exactly the same position.

**INSTRUMENTS AND CONTROLS****INSTRUMENT PANEL****Tell-Tales**

A tell-tale, by definition, is a display that indicates, by means of a light-emitting signal, the actuation of a device, a correct or defective functioning or condition, or a failure to function.

The operator should become familiar with these symbols to recognize and react, if necessary, to the indicated condition.

**Colors**

To promote visual recognition internationally, specific colors for tell-tales have been established. Unless governmental regulations in the area where the vehicle is to be used, or engineering directives specify otherwise, the standard colors are:

- **Blue** — high-beam headlights
- **Flashing Green** — turn signals
- **Flashing Red** — hazard condition involving the safety of personnel
- **Steady Green** — system in operation
- **Steady Red** — warning, immediate action required
- **Amber** — early warning, such as low fuel or anti-lock malfunction

Tell-tale symbols are shown in the instrument panel illustrations on the following pages.

INSTRUMENTS AND CONTROLS



Panel A

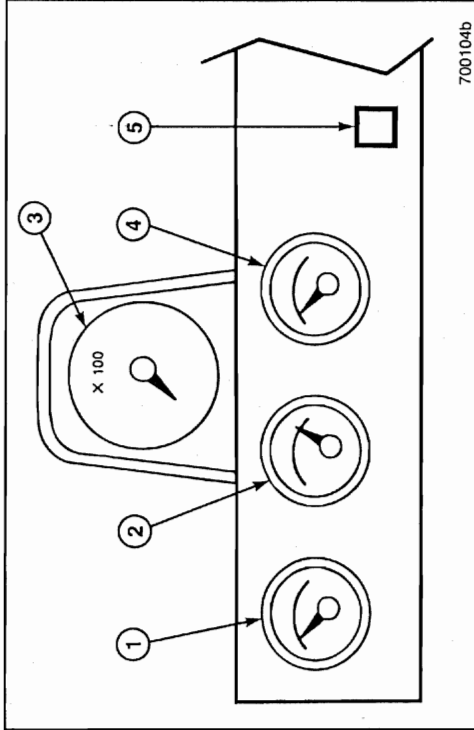

- |                              |                                    |
|------------------------------|------------------------------------|
| 1. Voltmeter                 | 4. Oil Pressure Gauge              |
| 2. Coolant Temperature Gauge | 5. Engine Shutdown Indicator (Red) |
| 3. Tachometer                |                                    |

INSTRUMENTS AND CONTROLS

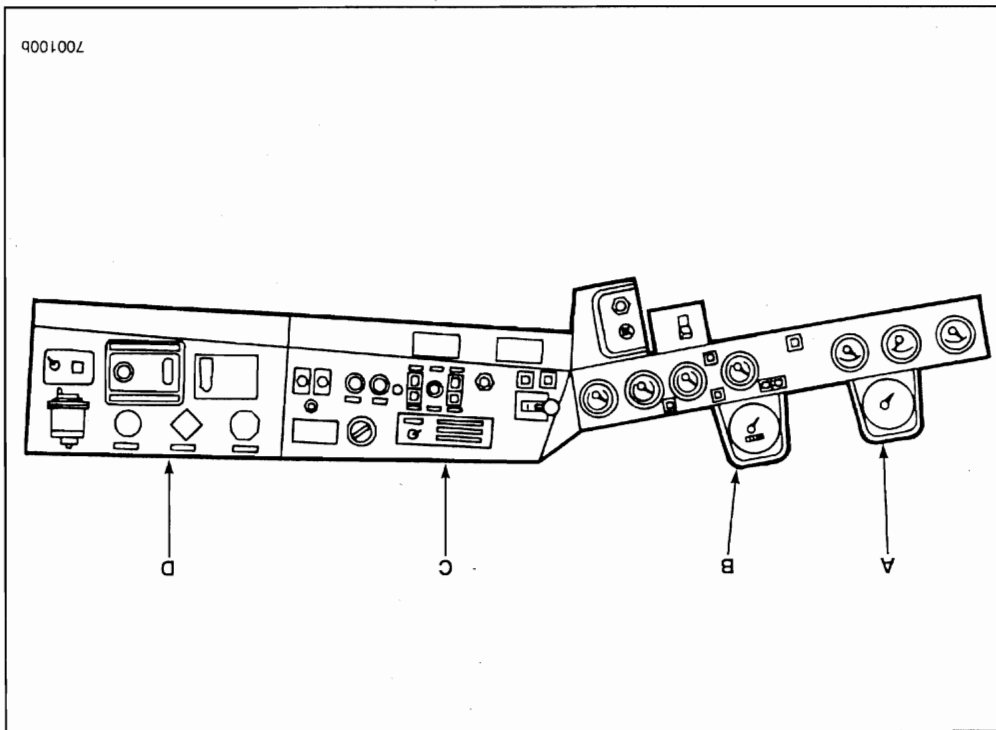

### INSTRUMENTS AND CONTROLS



Panel C

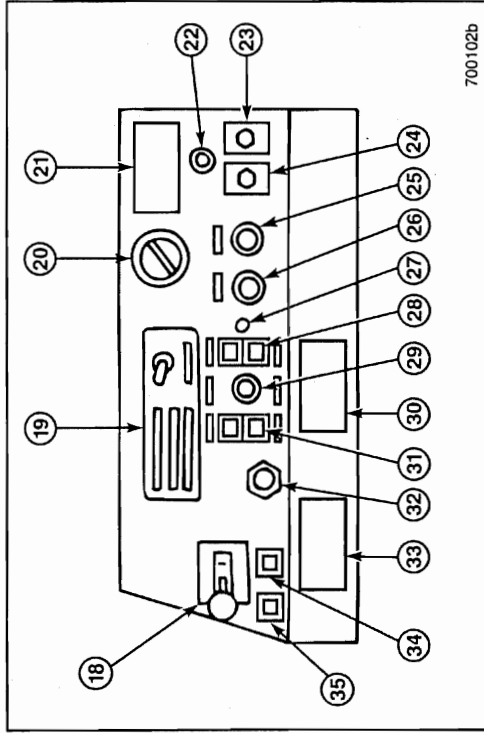

- |  |   |
|--|---|
| 18. Trailer Brake Lever                                | 27. Cigar Lighter   |
| 19. Climate Control Panel                              | 28. Light Switch  |
| 20. Air Vent   | 29. Panel Lights Rheostat                                   |
| 21. Battery Disconnect Switch<br>Caution Label 4MR2799 | 30. Transmission Shifter Neutral<br>Inhibitor Label 4MR2860 |
| 22. Engine Shutdown Override                           | 31. Clearance Light Switch                                  |
| 23. Mirror Defroster Switch                            | 32. Combination Starter and<br>Electrical Switch            |
| 24. Mirror Adjustment Switch                           | 33. PTO Overspeed Label<br>4MR2856                          |
| 25. Right Windshield Wiper/<br>Washer Control          | 34. Power Take-Off Overspeed<br>Warning Indicator (Amber)   |
| 26. Left Windshield Wiper/<br>Washer Control           | 35. Engine Brake Switch                                     |

### INSTRUMENTS AND CONTROLS



Panel B

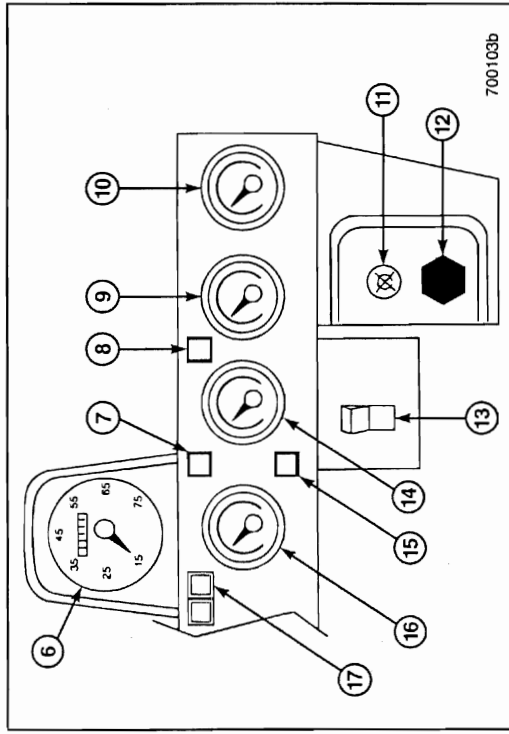

- |                                     |   |
|-------------------------------------|---|
| 6. Speedometer/Odometer             | 12. Throttle (If Equipped)                      |
| 7. Parking Brake Indicator<br>(Red) | 13. Power Take-Off Switch                       |
| 8. High Beam Indicator (Blue)       | 14. Fuel Gauge                                  |
| 9. Hour Meter                       | 15. Low Air Pressure Warning<br>Indicator (Red) |
| 10. Engine Oil Temperature<br>Gauge | 16. Air Pressure Gauge                          |
| 11. Engine Stop Control             | 17. Turn Signal Indicators                      |



**INSTRUMENTS AND CONTROLS**



- ① **Voltmeter** — This gauge indicates the surface charge of the battery with the ignition switch ON and the engine NOT running. With engine running, gauge indicates condition of charging system.  
The voltmeter will provide useful information. When the reading is observed during cranking, the reading normally should not drop below 10 volts. Lower readings indicate corroded connections at the cranking motor or at the battery terminals of defective or discharged batteries.
- ② **Coolant Temperature Gauge** — The normal operating range of a MACK engine, as indicated by the coolant, is between 170°F and 225°F (77°C and 107°C).  
Consult the appropriate vendor engine manual if your vehicle is not equipped with a MACK engine.

**CAUTION**

*Coolant temperature must NOT exceed 225°F (107°C).*

- ③ **Tachometer** — Engine speed is indicated in revolutions per minute (RPM). The tachometer readings should be used as a guide for shifting and to prevent engine damage due to overspeed.
- ④ **Oil Pressure Gauge** — Under normal operating conditions, the engine oil pressure will be between 30 and 84 psi (207 and 579 kPa) at governed speed on a MACK six-cylinder engine, depending on engine type speed and oil viscosity. Oil pressure should be between 10 and 35 psi (69 and 241 kPa) on E7 engines at idling speed.  
E9 engines (if equipped) should be between 25 and 46 psi (172 and 317 kPa) at 600 RPM. At governed speed, a hot oil reading should be between 50 and 100 psi (345 and 690 kPa).  
Should pressure at operating speeds drop suddenly from normal reading, stop engine immediately and determine cause. Other manufacturers' engines may have different requirements and specs. Consult the appropriate manufacturers' engine manuals for their respective pressures.

**INSTRUMENTS AND CONTROLS**

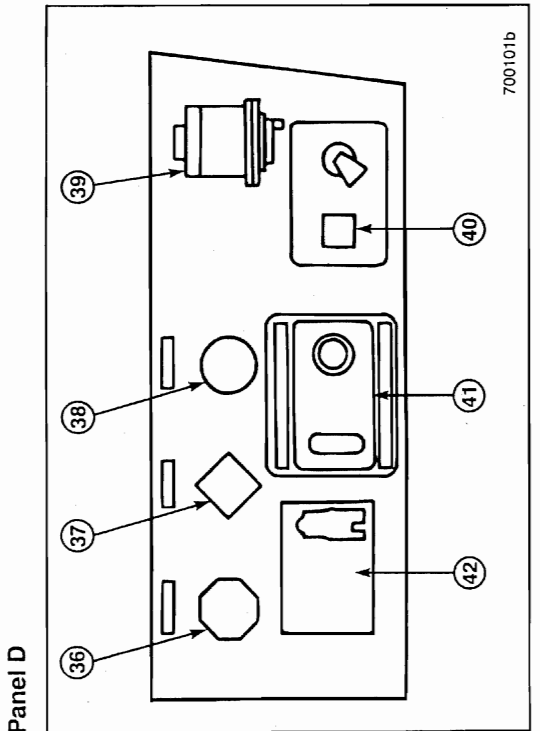

- 36. Trailer Air Supply Valve
- 37. Parking Brake Valve
- 38. Tractor Parking Brake
- 39. Air Filter Restriction Indicator
- 40. Charge Air Cooler Bypass Switch (if Equipped)
- 41. Power Divider Switch
- 42. Power Take-Off Switch

**INSTRUMENTS AND CONTROLS**

- ⑬ **Power Take-Off Switch** — Push top in to turn on; push bottom in to turn off.
- ⑭ **Fuel Gauge** — Registers fuel level in supply tank(s).
- ⑮ **Low Air Pressure Warning Indicator (Red)**
- ⑯ **Air Pressure Gauge** — Normal operating air pressure is between 105 psi (724 kPa) and 135 psi (931 kPa) in both air brake systems. If pressure drops below 75 psi ( $\pm 5$  psi) in either system, the warning buzzer and warning light will go on. Determine the cause of failure before proceeding. Primary air pressure is supplied to the rear brakes and is indicated by the green pointer on the gauge. Secondary air pressure is supplied to the steering axle brakes and indicated by the orange pointer.
- ⑰ **Turn Signal Indicators** — Flash green when the turn signals are activated.
- ⑱ **Trailer Brake Lever** — Pull down to activate the trailer brakes.

**WARNING**

The trailer braking system must NOT be used for parking.

- ⑲ **Climate Control Panel** — See the CLIMATE CONTROL section for more information.
- ⑳ **Air Vent** — Rotate knob to open or close the air vent.
- ㉑ **Battery Disconnect Switch Caution Label 4MR2799** — This label states that "Vehicle is equipped with battery disconnect switch. Do NOT switch off battery while engine is running or damage to electrical system may occur."
- ㉒ **Engine Shutdown Override** — Allows the operator to temporarily override the engine shutdown system for the purpose of moving the vehicle to safety.
- ㉓ **Mirror Defroster Switch** — This is a two-position rocker switch. Push the top to activate outside rearview mirror defrosters. Push the bottom in to turn the mirror defrosters off.

**INSTRUMENTS AND CONTROLS**

- ⑤ **Engine Shutdown Indicator (Red)** — If low water level, low oil pressure or high water temperature occurs, the light will go on. If the vehicle is equipped with the shutdown feature, the driver has about 15 seconds to pull to the side of the road before the engine shuts off.
- ⑥ **Speedometer/Odometer** — Indicates road speed in miles and/or kilometers per hour and total distance vehicle has traveled.
- ⑦ **Parking Brake Indicator (Red)**
- ⑧ **High Beam Indicator (Blue)**
- ⑨ **Hour Meter** — Indicates hours of engine operation. Hours of operation should be used as a guide for certain engine or PTO maintenance operations.
- ⑩ **Engine Oil Temperature Gauge** — Indicates the temperature of the engine oil.

**CAUTION**

*Maximum safe oil temperature is 235° F (113° C). Continued operation with oil above this temperature will cause rapid deterioration of the oil's lubricating properties and is NOT recommended.*

- ⑪ **Engine Stop Control** — Pull out to stop the engine (not used on electronically controlled engines, or chassis having a key switch shut-off feature).
- ⑫ **Throttle (If Equipped)** — Pull out to increase idling speed. Turn clockwise to lock in position.

**WARNING**

The throttle was designed to allow the operator to increase the idle speed of the engine. Uses other than what the throttle was designed for are strictly prohibited. Misuse may cause damage to equipment or even fatal injuries.

### INSTRUMENTS AND CONTROLS



- ②4 **Mirror Adjustment Switch** — This two-position switch allows the operator to adjust the passenger-side rearview mirror.
- ②5 and ②6 **Windshield Wiper/Washer Control** — Push knob in to activate the washers. The 12 o'clock position is OFF. The area between OFF and LOW is intermittent wiper control. Four o'clock position is LOW speed. Five o'clock position is HIGH speed.
- ②7 **Cigar Lighter**
- ②8 **Light Switch** — This is a three-position switch allowing the operator to choose between parking lights (push bottom in), headlights (push top in), or OFF (middle position).
- ②9 **Panel Lights Rheostat** — Clockwise rotation decreases dash light intensity.

#### NOTE

Panel lights will not go on unless Light Switch is ON.

- ③0 **Transmission Shifter Neutral Inhibitor Label 4MR2860** — This label states, "This vehicle is equipped with a transmission shifter neutral inhibitor system. Neutral to Drive range shifts are automatically prevented at high engine speeds. After completing neutral PTO operation, reduce engine speed to below 900 RPM to allow neutral to range shift."
- ③1 **Clearance Light Switch** — This is a two-position switch. Push the top to activate the clearance lights on the tractor and the trailer. Push the bottom to turn the switch OFF.
- ③2 **Combination Starter and Electrical Switch** — When key is straight up and down, the switch is OFF. Turn counterclockwise to activate accessories. To start the engine, turn key clockwise. As soon as the engine starts, release the key (which will automatically return to running position). When switch is turned to ON in either direction, a warning buzzer will sound if air pressure is below  $65 \pm 5$  psi ( $448 \pm 34$  kPa). Buzzer shuts off as soon as sufficient air pressure is restored.
- V-MAC** — For information on the engine protection/shutdown system as it relates to V-MAC, consult TS725 (V-MAC I) or TS780 (V-MAC II).

- ③3 **PTO Overspeed Label 4MR2856** — This label states, "Yellow light indicates PTO overspeed. PTO system is automatically disengaged. To reset, reduce engine speed to idle." This label applies to chassis equipped with a Power-Pro system only.
- ③4 **Power Take-Off Overspeed Warning Indicator (Amber)** — Indicates PTO has automatically disengaged. To reset, reduce engine speed.
- ③5 **Engine Brake Switch** — E7 engines use the Jacobs compression release engine brake, or the Jacobs Stealth Retarding System™. With either system, the best braking performance is achieved in the 1800 to 2100 RPM range. For optimum retarding power, keep engine RPM as close to 2100 RPM as possible. For additional information, refer to the Jacobs driver's manual supplied with the vehicle.

#### CAUTION

Do NOT activate the engine brake until the engine has reached normal operating temperatures.

- ③6 **Trailer Air Supply Valve** — This valve is NOT to be used for parking. Pull to apply trailer emergency brakes. Push to pressurize trailer air reservoir, releasing the trailer emergency brakes.
- ③7 **Parking Brake Valve** — Pull to apply. Push to release. Applies tractor parking brakes and trailer brakes, if attached.
- ③8 **Tractor Parking Brake** — Pull to apply. Push to release.
- ③9 **Air Filter Restriction Indicator** — Indicator shows when the element needs servicing or replacement. When the red flag locks into position, service as soon as possible to prevent engine damage. Then reset the indicator after the filter change. Check the air filter indicator daily.
- ④0 **Charge Air Cooler Bypass Switch (If Equipped)**
- ④1 **Power Divider Switch** — See Inter-Axle Power Divider in the OPERATION section.
- ④2 **Power Take-Off Switch** — Push top in to turn on; push bottom in to turn off.

### INSTRUMENTS AND CONTROLS



#### STEERING COLUMN

##### Turn Signal Lever

#### NOTE

The turn signals are not self-cancelling and must be returned to the middle position manually.

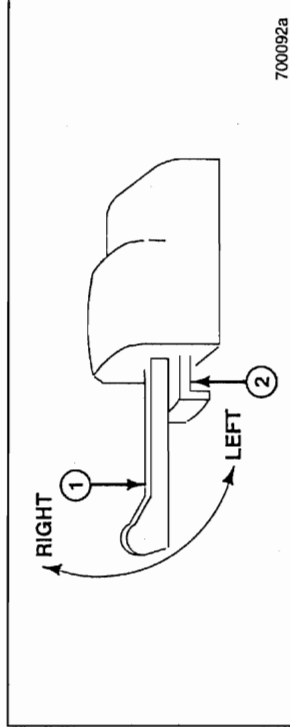

700092a

The turn signal lever is located on the steering column. It incorporates a hazard switch.

- 1 **Turn Signal Lever** — Push lever clockwise to activate right turn signal and counterclockwise to activate left turn signal.
- 2 **Hazard Switch** — Pull out to activate the four-way flasher when required. Flip-turn signal lever forward or back to release.

### INSTRUMENTS AND CONTROLS



#### CLIMATE CONTROL

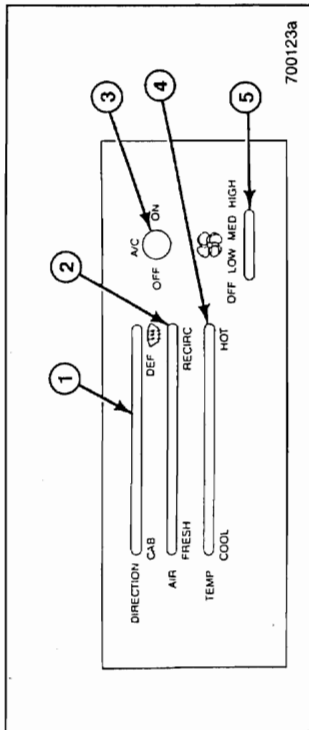

700123a

1. Mode Selection Lever
2. Air Selection Lever
3. A/C On-Off Switch
4. Temperature Control Lever
5. Fan Control Switch

- 1 **Mode Selection Lever** — This lever lets you choose the air direction. The CAB position delivers air to the floor outlets, while the DEF position delivers air to the defrost louvers. Sliding the lever in between positions provides a blend of the two.
- 2 **Air Selection Lever** — This lever lets operator choose between fresh air (from the outside) and recirculated air (within the cab).
- 3 **A/C On-Off Switch** — This switch turns the air conditioner on or off.
- 4 **Temperature Control Lever** — This sliding lever controls the temperature of air from COOL (far left) to WARM (far right).
- 5 **Fan Control Switch** — This is a four-position switch to control the amount of air delivered through the vents. Down is OFF and up is HIGH speed. The middle positions are LOW and MEDIUM speeds.

**OPERATION****Check Fasteners**

- Steering linkage
- Seat belts
- Doors and windows
- Battery box covers
- Fuel tank straps
- Hood or engine compartment covers

**Air Reservoir**

- Drain to remove moisture

**Lights/Reflectors**

- Replace bulbs that aren't working
- Replace broken lenses and reflectors

**Gauges and Instruments**

- Air pressure gauge
- Oil pressure gauge
- Temperature gauge
- Voltmeter

**Check Operation**

- Brakes (service and parking)
- Horn
- Heater and defroster
- Signaling devices
- Windshield wipers/washers
- Foot pedals
- Back-up alarms (if equipped)

**Check Adjustment**

- Rearview mirrors
- Seats

**OPERATION****BEFORE OPERATING YOUR VEHICLE****Daily Walk-Around Inspection**

With the proper care, your MR will work hard and give you years of efficiency and performance — and it is the operator's job to provide the proper care. Good operating habits formed early will make you and your truck a great team.

The driver for each shift should inspect safety equipment, oil and fluid levels and conditions of the following:

**WARNING**

To avoid serious injury, do NOT step on fuel tank, battery box, frame, etc., unless adequate slip-resistant surfaces and handholds are provided.

**Check/Add Fluid**

- Engine oil
- Engine coolant
- Fuel

**Check for Leaks**

- Air, coolant, oil, fuel

**Wheels and Tires**

- Tire air pressure
- Tire/wheel condition
- Wheel stud nuts
- Front wheel bearings (oil)

**MR SERIES MACK TRUCK****OPERATION**

- Report all leaks, loose fasteners, unusual noises, etc., to the service representative at your nearest branch or distributor, so they can be checked and corrected.
- Check spring clip torque (U-bolts). (On Reyco suspensions, also check equalizer nut torque.)
- Check the U-bolt torque on the MACK air suspension at the end of the first 1000 miles (1600 km).

**After the First 3000 Miles (5000 Kilometers) or Before 4000 Miles (6400 Kilometers) or Before 3 to 4 Months**

- Retorque spring clip (U-bolts). (On Reyco suspensions, also retorque equalizer nut.)

**NOTE**

Lubricate the chassis and change the following lubricants and filters according to the Mack preventive maintenance schedules outlined in the MAINTENANCE AND LUBRICATION MANUAL, TS494:

- Gear oils — transmission, rear axle carrier(s), front drive axle carrier, transfer case, flywheel PTO.
- Engine oil, oil filters, fuel filters and coolant conditioner.

**At the First A Inspection Interval**

- Check front and rear axle alignment and adjust if out of specifications.

**OPERATION****New Vehicle Break-In**

Your new MR has been quality built, inspected, lubricated and final adjustments performed at the Mack Trucks Assembly Plant. A proper break-in, along with the following suggestions, can help ensure the long life of your truck.

- As moving parts "wear in," or as gaskets "take a set," an occasional oil, air or coolant leak may develop. Quick action to adjust and correct these minor mechanical items will prevent major repair later, saving you inconvenience and unnecessary expense. So, please stop at your nearest MACK service center as soon as any abnormal condition becomes evident.

**NOTE**

It is important to fill components with lubricants meeting the specifications listed in the Lubricants and Capacities section of the MAINTENANCE AND LUBRICATION manual, TS494.

**NOTE**

All checks and adjustments referred to in this vehicle break-in section can be found in the MAINTENANCE AND LUBRICATION manual, TS494.

**During the First 3000 Miles (5000 Kilometers)**

- After the first 125 miles (200 km), retorque the wheel nuts using an accurately calibrated torque wrench. Recheck this torque again after 500 miles (800 km).
- Check the oil and coolant levels frequently.
- Check brake and clutch adjustments per recommended maintenance schedule, and adjust as needed.
- Observe the instruments often, and shut down at the first sign of any abnormal readings.

**OPERATION****Cab Tilt****⚠ DANGER**

*Before attempting to tilt the cab, be certain to take the following steps:*

- Park on a level surface.
- Shut off engine.
- Secure all loose items within the cab.
- Apply parking brake.
- Place gearshift lever in NEUTRAL position.
- Close cab doors.

The MR cab is mounted on the chassis frame by two front hinges and two rear cab locks. This arrangement allows the cab to tilt forward to a maximum of 60 degrees, exposing the engine compartment for easy accessibility.

The cab tilt system uses one hydraulic cylinder. It incorporates internal safety valves which lock up automatically if the cab moves too rapidly in either direction.

The hydraulic fluid pressure imbalance forces the check valves to seat, holding the cab in a hydraulically locked position. If this situation occurs, operate the pump in the opposite direction to open the check valves. The system will then be returned to normal operation.

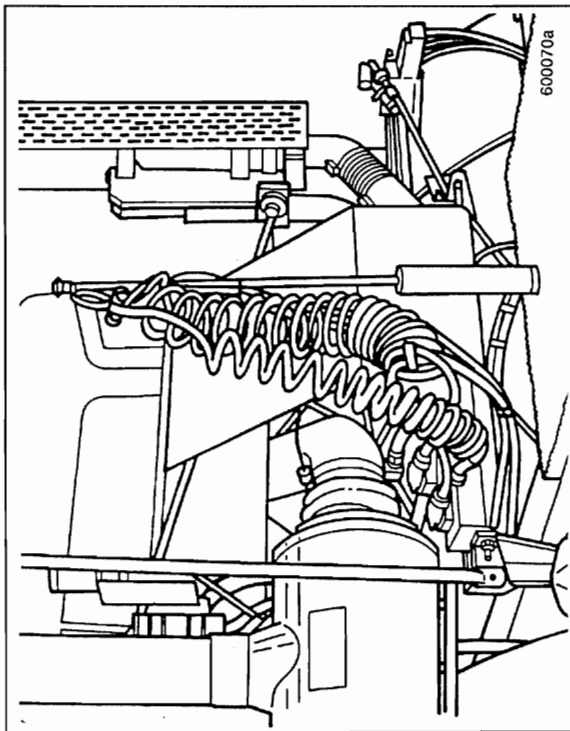
**OPERATION****Hose Tenders****⚠ CAUTION**

*AVOID LOOSE HOSES. Air lines and tractor-to-trailer electrical connections must be secured to the tractor hose tenders (hose hanger, towel bar, pogo stick, etc.) to prevent them from tangling in the driveline.*

**OPERATION**

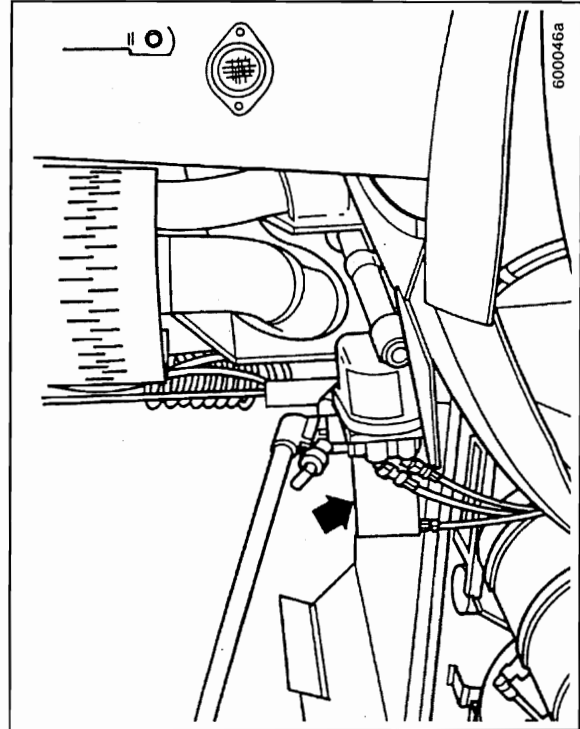

4. To raise to the service position, pump cab up to SERVICE HEIGHT.

**OPERATION**



**Tilting Cab**

Use the following instructions to tilt the cab:

1. Be sure the engine is shut off, and secure all loose items in the cab.
2. Take the cab tilt pump handle from its stored position.

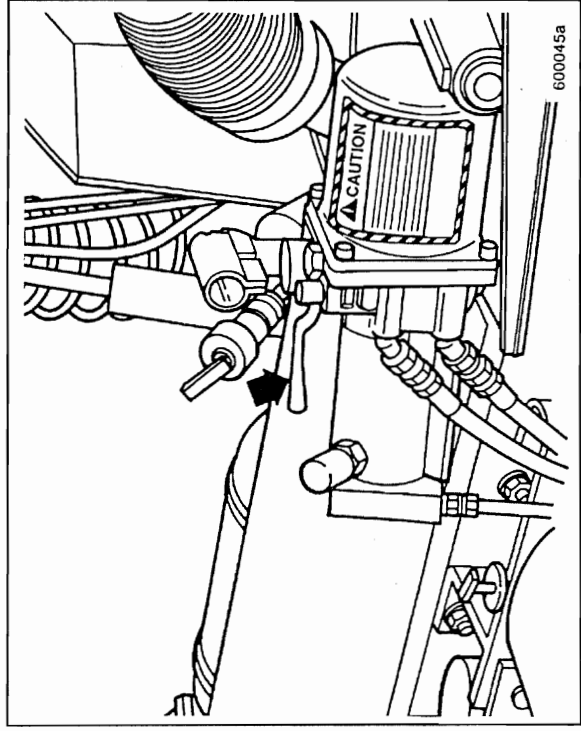

3. Insert the pump handle into the pump and move the pump control lever to the RAISE position.





### OPERATION

5. In the service position, the cab must be secured with the safety prop. Loosen the thumbscrew and swing the safety prop down onto the safety prop stud so the slot in the safety prop settles securely around the stud.

### WARNING

Be certain that there are no people, tools or unsecured vehicle parts in the path of the descending cab before shifting pump control lever.

6. You may have to manipulate the control lever to get the cab to descend so the safety prop settles on the stud (see arrow).
7. To raise the cab to the full tilt position, pump the cab up past the balance point. The cab will descend by itself. The rate of descent may be controlled by manipulating the pump control lever from the RAISE to LOWER position.

### Lowering Cab

### NOTE

The cab safety prop must be in stored position and the transmission in NEUTRAL.

1. Move the pump control lever to the LOWER position.
2. Pump until the cab is past the balance point and allow the cab to descend and latch.
3. Leave the pump control lever in the LOWER position to operate the vehicle.

### OPERATION

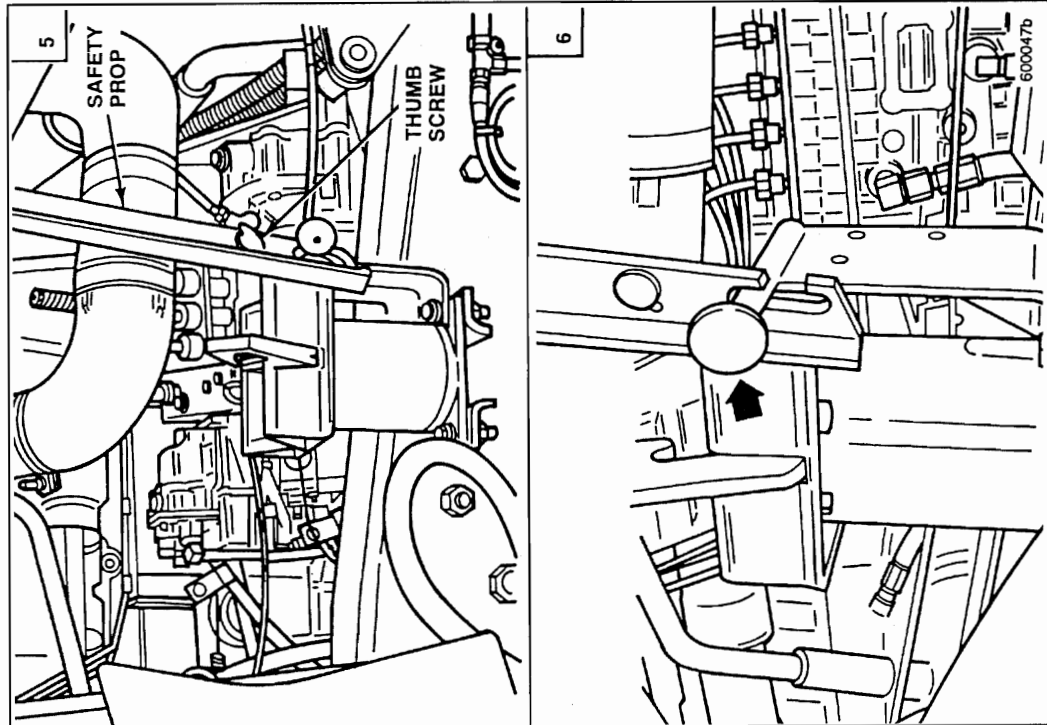



### OPERATION

5. Shift pump control lever to RAISE position. Repeat the procedure in step 4 for the RAISE lines. Bleed latch cylinders first and tighten connections. Repeat for push port of the tilt cylinder.
6. After the entire system is bled, shift pump control lever to LOWER position. Check and refill reservoir, if necessary.

#### SERVICE HINT

The recommended type of fluid for the cab tilt system is CF-A (MIL-H-5606B), capacity 3 pints (1.4 liters).

#### WARNING

The pump control lever must be in the LOWER position before operating the vehicle.



### OPERATION

#### System Bleed Procedure

#### NOTE

The cab must be in the lowered position.

#### NOTE

All steps must be performed in the following order ONLY.

1. Connect all hydraulic lines.
2. Tighten all connections (except two) at the tilt cylinder and one at each latch cylinder.
3. Fill pump reservoir to top with specified oil. Close and tighten fill plug.

#### CAUTION

Do not refill the reservoir with the cab in the RAISE position.

4. Shift pump control lever to LOWER position. Pump until LOWER lines are bled. Tighten corresponding connections.

### OPERATION



#### Power Take-Off

If the vehicle you are operating is equipped with a Power Take-Off (PTO) unit, be sure you read and understand the following section.

#### **⚠ DANGER**

Power Take-Off (PTO) units and their related equipment can be very dangerous. Any PTO installation, repair or replacement should include a warning indicator light which indicates PTO engagement. The light must be located close to the PTO control and clearly visible to the operator.

#### **⚠ DANGER**

PTO units are driven by the engine or drivetrain components (flywheel, crankshaft, transmission). Do not attempt any work or service on the PTO and related units unless the engine is shut down.

#### **⚠ DANGER**

Always keep body parts and loose-fitting clothing out of the range of drivetrain components or personal injury may result.

#### **⚠ DANGER**

Be sure you are aware of the PTO's engagement or non-engagement status and the position of the truck's body (dump body controlled by PTO, etc.). Be sure PTO is disengaged when not in use.

### OPERATION



#### Doors

#### Opening

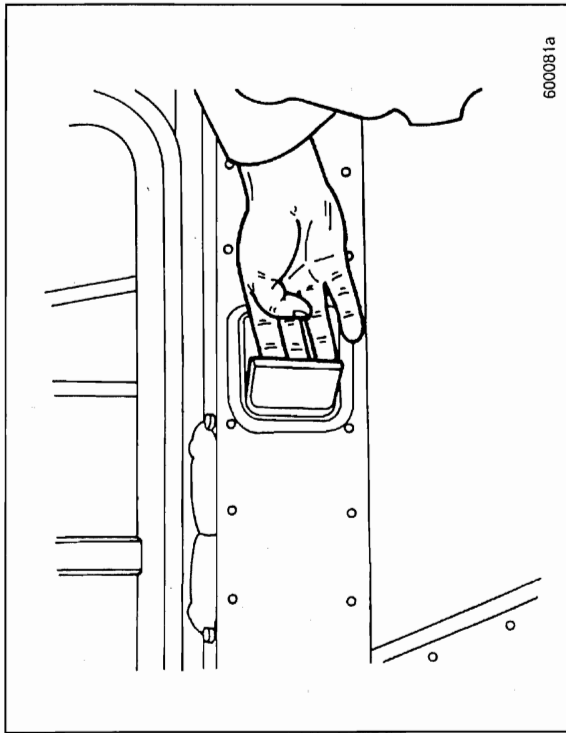

The inside door handles are of flush-mounted, paddle-type design. To open, put your fingers behind the handle and pull out while exerting some force on the door to open it.

#### Locking

To lock (with door open), press the door handle inward and shut the door.



**OPERATION**

**PTO Operating Procedures**

The following procedures apply to transmissions with a neutral switch and a transmission rear-case-mounted PTO only.

When engaging PTO:

1. Select LO-split using the splitter switch and select LO range using the range selector. The transmission **MUST** be in LO range and LO-split at all times during PTO operation.
2. Depress the clutch pedal to disengage the clutch.
3. Set parking brakes.
4. Move the main box gearshift lever to the **NEUTRAL** position.
5. Move the dash-mounted compound neutral control valve to the **ON** position, which moves the synchro clutch to a neutral position.
6. Engage the PTO.
7. Move the main box gearshift lever to the desired ratio.
8. Release the clutch pedal to engage the clutch.
9. Operate the PTO-driven load.

When disengaging the PTO:

1. Depress the clutch pedal to disengage the clutch.
2. Move the main box gearshift lever to **NEUTRAL**.
3. Disengage the PTO.
4. Move the dash-mounted compound neutral control valve to the **OFF** position, which moves the synchro clutch back to LO range.
5. Move the gearshift lever to the desired main gear box ratio.
6. Release the parking brakes.
7. Release the clutch pedal to engage the clutch.



**OPERATION**

MACK transmission rear-mounted PTO units fall into one of two categories (depending on how they operate).

**Intermittent Service** — The PTO unit is operated, under load, for less than seven minutes and then allowed to cool before it is operated again.

**Continuous Service** — The PTO unit is operated, under load, for seven minutes or more. Also, units operated for less than seven minutes and not allowed to cool down before operating again, should be considered in continuous service.

Rear-mounted PTO units operating under the continuous service guideline must not be run at more than 70% of the PTO output-rated torque/horsepower.

**V-MAC** — PTO operations controlled through V-MAC differ from vehicles not equipped with V-MAC. See TS725 (V-MAC) or TS780 (V-MAC II) for information regarding the programming of PTO.

**OPERATION****Engine****OPERATION****CAUTION**

Use a Mack-approved winterfront designed for the specific chassis only. The use of winterfronts or shutters for normal operating conditions above freezing requires caution to avoid high intake/exhaust temperatures. The restriction in air flow can cause higher exhaust temperature, power loss, excessive fan usage and a reduction in fuel economy.

**CAUTION**

A Mack-approved exhaust pyrometer must be installed and closely monitored while the engine is in operation when a winterfront is used. DO NOT exceed the maximum temperature listed on the decal. To reduce exhaust temperature, downshift or reduce engine power and open the winterfront.

**CAUTION**

Do not permit load to drive engine above governed speed. Operate in a gear low enough to allow engine to accelerate to (or maintain) governed RPM when applying throttle.

**WARNING**

Misuse or modification of a turbocharger can result in serious injury and property damage. In addition, extreme care must be taken to avoid foreign material induction, excessive exhaust temperatures and lack of lubrication.

**Model Designation**

The MACK engine unit symbol designation system is designed to provide total unit description identification through a combination of prefix letters, numbers, digits and suffix letters, as applicable.

**Prefix Letters and Numbers:**

- E = MACK turbocharged diesel engine
- M = Maxidyne engine (high torque rise)
- 7 = 728 cubic inch displacement
- 9 = 998 cubic inch displacement
- Digits: peak gross horsepower (BHP)

**NOTE**

E7 engines use the Jacobs compression release brake, or the Jacobs Stealth Retarding System™. With either system, the best braking performance is achieved in the 1800 to 2100 RPM range. For optimum retarding power, keep engine RPM as close to 2100 RPM as possible. For additional information, refer to the Jacobs driver's manual supplied with your chassis.

**OPERATION**

When slowing for a stop, leave clutch engaged as long as possible to use the braking effect of the engine. When forward speed has dropped to a little above idling speed, push clutch pedal in and brake to a complete stop.

**Parking Brake**

Spring-type parking brakes are standard on rear axles and bogies. The basic unit of a spring brake system is an air cylinder with heavy springs integrated with the service brake chamber. The spring brake chamber operates so that when there is no pressure in the spring brake section of the air chamber, the spring expands, causing a brake application. When air pressure is applied to the spring section of the air chamber, the heavy spring is compressed, releasing the brakes.

The spring brakes can be applied and released from the cab by using the hand-operated control valve. In the event of an air loss in both the primary and secondary air systems, pressure is automatically exhausted from the spring brake chambers, applying the brakes. The spring brakes will remain applied until enough pressure is available in the system to compress the heavy application springs.

**CAUTION**

*NEVER use the trailer parking brake system alone.  
Use the tractor-trailer parking brake system only.*

**OPERATION****Brakes****Air Brake System**

This truck has been built to meet or exceed all applicable federal standards and regulations.

**Brake Operation** — The air brake system consists of three main elements:

- The compressor, governor and reservoirs supply and store the air pressure.
- The brake application valve controls the brake application pressures.
- The brake chambers perform the work on the brake mechanism.

MACK vehicle design has incorporated into this chassis a dual braking system. It has two complete air circuits: a primary circuit for rear brakes and a secondary circuit for front brakes. Each circuit receives air from separate reservoirs. Although there are two air circuits, they operate as one brake system through the dual-circuit treadle valve. This provides the driver with easy, graduated control when applying and releasing the brakes.

The air pressure in the two air brake circuits is monitored by air pressure gauges on the instrument panel. (See the INSTRUMENT PANEL section for more information.) When air pressure drops below 65 ± 5 psi (448 ± 34 kPa) in either the primary or secondary air system at any time other than vehicle startup, pull to the side of the road and determine problem. If air pressure continues to drop below 40 ± 5 psi in BOTH systems, spring brakes will automatically apply. The Low Air Pressure warning indicator or buzzer will be activated if low air pressure occurs in either circuit.

**CAUTION**

*Avoid sudden stops. Constant, sudden stops may negatively affect the performance of braking and driving parts.*

**OPERATION****Good Driving Habits****Gross Vehicle Weight (GVW) Rating**

Do not overload your chassis. The gross vehicle weight ratings for a given model truck vary with operating conditions, tire size, wheel base, type of wheels, axles, suspension, frame length and overhang. For economy and safety, it is important to observe the GVW rating for your particular truck, which can be found on the Safety Certification Label.

**Observe Instruments**

Glance at instruments frequently. When problems develop, take prompt steps to correct them.

**Stopping the Engine**

After a hard run, allow engine to idle three minutes before shutdown in order to stabilize the temperature of all engine parts. Quick shutdowns can cause engine damage and prevent the turbocharger from being properly lubricated.

**Parking**

Use only the parking brake for parking. Do NOT use the hand control for rear service brakes or trailer brakes (if equipped) for parking. Check brake adjustment frequently to be sure the brakes will lock and hold vehicle when parked. Do NOT use the parking brake for braking vehicle when in motion, except in an emergency. When parking on a grade, use wheel chocks under the rear wheels or turn front wheels to the curb. Do NOT leave diesel engine vehicles in gear; if vehicle should move, the engine may start by heat of compression.

**General Observation**

Make it a habit at stops to walk around your truck looking for fuel, oil and coolant leaks. Also check condition of tires, wheel nuts, springs and lights. Stop trouble before it stops you!

**OPERATION****Anti-Lock Brakes (If Equipped)****Installation of Electrical Equipment on Vehicles Equipped with Anti-Lock Brake System (ABS)**

Connecting electrically powered or electrically controlled equipment to the vehicle may cause interference with the proper operation of other vehicle components. This interference may depend on the operating frequency and the degree to which transient signals are coupled into the vehicle system.

Every user and installer of electrical equipment has the obligation to ensure the proper operation of all electrical systems on the vehicle with respect to conducted or radiated signals by his installation.

Specific attention is directed to the anti-lock brake control system. A vehicle checkout procedure should include operating any added circuitry under the following test conditions:

- Engine running and brake air system pressure in operating range
- Vehicle stationary
- Depress and hold brake pedal in full application pressure mode
- Operate added equipment in all starting, running and shutdown conditions. Listen for any air exhausting from anti-wheel-lock controllers. This indicates an interference condition which must be corrected before the vehicle is released for highway use.

**Operating an ABS-Equipped Vehicle**

- Apply the brakes as normal. If the anti-lock brake system begins to function, maintain brake pressure. DO NOT release the brakes.
- Avoid rapidly pumping the brakes. The anti-lock brake system automatically applies and releases the brakes up to five times per second.
- When towing a trailer(s), especially if only the tractor is equipped with anti-lock brakes, watch the trailer(s) through the mirrors. Adjust brake application pressure as necessary to keep the combination in a straight line. Make sure the trailer(s) follows the tractor properly.

### OPERATION



#### Cold Weather Starting Tips

#### NOTE

Before attempting to start the engine during cold weather, actuate the Engine Stop Control (if so equipped) several times to ensure that the injection pump control rack is free. Condensation in the fuel could cause the control rack to freeze up after extended shutdown in cold weather.

- Save your batteries. Do not overtax batteries and starting motor by cranking for more than 30 seconds without interruption. Allow about two minutes between attempts at starting the truck. This permits starter to cool and batteries to re-energize.
- Use the correct grade of oil in your crankcase for the prevailing winter temperature.
- Water/moisture can accumulate in the fuel system. Water accumulation can freeze in fuel tank, fuel lines and filter. This can be avoided by regularly draining the tanks and filters.

#### WARNING

**Under NO circumstances should gasoline, alcohol, used oil or additives with metallic particles be added to the fuel.**

- Diesel fuel has some bad habits in cold weather. It can gel and clog filters and small passages. When gelling occurs, mix a small percentage of No. 1D fuel (kerosene) with No. 2D (diesel) fuel. Adding kerosene is NOT recommended for general use since there will be a sacrifice in both performance and fuel economy. Refer to the MAINTENANCE AND LUBRICATION manual, TS494, for additional cold weather operating information.

### OPERATION



#### STARTING YOUR VEHICLE

##### General Information

Before you put the key in the ignition switch, set the parking (spring) brake, disengage the clutch (if equipped) and put the transmission in NEUTRAL. Push the Engine Stop Control all the way in (if equipped).

#### CAUTION

*Do not engage the starting motor too soon after an incomplete start of the engine, or the starter may be damaged. Wait at least five seconds before attempting to restart the engine.*

#### CAUTION

*Do not rev the engine at start-up. Turbocharger damage may result. Lubricants need time to establish a film between moving parts.*

#### CAUTION

*If the engine does not start immediately, limit cranking periods to 30 seconds to avoid overheating and damaging the starter.*





### OPERATION

#### Air Starter or Push Button (If Equipped)

#### NOTE

Build up air pressure to a maximum (120 lbs/827 kPa) before shutting down and parking for the night.

#### CAUTION

*Idling engine unnecessarily for long periods of time wastes fuel and fouls injection nozzles. Unburned fuel causes carbon formation and oil dilution. NEVER race an engine during warm-up.*

Put the key in the ignition switch. Turn the key clockwise to the first "click" (about two o'clock position) to activate the instruments. Push starter button in and release as soon as engine starts. Keep clutch (if equipped) disengaged until engine runs smoothly. When oil pressure and air pressure approach normal operating ranges, you may put the vehicle into operation.



### OPERATION

#### Engine Block Heater

An engine block heater works by heating the coolant surrounding the combustion chambers. Engine heaters are recommended to help combat the extreme demands of cold weather operating conditions. The engine heater can be plugged in overnight when the temperature drops. Location of the engine heater power receptacle varies according to vehicle design.

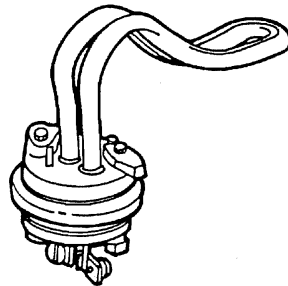

200798a

#### Engine Heater Benefits

- Eliminates cold weather starting problems.
- Increases engine life significantly by keeping the engine warm and avoiding costly, excessive idling.
- Prevents external water leaks caused by excessive cold.
- Allows the cab to heat more quickly.
- Reduces the temperature at which ether is required.
- Engine heaters may be activated as soon as the engine is stopped.

**OPERATION****E7 Non V-MAC Engines**

If your chassis is equipped with a mechanically governed E7 (non V-MAC) engine, use the following procedure:

**Normal Temperatures**

1. Do NOT depress the accelerator.
2. Crank the engine.
3. After the engine has started, set the hand throttle to maintain an engine speed of 1200 RPM.
4. Allow the engine to idle at 1200 RPM and reach normal operating temperature BEFORE moving the vehicle.

If the engine is difficult to start, use the following procedure:

1. With the key switch in the OFF position, fully depress and hold the accelerator pedal to the floor.
2. If equipped with an Engine Stop Control, pull to the OFF position, then return to the run position.
3. Crank the engine.
4. Release the accelerator pedal as soon as the engine starts.

**Cold Temperatures**

1. Fully depress and hold the accelerator pedal to the floor.
2. Push the Charge Air Cooler Bypass switch (if equipped) to the ON position. A dash light will illuminate when the bypass is activated.

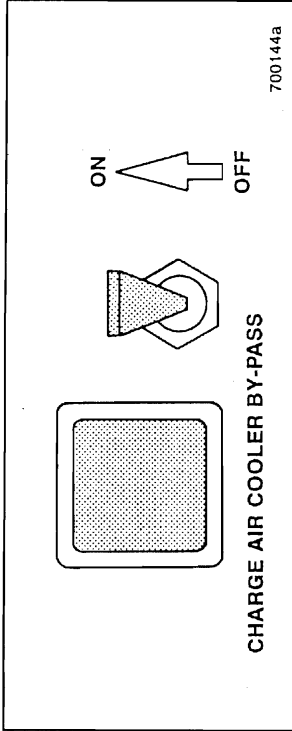
**OPERATION**

3. Crank the engine.
4. Release the accelerator pedal as soon as the engine starts.
5. Set the hand throttle to maintain an engine speed of 1200 RPM.
6. Allow the engine to idle at 1200 RPM and reach normal operating temperature BEFORE moving the vehicle.
7. Move the Charge Air Cooler Bypass switch (if equipped) to the OFF position when the coolant temperature has reached 125°F (52°C).

**CAUTION**

Operating the chassis with the Charge Air Cooler Bypass switch (if equipped) in the ON position may cause severe engine damage.

**CAUTION**

Do NOT use the Charge Air Cooler Bypass switch (if equipped) during warm temperatures or if the engine is already warm.

**OPERATION****Engine Warm-Up**

Engine damage can occur if the engine is not warmed up to a minimum operating temperature of 170°F (77°C) before putting the chassis into full operation.

Heavy-duty diesel engines are designed to operate at optimum efficiency when they are running loaded at (or very near) normal operating temperature where efficient combustion takes place. When the engine is operated unloaded, lightly loaded (stop and go operations, PTO operations, or periods of extended engine idling) or in cold weather conditions, normal operating temperature may not be achieved or maintained. As a result, carbon and/or varnish build-up will occur and lubricating oil will become contaminated with combustion byproducts.

Cold weather operations place added demands on a diesel engine. When operating in cold climates, particularly in stop-and-go operations, PTO operations or periods of extended engine idling, minimum operating temperature must be maintained to prevent engine damage resulting from valve varnishing and carbon build-up. Many accessories, from winterfronts to belly tarps, are available to best equip your truck for cold weather operations. Refer to the **MAINTENANCE AND LUBRICATION** manual, TS494, supplied with your truck for additional information concerning cold weather accessories.

**Engine Idling**

Idling the engine unnecessarily for long periods of time wastes fuel, fouls injector nozzles and can lead to valve carbon and varnish deposits. Unburned fuel causes carbon formation and oil dilution. Shut engine down when prolonged loading or unloading of cargo is required. When starting a cold engine, or if the vehicle has been parked and the engine coolant has fallen well below normal operating temperature, a fast idle speed of approximately 1200 RPM should be maintained to help the engine warm up more quickly.

**OPERATION****E7 V-MAC Engines**

If your chassis is equipped with an electronically governed E7 (V-MAC) engine, use the following procedure:

**Normal Temperatures**

1. Do NOT depress the accelerator. The pedal must be left in the idle position.
2. Crank the engine.
3. After the engine has started, set the hand throttle to maintain an engine speed of 1200 RPM.
4. Allow the engine to idle at 1200 RPM and reach normal operating temperature **BEFORE** moving the vehicle.

**Cold Temperatures**

1. Fully depress and hold the accelerator pedal to the floor.
2. Crank the engine.
3. Release the accelerator pedal as soon as the engine starts.
4. Set the Variable Speed Control (VSC) (if equipped) to maintain an engine speed of 1200 RPM.
5. Allow the engine to idle at 1200 RPM and reach normal operating temperature **BEFORE** moving the vehicle.

**OPERATION****Engine Shutdown System (If Equipped)**

The engine may be protected by a shutdown system that prevents engine failure when a condition such as loss of oil pressure, loss of coolant or engine overheating occurs. If the system detects a condition that will initiate engine shutdown, a warning indicator light will illuminate to alert the driver before the engine actually shuts down. Should shutdown occur, the system can be overridden so the vehicle can be moved to a location where it will not pose a hazard.

**Check Engine Warning Indicator** — During normal operating conditions, the Check Engine warning indicator should illuminate as soon as the key switch is turned on. After the engine is started, it will remain illuminated until engine oil pressure reaches normal idling range. During shutdown, if the system detects a condition that could lead to engine failure, the Check Engine warning indicator illuminates 30 to 45 seconds prior to engine shutdown.

**Lengard Shutdown System**

**Shutdown Override Button (If Equipped)** — During normal operation, to ensure adequate fuel delivery when starting the engine (whether starting a hot or a cold engine), the following starting procedures are recommended (Lengard system only):

1. Depress and hold the Shutdown Override button.
2. Crank the engine.
3. Continue depressing the Shutdown Override button after the engine is started and the Check Engine warning indicator is still illuminated.
4. Release the Shutdown Override button when the Check Engine warning indicator deactivates.

Refer to the **STARTING YOUR VEHICLE** section for complete engine starting procedures.

**OPERATION****Engine Shutdown**

After a hard run, allow the engine to idle approximately three minutes before shutdown. This provides the temperature stabilization of all engine parts and allows the turbocharger RPM to slow gradually. Quick shutdowns can result in mechanical problems for the engine and/or turbocharger.

**CAUTION**

*Operating the engine below normal operating temperature for extended periods of time will allow varnish/carbon deposits to build on the valve stems and guides. Varnish deposits will cause the valves to stick in the guides after the engine has been shut down, and could result in push rod damage when the engine is restarted. If the engine has been operated below normal operating temperature for an extended period of time, and the odor of raw diesel fuel can be detected or unburned fuel can be seen at the exhaust stack, it is recommended that the engine be operated under load until normal operating temperature is achieved before shutting down.*

On chassis equipped with an air starter, make sure that the air pressure gauge reads a maximum of 120 psi before shutting down and parking for the night. This will ensure sufficient air pressure for restarting the engine.



### OPERATION

#### MOVING YOUR VEHICLE

##### General Information

##### Braking

Avoid sudden stops. Constantly making such stops may have a negative effect on the performance of braking and driving parts. When slowing, leave clutch (if equipped) engaged as long as possible to use the braking effect of the engine.

#### CAUTION

*When using the braking effect of the engine, final gear selection is critical. If gear selection is too high the vehicle will buck, which could cause loss of control.*

E7 engines use the Jacobs compression release engine brake, or the Jacobs Stealth Retarding System™. With either system, the best braking performance is achieved in the 1800 to 2100 RPM range. For optimum retarding power, keep engine RPM as close to 2100 RPM as possible. For additional information, refer to the Jacobs driver's manual supplied with your chassis.

##### Shifting

Operate in a gear low enough to allow engine to accelerate to, or maintain, governed RPM when applying full throttle. Allowing the engine to lug causes excessive strain on engine which could damage pistons, rings, cylinder walls, or bearings. However, you should not overspeed the engine either.

#### CAUTION

*Do not permit a load to drive the engine above governed speed. Use lower gears when descending steep grades, and watch the tachometer. Over-speeding will cause severe drivetrain damage and eventually destroy the engine.*



### OPERATION

**During Shutdown** — If the shutdown system activates, use the following procedures to move the vehicle to a location where it can be parked safely:

1. Push and hold the Shutdown Override button (if equipped).
2. Start the engine.
3. Continue depressing the Shutdown Override button while moving the vehicle to the nearest area where the vehicle can be parked safely.

##### Kysor Shutdown Systems

There are no special starting instructions for the Kysor shutdown system. To override the engine shutdown system so the vehicle can be moved to safety, simply restart the engine in the normal manner. The engine will run for 30 seconds and then shut down again.

#### CAUTION

*Continuously overriding the shutdown system for an extended period will cause severe engine damage.*

# REED

CONCRETE PLACING  
EQUIPMENT

## MR SERIES MACK TRUCK

VENDR

FIGURE 01  
PAGE 42



### OPERATION

#### Clutch (If Equipped)

To avoid shock damage, release the clutch pedal smoothly without shock-loading the driveline, especially on grades while carrying heavy loads. Do not ride the clutch pedal. Premature wear of clutch facing and release bearing may result.

#### CAUTION

*Always use the lowest drive gear combination to start vehicle moving to avoid premature clutch failure.*

#### General Instructions

1. To move the vehicle, begin by starting the engine and waiting until it reaches its operating range.
2. Disengage the clutch (if equipped) by pushing the pedal to the floor.
3. Shift transmission into first or LO gear (see Transmission Shifting Instructions for how to shift your particular transmission and in what gear to start).
4. Release the parking brake.

#### CAUTION

*If the Spring Brake Warning indicator is on, do NOT attempt to move the vehicle because driveline damage may result.*



### OPERATION

#### ⚠ DANGER

*Select the proper gear ratio BEFORE descending a grade to avoid a runaway vehicle and to stay within safe and legal speed limits. Do NOT coast down hills. Gear ratios should be selected to allow engine operation between peak torque and rated speed.*

#### CAUTION

*Running the engine at an RPM that is too low for the load or grade of the road can cause damage to the drivetrain.*

Shifting at the proper time will save both fuel and unnecessary repair bills, but remember that once your engine falls below the peak torque, both the torque and horsepower drop off very rapidly. Before this happens, downshift to the next lower gear.

On vehicles with transmissions having extreme reduction gearing coupled with high rear-axle loads, a torque-limiting device will be used. This device limits the amount of fuel that can be delivered to the engine by the injection pump and prevents overloading of the drivetrain components while in extreme reduction gears.

Use the same gear going downhill as you would going uphill. This will save your brakes and prevent damage to the engine from over-speeding.

#### Engine Temperature

Before entering high-speed traffic conditions, allow the engine to reach normal operating temperature. Normal operating range may be between 170°F and 225°F (77°C and 107°C) depending on weather and road conditions.



**OPERATION**

**Clutch Brake Operation (If Equipped)**

The clutch brake is designed to stop the rotation of the transmission input shaft while the truck is standing still, to make shifting into first or reverse gears easier.

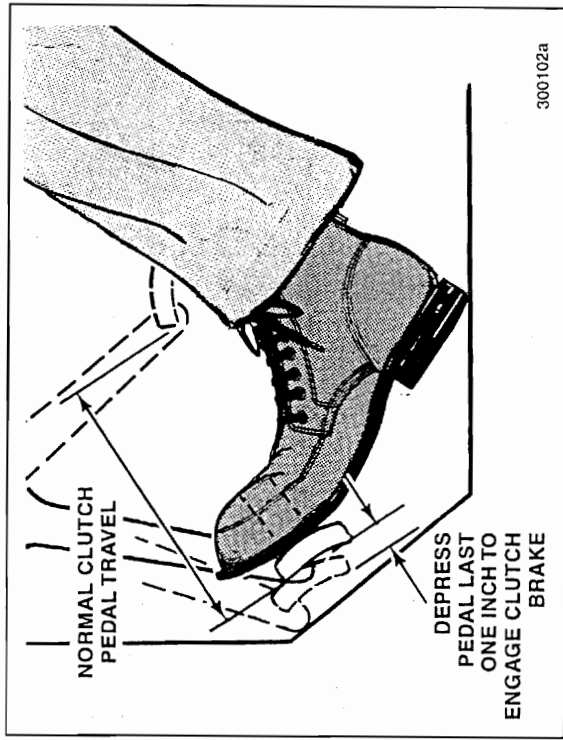

With the vehicle standing still, push in the clutch pedal. Apply the clutch brake by pushing the clutch pedal all the way to the floor (the clutch brake is applied when the clutch pedal is fully depressed, the last one inch of travel past normal pedal travel).

**NOTE**

When the clutch is engaged, a slight but definite resistance to clutch pedal downward travel will be felt in the last one inch.



**OPERATION**

- Engage clutch (if equipped) smoothly by releasing the clutch pedal. At the same time, apply the accelerator enough for the engine to move the load.

**CAUTION**

*Never allow your foot to ride the clutch pedal when clutch is engaged. This will cause premature failure and short clutch facing life.*

- As vehicle gains speed, continue shifting until transmission is in the highest gear possible with engine in operating range.

**NOTE**

Engine must be warmed up to operating temperature before attempting to move in either REVERSE or LO-LO range when the vehicle is equipped with a torque-limiting device.

### OPERATION



#### Transmission Shifting Instructions

#### CAUTION

Maximum safe oil temperature is 235°F (113°C) for manual transmissions. Continued operation with oil above this temperature will cause rapid deterioration of the oil's lubricating properties and is NOT recommended.

#### CAUTION

The vehicle must be completely stopped before attempting to shift from REVERSE to any forward speed, or vice versa, to avoid transmission damage.

#### T2070-T2070C-T2070F TRANSMISSION RATIOS

Gear (Main Box)	Ratios	
	LO	HI
1	14.16	5.24
2	8.25	3.05
3	(4.67)	1.73
4	(2.70)	1.00
5	(1.62)	0.60
5 (T2070C)	(1.81)	0.67
Reverse	14.53	5.38

( ) The ratios in parentheses are not practical to use.

300161a

### OPERATION



Shift the transmission into first or reverse gear, engage the clutch and accelerate. The clutch brake is only to be used when the vehicle is stopped and being shifted into first or reverse gears. It is not designed to be used as an upshifting aid.

#### CAUTION

Clutch brake damage may result if used while the vehicle is in motion. The clutch brake must NOT be used when making a downshift or an upshift.

#### Double-Clutching

As with all nonsynchronized transmissions, double-clutching is necessary on downshifts as well as upshifts. It is advisable to use the torque-limiting clutch brake to engage first and REVERSE gears and to double-clutch for gear ratio changes.

Double-clutching is a way to bring the speed of transmission gears into synchronization so that the shift can be made without clash. The engine is used to speed up the countershaft for a downshift and to slow it down for an upshift.

1. Depress clutch pedal and shift to NEUTRAL.
2. Let up clutch pedal and accelerate engine (when making downshift) or allow engine to slow down (upshift) until engine speed approximately corresponds to road speed of gear to be selected.
3. Depress clutch pedal and complete shift to desired gear. Release the clutch pedal.



**OPERATION**



**MACK T2070-T2070C-T2070F**

The T2070-T2070C-T2070F are nonsynchronized transmissions. These transmissions feature a LO and HI auxiliary compound section controlled by an air-shift range selector located on the shift lever. The LO range provides two low ratios. In HI range there are five forward gears that can be shifted in the standard manner, but remember to double-clutch whether moving up or down through the gears. For normal highway usage, start in HI range, first gear and shift through second, third, fourth, and fifth. The two gears in LO range are designed for off-highway use and in slow-moving applications (curb pouring, material spreading, heavy load/steep grade operation). REVERSE can be used in LO or HI range.

**Upshift** — Begin in first gear, LO range (commonly called LO-LO as shown on the shift pattern diagram). Double-clutch and upshift to second gear, LO range (called LO) in the normal manner. When ready to upshift again, depress the clutch pedal and release the accelerator pedal. Move the shift lever to NEUTRAL, then flip the air-shift range selector to HI range, double-clutch and move the shift lever back to first gear. This is first gear HI range, which provides the next higher ratio. Release the clutch pedal and apply the accelerator to reach the top of the operating range. Shift through second, third, fourth, and fifth (HI range), being sure to double-clutch from one gear to the next.

**Downshift** — Downshift in reverse order from fifth through first gear (HI range), double-clutching through each gear. The next downshift will be to second gear, LO range (called LO). Proceed to depress the clutch pedal and release the accelerator pedal. Move the shift lever to NEUTRAL, then flip the air-shift range selector to LO range, double-clutch and move the shift lever to second gear. This is second gear, LO range, which provides the next lower ratio. When ready for the lowest ratio available (called LO-LO), double-clutch and downshift to first gear, LO range.

**OPERATION**

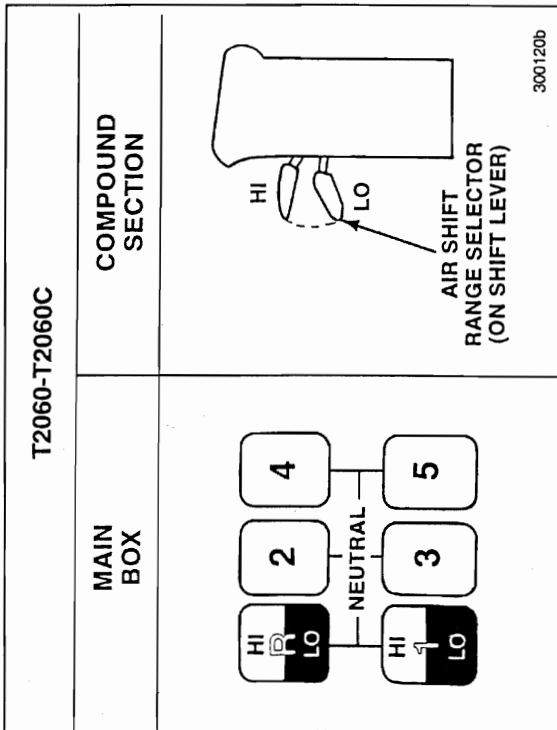

**T2060-T2060C TRANSMISSION RATIOS**

Gear (Main Box)	Ratios	
	LO	HI
1	9.02	5.24
2	(5.25)	3.05
3	(2.98)	1.73
4	(1.72)	1.00
5 (T2060)	(1.03)	0.60
5 (T2060C)	(1.16)	0.67
Reverse	9.25	5.38

( ) The ratios in parentheses are not practical to use.

300121b

# REED

CONCRETE PLACING  
EQUIPMENT

## MR SERIES MACK TRUCK

VENDR

FIGURE 01  
PAGE 46

### OPERATION



#### Axles

#### Rear Axle

Mack Trucks, Inc. provides axle housings in three capacity classifications. They are medium duty, heavy duty and extra-heavy duty. To deliver the appropriate amount of torque to the driving wheels, Mack Trucks, Inc. offers single-reduction and dual-reduction carriers in a large variety of ratios for single axle applications. When required, a large variety of four-wheel-drive, two-axle bogies are also available with top-mounted, dual-reduction carriers for straight line through drive. The bogie carriers are also available in a large number of ratios.

All four-wheel-drive bogie tandem carriers are available with the MACK inter-axle power divider third differential, with or without a driver-controlled lockout.

MACK rear axles are designed so the entire load is carried by the axle housing through the wheel bearings mounted on the housing spindle. The rear axle shafts can be either free-splined, both ends, or integral flange type. Both types of axle shafts may be removed without removing or disturbing the rear wheels.

To avoid excessive tire wear, good maintenance must be practiced in the matching of tires on bogies without a compensating inter-axle power divider.

### CAUTION

Maximum safe oil temperature is 235° F (113° C).  
Continued operation with oil above this temperature will cause rapid deterioration of the oil's lubricating properties and is NOT recommended.

### OPERATION



### CAUTION

Do not overspeed the engine when downshifting the transmission. Damage to the drivetrain components can result. Do NOT preselect the air-shift range selector. Shift the auxiliary compound section only with the clutch pedal depressed and/or the shift lever in NEUTRAL. To avoid transmission damage, do NOT change range while moving in reverse gear.

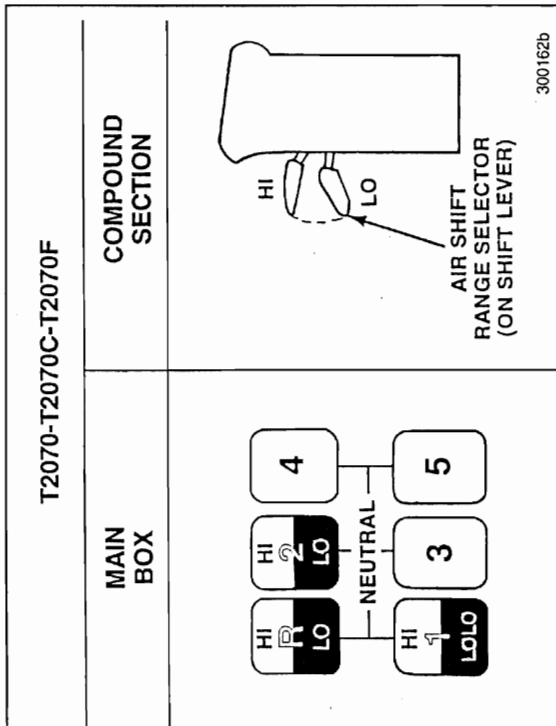

### OPERATION



### OPERATION



#### Two-Speed Rear Axle

The dual-reduction rear axle carrier employs selective fast and slow gear reductions. Electric shift (button on the transmission shifter lever) provides either fast or slow ratio by selecting these gearsets. The transmission is shifted in the usual manner and the two-speed axle is shifted in the usual manner. The two-speed axle is shifted as follows:

**Split Shifting** — To shift to higher transmission gear and LO axle speed at the same time:

1. Shift transmission to higher gear in the usual way.
2. Push the axle shifter button down just before re-engaging the clutch.
3. Re-engage clutch and depress the accelerator to maintain road speed.

To shift to lower transmission gear and HI axle speed at the same time:

1. Hold accelerator down and pull axle shifter up.
2. Shift transmission to lower gear in the usual way, then depress accelerator to maintain road speed.

### CAUTION

Always keep accelerator down when shifter button is moved, except when split shifting to LO axle speed. Vehicle must be brought to a full stop before shifting from forward to REVERSE, and vice versa.

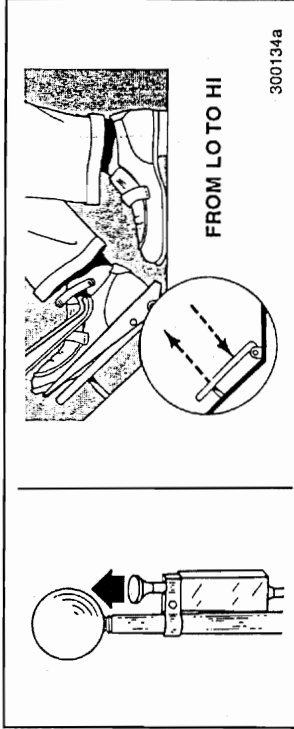

**To shift from LO to HI speed** — Hold accelerator down and pull axle shifter button up. Ride with accelerator down until you want to complete shift. Release accelerator, pause until shift is completed, then depress accelerator to maintain road speed.

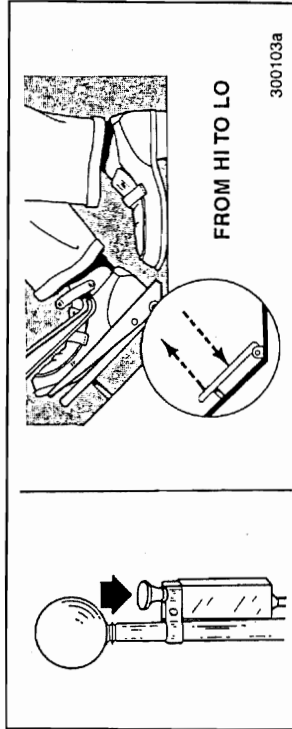

**To shift from HI to LO speed** — Push axle shifter button down and hold accelerator down until you want to shift. Disengage and re-engage clutch as quickly as possible while holding accelerator down, or release and depress accelerator as quickly as possible without declutching.



### OPERATION

Decouple the engine (if equipped with an automatic transmission, shift to NEUTRAL) and move the lockout switch to the engaged position. Re-engage clutch and drive through the slippery area.

#### NOTE

An electric buzzer in the cab sounds continuously as long as the lockout is engaged. This is to remind the driver to release the lock as soon as normal traction is regained.

When driving conditions permit returning to normal, unlock power-divider drive, move the lockout switch back to the OUT (disengaged) position, and let up momentarily on the accelerator pedal to powershift out of locked position. Then drive as usual.

#### CAUTION

To avoid clash at the lockout sliding clutch and outer cam, under NO circumstances should the air-shift mechanism be activated while the drive wheels are actually slipping or spinning.

### OPERATION



#### Inter-Axle Power Divider (If Equipped)

A driver-controlled, air-shifted lockout is available so the MACK power divider can be rendered inoperative for short periods of poor traction, and then unlocked when normal traction returns. When the MACK sliding clutch lockout is engaged with mating teeth of the outer cam, both axles are locked together in positive through-drive for maximum traction with no differential action taking place between axles.

Normally, the driver-controlled, inter-axle power divider lockout control switch is in the OUT or unlocked position. On rare occasions, it is necessary to provide positive through-drive to both bogie axles for poor traction situations.

#### CAUTION

Stop the vehicle before actuating the air-shift range selector.

#### NOTE

The lockout should NOT be used on dry, hard surfaces.

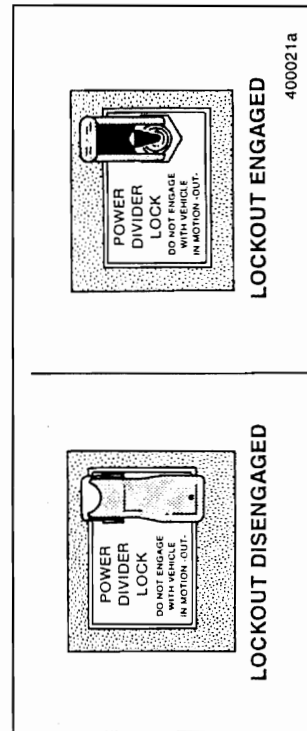

# REED

CONCRETE PLACING  
EQUIPMENT

## MR SERIES MACK TRUCK

VENDR

FIGURE 01  
PAGE 49



### MAINTENANCE AND LUBRICATION

#### TOWING

There is one center-mounted tow pin located in the front bumper. The device meets the requirements set forth by The Maintenance Council (TMC) of the American Trucking Association. The tow pin may be used for towing a disabled vehicle from the immediate location.

If it is necessary to remove the tow pin, remove the retainer clip first. Once the retainer clip is pulled, the tow pin can be lifted out of the bumper hole.

#### CAUTION

*Do NOT lift and tow vehicle by tow pins, hooks, eyes, etc. If mired in heavy mud, snow, etc., use a suitable sling-type towing arrangement to move the truck.*

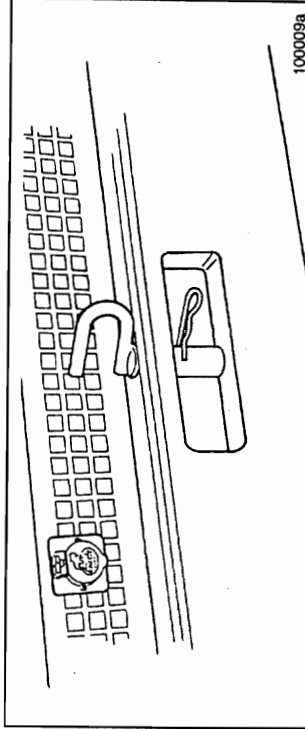

### MAINTENANCE AND LUBRICATION

#### MAINTENANCE INTRODUCTION

Preventive maintenance is vital to the life of your new MR. This section of the Operator's Handbook covers items of importance concerning the proper care of your new truck. A well-run maintenance and lubrication program is the best way of ensuring a long and productive life for your truck, as well as increased profitability and reduced maintenance costs for your business.

The operator plays an important role in the proper care of this equipment. By performing daily checks and observing the equipment while it is in operation, minor defects can be caught and corrected before they become major problems. Make sure any problems are corrected before putting the equipment into operation.

The service manager at your Mack Sales, Parts and Service Center knows your truck the best. Your satisfaction is his main concern. If you have any questions concerning the proper care, maintenance and lubrication of your MR, or if you need help in developing a preventive maintenance program, he will be glad to help.

#### NOTE

This handbook contains some maintenance information. Refer to TS494 for complete maintenance and lubrication procedures.

**MAINTENANCE AND LUBRICATION****ENGINE****Oil Level Check**

As the operator of this vehicle, it is important for you to perform the daily inspections necessary to keep your truck in good shape. Maintaining the proper oil level in your engine crankcase cannot be overemphasized.

Before checking the oil, remember these important points:

- Measurement of the oil level must be taken on level ground.
- If the engine has been running, allow about 15 minutes after shutdown for oil to drain down to the oil pan.
- The level must be close to the FULL line (at least between the ADD and FULL lines) on the dipstick, but must NOT exceed the FULL line (refer to illustration below).

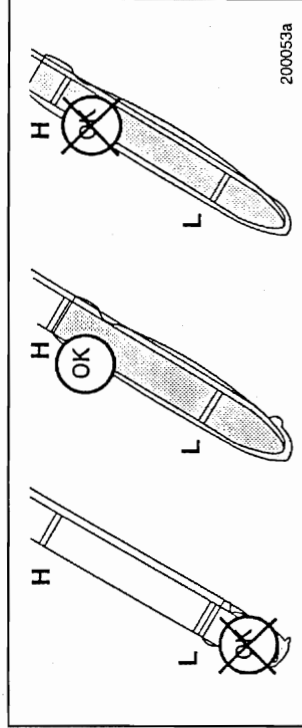
**MAINTENANCE AND LUBRICATION****NOTE**

Use of tow pins, hooks, eyes, etc., is NOT intended for long-term wrecker pull of disabled vehicles.

**CAUTION**

*Failure to disconnect the driveline before towing or pushing the vehicle can cause serious transmission damage.*

Before towing or pushing the vehicle, the driveline should be disconnected or the drive wheels should be lifted off the ground.



**MAINTENANCE AND LUBRICATION**

**COOLING SYSTEM**

The cooling system is a pressurized system. The coolant is circulated by a centrifugal pump. It is a typical system in most respects, but there are a few things to keep in mind when checking or working on the cooling system.

**WARNING**

Avoid injury when checking coolant in a hot engine. Wait for the engine to cool prior to checking the level, whenever possible.

**Winterfronts**

A MACK-approved winterfront, although not recommended for normal operation, may be used during cold weather to aid the engine in reaching and maintaining engine coolant temperatures within the normal operating range.

**CAUTION**

Use only a MACK-approved winterfront designed for the specific chassis. Restricted air flow through the charge air cooler can cause higher exhaust temperatures, power loss, excessive fan usage, reduced fuel economy and possible engine damage. The use of any other type of device, such as a radiator cover, cardboard or similar material, is not approved by Mack Trucks, Inc.

**NOTE**

The minimum operating temperature is 170°F (77°C).



**MAINTENANCE AND LUBRICATION**

When a winterfront is installed, a MACK-approved exhaust pyrometer must also be installed and closely monitored while the engine is in operation.

**CAUTION**

DO NOT exceed the maximum exhaust temperature listed on the pyrometer decal. To reduce exhaust temperature, open the winterfront, downshift or reduce engine power.

Maximum Ambient Air Temperature			
	Above 60°F (15.5° C)	60°F (15.5°C)	40°F (4.40°C)
MACK-Approved Winterfront	Not Recommended	Available*	Recommended
MACK-Approved Belly Tarp	Not Recommended	Not Recommended	Available*

\* Make sure that engine oil, coolant, transmission and pyrometer temperatures remain in normal operating range.

600273a

**CAUTION**

Winter treatments are NOT RECOMMENDED for vehicles which only operate intermittently in cold climates.

**CAUTION**

Never operate a viscous fan with a closed or partially closed winterfront.



### MAINTENANCE AND LUBRICATION

#### Draining

Whenever repairs are to be made which would require disconnection of coolant hoses, etc., the cooling system should be completely drained. Carefully remove the filler cap and open all coolant drain cocks.

#### Protecting Coolant System

#### CAUTION

*The concentration of ethylene glycol or propylene glycol in the cooling system must be checked with a refractometer prior to traveling or operating in areas where subfreezing temperatures may be encountered. When adding antifreeze to the system, run the engine for 20 minutes before checking with a hydrometer.*

#### NOTE

Your chassis is currently supplied from the factory with engine coolant protection to  $-10^{\circ}\text{F}$  ( $-23^{\circ}\text{C}$ ). Optional coolant protection to  $-40^{\circ}\text{F}$  ( $-40^{\circ}\text{C}$ ) is also available.

Ethylene glycol or propylene glycol-based antifreezes are both approved for all MACK engines. All ethylene glycol and propylene glycol coolants must be low-silicate antifreezes which meet ASTM4985 test (GM6038M SPEC) criteria. These antifreezes are sometimes referred to as heavy-duty diesel coolants. Passenger car coolants do NOT meet this specification.

Be sure to maintain the required level of antifreeze protection for anticipated winter temperatures in your area of operation. A 40% to 60% concentration of antifreeze is required for E7 and E9 engines, regardless of application, geographic location or ambient air temperature.



### MAINTENANCE AND LUBRICATION

#### ON/OFF FAN CLUTCH

An ON/OFF fan clutch can help prevent excessive cooling during extremely cold weather operations. Whereas viscous fans often rotate continuously during cold weather, an ON/OFF fan clutch keeps the fan in the OFF position, thus reducing unnecessary air movement and helping to maintain adequate engine operating temperatures.

#### COOLANT LEVEL CHECK

#### WARNING

Turn the radiator cap counterclockwise to the first stop but do NOT depress. After the pressure has completely dissipated, press the cap downward and continue turning to remove.

The MR model chassis has an expansion tank located on the left-hand side of the chassis, mounted on the air cleaner assembly support bracket. Coolant should be visible in the sight glass located on the side of the tank.

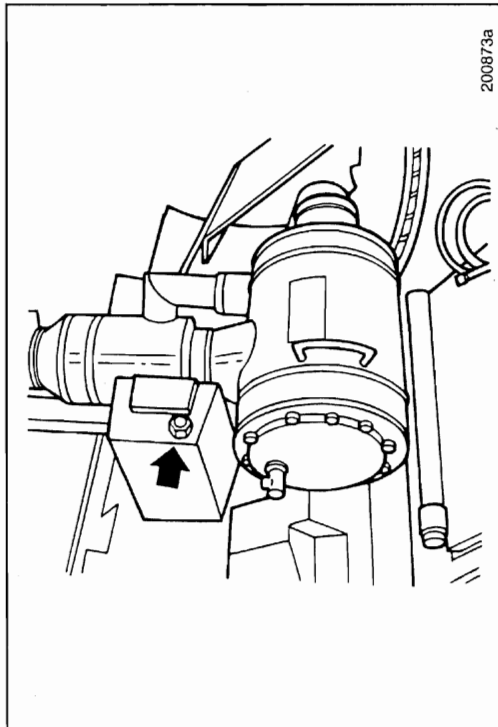

200873a



**MR SERIES MACK TRUCK****MAINTENANCE AND LUBRICATION****CAUTION**

Do NOT exceed a 60% concentration of antifreeze to water. A higher percentage of antifreeze will not increase protection. Concentrations over 60% adversely affect freeze protection and heat transfer rates.

**NOTE**

Propylene glycol should be checked with a refractometer.

**NOTE**

ALWAYS mix the water/antifreeze solution before pouring it into the cooling system.

**NOTE**

Piping arrangement may cause capacity variation depending on the type of cooling system and optional external cooling devices which may be attached. Therefore, it is difficult to tell exactly how much coolant it will take to fill any one particular system. As a general rule, fill to one inch below the bottom of the radiator filler neck.

**CAUTION**

Do NOT use coolant solutions which contain anti-leak additives in trucks equipped with coolant filters or conditioners.

**CAUTION**

Do NOT use soluble oil-type coolants in any MACK cooling system.

**Refilling**

Close all drain cocks and fill with the proper coolant mixture. Run engine with the radiator cap off until operating temperature is reached and the thermostat opens. Recheck level and add coolant, if required. Run the engine long enough to be sure the system is free of air and has the correct amount of coolant.

**Cooling System Maintenance**

The cooling system must be maintained by performing regularly scheduled maintenance as outlined in the MAINTENANCE AND LUBRICATION manual, TS494. Cold weather operations, however, place added demands on the cooling system. Prevent potential cold weather problems by performing a quick check of the cooling system as outlined below:

- Make a general check for cooling system leaks.
- Inspect hoses and clamps for leaks and condition. Tighten hose clamps to specifications (as required).
- Check coolant level. Add fresh coolant (in specified concentration) as necessary.
- Check and record degree of antifreeze concentration. Add antifreeze as necessary to obtain required protection level.



### MAINTENANCE AND LUBRICATION

#### Tires

#### **⚠ DANGER**

Tires used on multipiece rims must be assembled and inflated only by experienced, qualified personnel. Tires must be inflated in a safety cage whenever possible. If, however, a safety cage is not available, use a portable lock-ring guard. The tire must be deflated prior to removal of the tire-and-rim assembly from the vehicle. Remove the valve core to ensure complete deflation.

#### **⚠ DANGER**

NEVER position your body in front of the rim during inflation.

#### Inflation Pressure

In order to ensure maximum mileage and overall performance from your tires, it is essential that they operate at the correct inflation pressure for the load carried. Inflation pressure should be checked daily while the tires are cold. Always use an accurate tire pressure gauge. NEVER bleed air from a hot tire, as it will then be underinflated. Refer to the MAINTENANCE AND LUBRICATION manual, TS494 for a complete listing of tire inflation pressures, and for additional information concerning tire care.

#### **⚠ WARNING**

UNDER NO CIRCUMSTANCES should you drive on underinflated or overloaded tires. A tire in this condition builds up excessive heat which can result in sudden tire destruction, property damage and personal injury.



### MAINTENANCE AND LUBRICATION

#### WHEELS

#### Wheel Inspection

Look at wheels and cap nuts. Inspect them for evidence of cap nut looseness. Rust streaks from the cap nut ball seat are an indication of looseness.

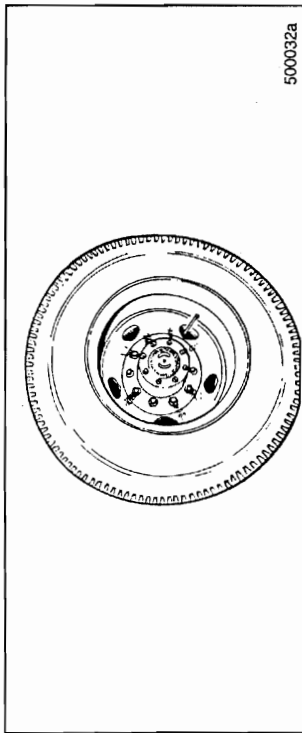

Look for cracks around the hand hole, stud hole and wheel. Look for broken studs, wheel damage or improperly seated lock rings.

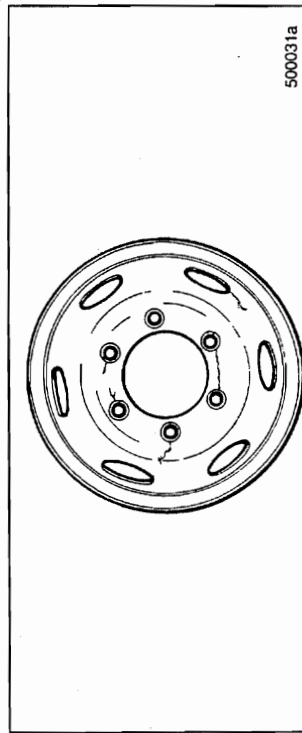

**MAINTENANCE AND LUBRICATION****Oil Contamination of Tires**

Lubricating oils, fuel oil, gasoline and other petroleum derivatives, if allowed to contact tires, will soften the rubber and destroy the tire. Preventive maintenance is necessary to ensure that oil leakage does not occur. The following areas should be inspected on a regular basis:

- Axle end seals
- Engine seals
- Transmission seals
- Drive axle seals
- Oil filters
- Oil and hydraulic lines (if equipped)

**MAINTENANCE AND LUBRICATION****CAUTION**

*Never bleed air from your tires in an attempt to gain traction for a vehicle stuck in snow, ice or mud. This practice provides no additional traction and typically results in underinflated tires. Never bleed air from a hot tire since that tire will then be underinflated.*

To adjust for pressure fluctuations induced by temperature changes associated with winter weather, it is recommended that tire inflation pressure be checked daily when the tires are cold (i.e., before the vehicle is driven). Always use an accurate tire pressure gauge.

**Inspection**

Inspect your tires daily. Look for bulges, cracks, cuts, penetrations and/or oil contamination. If any such damage is found, the tire must be thoroughly inspected by a qualified tire inspector and repaired or discarded immediately, at his discretion. Also, check for uneven wear. If found, a thorough inspection of front end parts and alignment should be made by a qualified mechanic.

**Tire Manufacturer's Data Book**

Specific and more detailed information can be obtained by referring to the technical data books provided by each tire manufacturer.

Subjects of interest are:

- High-speed or low-speed operation
- Repair, retreading and regrooving
- Use of tire chains
- Mixing radial and bias tires on the same vehicle
- Use of dynamometers
- Tire mounting/dismounting

**MAINTENANCE AND LUBRICATION****ELECTRICAL****Circuit Protection**

The circuit protection panel is located to the left of the passenger seat (on the engine tunnel). Remove the fasteners and the circuit board will be exposed.

Fuses are standard equipment for all circuits except the headlamps and windshield wipers. Circuit breakers are available as optional equipment.

**CAUTION**

*For proper installation of electrical accessories, all wiring should meet SAE requirements and be routed through the circuit protection panel with proper amperage fuses or Type II circuit breakers. (Headlights and wipers will be on Type I, cycling-type circuit breakers.)*

Some vehicles may be equipped with daytime running lights. For the daytime running lights to be operational, a DRL module must be installed in the relay socket marked either "DRL MOD" or "Running Lamps" on the electrical equipment panel. Do NOT install a standard relay into the daytime running light relay socket (marked either "DRL MOD" or "Running Lamps") or a short circuit in the headlight high beam circuit will result.

The headlight circuits are protected by SAE Type I (automatic reset-cycling) circuit breakers that automatically interrupt then restore the flow of current through the circuit in the event of an overload. This cycling will continue until the cause of the overload is repaired.

SAE Type II (automatic reset, non-cycling) circuit breakers (if equipped) provide a complete circuit disconnect until the overload is corrected. The power to the affected circuit breaker must be shut off before the circuit breaker will reset itself.

The circuit protection panel also provides access to battery, ignition and ground terminals for non-factory installed electronic equipment. (On V-MAC chassis, there are two serial link terminals for easy local connection of a trip recording device.)

**MAINTENANCE AND LUBRICATION****BATTERY****Jump-Starting Engine**

If you encounter a situation in which it is necessary to jump-start an engine, use the following procedures.

**WARNING**

Batteries which are to be linked together must be of the same voltage (12 to 12, 24 to 24). Batteries produce explosive gasses. Keep sparks, flames, cigarettes, etc., away from batteries at all times. Protect your eyes by wearing safety goggles. Be sure vehicles are NOT touching each other.

1. Connect positive (+) cable to positive (+) post of discharged battery.
2. Connect the other end of the same cable to the positive (+) post of the booster battery.
3. Connect the second cable, negative (-) side, to the other post of the booster battery.
4. Make the final connection on the engine block of the stalled vehicle AWAY FROM THE BATTERY, and stand back.
5. Start the vehicle with the booster batteries and then start the stalled vehicle. Shut down the vehicle with the booster batteries and remove the cables in the reverse order of connection.

**WARNING**

Do NOT connect the final negative (-) connection to the frame of the stalled vehicle. This would cause all current to flow through the master ground circuit breaker resulting in overload.

**REED**CONCRETE PLACING  
EQUIPMENT**MR SERIES MACK TRUCK****VENDR**FIGURE 01  
PAGE 57**MAINTENANCE AND LUBRICATION****Bulb Chart**

Light (Some lights may not be available on certain models)	Quantity (Varies with model)	CP/Watt	Trade No.
ABC Gauge Panel Cluster Lights	26	1.0CP	#161
Gauge Panel D	2	1.0CP	#161
Dome and Door Courtesy Light	2/3	12.0CP	#561
Map Light	1	3.0CP	#1816
Heater and Air Conditioner	1	1.0CP	#184
Clearance & Cab ID Marker (Standard)	5/7	3.0CP	#168
Clearance & Cab ID Marker (Premium)	5	4.0CP	#904
Side Turn Indicator	2	32.0CP	#570
Hook-Up Light	1	35W/600CP	#4406
Fog Light	2	55W	#H3
Headlight, Incandescent (Round)	2	60W/50W	#6015
Headlight, Halogen (Round)	2	65W/35W	#H6024
Headlight, Halogen (Rectangular)	2	65W/45W	#9004
Rear Tail Light Backup	2	32.0CP	#1156
Rear Stop, Tail and Turn Light	2	32.0/3.0CP	#1157
Front Turn Light	2	32.0/3.0CP	#3057

700106a

To prevent corrosion of the lamp socket terminals, particularly with the clearance and marker lamps, apply a coating of electrical sealing grease, such as Lubriplate DS-EX, to the socket and terminal assemblies.

**CAUTION**

Do not use electrical grease on any V-MAC connectors.

# **Bostrom**<sup>®</sup>

S E A T I N G

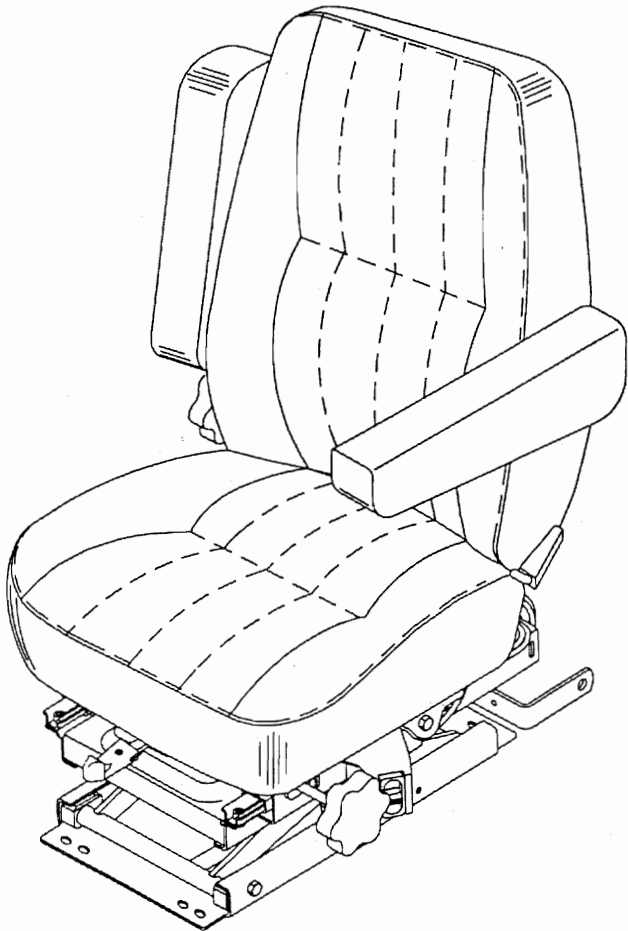

**TALLADEGA**<sup>TM</sup>  
SERIES  
905L/905/910  
AIR SUSPENSION SEATS

# REED

CONCRETE PLACING  
EQUIPMENT

## BOSTROM AIR SUSPENSION SEAT TALLADEGA SERIES

VENDR

FIGURE 02  
PAGE 02

### ILLUSTRATED PARTS BREAKDOWN

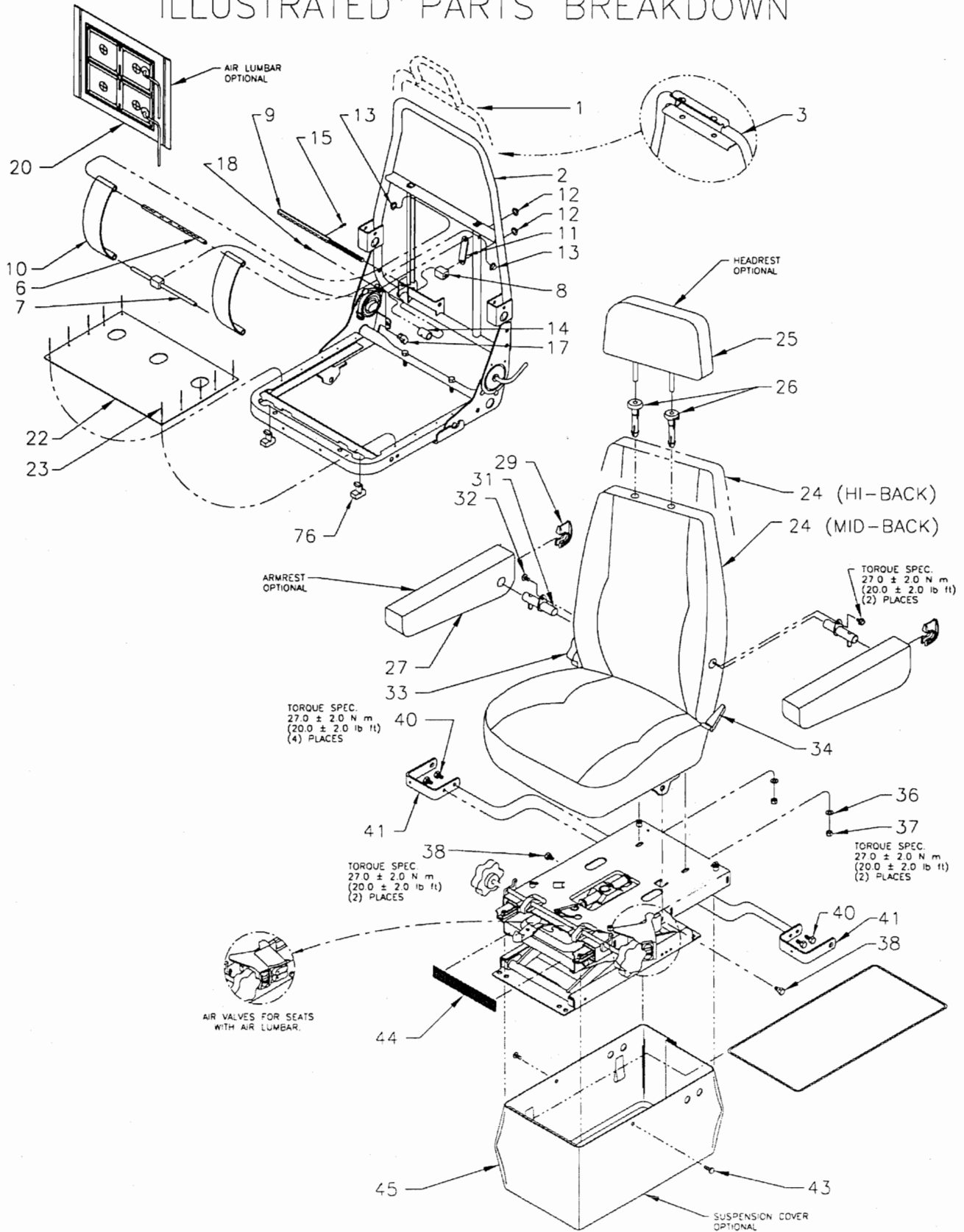

REVISION:



# BOSTROM AIR SUSPENSION SEAT TALLADEGA SERIES

VENDR

FIGURE 02  
PAGE 03

## PARTS REPLACEMENT LIST LOW PROFILE SUSPENSION SEAT

**ORDERING INSTRUCTIONS:** Order by Part Number, NOT Reference Number.

**HOW TO USE:** Find the corresponding part that you wish to replace on the exploded view illustration and note its reference number. Refer to list below and record part number, quantity required and description. Order cover pad kits or armrests by color and material.

**ORDER FROM:** Your truck dealer or Bostrom Authorized Distributor for your area.

REF NO	PART NO	DESCRIPTION	QTY	REF NO	PART NO	DESCRIPTION	QTY
1	6200906-001	Frame Assy. - High Back		35	6222007-001	Kit Fastener Mounting	
2	6200908-001	Frame Assy. - Mid Back		36	*	Washer Flat	2
3	6201118-001	Frame w/Headrest		37	*	Nut M8 x 1.25	2
4	6201316-001	Frame w/Air Lumbar		38	*	Shoulder Bolt M8	2
5	6222137-001	Lumbar Kit		39	6222005-001	ICP Bracket Kit	
6	*	Lumbar Support Shaft	1	40	*	Bolts	4
7	*	Lumbar Slide Shaft	1	41	*	ICP Bracket	2
8	*	Lumbar Adj. Block	1	42	**	Suspension Cover Kit	
9	*	Lumbar Adj. Shaft	1	43	*	Fastener	2
10	*	Lumbar Spring	2	44	*	Velcro	1
11	*	Lumbar Linkage	1	45	*	Suspension Cover	1
12	*	Push Nut 5/16"	2	46	6222155-001	Air Valve Kit	
13	*	Push Nut 3/8"	2	47	*	Valve Mounting Pod	1
14	*	Spacer	1	48	*	Air Valve	1
15	*	Roll Pin	1	49	*	Wire Tie 3"	3
16	6107030-001	Back Restriction Kit		50	*	Wire Tie 6"	1
17	*	Stop Block	1	51	*	Air Line	
18	*	Screw 10-32	1	52	6222133-001	Isolator Spring Kit	
19	6222141-001	Lumbar Kit (Air)		53	*	Rubber Bumper	2
20	*	Lumbar Bladder	1	54	*	Isolator Spring	2
21	6222157-001	Pan - Support Kit		55	*	Shoulder Bolt M10 x 1.50	1
22	*	Pan	1	56	*	Pivot Block Assy.	1
23	*	Rivets	10	57	*	Latch Spring	2
24	**	Upper or Cover Pad Kit		58	*	Split Poly Loom	2
25	**	Headrest		59	*	Spacer	1
26	6201133-001	Grommet	2	60	*	Latch Bar	1
27	**	Armrest Assy.		61	6222134-001	Control Handle Kit	
28	6222159-001	Kit Armrest Insert		62	*	Control Handle Assy.	1
29	*	Insert	1	63	*	Detent Pin Assy.	1
30	6222160-001	Kit Armrest Bracket		64	*	Spring Lockout	1
31	*	Screw 5/16 x 1/2 Hex Tap	1	65	*	Hex Head - Shoulder	1
32	*	Armrest Shaft	1	66	*	Washer	1
33	6200413-002	Lumbar Knob	1	67	*	Isolator Knob	1
34	6103653-003	Recliner Handle	1	68	*	Pop Rivet	1

REVISION:



## BOSTROM AIR SUSPENSION SEAT TALLADEGA SERIES

### ILLUSTRATED PARTS BREAKDOWN

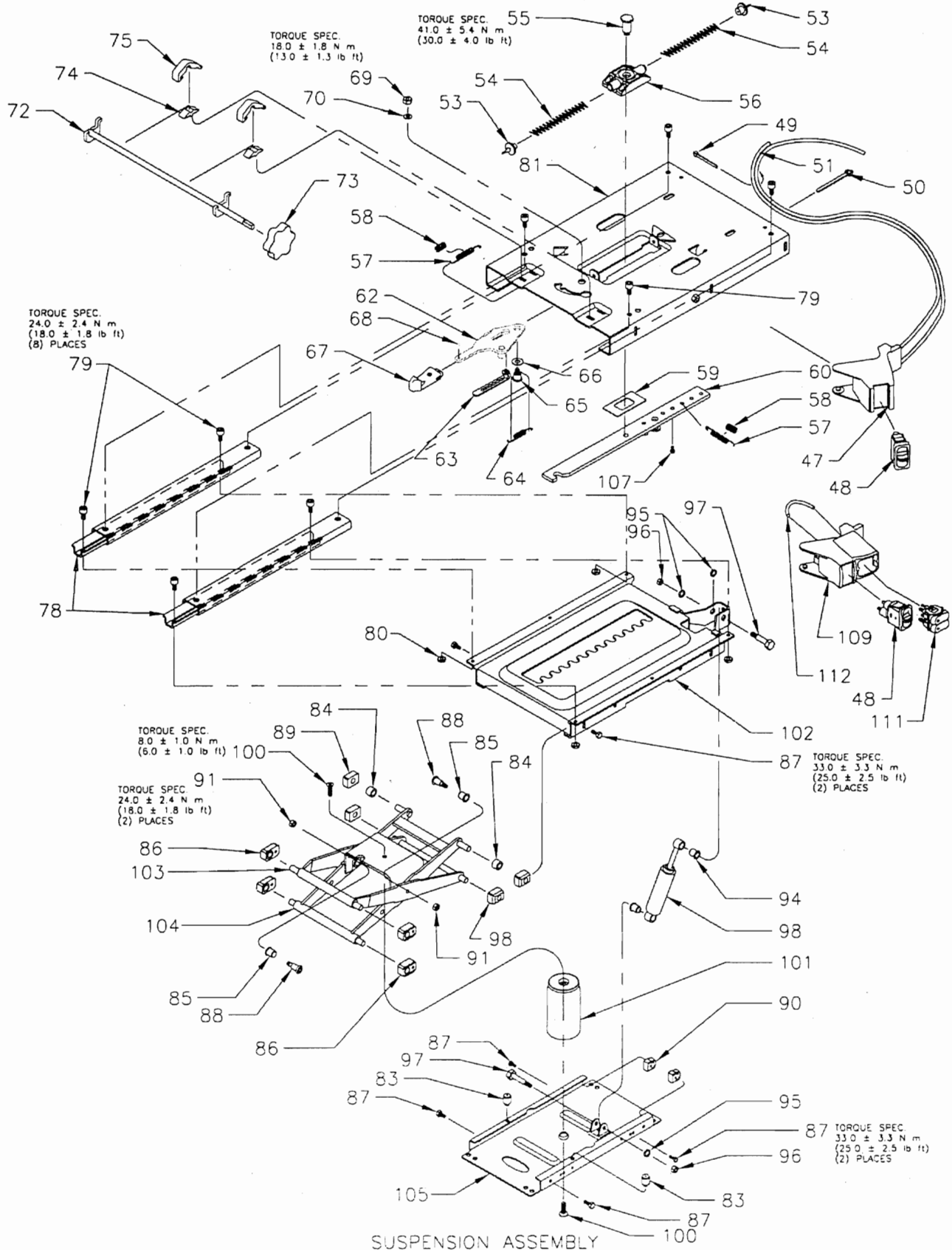

**BOSTROM AIR SUSPENSION SEAT  
TALLADEGA SERIES****PARTS REPLACEMENT LIST  
LOW PROFILE SUSPENSION SEAT  
CONTINUED**

REF NO	PART NO	DESCRIPTION	QTY	REF NO	PART NO	DESCRIPTION	QTY
69	*	Hex Nut M8 x 1.25 LK	1	92	6222078-001	Low Profile Damper Kit	
70	*	Washer	1	93	6222079-001	Heavy Duty Damper Kit	
71	6222135-001	Seat Tilt Replacement		94	*	Bearing Multilube	2
72	*	Tilt Rod Weldment	1	95	*	Washer Flat	2
73	*	Tilt Knob	1	96	*	Hex Nut	2
74	*	Bracket Tilt Rod	2	97	*	Bolt	2
75	*	Bracket Tilt Rod	2	98	*	Standard Damper	1
76	*	Slide Block Seat Tilt	2	99	6222084-001	Air Spring Kit	
77	6222165-001	Slide Rail Kit		100	*	Screw	2
78	*	Slide Rail	2	101	*	Air Spring Assy.	1
79	*	Screws	8	102	6201571-001	Upper Plate Weldment	1
80	*	Nuts	4	103	6065662-002	Outer Lever Assy.	1
81	6200641-004	Isolator Assy.		104	6106528-002	Inner Lever Assy.	1
82	6222076-001	Susp. Hardware Kit		105	6111111-001	Base Assy.	1
83	*	Rubber Bumper	2	106	6222138-001	Fore/Aft Restriction	
84	*	Spacer Roller	2	107	*	Restrictor Screw	1
85	*	Bearing Multilube	2	108	6222163-001	Air Valve Kit Assy.	
86	*	Bearing Block	4	109	*	Pod	1
87	*	Screw Cap M8 x 20mm	6	110	*	Air Lumbar Valve	1
88	*	Bolt Shoulder M8 x 1.25	2	111	*	Air Valve	1
89	*	Block Slide	4	112	*	Jumper Loop	1
90	*	Stop Block Assy.	2				
91	*	Nut Hex M8 x 1.25 LK	2				

\* EXCEPT AS NOTED, KITS CONTAIN ALL ITEMS DENOTED BY ASTERISK LISTED BELOW EACH KIT PART NUMBER.

\*\* SEE YOUR DEALER OR BOSTROM AUTHORIZED DISTRIBUTOR FOR UPPER, ARMREST, SUSPENSION COVER OR COVER PAD KIT PART NUMBERS APPROPRIATE FOR YOUR SEAT.

**COMFORT ADJUSTMENTS**

After installation the following comfort adjustments can be made to ensure the best performance.

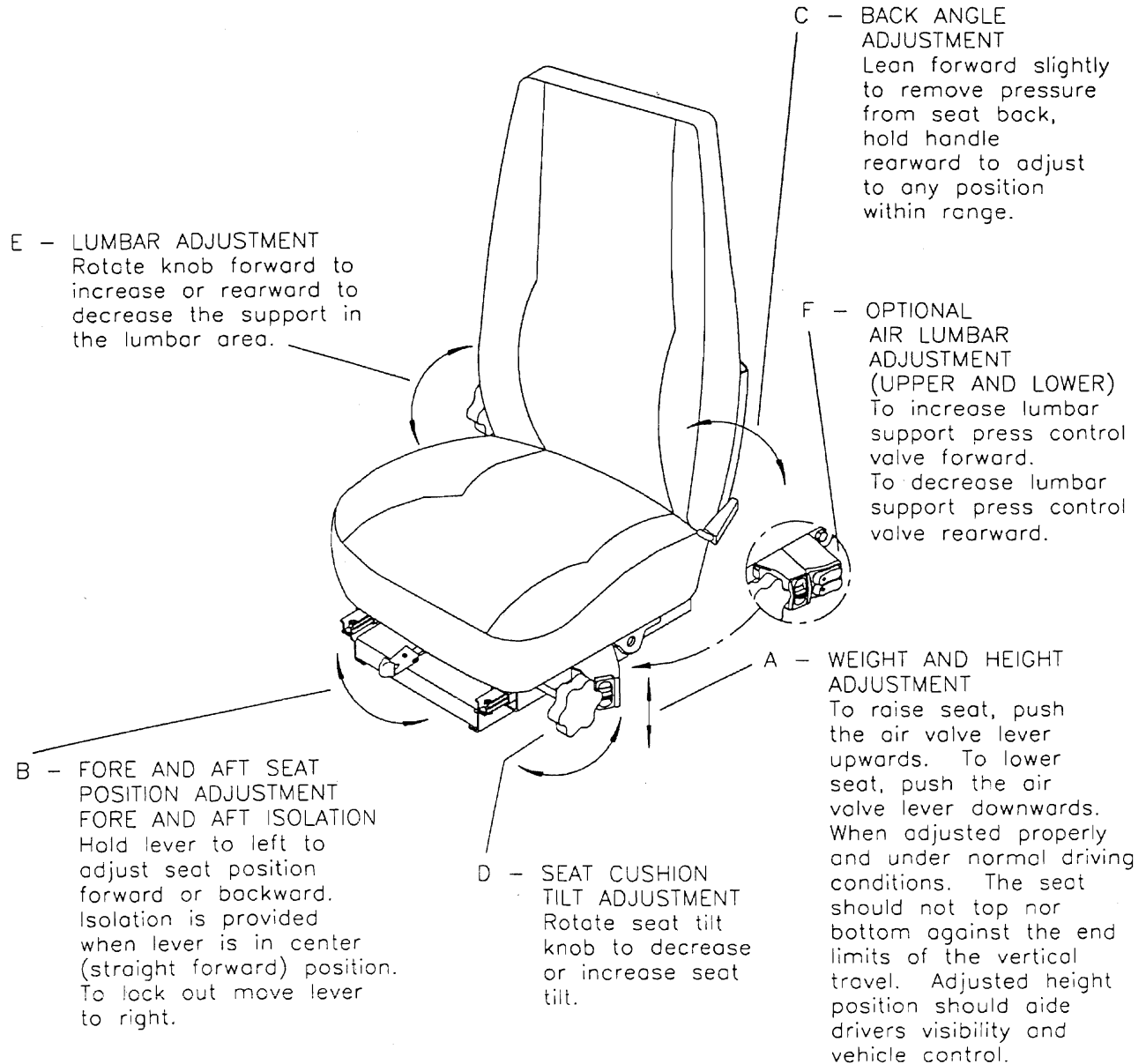
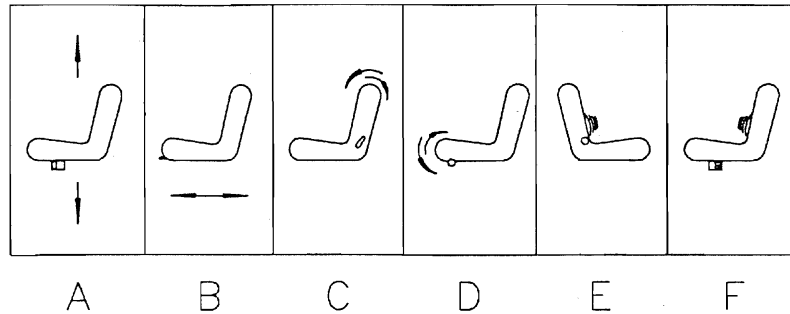

## REMOVAL / REASSEMBLY

### Air Spring Assembly (101) Removal/Reassembly

Remove complete seat assembly from vehicle.

1. Fill air spring assembly (101) so that seat is at maximum height (see comfort adjustments).
2. Block suspension up with a spacer placed between the base riser (105) and the upper frame (102).
3. Release air pressure from air spring so that seat is supported by spacer (see comfort adjustments).
4. Disconnect air line (51) from air spring assembly (101) by loosening air fitting and pulling air line out of fitting.
5. Remove top and bottom screw from air spring (101) and remove air spring assembly from suspension assembly.
6. Position air spring so that fitting at bottom of air spring (101) is toward the front of the seat. Install screw (100) into bottom of air spring (101).
7. Torque screw (100) at bottom of air spring assembly (101) to 10.0 +/- 1.0 ft.-lbs.
8. Install screw (100) at top of air spring assembly (101) and torque to 6.0 +/- 1.0 ft.-lbs.
9. Reconnect air line (51) to fitting in air spring assembly (101) by pushing air line into fitting and tightening fitting.
10. Fill air spring assembly (101) (see comfort adjustment) and remove spacer block.

### Damper Replacement (98)

Seat need not be removed from truck.

1. Be sure suspension is at maximum height. Add air if needed (see comfort adjustment).
2. Move channel assembly (81) to full frontward position to gain working room.
3. Remove shoulder bolts (97) and hex nuts (96).
4. Remove damper assembly.
5. Install new damper with flanges of bearings to the outside of the suspension. Add thrust washers (95) and install shoulder bolts (97) and hex nuts (96).

### Slide Rail (77) Replacement

1. Remove seat/back assembly (24). NOTE: See Seat/Back Assembly Removal/Reassembly procedure.
2. Once seat/back is removed, slide channel assembly (81) to the rear. Remove front screws (79) and nuts (80). Carefully, move channel assembly (81) to the front. Remove screws (79) and nuts (80).
3. Remove top screws (79).
4. Remove and install one slide rail (78) at a time.
5. Install new screws (79) and nuts (80).
6. Reassemble seat/back assembly (24).

**REMOVAL / REASSEMBLY****Suspension Rebuild Bearing/Slide Block Replacement**

1. Bleed all air from supply line. Disconnect air supply line to seat. Using air valve, exhaust all air from air spring. Remove complete seat assembly from vehicle.
2. Remove seat/back assembly (24) from suspension per procedures shown.
3. If seat assembly has a suspension cover (45), remove along with fasteners (43), after removing ICP bracket (41) and cap screws (40).
4. Block suspension up with a spacer placed between the base riser (105) and the upper frame (102).
5. Disconnect air line (51) from air spring assembly (101) by loosening air fitting and pulling air line (51) out of fitting.
6. Remove top and bottom screw from air spring (101) and remove air spring assembly from suspension assembly.
7. Remove damper assembly (98) by removing shoulder bolts (97) nuts (96) and washers (95) (see procedure for damper replacement).
8. Remove cap screws (87) from upper front bearing blocks (86) and lower rear stop block assemblies (90).
9. Remove upper plate weldment (102) by lifting and sliding it forward until bearing blocks (86) can be removed from cutouts in channels on upper frame (102). Then slide channel rearward until slide blocks (89) can be removed. Be careful not to pinch fingers in lever assembly.
10. Remove cap screws (87) from lower front bearing blocks (86) and slide lever assemblies (103 and 104) forward until bearing blocks (87) are removed from channel on base (105). Then slide lever assemblies rearward until slide blocks (89) are removed from channel. Be careful not to pinch fingers in lever assemblies.
11. Remove shoulder bolts (88) and nuts (91) from pivots of lever assemblies (103 and 104) and inspect. Replace if worn.
12. Replace bearings (85) at pivots on lever assembly (104) by pushing the old out and pressing in new. Flange of bearings (85) should be on outside of lever assembly (104).
13. Reassemble reverse order. Torque pivot shoulder bolts (88) to 20.0 +/- 2 ft.-lbs.
14. Put new bearing blocks (86) and slide blocks (89) on levers with beveled surfaces outward and slide levers with blocks into channel on base riser (105). Torque screws (87) to 30.0 +/- 3.0 ft.-lbs.
15. After putting bearing blocks (86), spacers (85) and slide blocks (89) on levers, slide upper frame assembly (102) over blocks. Line up screws (88) with bearing blocks (86) and torque screws (87) to 30.0 +/- 3.0 ft.-lbs.
16. Manually move suspension up and down to make sure there are no clearance problems. Be careful not to pinch fingers in linkage.
17. Block up suspension and reinstall air spring assembly (101). Torque upper screw (100) to 6.0 +/- 1.0 ft.-lbs. and lower screw (100) to 10.0 +/- 1.0 ft.-lbs. (see procedure shown for air spring reassembly).
18. Reinstall damper assembly (98) with washer (95) and nuts (96) (see procedure for damper replacement).
19. Reinstall suspension cover (45) and ICP brackets (41) if removed (see step #3).
20. Install assembly (24).

**Seat/Back Assembly (24)  
Removal/Reassembly**

1. Adjust the seat upper to most rearward position and remove two nuts (37) and flat washers (36) from underside of channel assembly (81).
2. Remove two shoulder bolts (38) from channel assembly (81).
3. Reverse procedure to reassemble.

**REED**CONCRETE PLACING  
EQUIPMENT**REXROTH A2F HYDRAULIC PUMP MOTOR**

VENDR

FIGURE 03  
PAGE 01**A2F**

Baureihe/Series 6.1

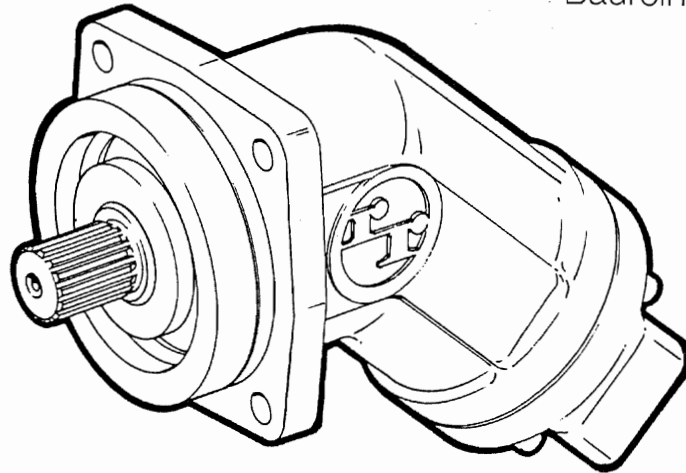
**NOTE**

Pretested and preassembled Original-Hydrumatik-subassemblies make quick and successful repairs possible. Should it be necessary to carry out repairs with individual components, our experience shows that only Original-Hydrumatik-seals, retaining rings, and bearings should be used. Basically, these should be changed when ever a unit is stripped down, as useful life still remaining cannot be visually determined. In addition, it would be dissapointing to spoil a well done repair by including marginally cheaper components. Giving us the unit type and fabrication number when ordering components will mean that you receive them quickly. Repairs are simple, but we recommend you take advantage of our training in order to acquire the necessary special knowledge. This applies also to specialists whom we ale always pleased to meed again to explain the repair of newly developed products.

**MANNESMANN  
REXROTH**

Hydrumatik GmbH

**R**

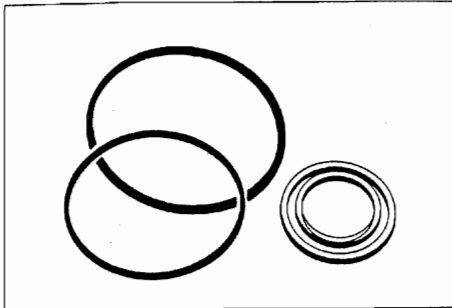

External seals

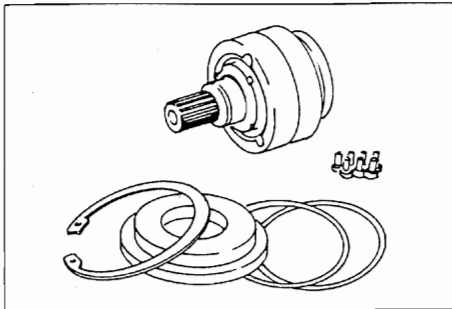
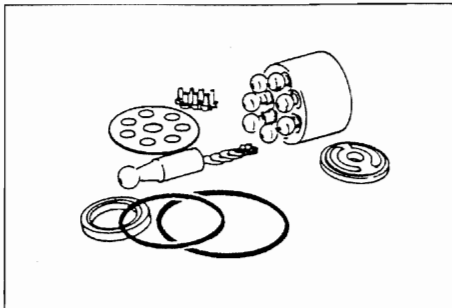
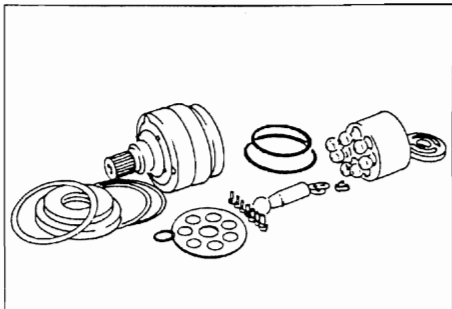
Rotary group, mechanical part; with sealkit,  
completely adjusted.Rotary group, hydraulic part; with sealkit,  
completely adjusted.Rotary group, complete; with sealkit, completely  
adjusted.

## C O N T E N T S

Seal sets/Sub-assemblies  
Notes/Section  
Drive Shaft/Seal  
Cover Plate/Seals  
Removal of rotary group  
Examination (notes)  
Installing rotary group  
Special equipment/Torques

## Shaft seals

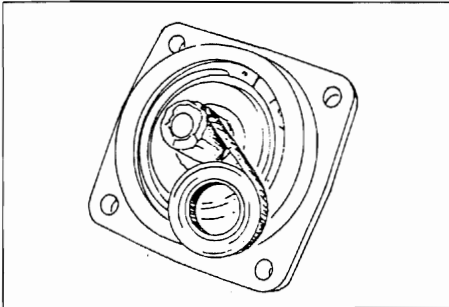

1

Remove protective cover. If keyed shaft, remove key.

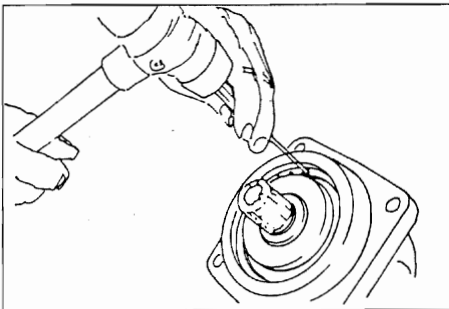

2

Free circlip and remove.

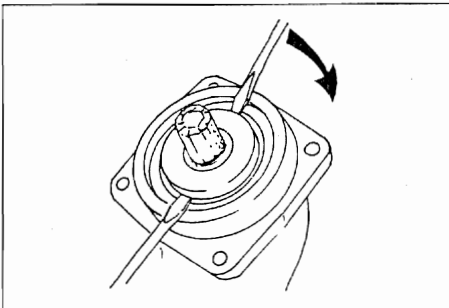

3

Prise off front cover.

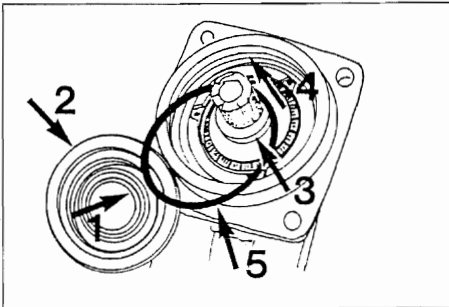

4

Visual check  
Shaft seal (1), Cover (2), drive shaft (3),  
housing (4), O-ring (5).

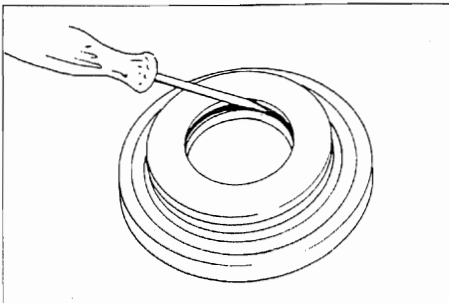

5

Remove old shaft seal.



Shaft seals

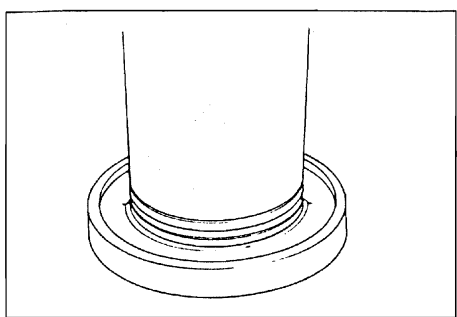

6

Press in the shaft seal ring to the correct position with a suitable sleeve.

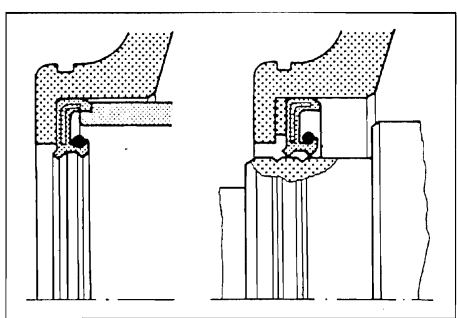

7

If the shaft is deeply grooved, insert shim behind seal.

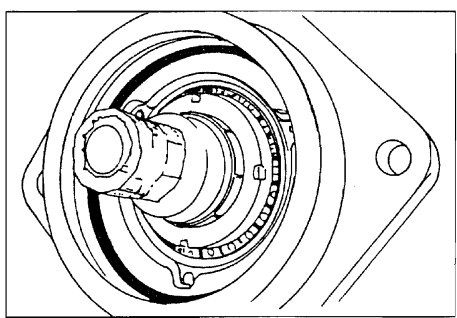

8

Fit new O-ring, ensure it is a snug fit. Grease O-ring and lips of shaft seal.

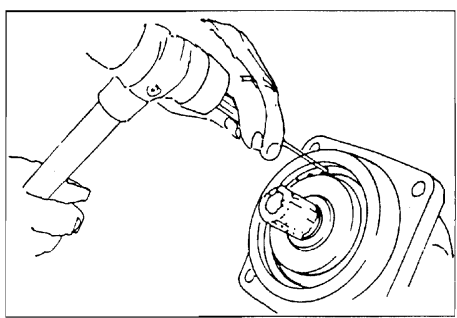

9

Fit circlip using a punch.

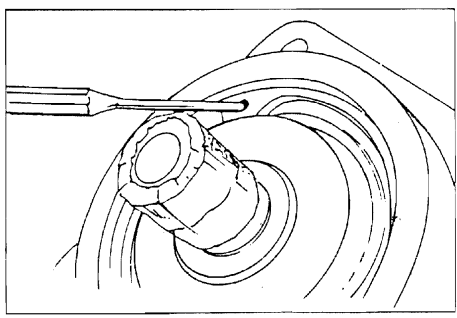

10

Check that circlip is well seated.

Cover plate/seals

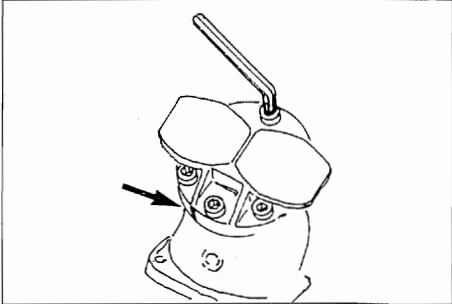

11

Mark position of cover plate (arrowed). Remove screws.

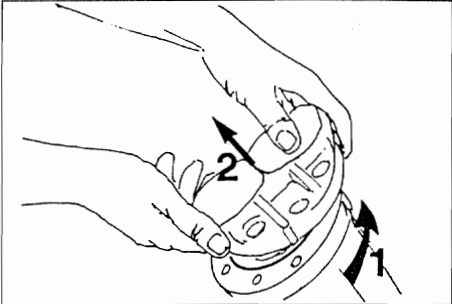

12

Swivel port plate on locating pin and lift off.

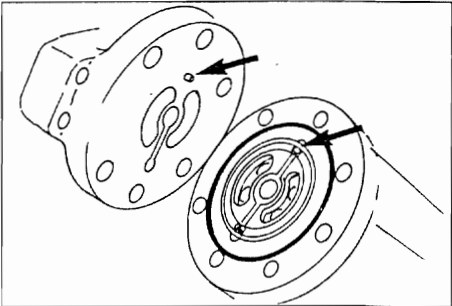

13

Note position of locating pin. (arrow).

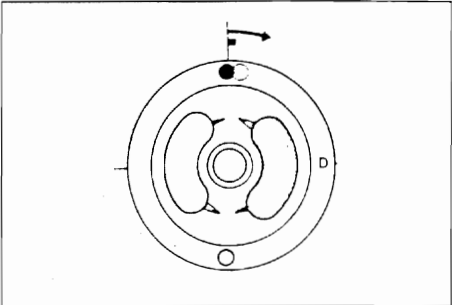

14

Pump, clockwise rotation. (Viewed on spherical surface.)

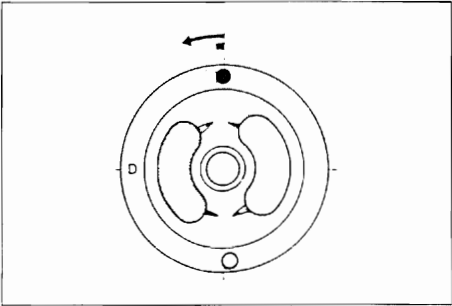

15

Pump, anti-clockwise rotation. (Viewed on spherical surface.)

## Cover plate/seals

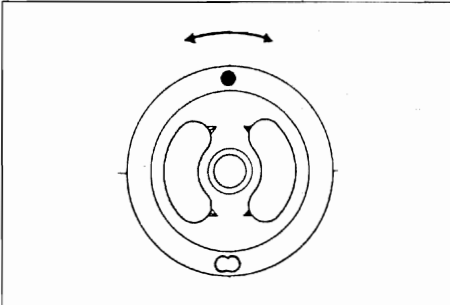

16

Motor, bi-directional. (Viewed on spherical surface.)

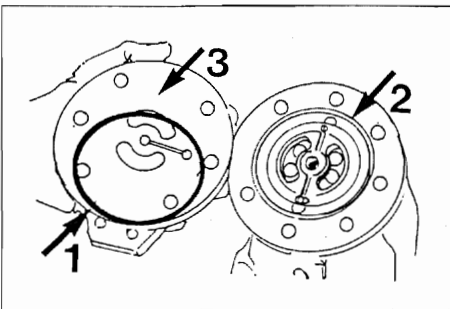

17

Visual check  
O-ring (1), Groove (2), Plate (3).

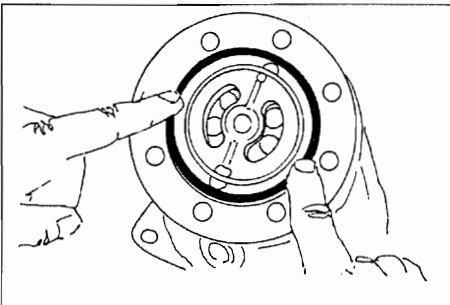

18

Lightly grease and fit O-ring.

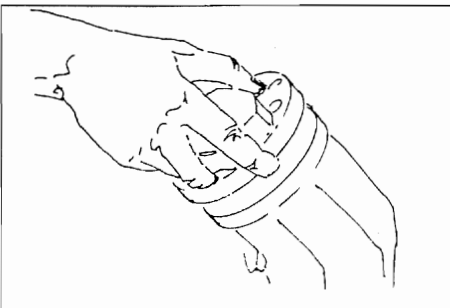

19

Assemble port plate to original mark (11), noting position of port plate (14-16). See notes fitting control plate.

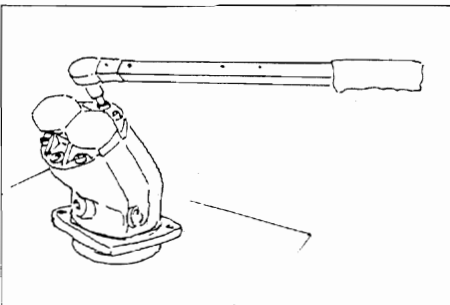

20

Tighten screws using torque wrench. See p. 14 for setting.

Removal of rotary group

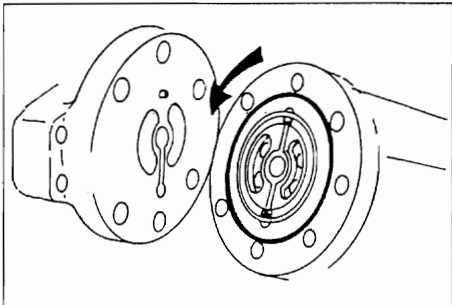

21

Remove cover plate (page 6). Rotate control plate to remove.

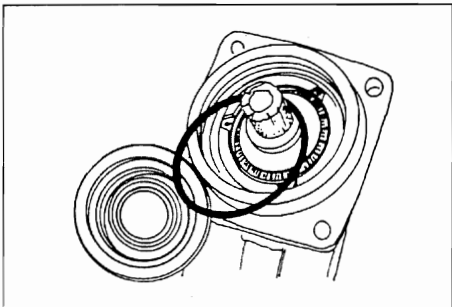

22

Remove front cover (page 4).

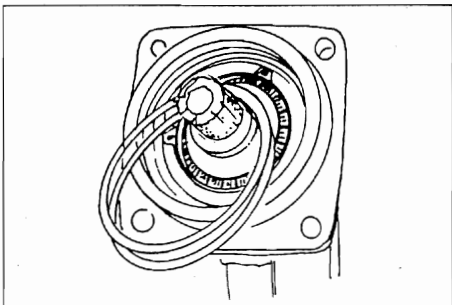

23

Remove shim(s).

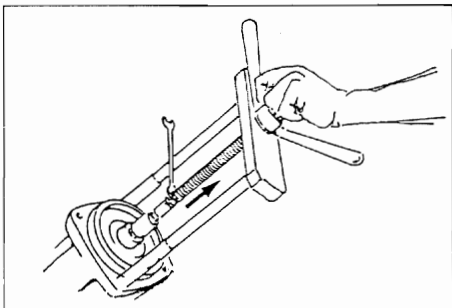

24

Remove rotary group with extractor. (See fig. 50).

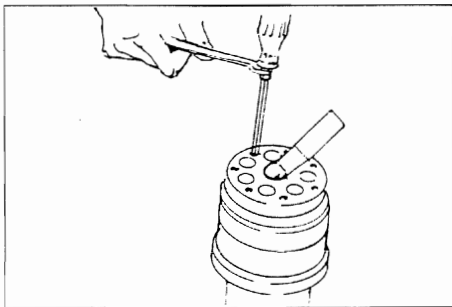

25

Remove retaining plate. The screws are held by loctite.

## Examination notes

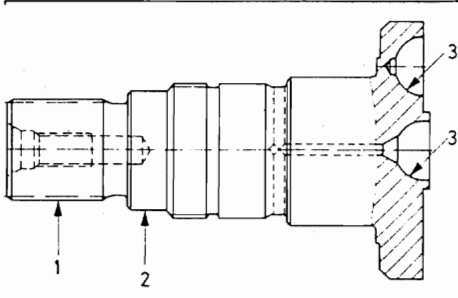

26

## Drive shaft

- 1.) Free of corrosion or erosion, no damage to splines or keyway.
- 2.) No trace of wear, free of scratches (p. 7).
- 3.) Cups free of scratches and no pitting.

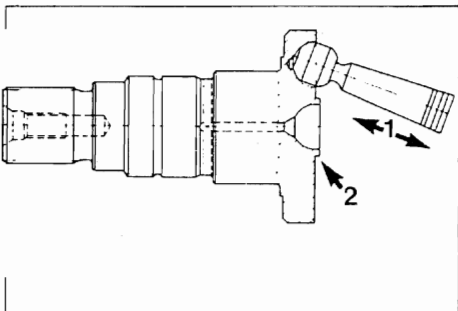

27

- 1.) Axial play of piston.
- 2.) Spigot.

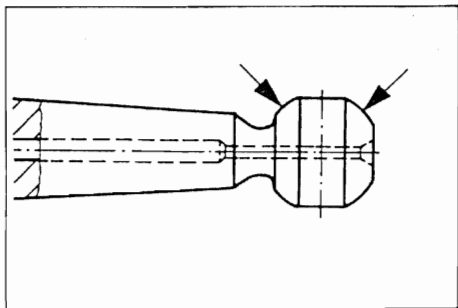

28

## Piston

- Free of scratches, no pitting (do not dismantle - tilt).

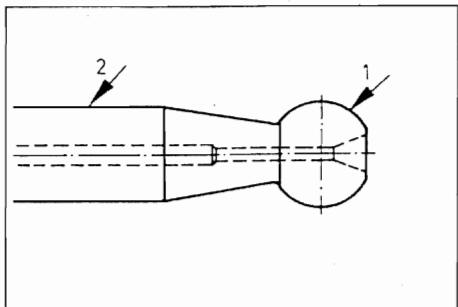

29

## Centre pin

- 1.) Free of scratches, no pitting (do not dismantle - tilt).
- 2.) Free of scratches.

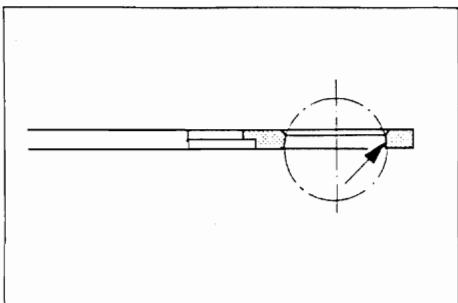

30

## Retaining plate

- Free of scratches, no wear.

## Examination notes

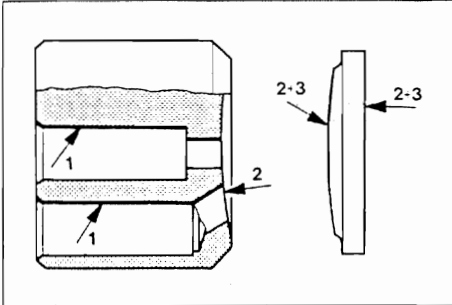

31

Cylinder block/Control plate

- 1.) Bores unscratched, and not worn.
- 2.) Faces, smooth and even, no cracks or scratches.
- 3.) Min. hardness 700 HV 10.

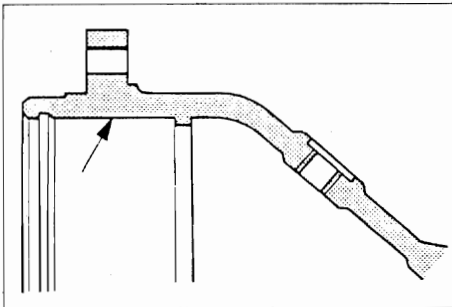

32

Housing

No damage or wear where bearings fit.

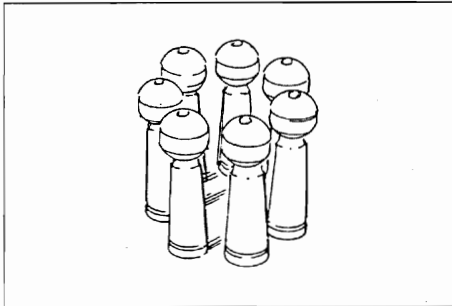

33

Only exchange piston as a complete set. When changing other components, re-calibration is required.

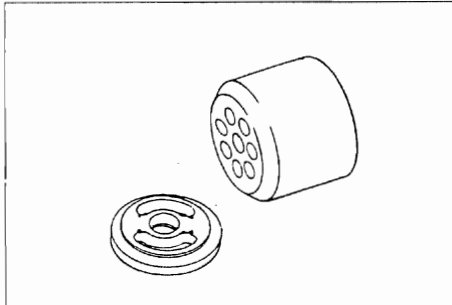

34

Exchange cylinder block and control plate as a pair.

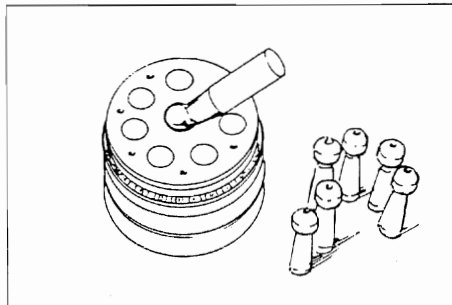

35

Insert centre pin with retaining ring.  
Correctly fit retaining plate.

### Installing rotary group

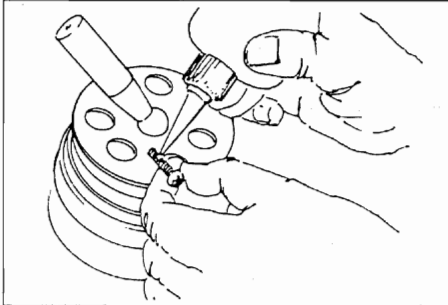

36

Apply loctite sparingly to screws only.

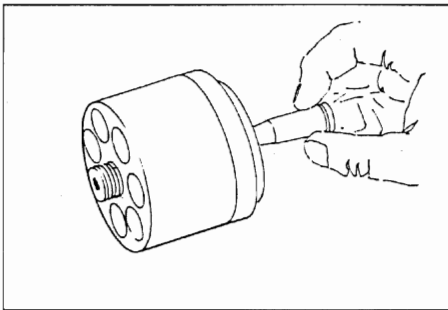

37

Heavily grease and fit spring pad and Belleville washers (using screwdriver).

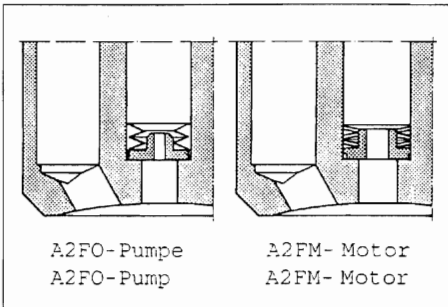

38

Make sure all parts are fitted in correctly!

Note:

A2FO - Pump- 4 Belleville washers/ Spring pad

A2FM - Motor- 6 Belleville washers/ Spring pad

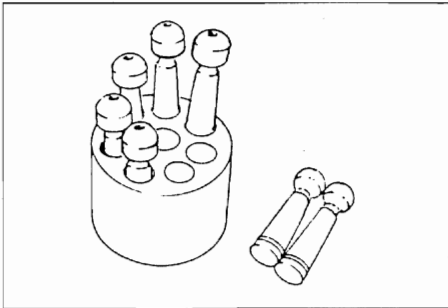

39

Fit pistons in bores.

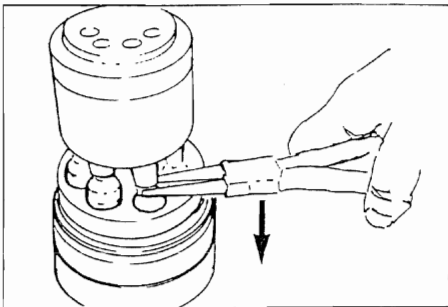

40

Press pistons firmly into cups with cylinder block held in central position.

Installing rotary group

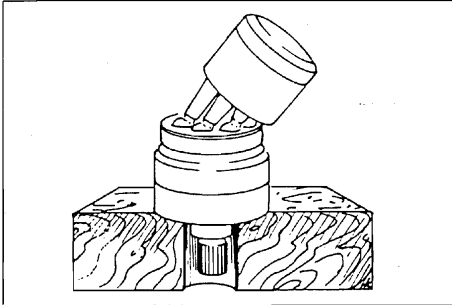

41

Swivel cylinder block to max. It fouling occurs fig. 40.

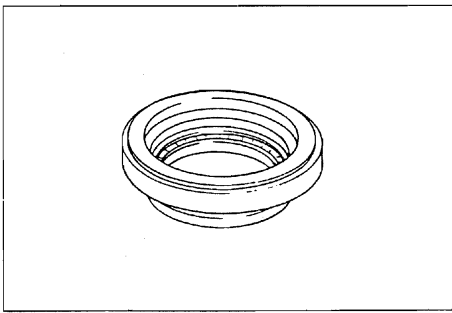

42

Is new shaft seal fitted? (comparisons fig 7).

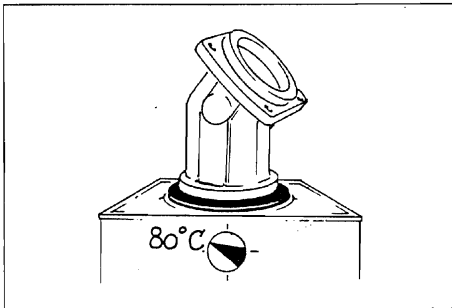

43

Heat the housing to 80°C.

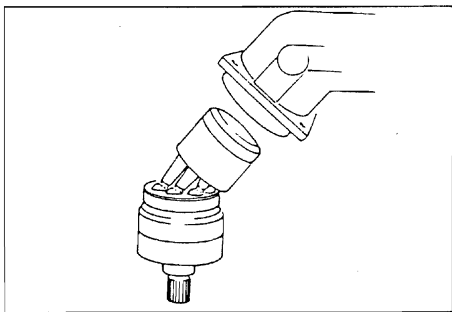

44

Fit pre-heated housing up to stop.

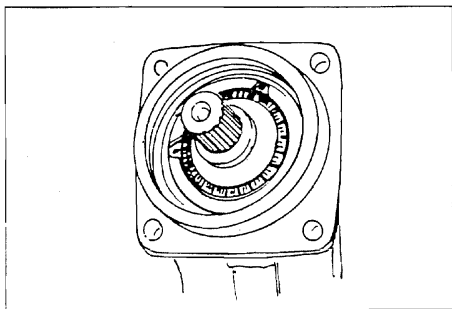

45

Re-position.



## Installing rotary group

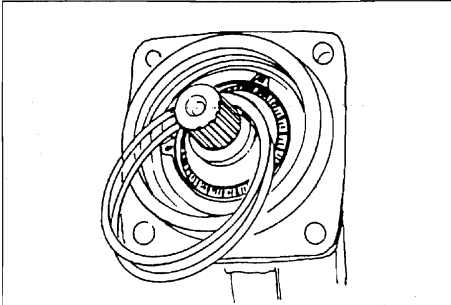

46

Insert shims and assemble to figs. 7 - 10.

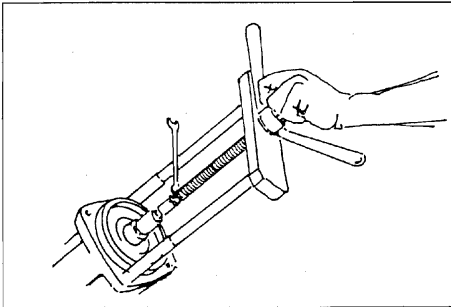

47

Pull the rotary group against the cover plate.  
Check that the cover plate cannot move!

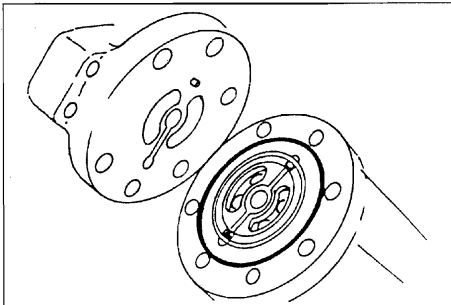

48

Completely assemble to figs. 18 - 20.

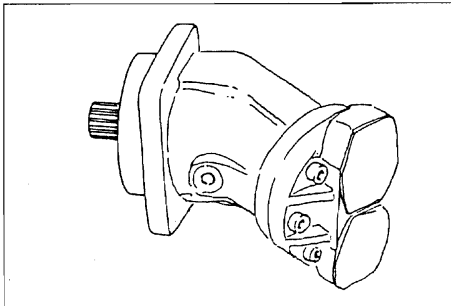

49

Seal connections to protect against dust.  
Corrosion protection (internal/external).  
Assembly complete.

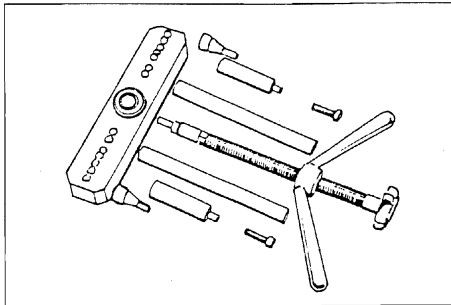

50

Extractor for rotary group (fig. 24).



# REXROTH A2F HYDRAULIC PUMP MOTOR

VENDR

FIGURE 03  
PAGE 13

## Tightening torques

### Anziehdrehmomente für Schafschrauben (Metrisches ISO-Regelgewinde)

Die nebenstehenden Werte für Anziehdrehmomente gelten nur für Schafschrauben mit metrischem ISO-Regelgewinde und Kopplauflagemäßen nach DIN 912, DIN 931 und DIN 933. Außerdem gelten diese Werte nur für leich- oder nicht geölte, unbehandelte Oberflächen, sowie nur bei Verwendung von Drehmoment- und Kräftebegrenzungsschlüsseln.	Gewindegröße	Festigkeitsklassen		
		8.8	10.9	12.9
		Anziehdrehmoment (Nm)		
	M 3	1.1	1.6	1.9
	M 4	2.9	4.1	4.9
	M 5	6	8.5	10
	M 6	10	14	17
	M 8	25	36	41
	M 10	49	69	83
	M 12	86	120	145
	M 14	135	190	230
	M 16	210	295	355
	M 18	290	405	485
	M 20	410	580	690
	M 22	550	780	930
	M 24	710	1000	1200
	M 27	1050	1500	1800
	M 30	1450	2000	2400

### Tightening torques for shaft bolts (Metric ISO Standard Thread)

The values for tightening torques shown in the table are valid only for shaft bolts with metric ISO-standard threads and head support surface dimensions in accordance with DIN 912, DIN 931 and DIN 933. These values are also valid only for light or unbleed, untreated surface as well as for use only with torque-indicating wrenches and force limiting tools.	Thread Size	Strength Classes		
		8.8	10.9	12.9
		Tightening Torque (lb.ft)		
	M 3	0.8	1.2	1.4
	M 4	2.1	3.0	3.6
	M 5	4.4	6.3	7.4
	M 6	7.4	10.3	12.5
	M 8	18.4	25.8	30.2
	M 10	36.1	50.9	61.2
	M 12	63.4	88.4	106.9
	M 14	99.5	140.0	169.5
	M 16	154.8	217.4	261.6
	M 18	213.7	298.5	357.4
	M 20	302.2	427.5	508.5
	M 22	405.4	574.9	685.4
	M 24	523.5	737.0	884.4
	M 27	773.9	1105.5	1326.6
	M 30	1068.7	1474.0	1768.8

### Anziehdrehmomente für Verschlusschrauben VSTI (Metrisches Feingewinde)

Gewindegröße	Bezeichnung	Anziehdrehmoment (Nm)
M 8 x 1	VSTI 8 x 1 -ED/SA	= 5
M 10 x 1	VSTI 10 x 1 -ED	= 10
M 12 x 1.5	VSTI 12 x 1.5 -ED	= 20
M 14 x 1.5	VSTI 14 x 1.5 -ED	= 30
M 16 x 1.5	VSTI 16 x 1.5 -ED/SA	= 30
M 18 x 1.5	VSTI 18 x 1.5 -ED/SA	= 40
M 20 x 1.5	VSTI 20 x 1.5 -ED/SA	= 50
M 22 x 1.5	VSTI 22 x 1.5 -ED	= 60
M 26 x 1.5	VSTI 16 x 1.5 -ED/SA	= 70
M 27 x 2	VSTI 27 x 2 -ED	= 90
M 30 x 1.5	VSTI 30 x 1.5 -ED/SA	= 100
M 33 x 2	VSTI 33 x 2 -ED/SA	= 120
M 42 x 2	VSTI 42 x 2 -ED/SA	= 200
M 48 x 2	VSTI 48 x 2 -ED	= 300

### Tightening torques for locking screws VSTI (Metric ISO fine thread)

Thread Size	Designation	Tightening Torque (lb.ft)
M 8 x 1	VSTI 8 x 1 -ED/SA	= 4
M 10 x 1	VSTI 10 x 1 -ED	= 7
M 12 x 1.5	VSTI 12 x 1.5 -ED	= 15
M 14 x 1.5	VSTI 14 x 1.5 -ED	= 22
M 16 x 1.5	VSTI 16 x 1.5 -ED/SA	= 22
M 18 x 1.5	VSTI 18 x 1.5 -ED/SA	= 29
M 20 x 1.5	VSTI 20 x 1.5 -ED/SA	= 37
M 22 x 1.5	VSTI 22 x 1.5 -ED	= 44
M 26 x 1.5	VSTI 16 x 1.5 -ED/SA	= 51
M 27 x 2	VSTI 27 x 2 -ED	= 66
M 30 x 1.5	VSTI 30 x 1.5 -ED/SA	= 74
M 33 x 2	VSTI 33 x 2 -ED/SA	= 88
M 42 x 2	VSTI 42 x 2 -ED/SA	= 147
M 48 x 2	VSTI 48 x 2 -ED	= 220

### Anziehdrehmomente für Seal-Lock Bundmuttern (Metrisches ISO-Regelgewinde)

Die nebenstehenden Werte für Anziehdrehmomente gelten nur für Seal-Lock Bundmuttern der Festigkeitsklasse 8.8 mit metrischem ISO-Regelgewinde.	Gewindegröße	Festigkeitsklassen		
		8.8	10.9	12.9
		Anziehdrehmoment (Nm)		
	M 6	10	/	/
	M 8	22	/	/
	M 10	40	/	/
	M 12	69	/	/
	M 14	110	/	/
	M 16	170	/	/

### Tightening torques for seal-lock nuts (Metric ISO-Standard Thread)

The values for tightening torques shown in the table are valid only for seal-lock-nuts of the strength class 8.8 and with metric ISO-standard thread.	Thread size	Strength Classes		
		8.8	10.9	12.9
		Tightening Torque (lb.ft)		
	M 6	7.4	/	/
	M 8	16.2	/	/
	M 10	29.5	/	/
	M 12	50.9	/	/
	M 14	81.1	/	/
	M 16	125.3	/	/

### Anziehdrehmomente für Linsenschrauben mit Kreuzschlitz DIN 7985 (Metrisches ISO-Regelgewinde)

Die nebenstehenden Werte für Anziehdrehmomente gelten nur für Linsenschrauben mit Kreuzschlitz DIN 7985 der Festigkeitsklasse 8.8 mit metrischem ISO-Regelgewinde.	Gewindegröße	Festigkeitsklassen		
		8.8	10.9	12.9
		Anziehdrehmoment (Nm)		
	M 3	1.1	/	/
	M 4	2.9	/	/
	M 5	6	/	/
	M 6	10	/	/
	M 8	25	/	/
	M 10	49	/	/

### Tightening torques for cross-slotted lens head screws DIN 7985 (Metric ISO-Standard Thread)

The values for tightening torques shown in the table are valid only for cross-slotted lens head screws DIN 7985 of the strength class 8.8 and with metric ISO-standard thread.	Thread size	Strength Classes		
		8.8	10.9	12.9
		Tightening Torque (lb.ft)		
	M 3	0.8	/	/
	M 4	2.1	/	/
	M 5	4.4	/	/
	M 6	7.4	/	/
	M 8	18.4	/	/
	M 10	36.1	/	/

**General advice**

- Make yourself familiar with the equipment of the machine.
- Only operate the machine if you are completely familiar with the operating and control elements as well as the functioning of the machine.
- Use your safety equipment like helmet, safety shoes and hearing protection.
- Make yourself familiar with your working field.
- Only operate the machine for its intended purpose.

Please observe the guidelines of the Professional Association and the machine manufacturer.

**Before starting**

- Observe the operating instructions before starting.
- Check the machine for remarkable faults.
- Do not operate the machine with defective instruments, warning lights or control elements.
- All safety devices must be in a secure position.
- Do not carry with you movable objects or secure them to the machine.
- Keep oily and inflammable material away from the machine.
- Before entering the driver's cabin, check if persons or obstacles are beside or beneath the machine.
- Be careful when entering the driver's cabin, use stairs and handles.
- Adjust your seat before starting.

**Start**

- When starting all operating levers must be in "neutral position".
- Only start the machine from the driver's seat.
- Check the indicating instruments after start to assure that all functions are in order.
- Do not leave the machine unobserved when the motor is running.
- When starting with battery connection cables connect plus with plus and minus with minus. Always connect mass cable (minus) at last and cut off at first.

**Attention**

- Exhaust gas is dangerous. Assure sufficient fresh air when starting in closed rooms!

**Hydraulic equipment**

1. Hydraulic equipment is standing under high pressure.  
 High pressure fluids (fuel, hydraulic oil) which escape under high pressure can penetrate the skin and cause heavy injuries.  
Therefore immediately consult a doctor as otherwise heavy infections can be caused.
2. When searching leakages use appropriate auxiliary devices because of the danger of accidents.
3. Before working at the hydraulic equipment, lower pressure to zero and lower working arms of the machine.
4. When working at the hydraulic equipment, absolutely stop motor and secure tractor against rolling away (parking brake, shim)!
5. When connecting hydraulic cylinders and motor pay attention to correct connection of hydraulic flexible hoses.
6. In case of exchanging the ports, the functions are vice versa (f. ex. lift-up/lower) - danger of accidents!
7. Check hydraulic flexible hoses regularly and replace them in case of damage or wear! The new hose pipes must comply with the technical requirements of the machine manufacturer!

-  Orderly disposal or recycling of oil, fuel and filters!

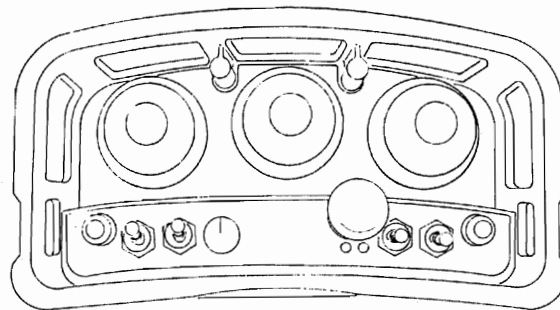
NBB  
NACHRICHTEN  
TECHNIK

S/N :

## 1. STANDARD SPECIFICATION

- Portable transmitter with two replaceable 7,2 volt NiCd batteries, halter and waist straps
- Receiver with NBB adapter plate for fastening purposes (Only PNN-BUS-3)
- Receiver with 4 fastening angles (PNN-BUS-5)
- Multi-pole connecting cable for the receiver, to your specifications
- Automatic battery charger with charging adapter (rapid charging in three hours)

The actual delivery specification is as detailed on the confirmation of order or the delivery note accompanying the goods!

## 2. SAFETY PRECAUTIONS

Even if you are accustomed to working with radio control systems, read these operating instructions without fail before using this equipment. Only this document contains the latest information relating to your NBB radio control system.

Please refer to the accompanying registration documents for the explanatory notes on obtained an operating permit. Observe all applicable work-safety and accident prevention regulations without fail. Only fully trained, authorized personnel may use the NBB radio control equipment. Components, etc. built into the NBB equipment for safety purposes must be regularly inspected. (See point 6 of this instruction)

If the NBB radio control unit develops a fault, it must be shut down immediately. The transmitter should be switched off with the EMERGENCY-OFF switch. The connecting cable must be disconnected from the crane connecting socket (terminal) on the receiver. The repair of the equipment must not be carried out other than by NBB or an NBB authorized technician.

Failure to observe these recommendations will put both you yourself and others at risk. Under these circumstances, NBB rescinds the guarantee and any other form of liability. This radio control unit is designed exclusively for the control of construction machines and industrial plants. Only under these conditions are the safety systems (EMERGENCY-OFF, zero setting) fully effective. No other form of use is permitted. Any non-observance of this condition will relieve NBB of all liability.

Nano, Nano-S-A2-HC



Nano-Vario

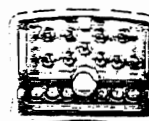

Nano, Nano-S-A2-HC



Nano-Vario

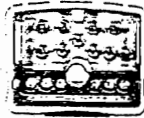

**3. TRANSMITTER**

To make the unit ready for use, insert the battery into the battery compartment. To remove the battery, depress the pin and push out the battery. The power supply to the transmitter is activated with the EMERGENCY-OFF switch (when depressed, the EMERGENCY-OFF switch can also be secured by removing the key cap). The green LED on the transmitter control panel must flash regularly. Commands can now be input by means of the controls. The operating period with a charged battery is approximately 8 hours with the transmitter in continuous use. When the red 'Battery' indicator lamp lights up, the battery is nearing exhaustion. The transmitter can be operated for approximately 15 minutes more in this condition. During this time, bring the crane to a safe position and install a new battery. Removal of the battery interrupts the radio link. As a result, the master switch for the crane must be switched on again. Charge the discharged battery with the charger supplied.

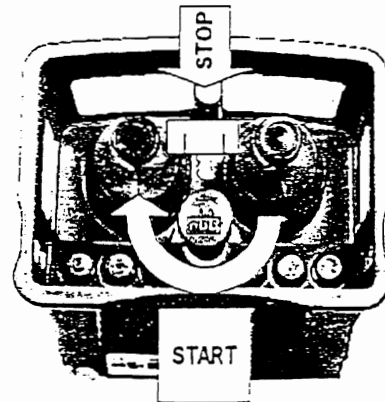
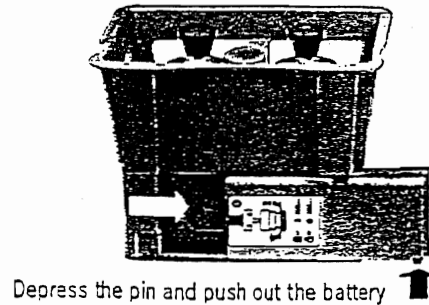

**4. BATTERY CHARGER**

The red indicator lamp indicates that the battery charger is ready for use. Place the battery in the charging well; it will now be charged. When the red LED goes out, the charging process is concluded. No harm will come to the battery if it is left in the charger beyond the required charging time. Do not use the charger other than in dry rooms having a min-max temperature range of 0-40°C. A charged battery is a concentrated energy source. Never store a charged battery in a toolbox or similar where it could be short-circuited by metal components (even a key in your trouser pocket can cause a short circuit).

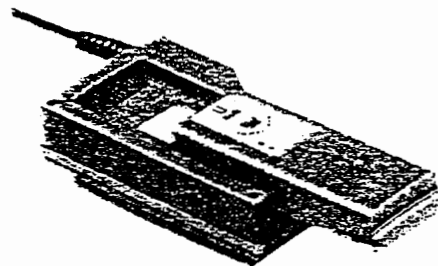

**5. RECEIVER (PNN-BUS-3 and PNN-BUS-5)**

The receiver is connected to the crane with the multi-pole connecting cable supplied. Please observe the instructions issued by the crane manufacturer. The power supply to the receiver is generally effected by way of the connecting cable.

- In general, an earth lead is required in the case of cranes which have not previously been operated under radio control. Failing this, the receiver electronic circuit will not receive any power supply. Take care to ensure that the operating voltage of the receiver complies with the electrical specifications of the crane. The applicable operating voltage is specified in the supplement.

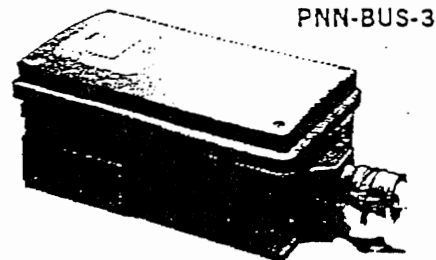

- Never expose the receiver to a high pressure cleaning jet. This also applies to the transmitter.
- The receiver should always be fixed vertical at the outside panel of the switching cabinet. The antenna should reach over the top of the panel.

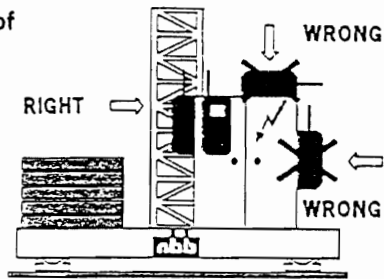

**6. OPERATING THE SYSTEM**

Safety equipment in the NBB radio control system:

- In the transmitter:**
  - EMERGENCY-OFF switch with automatic disconnection from the power supply
  - Automatic zeroing
- In the receiver:**
  - Duplicated 2-channel evaluation of the EMERGENCY-OFF signal
  - Automatic zeroing when switched on again after radio signal interruption
  - Inhibition of radio control commands at the relay level if EMERGENCY-OFF circuit defective.

To ensure troublefree operation, observe the following operating instructions precisely. Subject to the transmitter being in operating condition, the crane's master switch can only be switched on provided no command transmitter is actuated. The necessary command for this purpose is initiated by the 'ON/HOOTER' button. This activates a warning signal on the crane. After the crane has been switched on, this button serves for the subsequent activation of the hooter as required by safety at work regulations.

If the NBB radio control unit remains unused for a prolonged period, we strongly recommend that the battery be charged from time to time (approximately every four weeks). This will prevent it from becoming discharged and will prolong its working life. If an extended period of disuse is intended, we recommend that the battery be removed from the transmitter.

**Changing the frequency:**

To change the frequency, hold down the 'ON/HOOTER' button while simultaneously operating the 'FREQUENCY CHANGE' button until the hooter sounds. (Please observe the accompanying registration conditions, see page 5, point 9).

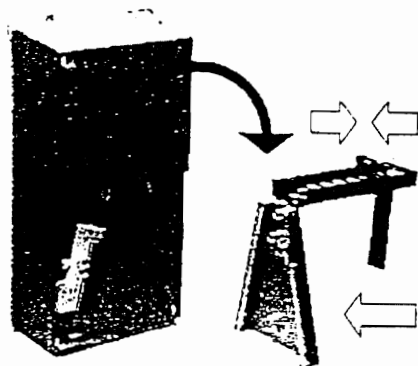

Mounting-possibilities of the PNN-BUS-3 or of the PNN-BUS-5.

PNN-BUS-5

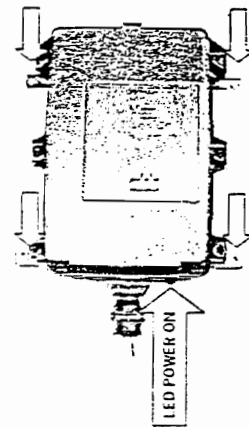

Nano-Vario

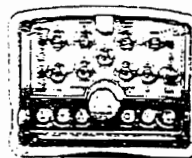

Nano / Nano-S-A2-HC

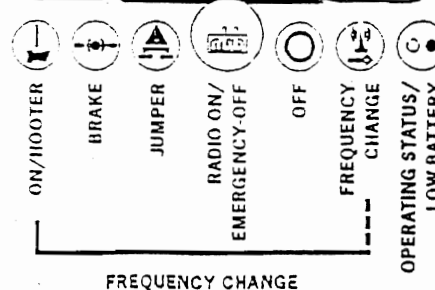
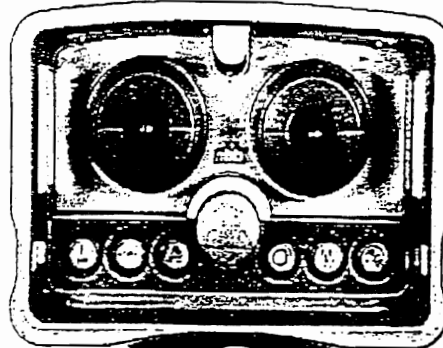

**NBB NANO-S-A2-HC  
RADIO REMOTE CONTROL**

**TEACH-IN: Individual Setting of Analog Channels (Basic Setting) at Nano Transmitter\*.**  
The output signals of the analog channels can be individually programmed from the transmitter.

**Activate programming mode**



**Select analog function**



**Save "contact point"**



**Save maximum speed**



**Program opposite direction?**



Yes →

**End programming mode**



**Programming of next function?**



Yes →

Mounting the key cap on the rotary switch opposite the battery compartment and then turning this switch activates the programming mode.

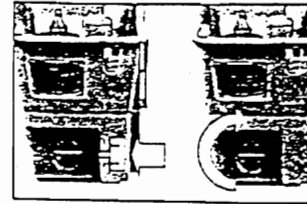

To determine which analog function is to be programmed, it is sufficient to briefly turn the appropriate master switch fully in the direction of this function.

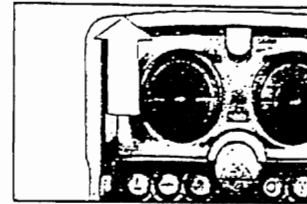

The master switch is now turned until the required "contact point" (less than 50% of the master switch turning range) is reached. To save this value, the "SAVE" ("ON/HORN") key must be pressed at this position.

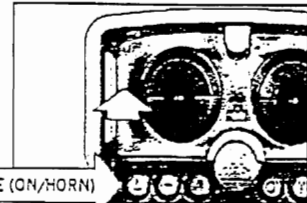

The upper initial value is saved by turning the master switch (further than 50% of the master switch turning range) until the maximum speed of the function is reached, and then pressing again the "SAVE" ("ON/HORN") key.

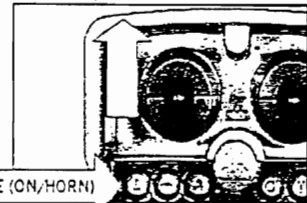

The opposite direction of this function can then be programmed the same way immediately afterwards.

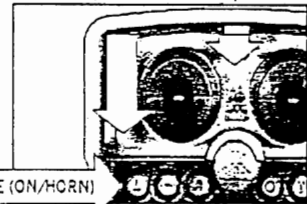

If the rotary switch is reset, the programming mode is left and working with this function can commence. Removing the key cap secures the transmitter against inadvertent teaching.

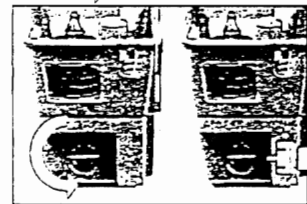

When programming several analog channels consecutively, the programming function must be left after saving a function, in order to release the next channel for programming, after turning the programming switch back on by briefly turning the master switch to the full.

**Please note:**

**No frequency change is possible in the programming mode!**

The control is ready to operate.

\*Please refer to the scope of supply of your facility.

**TEACH-IN: Individual Setting of Analog Channels (Basic Setting) at Nano Transmitter with Potentiometer Control\***

The output signals of the analog channels can be individually programmed from the transmitter.

**Activate programming mode**



**Select analog function**



**Save "contact point"**



**Save maximum speed**



**End programming mode**



**Programming next function?**



The control is ready to operate.

Mounting the key cap on the rotary switch opposite the battery compartment and then turning this switch activates the programming mode.

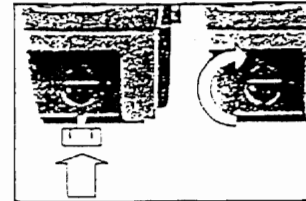

To determine which analog function is to be programmed, it is sufficient to briefly turn the appropriate potentiometer fully in the direction of this function and then back again.

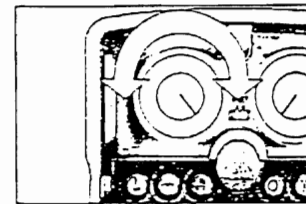

The potentiometer is now turned until the required "contact point" (less than 50% of the potentiometer turning range) is reached. To save this value, the "SAVE" ("ON/HORN") key must be pressed at this position.

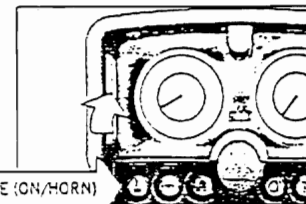

The upper initial value is saved by turning the potentiometer (more than 50% of the potentiometer turning range) until the maximum speed of the function is reached, and then pressing again the "SAVE" ("ON/HORN") key.

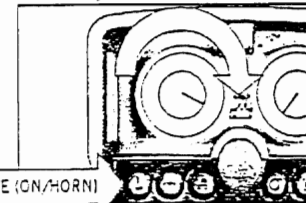

If the rotary switch is reset, the programming mode is left and working with this function can commence. Removing the key cap secures the transmitter against inadvertent teaching.

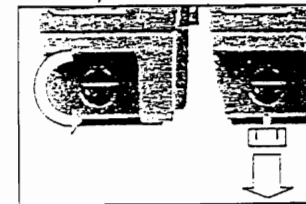

When programming several analog channels consecutively, the programming function must be left after saving a function, in order to release the next channel for programming, after turning the programming switch back on by briefly turning the master switch to the full.

**Please note:**  
No frequency change is possible in the programming mode!

**Saving two different basis settings (optional)\***

If required, the unit can be supplied with two saving options for the basic setting. These can be selected using an additional key switch or rotary switch once saved. For both settings, the individual analog functions must be programmed separately.

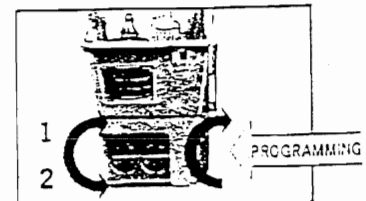

\*Please refer to the scope of supply of your facility.



## 7. FUNCTION CHECKS

Regular function checks of the NBB radio control unit are essential to ensure that operating safety is maintained. In the case of a single-shift daily operation, we recommend that the checks be carried out once a week. They can be performed with the aid of the indicator lamps on the receiver. For this purpose, the transmitter must be in operating condition.

- First, connect only the receiver - the transmitter remains switched off.
- Switch on the transmitter by releasing the EMERGENCY-OFF button.
- Now test the command functions (always starting at the lowest stage) and check that the crane responds correctly. In particular, make sure that the danger area is clear of all personnel. **Failure to do so may result in an ACCIDENT.**
- **EMERGENCY-OFF check.** Press the EMERGENCY-OFF button on the transmitter until it locks. The crane's master contactor must drop out after a maximum of 1/2 second.

### Checking the LEDs of the receiver

- **LED1: POWER ON.** If the LED does not light up, check the power supply. If the power supply lead is in satisfactory condition, notify your service centre.
- **LED2: HF AVAILABLE.** Remains lit continuously when the transmitter is switched on.  
(not significant in the case of scanner operation).
- **LED3:** Flashes at regular intervals during fault-free operation. Irregular flashing means that the HF channel is probably disrupted. In this case, select an alternative channel.
- **LED4:** If this LED flashes, the HF channel is disrupted.
- **LED5 (Battery operation):** state of charge of the battery.

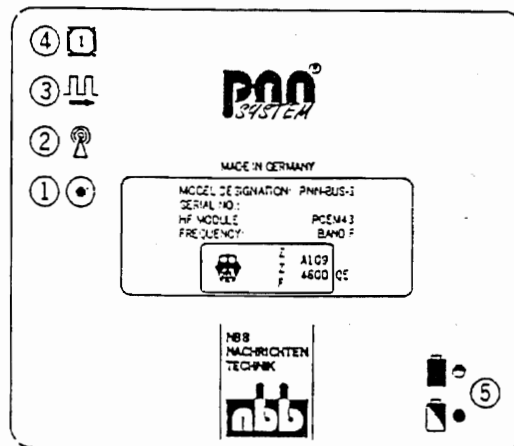

## 8. RATING PLATES

Rating plates contain the serial number, model designation, type of HF module and frequency. In the event of a query, please give the serial number without fail.

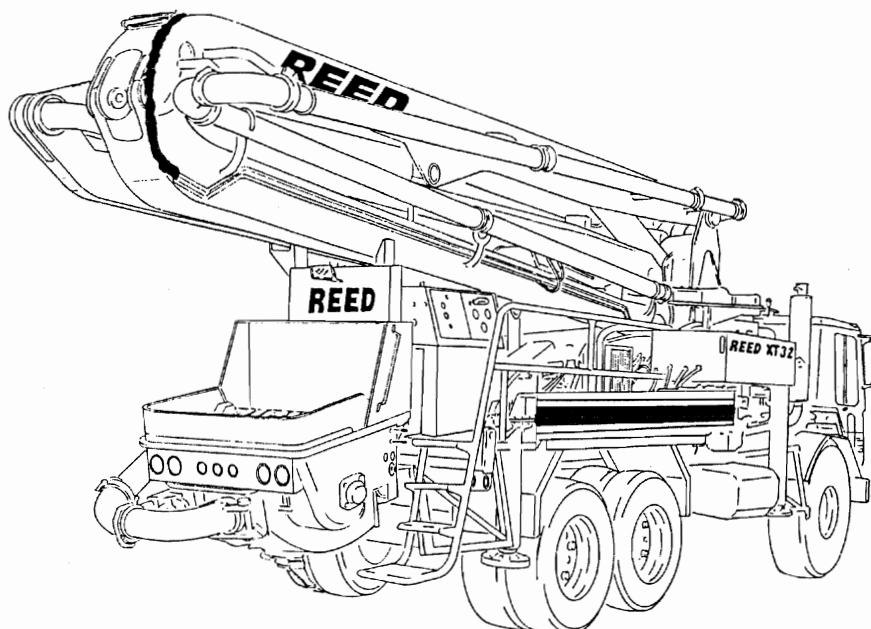
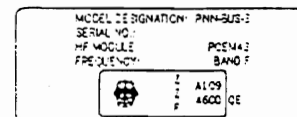

## 9. REGISTRATION

Explanatory notes on obtaining an operating permit for your NBB radio control system will be found in the accompanying registration documents.

## 10. MAINTENANCE

The NBB radio control unit is largely maintenance-free. Nevertheless, please observe the following points:

- The EMERGENCY-OFF button must operate freely.
- Keep the unit clean of any contamination from building materials.
- If any electrical welding is carried out on the crane, disconnect the control cable from the receiver, otherwise the receiver electronics may be damaged.

## 11. GUARANTEE

All NBB radio control units (transmitter, receiver, battery charger) are guaranteed to operate satisfactorily for a period of six months from the date of sale. The terms of the guarantee include parts and labour. Transport costs are the buyer's responsibility. The following are excluded from the guarantee: wearing parts, relays and batteries. The guarantee does not cover damage, accidental damage, negligence, improper use, non-adherence to operating conditions, the non-observance of operating, testing and servicing instructions, or repairs or modifications to the unit not authorized by NBB.

NBB will not be liable for consequential damage. It reserves the right to effect repairs or replacements at its own discretion.

## 12. ACTION IN THE EVENT OF A FAULT

Do not continue to work with a defective NBB radio control unit. Even a minor defect in the first instance may eventually lead to a major fault!

Do not try to repair the NBB radio control unit yourself. In the event of a fault, please notify your dealer or contact us!

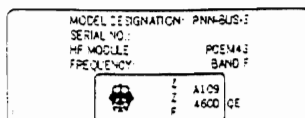
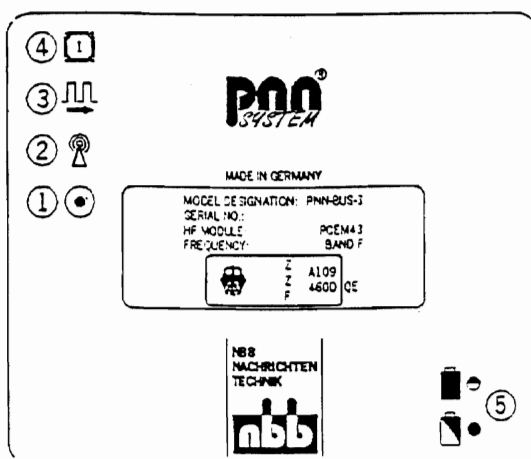

**NBB NANO-S-A2-HC  
RADIO REMOTE CONTROL**

**VENDR**

FIGURE 04  
PAGE 08

RECEIVER  
WIRING DIAGRAM

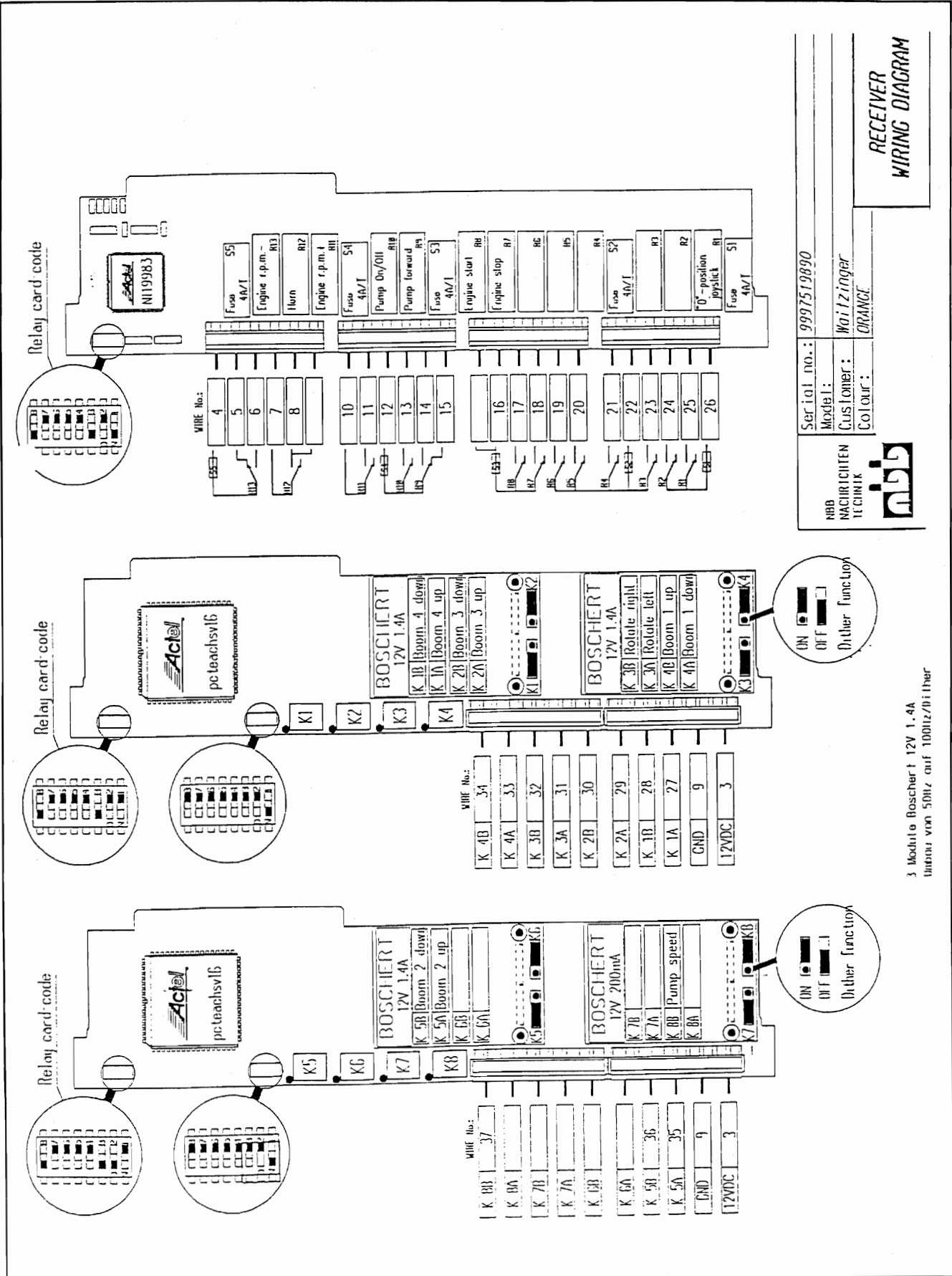

REVISION:

**NBB NANO-S-A2-HC  
RADIO REMOTE CONTROL**

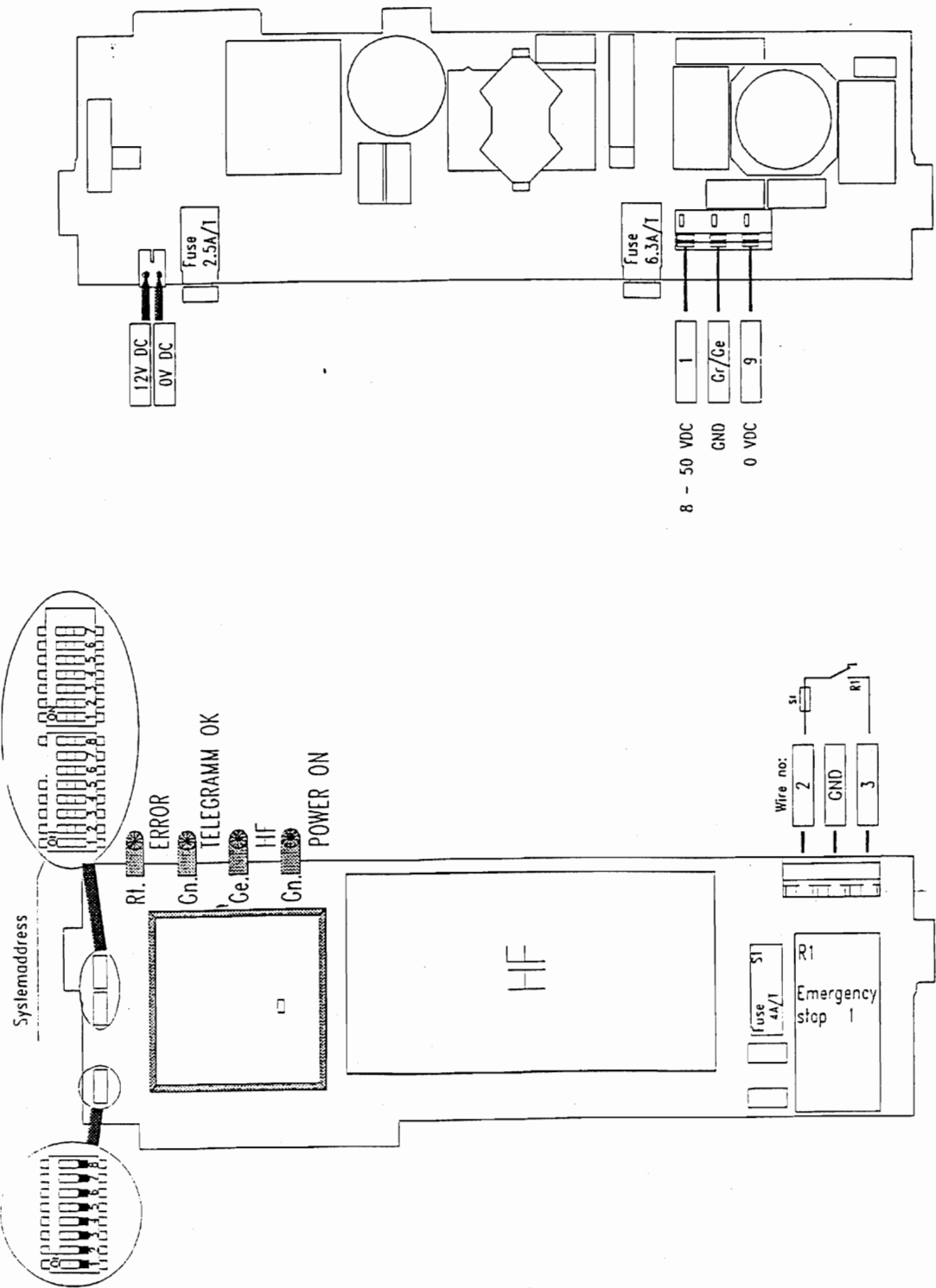

 <p>NBB NACHRICHTEN TECHNIK</p>	Serial no.:	9997519890	<p><b>RECEIVER WIRING DIAGRAM</b></p>
	Model:	Concrete-Pump	
	Customer:	Wolzinger	
	Colour:		
	Date:	7/05/1997	
	Name:		
Scale:			



# NBB NANO-S-A2-HC RADIO REMOTE CONTROL

VENDR

FIGURE 04  
PAGE 10

## CONTROL CABLE CONNECTING PLAN

Serial no. 9997519890  
Relay board code: 1. 3. 8

RECEIVER	Terminal strip no. :	CONTROL CABLE	Wire-No.:	CRANE
		Function:		Terminal strip or plug socket:
<div style="border: 1px solid black; padding: 2px; display: inline-block;">8-50VDC</div> <div style="border: 1px solid black; padding: 2px; display: inline-block;">12VDC</div>	1	Power supply 12VDC	1	> _____
	9	Power supply 0VDC GND	9	> _____
	2	Common	2	> _____
	3	Emergency stop	3	> _____
	4	Common	4	> _____
	5	Engine r.p.m. „-“	5	> _____
	6	Engine r.p.m. „-“	6	> _____
	7	Common	7	> _____
	8	Horn	8	> _____
	10	Common	10	> _____
	11	Engine r.p.m. +	11	> _____
	12	Common	12	> _____
	13	Pump on/off	13	> _____
	14	Pump for.	14	> _____
	15	Pump rev.	15	> _____
	16	Common	16	> _____
	17	Engine start	17	> _____
	18	Engine stop	18	> _____
	19		19	> _____
	20		20	> _____
	21		21	> _____
	22	Common	22	> _____
	23		23	> _____
	24		24	> _____
	25	„0“-position joystick	25	> _____
	26	Common	26	> _____

REVISION:

**REED**CONCRETE PLACING  
EQUIPMENT**NBB NANO-S-A2-HC  
RADIO REMOTE CONTROL****VENDR**FIGURE 04  
PAGE 11

Serial no.: 9997519890

Crane model:

Relay board code: 3, 8

**RECEIVER****CONTROL CABLE****CRANE**

Terminal strip no.:

Function:

Wire-No.:

Terminal strip  
or plug socket:

BOSCHERT

12V 1.4A

34 K4B: Boom 1 up 34

33 K4A: Boom 1 down 33

32 K3B: Rotate right 32

31 K3A: Rotate left 31

30 K2B: Boom 3 down 30

29 K2A: Boom 3 up 29

28 K1B: Boom 4 down 28

27 K1A: Boom 4 up 27

9 Gnd 9

3 12V DC 3

BOSCHERT

12V 1.4A

~~37~~ K8B: Pump speed (Poti) 37

— K8A: —

— K7B: —

~~36~~ K7A: —

— K6B: —

— K6A: —

36 K5B: Boom 2 down 36

35 K5A: Boom 2 up 35

9 Gnd 9

3 12V DC 3

BOSCHERT

12V 200mA

BOSCHERT

12V 1.4A

REVISION:

# TECHNICAL SUPPLEMENT

## NANO: Board E-AN04A2V1/1 TEACH-IN\*

DIL switch (SW2) for setting various transmission characteristics:

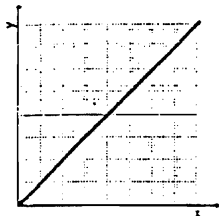

Setting for linear characteristic

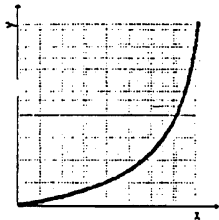

Setting for non-linear characteristic

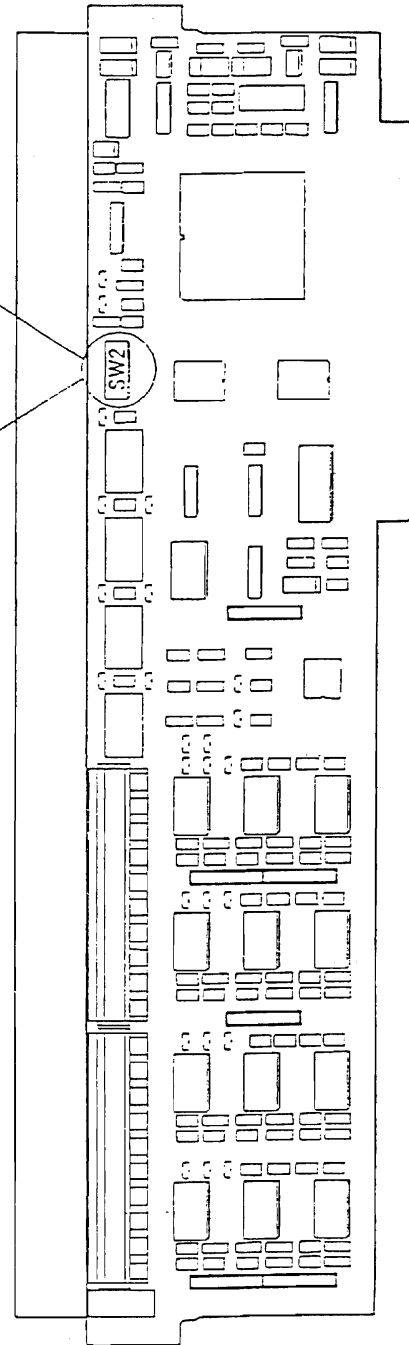
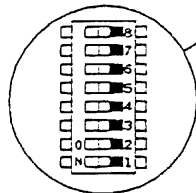
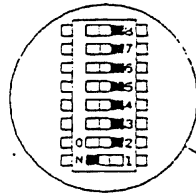

Characteristics  
linear or non-linear

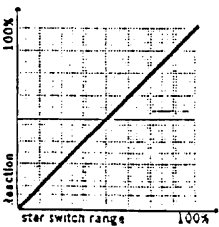

Characteristics in  
Teach-In mode

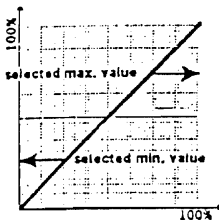

Characteristics after  
Teach-In mode

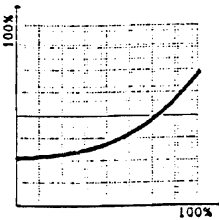
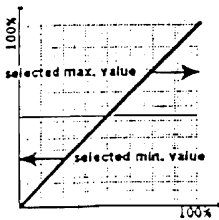
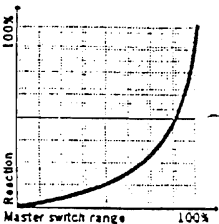
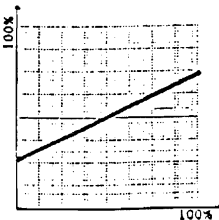

\*Please refer to the scope of supply of your facility.





# TECHNICAL DATA

**RECEIVER** *PNN-BUS-3 PNN-BUS-5*  
 Reception frequency range 400 - 477 MHz

Data security:  
 Generates a CRC code with a Hamming distance = 4. Generates a neutral position  
 Addressing of each transmitter with its own, unique combination  
 (32768 possible combinations). Parity - Bit parameters with addressing.

Data reception security:  
 2 diversitary evaluators (1 hardware evaluator, 1 software - controlled evaluator).  
 CRC. EMERGENCY OFF and neutral position bits. Restart inhibitor if EMERGENCY OFF  
 relay defective.

• contact loading for EMERGENCY OFF and commands.

max. switching voltage 250 V  
 max. switching current 6 A  
 max. switching power 1000 VA

	Weight	Size (L x W x H)
PNN-BUS-3	3,0 kg	30,6 x 18,1 x 13 cm
PNN-BUS-5	4,7 kg	36,4 x 28,3 x 15,2 cm

**BATTERY**  
 Pocket / Nano 7,2V / 0,6 Ah  
 MOL 9,6V / 0,6 Ah

**CHARGING UNIT**  
 Operating voltage 80V - 270V AC  
 8V - 50V DC

# SAUER SUNDSTRAND

## Series 90

### Contents

1. Introduction
  - 1.1 Use of This Manual
  - 1.2 Safety Precautions
2. Functional Description
  - 2.1 General Description and Cross Sectional Views
    - 2.1.1 Variable Displacement Pumps
  - 2.2 The System Circuit
  - 2.3 Common Features of Pumps and Motors
    - 2.3.1 End Caps and Shafts
    - 2.3.2 Speed Sensors
  - 2.4 Pump Features
    - 2.4.1 Charge Pump
    - 2.4.2 Charge Relief Valve
    - 2.4.3 Charge Check Valves
    - 2.4.4 Multi-Function Valves
    - 2.4.5 Pressure Limiter and High Pressure Relief Valves
    - 2.4.6 Bypass Valves
    - 2.4.7 Displacement Limiters
    - 2.4.8 Auxiliary Mounting Pads
    - 2.4.9 Filtration Options
    - 2.4.10 Pressure Override (POR) - 180 Frame Size Only
  - 2.5 Pump Control Options
    - 2.5.1 Manual Displacement Control (MDC)
    - 2.5.2 Hydraulic Displacement Control (HDC)
    - 2.5.3 Electric Displacement Control (EDC)
    - 2.5.4 Automotive Control (AC and AC II)
    - 2.5.5 3-Position (FNR) Electric Control
  - 2.6 Motor Features
    - 2.6.1 Motor Loop Flushing Valve and Charge Relief Valve
    - 2.6.2 Variable Motor Displacement Limiters
  - 2.7 Variable Motor Controls
    - 2.7.1 Hydraulic 2-Position Control
    - 2.7.2 Electric 2-Position Control
3. Technical Specifications
  - 3.1 General Specifications
  - 3.2 Circuit Diagrams
  - 3.3 Hydraulic Parameters
  - 3.4 Technical Data
4. Pressure Measurement
  - 4.1 Required Tools
  - 4.2 Port Locations and Pressure Gauge Installation
    - 4.2.1 Variable Pump
5. Initial Start-Up Procedure
6. Fluid and Filter Maintenance
7. Troubleshooting
  - 7.1 "Neutral" Difficult or Impossible to Find
  - 7.2 System Operating Hot
  - 7.3 Transmission Operates Normally in One Direction Only
  - 7.4 System Will Not Operate in Either Direction
  - 7.5 Low Motor Output Torque
  - 7.6 Improper Motor Output Speed
  - 7.7 Excessive Noise and/or Vibration
  - 7.8 System Response is Sluggish

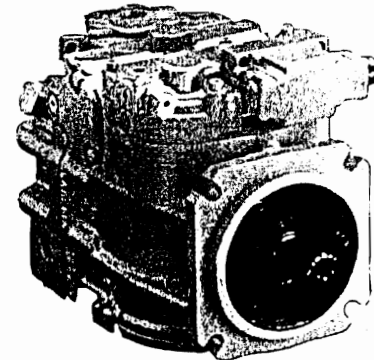
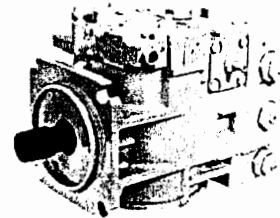



Series 90 Introduction 1

# 1. Introduction

## 1.1 Use of This Manual

This manual includes information for the normal operation, maintenance, and servicing of the Series 90 family of hydrostatic pumps and motors. The manual includes the description of the units and their individual components, troubleshooting information, adjustment instructions, and minor repair procedures. Unit warranty obligations should not be affected if maintenance, adjustment, and minor repairs are performed according to the procedures described in this manual.

Many service and adjustment activities can be performed without removing the unit from the vehicle or machine. However, adequate access to the unit must

be available, and the unit must be thoroughly cleaned before beginning maintenance, adjustment, or repair activities. Since dirt and contamination are the greatest enemies of any type of hydraulic equipment, cleanliness requirements must be strictly adhered to. This is especially important when changing the system filter and during adjustment and repair activities.

A worldwide network of Sauer-Sundstrand Authorized Service Centers is available should repairs be needed. Contact any Sauer-Sundstrand Authorized Service Center for details. A list of all Service Centers can be found in bulletin BLN-2-40527, or in brochure SAW (Ident. No. 698266).

## 1.2 Safety Precautions

Observe the following safety precautions when using and servicing hydrostatic products.

### Loss of Hydrostatic Braking Ability

**WARNING**  
When Series 90 units are used in vehicular hydrostatic drive systems, the loss of hydrostatic drive line power in any mode of operation (e.g. acceleration, deceleration or "neutral" mode) may cause a loss of hydrostatic braking capacity. A braking system which is independent of the hydrostatic transmission must, therefore, be provided which is adequate to stop and hold the system should the condition develop.

### Disable Work Function

**WARNING**  
Certain service procedures may require the vehicle/machine to be disabled (wheels raised off the ground, work function disconnected, etc.) while performing them in order to prevent injury to the technician and bystanders.

### Fluid Under High Pressure

**WARNING**  
Use caution when dealing with hydraulic fluid under pressure. Escaping hydraulic fluid under pressure can have sufficient force to penetrate your skin causing serious injury. This fluid may also be hot enough to burn. Serious infection or reactions can develop if proper medical treatment is not administered immediately.

### Flammable Cleaning Solvents

**WARNING**  
Some cleaning solvents are flammable. To avoid possible fire, do not use cleaning solvents in an area where a source of ignition may be present.



Series 90 Functional Description 2

## 2. Functional Description

This section describes the operation of pumps, motors, and their various serviceable features. It is a useful reference for readers unfamiliar with the functioning of a specific system.

### 2.1 General Description and Cross Sectional Views

#### 2.1.1 Variable Displacement Pumps

The Variable Displacement Pump (PV) is designed to convert an input torque into hydraulic power. The input shaft turns the pump cylinder which contains a ring of pistons. The pistons run against a tilted plate, called the swashplate. This causes the pistons to compress the hydraulic fluid which imparts the input energy into the hydraulic fluid. The high pressure fluid is then ported out to provide power to a remote function.

The swashplate angle can be varied by the control piston. Altering the swashplate angle varies the displacement of fluid in a given revolution of the input shaft. A larger angle causes greater displacement which yields greater output torque for a given input. A smaller angle reduces the displacement per revolution and yields greater speed for a given input.

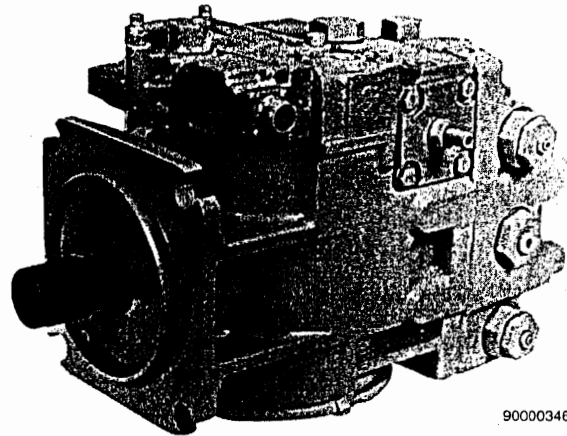

Series 90 Variable Displacement Pump (PV)

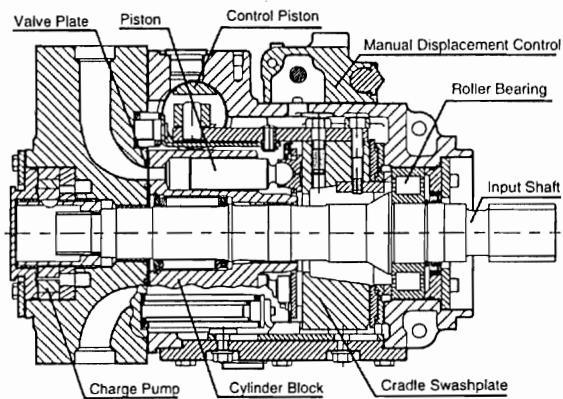

Series 90 PV Cross Section

90000346

90000189



**Series 90 Functional Description 2**

**2.2 The System Circuit**

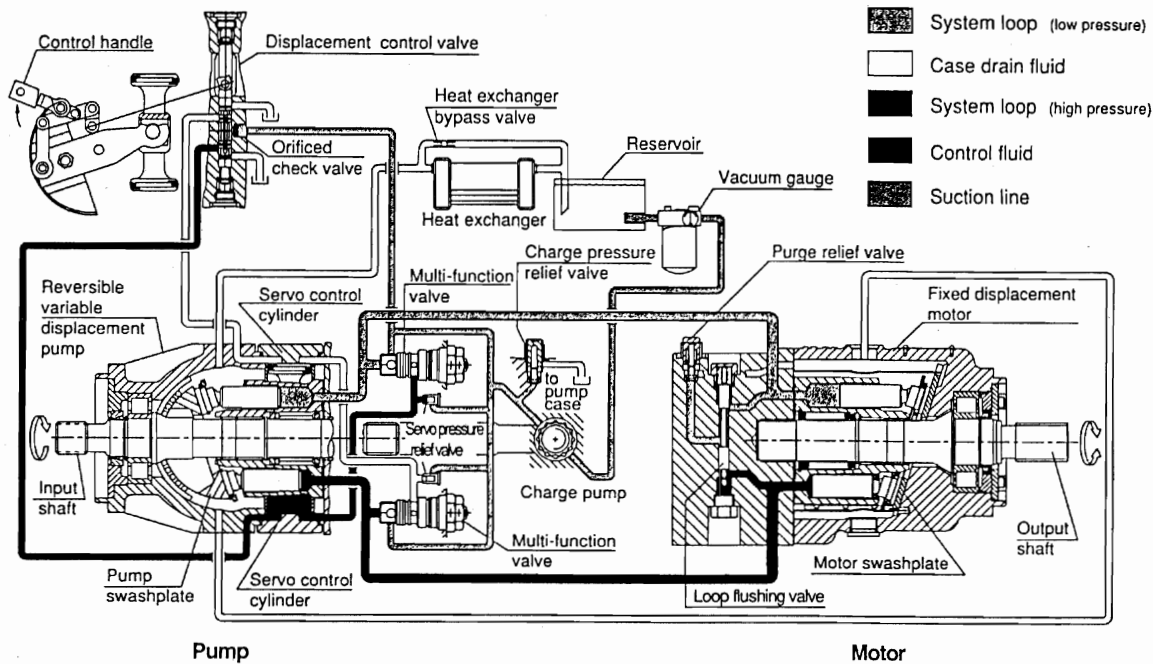

**Circuit Diagram for Series 90 PV and Series 90 MF**

90000800

**The Basic Closed Circuit**

The main ports of the pump are connected by hydraulic lines to the main ports of the motor. Fluid flows, in either direction, from the pump to the motor then back to the pump in this closed circuit. Either of the hydraulic lines can be under high pressure. The position of the pump swashplate determines which line is high pressure as well as the direction of fluid flow.

**Case Drain and Heat Exchanger**

The pump and motor require case drain lines to remove hot fluid from the system. The motor should be drained from its topmost drain port to ensure the case remains full of fluid. The motor case drain can then be connected to the lower drain port on the pump housing and out the top most port. A heat exchanger, with a bypass valve, is required to cool the case drain fluid before it returns to the reservoir.

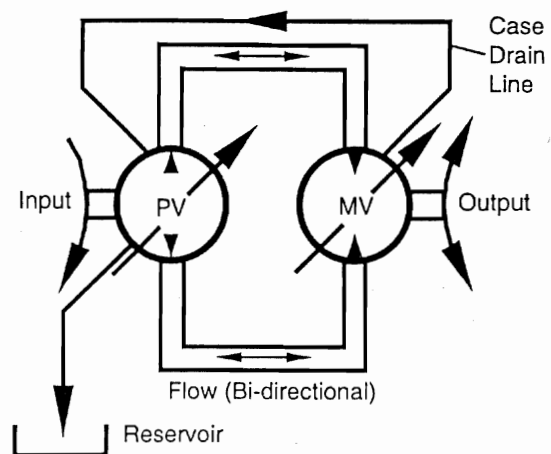

**Basic Closed Circuit**

90000803



**Series 90**

**Functional Description**

**2**

**2.3 Common Features of Pumps and Motors**

**2.3.1 End Caps and Shafts**

Series 90 pumps and motors can be supplied with a variety of end caps and shafts to allow for almost any configuration. For pumps, end caps are available with system ports on either side ("side ports") or both ports on one side ("twin ports"). Motors have end caps with ports on the face of the end cap ("axial ports") or both ports on one side ("twin ports"). See the Series 90 Technical Information manuals (BLN-10029 and BLN-10030) or the Series 90 Price Book (BLN-2-40588) for information on available options. **Removing the end cap will void the warranty on a Series 90 pump or motor.**

**2.3.2 Speed Sensors**

An optional speed sensor can be installed on Series 90 pumps and motors to provide unit speed information. The sensor reads a magnetic ring wrapped about the unit's cylinder. See Sec. 4 to locate the speed sensor port. See Sec. 8.4 and 9.6 to adjust and install the sensor.



90000810

Speed Sensor

**Series 90****Functional Description****2****2.4 Pump Features****2.4.1 Charge Pump**

The charge pump is necessary to supply cool fluid to the system, to maintain positive pressure in the main system loop, to provide pressure to operate the control system, and to make up for internal leakage. Charge pressure must be at its specified pressure under all conditions of driving and braking to prevent damage to the transmission.

The charge pump is a fixed-displacement, gerotor type pump installed in the variable displacement pump and driven off the main pump shaft. Charge pressure is limited by a relief valve (Sec. 2.4.2).

The standard charge pump will be satisfactory for most applications. However, if the charge pump sizes available for the given main pump size are not adequate, a gear pump may be mounted to the auxiliary mounting pad (Sec. 2.4.8) and supply the required additional charge flow. For repairs to the charge pump see Sec. 9.2.4.

**2.4.2 Charge Relief Valve**

The charge relief valve on the pump serves to maintain charge pressure at a designated level. A direct-acting poppet valve relieves charge pressure whenever it surpasses a certain level. This level is nominally set referencing case pressure at 1775 rpm. This nominal setting assumes the pump is in neutral (zero flow); in forward or reverse charge pressure will be lower. The charge relief valve setting is specified on the model code of the pump (Sec. 8.1.1). For repairs to the pump charge relief valve see Sec. 9.2.3.

**2.4.3 System Check Valves**

The system check valves allow pressurized flow from the charge pump to enter the low pressure side of the loop whenever system pressure dips below a certain level. This is needed as the pump will generally lose system pressure due to leakage and other factors. Since the pump can operate in either direction, two system check valves are used to direct the charge supply into the low pressure lines. The system check valves are poppet valves located in the multi-function valve assembly (next section).

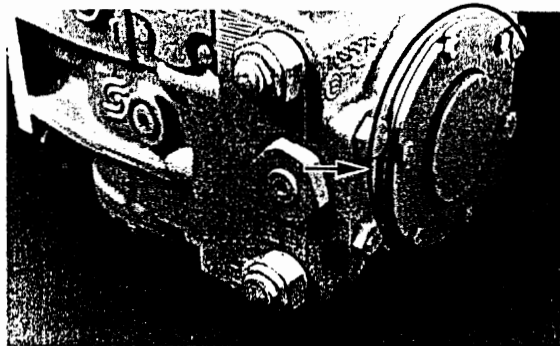

PV with Charge Pump

90000243

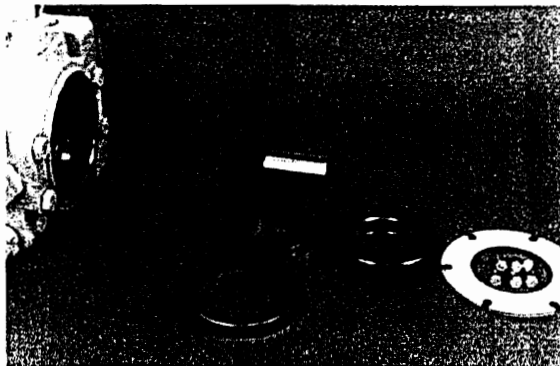

Charge Pump Components

90000349

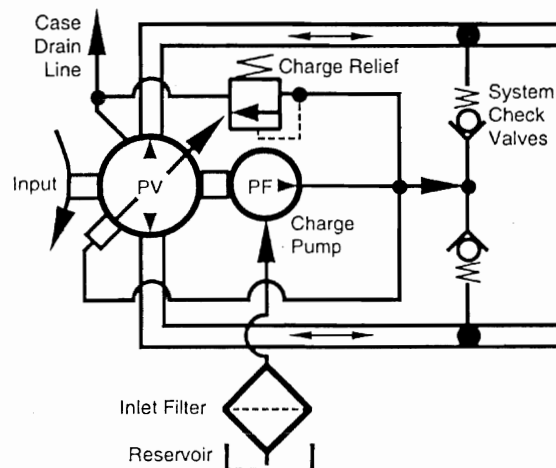

Pump Charge System

90000804



Series 90

Functional Description

2

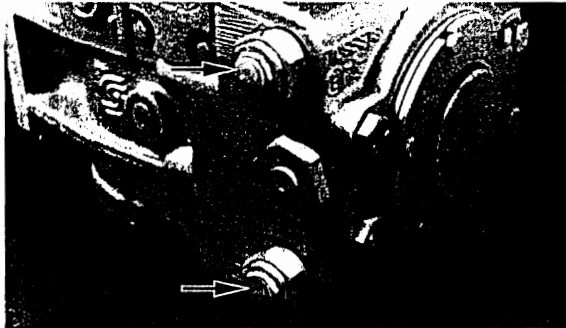

90000243

PV showing location of Multi-Function Valves

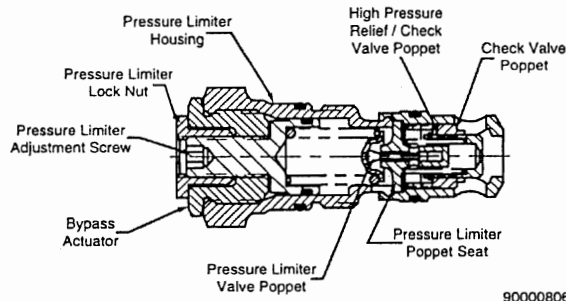

90000806

Cross Section of Multi-Function Valve

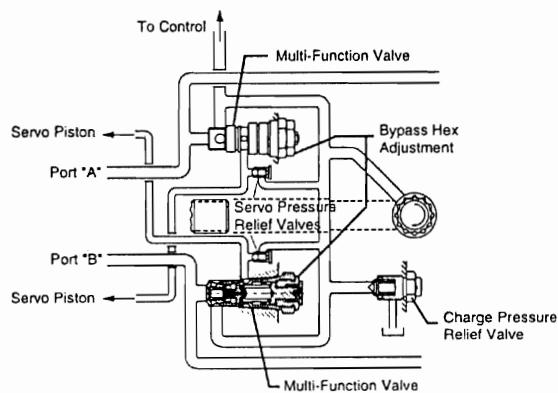

90000801

Circuit Diagram Showing Pressure Control Mechanisms

### 2.4.4 Multi-Function Valves

All Series 90 pumps include two multi-function valves. The multi-function valve incorporates the system check valve, the pressure limiter valve, the high pressure relief valve, and the bypass valve in a replaceable cartridge. These functions are described separately. There are two multi-function valve cartridges in each Series 90 pump to handle functions in either direction. See Secs. 8.1.2 and 9.2.1 for adjustments and repairs.

*NOTE: Some multi-function valves do not include a pressure limiter valve.*

### 2.4.5 Pressure Limiter and High Pressure Relief Valves

Series 90 pumps are designed with a sequenced pressure limiting system and high pressure relief valves. When the preset pressure is reached, the pressure limiter system acts to rapidly destroke the pump so as to limit the system pressure. For unusually rapid load application, the high pressure relief valve acts to immediately limit system pressure by cross-porting system flow to the low pressure side of the loop. The pressure limiter valve acts as the pilot for the high pressure relief valve spool. The high pressure relief valve is sequenced to operate at approximately 35 bar (500 psi) above the level that initiates the pressure limiter valve.

Both the pressure limiter sensing valves and relief valves are built into the multi-function valves (see above).

*NOTE: For some applications, such as dual path vehicles, the pressure limiter function may be defeated so that only the high pressure relief valve function remains.*

### 2.4.6 Bypass Valves

The bypass valves ("tow") can be operated when it is desired to move the vehicle or mechanical function when the pump is not running. The valve is opened by manually resetting the valve position (Sec. 8.1.3).

The bypass valves are built into the multi-function valves (see above).





**Series 90 Functional Description 2**

**2.4.7 Displacement Limiters**

Series 90 pumps sizes 042 - 250 are designed for optional mechanical displacement (stroke) limiters. The maximum displacement of the pump can be limited in either direction.

The setting can be set as low as 0° in either direction.

For instructions on adjustment see Sec. 8.1.5.

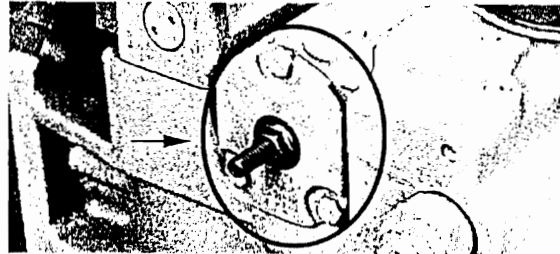

PV with Displacement Limiters

**2.4.8 Auxiliary Mounting Pads**

Auxiliary mounting pads are available on all Series 90 pumps. SAE A through E and H mounts are available (availability varies by pump size). This pad is used for mounting auxiliary hydraulic pumps and for mounting additional Series 90 pumps to make tandem pumps. The pads allow for full through-torque capability.



PV with Auxiliary Mounting Pad

**2.4.9 Filtration Options**

All Series 90 pumps are available with provisions for either suction or charge pressure filtration (integral or remote mounted) to filter the fluid entering the charge circuit. (See Sec. 6 for more information.)

**Suction Filtration**

The suction filter is placed in the circuit between the reservoir and the inlet to the charge pump. When suction filtration is used, a reducer fitting is placed in the charge pressure gauge port (M3). Filtration devices of this type are provided by the user.

**Charge Pressure Filtration**

The pressure filter may be integrally mounted directly on the pump or a filter may be remotely mounted for ease of servicing.

A 200 mesh screen, located in the reservoir or the charge inlet line, is recommended when using this filtration option. A non-bypass filter is preferred on all types of filtration.

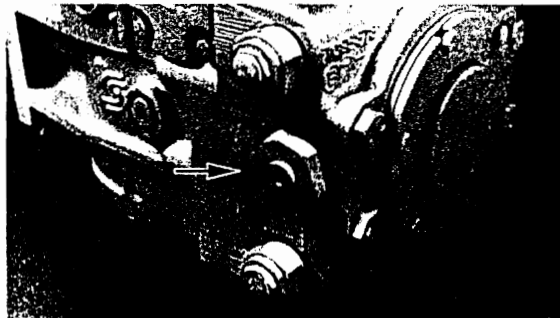

PV with Suction Filtration  
(No filtration device attached)

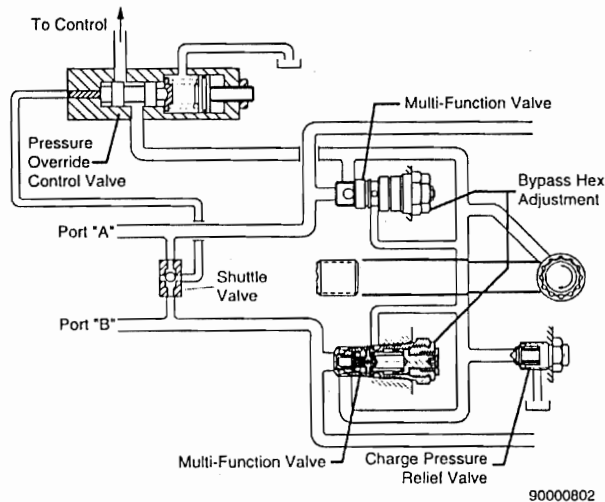

PV with Integral Charge Pressure Filtration (left)  
PV with Remote Charge Pressure Filtration (right,  
filter attached remotely)

**SAUER SUNDSTRAND****Series 90****Functional Description****2****Pressure Override - 180 Frame Size Only****2.4.10 Pressure Override (POR) - 180  
Frame Size Only**

The pressure override valve (POR) modulates the control pressure to the displacement control to maintain a pump displacement which will produce a system pressure level less than or equal to the POR setting. For unusually rapid load application, the high pressure relief valve function of the multifunction valves is available to also limit the pressure level.

The pressure override consists of a three-way normally open valve which operates in series with the pump displacement control. Control supply pressure is normally ported through the pressure override valve to the displacement control valve for controlling the pump's displacement. If the system demands a pressure above the override setting, the POR valve will override the control by reducing the control pressure supplied to the displacement control. As the control pressure reduces, the internal forces tending to rotate the swashplate overcome the force of the servo pistons and allow the pump's displacement to decrease.

**Series 90 Functional Description 2**

**2.5 Pump Control Options**

**2.5.1 Manual Displacement Control (MDC)**

The manual displacement control converts a mechanical input signal to a hydraulic signal using a spring-centered four-way servo valve. This valve ports hydraulic pressure to either side of a dual-acting servo piston. The servo piston rotates the cradle swashplate through an angular rotation of  $\pm 17^\circ$ , thus varying the pump's displacement from full displacement in one direction to full displacement in the opposite direction. The MDC is designed so the angular position of the pump swashplate is proportional to the rotation of the control input shaft. For adjustments see 8.2.1; for repairs see 9.3.2, 9.3.8.

**Non-Linear MDC**

The non-linear manual displacement control (photo in Sec. 8.2.2) operates in the same manner as the regular MDC except that it is designed so the change in the angular position of the pump swashplate *progressively* increases as the control input shaft is rotated toward its maximum displacement position. For adjustments see Sec. 8.2.2; for repairs see 9.3.2.

**Solenoid Override Valve**

A solenoid override valve option (not shown here) is available for MDC. This safety feature will return the swashplate to zero displacement position when activated. The valve may be set in either a normally open or normally closed mode. For repairs see 9.3.3, 9.3.4.

**Neutral Start Switch (NSS)**

The neutral start switch is an optional feature available with MDC. When connected properly with the vehicle's electrical system, the neutral start switch ensures that the prime mover can be started only when the control is in a neutral position. For adjustments see Sec. 8.2.3.

**2.5.2 Hydraulic Displacement Control (HDC)**

The hydraulic displacement control uses a hydraulic input signal to operate a spring-centered four-way servo valve. This valve ports hydraulic pressure to either side of a dual-acting servo piston. The servo piston rotates the cradle swashplate through an angular rotation of  $\pm 17^\circ$ , thus varying the pump's displacement from full displacement in one direction to full displacement in the opposite direction. The HDC is designed so the angular position of the pump swashplate is proportional to input pressure. For adjustments see 8.2.4; for repairs see 9.3.5, 9.3.8.

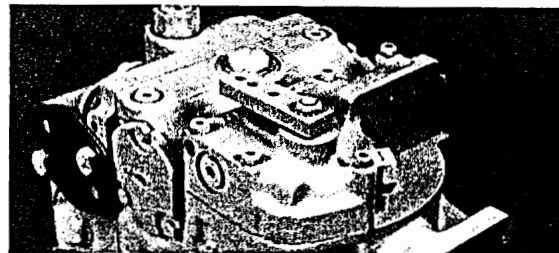

90000237

**PV with Manual Displacement Control**

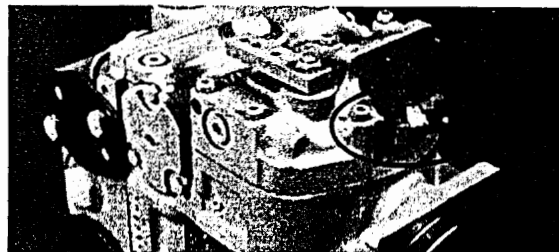

90000239

**PV with Manual Displacement Control and Neutral Start Switch**



90000240

**PV with Hydraulic Displacement Control**

**SAUER  SUNDSTRAND****Series 90****Functional Description****2**

90000241

PV with Electric Displacement Control

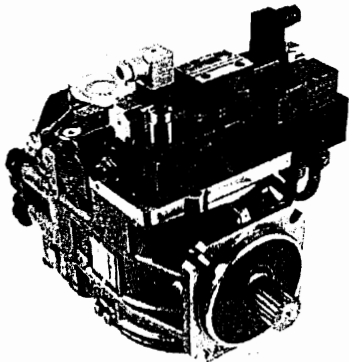

90000353

PV with Automotive Control (AC)

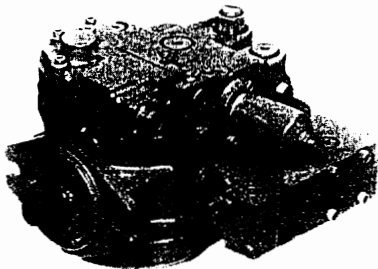

F000645

PV with Automotive Control Type II (AC II)

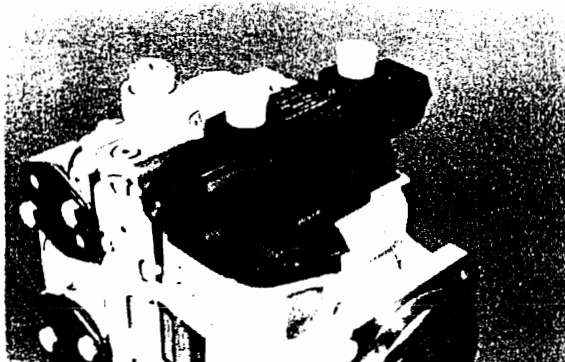

90000354

PV with 3-Position (FNR) Electric Control

**2.5.3 Electric Displacement Control (EDC)**

The electric displacement control is similar to the hydraulic displacement control with the input signal pressure controlled by a pressure control pilot (PCP) valve. The PCP valve converts a DC electrical input signal to a hydraulic signal which operates a spring-centered four-way servo valve. This valve ports hydraulic pressure to either side of a dual-acting servo piston. The servo piston rotates the cradle swashplate through an angular rotation of  $\pm 17^\circ$ , thus varying the pump's displacement from full displacement in one direction to full displacement in the opposite direction. The control is designed so the angular position of the swashplate is proportional to the EDC input. For neutral adjustment see Sec. 8.2.4; for repairs see Sec. 9.3.5, 9.3.6, and 9.3.8.

**2.5.4 Automotive Control (AC and AC II)**

Automotive Control (AC) allows a vehicle to be driven in a manner similar to an automobile with an automatic transmission.

The AC control includes a three-position electric control to provide direction control.

The AC II control can be combined with a manual, hydraulic, or electric displacement control to provide both direction control and control over maximum vehicle speed. It may also be combined with a 3-position electric control to provide direction control.

**2.5.5 3-Position (FNR) Electric Control**

This control utilizes a 12 or 24 VDC electrically operated spool valve to port pressure to either side of the pump displacement control piston. Energizing one of the solenoids will cause the pump to go to its maximum displacement in the corresponding direction.

All functions of the three-position (FNR) electric control are preset at the factory. For repairs, see Sec. 9.3.7.

**SAUER SUNDSTRAND****Series 90****Functional Description****2****2.6 Motor Features****2.6.1 Motor Loop Flushing Valve and Charge Relief Valve**

All Series 90 motors are designed to accommodate a loop flushing valve. The loop flushing valve is used in installations which require additional fluid to be removed from the main hydraulic circuit because of transmission cooling requirements, or unusual circuits requiring additional loop flushing to remove excessive contamination in the high pressure circuit.

A shuttle valve and charge relief valve are installed in the motor end cap to provide the loop flushing function. The shuttle valve provides a circuit between the low pressure side of the closed loop and the charge relief valve in the motor end cap.

The motor charge relief valve regulates the charge pressure level only when there is a pressure differential in the main loop. The shuttle valve is spring centered to the closed position so that no high pressure fluid is lost from the circuit when reversing pressures.

For charge relief valve adjustment see Sec. 8.3.1, for repairs see Sec. 9.4.1.

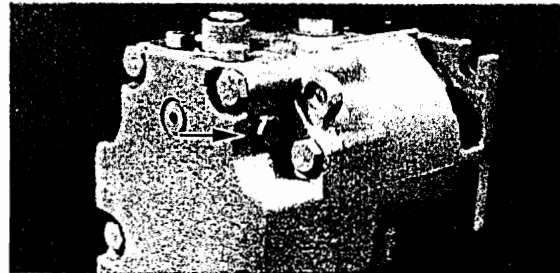

90000248

MF showing location of Loop Flushing Valve

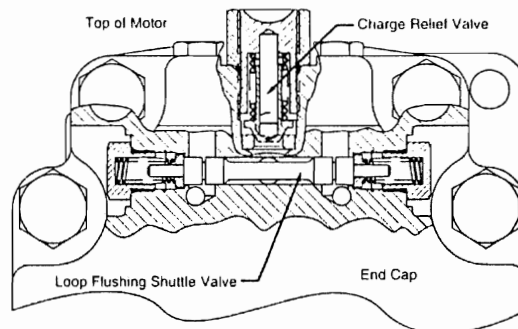

90000238

Motor Charge Relief Valve and Loop Flushing Shuttle Valve

**2.6.2 Variable Motor Displacement Limiters**

All Series 90 variable motors include mechanical displacement (stroke) limiters. Both the maximum and minimum displacement of the motor can be limited.

The range of the settings is as follows:

	055 MV Frame	075 MV Frame
Minimum Displacement	19 - 40 cm <sup>3</sup> 1.2 - 2.4 in <sup>3</sup>	26 - 54 cm <sup>3</sup> 1.6 - 3.3 in <sup>3</sup>
Maximum Displacement	65 - 100%	65 - 100%

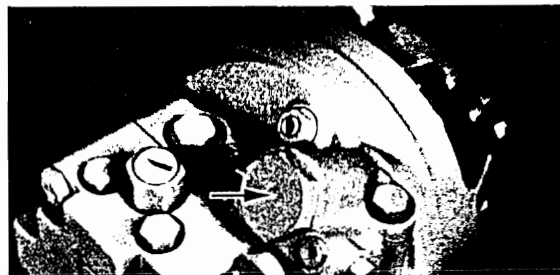

90000352

MV Maximum Displacement Limiter  
(Minimum Displacement Limiters on Opposite Side)

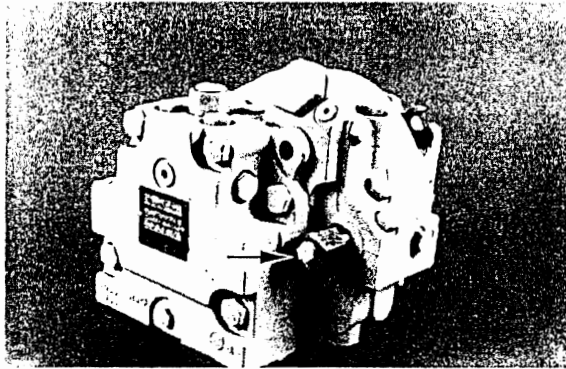
**SAUER  SUNDSTRAND****Series 90****Functional Description****2****2.7 Variable Motor Controls**

90000350

MV with Hydraulic 2-Position Control

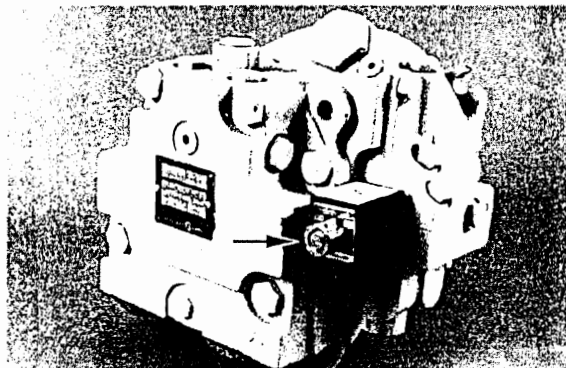

90000351

MV with Electric 2-Position Control

**2.7.1 Hydraulic 2-Position Control**

This control utilizes a hydraulically operated three-way hydraulic valve to port system pressure to either of the motor displacement control pistons. The motor is normally held at its maximum displacement. Supplying pilot hydraulic pressure to the valve will cause the motor to go to its minimum displacement.

All functions of the hydraulic two-position control are preset at the factory. For repairs see Sec. 9.5.2 and 9.5.4.

**2.7.2 Electric 2-Position Control**

This control utilizes an electric solenoid operated three-way hydraulic valve to port system pressure to either of the motor displacement control pistons. The motor is normally held at its maximum displacement. Energizing the solenoid will cause the motor to go to its minimum displacement.

All functions of the electric two-position control are preset at the factory. For repairs see Sec. 9.5.1 and 9.5.4.



Series 90

Technical Specifications

3

### 3. Technical Specifications

#### 3.1 General Specifications

**Design**

Variable Pumps and Motors: Axial piston pump of variable displacement, cradle swashplate design.

Fixed Motors: Axial piston motor with fixed displacement, fixed swashplate design.

**Type of Mounting** (per SAE J744)

SAE flange, Size "B" mounting pad, 2 bolts

SAE flange, Size "C" mounting pad, 4 bolts

Cartridge flange, 2 bolts (for motor only)

**Port Connections** (See Sec. 4.2 for exact specs.)

Main pressure ports: SAE flange, Code 62

Remaining ports: SAE straight thread O-ring boss

**Direction of Rotation**

Clockwise or counterclockwise (motors are bidirectional)

**Installation Position**

Installation position is discretionary. The housing must always be filled with hydraulic fluid, so note position of drain ports.

#### 3.2 Circuit Diagrams

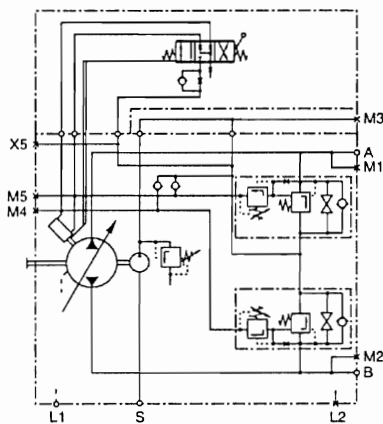

PV with charge pump and manual displacement control

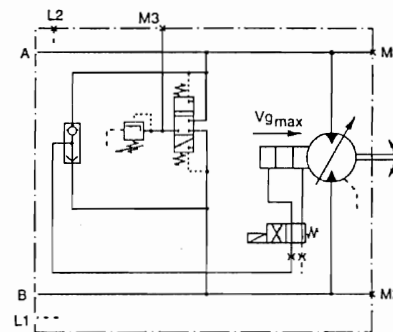

MV with electrohydraulic two-position control

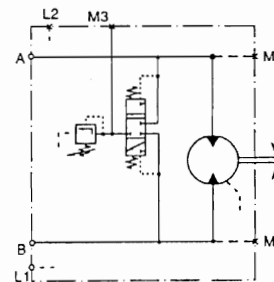

MF

**Series 90 Technical Specifications 3****3.3 Hydraulic Parameters****System Pressure Range**

Maximum Pressure	480 bar	[6960 psi]
Rated Pressure	420 bar	[6000 psi]

**Charge Pump Inlet Vacuum (on pumps only)**

Maximum Vacuum, Continuous	0.7 bar abs	[10 in Hg]
Maximum Vacuum, Cold Start	0.2 bar abs	[25 in Hg]

**Case Pressure**

Maximum, Continuous	3 bar	[44 psi]
Maximum, Intermittent or Cold Start	5 bar	[73 psi]

**Hydraulic Fluid**

Refer to SAS publication BLN 9887 or Publication SDF (Id. No. 697581). Also refer to publication ATI-E 9101 for information relating to biodegradable fluids

**Temperature Range<sup>1</sup>**

Minimum, Intermittent or Cold Start	-40°C	[-40°F]
Maximum, Continuous	104°C	[220°F]
Maximum, Intermittent	115°C	[240°F]

**Fluid Viscosity Limits**

Minimum, Intermittent	5 mm <sup>2</sup> /s	[42 SUS]
Minimum, Continuous	6.4 mm <sup>2</sup> /s	[47 SUS]
Minimum, Optimum	13 mm <sup>2</sup> /s	[70 SUS]
Maximum, Continuous	110 mm <sup>2</sup> /s	[510 SUS]
Maximum, Intermittent or Cold Start	1600 mm <sup>2</sup> /s	[7400 SUS]

**Filtration**

Required cleanliness level: ISO 4406 Class 18/13 or better. Refer to SAS publications BLN 9887 or Publication SDF (Id. No. 697581) and ATI-E 9201.





## Series 90 Technical Specifications 3

### 3.4 Technical Data

**Table 1 - Variable Displacement Pumps**

	Dimension	030 PV	042 PV	055 PV	075 PV	100 PV	130 PV	180 PV	250 PV
Displacement (maximum)	cm <sup>3</sup>	30.0	42.0	55.0	75.0	100.0	130.0	180.0	250.0
	in <sup>3</sup>	1.83	2.56	3.35	4.57	6.10	7.93	10.98	15.25
Minimum speed	min <sup>-1</sup> (rpm)	500	500	500	500	500	500	500	500
Rated speed*	min <sup>-1</sup> (rpm)	4200	4200	3900	3600	3300	3100	2600	2300
Maximum speed*	min <sup>-1</sup> (rpm)	4600	4600	4250	3950	3650	3400	2850	2500
Max. attainable speed* at max. disp.	min <sup>-1</sup> (rpm)	5000	5000	4700	4300	4000	3700	3150	2750
Theoretical torque at max. disp.	Nm / bar	0.48	0.67	0.88	1.19	1.59	2.07	2.87	3.97
	lbf•in/1000 psi	290	380	530	730	970	1260	1750	2433
Weight (Base Unit)	kg	28	34	40	49	68	88	136	154
	lb	62	75	88	108	150	195	300	340

**Table 2 - Fixed and Variable Displacement Motors**

	Dimension	030 MF	042 MF	055 MF	075 MF	100 MF	130 MF	055 MV	075 MV	
Displacement (maximum)	cm <sup>3</sup>	30.0	42.0	55.0	75.0	100.0	130.0	55.0	75.0	
	in <sup>3</sup>	1.83	2.56	3.35	4.57	6.10	7.93	3.35	4.57	
Displacement (minimum)	cm <sup>3</sup> in <sup>3</sup>	—	—	—	—	—	—	19.0 1.16	26.0 1.59	
Rated speed*	at max. disp.	min <sup>-1</sup> (rpm)	4200	4200	3900	3600	3300	3100	3900	3600
	at min. disp.	min <sup>-1</sup> (rpm)	—	—	—	—	—	—	4600	4250
Maximum speed*	at max. disp.	min <sup>-1</sup> (rpm)	4600	4600	4250	3950	3650	3400	4250	3950
	at min. disp.	min <sup>-1</sup> (rpm)	—	—	—	—	—	—	5100	4700
Max. attainable speed* at max. disp.	min <sup>-1</sup> (rpm)	5000	5000	4700	4300	4000	3700	4700	4300	
Theoretical torque at max. disp.	Nm / bar	0.48	0.67	0.88	1.19	1.59	2.07	0.88	1.19	
	lbf•in/1000 psi	290	380	530	730	970	1260	530	730	
Maximum flow at max. disp.	l / min	138	193	234	296	365	442	234	296	
	gal / min	36.5	51	62	78	96	117	62	78	
Max. corner power	kW	111	155	187	237	292	354	224	282	
	hp	149	208	251	318	392	475	300	378	
Weight (SAE Flange)	kg	11	15	20	26	34	45	39	44	
	lb	24	34	45	57	74	99	86	98	
Weight (Cartridge Motor)	kg	—	17	26	33	—	—	40	46	
	lb	—	37	57	72	—	—	88	101	

\* = Refer to Series 90 Technical Information manual for definitions



**Series 90**

**Pressure Measurement**

**4**

**4. Pressure Measurement**

**4.1 Required Tools**

The service procedures described in this manual for Series 90 pumps and motors can be performed using common mechanic's tools. Special tools, if required are shown.

Pressure gauges should be calibrated frequently to ensure accuracy. Snubbers are recommended to protect pressure gauges.

**4.2 Port Locations and Pressure Gauge Installation**

The following sections list the ports for each type of hydraulic unit. The recommended pressure gauge and fitting are also specified.

Outline drawings showing port locations follow the tables.

**4.2.1 Variable Pump**

Port	Function	Recommended Gauge Size and Fitting
M1	System Pressure Port "A"	1000 bar or 10 000 psi Gauge 9/16—18 O-Ring Fitting
M2	System Pressure Port "B"	1000 bar or 10 000 psi Gauge 9/16—18 O-Ring Fitting
M3 (M6)	Charge Pressure	50 bar or 1000 psi Gauge 9/16—18 O-Ring Fitting
M4 M5	Servo Pressure	50 bar or 500 psi Gauge 9/16—18 O-Ring Fitting

Port	Function	Recommended Gauge Size and Fitting
L1 L2	Case Pressure	10 bar or 100 psi Gauge SAE O-Ring Fitting: 030, 042 7/8—14 055, 075, 100 1-1/16—12 130 1-5/16—12 180, 250 1-5/8—12
X1 X2	HDC / EDC Pressure	50 bar or 1000 psi Gauge 7/16 — 20 O-Ring Fitting or 9/16 — 18 O-Ring Fitting
X3	Ext. Control Pressure	50 bar or 1000 psi Gauge 9/16 — 18 O-Ring Fitting
S	Charge Pump Inlet	Vacuum Gauge, Tee into Inlet Line SAE O-Ring Fitting: 030, 042 1-1/16 — 12 055, 075 1-5/16 — 12 100, 130, 180 1-5/8 — 12 250 1-1/2 SAE Split Flange



**Series 90 Pressure Measurement 4**

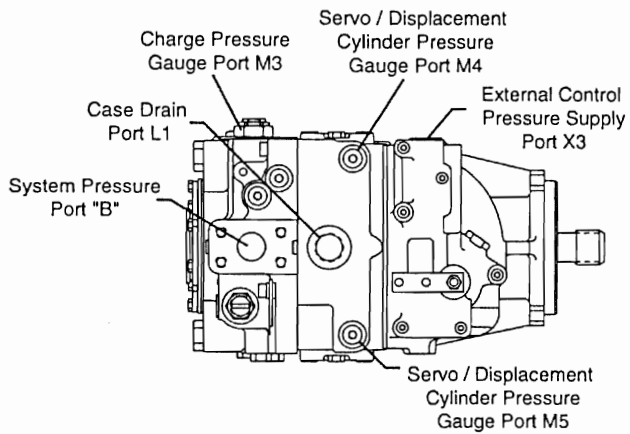

Top View

90000814

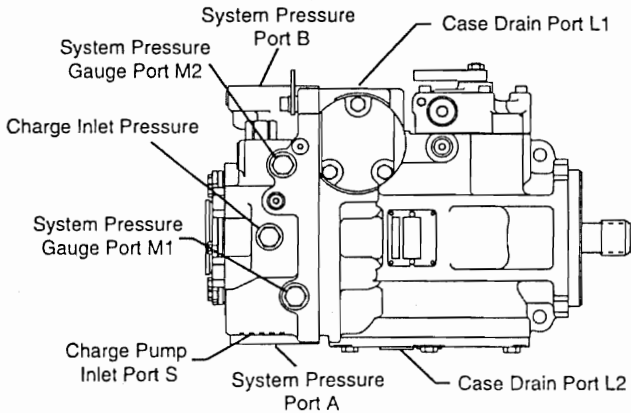

Left Side View

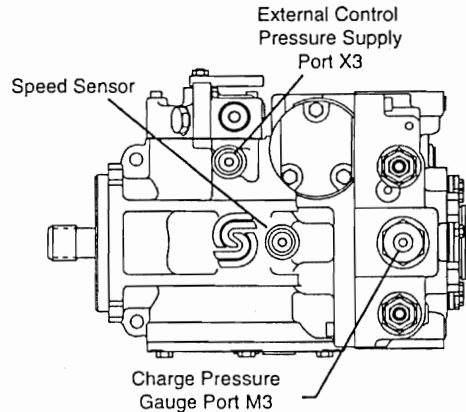

Right Side View

90000815  
90000816

PV with Side Port End Cap and Manual Displacement Control

**SAUER  SUNDSTRAND****Series 90****Start-Up****5**

## 5. Initial Start-Up Procedure

The following start-up procedure should always be followed when starting-up a new Series 90 installation or when restarting an installation in which either the pump or motor had been removed.

**WARNING**

The following procedure may require the vehicle/machine to be disabled (wheels raised off the ground, work function disconnected, etc.) while performing the procedure in order to prevent injury to the technician and bystanders. Take necessary safety precautions before moving the vehicle/machine.

Prior to installing the pump and/or motor, inspect the units for damage incurred during shipping and handling. Make certain all system components (reservoir, hoses, valves, fittings, heat exchanger, etc.) are clean prior to filling with fluid.

Fill the reservoir with recommended hydraulic fluid. This fluid should be passed through a 10 micron (nominal, no bypass) filter prior to entering the reservoir. The use of contaminated fluid will cause damage to the components, which may result in unexpected vehicle/machine movement. See the publications BLN-9887 and SDF 697581 for further related information.

The inlet line leading from the reservoir to the pump must be filled prior to start-up. Check inlet line for properly tightened fittings and make sure it is free of restrictions and air leaks.

**Be certain to fill the pump and/or motor housing with clean hydraulic fluid prior to start up.** Fill the housing by pouring filtered oil into the upper case drain port.

Install a 50 bar (or 1000 psi) pressure gauge in the charge pressure gauge port (see Sec. 4.2 for location) to monitor the charge pressure during start-up.

It is recommended that the external control input signal (linkage for MDC, hydraulic lines for HDC, or

electrical connections for EDC) be disconnected at the pump control until after initial start-up. This will ensure that the pump remains in its neutral position.

**WARNING**

Do not start prime mover unless pump is in neutral position (0° swashplate angle). Take precautions to prevent machine movement in case pump is actuated during initial start up.

“Jog” or slowly rotate prime mover until charge pressure starts to rise. Start the prime mover and run at the lowest possible RPM until charge pressure has been established. Excess air may be bled from the high pressure lines through the high pressure system gauge port.

Once charge pressure has been established, increase speed to normal operating RPM. Charge pressure should be as indicated in the pump model code (see Sec. 8.1.1). If charge pressure is inadequate, shut down and determine cause for improper pressure. Refer to Troubleshooting Sec. 7.

**WARNING**

Inadequate charge pressure will affect the operator's ability to control the machine.

Shut down the prime mover and connect the external control input signal. Also reconnect the machine function if disconnected earlier. Start the prime mover, checking to be certain the pump remains in neutral. With the prime mover at normal operating speed, slowly check for forward and reverse machine operation.

Charge pressure may slightly decrease during forward or reverse operation. Continue to cycle slowly between forward and reverse for at least five minutes.

Shut down prime mover, remove gauges, and plug ports. Check reservoir level and add filtered fluid if needed.

The transmission is now ready for operation.



Series 90

Fluid and Filter Maintenance

6

### 6. Fluid and Filter Maintenance

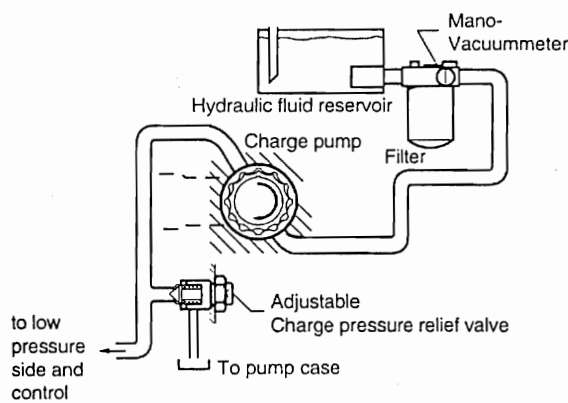

P000797 E

Suction Filtration Schematic

To ensure optimum service life of Series 90 products, regular maintenance of the fluid and filter must be performed. Contaminated fluid is the main cause of unit failure. Care should be taken to maintain fluid cleanliness while performing any service procedure.

Check the reservoir daily for proper fluid level, the presence of water (noted by a cloudy to milky appearance, or free water in bottom of reservoir), and rancid fluid odor (indicating excessive heat). If either of these conditions occur, change the fluid and filter immediately.

It is recommended that the fluid and filter be changed per the vehicle/machine manufacturer's recommendations or at the following intervals:

System with a sealed-type reservoir	2000 hours
System with a breathing-type reservoir	500 hours

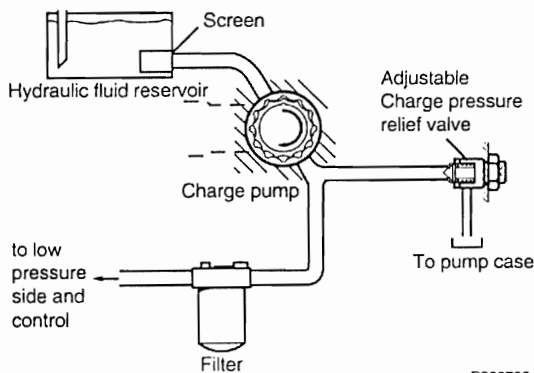

P000798 E

Charge Pressure Filtration Schematic  
(Partial Flow)

It may be necessary to change the fluid more frequently than the above intervals if the fluid becomes contaminated with foreign matter (dirt, water, grease, etc.) or if the fluid has been subjected to temperature levels greater than the recommended maximum. Never reuse fluid.

The filter should be changed whenever the fluid is changed or whenever the filter indicator shows that it is necessary to change the filter.

Filters can be in either pressure filtration or suction filtration configurations. For suction filtration, filters should have a Beta-ratio of  $\beta_{10} > 2$ . For charge pressure filtration, filters should have a Beta-ratio of  $\beta_{10} > 10$ . See Sauer-Sundstrand publication BLN-9887 or 697581 and ATI-E 9201 for more information on filtration.

## Series 90

## Troubleshooting

7

## 7. Troubleshooting

This section provides general steps to follow if certain undesirable system conditions are observed. Follow the steps in a section until the problem is solved. Some of the items will be system specific. For areas covered in this manual, a section is referenced. **Always observe the safety precautions listed in Sec. 1.2 and related to your specific equipment.**

### 7.1 "Neutral" Difficult or Impossible to Find

Item	Description	Action
1. Check input to pump control.	Input to control module is operating improperly.	Check control input and repair or replace as necessary.
2. Check pump displacement control.	Control linkages are not secure, control orifices are blocked, etc.	Adjust, repair, or replace control module as necessary (8.2 and 9.3).
3. Repair or replace pump.		Consult a Sauer-Sundstrand Authorized Service Center.

### 7.2 System Operating Hot

Item	Description	Action
1. Check oil level in reservoir.	Insufficient hydraulic fluid will not meet cooling demands of system.	Fill reservoir to proper level.
2. Inspect heat exchanger.	Heat exchanger not sufficiently cooling the system.	Check air flow and input air temperature for heat exchanger. Clean, repair or replace heat exchanger.
3. Check charge pressure.	Low charge pressure will overwork system.	Measure charge pressure (4.2). Inspect and adjust or replace charge relief valve (8.1.1 and 9.2.3). Or repair leaky charge pump (9.2.4).
4. Check charge pump inlet vacuum.	High inlet vacuum will overwork system. A dirty filter will increase the inlet vacuum. Inadequate line size will restrict flow.	Check charge inlet vacuum (4.2). If high, inspect inlet filter and replace as necessary. Check for adequate line size, length or other restrictions.
5. Check system relief pressure settings.	If the system relief settings are too low, the relief valves will be overworked.	Verify settings of pressure limiters and high pressure relief valves and adjust or replace multi-function valves as necessary (8.1.2, 9.2.1)
6. Check for internal leakage in motor.	Leakage will reduce low side system pressure and overwork the system.	Monitor motor case flow without loop flushing in the circuit (use defeat spool 9.4.1.3). If flow is excessive, replace motor.
7. Check system pressure.	High system pressure will overheat system.	Measure system pressure (4.2). If pressure is high reduce loads.
8. Replace transmission.		Replace pump and motor.

**Series 90****Troubleshooting****7****7.3 Transmission Operates Normally in One Direction Only**

Item	Description	Action
1. Check input to pump control.	Input to control module is operating improperly.	Check control input and repair or replace as necessary.
2. Check pump displacement control.	Control linkages are not secure, control orifices are blocked, etc.	Repair or replace control module as necessary (8.2 and 9.3).
3. Interchange system pressure limiters, high pressure relief valves, and system check valves.	Interchanging the multi-function valves will show if the problem is related to the valve functions contained in the multi-function valves.	Interchange multi-function valves. If the problem changes direction, repair or replace the valve on the side that does not operate (8.1.2 and 9.2.1).
4. Check charge pressure.	If charge pressure decays in one direction the loop flushing valve may be "sticking" in one direction.	Measure charge pressure in forward and reverse (4.2). If pressure decays in one direction, inspect and repair the motor loop flushing valve (9.4.1.1).

**7.4 System Will Not Operate in Either Direction**

Item	Description	Action
1. Check oil level in reservoir.	Insufficient hydraulic fluid to supply system loop.	Fill reservoir to proper level.
2. Check input to pump control.	Input to control module is operating improperly.	Check control input and repair or replace as necessary.
3. Check pump displacement control.	Control linkages are not secure, control orifices are blocked, etc.	Repair or replace control module as necessary (8.2 and 9.3).
4. Ensure bypass valve(s) are closed.	If bypass valve(s) is open, the system loop will be depressurized.	Close bypass valves (8.1.3). Replace multi-function valve if defective (9.2.1).
5. Check charge pressure with pump in neutral.	Low charge pressure insufficient to recharge system loop.	Measure charge pressure with the pump in neutral (4.2). If pressure is low, go to step 6; otherwise continue with step 5.
6. Check charge pressure with pump in stroke.	Low charge pressure with the pump in stroke indicates a motor charge relief valve or system pressure relief valve may be improperly set.	Measure charge pressure with pump in stroke (4.2). If pressure is low, adjust or replace motor charge relief valve (8.3.1 and 9.4.1.2), otherwise go to step 9.
7. Inspect pump charge relief valve.	A pump charge relief valve that is leaky or set too low will depressurize the system.	Adjust or replace pump charge relief valve as necessary (8.1.1, 9.2.3)
8. Check charge pump inlet filter.	A clogged filter will undersupply system loop.	Inspect filter and replace if necessary.



**Series 90 Troubleshooting 7**

- |   |   |   |
|---|---|---|
| 9. Check charge pump.                   | A malfunctioning charge pump will provide insufficient charge flow.   | Repair or replace the charge pump (9.2.4). If OK go to last step. |
| 10. Check pump displacement control.    | Control linkages are not secure, control orifices are blocked, etc.   | Repair or replace control module as necessary (8.2 and 9.3).      |
| 11. Check system pressure.              | Low system pressure will not provide power necessary to move load.    | Measure system pressure (4.2). Continue with next step.           |
| 12. Check system multi-function valves. | Defective multi-function valves will cause system pressure to be low. | Repair or replace multi-function valve(s) (9.2.1).                |
| 13. Replace transmission.               |   | Replace pump and motor.   |

**7.5 Low Motor Output Torque**

Item	Description	Action
1. Check system pressure at motor.	Low system pressure at the motor will reduce torque.	Measure system pressure at motor (4.2). If pressure limiter setting is low, increase setting.
2. Variable motor stuck at minimum displacement.	Minimum motor displacement yields low output torque.	Check control supply pressure (4.2.3) or repair displacement control (9.5). Check motor control orifices (9.5.4).
3. Check for internal leakage.	Internal leakage will reduce system pressure.	Check for leakage in O-rings, gaskets, and other fittings (9.1.1 and others). Repair unit as required, or replace leaky unit.
4. Replace transmission.		Replace pump and motor.

**7.6 Improper Motor Output Speed**

Item	Description	Action
1. Check oil level in reservoir.	Insufficient hydraulic fluid will reduce motor speed.	Fill oil to proper level.
2. Check charge pressure.	Incorrect charge pressure can result in a low speed motor.	Measure charge pressure (8.1.1), adjust charge system as necessary (9.2.3 and 9.2.4).
3. Check pump output flow.	Incorrect outflow will affect output speed. Incorrect output flow indicates the swashplate is out of position.	Measure pump output flow by teeing into outflow hose. Check for proper pump speed and see that the pump is in full stroke.
4. Check variable motor displacement control.	If variable motor displacement control is not functioning correctly, variable motor swashplate may be in wrong position.	See if variable motor displacement control is responding. If not, repair or replace control (9.5).



**Series 90****Troubleshooting****7****7.7 Excessive Noise and/or Vibration**

Item	Description	Action
1. Check oil in reservoir.	Insufficient hydraulic fluid will lead to cavitation.	Fill reservoir to proper level.
2. Air in system.	Air bubbles will lead to cavitation.	Look for foam in reservoir. Check for leaks on inlet side of system loop. Afterwards, let reservoir settle until bubbles are gone. Run system at low speed to move system fluid to reservoir. Repeat.
3. Check pump inlet vacuum.	High inlet vacuum will create noise. A dirty filter will increase the inlet vacuum.	Inspect and replace filter as necessary. Check for proper suction line size.
4. Inspect shaft couplings.	A loose shaft coupling will cause excessive noise.	Replace loose shaft coupling in charge pump (Sec. 9.2.4) or replace pump or motor.
5. Inspect shaft alignment.	Unaligned shafts will create excessive frictional noise.	Align shafts.

**7.8 System Response is Sluggish**

Item	Description	Action
1. Check oil level in reservoir.	Insufficient hydraulic fluid will reduce output pressure.	Fill reservoir to proper level.
2. Check multi-function valves' pressure settings.	Incorrect pressure settings will affect system reaction time.	Adjust or replace multi-function valves (8.1.2 and 9.2.1).
3. Check pump inlet vacuum.	High pump inlet vacuum will reduce system pressure.	Measure charge inlet vacuum (4.2). If high replace inlet filter.
4. Check prime mover speed.	Low engine speed will reduce system performance.	Adjust engine speed.
5. Check charge and control pressures.	Incorrect charge or control pressures will affect system performance.	Measure charge and control pressures and correct if necessary (4.2 and others).
6. Check system internal leakage.	Internal leakage will reduce system pressure.	Check for leakage in O-rings, gaskets, and other fittings (9.1.1 and others).
7. Replace transmission.		Replace pump and motor.

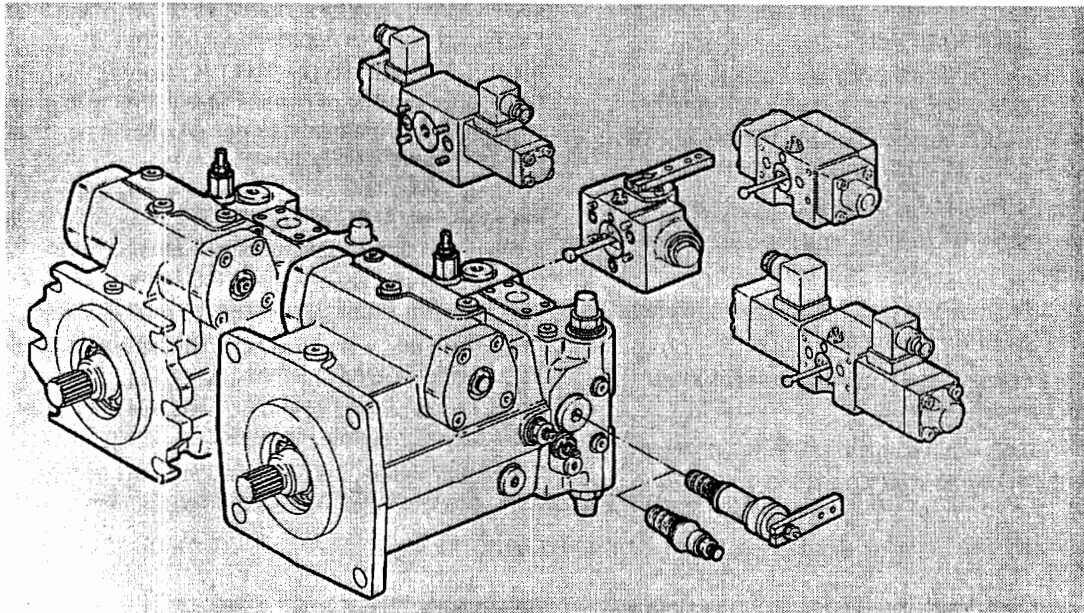
**NOTICE**

Specifications, descriptions and illustrative material shown herein were as accurate as known at the time this publication was approved for printing.

BRUENINGHAUS HYDROMATIK reserves the right to discontinue models or options at any time or to change specifications, materials, or design without notice and without incurring obligation.

Optional equipment and accessories may add cost to the basic unit, and some options are available only in combination with certain models or other options.

For the available combinations refer to the relevant data sheet for the basic unit and the desired option.

Adjustment and tests have to be carried out on the test bench under operating temperatures.

Protection of personnel and property has to be guaranteed by appropriate measures.

Expert knowledge, the precondition of any service work, can be obtained in our training courses.

**CONTENTS**

- General repair instructions
- Seal kits and sub assembly groups
- Sealing of the drive shaft
- Sealing of the boost pump
- Sealing of the control piston cover
- Sealing of the boost pressure valve
- Sealing of the pressure relief valve HD
- Sealing of the pressure cut-off valve
- Sealing of the control device
- Control device HW
- Control device HD
- Control device EP
- Control device DA
- Sealing of the regulator valve
- Pump disassembly
- Dismantling of the control
- Dismantling of the cylinder
- Inspection notes
- Positioning piston, rotary group assembly
- Installation of the rotary group
- Assembly of the pump
- Tightening torques
- Safety regulations
- Adjustment instructions



**Achtung!**  
Nachfolgend Hinweise bei allen Reparaturarbeiten  
an Hydraulikaggregaten beachten!

**Attention!**  
Observe the following notices when carrying out repair  
work at hydraulic aggregates!

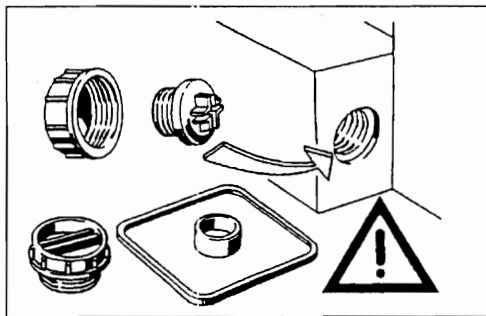

Alle Öffnungen der Hydraulikaggregate verschließen.

Close all ports of the hydraulic aggregates.

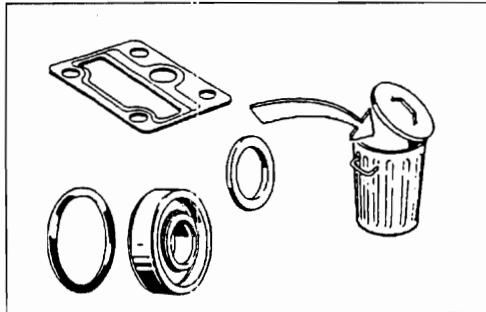

Alle Dichtungen erneuern.  
Nur original HYDROMATIK-Ersatzteile verwenden.

Replace all seals.  
Use only original HYDROMATIK spare parts.

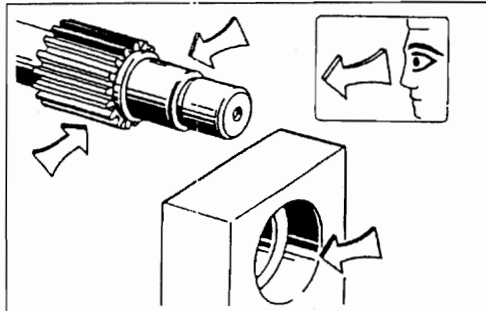

Alle Dicht- und Gleitflächen auf Verschleiß prüfen.  
Achtung: Nacharbeiten an Dichtflächen z. B. durch  
Schleifpapier kann die Oberfläche beschädigen.

Check all seal and sliding surfaces for wear.  
Attention: Rework of sealing area f. ex. with abrasive  
paper can damage surface.

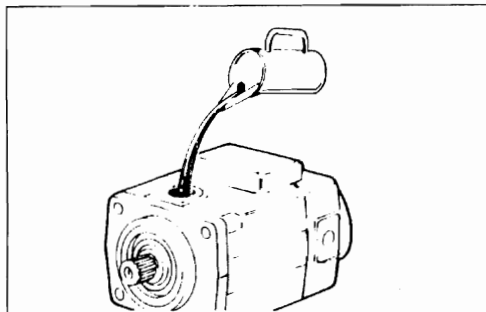

Hydraulikaggregate vor Inbetriebnahme mit  
Betriebsmedium befüllen.

Fill up hydraulic aggregates with medium  
before start- up.

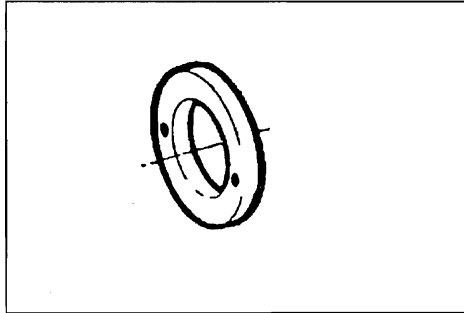

1 Dichtsatz für Triebwelle.

Seal kit for drive shaft.

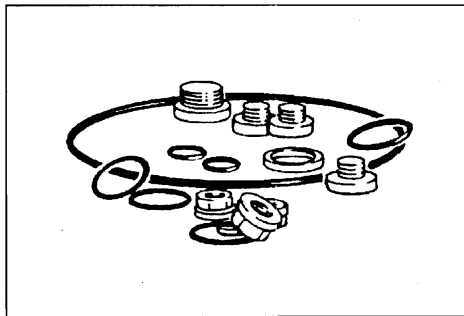

2 Äußerer Dichtsatz.

External seal kit.

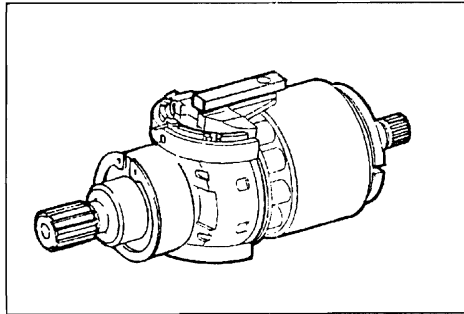

3 Triebwerk komplett.

Complete rotary group.

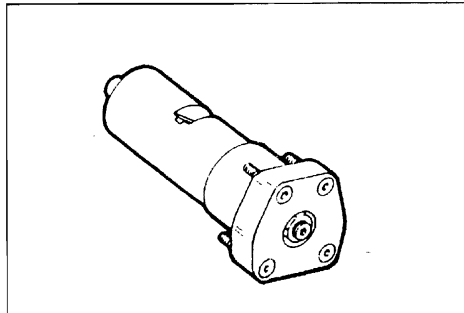

4 Stellkolben

Positioning piston

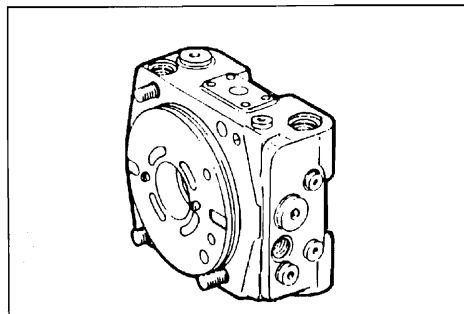

5 Anschlußplatte

Valve plate

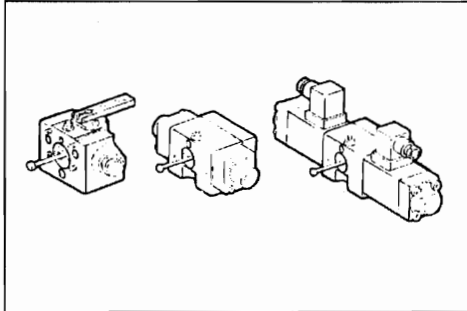

- 6 Ansteuergeräte HW, HD, EP  
Hinweis:  
NG 71 wie NG 40 - 56 mit Flachdichtung.  
Control device HW, HD, EP  
Note:  
Size 71 control device as size 40 - 56 with flat seal.

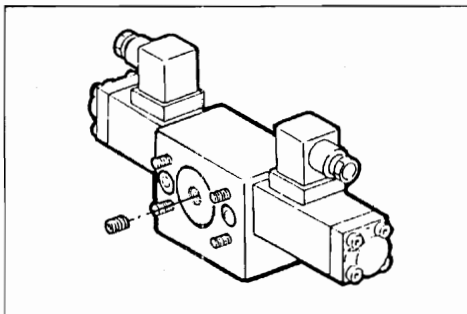

- 7 Ansteuergerät DA  
Hinweis:  
NG 71 wie NG 40 - 56 mit Flachdichtung.  
Control device DA  
Note:  
Size 71 control device as size 40 - 56 with flat seal.

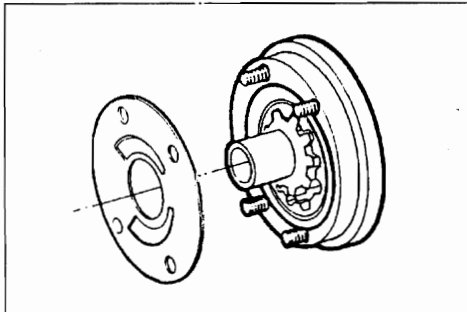

- 8 Hilfspumpe  
Boost pump

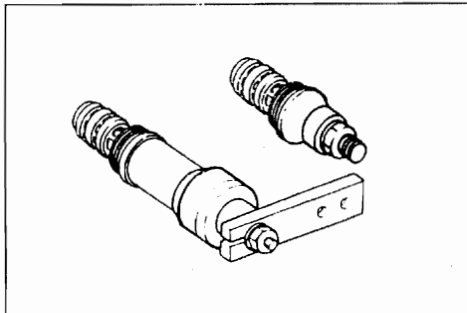

- 9 Regelventil  
Control valve

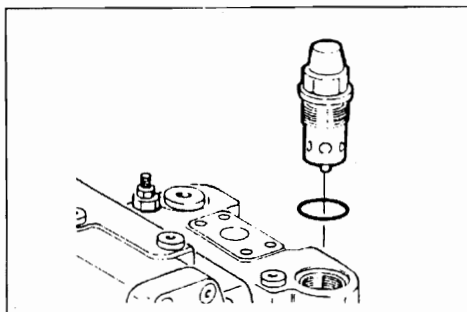

- 10 HD - Ventil  
High pressure valve

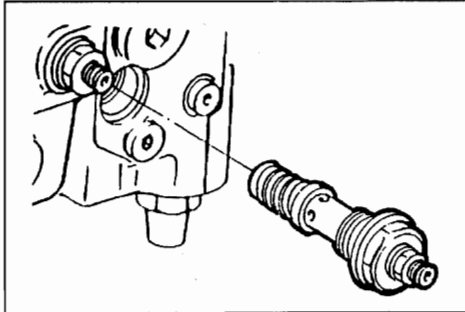

11 ND - Ventil  
Low pressure valve

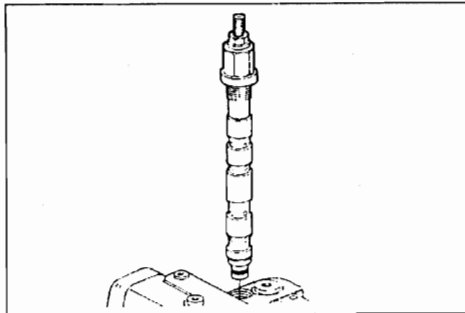

12 Druckabschneidung  
Pressure cut-off

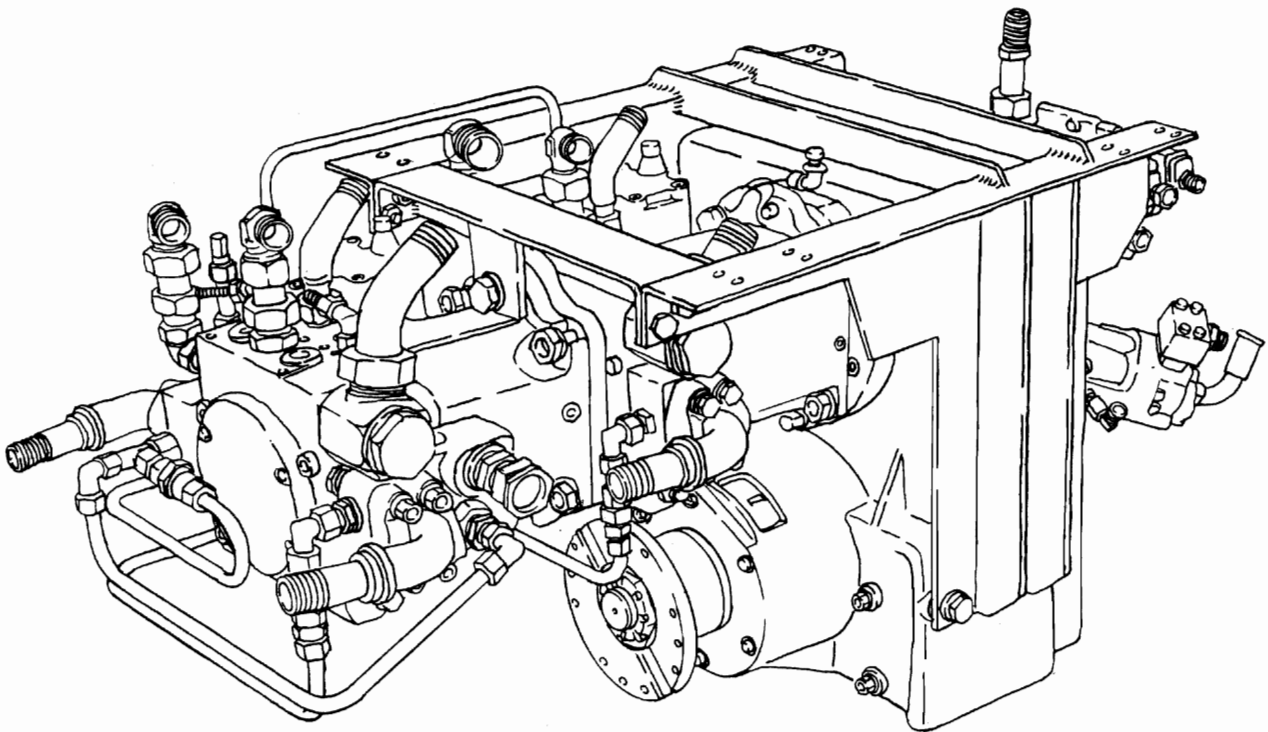

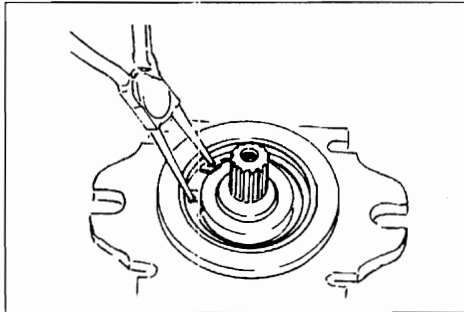
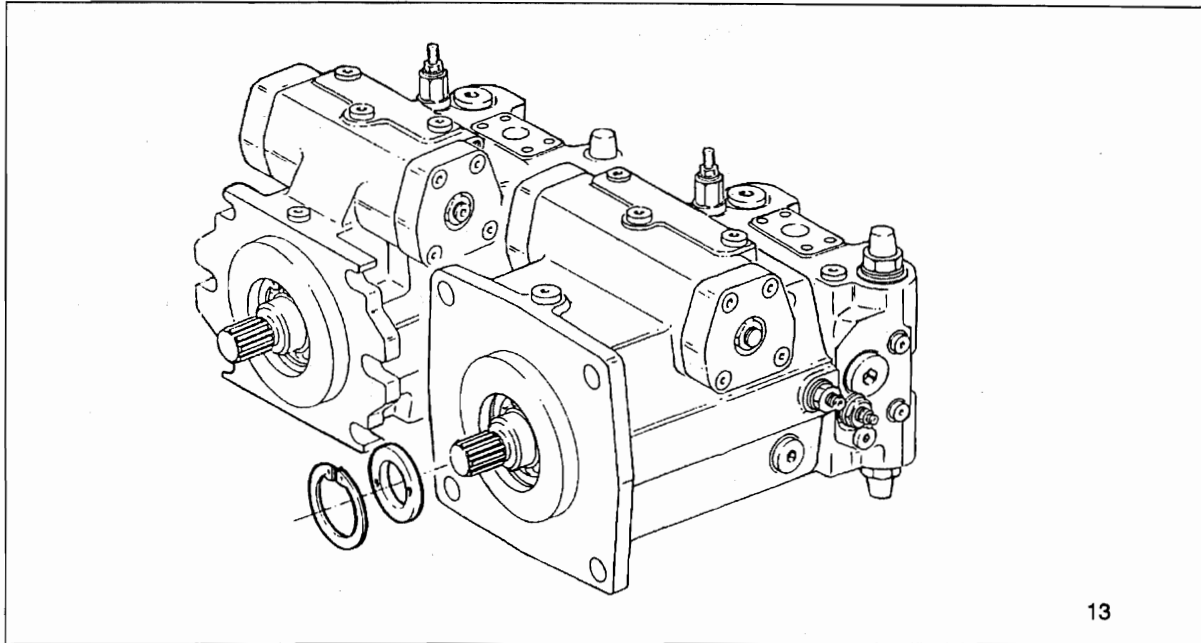

- 14 Triebwelle abkleben.  
Sicherungsring ausbauen.

Protecting the drive shaft.  
Remove retaining ring.

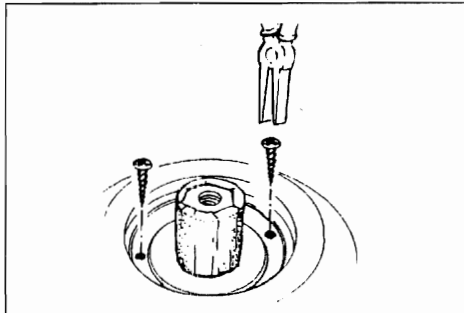

- 15 Blechschraube in die mit Gummi gefüllten  
Löcher eindrehen.  
Mit Zange WDR herausziehen.

Screw in sheet metal screw into the holes  
fitted with rubber.  
Pull out shaft seal with pliers.

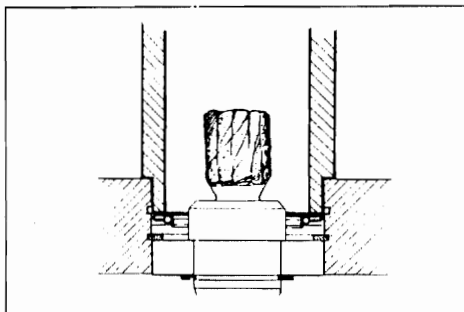

- 16 Wellendichtring mit Buchse auf  
Anschlag einpressen.  
Sicherungsring einbauen.

Press-in shaft seal with bush to stop.  
Assemble retaining ring.

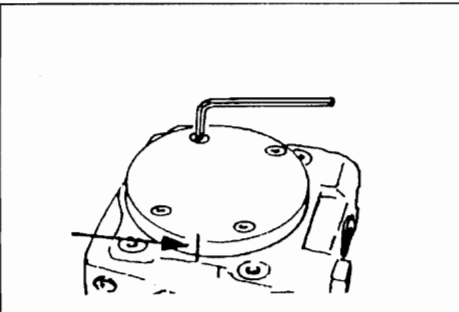
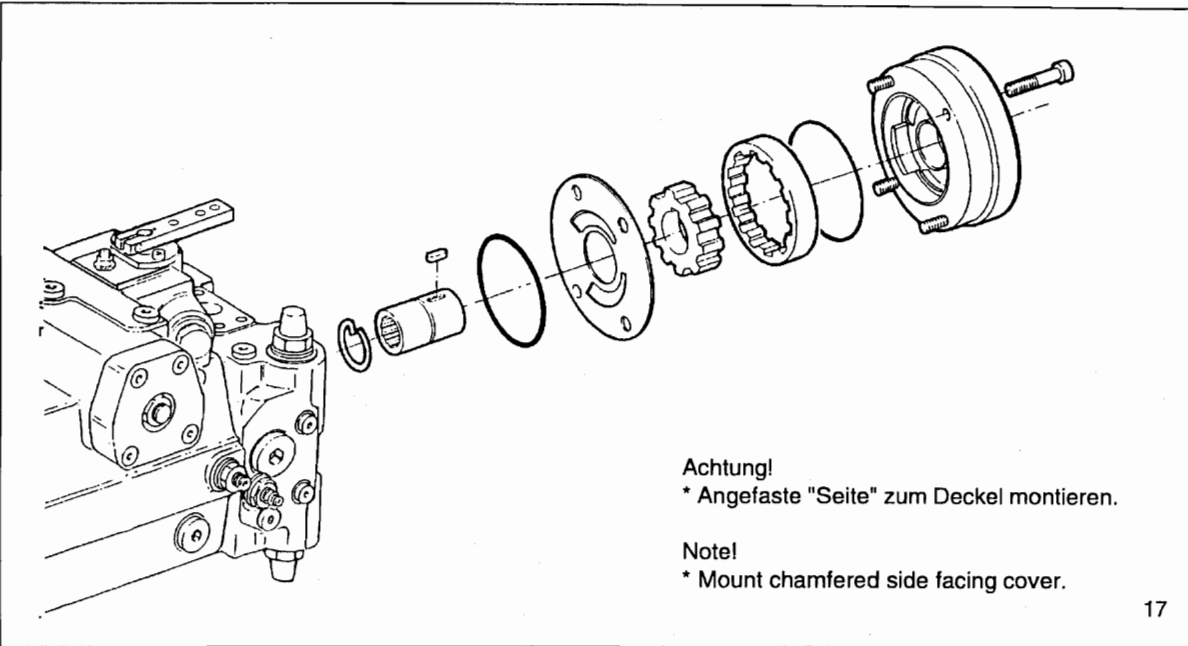

Lage kennzeichnen,  
Befestigungsschrauben ausbauen.

Mark position,  
remove fixing screws.

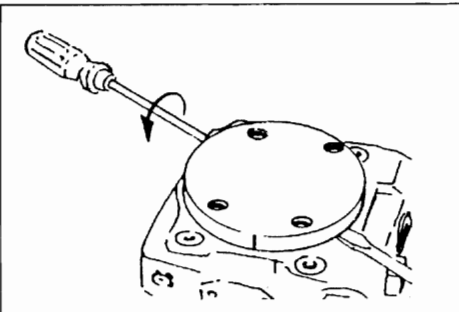

Deckel abdrücken.

Pry-off cover.

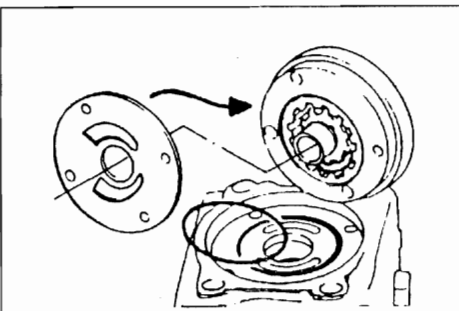

Kontrolle:  
O-Ring, Nut,  
Lauffläche, Anschlußplatte.

Check:  
O-ring, groove,  
gliding surface, connection plate.



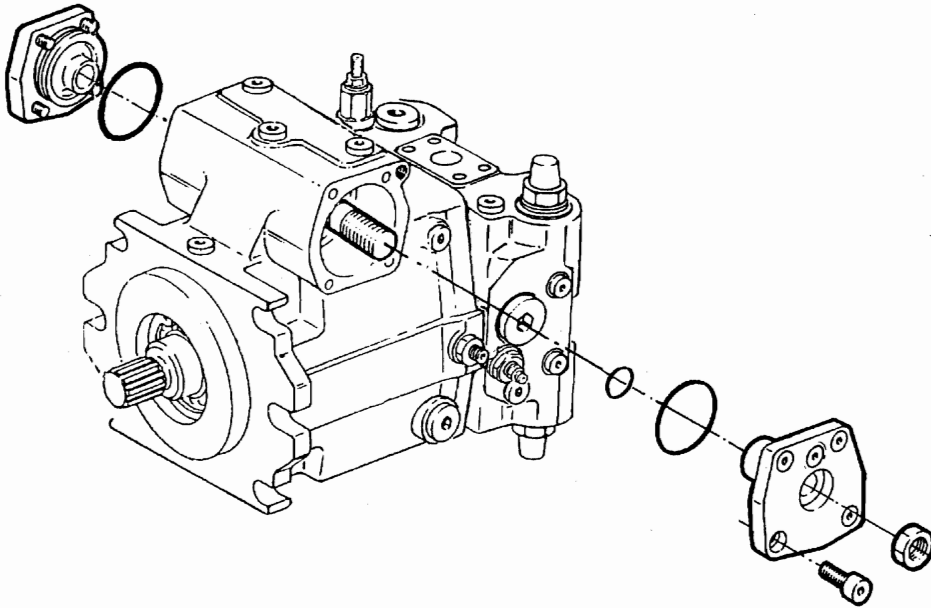

Achtung!  
Korrekt mechanische 0-Lageneinstellung überprüfen

Attention!  
Check correct mechanical 0-position.

21

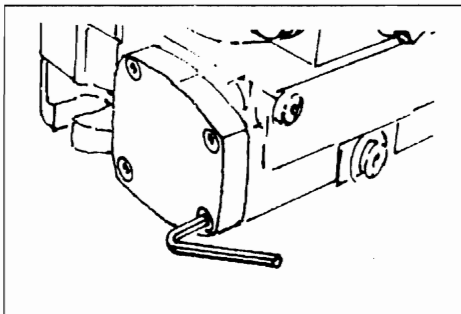

22 Lage kennzeichnen.

Mark position.

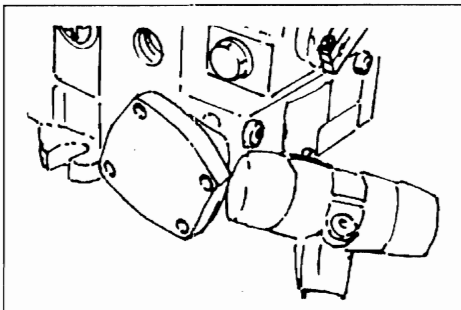

23 Deckel verdrehen und mit leichten Hammerschlägen lösen.

Rotate cover and release by tapping gently with hammer.

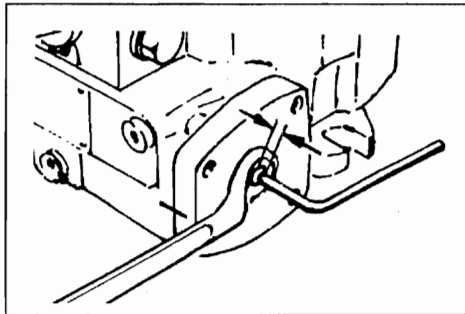

24 Deckel kennzeichnen. Maß festhalten, Kontermutter lösen, Stellschraube gegenhalten.

Mark cover. Must be fixed, loosen counter nut, hold adjustment screw.

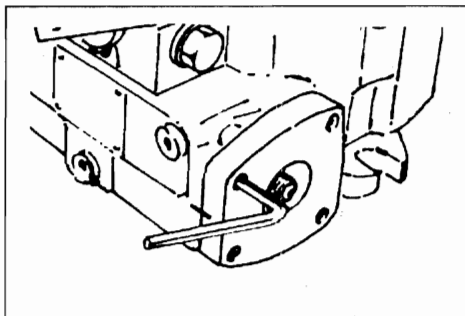

25 Deckel demontieren.

Remove cover.

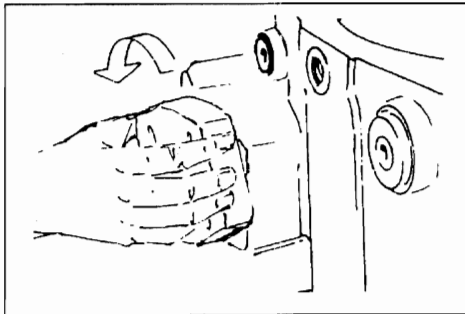

26 Deckel von Stellschraube "abschrauben".

Lift off by turning the setting screw.

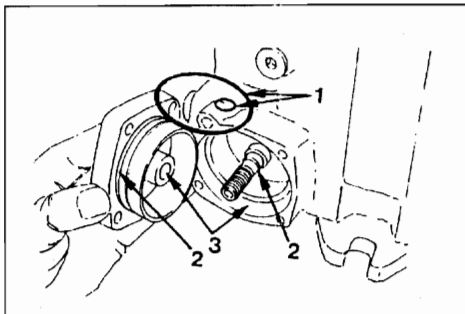

27 Kontrolle!  
O-Ring (1), Nut (2), Gehäuse (3).

Check!  
O-ring (1), groove (2), housing (3).

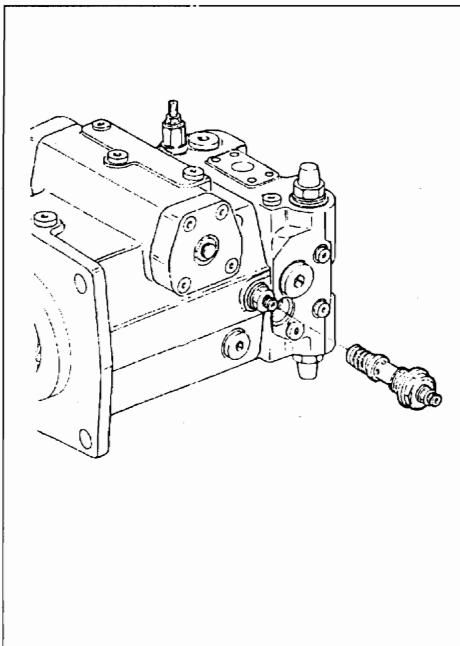
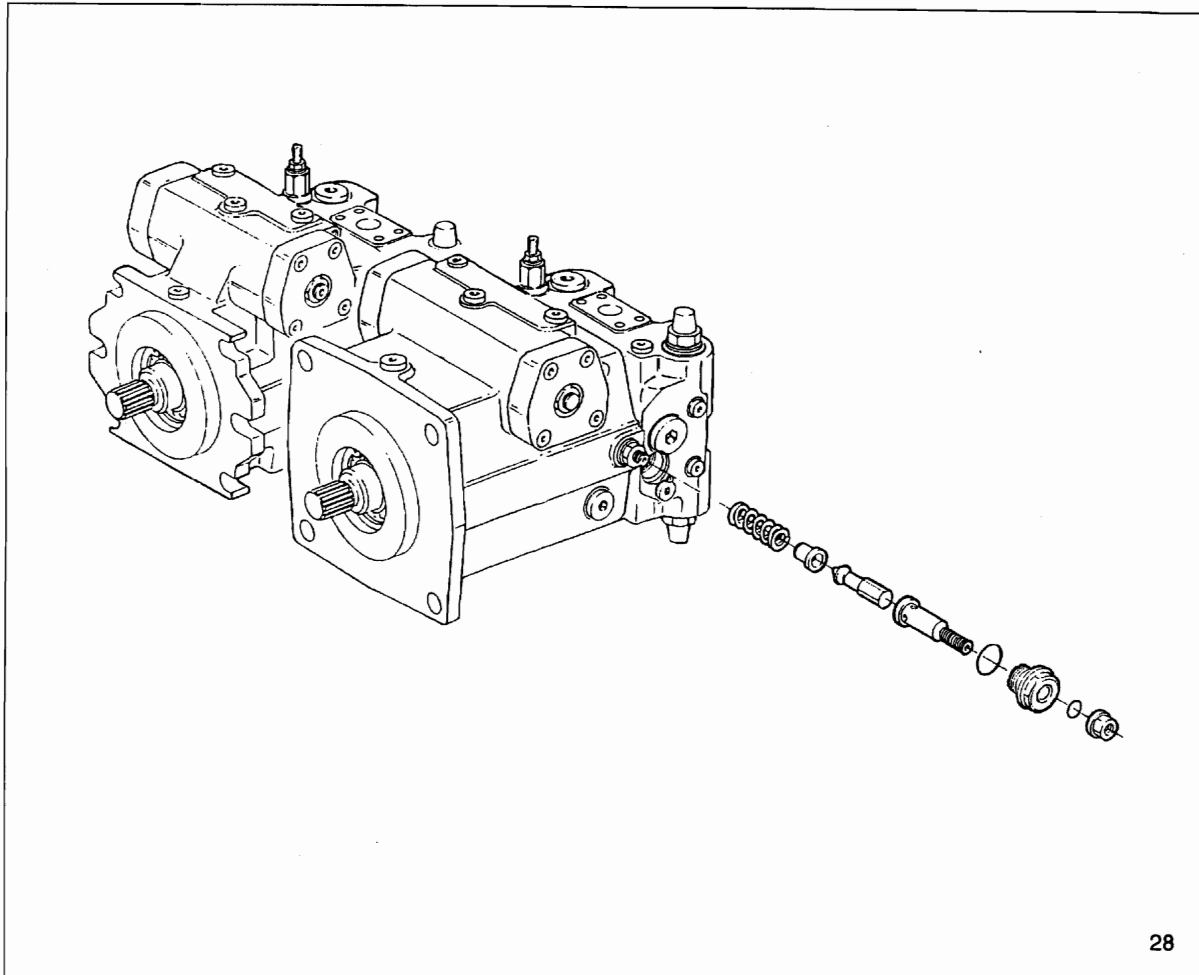

- 29 Ventil komplett ausbauen.  
Hinweis:  
Einstellschraube nicht verändern.  
Achtung!  
Nach Einbau Ventileinstellung überprüfen!
- Remove valve completely:  
Note:  
Do not change adjustment screw.  
Attention!  
Check valve setting after installation.

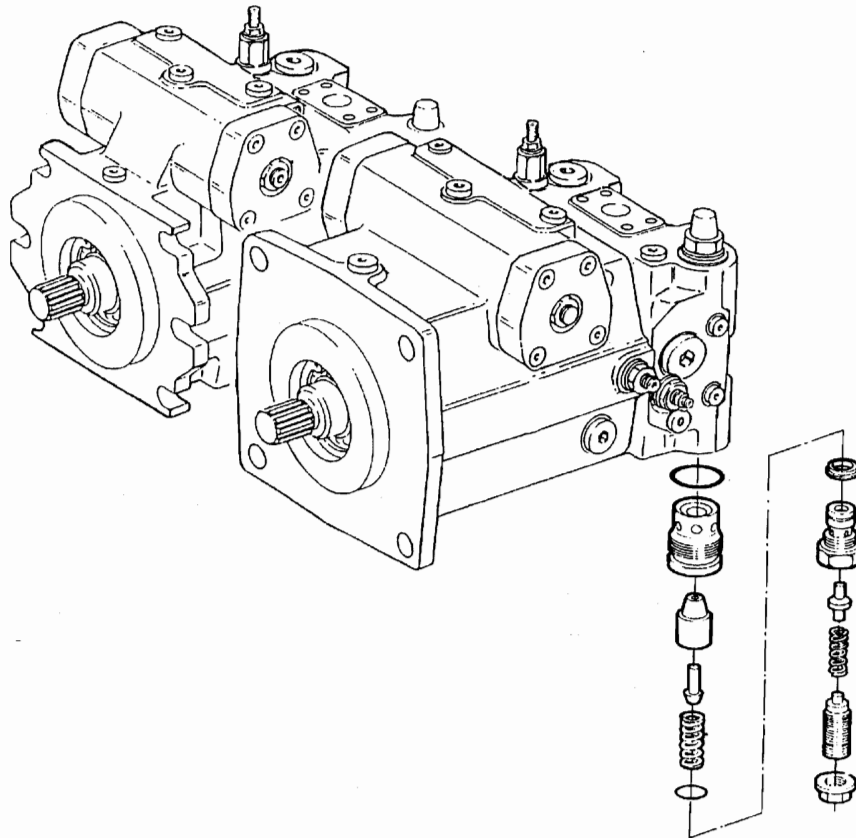

30

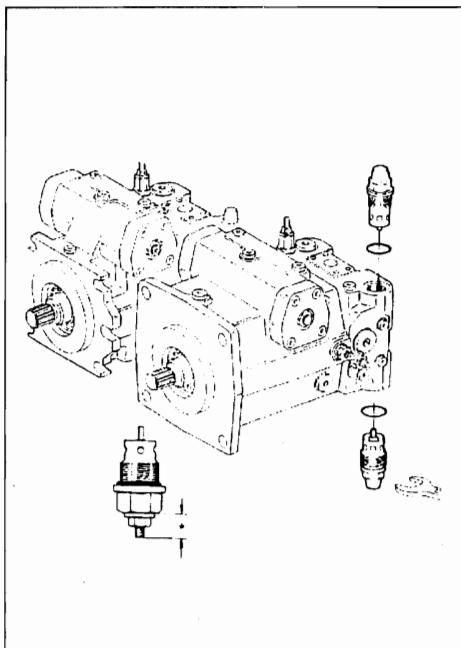

31

Ventil komplett ausbauen.  
Kontrolle: O-Ring, Gehäuse.  
Wechsel der Dichtmutter - Einstellmaß (\*) festhalten.  
Achtung!  
Nach Einbau "Ventileinstellung" überprüfen.

Remove valve completely.  
Control: O-ring, housing.  
Replacement of the tightening nut, record measure (\*).  
Attention!  
After assembly check "valve setting".

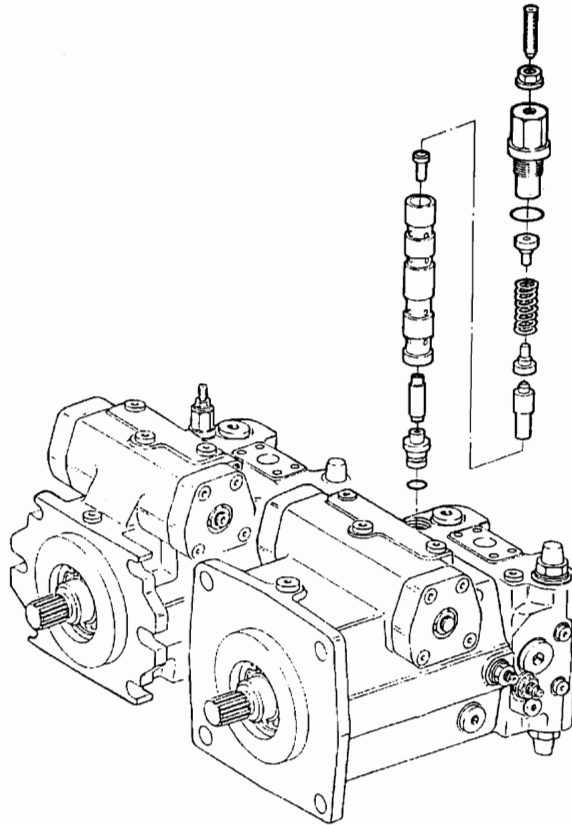

32

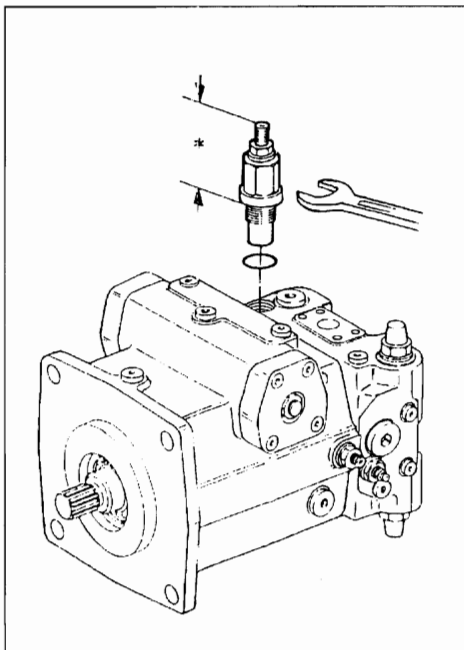

33

Einstellteil komplett ausschrauben.  
Kontrolle: O-Ring, Gehäuse.  
Wechsel der Dichtmutter - Einstellmaß (\*) festhalten.  
Achtung!  
Nach Einbau "Ventileinstellung" überprüfen.

Unscrew setting cartridge completely.  
Control: O-ring, housing.  
Replacement of the tightening nut, record measure (\*).  
Attention!  
After assembly check "valve setting".

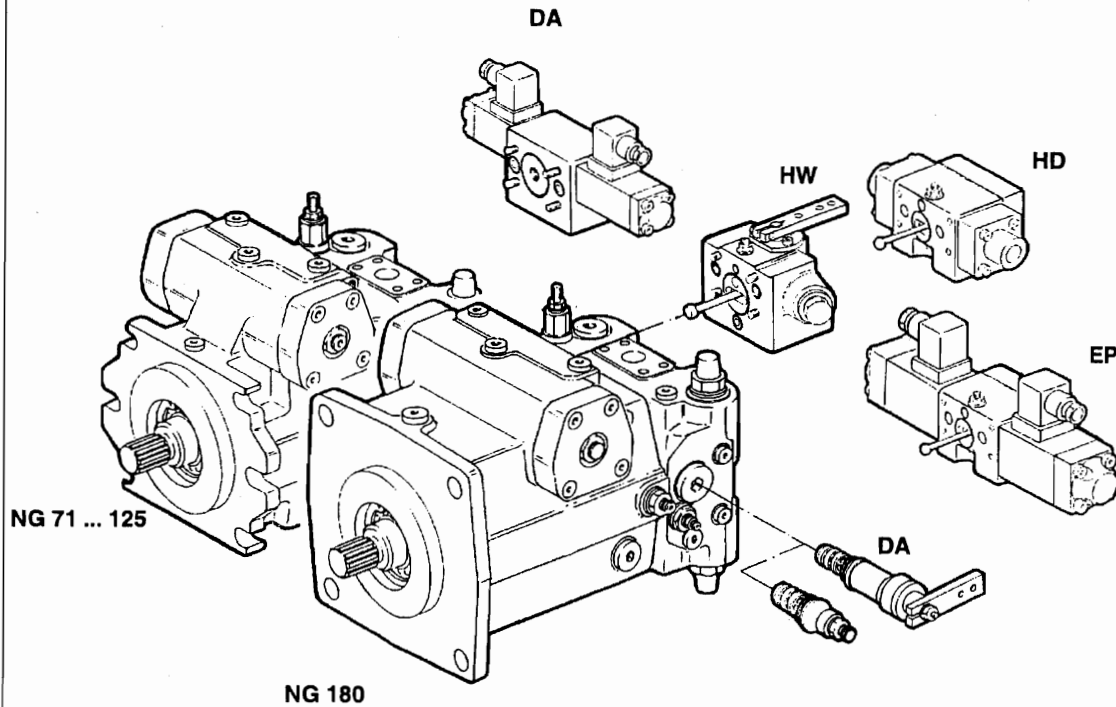

Ansteuergerät abbauen.

Remove control device.

Hinweis:

NG 71: Abdichtung der Ansteuergeräte wie NG 40 - 56 mit Flachdichtung.

Achtung!

Korrekte hydraulische Nullageneinstellung überprüfen.

Note:

Size 71: Sealing of control device as size 40 - 56 with flat seal.

Attention!

Check correct hydraulic 0-position.

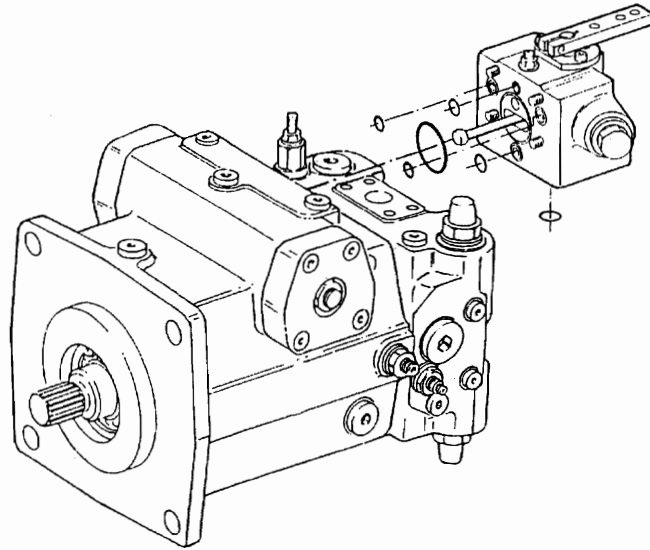

35

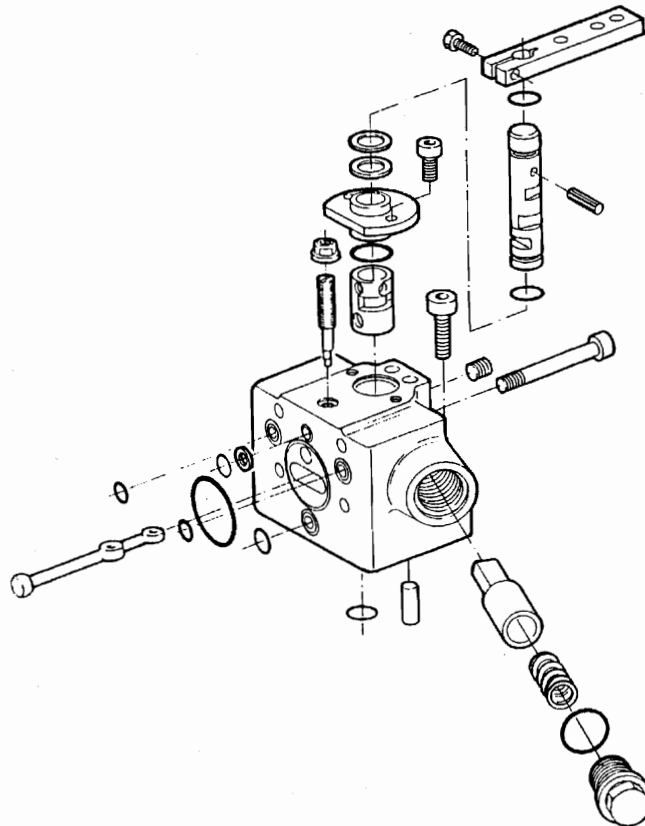

Kontrolle:  
O-Ringe und Dichtung.

Check:  
O-rings, gasket.

36

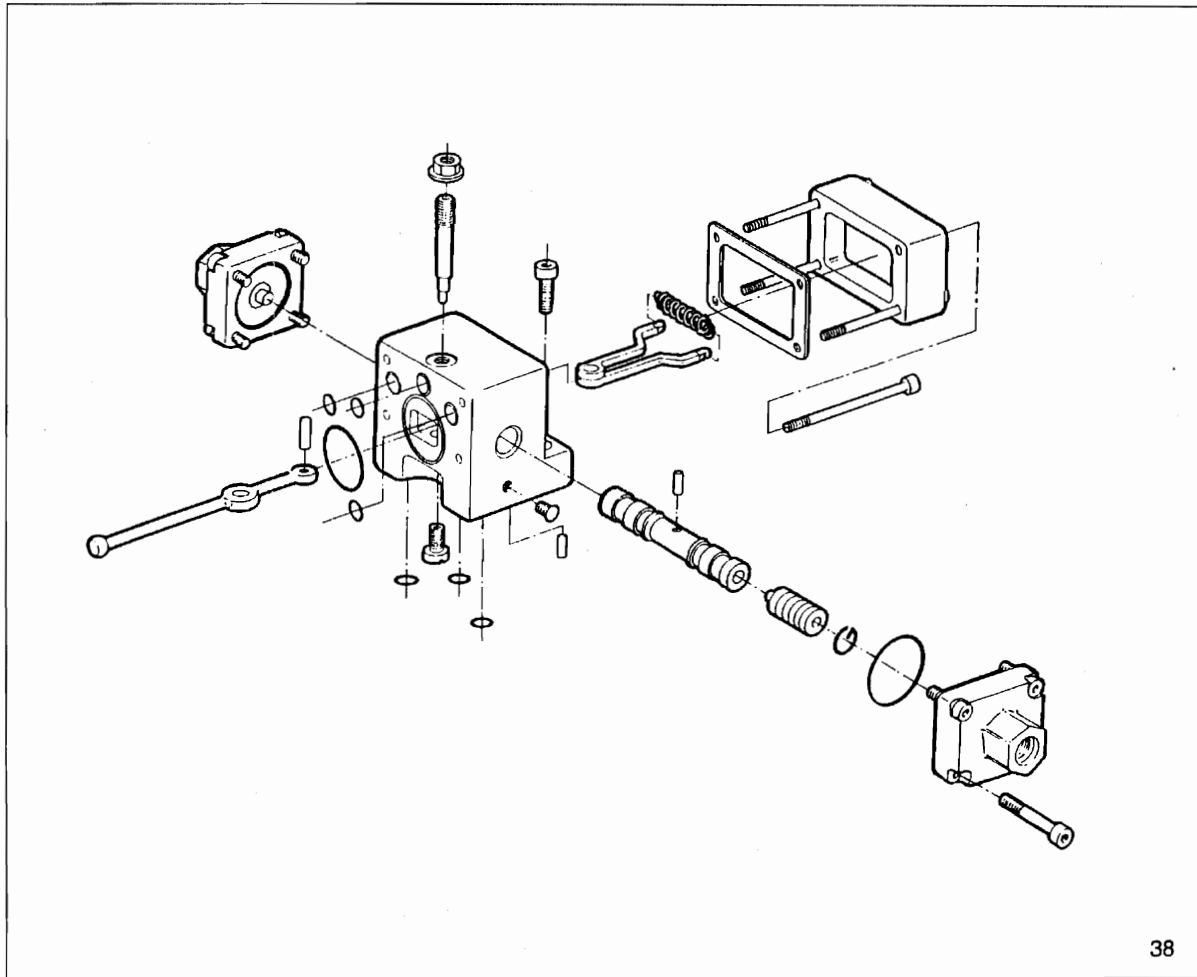
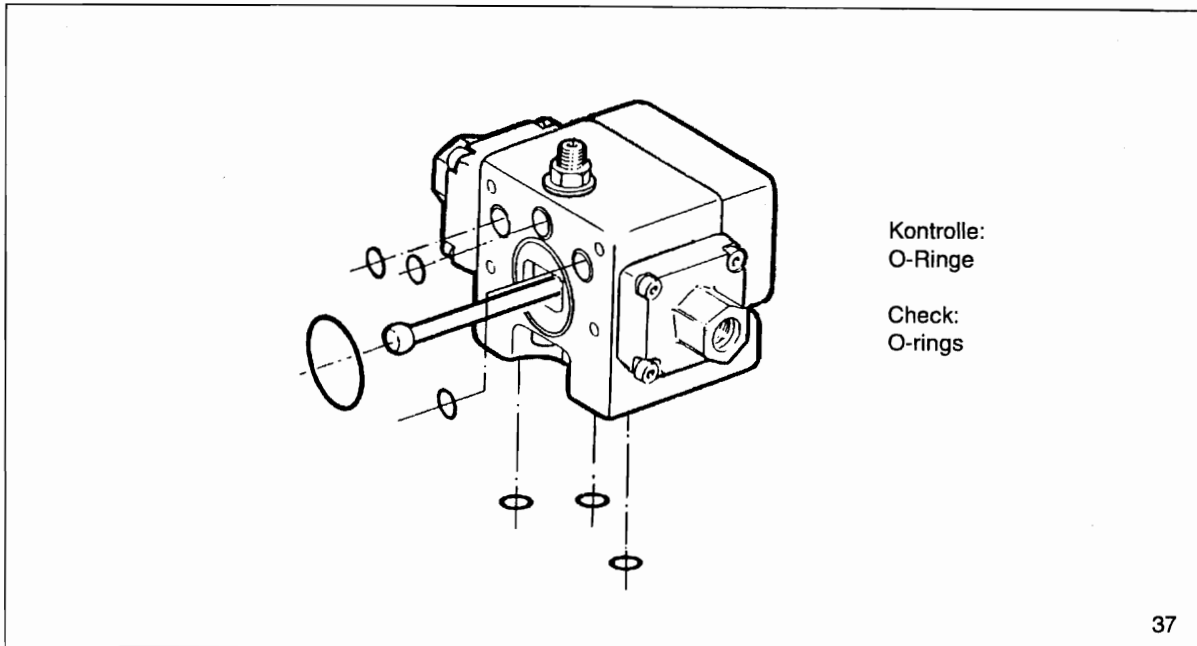



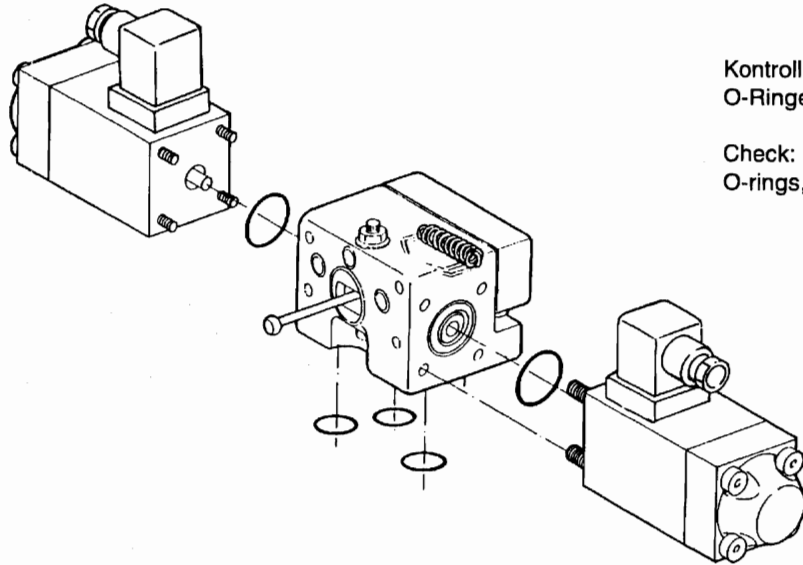

39

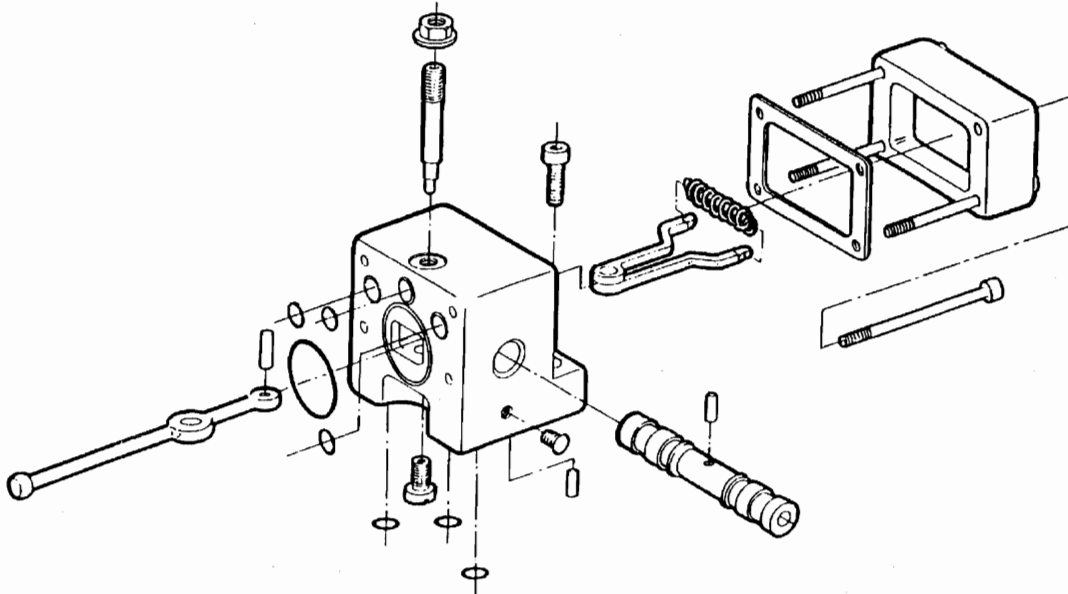

40

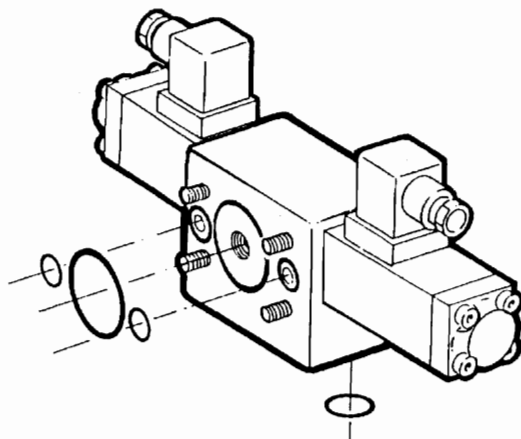

Kontrolle:  
O-Ringe

Check:  
O-rings

41

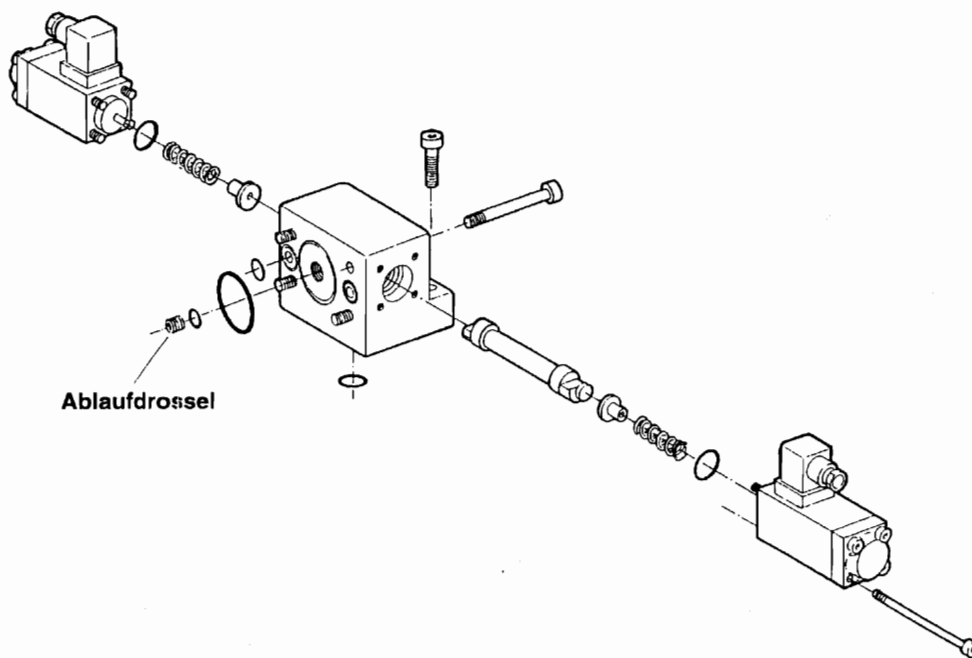

Ablaufdrossel

42

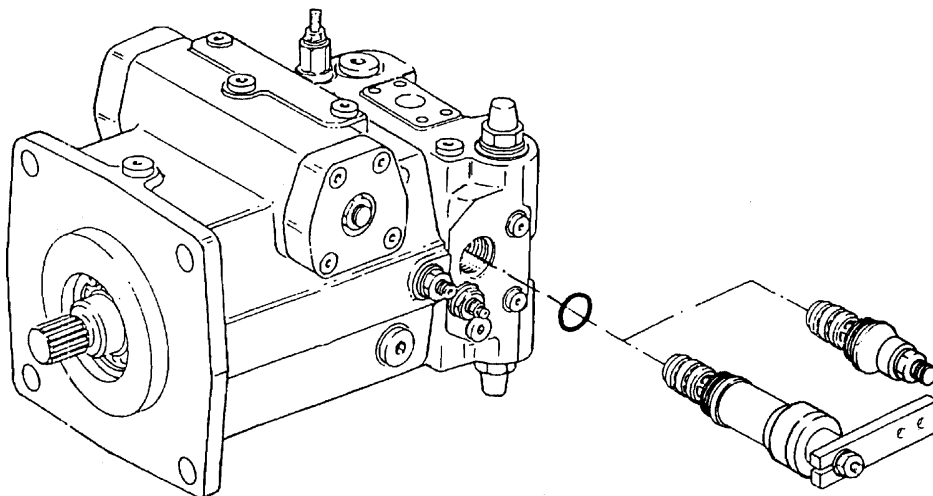

43

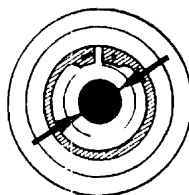

- 44 Blende überprüfen.  
Keine Beschädigung.

Inspect orifice.  
No damage.

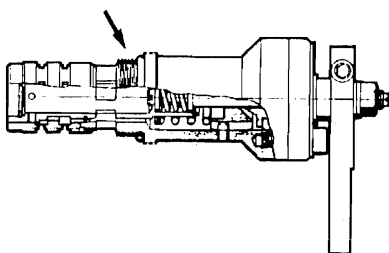

- 45 Gewinde abkleben.  
O-Ring einsetzen.

Cover threads.  
Insert O-ring.

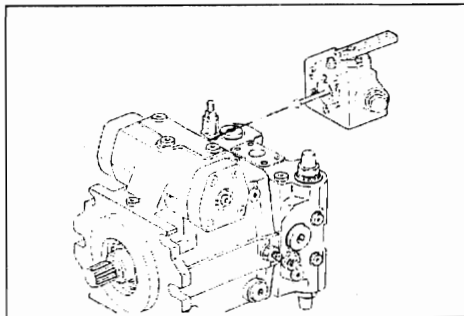
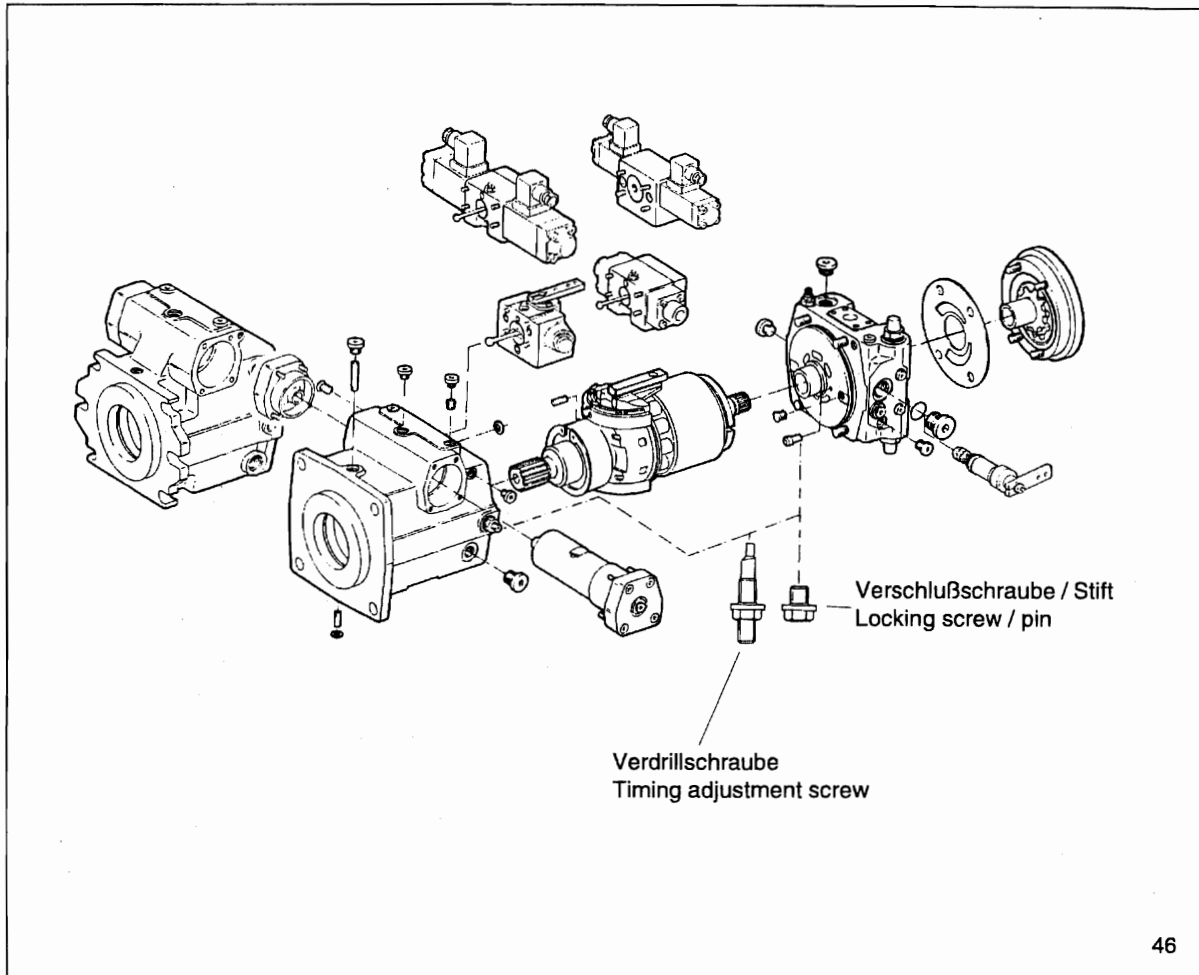

- 47 Ansteuergerät abbauen.  
Remove control device.

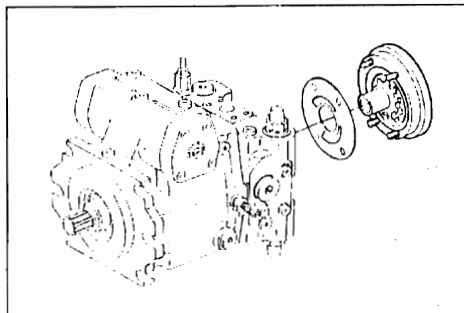

- 48 Hilfspumpe ausbauen.  
Hinweis:  
Einbaulage kennzeichnen.  
Remove auxiliary pump.  
Note:  
Mark assembly position previously.

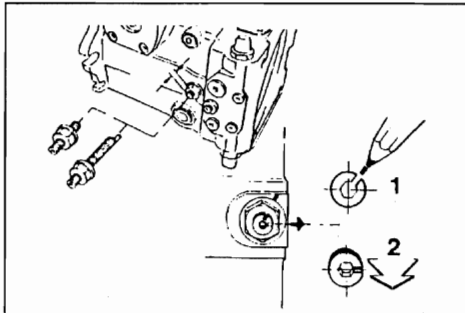

- 49 Lage der Verdrillschraube markieren (1).  
Einstellmaß festhalten.  
Verdrillschraube auf Demontageposition stellen (2).
- Mark the position of the indexing screw (1).  
Record setting measure.  
Set the indexing screw to disassembly position (2).

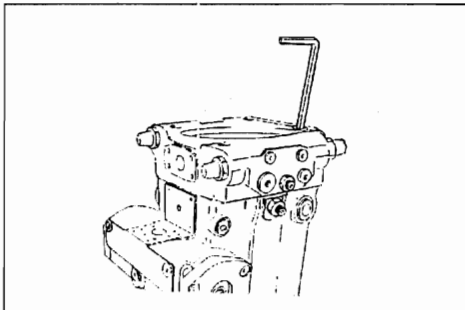

- 50 Lage der Hilfspumpe und Anschlußplatte markieren.  
Anschlußplattenbefestigung lösen.
- Mark position of the connection plate.  
Loosen connection plate fixation.

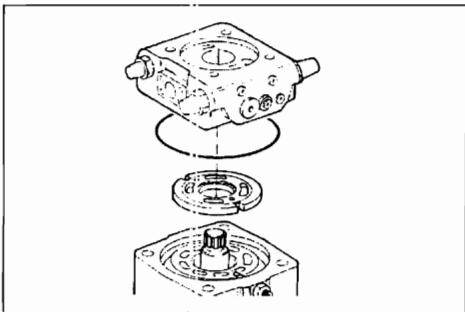

- 51 Anschlußplatte und Steuerplatte abheben.
- Lift off port plate and control plate.

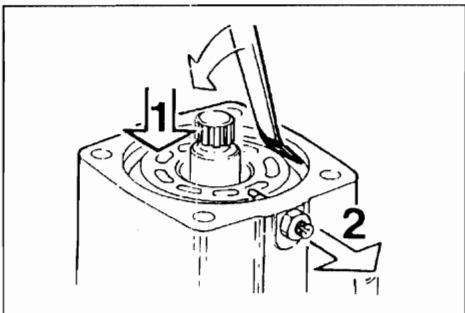

- 52 1. Zylinder nach unten drücken.  
2. Verdrillschraube herausdrehen.
1. Press the cylinder to the bottom.  
2. Remove fixing indexing screw.

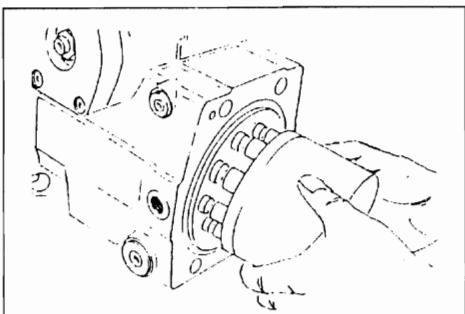

- 53 Zylinder komplett mit Kolben und  
Rückzugeinrichtung ausbauen.
- Push off hydraulic section of rotary group.

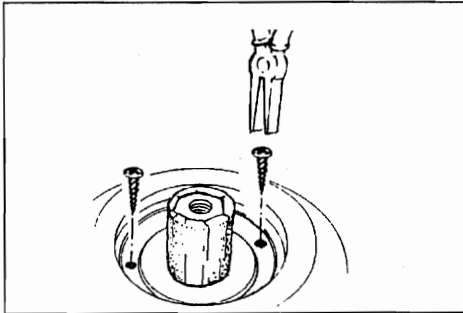

54 Seegerring / WDR ausbauen.

Remove retaining ring and radial seal ring.

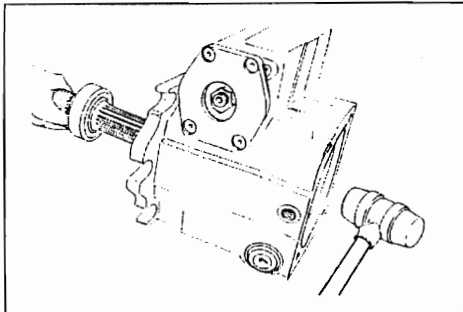

55 Triebwelle mit leichten Hammerschlägen austreiben.

Remove drive shaft with slide hammer strokes.

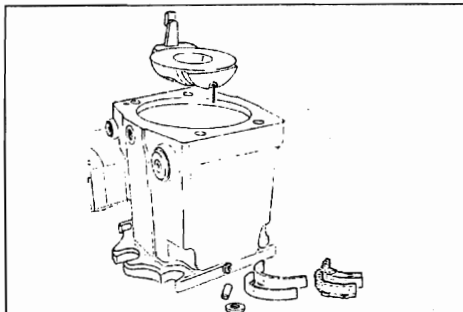

56 Schwenkplatte / Lager komplett ausbauen.

Remove swash plate / bearing cups.

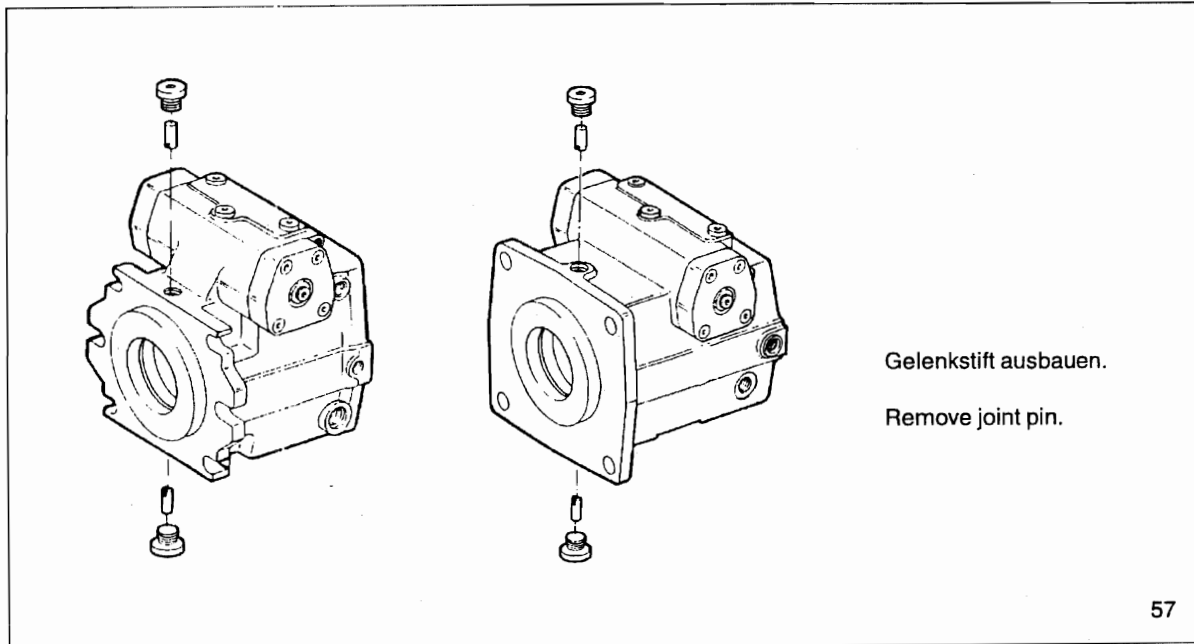

Gelenkstift ausbauen.

Remove joint pin.

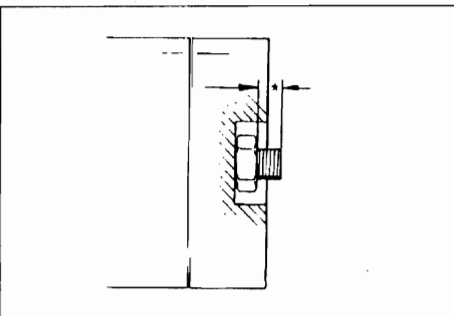
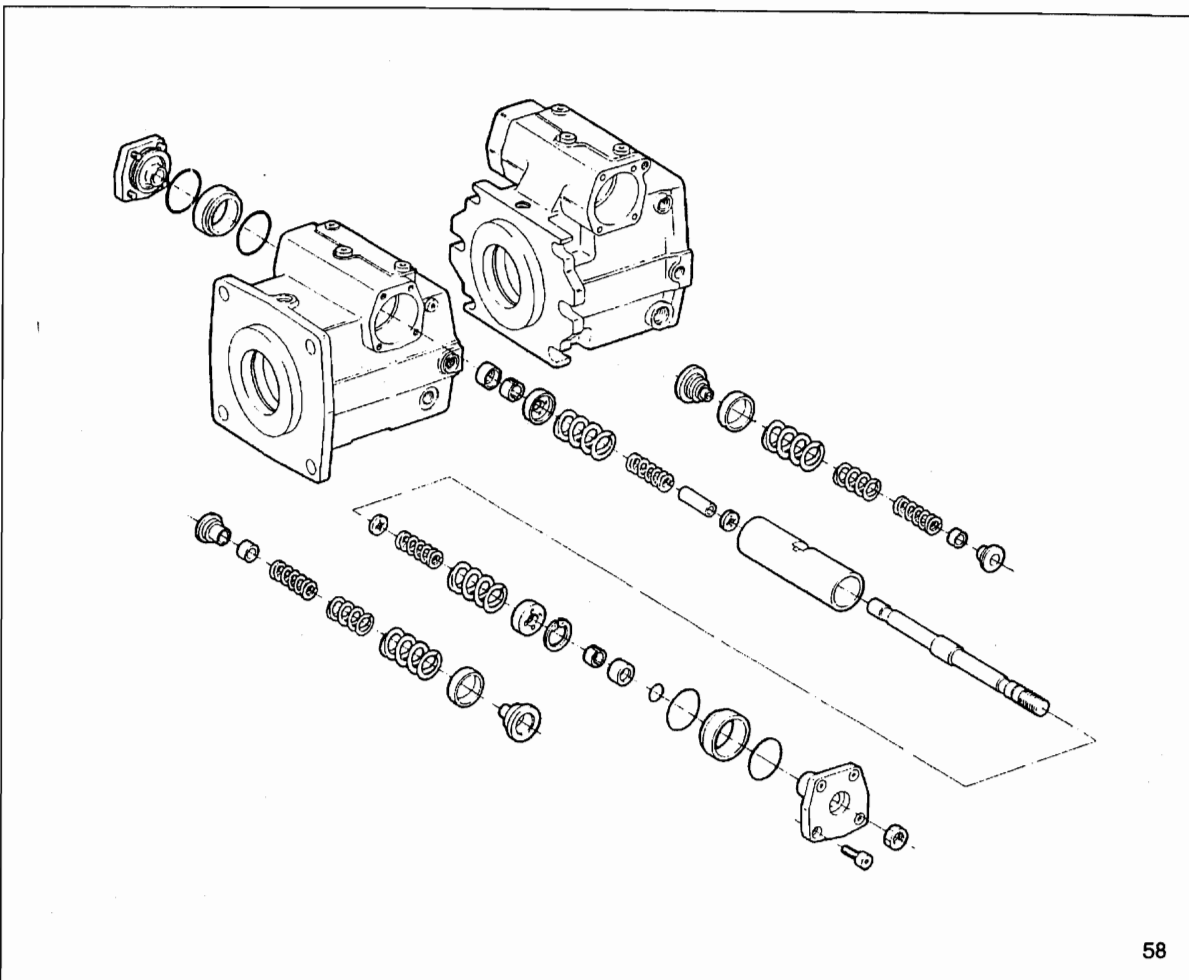

59 Lage vom Deckel markieren, Maß "Nullage" festhalten, Mutter lösen.

Mark position of the cover, note measure of "zero position".  
Loosen nut.

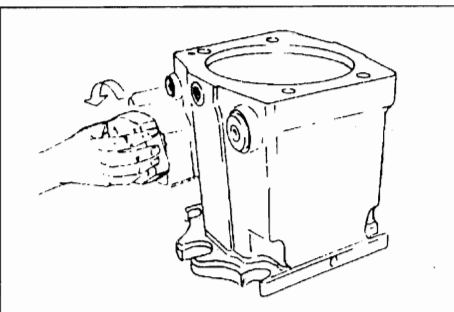

60 Deckel abdrehen.

Remove cover.

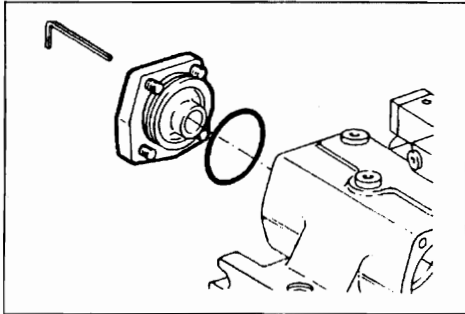

61 Lage des Deckels markieren.  
Befestigungsschrauben lösen, abbauen.

Mark position of the cover.  
Loosen locking screw, remove cover.

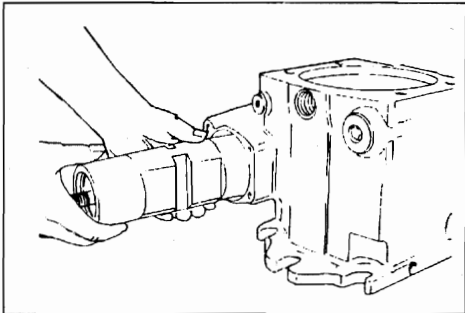

62 Stellzylinder ausbauen.  
Remove positioning ring.

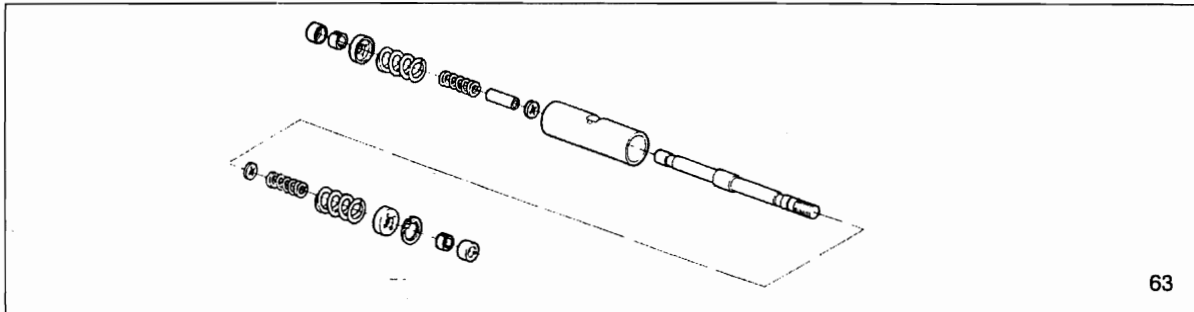

63

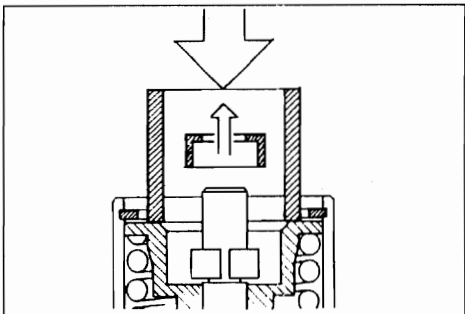

64 Vorrichtung aufsetzen und Feder vorspannen.  
Aufnahmering ausbauen.

Fit tool device and preload spring.  
Remove take-off ring.

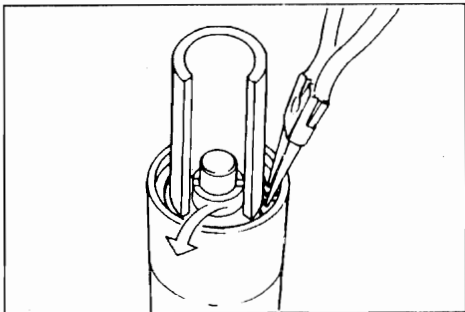

65 Ringe ausbauen.  
Sicherungsring ausbauen.  
Achtung: Teile stehen unter Federvorspannung.

Remove rings.  
Remove safety ring.  
Attention: Parts are under spring load.



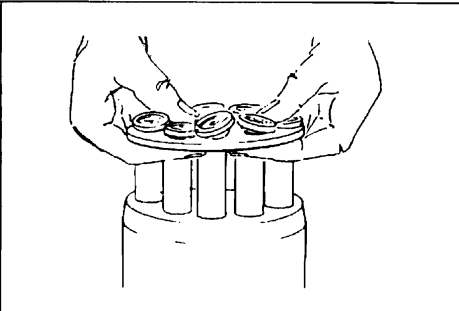

- 66 Kolben mit Rückzugeinrichtung ausbauen.  
Tragkugel mit Tellerfedersäule abheben.
- Remove piston with retaining plate.  
Remove retaining ball with spring cup assembly.

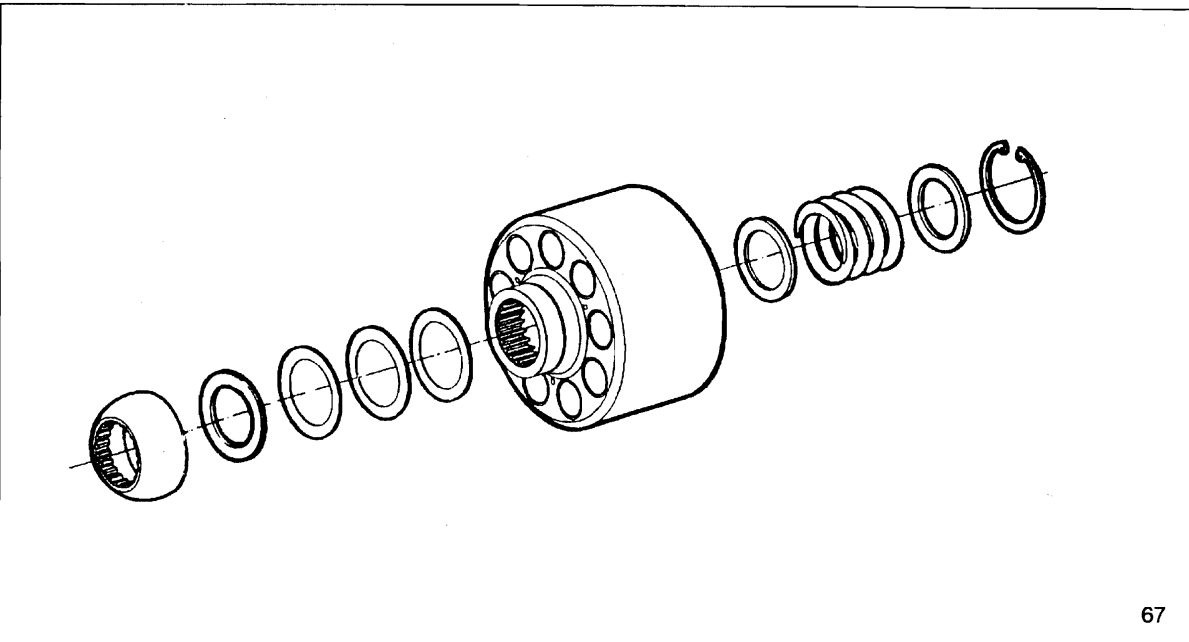

67

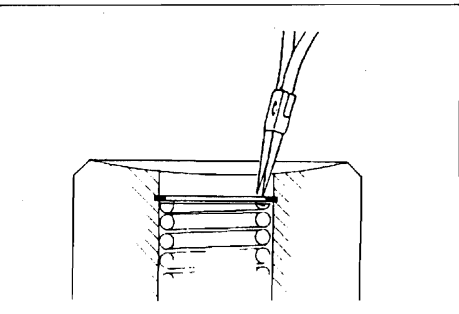

- 68 Sicherungsring ausbauen.
- Remove safety ring.

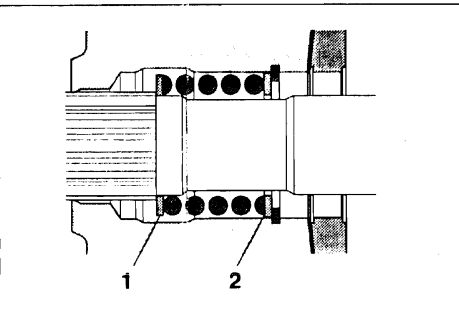

- 69 Scheibe 1, 2
- Disc 1, 2

Lager  
Bearing



Lagerschalen  
Bearing cup

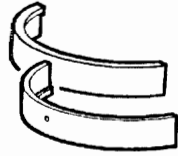

70 Kontrolle!  
Käfig-Paar (1),  
Lagerschalenpaar (2).

Check!  
Cage set (1),  
Bearing cup set (2).

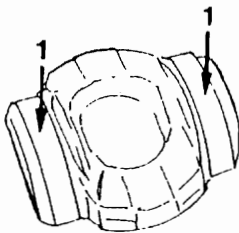

71 Kontrolle!  
Lagerbahnen (1)

Check!  
Bearing surfaces (1)

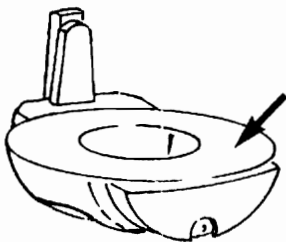

72 Kontrolle!  
Gleitfläche riefenfrei.

Check!  
Sliding surface free from scoring.

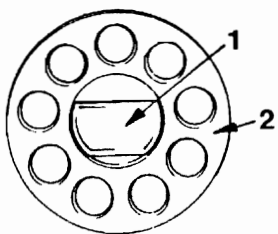

73 Kontrolle!  
Rückzugeinrichtung riefenfrei.

Check!  
Check that return device is free of scoring.

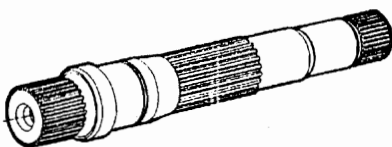

74 Kontrolle!  
1. Verzahnung "ausgeschlagen", Passungsrost.  
2. Laufflächen.  
3. Lauffläche - Wellendichtring.

Check!  
1. Splines for damage or fretting.  
2. Running surfaces.  
3. Groove cut by shaft seal.

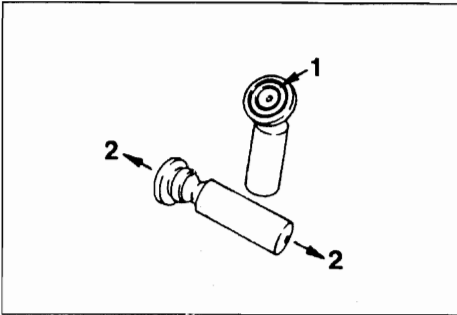

75 Kontrolle!  
Lauffläche (1) keine Kratzer, keine Metalleinlagerungen,  
kein Axialspiel (2), (Kolben nur satzweise tauschen).

Check!  
Check that there are no scratches or metal deposits on  
sliding surface (1), and there is no axial play (2),  
(otherwise: pistons must be replaced in sets).

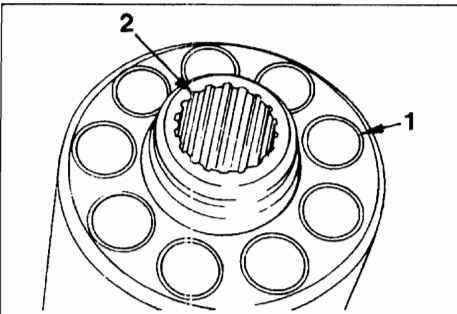

76 Kontrolle!  
Zylinderbohrungen (1), Verzahnungen (2).

Check!  
Cylinder bores (1), splines (2).

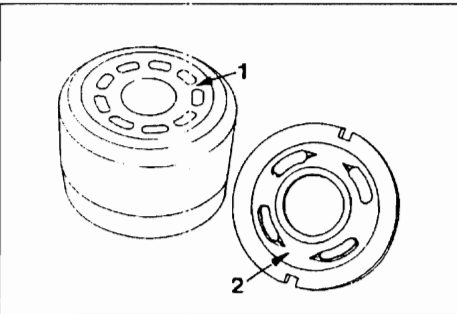

77 Kontrolle!  
Zylindergleitfläche (1) riefenfrei.  
Steuerplatte (2) nicht riefig.

Check!  
Cylinder surface (1) free of scoring.  
Control plate (2) without scoring.

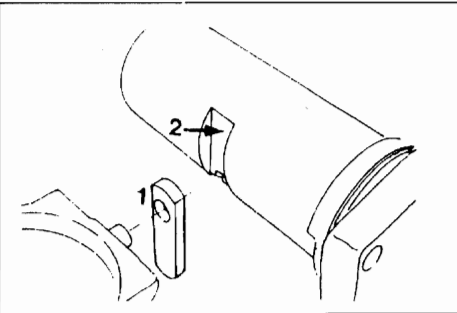

78 Kontrolle!  
Stellkolben - Schwenkwiegenverbindung  
Gleitstein (1), Nut im Stellkolben (2), Stellkolben.

Check!  
Positioning piston - cradle linkage  
Gliding stone (1), groove at the positioning piston (2).  
Positioning piston.

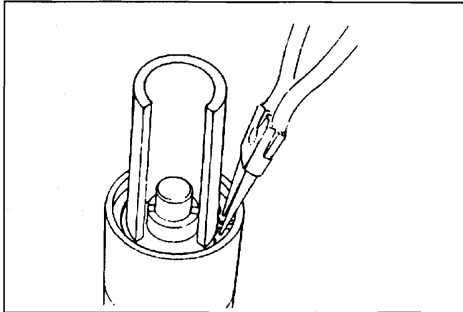

- 79 Stellkolben montieren.  
Hinweis:  
Auf korrekten Sitz der geteilten Ringe "achten".
- Assemble positioning piston.  
Instruction:  
Observe correct fit of the divided rings.

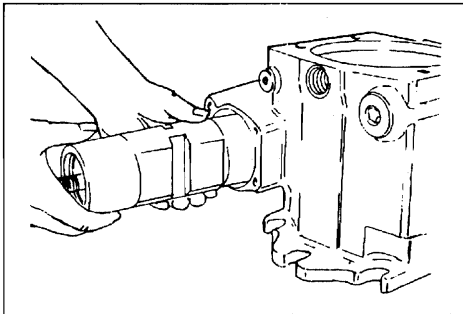

- 80 Stellkolben ins Gehäuse einsetzen.  
Hinweis:  
Stellkolben vor Einbau einölen.
- Insert positioning piston into the housing.  
Instruction:  
Oil positioning piston before assembly.

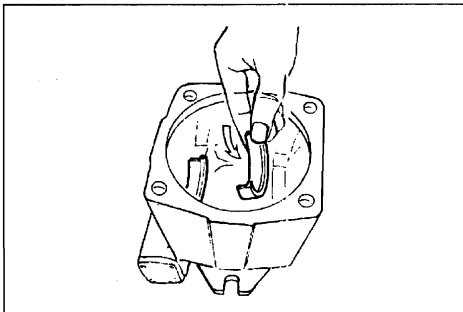

- 81 Lagerschalenpaar einsetzen.
- Insert bearing cup set.

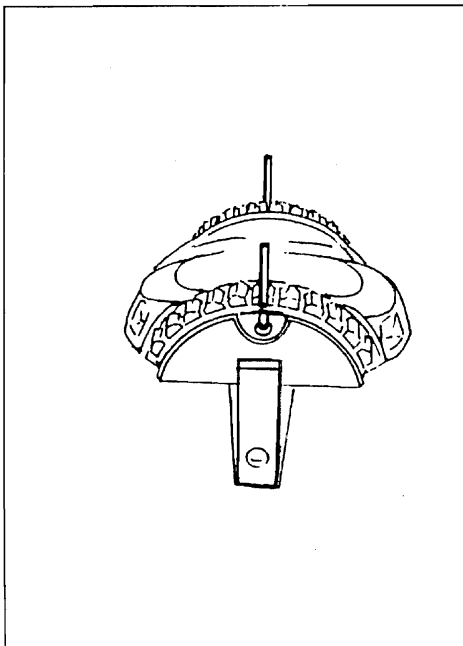

Lager, Draht, Gleitstein und Gelenkstift  
montieren.  
Montagehilfe: z.B. - Klammer / Gummiringe / Fett

Assemble bearing, wire, gliding stone  
and articulating pin.  
Assistance: Devices e.g. - Clamp / rubber rings / grease

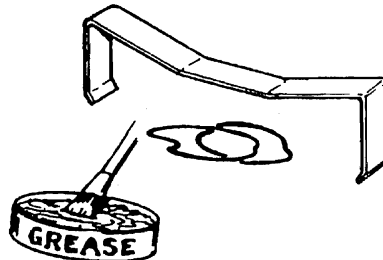

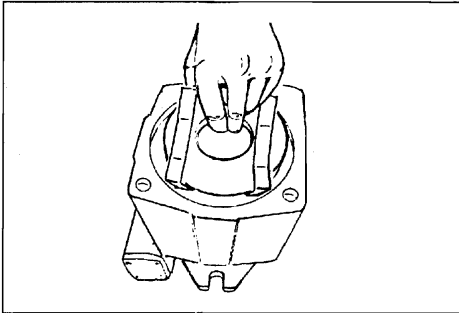

- 83 Schwenkwiège komplett ins Gehäuse einsetzen.  
Auf korrekten Sitz der Schwenklager im Gehäuse "achten".

⚠ Montagehilfe ausbauen.

Insert completely swivel cradle into the housing.  
Pay attention for correct seat of the swivel cradle in the housing.

⚠ Remove auxiliary device.

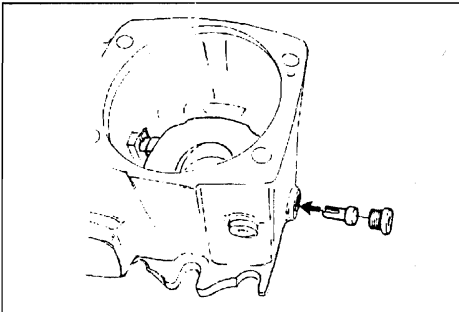

- 84 Gelenkstifte montieren.

Assemble articulating pins.

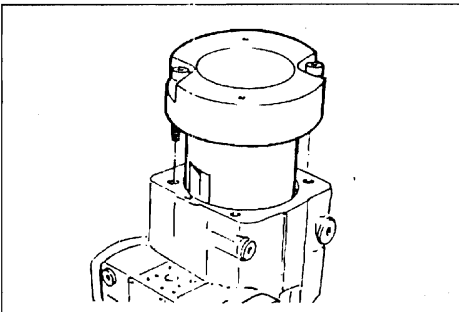

- 85 Vorrichtung zum Fixieren der Schwenkwiège montieren.

Assemble device for fixation of the swivel cradle.

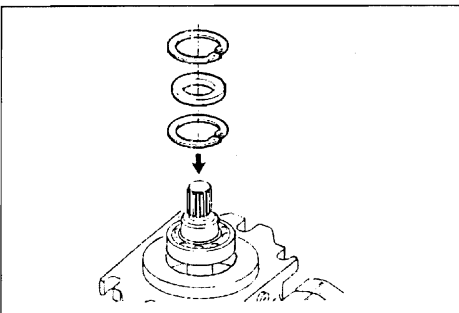

- 86 Neue Montageposition!  
Triebwelle mit Lager und Wellendichtring einbauen.

Assemble drive shaft with bearings and radial seal rings.

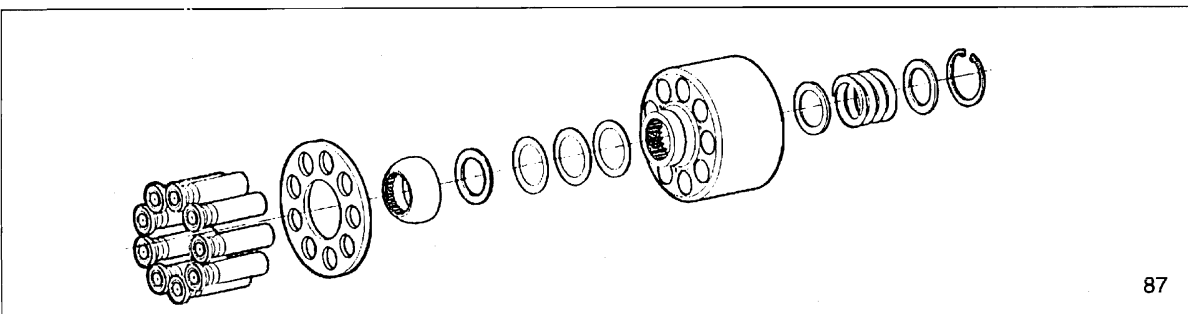

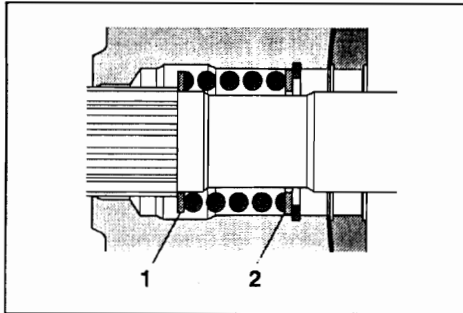

88 Scheibe 1, 2

Disc 1, 2

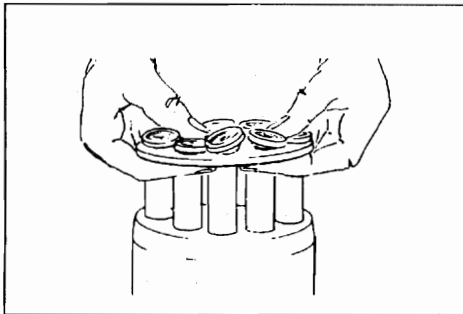

89 Kolben mit Rückzugeinrichtung montieren.

Hinweis:  
Kolben, Gleitschuhe einölen.

Assemble piston with retaining plate.

Note:  
Oil piston and piston pad.

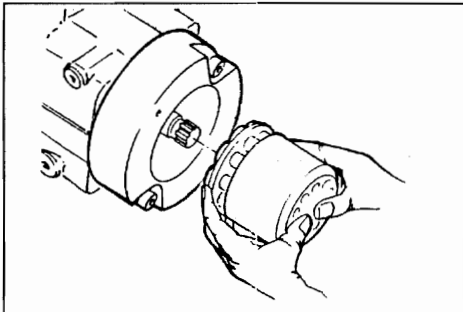

90 Zylinder komplett einbauen.

Assemble cylinder completely.

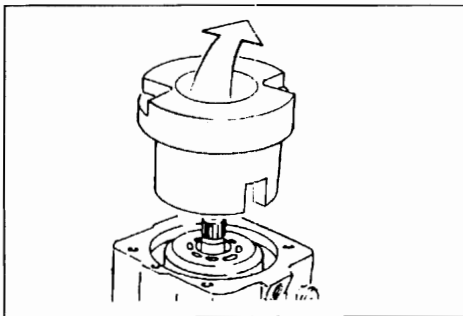

91 Vorrichtung ausbauen.

Remove assembly device.

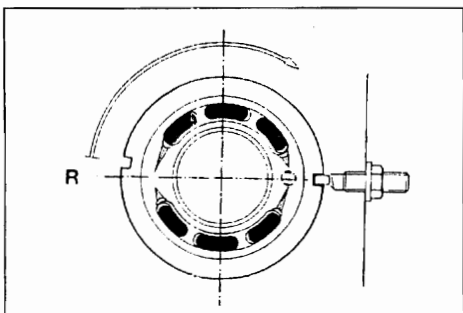

92 Steuerplatte Rechtslauf - in Drehrichtung verdreht.

Achtung!  
Geräuschkerben sind drehrichtungsbezogen eingeschliffen.

Control plate clockwise rotation - indexed in the direction  
of rotation.

Note!  
Noise grooves are machined - in based on direction  
of rotation.

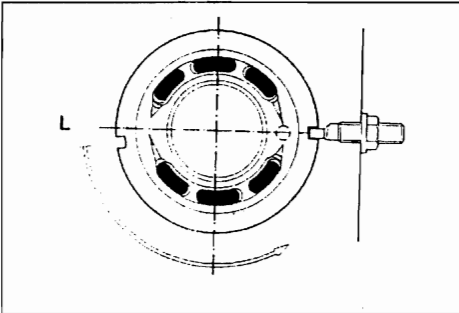

93 Steuerplatte Linkslauf - in Drehrichtung verdreht.  
Achtung!  
Geräuschkerben sind drehrichtungsbezogen eingeschliffen.

Control plate counter clockwise rotation - indexed in the direction of rotation.

Note!  
Noise grooves are machined - in based on direction of rotation.

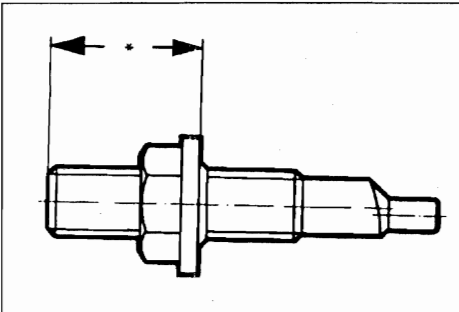

94 Grundeinstellung - Verdrillschraube  
A4VG...71 \* =  $28 \pm 0,75$  mm    A4VG...90 \* =  $29 \pm 0,75$  mm  
A4VG...125 \* =  $20 \pm 0,75$  mm    A4VG...180 \* =  $22 \pm 0,75$  mm.

Basic setting - indexing screw

A4VG...71 \* =  $28 \pm 0,75$  mm    A4VG...90 \* =  $29 \pm 0,75$  mm  
A4VG...125 \* =  $20 \pm 0,75$  mm    A4VG...180 \* =  $22 \pm 0,75$  mm.

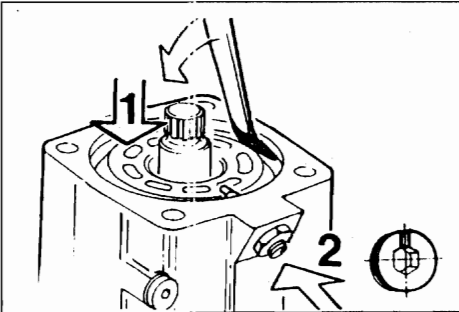

95 Steuerplatte einsetzen - Rechtslauf.  
Insert the control plate - clockwise rotation.

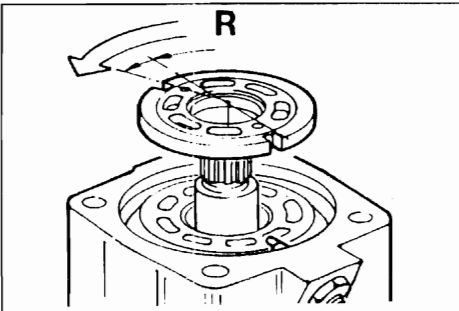

96 Zylinder nach unten drücken (1).  
Verdrillschraube einbauen (2).  
Kerbe in Montageposition.  
Press the cylinder to the bottom (1).  
Screw in the indexing screw (2).  
Groove in mounting position.

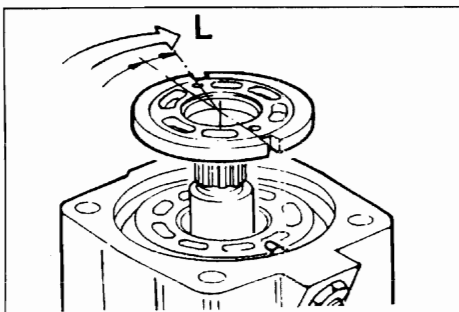

97 Steuerplatte einsetzen - Linkslauf.  
Insert the control plate - Counter- clockwise rotation.

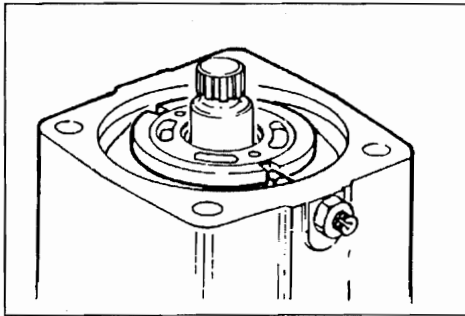

98

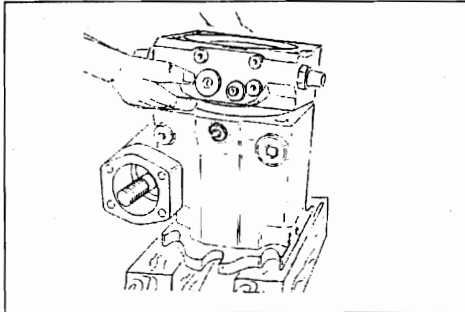

99

Anschlußplatte aufbauen.  
Achtung! Federvorspannung!  
Mit zwei Befestigungsschrauben überkreuz Anschlußplatte  
in Gehäuseführung einsetzen - Fertigmontage!

Assemble connection plate.  
Attention! Spring preloaded!  
Insert control plate into housing, guidance with two locking  
screws crossing over -Finish assembly!

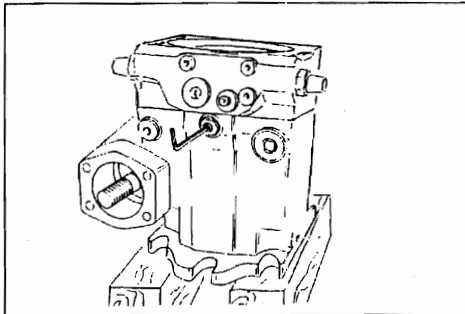

100

Verdrillschraube - Nach Markierung ausrichten.

Locking screw - Observe adjusting measure.

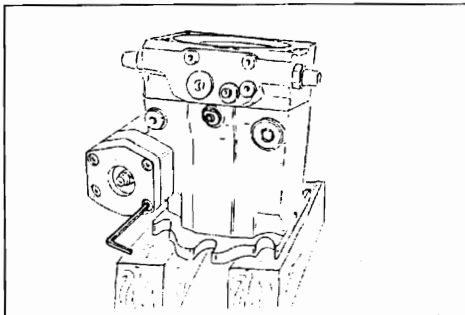

101

1. Deckel montieren.  
2. Nulllage nach Maß einstellen.

1. Assemble cover  
2. Adjust zero position according to measure.

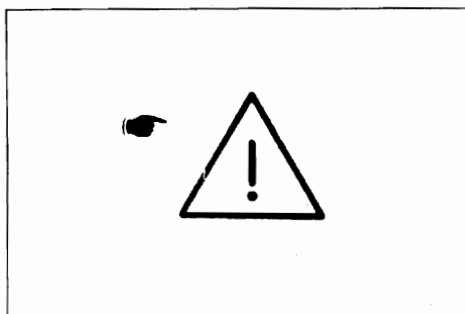

102

Achtung!  
Korrekte mechanische Nulllageneinstellung muß nach  
Einbau im Gerät bzw. Prüfstand erfolgen.

Attention!  
Adjustments of the correct zero position to be carried out  
after installation into the machine or on the bench test.



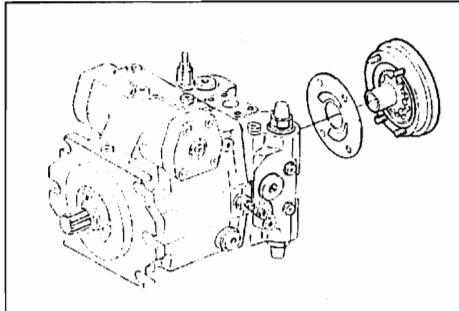

103 Hilfspumpe montieren.  
Hinweis: Drehrichtung beachten.

Assemble auxiliary pump.  
Note: Take care of direction of rotation.

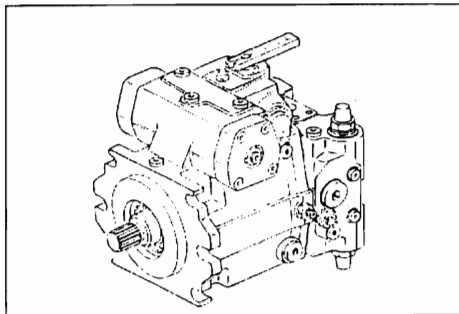

104 Ansteuergerät montieren.

Assemble control device.

### Tightening torques for shaft bolts (Metric ISO Standard Thread)

	Thread size	Strength Classes		
		8.8	10.9	12.9
The values for tightening torques shown in the table are valid only for shaft bolts with metric ISO- standard threads and head support surface dimensions in accordance with DIN 912, DIN 931 and DIN 933. These values are also valid only for light or uncoiled, untreated surface as well as for use only with torque-indicating wrenches and force limiting tools.				
		Tightening Torque (lb.ft)		
	M 3	0,8	1,2	1,4
	M 4	2,1	3,0	3,6
	M 5	4,4	6,3	7,4
	M 6	7,4	10,3	12,5
	M 8	18,4	25,8	30,2
	M10	36,1	50,9	61,2
	M12	63,4	88,4	106,9
	M14	99,5	140,0	169,5
	M16	154,8	217,4	261,6
	M18	213,7	298,5	357,4
	M 20	302,2	427,5	508,5
	M 22	405,4	574,9	685,4
	M 24	523,5	737,0	884,4
	M 27	773,9	1105,5	1326,6
	M 30	1068,7	1474,0	1768,8

### Tightening torques for locking screws VSTI (Metric ISO fine thread)

Thread size	Designation	Tightening torques (lb.ft)
M 8 x 1	VSTI 8 x 1 -ED/SA	= 4
M 10 x 1	VSTI 10 x 1 -ED	= 7
M 12 x 1,5	VSTI 12 x 1,5 -ED	= 15
M 14 x 1,5	VSTI 14 x 1,5 -ED	= 22
M 16 x 1,5	VSTI 16 x 1,5 -ED/SA	= 22
M 18 x 1,5	VSTI 18 x 1,5 -ED/SA	= 29
M 20 x 1,5	VSTI 20 x 1,5 -ED/SA	= 37
M 22 x 1,5	VSTI 22 x 1,5 -ED	= 44
M 26 x 1,5	VSTI 16 x 1,5 -ED/SA	= 51
M 27 x 2	VSTI 27 x 2 -ED	= 66
M 30 x 1,5	VSTI 30 x 1,5 -ED/SA	= 74
M 33 x 2	VSTI 33 x 2 -ED/SA	= 88
M 42 x 2	VSTI 42 x 2 -ED/SA	= 147
M 48 x 2	VSTI 48 x 2 -ED	= 220

### Tightening torques for seal-lock nuts (Metric ISO-Standard Thread)

	Thread size	Strength classes		
		8.8	10.9	12.9
The values for tightening torques shown in the table are valid only for seal-lock nuts of the strength class 8.8 and with metric ISO-standard thread.				
		Tightening torque (lb.ft)		
	M 6	7,4		
	M 8	16,2		
	M 10	29,5		
	M 12	50,9		
	M 14	81,1		
	M 16	125,3		

### Tightening torques for cross-slotted lens head screws DIN 7985 (Metric ISO- Standard Thread)

	Thread size	Strength classes		
		8.8	10.9	12.9
The values for tightening torques shown in the table are valid only for cross-slotted lens head screws DIN 7985 of the strength class 8.8 and with metric ISO-standard thread.				
		Tightening torques (lb.ft)		
	M 3	0,8		
	M 4	2,1		
	M 5	4,4		
	M 6	7,4		
	M 8	18,4		
	M10	36,1		

**General advice**

- Make yourself familiar with the equipment of the machine.
- Only operate the machine if you are completely familiar with the operating and control elements as well as the functioning of the machine.
- Use your safety equipment like helmet, safety shoes and hearing protection.
- Make yourself familiar with your working field.
- Only operate the machine for its intended purpose.

**Please observe the guidelines of the Professional Association and the machine manufacturer.**

**Before starting**

- Observe the operating instructions before starting.
- Check the machine for obvious faults.
- Do not operate the machine with defective instruments, warning lights or control elements.
- All safety devices must be in a secure position.
- Do not carry with you movable objects or secure them to the machine.
- Keep oily and inflammable material away from the machine.
- Before entering the driver's cabin, check if persons or obstacles are beside or beneath the machine.
- Be careful when entering the driver's cabin, use stairs and handles.
- Adjust your seat before starting.

**Start**

- When starting all operating levers must be in "neutral position".
- Only start the machine from the driver's seat
- Check the indicating instruments after start to assure that all functions are in order.
- Do not leave the machine unobserved when the motor is running.
- When starting with battery connection cables connect plus with plus and minus with minus. Always connect negative (-) cable last and disconnect negative cable first.

**Attention**

- Exhaust gas is dangerous. Assure sufficient fresh air when starting in closed rooms!

**Hydraulic equipment**

1. Hydraulic equipment is standing under high pressure.  
 High pressure fluids (fuel, hydraulic oil) which escape under high pressure can penetrate the skin and cause heavy injuries.  
Therefore immediately consult a doctor as otherwise heavy infections can be caused.
2. When searching leakages use appropriate auxiliary devices because of the danger of accidents.
3. Before working at the hydraulic equipment, lower pressure to zero and lower working arms of the machine.
4. When working at the hydraulic equipment, absolutely stop motor and secure machine against rolling away (parking brake, shim)!
5. When connecting hydraulic cylinders and motor pay attention to correct connection of hydraulic flexible hoses.
6. In case of exchanging the ports, the functions are vice versa (f. ex. lift-up/lower) - danger of accidents!
7. Check hydraulic flexible hoses regularly and replace them in case of damage or wear! The new hose pipes must comply with the technical requirements of the machine manufacturer!

Orderly disposal or recycling of oil, fuel and  
 filters!

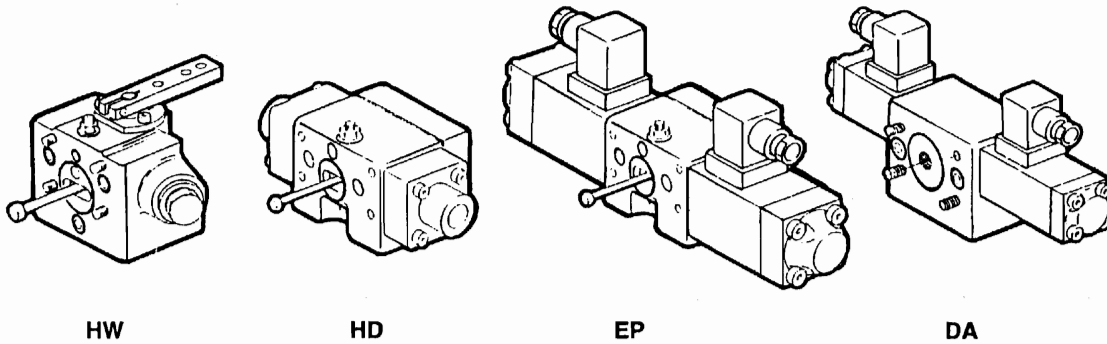

105

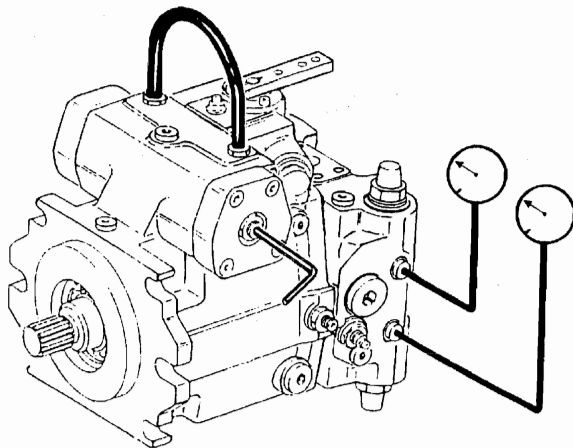

**Achtung!**  
Sicherheitsbestimmungen beachten!  
Mit Schlauch NW6 beide Stellkammern verbinden. Vermeidung von Restsignal aus hydraulischer Nulllage.  
Manometer an  $M_A$  und  $M_B$  anschließen.  
Nullage so einstellen, daß bei blockiertem Antrieb beide Manometer auf gleichem Druckwert stehen.  
Hinweis:  
Totband der Nullage - vermitteln.

**Attention!**  
Observe safety regulations!  
Connect both control chambers with hose NW6. Avoidance of rest signal from hydraulic zero position.  
Connect manometer to  $M_A$  and  $M_B$ . Adjust zero position so that at blocked drive both manometer indicate the same pressure valve.  
Note:  
Adjust death line of zero position.

106

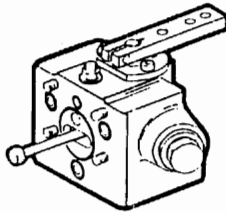

HW

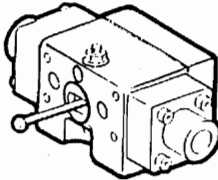

HD

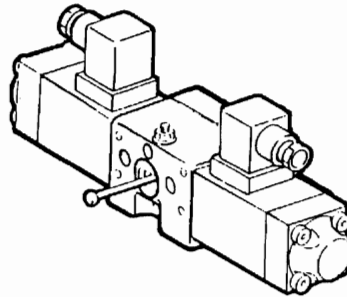

EP

Achtung!  
Sicherheitsbestimmungen beachten!

Attention!  
Observe safety regulations!

107

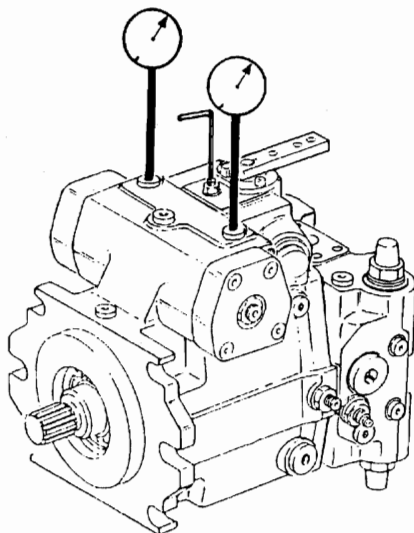

Manometer an X<sub>1</sub> und X<sub>2</sub> anschließen.  
Nullage so einstellen, daß bei blockiertem  
Antrieb beide Manometer auf gleichem  
Druckwert stehen.

Hinweis:  
Excenterjustierung  
- nicht über  $\pm 90^\circ$  verdrehen.

Connect manometer to X<sub>1</sub> and X<sub>2</sub>.  
Adjust zero position so that at blocked drive  
both manometer indicate the same pressure  
value.

Note:  
Eccentric adjusting  
- Do not turn over  $\pm 90^\circ$ .

108

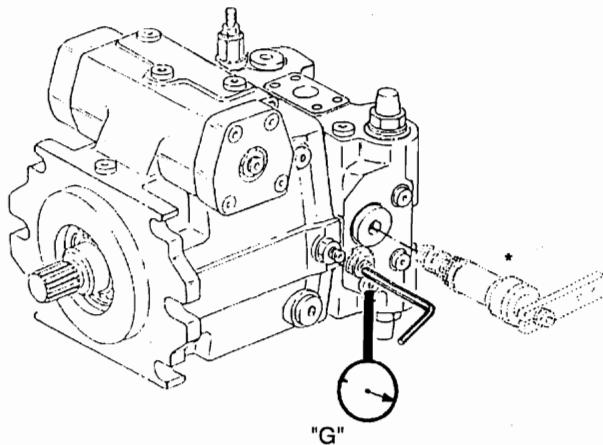

Achtung!  
Sicherheitsbestimmungen beachten!

Hinweis:  
Nachjustierung nur bei Betriebstemperatur.

Manometer an "G" anschließen.

Achtung!  
\* Speisedruckeinstellung!  
Nenndruck  $p_H$  - 18 bar  
Höchstdruck  $p_H$  - 40 bar  
Bei Max.-Drehzahl.

Hinweis:  
Einstelldaten nach Werksauftrag.

\* bei DA-Ausführung

Attention!  
Observe safety regulations!

Note:  
Readjusting only at operating temperature.

Connect manometer to "G".

Attention!  
\* Boost pressure setting!  
Nominal pressure  $p_H$  - 18 bar  
Peak pressure  $p_H$  - 40 bar  
at max. speed.

Note:  
Adjusting data according to order.

Druckabschneidung  
Pressure cut-off

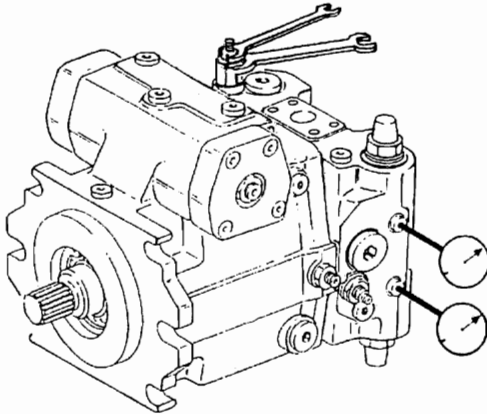

110

**Achtung!**  
Sicherheitsbestimmungen beachten!

#### HD-Ventil ohne Bypass

1. HD- Ventile sind immer 10% höher eingestellt als die Druckabschneidung.  
Bei Veränderung eines Einstellwertes immer beide kontrollieren.
2. Nachjustierung nur bei Betriebstemperatur

Manometer an  $M_A$  und  $M_B$  anschließen.  
Druckabschneidung: Maß X Einstellschrauben notieren!  
Einstellschraube auf Block drehen.

HD- Ventile: Mit geringer Pumpenmenge über Ventile fahren. Einstellwert kontrollieren.  
(Nur kurzzeitig "Temperatur".)

Drucklos "Einstellwert" verändern - Kontrolle

Druckabschneidung:  
Einstellschraube auf Maß (\*) zurückdrehen.  
Druckwert kontrollieren bzw. nachjustieren.  
**Achtung!** Differenz von 10% HD- Ventile und Druckabschneidung beachten!  
Hinweis: Einstelldaten nach Werksauftrag.

**Attention!**  
Observe safety regulations.

#### HP valve without bypass-function

1. HP valves are always adjusted 10% higher than the pressure cut-off.  
If one setting value is changed, always check both values.
2. Readjusting only at operating temperature.

Connect manometer  $M_A$  and  $M_B$ .  
Pressure cut-off: Note measure X setting screw! Turn setting screw on block.  
HP valves: Operate valves with small pump flow volume.  
Check setting value. ("temperature" only for a short time).  
Change "setting value" - check.

Pressure cut-off:  
Turn back setting screw to measure (\*).  
Check pressure value and readjust.  
**Attention!** Observe 10% pressure difference HP valves and pressure cut-off!

HD- Ventile  
HP- valves

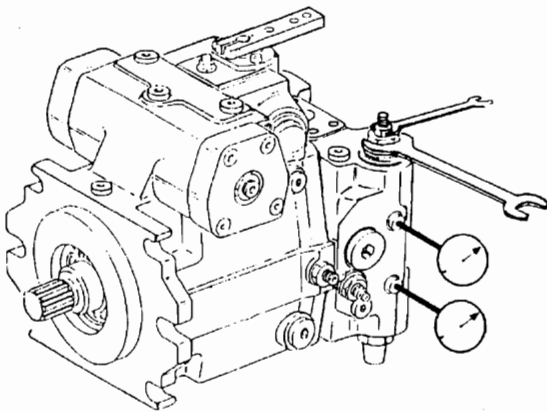

111

### A4VG 71 - 90

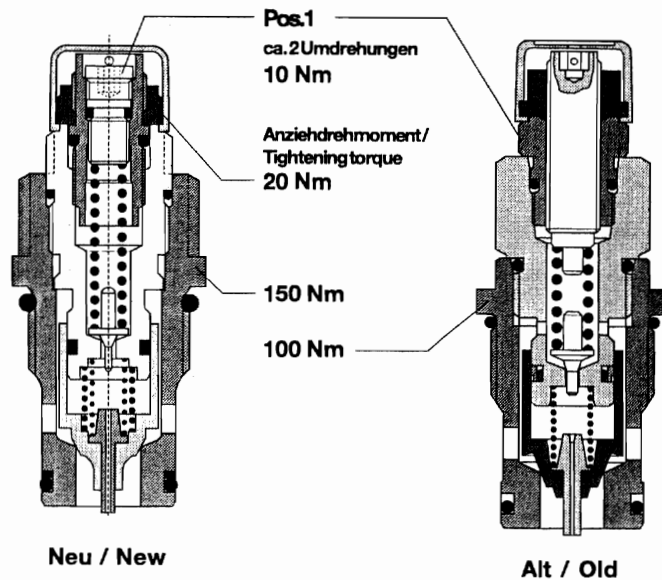
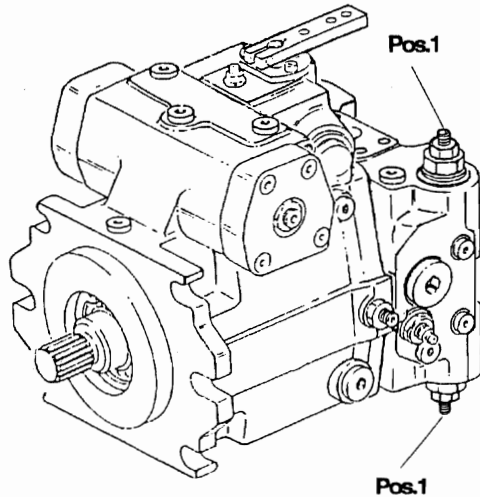

Fahrzeuge mit rein-hydrostatischem Fahrtrieb bzw. mit hydrostatischem Fahrtrieb und Schaltgetriebe ohne Leerlaufstellung (Freilauf).

Vehicle with hydrostatic transmission and gear shift without idling setting position (free wheeling).

#### Hydrostatischer Antrieb / Bypass-Schaltung

#### Hydrostatic transmission / Bypass-switching

In diesem Fall wird der Fahrtrieb auf freien Umlauf geschaltet. Zu diesem Zweck haben die in der Verstellpumpe integrierten Hochdruckbegrenzungsventile eine sogenannte Bypass-Funktion. D.h. durch Drehen der entsprechenden Schraube (Pos.1) wird der Ventil-Einsatz so entspannt, daß ein freier Öl-Umlauf möglich ist.

In this case the travel transmission is switched on to free wheeling. For this purpose the variable displacement pump has incorporated high pressure relief valves with bypass function. The screw (item 1) is unscrewed to such an extent, that the valve cartridge is released and free oil circulation is possible.

### A4VG 125 - 250

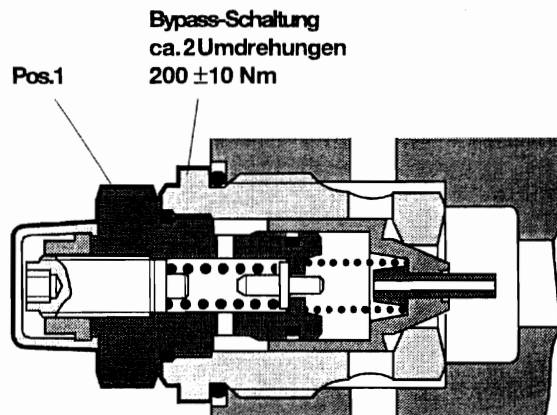
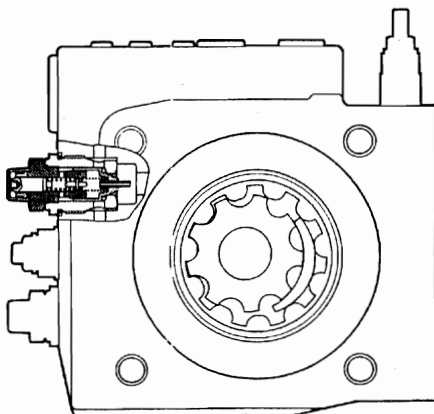

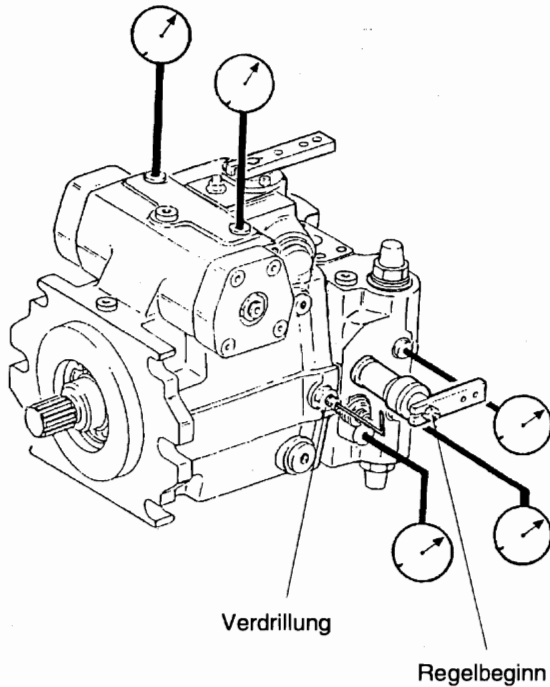

113

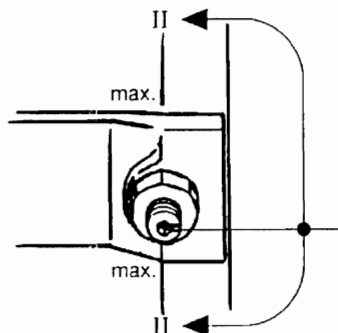

114

**Achtung!**  
Sicherheitsbestimmungen beachten!

Überprüfung der Einstelldaten  
Betriebstemperatur soll während des Überprüfungs Vorgangs weitgehend konstant gehalten werden.  
Antriebsmotor starten, Leerlaufdrehzahl

#### Blockzustand

Fahrtrichtungsschalter "0"  
Motordrehzahl langsam steigern bis zur max.  
Motordrehzahl, dabei Meßgeräte beobachten.  
Speisedruck:  
Leerlaufdrehzahl  
Psp = ca. 15-20 bar  
max. Motordrehzahl  
Psp = ..... bar\*

#### Blockzustand

Fahrtrichtungsschalter - vorwärts  
(Straßengang und Festgebremst)

Einstelldaten Pumpe A4V/DA überprüfen

#### Regelbeginn

HD 40 - 50 bar  
Motordrehzahl ..... min.<sup>1</sup>\* Psp ..... bar\*  
HD ..... bar  
Nachjustierung - Regelbeginnschraube

#### Regelende

HD ..... bar\*  
Motordrehzahl ..... min.<sup>1</sup>\* Psp ..... bar\*  
Nachjustierung - Verdrillschraube

Hinweis:  
Excenterjustierung - Drehrichtung beachten

Hinweis: \* Einstelldaten nach Werksauftrag!



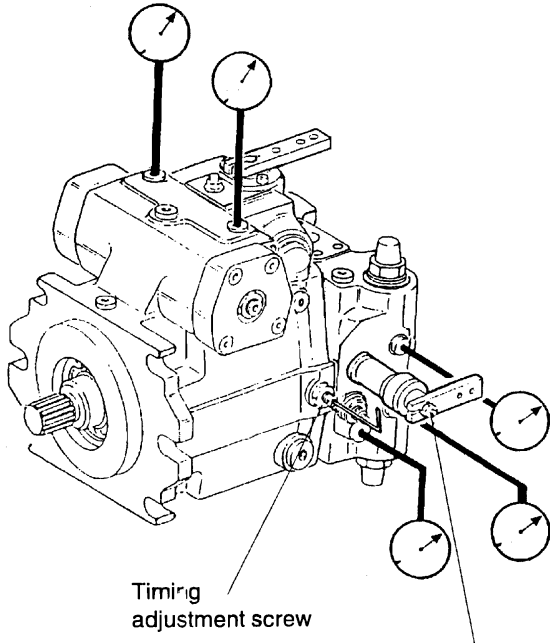

113

**Attention!**  
Observe safety regulations!

Check setting data.  
Operating temperature should be kept largely constant during the check procedure.  
Start prime mover, idle speed.

**Block position**  
Drive direction switch - "0".  
Slowly increase motor speed up to the max. motor speed and thereby observe measuring instruments.

**Boost pressure:**  
Idle speed of prime mover  
Psp = approx. 15 - 20 bar  
max. motor speed  
Psp = ..... bar\*

**Block position**  
Drive direction switch - **forward**  
(Road gear and fully applied brake)

Check setting data pump A4VIDA  
**Begin of control:**  
HD 40 - 50 bar  
Motor speed ..... rpm\* Psp ..... bar\*  
HD ..... bar\*  
Readjusting - control start screw

**End of control**  
HD ..... bar  
Motor speed ..... rpm\* Psp ..... bar\*  
Readjusting timing adjustment screw

**Note:**  
Eccentric adjusting - observe direction of rotation

\* Setting data according to order!

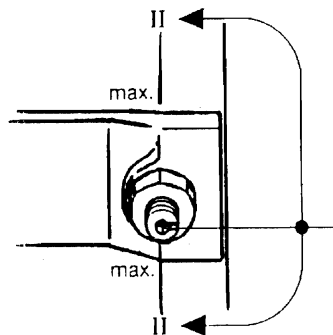

114

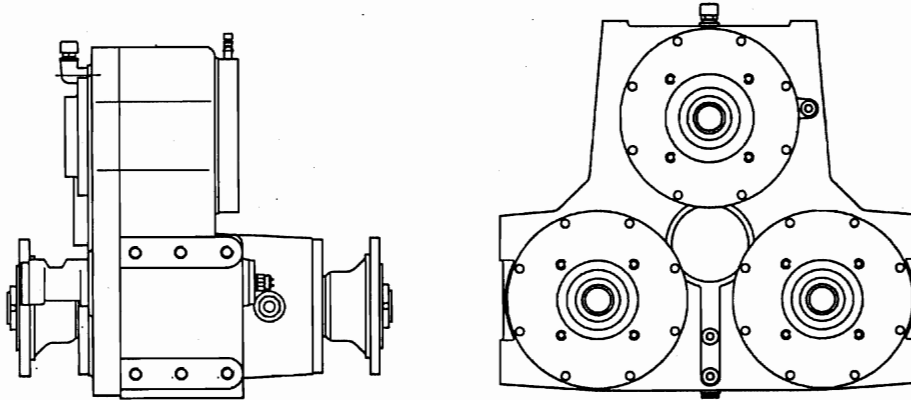

## Contents

1. Technical data
2. Forward
3. Prescribed use
4. Transport and storage
5. Set-up and putting into operation
6. Conversions and modifications
7. Maintenance
8. Spare parts and repairs
9. Lubricants

## 1. Technical Data

STIEBEL D51545 WALDBROEL

Typ 4400.02.09904.97-

Nr. 459005

kW  $n_1$  min<sup>-1</sup>

T<sub>2</sub> Nm  $i = 1:1,6289$

Bj. 1997 kg

GETRIEBEOEL 8.50L

CLP220 DIN51517

## 2. Foreword

These operating instructions contain important advice on the safe, correct and economic operation of the gear and plant.

Following this advice helps to prevent hazards and damage, reduce repair costs and breakdown times and to increase the reliability and service life of the gear.

**Important:** Always read information marked with this  symbol. Such information warns of danger. Non-observance can lead to personal injury and damage to property.

**Advice:** The content of these operating instructions are protected by copyright. Illustrations, drawings and data from these operating instructions may be neither reproduced nor communicated or made available to third parties or competing companies (Para. 48 of the copyright law of 11th June 1870).

## 3. Prescribed Use

The above-mentioned product is intended for installation in a machine. It may not be commissioned until it has been ascertained that the machine in which the above-mentioned product is to be installed complies with the conditions of the EC guideline on machinery.

The product may only be used for the technically designed purpose agreed. The product may not be operated with outputs, torques or external loads which exceed the structural design (see technical data and catalogue).

Installation and commissioning may only be carried out by properly qualified personnel.

Any applicable national, local and plant-specific conditions and requirements concerning the prevention of accidents must be observed.

Qualified personnel are those persons who, on the basis of their training, experience and instruction, along with their knowledge of relevant standards, conditions, regulations for the prevention of accidents and operating conditions, have been authorized by the person responsible for the safety of the plant to carry out the necessary activities and in so doing are able to detect and prevent possible hazards.

## 4. Transport and Storage

### Transport

 For risk-free handling, the hoisting lugs and pegs or threaded bore-holes provided must be used. Hoisting lugs and similar aids attached to the gears are designed only for the weight of the gear and may not be used for raising extension components such as motors, drum shafts or similar. Only use suitable and technically faultless lifting equipment and load suspension devices (e.g. ropes, eye bolts etc.) with sufficient load-bearing capacity. See indication of weight in the technical data or on the type plate. The indications of weight must be regarded as approximate as weights can vary slightly, e.g. by different oil levels. Do not remain or work under suspended loads.

### Storage

Storage from delivery to commissioning should be in dry, dust-free and vibration-free. Enquiries should be addressed to the manufacturer in the case of differing storage conditions.

### Protection against Corrosion

The standard preservation of the shafts, hollow shafts etc. is effective for one year maximum under the above-mentioned conditions. It is not suitable for outside storage.

## 5. Set-up and putting into operation

Assembly and commissioning may only be carried out by suitably qualified personnel.

 Before commissioning and the test run it must be ensured that the moving and rotating components (e.g. shafts, couplings etc.) do not represent a hazard. This means that the necessary contact protection must be provided or measures taken to ensure a safe distance from the machine is maintained. During the test run without attached machinery,

the keys in the shaft ends are to be secured against being spun out.

 Before work on the gear unit or attached equipment is performed, the power supply must be disconnected. Action must be taken to prevent the power being inadvertently switched on again. Where necessary, mechanical devices (special equipment, supports etc.) must ensure that the machine cannot move or rotate.

 It must be ensured before commissioning that the specified amount of lubricant has been poured into the machine. For the oil quantity and oil grade, see nameplate or operating manual. Check the oil level by undoing the overflow screw or by using the oil dipstick or oil sight glass if these devices are fitted.

 Never operate without a breather filter otherwise the excess pressure resulting from the gear unit heating up will cause an oil leak.

 After prolonged operation the lubricant and gear unit surface may reach temperatures which could cause skin burns.

 Oil mist is produced in the gear units. It is therefore dangerous to work with a naked flame near the gear unit openings. There is a risk of fire or explosion.

 High-speed machines into which these gear units are installed may generate loud noises which can damage your hearing if they persist. In this case the operating staff should be provided with ear protection. In order to reduce the noise, all technical possibilities should be used to observe the statutory regulations.

 It must be ensured that the gear units are not continuously subjected to severe vibrations, e.g. from low-speed diesel engines.

#### Technical information

Housings: Torsionally rigid housings made of aluminium or grey cast iron

Gearing: casehardened, tooth flanks ground

Lubrication: Splash lubrication, pressurised circulation lubrication

#### Assembly of the gear units

Before assembly, check the surfaces, edges of the shaft end, keys and external shaft splines for damage, and remedy any damage discovered.

In the case of key and splined shaft connections apply lubricating paste (e.g. Optimol White T) to the shaft end. The paste facilitates assembly of the units and prevents corrosion which would make subsequent dismantling much more difficult. It must be ensured that the shaft seals are not dirty, damaged or coated with paint. When the units are being painted, cover the seals and running surfaces of the shafts or protect with grease. This is the only way to prevent damage and thus oil losses.

Oil baffle plates which may be installed on the pump mounting flanges must not be damaged or dismantled.

#### Assembly of input and output elements

Couplings, belt pulleys or similar elements should be mounted with the appropriate jigs (threaded spindle which is screwed into the centring bore of the shaft). Severe hammering must be avoided as antifriction bearings, retaining rings and other internals would be damaged!

Hydraulic pumps must be connected with the mounting flanges so that they are oil-tight and must not exert any axial pressure on the gear unit shafts! The coupling elements and the splines

must be adequately lubricated before assembly; we recommend Optimol White T or Staburags NBU 30 PTM. Exception: Splined hollow shafts which have their own oil filling from the gear unit lubrication system; the relevant mounting flange is then provided with screw plugs for the oil level and oil drain as well as a breather. In these cases the oil level as well as the oil quantity required to fill the gear unit flange is entered in the assembly drawing.

#### Lubricants

The gear units are as a rule supplied without oil; they are then provided with a label "Caution! Not filled with oil!". Normally gear oil CLP220 to DIN 51517 (mineral oil) or PGLP 220 to DIN 51502 (synthetic oil) is used. These grades are suitable for normal operating conditions at an ambient temperature of -5° to +35°C or -25° to +80°C with synthetic oil. Consult the manufacturer in the event of special operating and application conditions.

#### Commissioning

Before commissioning, the gear units and, if necessary, the mounting flanges must be properly filled with oil; for the oil grade and oil level, refer to the technical data or the nameplate and assembly drawing. During commissioning the plant must not be operated immediately at full capacity. Only after 3-4 hours is the load to be slowly increased so that the plant can then be run under full load. Oil and gear unit temperatures up to 80°C, or up to 100°C with synthetic oil, are not unusual and do not have any negative impact on the functioning of the gear units. The oil level is to be checked after about 15 min. running time as oil collects in the mounting flanges or is dammed there to lubricate the splined hollow shafts. If necessary, replenish oil up to the specified oil level mark. We recommend you to repeat this procedure until the oil level no longer changes. This is especially important if oil pumps, oil coolers and the like also have to be filled with oil.

#### Installation positions

Stiebel power take-off, pump power take-off and variable-speed gear units can be operated in several installation positions depending on the type. The manufacturer must always be consulted in the event of installation positions which deviate from the position ordered or shown in the assembly drawing.

#### Power take-off variable-speed gear units

 The gear units must not be switched under load; this operation may only be performed at standstill. Any contravention of this will result in damage to the geared coupling and no claims under the guarantee will be accepted.

- Pneumatic gear-shifting: The pneumatics must be designed so that the side subjected to pressure is continuously under a pressure of 6 bar. A mist oiler must be installed in the pneumatic system to ensure proper lubrication of the operating piston and to protect it against any corrosion.

- Mechanical gear-shifting: A spring element (gear-shifting aid) must be installed in the shift linkage so that, if the geared coupling in the gear unit is in an unfavourable position (tooth on tooth), the shift linkage can be locked. When the motor starts up, the coupling then engages. The tensile and compressive forces of the shift linkage in the engaged condition must not exceed 500 N.

## 6. Conversions and modifications



Do not make any changes, provide attachments or perform conversion work on the gear unit or components which could reduce safety without the manufacturer's permission! In par-

ticular any protective facilities provided (e.g. covers, overload protection) must not be removed or changed.

## 7. Notes on maintenance





Change oil regularly in accordance with the operating manual. Refer to lubrication chart, pump power take-off gear units. If the mounting flanges have their own oil filling, it is designed as long-life lubrication and no oil change is necessary. For the oil quantity and oil grade, see nameplate or operating manual; the oil quantities are to be regarded as approximations. The oil level indicated in the assembly drawing is always decisive. Check the oil level by undoing the overflow screw or by using the oil dipstick provided these devices are part of the fittings. At each oil change check all the seals and screw fittings for any leaks and, if necessary, retighten the screws. If possible, a visual leak check should be made every day. A rise in the oil level in the gear unit or mounting flanges with their own oil filling is a sign of defective seals in the hydraulic units.

Premature gear unit failure may occur as a result of running dry caused by oil loss, the ingress of water into the gear unit housing or the presence of foreign matter in the lubricant.

-  When changing, replenishing or draining the oil or when taking oil samples, it must be guaranteed that no oil can escape onto the ground, penetrate the ground or surface water or enter the sewage system.
-  Prolonged contact with lubricants can cause injury to your skin. Use a protective skin ointment.
-  After prolonged operation the lubricant and surface of the gear unit may reach temperatures which can cause skin

burns. When working on hot components, wear protective clothing, e.g. protective gloves.



The lubricant is best drained while still warm from operation so that a complete change of the old lubricant is ensured. If the oil is highly contaminated, the gear unit should be rinsed with the same lubricant.

-  Under no circumstances may different types of lubricant, such as mineral oil, synthetic oil or grease, be mixed with each other.
-  The applicable national, local and plant-specific regulations and requirements concerning accident prevention and environmental protection are to be observed.
-  To prevent faults, it is necessary to carry out the regular maintenance and inspection work prescribed. Any changes compared with normal operation (higher power input, temperatures or vibrations, unusual noises or smells, response of monitoring devices etc.) are an indication that the unit is not functioning properly. To avoid faults which could result in injury to people or damage to property, the maintenance staff responsible must be notified immediately. In case of doubt switch off the relevant item of equipment and ensure it cannot be switched on again.
-  To prevent damage from overheating, dirt and dust deposits should be regularly removed from the gear unit surface.

## 8. Spare parts and repairs

Spare parts must satisfy the technical requirements specified by the manufacturer. This is always guaranteed with original spare parts. When ordering spare parts, the type number and serial number (to be found on the nameplate or in the technical data) in addition to the spare part number must be indicated. Spare parts drawings and spare parts lists can be requested from the manufacturer.

Repairs and overhauls are carried out by the manufacturer at short notice. When carrying out your own repairs, make sure that the expendables and auxiliary materials and parts which have been replaced are disposed of safely and without polluting the environment.

-  The applicable national, local and plant-specific regulations and requirements concerning accident prevention and environmental protection are to be observed. The manufacturer does not assume any liability for damage caused by improper repair work or the use of non-original spare parts.
-  Prolonged contact with lubricants can cause skin damage. Use a protective skin ointment. After prolonged operation the lubricant and the surface of the gear unit may reach temperatures which can cause skin burns. Before starting repairs, let the gear unit cool down.



THIS PAGE INTENTIONALLY LEFT BLANK.

**REED**CONCRETE PLACING  
EQUIPMENT**CRK WASH WATER PUMP**

VENDR

FIGURE 07

PAGE 01

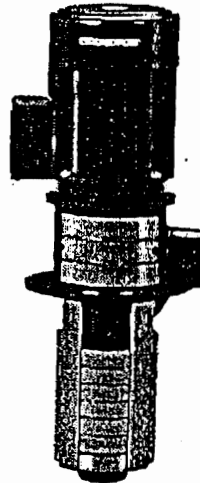
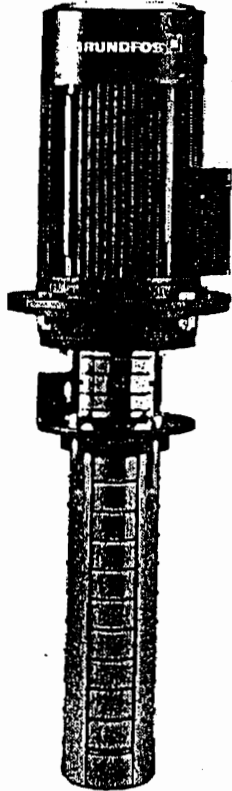

- Ⓒ GB Installation and Operating Instructions
- Ⓒ D Montage- und Betriebsanleitung
- Ⓒ F Notice d'Installation et d'entretien
- Ⓒ DK Monterings- og driftsinstruktion

**CRK****CONTENTS**

1. Applications
2. Type Designation
3. Operating Conditions
4. Installation
  - 4.1 Pump Location
  - 4.2 Suction Conditions
5. Electrical Connections
6. Start-Up
7. Operation and Maintenance
  - 7.1 Lubrication and Maintenance
  - 7.2 Filters
  - 7.3 Periodic Checks
8. Fault Finding Chart



**1. Applications**

The GRUNDFOS CRK pumps are multistage centrifugal pumps designed for the pumping of cooling and cutting liquids for machine tools, condensate transfer, liquid transfer in industrial washing machines and similar applications.

CRK pumps are designed for the pumping of liquids with a density and viscosity corresponding to those of water. The pumped liquid must not contain abrasive particles or fibres.



When pumping liquids with a density or viscosity higher than that of water, motors with correspondingly higher outputs must be used, if required.

**2. Type Designation**

The standard range of CRK pumps encompasses complete impeller in chamber combinations. On request, other lengths, against duty combinations, can be supplied by fitting empty intermediate chambers instead of standard chambers with impellers.

The pump key on the pump nameplate indicates the number of chambers and impellers fitted to the pump.

Example:

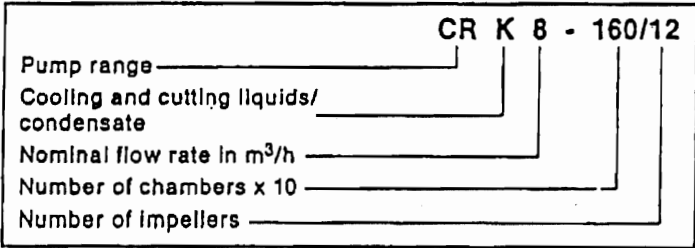

**3. Operating Conditions**

- Liquid Temperature: - 15°C to + 90°C.
- Ambient Temperature: - 30°C to + 40°C.
- Enclosure Class: IP 55.
- Relative Air Humidity: Maximum 90%.
- Operating Pressure: Maximum 25 bar.

### 4. Installation

#### 4.1 Pump Location

The pump is designed for tank mounting in a vertical position. The pump is positioned in a hole cut into the cover of the tank (upper side) and is secured to the tank by four set screws through the holes in the mounting flange. It is recommended to fit a sealing gasket between the pump flange and tank.

GB

Fig. 1

Pump Mounting Flange Dimensions

	CRK 2 and 4	CRK 8 and 16
D1	160	225
D2	140	200
D3	180	250
L	100	125
Rp	1¼	2
X	ø7	ø9

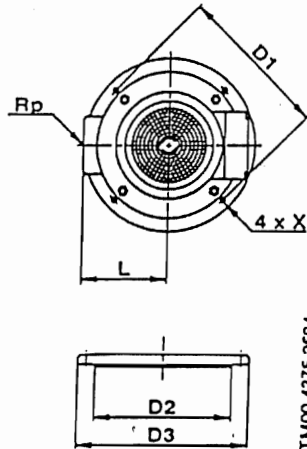

TM00 4375 2594

#### 4.2 Suction Conditions

The CRK pumps are designed to provide full performance down to a liquid level of 40 mm (CRK 2/4) or 50 mm (CRK 8/16) above the bottom of the pump strainer.

At a liquid level between 25 and 40/50 mm above the bottom of the strainer, the built-in priming screw will protect the pump against dry-running, see fig. 2.

Fig. 2

CRK 2 and CRK 4

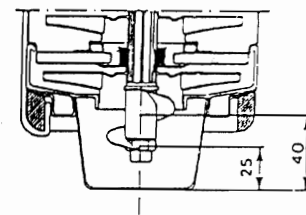

TM00 4376 2594

CRK 8 and CRK 16

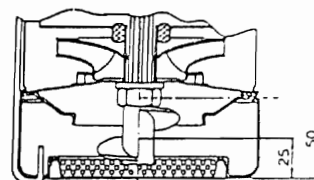

TM00 4256 2294

### 5. Electrical Connections

The electrical connections should be carried out in accordance with local regulations.

The operating voltage and frequency are marked on the pump nameplate. Please make sure that the motor is suitable for the electricity supply on which it will be used.

Single-phase GRUNDFOS motors incorporate a thermal switch and require no additional motor protection.

Three-phase motors must be connected to a motor starter.

To ensure easy access to the electrical connections, the terminal box can be turned to the positions shown in fig. 3.

Remove the coupling guards which are kept in position by spring tension.

To change the position of the terminal box, remove the four screws securing the motor to the motor stool. Turn the motor to the required position, replace and tighten the four screws.

Replace the coupling guards.

Do not start the pump until it has been submerged in the pumped liquid. ...

The electrical connection should be carried out as shown in the diagram inside the terminal box cover.

In the case of **frequency converter** operation, the motor should not be loaded by more than 90% of the power stated on the motor nameplate, unless otherwise stated by the frequency converter manufacturer.

### 6. Start-Up

The pump can be started against an open or a closed discharge side.

- If the discharge side is open and the pump body is partly filled with liquid when the pump is started, the air will escape through the discharge pipe.
- If the discharge side is closed and the pump body is partly filled with liquid when the pump is started, the air will be pressed down through the pump body and out into the tank, and the pump will very quickly reach its maximum operating pressure.

Fig. 3

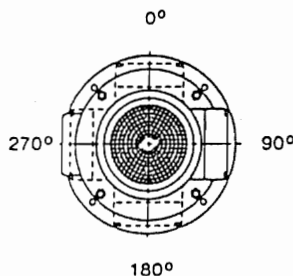

TM00 4257 2294



Before starting the pump, make sure:

1. that the direction of rotation of the pump is correct.

**When seen from the top, the pump should rotate counter-clockwise.**

(Start the pump for a short period and check the direction of rotation at the motor cooling fan).



2. that all pipe connections are tight.
3. that the pump body is partly filled with liquid (partly submerged).
4. that the strainer is not blocked by impurities.

## **7. Operation and Maintenance**

### **7.1 Lubrication and Maintenance**

Pumps installed in accordance with these instructions require very little maintenance.

The mechanical shaft seal is self-adjusting and has wear-resistant seal rings which are lubricated and cooled by the pumped liquid.

The pump bearings are also lubricated by the pumped liquid. Motor bearings are grease packed and sealed for life. No further lubrication is necessary.

### **7.2 Filters**

Chip trays, filters, etc. should be cleaned at regular intervals to ensure a correct flow of liquid.

### **7.3 Periodic Checks**

At regular intervals, depending on the conditions and time of operation, the following checks should be made:

- Check the quantity of liquid and operating pressure.
- Check that there are no leaks.
- Check that the motor is not overheating.
- Check the tripping of the motor starter.
- Check that all controls are operating satisfactorily.

If the above checks do not reveal any abnormal operating details, no further checks are necessary. Should any faults be found, check the symptoms with section 8. "Fault Finding Chart".

**8. Fault Finding Chart**

Before removing the terminal box cover and before any removal/dismantling of the pump, make sure that the electricity supply has been switched off.

Fault	Cause
1. Motor does not run when started.	a) Supply failure. b) Fuses blown. c) Motor starter overload has tripped out. d) Main contacts in starter are not making contact or the coil is faulty. e) Control circuit fuses are defective.
2. Motor starter overload trips out immediately when supply is switched on.	a) One fuse is blown. b) Contacts in motor starter overload are faulty. c) Cable connection is loose or faulty. d) Motor winding is defective. e) Pump mechanically blocked.
3. Motor starter overload trips out occasionally.	a) Overload setting too low. b) Periodic supply failure. c) Low voltage at peak times.
4. Motor starter has not tripped out but the pump does not run.	a) Check 1 a), b), d) and e).
5. Pump capacity not constant.	a) Pump strainer partly blocked by impurities. b) Liquid level in tank too low. See 4.2 "Suction Conditions".
6. Pump runs but gives no liquid.	a) Pump strainer blocked by impurities. b) Liquid level in tank too low. See 4.2 "Suction Conditions". c) Pump rotates in the wrong direction.



**OPERATING INSTRUCTIONS****PNN**<sup>®</sup>  
SYSTEM*PNN BUS.3 PNN BUS.5**Nano Nano Vario  
Nano S.A2.HC***1. STANDARD SPECIFICATION**

- Portable transmitter with two replaceable 7,2 volt NiCd batteries, halter and waist straps
- Receiver with NBB adapter plate for fastening purposes (Only PNN-BUS-3)
- Receiver with 4 fastening angles (PNN-BUS-5)
- Multi-pole connecting cable for the receiver, to your specifications
- Automatic battery charger with charging adapter (rapid charging in three hours)

**The actual delivery specification is as detailed on the confirmation of order or the delivery note accompanying the goods!**

## 2. SAFETY PRECAUTIONS

Even if you are accustomed to working with radio control systems, read these operating instructions without fail before using this equipment. Only this document contains the latest information relating to your NBB radio control system.

Please refer to the accompanying registration documents for the explanatory notes on obtained an operating permit. Observe all applicable work-safety and accident prevention regulations without fail. Only fully trained, authorized personnel may use the NBB radio control equipment. Components, etc. built into the NBB equipment for safety purposes must be regularly inspected. (See point 6 of this instruction)

**If the NBB radio control unit develops a fault, it must be shut down immediately. The transmitter should be switched off with the EMERGENCY-OFF switch. The connecting cable must be disconnected from the crane connecting socket (terminal) on the receiver. The repair of the equipment must not be carried out other than by NBB or an NBB authorized technician.**

Failure to observe these recommendations will put both you yourself and others at risk. Under these circumstances, NBB rescinds the guarantee and any other form of liability. This radio control unit is designed exclusively for the control of construction machines and industrial plants. Only under these conditions are the safety systems (EMERGENCY-OFF, zero setting) fully effective. No other form of use is permitted. Any non-observance of this condition will relieve NBB of all liability.

Nano, Nano-S-A2-HC



Nano-Vario

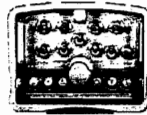

## 3. TRANSMITTER

To make the unit ready for use, insert the battery into the battery compartment. To remove the battery, depress the pin and push out the battery. The power supply to the transmitter is activated with the EMERGENCY-OFF switch (when depressed, the EMERGENCY-OFF switch can also be secured by removing the key cap). The green LED on the transmitter control panel must flash regularly. Commands can now be input by means of the controls. The operating period with a charged battery is approximately 8 hours with the transmitter in continuous use. When the red "Battery" indicator lamp lights up, the battery is nearing exhaustion. The transmitter can be operated for approximately 15 minutes more in this condition. During this time, bring the crane to a safe position and install a new battery.

Removal of the battery interrupts the radio link. As a result, the master switch for the crane must be switched on again.

Charge the discharged battery with the charger supplied.

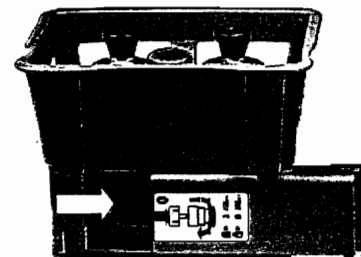

Depress the pin and push out the battery

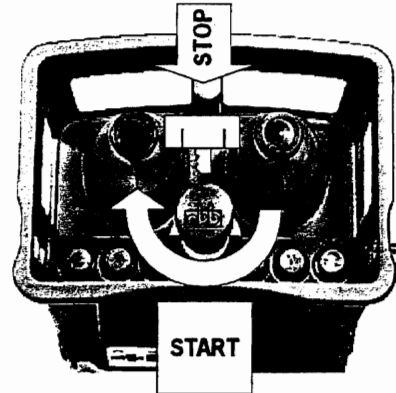

## 4. BATTERY CHARGER

The red indicator lamp indicates that the battery charger is ready for use. Place the battery in the charging well; it will now be charged. When the red LED goes out, the charging process is concluded. No harm will come to the battery if it is left in the charger beyond the required charging time.

**Do not use the charger other than in dry rooms having a min-max temperature range of 0-40°C. A charged battery is a concentrated energy source. Never store a charged battery in a toolbox or similar where it could be short-circuited by metal components (even a key in your trouser pocket can cause a short circuit).**

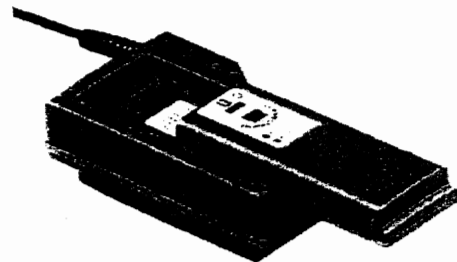

**5. RECEIVER (PNN-BUS-3 and PNN-BUS-5)**

The receiver is connected to the crane with the multi-pole connecting cable supplied. Please observe the instructions issued by the crane manufacturer. The power supply to the receiver is generally effected by way of the connecting cable.

- In general, an earth lead is required in the case of cranes which have not previously been operated under radio control. Failing this, the receiver electronic circuit will not receive any power supply.
- Take care to ensure that the operating voltage of the receiver complies with the electrical specifications of the crane. The applicable operating voltage is specified in the supplement.
- Never expose the receiver to a high pressure cleaning jet. This also applies to the transmitter.
- The receiver should always be fixed vertical at the outside panel of the switching cabinet. The antenna should reach over the top of the panel.

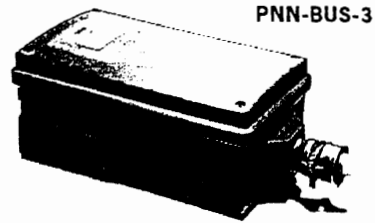
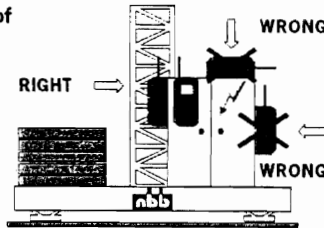

PNN-BUS-3

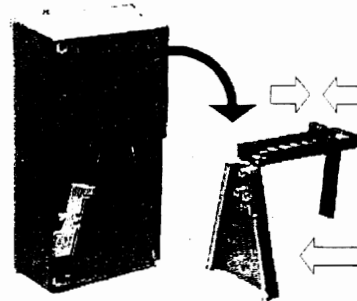
Mounting-possibilities of the PNN-BUS-3  
or of the PNN-BUS-5.

PNN-BUS-5

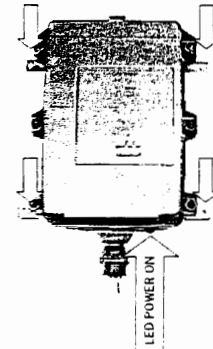

Nano-Vario

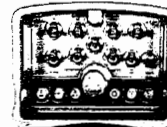

Nano / Nano-S-A2-HC

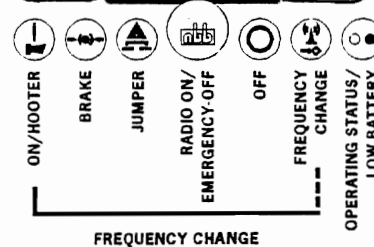
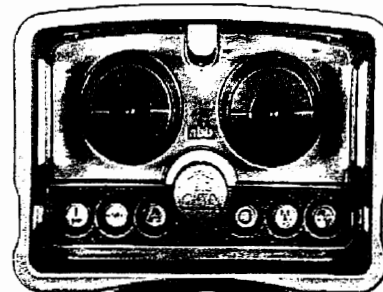
**6. OPERATING THE SYSTEM**

Safety equipment in the NBB radio control system:

- In the transmitter:**
  - EMERGENCY-OFF switch with automatic disconnection from the power supply
  - Automatic zeroing
- In the receiver:**
  - Duplicated 2-channel evaluation of the EMERGENCY-OFF signal
  - Automatic zeroing when switched on again after radio signal interruption
  - Inhibition of radio control commands at the relay level if EMERGENCY-OFF circuit defective.

To ensure troublefree operation, observe the following operating instructions precisely. Subject to the transmitter being in operating condition, the crane's master switch can only be switched on provided no command transmitter is actuated. The necessary command for this purpose is initiated by the 'ON/HOOTER' button. This activates a warning signal on the crane. After the crane has been switched on, this button serves for the subsequent activation of the hooter as required by safety at work regulations.

If the NBB radio control unit remains unused for a prolonged period, we strongly recommend that the battery be charged from time to time (approximately every four weeks). This will prevent it from becoming discharged and will prolong its working life. If an extended period of disuse is intended, we recommend that the battery be removed from the transmitter.

**Changing the frequency:**

To change the frequency, hold down the 'ON/HOOTER' button while simultaneously operating the 'FREQUENCY CHANGE' button until the hooter sounds. (Please observe the accompanying registration conditions, see page 5, point 9).



**TEACH-IN: Individual Setting of Analog Channels (Basic Setting) at Nano Transmitter\*.**  
The output signals of the analog channels can be individually programmed by the transmitter.

**Activate programming mode**



**Select analog function**



**Save "contact point"**



**Save maximum speed**



**Program opposite direction ?**



**Programming of next function ?**



**Check the programmed values**

**Close the programming mode**

The control is ready to operate.

- 1** Set all analog channels to zero position. (potentiometer without automatic release) Insert the TEACH-battery into the battery compartment, release the EMERGENCY-OFF switch and press the "ON/HORN" key. Now the programming mode is activated.
- 2** To determine which analog function is to be programmed, it is sufficient to turn briefly the appropriate master switch fully in the direction of this function.
- 3** Now the "50%/100%" switch has to be turned into the "50%" position. The master switch is now turned until the required "contact point" is reached. To save this value, the "SAVE" ("ON/HORN") key must be pressed at this position.
- 4** The "50%/100%" switch has to be turned into the "100%" position. The upper initial value is saved by turning the master switch until the maximum speed of the function is reached then pressing again the "SAVE" ("ON/HORN") key.
- 5** The opposite direction of this function can then be programmed the same way immediately afterwards. See point **3** and **4**.
- 6** When programming several analog channels consecutively, the "FREQUENCY-CHANGE" key must be pressed once after saving a function. Continue point **2**.

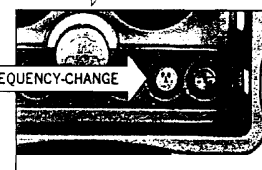
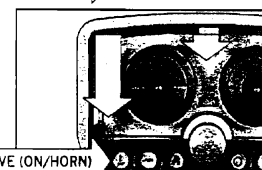
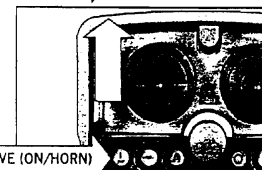
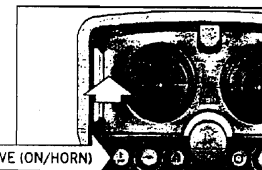
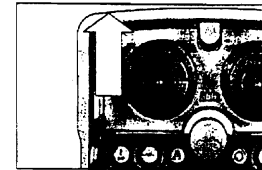
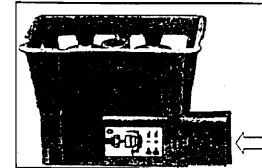

- 7** By pressing and holding the "FREQUENCY-CHANGE" key it is possible to change to the working mode to check the programmed values. As soon as the key is released, the programming mode can be commenced, as described above. (Point **2** to **5**.)
- 8** Press the EMERGENCY-OFF switch, push out the TEACH battery of the battery compartment, insert the normal working battery, release the EMERGENCY-OFF switch again and prepare the control to operate by pressing the "ON/HORN" key.

**Please note:**  
In the programming mode all functions are locked, except "ON/HORN" and each selected function.

\* Please refer to the scope of supply of your facility.

**TEACH-IN: Individual Setting of Analog Channels (Basic Setting) at Nano Transmitter with Potentiometer Control\*.**

The output signals of the analog channels can be individually programmed by the transmitter.

**Activate programming mode**



**Select analog function**



**Save "contact point"**



**Save maximum speed**



**Programming of next function ?**



**Check the programmed values**

**Close the programming mode**

The control is ready to operate.

**1** Set all analog channels to zero position. (potentiometer without automatic release) Insert the TEACH-battery into the battery compartment, release the EMERGENCY-OFF switch and press the 'ON/HORN' key. Now the programming mode is activated.

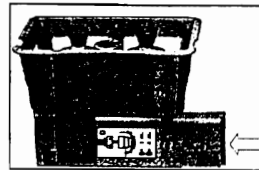

**2** To determine which analog function is to be programmed, it is sufficient to turn briefly the appropriate potentiometer fully in the direction of this function.

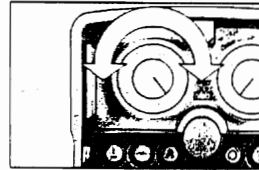

**3** Now the '50%/100%' switch has to be turned into the '50%' position. The potentiometer is now turned until the required 'contact point' is reached. To save this value, the 'SAVE' ('ON/HORN') key must be pressed at this position.

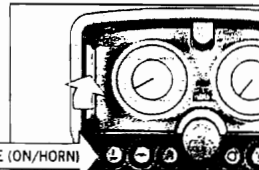

**4** The '50%/100%' switch has to be turned into the '100%' position. The upper initial value is saved by turning the potentiometer until the maximum speed of the function is reached then pressing again the 'SAVE' ('ON/HORN') key.

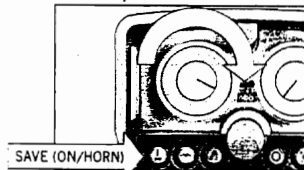

**5** No opposite direction.

**6** When programming several analog channels consecutively, the 'FREQUENCY-CHANGE' key must be pressed once after saving a function. Continue point **2**.

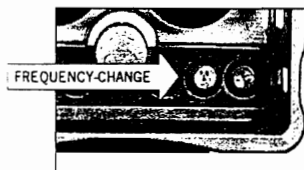

**7** By pressing and holding the 'FREQUENCY-CHANGE' key it is possible to change to the working mode to check the programmed values. As soon as the key is released, the programming mode can be commenced, as described above. (Point **2** to **5**.)

**8** Press the EMERGENCY-OFF switch, push out the TEACH battery of the battery compartment, insert the normal working battery, release the EMERGENCY-OFF switch again and prepare the control to operate by pressing the 'ON/HORN' key.

**Please note:**  
In the programming mode all functions are locked, except "ON/HORN" and each selected function.

\* Please refer to the scope of supply of your facility.

## 7. FUNCTION CHECKS

Regular function checks of the NBB radio control unit are essential to ensure that operating safety is maintained. In the case of a single-shift daily operation, we recommend that the checks be carried out once a week. They can be performed with the aid of the indicator lamps on the receiver. For this purpose, the transmitter must be in operating condition.

- First, connect only the receiver - the transmitter remains switched off.
- Switch on the transmitter by releasing the EMERGENCY-OFF button.
- Now test the command functions (always starting at the lowest stage) and check that the crane responds correctly. In particular, make sure that the danger area is clear of all personnel. **Failure to do so may result in an ACCIDENT.**
- **EMERGENCY-OFF check.** Press the EMERGENCY-OFF button on the transmitter until it locks. The crane's master contactor must drop out after a maximum of 1/2 second.

### Checking the LEDs of the receiver

- **LED1: POWER ON.** If the LED does not light up, check the power supply. If the power supply lead is in satisfactory condition, notify your service centre.
- **LED2: HF AVAILABLE.** Remains lit continuously when the transmitter is switched on.  
(not significant in the case of scanner operation).
- **LED3:** Flashes at regular intervals during fault-free operation. Irregular flashing means that the HF channel is probably disrupted. In this case, select an alternative channel.
- **LED4:** If this LED flashes, the HF channel is disrupted.
- **LED5 (Battery operation):** state of charge of the battery.

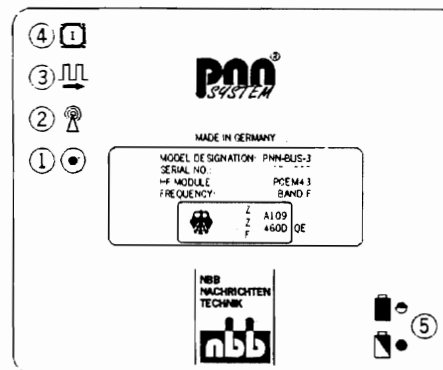

## 8. RATING PLATES

Rating plates contain the serial number, model designation, type of HF module and frequency. In the event of a query, please give the serial number without fail.

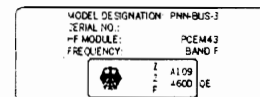

## 9. REGISTRATION

Explanatory notes on obtaining an operating permit for your NBB radio control system will be found in the accompanying registration documents.

## 10. MAINTENANCE

The NBB radio control unit is largely maintenance-free. Nevertheless, please observe the following points:

- The EMERGENCY-OFF button must operate freely.
- Keep the unit clean of any contamination from building materials.
- If any electrical welding is carried out on the crane, disconnect the control cable from the receiver, otherwise the receiver electronics may be damaged.

## 11. GUARANTEE

All NBB radio control units (transmitter, receiver, battery charger) are guaranteed to operate satisfactorily for a period of six months from the date of sale. The terms of the guarantee include parts and labour. Transport costs are the buyer's responsibility. The following are excluded from the guarantee: wearing parts, relays and batteries. The guarantee does not cover damage, accidental damage, negligence, improper use, non-adherence to operating conditions, the non-observance of operating, testing and servicing instructions, or repairs or modifications to the unit not authorized by NBB. NBB will not be liable for consequential damage. It reserves the right to effect repairs or replacements at its own discretion.

## 12. ACTION IN THE EVENT OF A FAULT

Do not continue to work with a defective NBB radio control unit. Even a minor defect in the first instance may eventually lead to a major fault!

Do not try to repair the NBB radio control unit yourself. In the event of a fault, please notify your dealer or contact us!

# TECHNICAL SUPPLEMENT

## NANO: Board E-AN04A2V1/1 TEACH-IN\*

DIL switch (SW2) for setting various transmission characteristics:

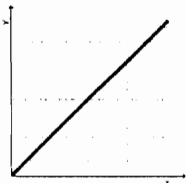

Setting for linear characteristic

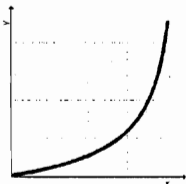

Setting for non-linear characteristic

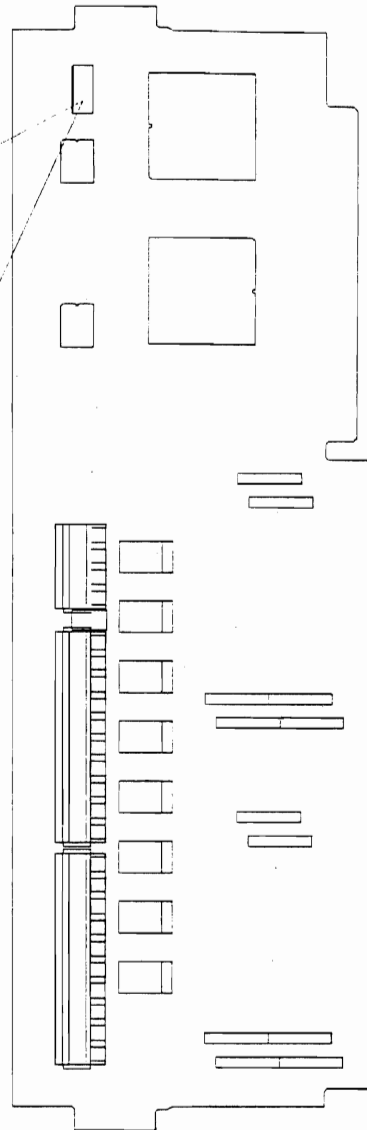
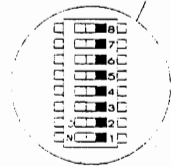
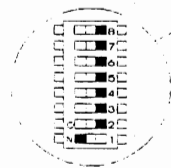

Characteristics  
linear or non-linear

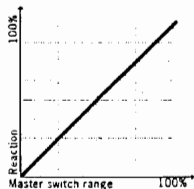

Characteristics in  
Teach-In mode

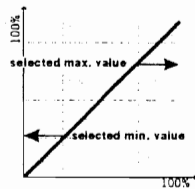

Characteristics after  
Teach-In mode

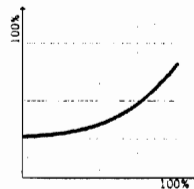
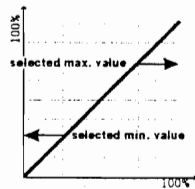
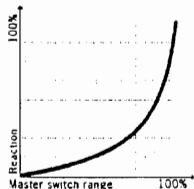
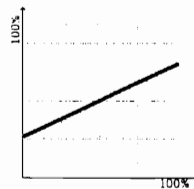

DIL switch no. 8 : OFF : 50% switching variable  
ON : 50% switching fixed

\*Please refer to the scope of supply of your facility.



# REED

CONCRETE PLACING  
EQUIPMENT

## PNN SYSTEM CABLE REMOTE CONTROL

VENDR

FIGURE 08  
PAGE 08

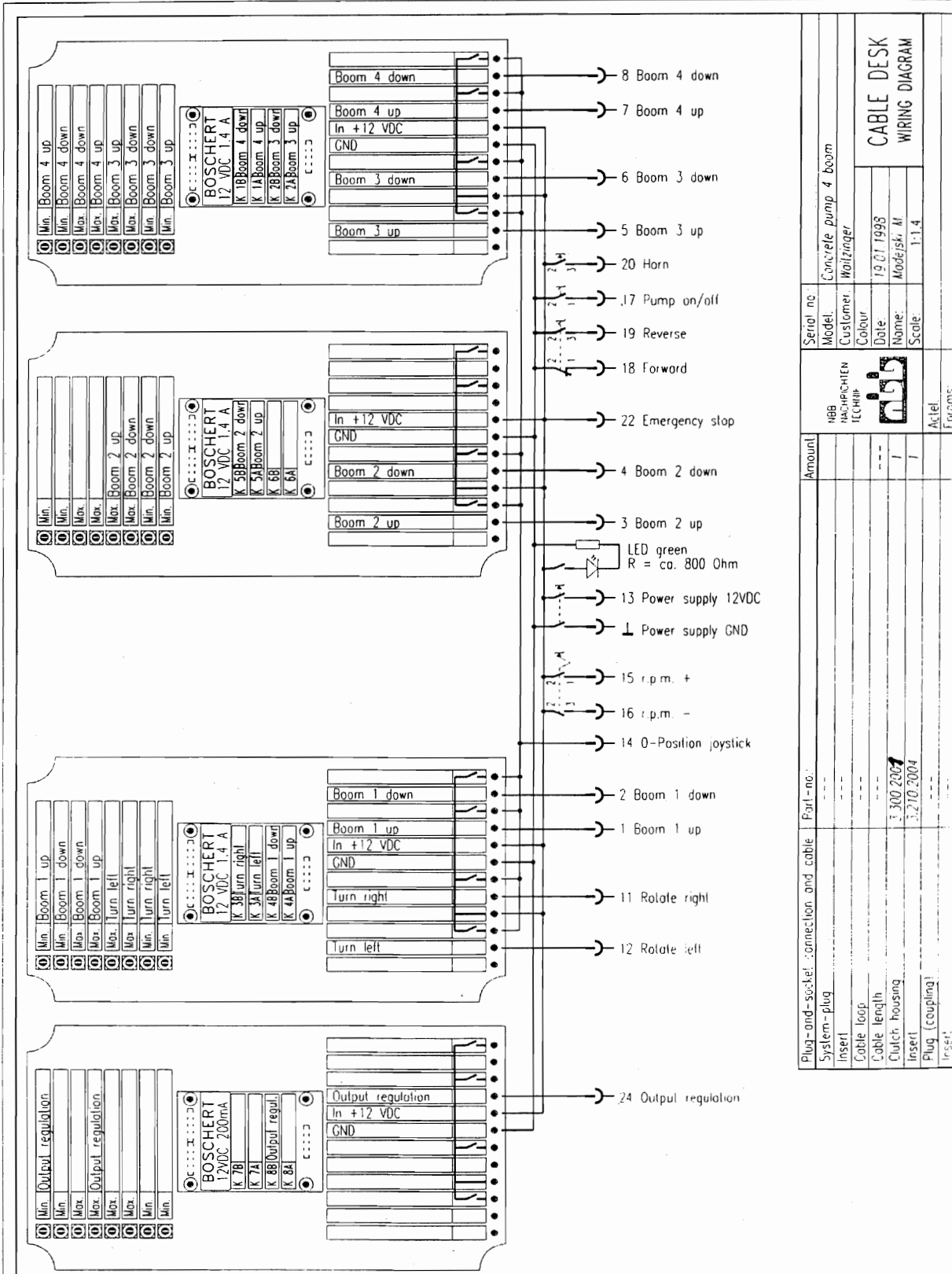

REVISION:



# PNN SYSTEM CABLE REMOTE CONTROL

VENDR

FIGURE 08  
PAGE 09

Anlage 1 zur Zulassungsurkunde  
Nr. G120913F vom 05.10.1995  
Vorgangs-Nr.: 49202  
Seite 1 (2)

### SYSTEMBESCHREIBUNG

Objektbestandteil: Empfangsmodul: E-EM43 AO

- Objektmerkmale:
- Frequenzbereich: 433,05 MHz bis 434,79 MHz
- Betriebsfrequenzbereich: 433,100 MHz bis 434,750 MHz
- Sendeart: F 1 D
- Betriebsart: Simplex
- Spannungsversorgung des Empfängers: 12V, DC
- Antenne des Empfängers: Antennenbuchse
- Anzahl der schaltbaren HF-Kanäle: 67

### BUNDESAMT FÜR ZULASSUNGEN IN DER TELEKOMMUNIKATION



### ZULASSUNGSURKUNDE

Zulassungsnummer: G120913F  
 Zus. Kennzeichen: LED-D  
 Objektbezeichnung: E-EM43 AO  
 Zulassungsinhaber: RRB  
 Nachrichtentechnik GmbH  
 Otto-Mahr-Str. 3  
 D-75248 Ölbrunn-Byrrn  
 Zulassungsort: Allgemeinzulassung  
 Objektart: Funkanlagen für gewerbliche und industrielle Fernsteuerungs-  
 und Fernmeßzwecke

Das Zulassungsobjekt erfüllt die Zulassungsvorschrift BAPF 222 ZV 125, Ausgabe  
Dezember 1954 auf der Grundlage der angewandten technischen Vorschrift T-ETS  
309 220, Ausgabe August 1993

Saarbrücken, den 05.10.1995

Im Auftrag



*Hans Werner Bies*  
Hans Werner Bies

1 Anlage

Bundesamt für Zulassungen in der Telekommunikation, Telegrafstr. 42, D-60119 Frankfurt am Main, (0681) 94-5, fax 0681 94-18 00



**MODEL XT36-160 TRUCK MOUNTED  
CONCRETE BOOM PUMP  
SERVICE BULLETIN**

**XT36-160  
SRVBT**

**PAGE 01**

AS WE MAKE IMPROVEMENTS TO THE **REED** TRUCK MOUNTED  
CONCRETE BOOM PUMP MODEL **XT36-160**,  
WE LIKE TO SUPPLY YOU, THE CUSTOMER, WITH  
UPDATED INFORMATION WHICH APPLIES TO YOUR PUMP.

THIS SECTION IS PROVIDED AS A PLACE TO STORE  
SERVICE BULLETINS AS YOU RECEIVE THEM  
FROM **REED LLC**.

REVISION:





**MODEL XT36-160 TRUCK MOUNTED  
CONCRETE BOOM PUMP  
SERVICE BULLETIN**

**X36-160  
SRVBT**

**PAGE 02**

THIS PAGE INTENTIONALLY LEFT BLANK

BULLETIN NO: SB 001  
DATE: FEBRUARY 5, 1998  
TO: ALL **REED** DEALERS  
SUBJECT: **REED WARRANTY PROGRAM**

Each **REED** Concrete Placing Trailer Pump, Truck Mounted Boom Pump and Dry-mix Spraying Gun, undergoes before delivery a thorough Quality Assurance inspection, a performance check and final testing. However, even with these precautions the possibility exists that after delivery, for some reason, a component may fail.

This is the reason for warranty. If this should happen to one of your machines during the first 12 months or 1000 pumping hours after delivery, there is a good chance the failed component could be replaced under warranty.

**REED** has updated and formalized its **WARRANTY PROGRAM** and this bulletin is issued to make all dealers aware of the program.

Enclosed is a supply of our new **WARRANTY CLAIM** forms. From this point on, all warranty claims must be submitted on these forms. Also, please find a description of the program, coverage and how to make a claim and its submission. We suggest you give this some careful attention. Briefly some noteworthy items are:

- Do not return any failed part unless requested by **REED**.
- Purchase the replacement part through normal channels from **REED**. Submit your claim noting the invoice number of the replacement part. Upon approval of the claim, a credit will be issued.
- Every effort will be made to process claim within 2 weeks from receipt except for those occasions where the part is to be returned.

Should questions arise during your review, please do not hesitate to contact us.

We appreciate the opportunity to be of service.

Sincerely,



Mike Wickstrom  
Service Manage

## **WARRANTY PROGRAM POLICY**

**REED** Concrete Placing Equipment MODEL **XT36-160** is designed and engineered to perform as stated on published specifications. Only quality materials and workmanship are used in the manufacture of these products. As a back up for the product manufactured by **REED**, a guarantee against defects in design and workmanship of components is provided for each machine.

The **REED** guarantee/warranty states, in general, that **REED** will replace free of charge any components found to be defective within the time frame of the warranty period. There are exceptions to some components which are not the responsibility of **REED**. These are noted elsewhere.

A formal printed policy is available and depicts in more detail the warranty and description. However, for your ready reference the following is offered:

### **A. WARRANTY PERIOD**

- ALL CONCRETE PLACING MACHINES

The warranty period is for twelve (12) months from date of delivery to initial user or 1000 pumping hours whichever comes first.

- NEW PARTS WARRANTY

For parts sold through the **REED** Parts Department the warranty is ninety (90) days from invoice ship date.

- REPLACEMENT WARRANTY PARTS

Replacement parts provided under the terms of the machine warranty are for the warranty period applicable to the unit in which they were installed as if such parts were original components of the machine.

### **B. WARRANTY COVERAGE**

- DEFECTIVE PARTS

Unless otherwise authorized the replacement part **MUST** be **PURCHASED** from **REED**. Once warranty claim is received and approved, **REED** will provide credit to the dealer/user for their cost of the replacement part as invoiced by **REED**.

- LABOR

No labor time and related compensation will be provided by **REED** to dealers/users or others to perform work under this warranty policy.

- TRAVEL TIME

No travel time, mileage or other expenses will be compensated by **REED** to dealers/users or others to perform work under this warranty policy.

- FREIGHT, IMPORT DOCUMENTATION, CUSTOM DUTY

Any expense incurred for freight, import duty and documentation will not be reimbursed by **REED** in association with this warranty policy.

### **C. EXCLUSIONS**

- CHASSIS AND RELATED COMPONENTS (TRUCK MOUNTED UNITS)

The warranty for the chassis is handled by the chassis manufacturer and their dealer network. Prior to putting the truck in service it is suggested you contact the nearest manufacturer dealership.

- ENGINE - TRAILER UNITS

The engine warranty is handled by the engine manufacturer and their dealer network. The terms and conditions of their warranty will apply. Contact the local engine dealer for specifics on warranty of the engine.

- NORMAL WEAR

This pertains to items that have failed as a result of normal wear and tear to the product including but not limited to material cylinder and hydraulic cylinder piston components, delivery systems, pins, chains, bushings, seals, concrete pump wear parts, brakes, filter elements, fluids and tires.

- DAMAGES

Caused by transport of equipment or parts, improper set-up or installation, operator error, improper operation or storage, environmental conditions, accidents, improper mechanical techniques employed by anyone or any other cause other than a structural defect in materials or workmanship.

- MAINTENANCE

Caused by failure to perform any scheduled maintenance or routine maintenance as specified in technical manual on any structural or mechanical component.

- MODIFICATIONS

Any non-authorized changes or modifications of any kind to the product. Any modification must be authorized and approved in writing by **REED** Engineering Department.

- ABUSE

Any accidental or intentional abuse of product including but not limited to neglect, loading beyond capacity or any operation of the equipment beyond the limits set forth by **REED** documentation and as depicted in the appropriate technical manual.

#### **D. SUBMISSION OF CLAIM BY DEALER/USER**

Should a component failure be encountered during the warranty period and should it fall within the guidelines of the **REED WARRANTY POLICY** the following procedure is to be followed to claim warranty:

1. REPLACEMENT PART

- Obtain the replacement part by ordering it from the **REED PARTS DEPT.** through normal channels. You will be **INVOICED** for the part.
- If the part has been previously ordered from **REED** and is in your replacement stock inventory you may choose to use that part.

2. COMPLETE THE CLAIM FORM

**REED** has supplied you with a pre-numbered Warranty Claim Form which consists of four (4) parts. This and only this form is **ACCEPTABLE**. **DUPLICATE** copies of the form are **NOT ACCEPTABLE**. If you do not have the proper form, contact the **REED** Service Department. They will send you a supply.



The following instructions are offered for completing the **WARRANTY CLAIM FORM**. Refer to sample of form. Circled numbers on form correspond to items below. **FILL IN:**

1. Date your claim is written
2. Distributor name and address
3. End user name and address
4. Model number of unit affected
5. Serial number of unit affected
6. Date unit was first placed in service
7. Hours (from hour-meter) of operation at time of failure
8. Date when failure occurred
9. Date when unit was repaired
10. Return Authorization number as received from **REED** Service Department. This will only apply when failed component is requested to be returned by **REED**.
11. Date when failed part is shipped back to **REED**
12. List **REED** part number, description of part, quantity and price of part.
13. List **REED** invoice number sent you when replacement part was purchased
14. Briefly describe failure and how it occurred
15. Dealers signature and date

The claim form **MUST BE COMPLETELY FILLED OUT**. Claims lacking specific, accurate information will be returned **UNPROCESSED**. If additional room is needed to describe the failure or to list the parts used, attach a separate sheet and identify those sheets with the **SAME WARRANTY CLAIM NUMBER**.

**3. SUBMITTING TO REED**

When all appropriate data has been entered on the claim and signed, proceed as follows:

- Remove copies of form marked “**DEALER**” (yellow) and “**RETURN AUTHORIZATION**” (green). The Dealer copy is for your records and the Return Authorization copy is to be retained in the event **REED** requests the return of the part.
- Mail the “**REED**” copy (white) and “**ACCOUNTING**” copy (pink) along with any back-up data such as a copy of the replacement part **INVOICE** to **REED**. **DO NOT FAX COMPLETED FORM** and send only **FORM ORIGINALS**.

**E. RETURN OF FAILED COMPONENT**

Depending on the type of part and circumstance surrounding the component failure, the possibility exists that **REED** may request that the failed part be returned to them for investigation and evaluation purposes or to apply for warranty from the manufacturer of the part.

- Upon receipt of your warranty claim and before claim is approved, **REED** will inform you in writing if the part is to be returned. On this correspondence a **RETURN AUTHORIZATION** number will be given to you.
- This number is to be written in the appropriate area on the **RETURN AUTHORIZATION** copy (green) of the warranty form. Include this copy as part of your packing slip. Also write the number on a tag and attach to the part.
- Parts requested to be returned must be shipped back to **REED** within 30 days from issuing of the **RA** number. Failure to do so will cause warranty claim to be **DENIED**.
- Returned parts are to be properly packaged and shipped freight **PREPAID**.
- Any parts received by **REED** without the **PROPER RA** number will be shipped back at **DEALER/USER EXPENSE**.
- If claim is approved and no request to return parts from **REED** has been made, then parts can be discarded.





# SERVICE BULLETIN 001 WARRANTY PROGRAM

## F. APPROVAL/DENIAL OF CLAIM

Every effort will be made to process the warranty claim within 2 weeks from receipt.

- APPROVAL

Once your claim has been approved by **REED**, the pink copy will be forwarded to our Accounting Dept. They in turn will issue a credit against the invoice for the replacement purchased part.

In the meantime a fax or notification will be sent you indicating the claim and the amount approved.

- DENIAL

If your warranty claim is denied for any reason, a fax or notification will be sent to you indicating reasons for denial. Should you have any dispute with the decision, you have the right to have the decision reconsidered. You must present your arguments in **WRITING** within 15 days of your receipt of the claim denial.

<b>REED</b> CONCRETE PLACING EQUIPMENT	<b>WARRANTY CLAIM</b> 13822 OAKS AVENUE CHINO, CA. 91710 909-364-2100	<b>NO.</b> _____			
Distributor Account Number: _____		End User Account Number: _____			
Distributor: _____		End User: _____			
Address: _____		Address: _____			
City: _____		City: _____			
State: _____ Zip Code: _____		State: _____ Zip Code: _____			
Phone: ( ) _____		Phone: ( ) _____			
<b>MACHINE PUMP DATA</b>					
Model _____ Serial No. _____		In Service Date _____			
Hours of Operation _____ Failure Date _____		Repair Date _____			
<small>NOTE - Hold deficient part(s) until requested by REED or until claim is approved. All parts requested to be returned must have a return authorization number provided by REED, shipped freight prepaid. Parts must ship within 30 days from REED request.</small>					
RETURN AUTHORIZATION NO. _____		SHIP DATE _____			
PART NUMBER	DESCRIPTION	QTY.	NET PRICE	TOTAL PRICE	REED REPLACEMENT PART INVOICE NO.
	(12)				(13)
Describe Failure and How it Occurred _____ (14)					
REED comments _____					Claim Approved for \$ _____
REED Use - Claim Approved <input type="checkbox"/> Denied <input type="checkbox"/>					Dealer Signature _____ (15)
Signed _____ Date _____					Date _____

REVISION: