

REED TRUCK MOUNTED CONCRETE BOOM PUMP MODEL XXT 32 ILLUSTRATED PARTS MANUAL CONTAINS THE FOLLOWING GROUPS AND FIGURES:

GROUP 00 HOW TO USE PARTS MANUAL

- FIGURE 00 TABLE OF CONTENTS
- FIGURE 01 HOW TO USE PARTS MANUAL
- FIGURE 02 HOW TO ORDER PARTS

GROUP 10 FINAL INSTALLATION

- FIGURE 00 TABLE OF CONTENTS
- FIGURE 01 FINAL INSTALLATION
- FIGURE 02 DECAL ASSEMBLY

GROUP 20 HOPPER INSTALLATION

- FIGURE 00 TABLE OF CONTENTS
- FIGURE 01 HOPPER INSTALLATION
- FIGURE 02 CENTRAL LUBRICATION SYSTEM
- FIGURE 03 LUBRICATION PUMP ASSEMBLY
- FIGURE 04 HOPPER VIBRATION ASSEMBLY
- FIGURE 05 AGITATOR ASSEMBLY
- FIGURE 06 AGITATOR DRIVE MOTOR ASSEMBLY
- FIGURE 07 HOPPER OUTLET ASSEMBLY

GROUP 30 TANK INSTALLATION

- FIGURE 00 TABLE OF CONTENTS
- FIGURE 01 TANK INSTALLATION
- FIGURE 02 WATER SYSTEM GROUP
- FIGURE 03 WASH WATER PUMP ASSEMBLY
- FIGURE 04 WATER PUMP MOTOR ASSEMBLY

GROUP 40 POWER TRAIN INSTALLATION

- FIGURE 00** TABLE OF CONTENTS
- FIGURE 01** POWER TRAIN INSTALLATION (BEF JUL 1999)
- FIGURE 02** POWER TRAIN INSTALLATION (AUG 1999 ~ MAR 2000)
- FIGURE 03** POWER TRAIN INSTALLATION (APR 2000 ~ FEB 2001)
- FIGURE 04** POWER TRAIN INSTALLATION (AFT MAR 2001)
- FIGURE 05** GEAR PUMP ASSEMBLY
- FIGURE 06** PTO GEARBOX ASSEMBLY

GROUP 50 CONTROLS INSTALLATION

- FIGURE 00** TABLE OF CONTENTS
- FIGURE 01** CONTROLS INSTALLATION (BEF MAY 2000)
- FIGURE 02** CONTROLS INSTALLATION (AFT JUN 2000)
- FIGURE 03** CAB CONTROLS ASSEMBLY
- FIGURE 04** MAIN CONTROLS ASSEMBLY (BEF MAY 2000)
- FIGURE 05** MAIN CONTROLS ASSEMBLY (AFT JUN 2000)
- FIGURE 06** LH SIDE OUTRIGGER CONTROLS ASSEMBLY (BEF MAY 2000)
- FIGURE 07** LH SIDE OUTRIGGER CONTROLS ASSEMBLY (AFT JUN 2000)
- FIGURE 08** RH SIDE OUTRIGGER CONTROLS ASSEMBLY (BEF MAY 2000)
- FIGURE 09** RH SIDE OUTRIGGER CONTROLS ASSEMBLY (AFT JUN 2000)
- FIGURE 10** STATIONARY BOOM CONTROLS ASSEMBLY
- FIGURE 11** CABLED REMOTE CONTROL ASSEMBLY (BEF MAY 2000)
- FIGURE 12** CABLED REMOTE CONTROL ASSEMBLY (AFT JUN 2000)
- FIGURE 13** RADIO REMOTE CONTROL ASSEMBLY (BEF MAY 2000)
- FIGURE 14** RADIO REMOTE CONTROL ASSEMBLY (AFT JUN 2000)
- FIGURE 15** SHUNT ASSEMBLY

GROUP 60 PUMPING TRAIN INSTALLATION

- FIGURE 00** TABLE OF CONTENTS
- FIGURE 01** PUMPING TRAIN INSTALLATION
- FIGURE 02** SWING VALVE ASSEMBLY
- FIGURE 03** TILTING DRIVE ASSEMBLY
- FIGURE 04** TILTING CYLINDER ASSEMBLY
- FIGURE 05** CONCRETE CYLINDER ASSEMBLY
- FIGURE 06** WATER BOX ASSEMBLY
- FIGURE 07** HYDRAULIC DRIVE CYLINDER ASSEMBLY
- FIGURE 08** DRIVE CYLINDER SUB-ASSEMBLY

GROUP 70 FRAME AND SUPPORT INSTALLATION

FIGURE 00	TABLE OF CONTENTS
FIGURE 01	FRAME AND SUPPORT INSTALLATION
FIGURE 02	TURRET ASSEMBLY
FIGURE 03	MOTOR AND REDUCTION ASSEMBLY
FIGURE 04	ROTATION UNIT ASSEMBLY
FIGURE 05	SUPPORT FRAME STABILIZERS ASSEMBLY
FIGURE 06	FRONT LEFT STABILIZERS TELESCOPIC LEG ASSEMBLY
FIGURE 07	FRONT RIGHT STABILIZERS TELESCOPIC LEG ASSEMBLY
FIGURE 08	REAR LEFT SWING OUT LEG ASSEMBLY
FIGURE 09	REAR RIGHT SWING OUT LEG ASSEMBLY
FIGURE 10	STABILIZERS VERTICAL JACK CYLINDER ASSEMBLY
FIGURE 11	SWING OUT CYLINDER ASSEMBLY

GROUP 80 OPTIONAL INSTALLATION

FIGURE 00	TABLE OF CONTENTS
FIGURE 01	OPTIONAL INSTALLATION
FIGURE 02	ACCUMULATOR CHARGE KIT
FIGURE 03	OPTIONAL TOOL KIT ASSEMBLY

GROUP 90 BOOM INSTALLATION

FIGURE 00	TABLE OF CONTENTS
FIGURE 01	BOOM INSTALLATION
FIGURE 02	FIRST BOOM ASSEMBLY
FIGURE 03	SECOND BOOM ASSEMBLY
FIGURE 04	THIRD BOOM ASSEMBLY
FIGURE 05	FOURTH BOOM ASSEMBLY
FIGURE 06	FIRST BOOM CYLINDER ASSEMBLY
FIGURE 07	SECOND BOOM CYLINDER ASSEMBLY
FIGURE 08	THIRD BOOM CYLINDER ASSEMBLY
FIGURE 09	FOURTH BOOM CYLINDER ASSEMBLY
FIGURE 10	CONCRETE DECK PIPELINE ASSEMBLY
FIGURE 11	CONCRETE BOOM PIPELINE ASSEMBLY



MODEL **XXT 32** TRUCK MOUNTED CONCRETE BOOM PUMP HOW TO USE PARTS MANUAL

XXT 32
PARTS
GROUP 00
FIGURE 01
PAGE 01

I. PURPOSE

This parts manual is prepared, issued and/or revised by **REED** Manufacturing, for the exclusive use of its customers and is intended for use in provisioning, requisitioning, storing and issuing replaceable **REED** truck mounted concrete boom pump model **XXT 32**. The contents are proprietary to **REED** and are subject to change without notice. The use of any part of this document by any other person or persons or for any other purpose without the written consent of **REED** is expressly prohibited. In addition, **REED** expressly disclaims any and all responsibility arising in or any way related to such **REED'S** prior written consent thereto.

The parts number content of this document, arrangement and breakdown sequence of items is compatible with Military Standard (**MS**) and Air Transport Association Specification (**ATA**).

II. GENERAL SYSTEM OF ASSEMBLY ORDER - Detailed Parts List (Refer to Next Page)

1. This area refers to the corresponding illustration

MODEL - GROUP - FIGURE - PAGE

A. **MODEL** shows which is **REED'S** model number.

B. **GROUP** should be divided with:

00	MODEL XXT 32 ILLUSTRATED PARTS MANUAL
10	FINAL INSTALLATION
20	HOPPER INSTALLATION
30	TANK INSTALLATION
40	POWER TRAIN INSTALLATION
50	CONTROL INSTALLATION
60	PUMPING TRAIN INSTALLATION
70	FRAME AND SUPPORT INSTALLATION
80	OPTIONAL INSTALLATION
90	BOOM INSTALLATION

C. **FIGURE** belong to the group. Please see page of contents and each group.

D. **PAGE** numbers follow to the right of each figure number.

2. The **ITEM NUMBER** corresponds to the item number shown for the part in illustration. Parts with item number preceded by a dash (such as: -1, -5, -12 etc.) are not illustrated.

3. **PARTS NUMBERS** that carry a **REED** part number.



MODEL XXT 32 TRUCK MOUNTED CONCRETE BOOM PUMP HOW TO USE PARTS MANUAL

**XXT 32
PARTS
GROUP 00
FIGURE 01
PAGE 02**



HYDRAULIC PUMPING ASSEMBLY

**XXT 32
PARTS
GROUP 80
FIGURE 08
PAGE 02**

ITEM NO.	REED'S PARTS NO.	DESCRIPTION					QTY
		1	2	3	4	5	
-1	60-06	Assembly, Hydraulic Pumping (See Group 20, Figure 01 for NHA)					Ref
2	78354	• Cup, Piston					2
3	78444	• Coupler					2
4	78352	• Coupling, Dog bone					4
5		• Bolt 1/2 x 4 (attaching parts)					8
6		• Nut, 1/2 (attaching parts)					8
7	78443	• Bone, Dog					2
8		• Bolt 5/8 x 2					6
9	78442	• Coupler					2
10	78438	• Assembly, Hydraulic Cylinder (See Group 60, Figure 07 for DET)					1
11		• Nut (attaching parts)					16
12		• Washer (attaching parts)					16
13	77617	• Bolt (attaching parts)					16
14		• Elbow, 90 FS6802-16-16					4
15	79343	• Assembly, Hose					2
16	78593	• Fitting, MiniCheck (Port)					2
17		• Elbow, 90 FS6802-06-06					4
18		• Fitting, STR FS6400-06-06					4
19	79344	• Assembly, Hose					2
20		• Elbow, 90 FS6801-06-06					4
21		• Valve, Check					4
22		• Elbow, 90 MBMB90-06-06					4
23		• Clamp					3
24	79326	• Tube, Wire					1
25	79345	• Assembly, Tube					2
26	78417	• Cable					2
27	72010	• Loom, 1/2 Flex					A/R
28		• Pin, 1/4 x 20					4
29	79285	• Cover, Proximity Switch					2
30	78416	• Switch, Proximity					2
31	79327	• Plate, End					1
32		• Washer, 1 Lock (attaching parts)					8
33		• Bolt, 1 x 2 Course (attaching parts)					8

DASH (-) ITEM NOT ILLUSTRATED

REVISION:



REVISION:



MODEL XXT 32 TRUCK MOUNTED CONCRETE BOOM PUMP HOW TO USE PARTS MANUAL

XXT 32
PARTS
GROUP 00
FIGURE 01
PAGE 03



CONCRETE PLACING
EQUIPMENT

HYDRAULIC PUMPING ASSEMBLY

XXT 32
PARTS
 GROUP 60
 FIGURE 06
 PAGE 02

ITEM NO.	REED'S PARTS NO.	DESCRIPTION					QTY
		1	2	3	4	5	
-1	60-06	Assembly, Hydraulic Pumping (See Group 20, Figure 01 for NHA)					Ref
2	78354	• Cup, Piston					2
3	78444	• Coupler					2
4	78352	• Coupling, Dog bone					4
5		• Bolt 1/2 x 4 (attaching parts)					8
6		• Nut, 1/2 (attaching parts)					8
7	78443	• Bone, Dog					2
8		• Bolt 5/8 x 2					6
9	78442	• Coupler					2
10	78438	• Assembly, Hydraulic Cylinder (See Group 60, Figure 07 for DET)					1
11		• Nut (attaching parts)					16
12		• Washer (attaching parts)					16
13	77617	• Bolt (attaching parts)					16
14		• Elbow, 90 FS6802-16-16					4
15	79343	• Assembly, Hose					2
16	78593	• Fitting, MiniCheck (Port)					2
17		• Elbow, 90 FS6802-06-06					4
18		• Fitting, STR FS6400-06-06					4
19	79344	• Assembly, Hose					2
20		• Elbow, 90 FS6801-06-06					4
21		• Valve, Check					4
22		• Elbow, 90 MBMB90-06-06					4
23		• Clamp					3
24	79326	• Tube, Wire					1
25	79345	• Assembly, Tube					2
26	78417	• Cable					2
27	72010	• Loom, 1/2 Flex					A/R
28		• Pin, 1/4 x 20					4
29	79285	• Cover, Proximity Switch					2
30	78416	• Switch, Proximity					2
31	79327	• Plate, End					1
32		• Washer, 1 Lock (attaching parts)					8
33		• Bolt, 1 x 2 Course (attaching parts)					8

DASH (-) ITEM NOT ILLUSTRATED

REVISION:



REVISION:



**MODEL XXT 32 TRUCK MOUNTED
CONCRETE BOOM PUMP
HOW TO USE PARTS MANUAL**

**XXT 32
PARTS
GROUP 00
FIGURE 01
PAGE 04**

4. DESCRIPTION

A. The **INDENTURE SYSTEM** used in the parts list shows the relationship of one part to another. For a given item, the number of indentures depicts the relationship of the item to the components of the item as follows:

1 2 3 4 5

Assembly (or Installation)

- **Detail part of assembly**
- **Sub-assembly**
- **Attaching parts for sub-assembly**
- ● **Detail part of sub-assembly**
- ● **Sub-sub-assembly**
- ● **Attaching parts for sub-sub-assembly**
- ● ● **Detail part of sub-sub-assembly**
- ● ● **Sub-sub-sub-assembly**
- ● ● **Attaching parts of sub-sub-sub-assembly**
- ● ● ● **Detail part of sub-sub-sub-assembly**

B. "See Group 20, Figure 01 For **NHA**"

Identifies the illustrated parts chapter location; indicates where the Next Higher Assembly (**NHA**) of the item shown.

C. "See Group 60, Figure 07 For **DET**"

Identifies the illustrated parts chapter location; indicates where the item and its Detailed Breakdown (**DET**) is shown.

D. "See Group 30, Figure 05 for **REF**" or "See Vendor Chapter For **REF**"

Identifies the illustrated parts chapter where the part is, and if listed and illustrated in Vendor Chapter. It is used as a cross-reference (**REF**).

5. QUANTITY

A. Reference (**REF**) indicates the items that is listed previously in the Next Higher Assembly (**NHA**) and then again in this figure.

B. As Required (**A/R**) indicates the parts that is used in a quantity as required.

C. A number entry indicates the quantity of the part used in its next higher application.

6. Functionally related assemblies are illustrated in phantom (_____) but not listed on the detail parts list page.



MODEL XXT 32 TRUCK MOUNTED CONCRETE BOOM PUMP HOW TO ORDER PARTS

**XXT 32
PARTS**
GROUP 00
FIGURE 02
PAGE 01

- Always give serial number and model of **REED** truck mounted concrete boom pump model: **XXT 32**. (Refer to each unit name plate shown below). NOTE: This manual is being released to cover unit starting with serial number **99 - 181 - XXT 32** to current production. Some components used on earlier units differ from current productions. Where this occurs, the part is identified by a serial number.

REED 13822 OAKS AVENUE CHINO, CA 90710 USA		PHONE (909) 384-2100 FAX (909) 384-2140	CE
MODEL	<input type="text"/>	SERIAL NO.	<input type="text"/>
HYD. PRESSURE	<input type="text"/>	PSI	<input type="text"/>
ELECTRIC MOTOR/ ENGINE SPEED	<input type="text"/>	RPM	<input type="text"/>
VEHICLE WEIGHT (APPROX.)	<input type="text"/>	LBS	<input type="text"/>
			KG

75009A

- Always specify part number and complete name of parts ordered.
 - Turn to table of content in the desired Installation. Refer to main group in which part should be listed.

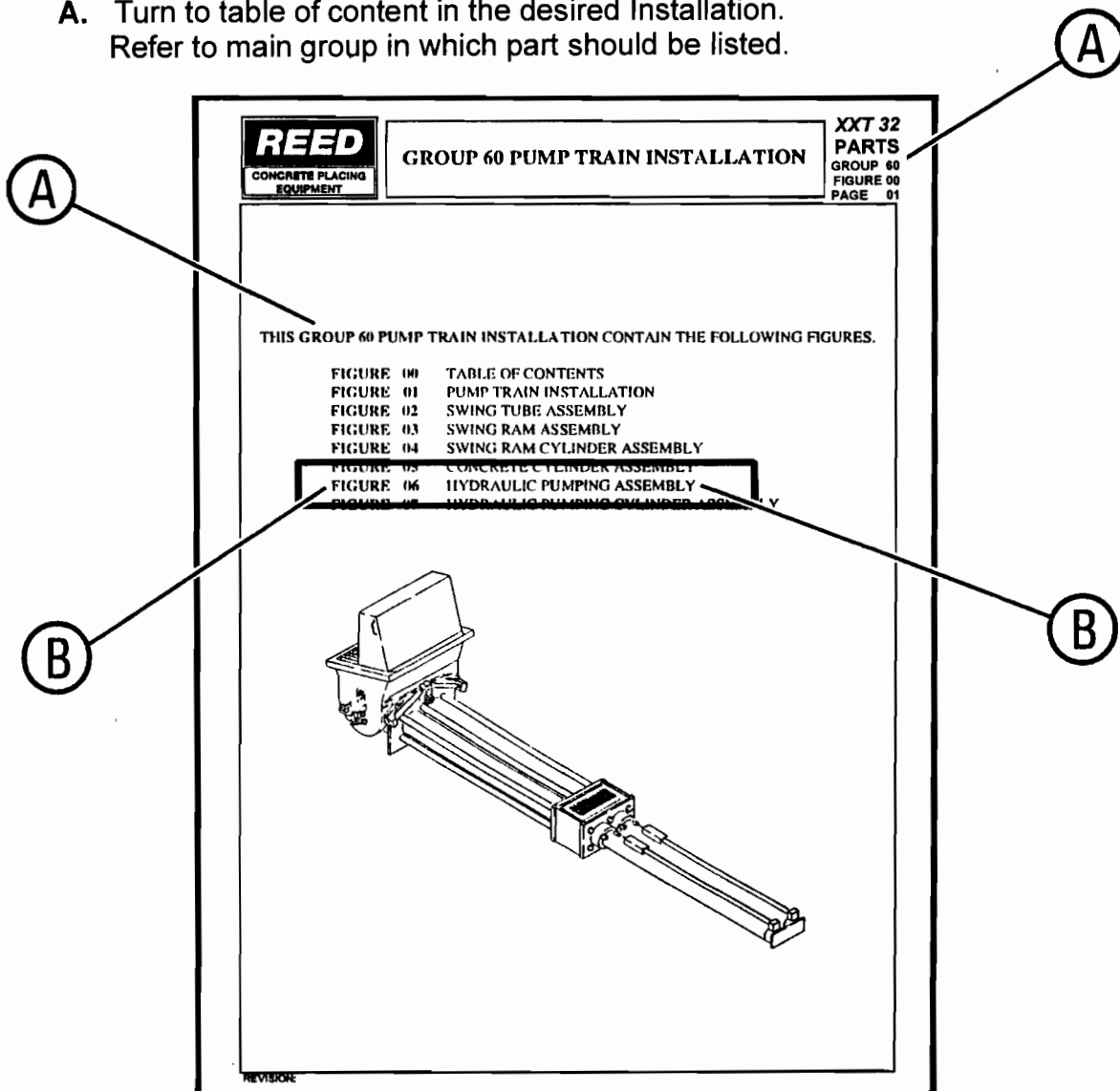

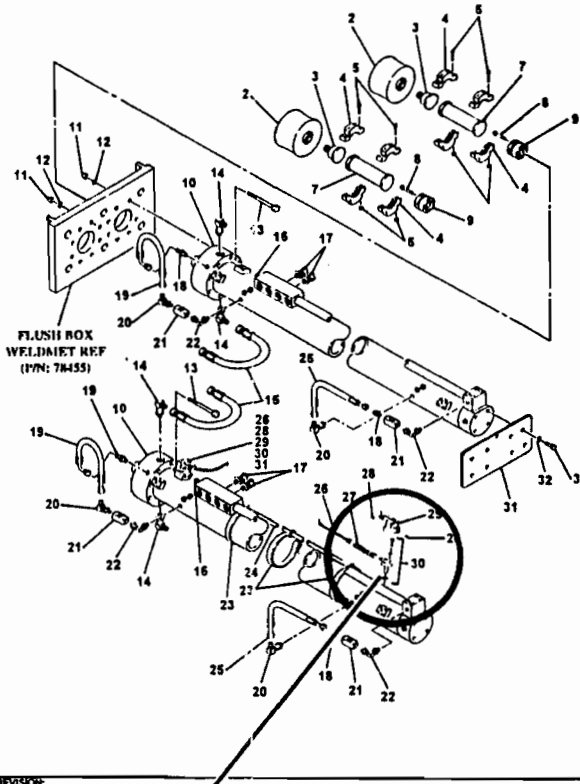

REVISION:

ITEM NO.	REED'S PARTS NO.	DESCRIPTION	QTY
-1	60-06	Assembly, Hydraulic Pump (See Group 20, Figure 1 for NHA)	Ref
2	78354	* Cup, Piston	2
3	78434	* Coupler	2
4	78352	* Coupling, Drag by	4
5		* Bolt 1/2 x 4 (attaching parts)	8
6		* Nut, 1/2 (attaching parts)	8
7	78441	* Hose, Drag	2
8		* Bolt 5/8 x 2	6
9	78442	* Coupler	2
10	78438	* Assembly, Hydraulic Cylinder (See Group 00, Figure 07 for DET)	1
11		* Nut (attaching parts)	16
12		* Washer (attaching parts)	16
13	77617	* Bolt (attaching parts)	16
14		* Elbow, 90 FSA002-16-16	4
15	79343	* Assembly, Hose	2
16	78593	* Fitting, Minicheck (Port)	2
17		* Elbow, 90 FSA002-06-06	4
18		* Fitting, STD FSA0010-06	4
19	79344	* Assembly, Hose	2
20		* Elbow, 90 FSA001-06-06	4
21		* Elbow, Check	4
22		* Elbow, 90 MBM100-06-06	4
23		* Clamp	3
24	79326	* Tube, Wire	1
25	79345	* Assembly, Tube	2
26	78417	* Cable	2
27	72010	* Lawn, 1/2 Flat	A/R
28		* Pin, 1/4 x 20	4
29	79385	* Cover, Proximity Switch	2
30	78416	* Switch, Proximity	2
31	78455	* Flush Box	1
32		* Washer, 1 Lock (attaching parts)	8
33		* Bolt, 1 x 2 Course (attaching parts)	8

DASH (-) ITEM NOT ILLUSTRATED

REVISION:

- B. Find title of figure in which the part should be shown. Note figure number.
- C. Turn to corresponding page, find the group and figure.
- D. Check your required part and its attaching parts and match with illustration page.
- E. Refer to corresponding item number in the part list page. Part numbers are located in the part number column.
- F. When ordering variable or optional miscellaneous parts which are not found this in parts chapter, follow the above outlined procedure of how to order parts.
 - 1). When applicable, give model and serial number of the component for which parts are desired.
 - 2). In a specific, difficult to describe situation, a marked-up photograph or detailed sketch would be helpful.

3. Do not designate quantity by "set". State specifically how many parts are wanted.
4. Always give complete address and full shipping instructions. Specify shipping instructions, truck freight, air freight. United Parcel Service (UPS), or Air Borne Express and DHL are available in designated areas.

5. TO ORDER**A. BY MAIL**

Attention: Parts Department
REED
13822 Oaks Avenue
Chino, CA. 91710

B. BY FAX

(909) 287 - 2141

C. BY PHONE

(909) 287 - 2100

6. Parts return without authorization will not be accepted. If it is necessary to return parts for any reason, written authorization may be obtained from **REED** Parts Department, Chino, CA. 91710-7008. A Parts Return Authorization form is provided when **REED** deems its necessary to have the part returned for evaluation. The form is issued by the Warranty of Parts Department of **REED**.
 - A. The form will be filled by **REED** unless requesting necessary information and you will receive a copy as well as shipping tag.
 - B. Attach shipping tag to part insert return original invoice.
 - C. Ship part to **REED PREPAID**.
 - D. Part must be returned to **REED** within 30 days from date of authorization.

REED TRUCK MOUNTED CONCRETE BOOM PUMP MODEL **XXT 32**
ILLUSTRATED PARTS MANUAL GROUP 10 FINAL INSTALLATION CONTAINS
THE FOLLOWING FIGURES:

- FIGURE 00** TABLE OF CONTENTS
- FIGURE 01** FINAL INSTALLATION
- FIGURE 02** DECAL ASSEMBLY

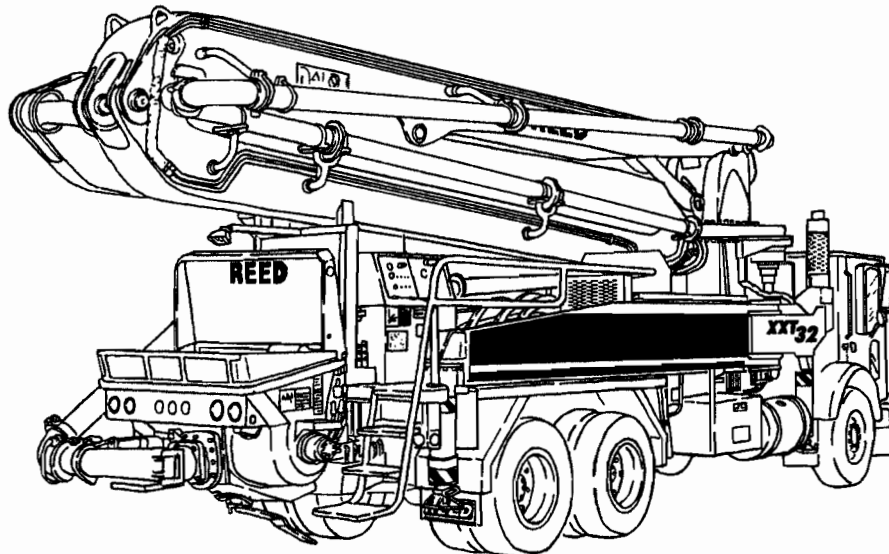



XXT 32 FINAL INSTALLATION

XXT 32
PARTS
GROUP 10
FIGURE 01
PAGE 01

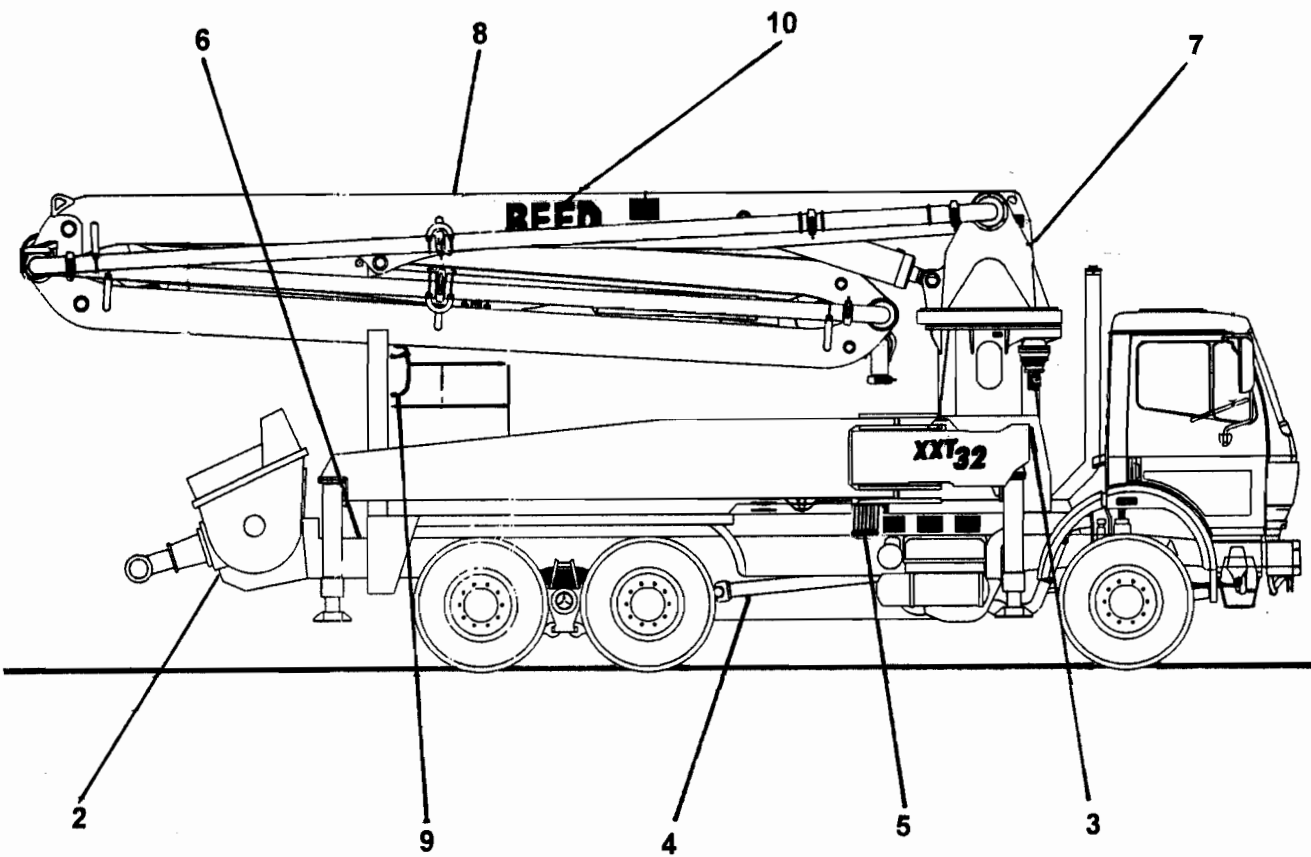

ITEM NO.	REED'S PARTS NO.	DESCRIPTION					QTY
		1	2	3	4	5	
-1	800519	Installation, XXT 32 Final					Ref
2	20-01	• Installation, Hopper (See Group 20, Figure 01 for DET)					1
3	30-01	• Installation, Tank (See Group 30, Figure 01 for DET)					1
4	40-01	• Installation, Power Train (Bef Jul 1999) (See Group 40, Figure 01 for DET)					1
	40-02	• Installation, Power Train (Aug 1999 ~ Mar 2000) (See Group 40, Figure 01 for DET)					1
	40-03	• Installation, Power Train (Apr 200 ~ Feb 2001) (See Group 40, Figure 01 for DET)					1
	40-04	• Installation, Power Train (Aft Mar 2001) (See Group 40, Figure 01 for DET)					1
5	50-01	• Installation, Control (Bef May 2000) (See Group 50, Figure 01 for DET)					1
	50-02	• Installation, Control (Aft Jun 2000) (See Group 50, Figure 01 for DET)					1
6	60-01	• Installation, Pumping Train (See Group 60, Figure 01 for DET)					1
7	70-01	• Installation, Frame and Support (See Group 70, Figure 01 for DET)					1
8	80-01	• Installation, Optional (See Group 80, Figure 01 for DET)					1
9	90-01	• Installation, Boom (See Group 90, Figure 01 for DET)					1
10	10-02	• Assembly, Decal (See Group 10, Figure 02 for DET)					1

DASH (-) ITEM NOT ILLUSTRATED

REED

DECAL ASSEMBLY

XXT 32
PARTS
GROUP 10
FIGURE 02
PAGE 01

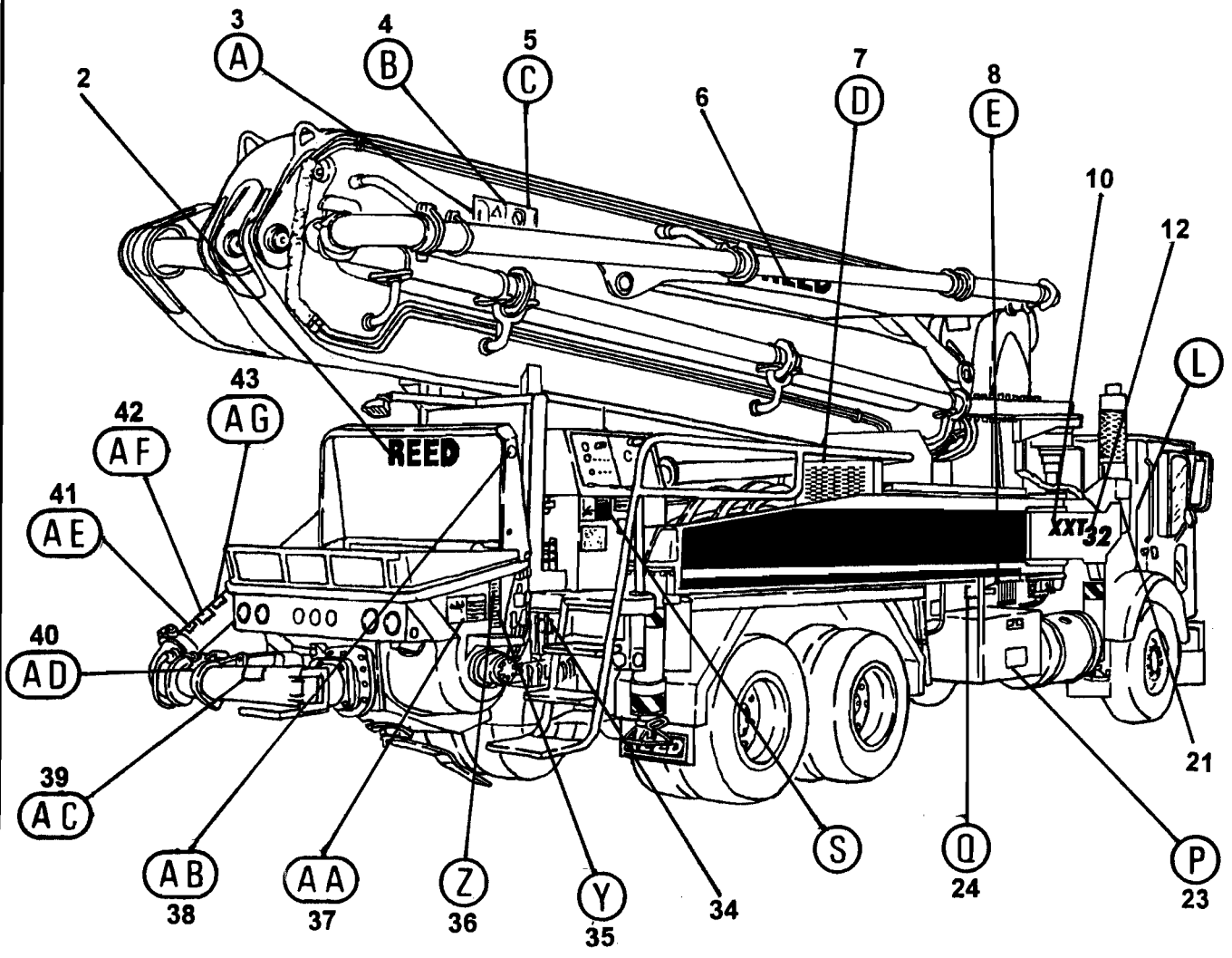
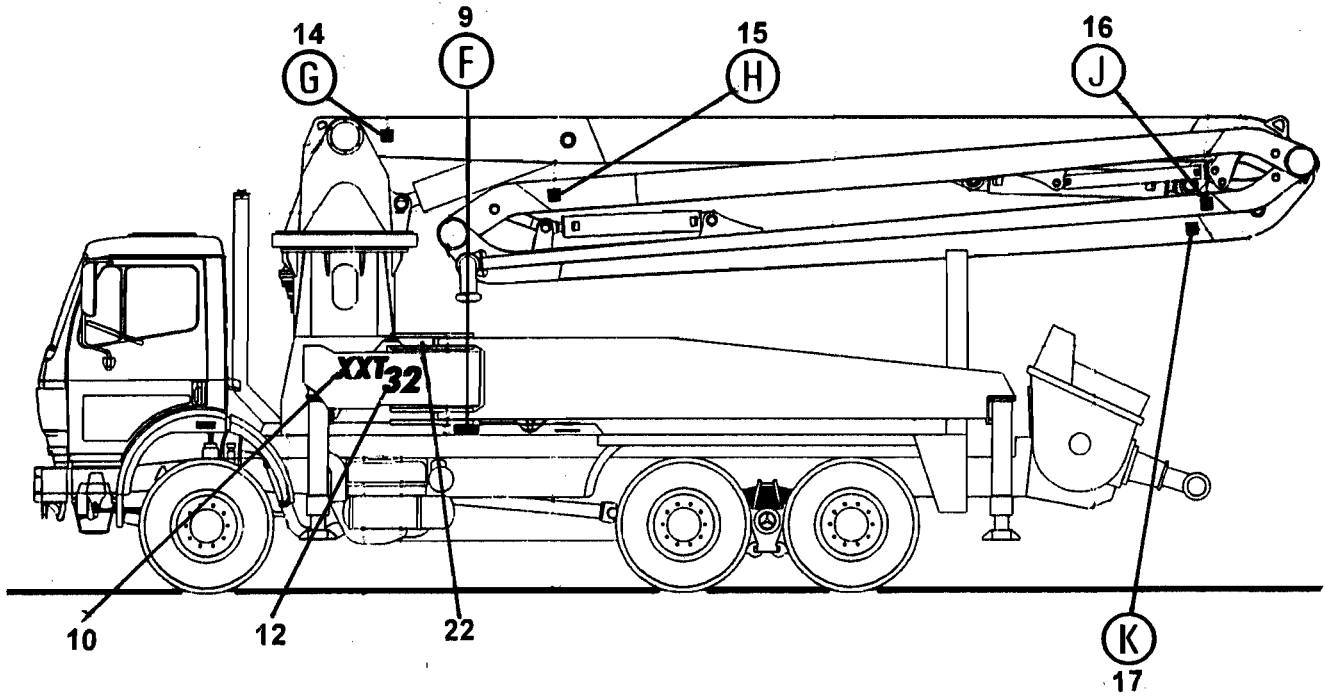

REVISION:

ITEM NO.	REED'S PARTS NO.	DESCRIPTION					QTY
		1	2	3	4	5	
-1	10-02	Assembly, Decal (See Group 10, Figure 01 for NHA)					Ref
2	800442	• Decal, REED , 6 Inch Black					1
3	C-4V107	• Plate, Danger Of Falling Object					1
4	C-4V106	• Plate, Never Use As Crane					1
5	C-4V105	• Plate, Death Hazard					1
6	801069	• Decal, REED , 12 Inch White					2
7	C-4V120	• Plate, Hydraulic Distributor					1
8	C-9V111	• Decal, Right Side Stabilizers					1
9	C-9V112	• Decal, Left Side Stabilizers					1
10	801068	• Decal, XXT , 5 Inch White					2
-11		• Decal, XXT , 5 Inch Optional Color					2
12	801070	• Decal, 32 , 8 Inch White					2
-13		• Decal, 32 , 8 Inch Optional Color					2
14	C-4V113	• Decal, A Letter Adhesive					1
15	C-4V115	• Decal, C Letter Adhesive					1
16	C-4V116	• Decal, D Letter Adhesive					1
17	C-4V114	• Decal, B Letter Adhesive					1
-18	800766	• Kit, XXT 32 Decal					1
19	800051	•• Nameplate, PTO					1
20	800059	•• Plate, PTO Operation					1
21	800034	•• Decal, Oil Level					2
22	800033	•• Decal, Water					1
23	800915	•• Decal, Danger, Stay Clear					1
24	800919	•• Decal, Warning, Stand Clear of Outriggers when activating					4
-25	800920	•• Decal, Warning, Clear Area Before Activating Outriggers					2
26	800439	•• Decal, Control Box Panel					1
27	801113	•• Decal, Gauge					1
28		•• Decal, A B					1
29	800926	•• Decal, Warning, Do Not Operate This Machine without					1
30	800929	•• Decal, Warning					1
31	800925	•• Decal, Warning, Do Not Operate This Machine without					1
32	800930	•• Decal, ACPA Hand Signals					1
33	800913	•• Decal, Danger, Electrocution Hazard					1
34	800875	•• Nameplate, Agitator / Water					1
35	800918	•• Decal, Warning, Do Not Stand on Hopper Grate					2
36	800917	•• Decal, Warning, Keep Hand Out of Hopper and Valve					2
37	800924	•• Decal, Warning, This Machine is Remote Controlled and					1
38	800931	•• Decal, ACPA Member					1
39	800922	•• Decal, Warning, Before Opening a Blocked Pipeline,					1
40	800923	•• Decal, Warning, Use Retaining Pins in all Delivery					1
41	800928	•• Decal, Warning, Total Weight of all Hanging Hoses,					1
42	800927	•• Decal, Warning, Do Not Use the Boom as a Crane					1
43	800921	•• Decal, Warning, Do Not Operate at Pressures Exceeding					1
-44	800914	•• Decal, Danger, Electrocution Hazard					1
-45	800916	•• Decal, Warning, Keep Hand Out of Water Box					1
46	75009	•• Nameplate, REED , Serial No.					1

DASH (-) ITEM NOT ILLUSTRATED

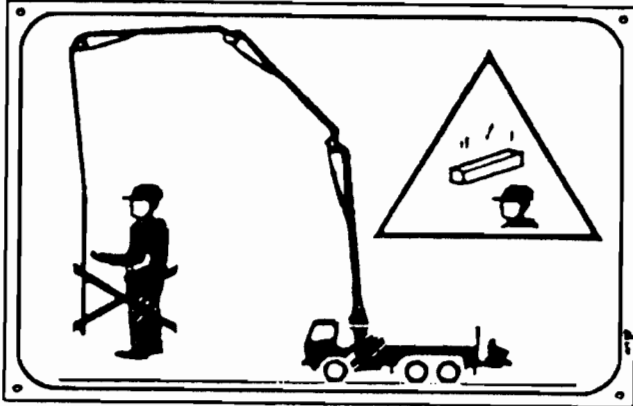

(A)

3

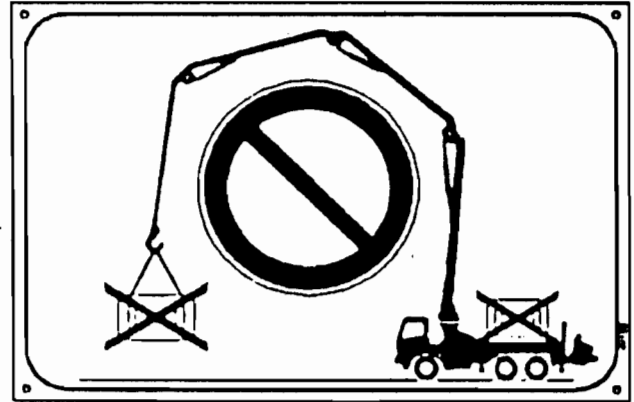

(B)

4

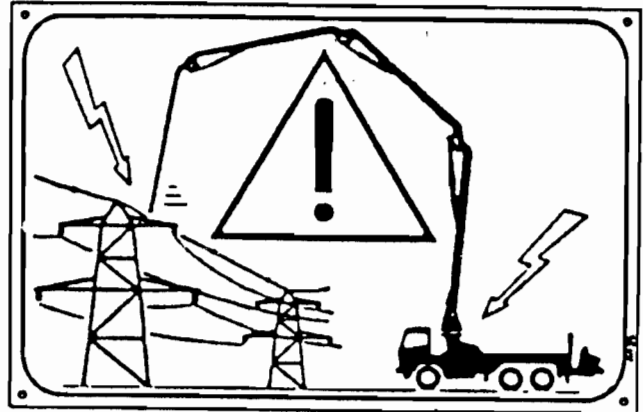

(C)

5

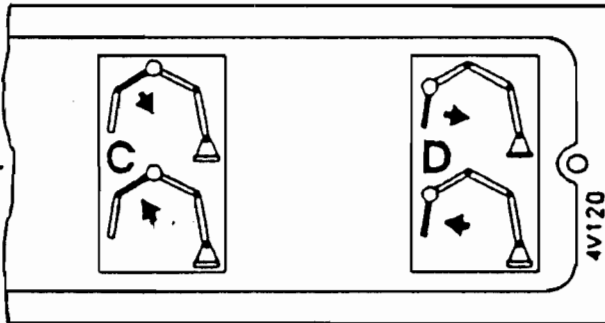

(D)

7

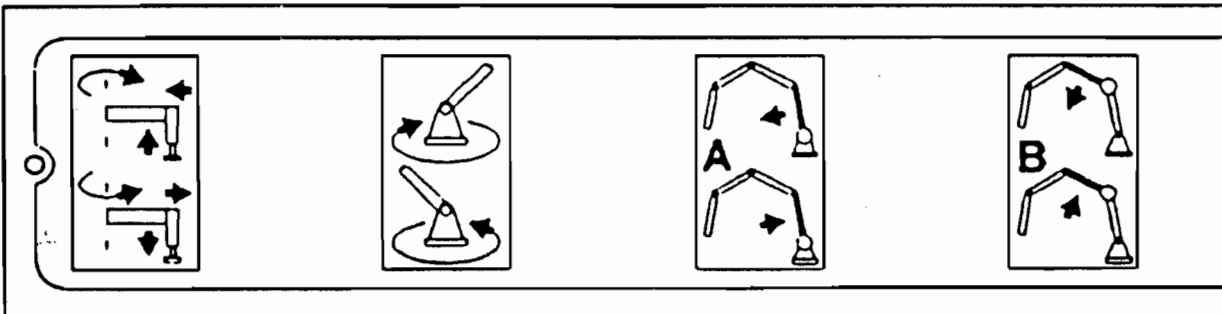

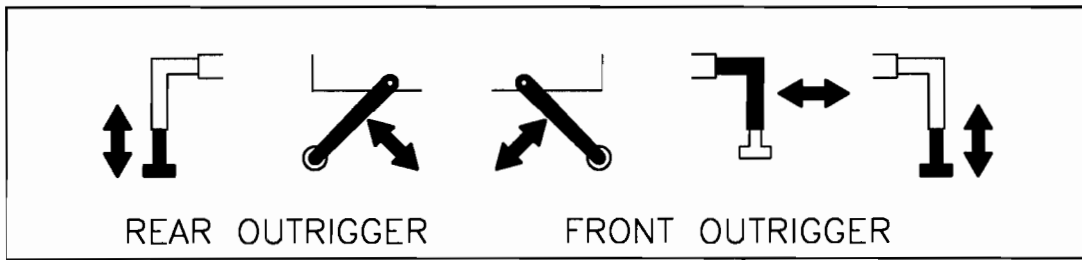

(E)

8

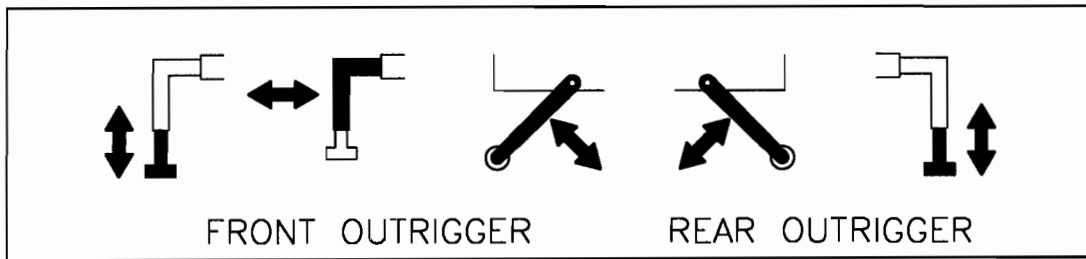

9

(F)

B

17

(K)

A

14

(G)

D

16

(J)

C

15

(H)

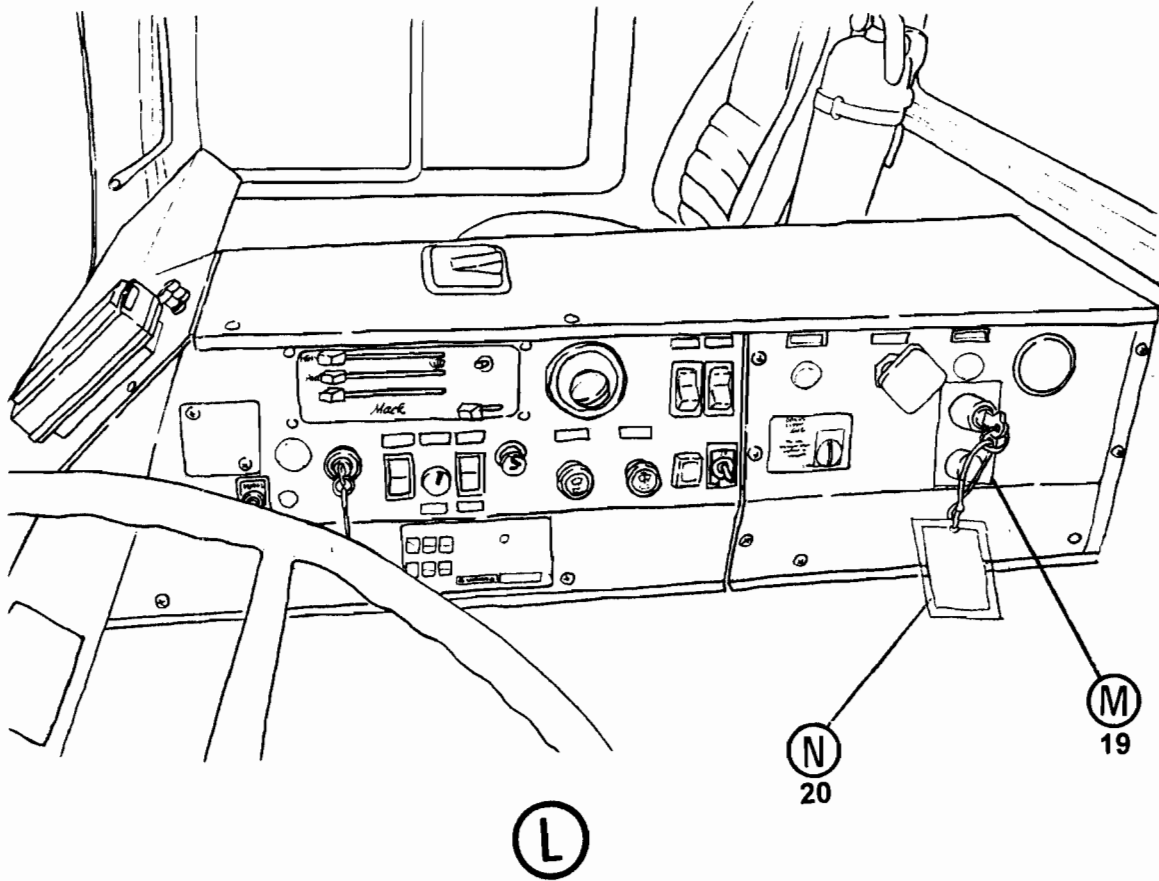

TO OPERATE PUMP AND BOOM

1. POSITION TRUCK AND SET PARKING BRAKE.
2. DEPRESS CLUTCH AND SHIFT TO 7TH GEAR HIGH.
3. TURN PTO ON.
4. RELEASE CLUTCH TO ENGAGE PUMPS.
5. SET THROTTLE AT 1600 RPM MAXIMUM.

TO RETURN TO DRIVING MODE

1. RETURN THROTTLE TO IDLE.
2. DEPRESS CLUTCH AND TURN PTO OFF.
3. SHIFT TO NUETRAL AND RELEASE CLUTCH.

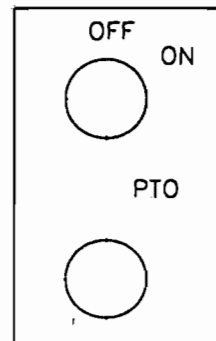

19

20

(N)

(M)



⚠ DANGER

Stay clear.
Contact will result in
death or serious injury
if the unit becomes
electrically charged.

800915

23

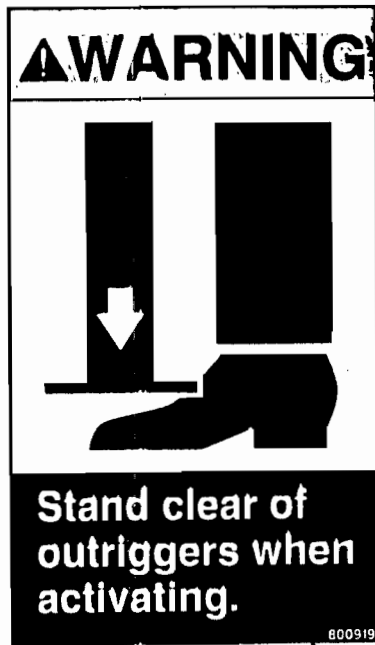

25

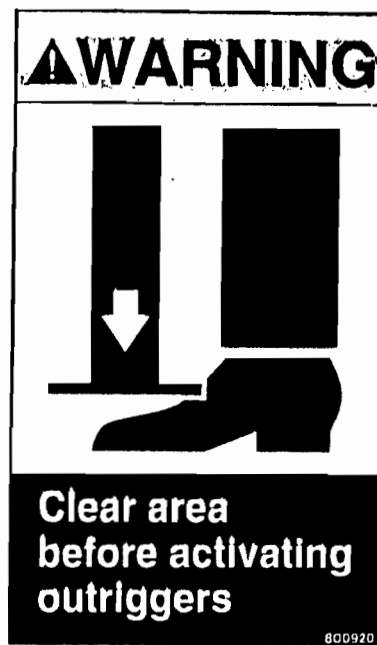

24



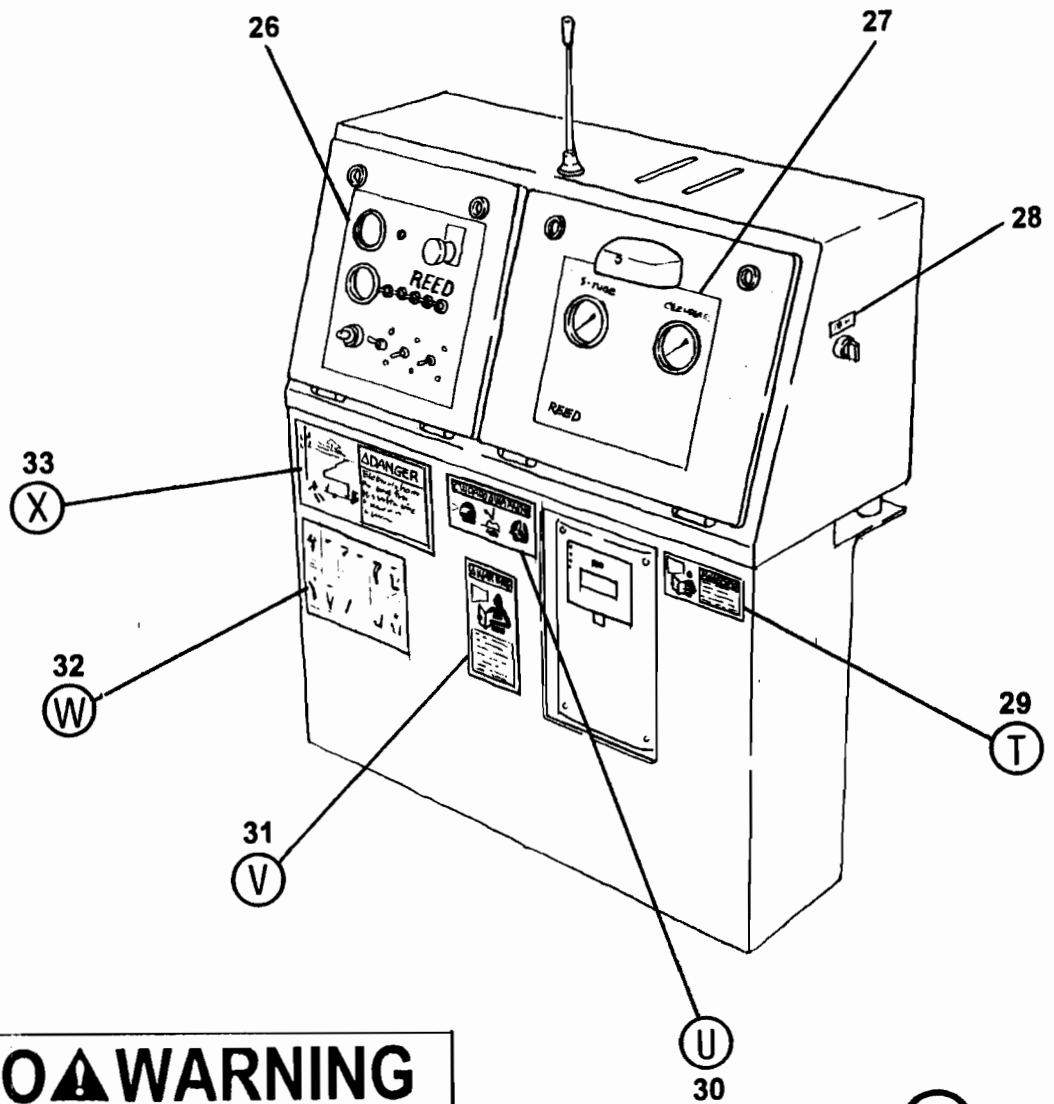

CUIDADO ⚠ WARNING

--	--	--

800929

U

30

T

⚠ WARNING

Do not operate this machine without training. Understand the warnings in safety manuals and on decals.

800920

⚠ WARNING



Do not operate this machine without training. Understand the warnings in safety manuals and on decals.

800925

31



32



1. BOOM UP



2. BOOM DOWN



3. BOOM LEFT



4. BOOM RIGHT



5. OPEN OR EXTEND BOOM



6. CLOSE OR RETRACT BOOM



7. STOP BOOM



8. START PUMP SPEED UP



9. SLOW PUMP DOWN



10. STOP PUMP



11. LITTLE BIT



12. ADD WATER 4-GALLONS



13. ALL DONE CLEAN UP

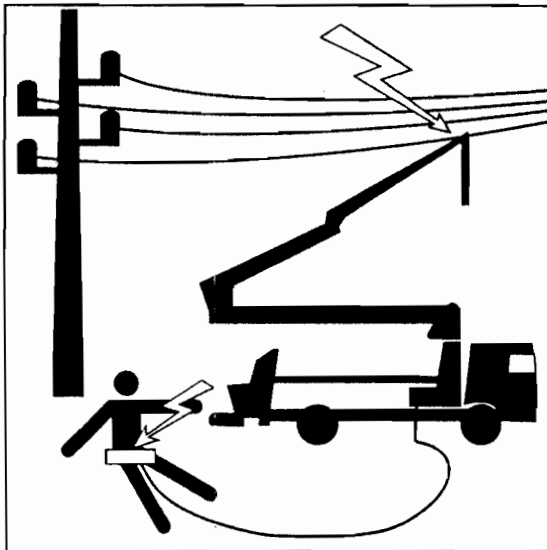

! DANGER

Electrocution hazard.
Stay back from
high voltage wires
at least 17 feet
(5 meters).

800913

(X)

33

! WARNING

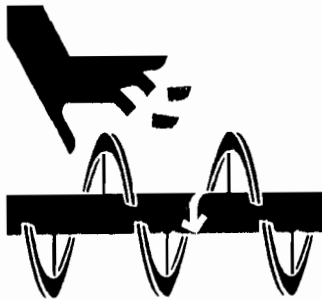

Keep hands out
of hopper and
valve assembly.
See operation
manual if access
is required.

800917

(Z)

36

! WARNING



Do not stand on
hopper grates.

800918

(Y)

35

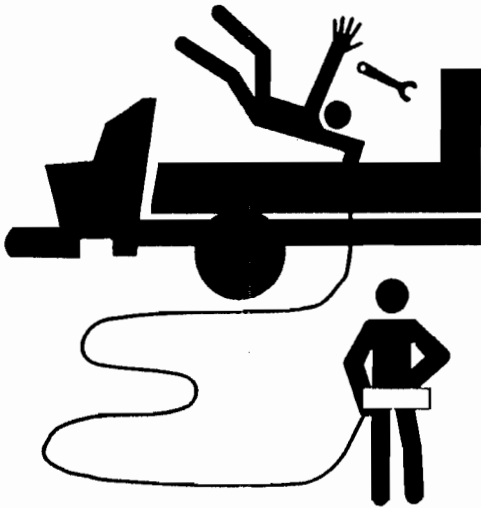

! WARNING

This machine is remote controlled and may start at any time. Stop engine before servicing unit.

800924

AA

37



! WARNING

Use retaining pins in all delivery system snap clamps.

800923

AD

40



38

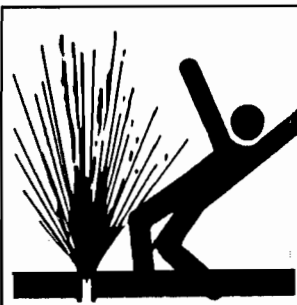

! WARNING

Before opening a blocked pipeline, relieve pressure by reversing pump. See manual.

800922

39

AC

AB

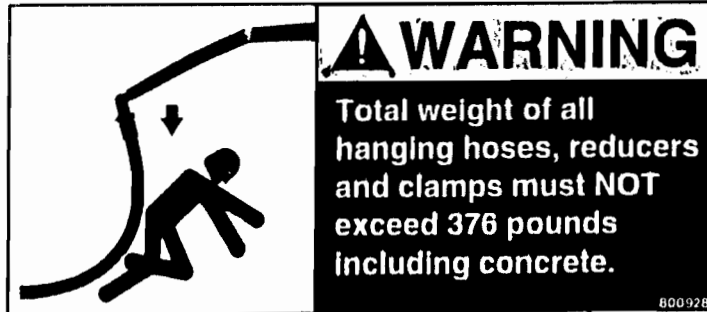

AE

41

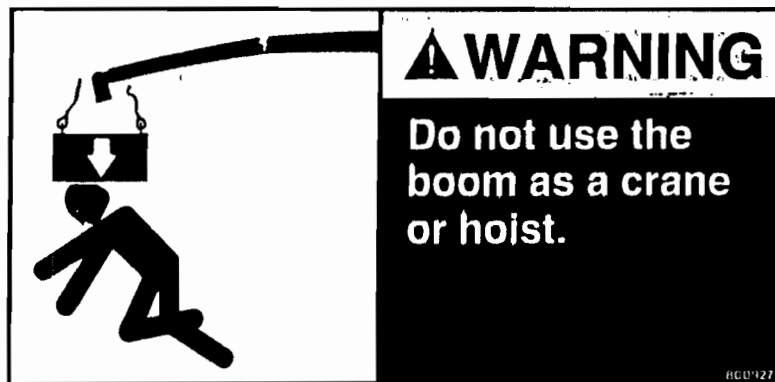

AF

42



AG

43

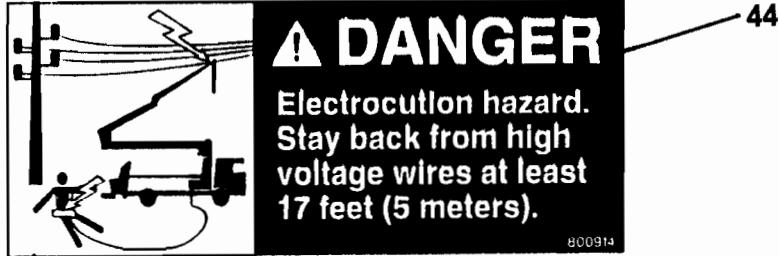

AH



AJ

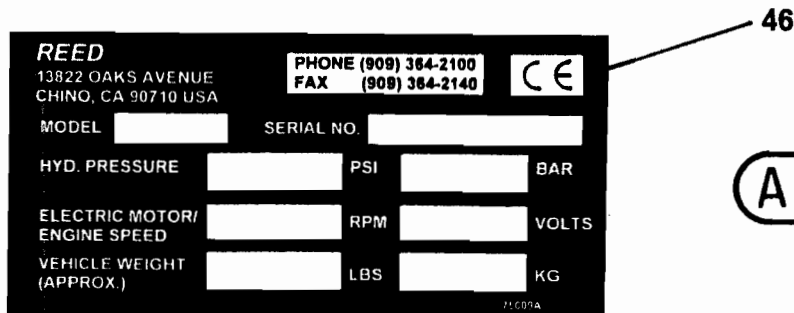

AK

ITEM NO.	REED'S PARTS NO.	DESCRIPTION					QTY
		1	2	3	4	5	
-1	10-02	Assembly, Decal (See Group 10, Figure 01 for NHA)					Ref
2	800442	• Decal, REED , 6 Inch Black					1
3	C-4V107	• Plate, Danger Of Falling Object					1
4	C-4V106	• Plate, Never Use As Crane					1
5	C-4V105	• Plate, Death Hazard					1
6	801069	• Decal, REED , 12 Inch White					2
7	C-4V120	• Plate, Hydraulic Distributor					1
8	C-9V111	• Decal, Right Side Stabilizers					1
9	C-9V112	• Decal, Left Side Stabilizers					1
10	801068	• Decal, XXT , 5 Inch White					2
-11		• Decal, XXT , 5 Inch Optional Color					2
12	801070	• Decal, 32 , 8 Inch White					2
-13		• Decal, 32 , 8 Inch Optional Color					2
14	C-4V113	• Decal, A Letter Adhesive					1
15	C-4V115	• Decal, C Letter Adhesive					1
16	C-4V116	• Decal, D Letter Adhesive					1
17	C-4V114	• Decal, B Letter Adhesive					1
-18	800766	• Kit, XXT 32 Decal					1
19	800051	•• Nameplate, PTO					1
20	800059	•• Plate, PTO Operation					1
21	800034	•• Decal, Oil Level					2
22	800033	•• Decal, Water					1
23	800915	•• Decal, Danger, Stay Clear					1
24	800919	•• Decal, Warning, Stand Clear of Outriggers when activating					4
-25	800920	•• Decal, Warning, Clear Area Before Activating Outriggers					2
26	800439	•• Decal, Control Box Panel					1
27	801113	•• Decal, Gauge					1
28		•• Decal, A B					1
29	800926	•• Decal, Warning, Do Not Operate This Machine without					1
30	800929	•• Decal, Warning					1
31	800925	•• Decal, Warning, Do Not Operate This Machine without					1
32	800930	•• Decal, ACPA Hand Signals					1
33	800913	•• Decal, Danger, Electrocutation Hazard					1
34	800875	•• Nameplate, Agitator / Water					1
35	800918	•• Decal, Warning, Do Not Stand on Hopper Grate					2
36	800917	•• Decal, Warning, Keep Hand Out of Hopper and Valve					2
37	800924	•• Decal, Warning, This Machine is Remote Controlled and					1
38	800931	•• Decal, ACPA Member					1
39	800922	•• Decal, Warning, Before Opening a Blocked Pipeline,					1
40	800923	•• Decal, Warning, Use Retaining Pins in all Delivery					1
41	800928	•• Decal, Warning, Total Weight of all Hanging Hoses,					1
42	800927	•• Decal, Warning, Do Not Use the Boom as a Crane					1
43	800921	•• Decal, Warning, Do Not Operate at Pressures Exceeding					1
-44	800914	•• Decal, Danger, Electrocutation Hazard					1
-45	800916	•• Decal, Warning, Keep Hand Out of Water Box					1
46	75009	•• Nameplate, REED , Serial No.					1

DASH (-) ITEM NOT ILLUSTRATED

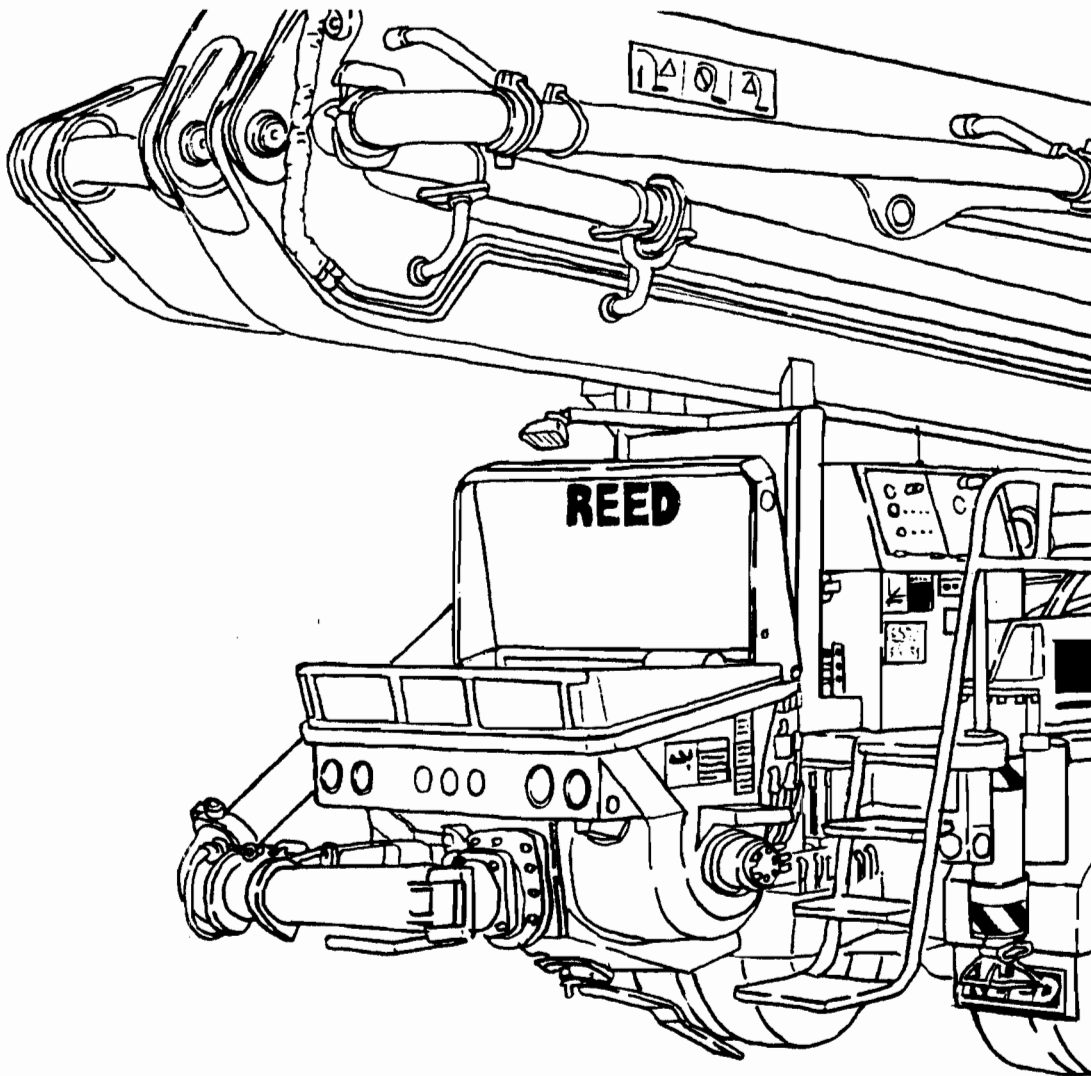

REED TRUCK MOUNTED CONCRETE BOOM PUMP MODEL XXT 32 ILLUSTRATED PARTS MANUAL GROUP 20 HOPPER INSTALLATION CONTAINS THE FOLLOWING FIGURES:

- | | |
|------------------|--------------------------------------|
| FIGURE 00 | TABLE OF CONTENTS |
| FIGURE 01 | HOPPER INSTALLATION |
| FIGURE 02 | LUBRICATION PUMP ASSEMBLY |
| FIGURE 03 | CENTRAL LUBRICATION SYSTEM |
| FIGURE 04 | HOPPER VIBRATION ASSEMBLY |
| FIGURE 05 | AGITATOR ASSEMBLY |
| FIGURE 06 | AGITATOR DRIVE MOTOR ASSEMBLY |
| FIGURE 07 | HOPPER OUTLET ASSEMBLY |

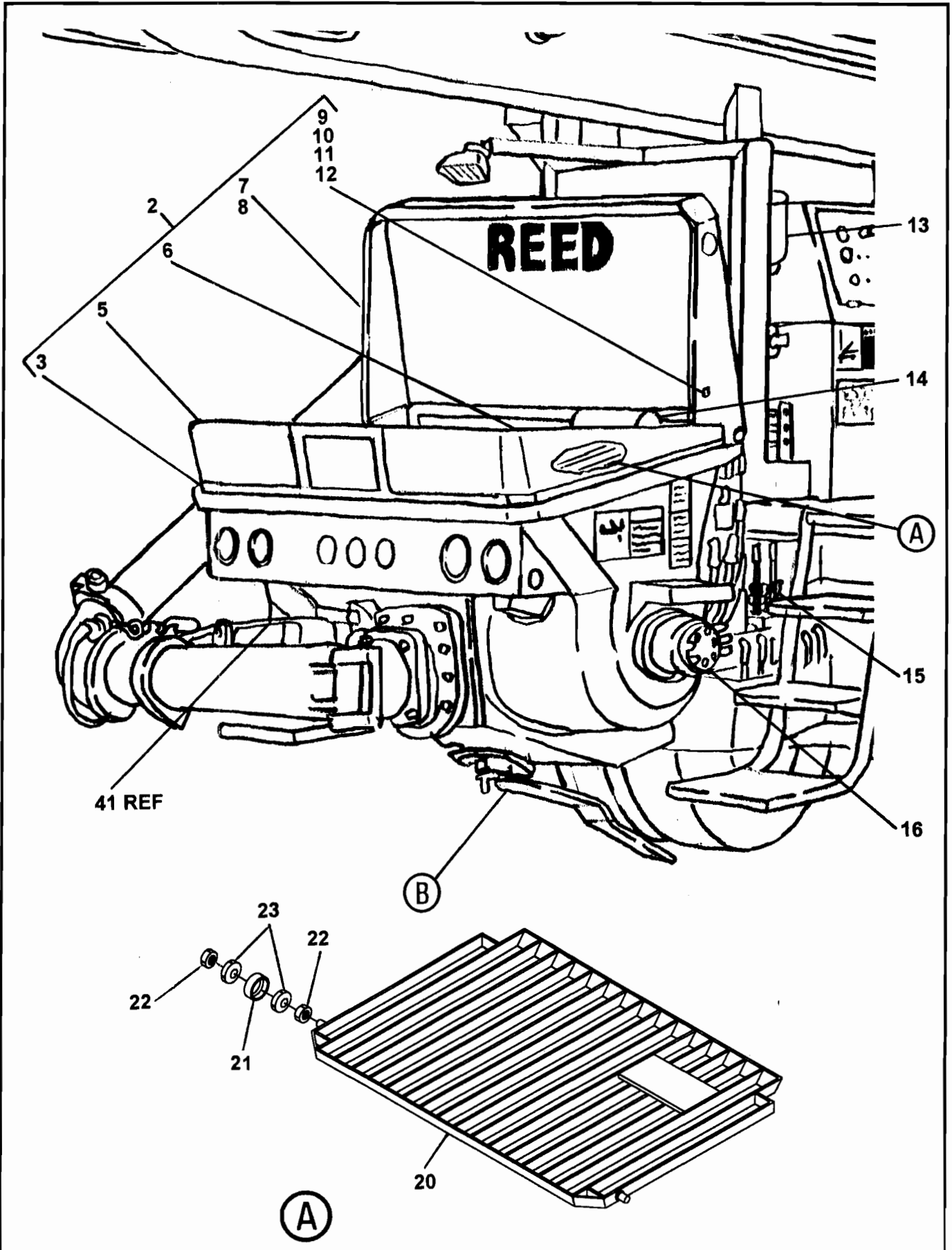

ITEM NO.	REED'S PARTS NO.	DESCRIPTION	QTY
-1	20-01	Installation, Hopper (See Group 10, Figure 01 for NHA)	Ref
2	800419	• Group, Splash Guard	1
3	800398	• • Bar, Splash Guard	1
-4	800402	• • Strip, Silicon 0.53	1
5	800399	• • Rubber Flap, Splash Guard	1
6	800416	• • Rubber, Splash Guard 10 FT	1
7	79056	• • Handle, Splash Guard	1
8	800395	• • Weldment, Splash Guard	1
9	800400	• • Pivot plate, Splash Guard	2
10	800401	• • Plunger, Spring	2
11	800417	• • Pin	1
12	800418	• • Lanyard	1
13	B-183000	• Assembly, Central Lubrication System (See Group 20, Figure 02 for DET)	1
14	71429	• Assembly, Hopper Vibration (See Group 20, Figure 04 for DET)	1
15	W-100124	• Assembly, Agitator/Wash Control Valve	1
-16	B-254120	• Assembly, Agitator (See Group 20, Figure 05 for DET)	1
-17	W-104067	• Buffer, Grid Rubber	4
-18	W-101559	• Washer (attaching parts)	4
19	W-101847	• Nut, Cap (attaching parts)	8
20	B-224035	• Grid	1
21	W101849	• Buffer, Rubber	2
22	W-101559	• Washer	4
23	B-223011	• Nut, Cap	4

DASH (-) ITEM NOT ILLUSTRATED

HOPPER INSTALLATION

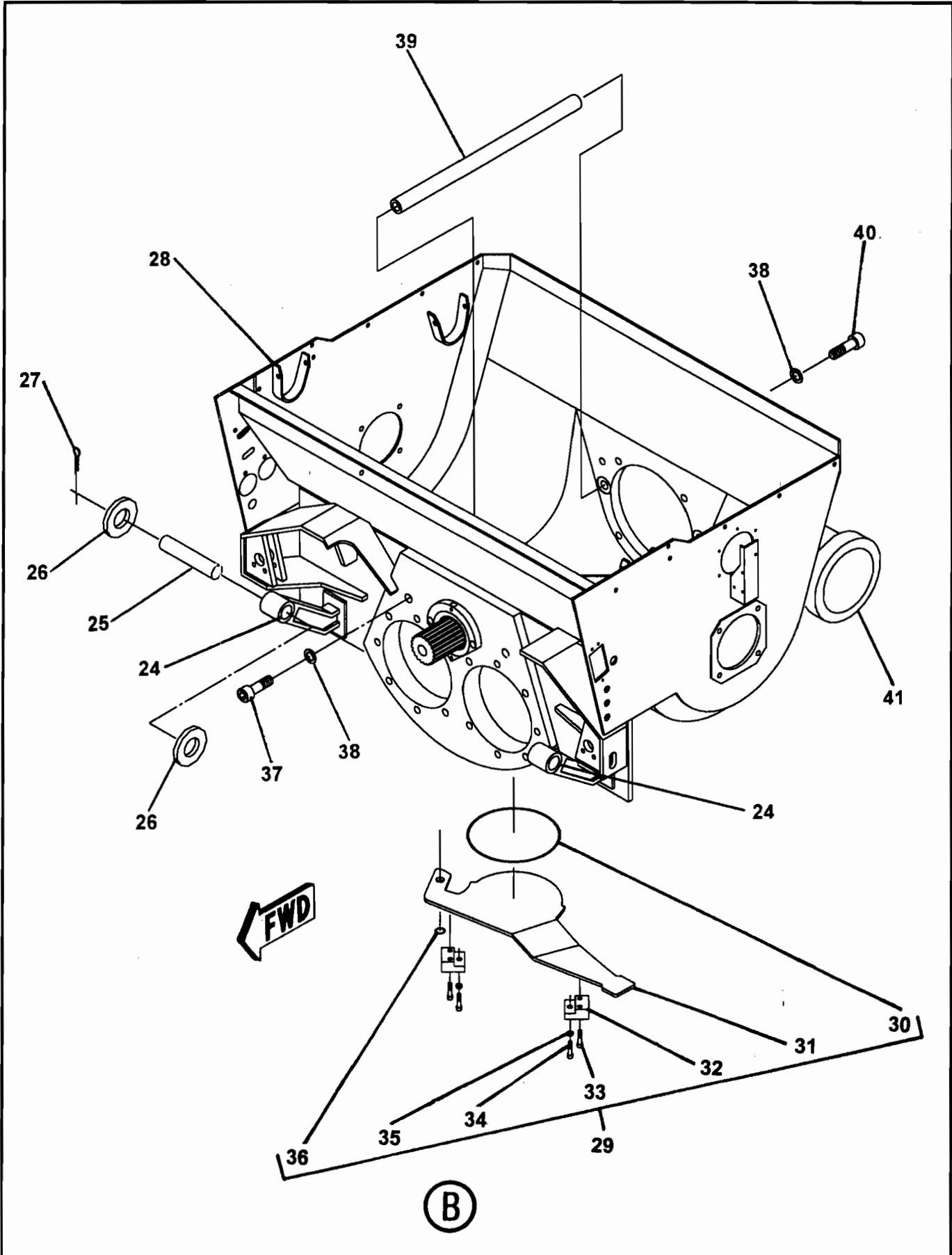

ITEM NO.	REED'S PARTS NO.	DESCRIPTION					QTY
		1	2	3	4	5	
24	W-102489	• Buffer, Rubber					2
25	W-100940	• Pin					2
26	W-103411	• Washer					4
27		• Pin, Cotter					4
28	B-173021	• Weldment, Hopper					1
29	B-173085	• Assembly, Cleaning Cover					1
30	W-102908	• • O-Ring, Round Cord					1
31	B-172130	• • Cover, Cleaning					1
32	B-172126	• • Block, Clamping					2
33	W-102855	• • Screw, M20 (attaching parts)					4
34	B-172218	• • Screw, M20 (attaching parts)					2
35	W-102891	• • Nut, Hex M20 (attaching parts)					2
36	W-102864	• • Ring, Lock					1
37	W-103074	• Screw, Hex					2
38	W-102331	• Washer					4
39	B-174075	• Rod, Tie					2
40	W-103073	• Screw, Hex M24					2
41	20-07	• Assembly, Hopper Outlet (See Group 20, Figure 07 for DET)					1

DASH (-) ITEM NOT ILLUSTRATED

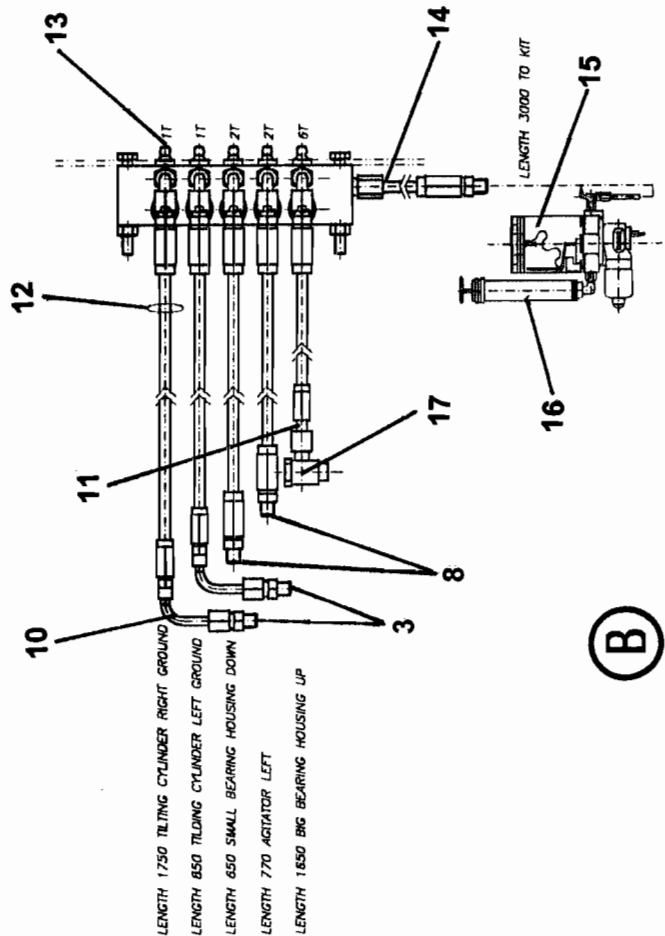
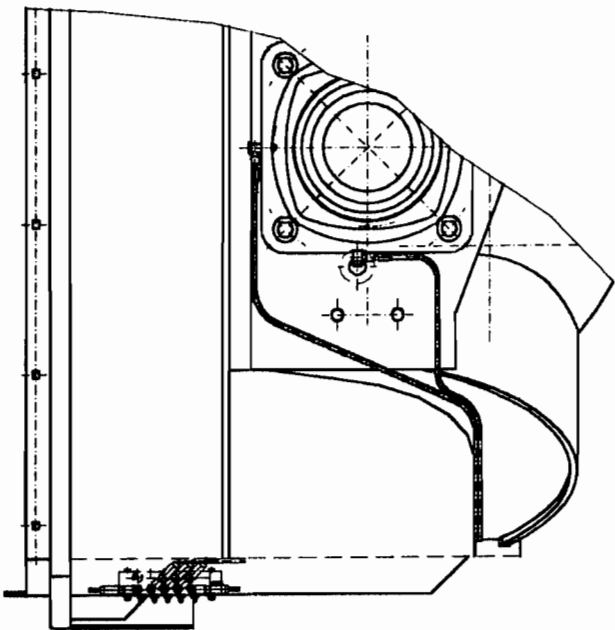
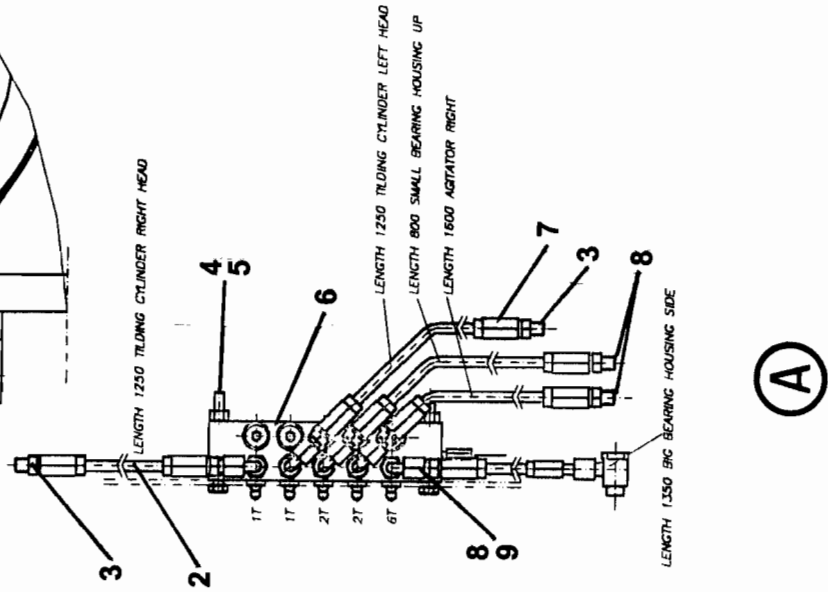
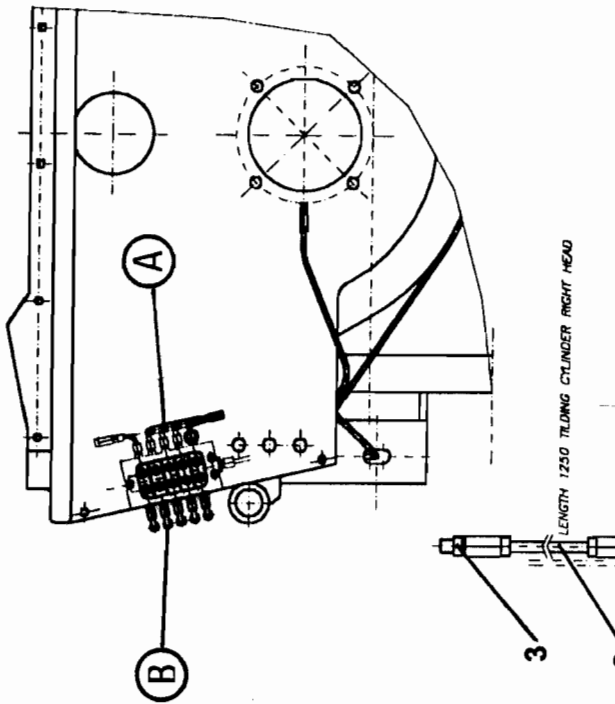



CENTRAL LUBRICATION SYSTEM

XXT 32
PARTS
GROUP 20
FIGURE 02
PAGE 02

ITEM NO.	REED'S PARTS NO.	DESCRIPTION					QTY
		1	2	3	4	5	
-1	B-183000	System, Central Lubrication (See Group 20, Figure 01 for NHA)					Ref
2	W-100255	• Pipe, Plastic					1
3	W-102603	• Coupling, Straight Male Stud					4
4	W-103512	• Screw, Hex					3
5	W-102131	• Nut, Lock					3
6	W-102602	• Distributor, Lubrication					1
7	W-100254	• Sleeve, Threaded					22
8	W-100548	• Coupling, Straight Male Stud					5
9	W-102664	• Elbow, Adjustable					10
10	W-100643	• Sleeve, Threaded					2
11	W-100253	• Piece, Hose Connection					20
12	W-103137	• Tie, Cable					30
13	W-100303	• Nipple, Grease					10
14	W-102665	• Coupling, Straight Male Stud					1
15	800065	• Assembly, Lubrication Pump (See Group 20, Figure 03 for DET)					1
16	78532	• Gun, Grease					1
17	W-102884	• Elbow, Throttle Free benjo					2

DASH (-) ITEM NOT ILLUSTRATED

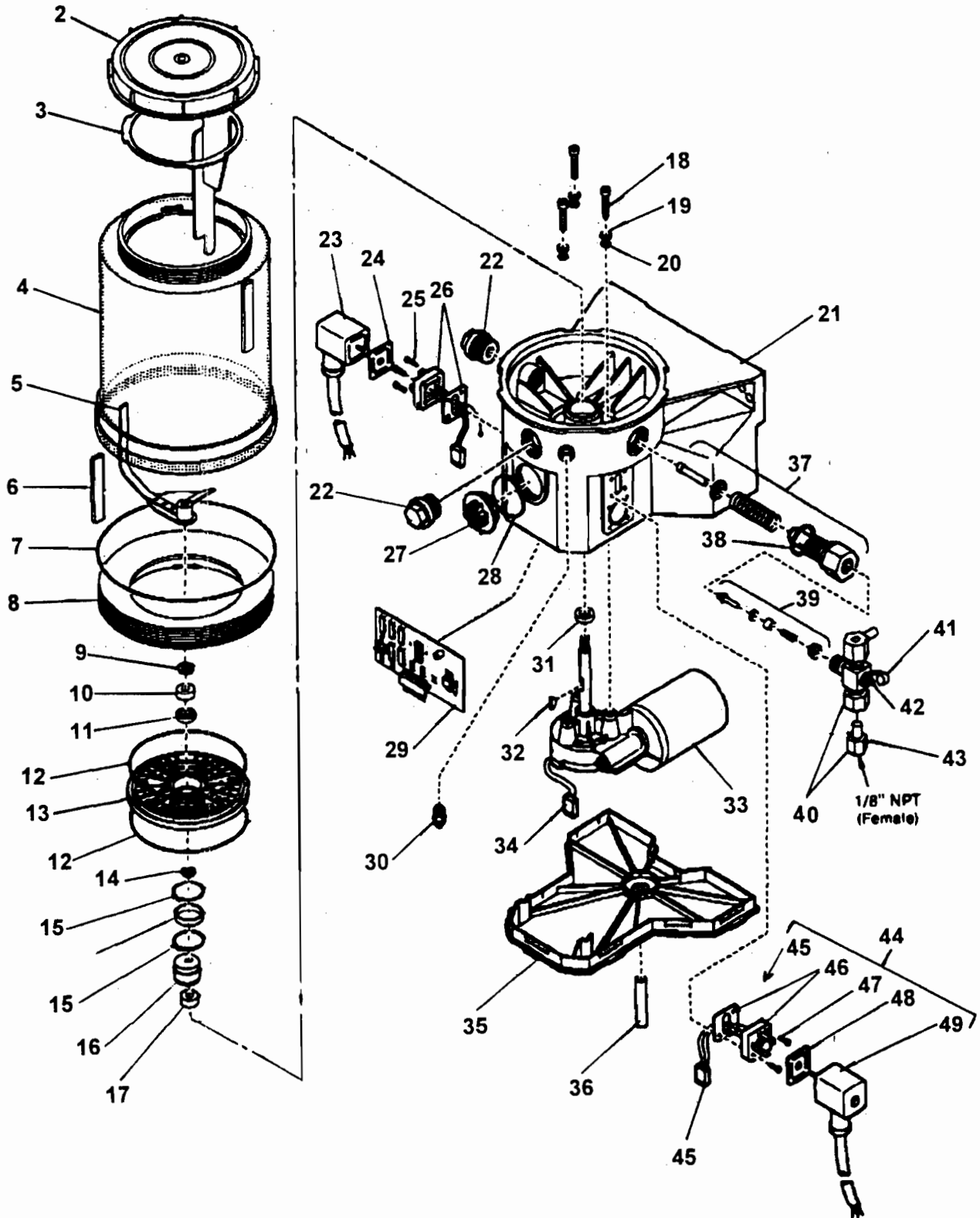

ITEM NO.	REED'S PARTS NO.	DESCRIPTION					QTY
		1	2	3	4	5	
-1	800065	Assembly, Lubrication Pump (See Group 20, Figure 02 for NHA)					Ref
2		• Lid					1
3		• Paddle, Fixed					1
4		• Reservoir					1
5		• Paddle, Stirring					1
6		• Hose					1
7		• O-Ring					1
8		• Adapter					1
9		• Washer					1
10		• Ring, Bearing					2
11		• Bearing					1
12		• O-Ring					2
13		• Plate, Intermediate					1
14		• Shim					1
15		• Ring, Snap					2
16		• Ring, Inner					1
17		• Cam, Eccentric					1
18		• Screw					3
19		• Washer					3
20		• O-Ring					3
21		• Housing, Pump					1
22		• Plug, Closure					2
23		• Socket with Cord					1
24		• Packing, Flat					1
25		• Screw					4
26		• Plug					1
27		• Plug, Sealing					1
28		• O-Ring					1
29		• Board, Printed Circuit					1
30		• Fitting, Grease					1
31		• Seal, Radial					1
32		• Key, Wood Ruff					1
33		• Motor, 12 VDC					1
34		• Plug, Motor					1
35		• Cover, Housing					1

DASH (-) ITEM NOT ILLUSTRATED

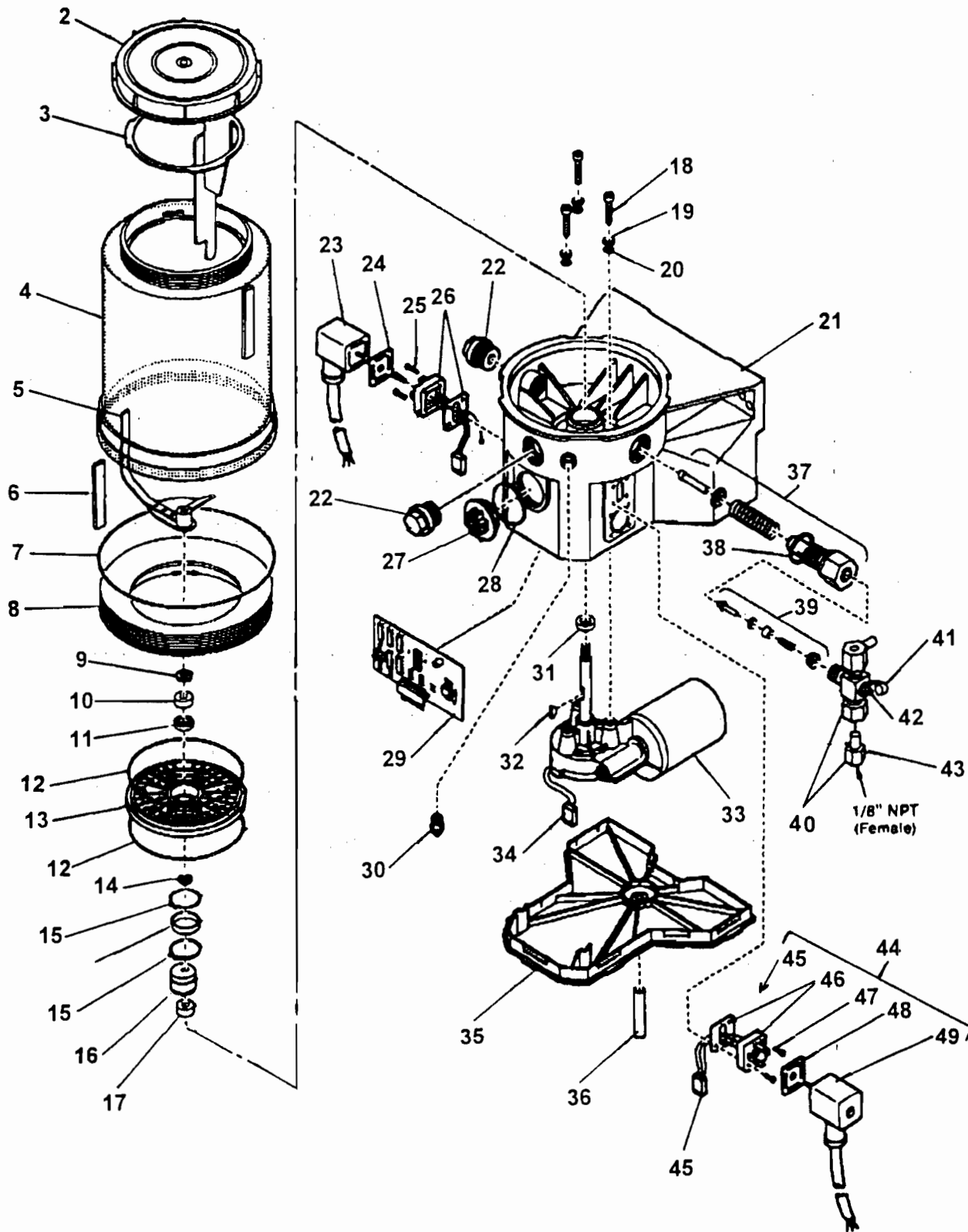



LUBRICATION PUMP ASSEMBLY

XXT 32
PARTS
GROUP 20
FIGURE 03
PAGE 04

ITEM NO.	REED'S PARTS NO.	DESCRIPTION					QTY
		1	2	3	4	5	
36		• Hose					1
37		• Element, Pump					1
38		• Gasket					1
39		• Valve, Check					1
40		• Assembly, Pressure Release					1
41		• Cap, Grease					1
42		• Fitting, Grease					1
43		• Adapter for Relief					1
44		• Assembly, Optional Pressure Relief Valve					1
45		• • Cord, Optional Power					1
46		• • Plug, Optional					1
47		• • Screw, Optional					4
48		• • Packing, Optional Flat					1
49		• • Socket, Optional					1

DASH (-) ITEM NOT ILLUSTRATED

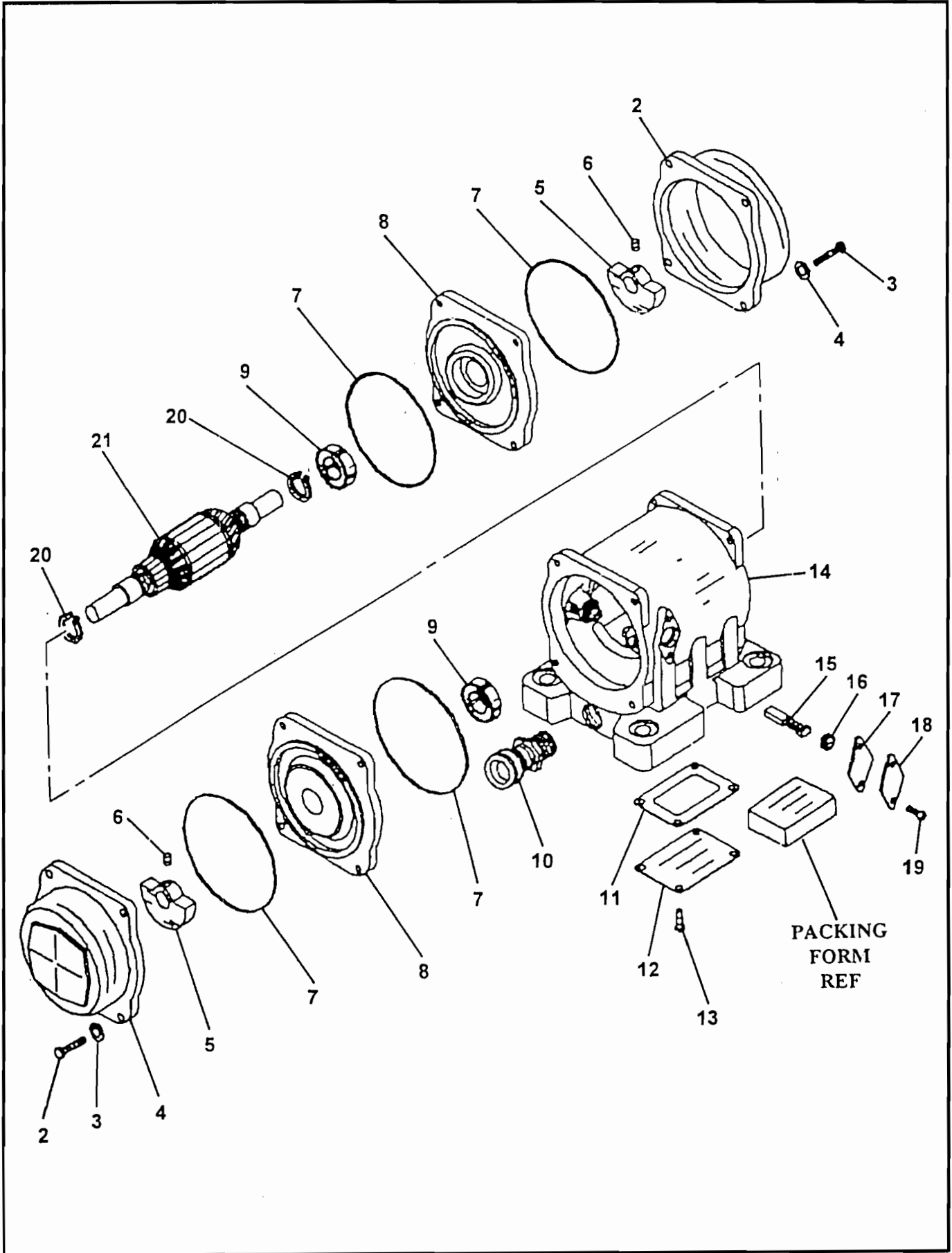

ITEM NO.	REED'S PARTS NO.	DESCRIPTION					QTY
		1	2	3	4	5	
-1	71429	Assembly, Hopper Vibrator (See Group 20, Figure 01 for NHA)					Ref
2		• Cap, End					2
3		• Bolt (attaching parts)					8
4		• Washer, Lock (attaching parts)					8
5		• Weight					2
6		• Screw, Set (attaching parts)					2
7		• O-Ring					4
8		• Bell, End					2
9		• Bearing					2
10		• Holder, Cord					1
11		• Gasket					1
12		• Cover, Box					1
13		• Screw (attaching parts)					4
14		• Sub-Assembly, Housing					1
15		• Brush					1
16		• Cap, Brush					2
17		• Gasket					2
18		• Cover, Brush					2
19		• Screw (attaching parts)					4
20		• Ring, Snap					2
21		• Assembly, Armature					1

DASH (-) ITEM NOT ILLUSTRATED

AGITATOR ASSEMBLY

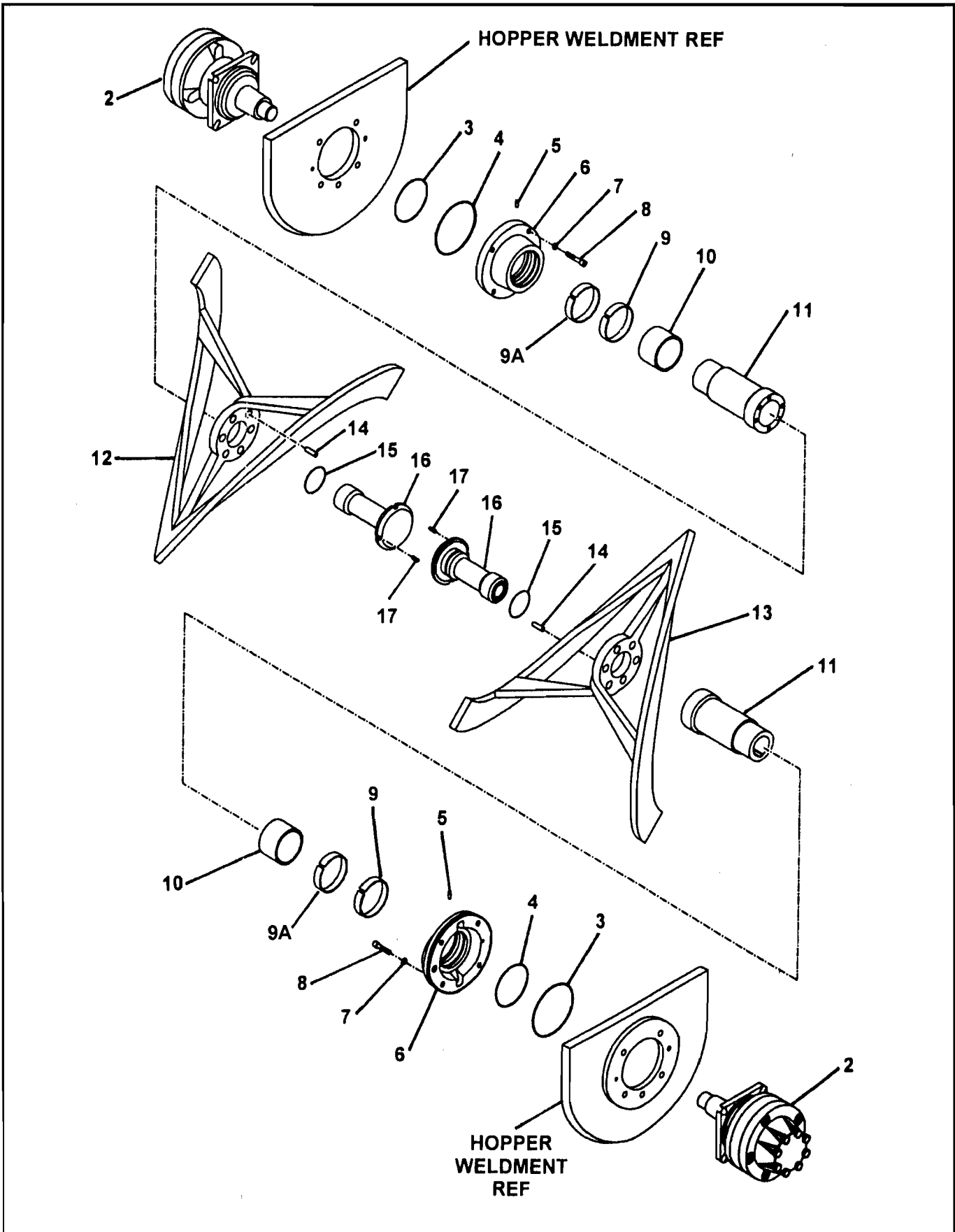

ITEM NO.	REED'S PARTS NO.	DESCRIPTION					QTY
		1	2	3	4	5	
-1	B-254120	Assembly, Agitator (See Group 20, Figure 01 for NHA)					Ref
2	W-101240	• Assembly, Agitator Drive Motor (See Group 20, Figure 08 for DET)					1
3	W-103064	• O-Ring					2
4	W-103063	• O-Ring					2
5	W-1004909	• Screw, M5 Set					2
6	B-254101	• Assembly, Flange					2
7	W-102962	• Washer					8
8	W-103062	• Screw, M12 Hex					8
9	W-102544	• Ring, Groove-Outer					2
9A	B-253029	• Ring, Groove-Inner					2
10	B-254104	• Sleeve, Wear					2
11	B-254102	• Shaft					2
12	B-254105	• Agitator, Left					1
13	B-254106	• Agitator, Right					1
14	W-103065	• Pin 10m					12
15	W-103249	• O-Ring					2
16	B-254103	• Nut					2
17	W-103106	• Sleeve, Clamping					4

DASH (-) ITEM NOT ILLUSTRATED



AGITATOR DRIVE MOTOR ASSEMBLY

XXT 32
PARTS
GROUP 20
FIGURE 06
PAGE 01

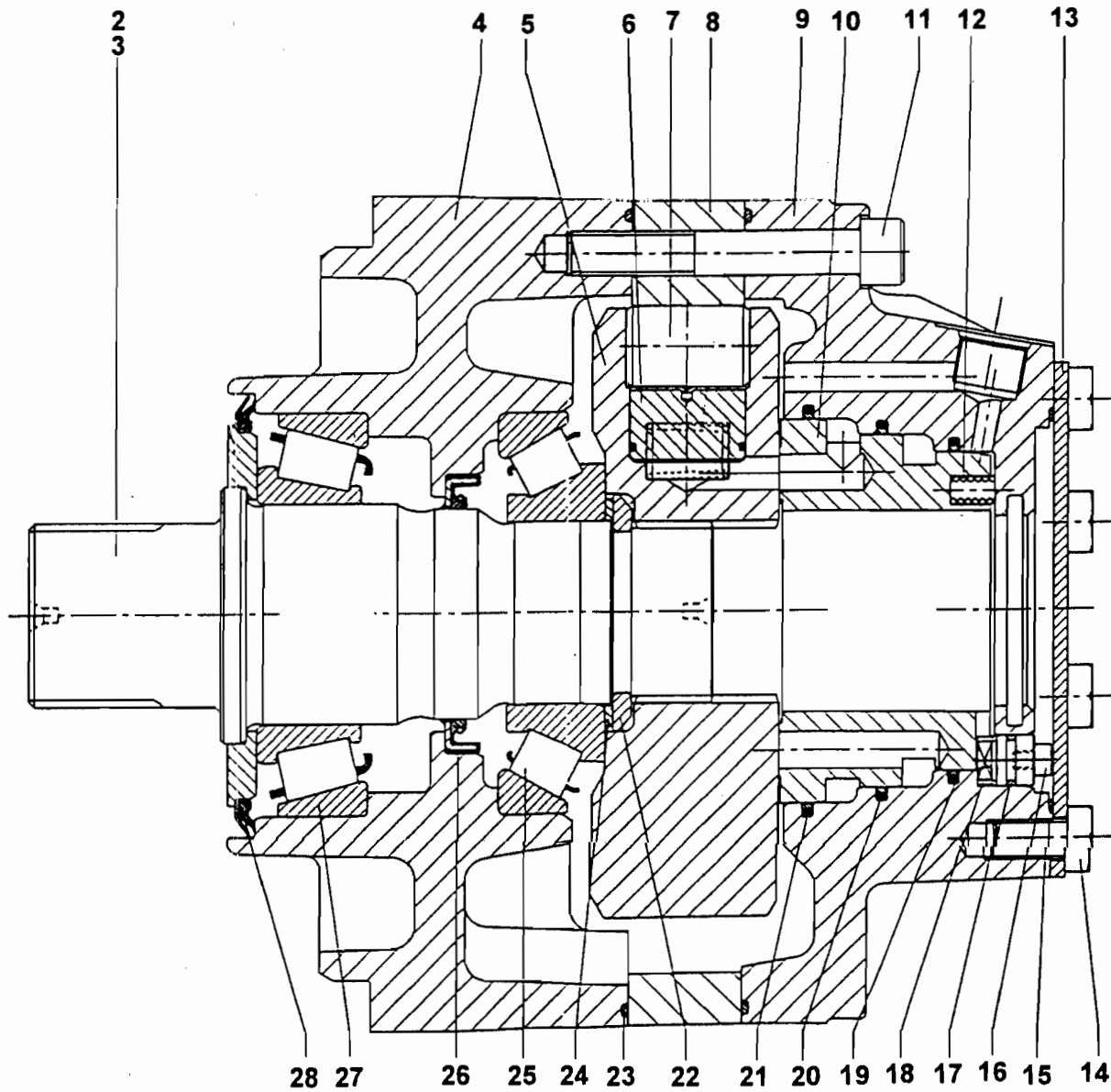

ITEM NO.	REED'S PARTS NO.	DESCRIPTION					QTY
		1	2	3	4	5	
-1	W-101240	Assembly, Agitator Drive Motor (See Group 20, Figure 05 for NHA)					Ref
2		• Assembly, Auger Drive Motor					1
3		• Shaft					1
4		• Case, Front					1
5		• Block, Cylinder					1
6		• Piston					8
7		• Roller					8
8		• Cam					1
9		• Case, Rear					1
10		• Ring, Distributor					1
11		• Screw, Cap M12					12
12		• Spring					6
13		• Plate, Cover					1
14		• Screw, Hex M10					8
15		• O-Ring					1
16		• Screw, Cap M5					1
17		• O-Ring					1
18		• Pin, Stop					1
19		• Seal, Rod					1
20		• Seal, Rod					1
21		• Seal, Rod					1
22		• Ring, Split					1
23		• O-Ring					2
24		• Washer					1
25		• Bearing					1
26		• Seal, Shaft					1
27		• Bearing					1
28		• Seal, Face					1

DASH (-) ITEM NOT ILLUSTRATED

CONCRETE DECK PIPE LINE ASSEMBLY
(SEE GROUP 90, FIGURE 10 FOR REF)

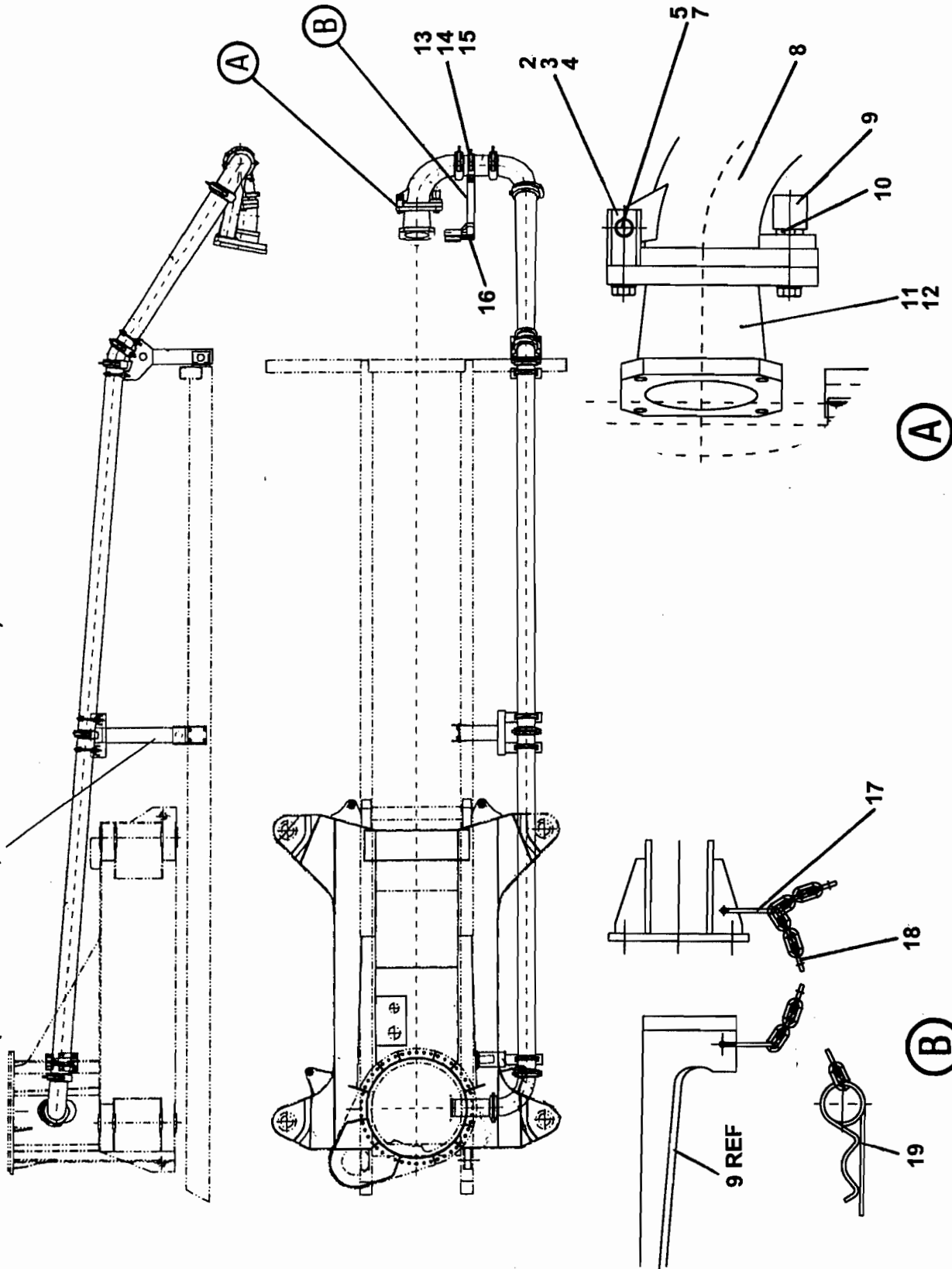

ITEM NO.	REED'S PARTS NO.	DESCRIPTION					QTY
		1	2	3	4	5	
-1	20-07	Assembly, Hopper Outlet (See Group 20, Figure 01 for NHA)					Ref
2	B-194049	• Hinge					2
3	W-102848	• Screw, M24 Hex Head					3
4	W-102331	• Washer					3
5	W-100694	• Ring, Snap					2
-6	B-194065	• Sub- Assembly, Hopper Outlet					1
7	B-194050	• • Bolt					1
8	B-191015	• • Elbow, Reducer					1
9	B-194046	• • Wedge, Locking					1
10	B-194045	• • Bolt, Locking					1
11	B-191010	• • Reducer					1
12	W-104025	• • O-Ring, Hopper Elbow					1
13	W-101779	• • Coupling, 6 Inch Clamp					3
14	W-100690	• • Elbow, 6 Inch					1
15	W-101545	• • O-Ring					3
16	B-194053	• • Coupling, Delivery Line Snap					1
17	W-103731	• S-Hook					2
18	W-103732	• Chain					1
19	W-103733	• Pin, Spring					1

DASH (-) ITEM NOT ILLUSTRATED

REED

**MODEL XXT 32 TRUCK MOUNTED
CONCRETE BOOM PUMP
ILLUSTRATED PARTS MANUAL**

**XXT 32
PARTS
GROUP 20
FIGURE 08
PAGE 01**

THIS PAGE INTENTIONALLY LEFT BLANK.

REED TRUCK MOUNTED CONCRETE BOOM PUMP MODEL **XXT 32** ILLUSTRATED PARTS MANUAL GROUP 30 HYDRAULIC TANK INSTALLATION CONTAINS THE FOLLOWING FIGURES:

- FIGURE 00** TABLE OF CONTENTS
- FIGURE 01** TANK INSTALLATION
- FIGURE 02** WATER SYSTEM GROUP
- FIGURE 03** WASH WATER PUMP ASSEMBLY
- FIGURE 04** WATER PUMP MOTOR ASSEMBLY

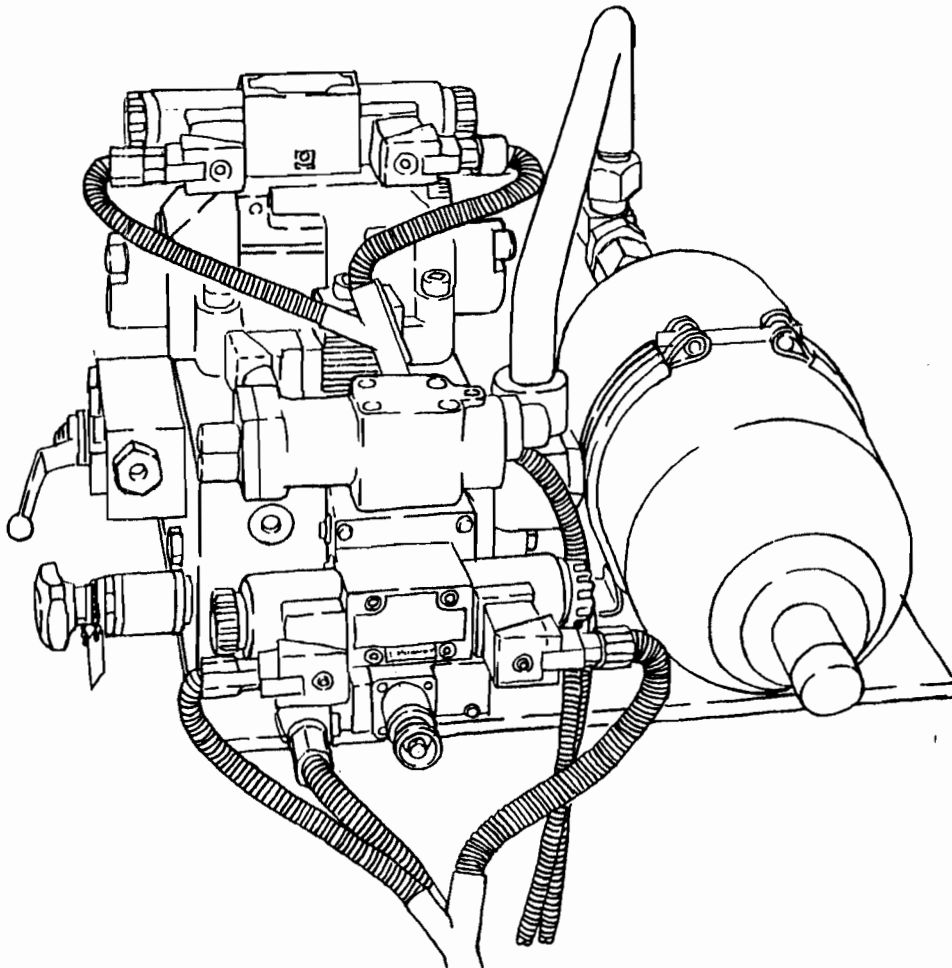

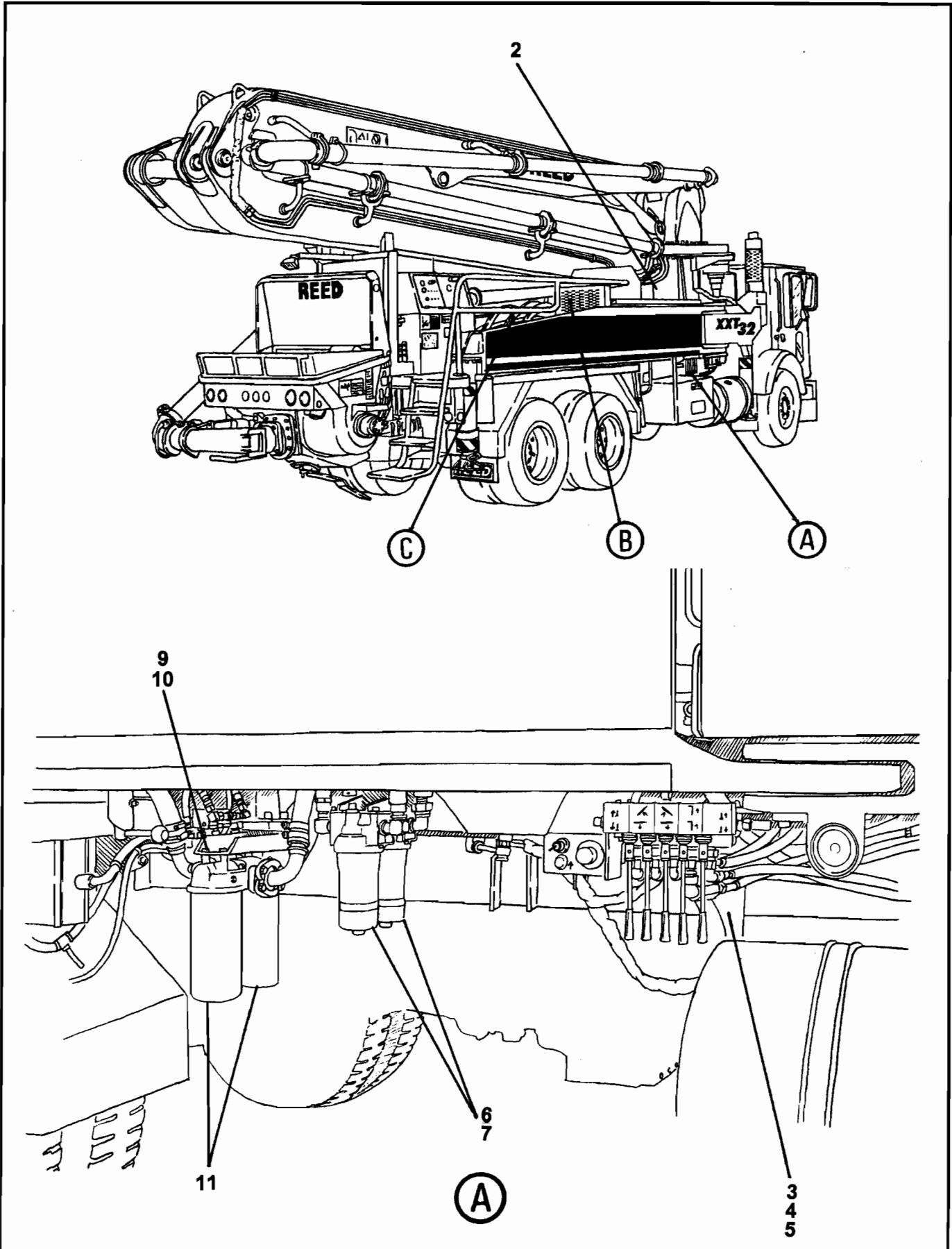

ITEM NO.	REED'S PARTS NO.	DESCRIPTION					QTY
		1	2	3	4	5	
-1	30-01	Installation, Tank (See Group 10, Figure 01 for NHA)					Ref
-2	800750	• Group, Water System (See Group 30, Figure 02 for DET)					1
3	W-105526	• Assembly, Boom High Pressure Filter					1
4	W-105527	• • Element, Boom High Pressure Filter					1
5	W-105556	• Indicator, Boom High Pressure Filter Visual Clogging					1
6	73300	• Assembly, Hydraulic Filter					2
7	73303	• • Element, Hydraulic Filter					1
8	800651	• Assembly, Hydraulic Oil Cooler					1
9	79276	• Gauge, Return Filter Indicator					2
10	79245	• Assembly, Return Filter					1
11	79269	• • Element, Return Filter					2
12	W-104847	• Assembly, Swing Tube Manifold					1
13	W-105573	• Assembly, Swing Tube Circuit Solenoid Valve					1
14	W-105581	• • Pilot, Solenoid Valve					1
15	W-105576	• • • Coil, Swing Tube Circuit Solenoid Valve					2
16	W-105572	• Cartridge, Solenoid Valve					1
17	W-105605	• • Coil					1
18	W-105579	• Valve, HP Limiter					1
19	W-103616	• Accumulator					1
20	71460	• Kit, Accumulator Charge (Optional Item) (See Group 80, Figure 02 for REF)					1
21	73171	• Bracket, Accumulator					A/R
22	W-105582	• Valve, Proportional Pilot					1
23	W-105606	• • Coil					1
24	W-105581	• Assembly, Pump Control Solenoid Valve					1
25	W-105576	• • Coil, Pump Control Solenoid Valve					2
26	W-104846	• Assembly, Pump Control Manifold					1
27	W-105570	• Cartridge, Relief Valve					1
28	W-105577	• Cartridge, Check Valve					1
29	W-105578	• Valve, Ball					1

DASH (-) ITEM NOT ILLUSTRATED

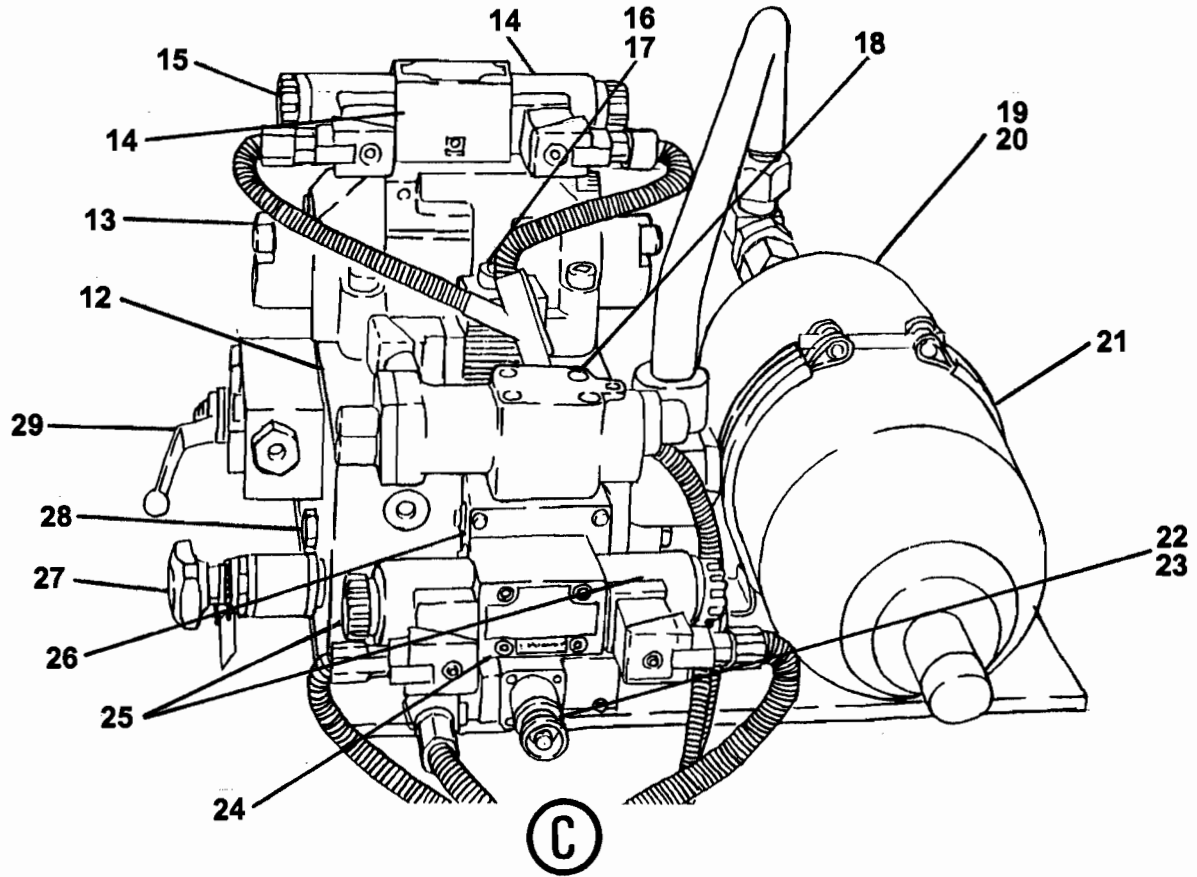
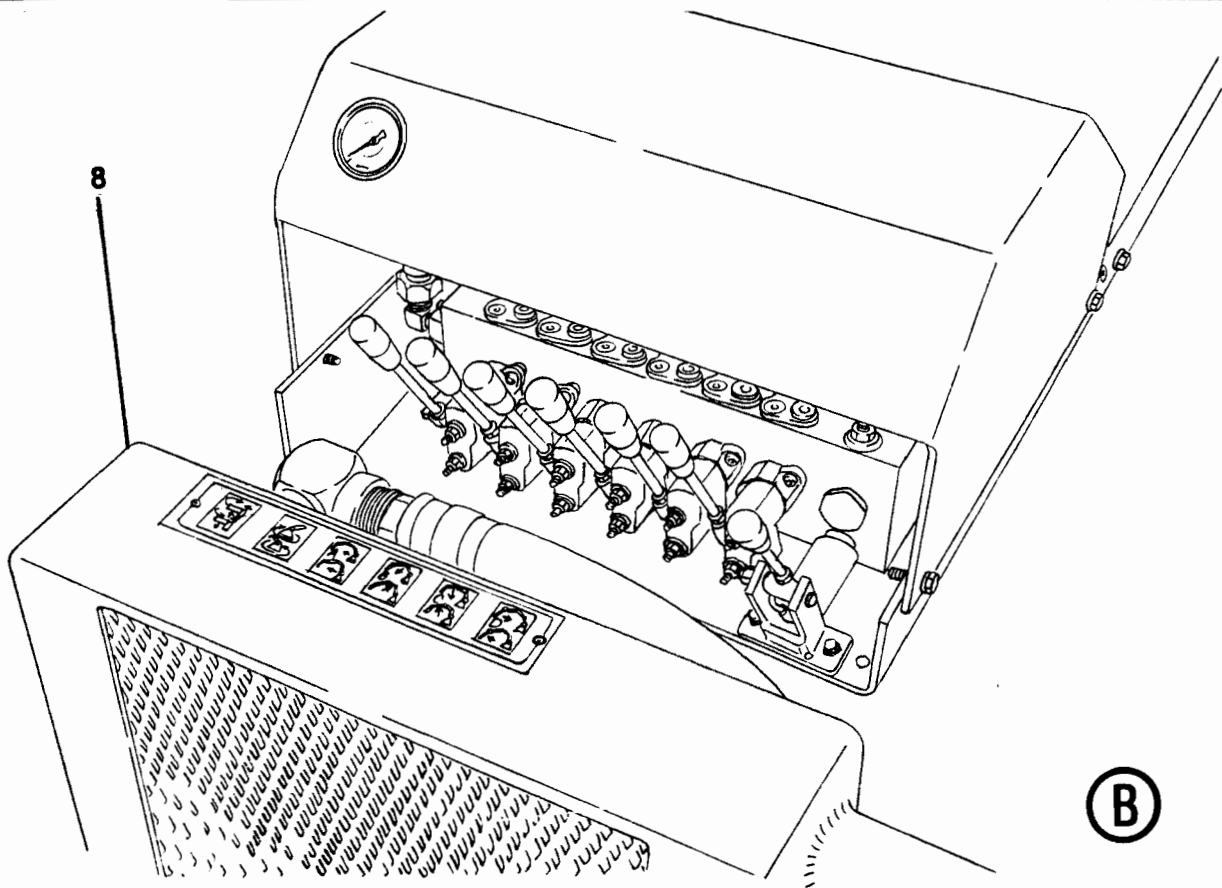

ITEM NO.	REED'S PARTS NO.	DESCRIPTION					QTY
		1	2	3	4	5	
-1	30-01	Installation, Tank (See Group 10, Figure 01 for NHA)					Ref
-2	800750	• Group, Water System (See Group 30, Figure 02 for DET)					1
3	W-105526	• Assembly, Boom High Pressure Filter					1
4	W-105527	• • Element, Boom High Pressure Filter					1
5	W-105556	• Indicator, Boom High Pressure Filter Visual Clogging					1
6	73300	• Assembly, Hydraulic Filter					2
7	73303	• • Element, Hydraulic Filter					1
8	800651	• Assembly, Hydraulic Oil Cooler					1
9	79276	• Gauge, Return Filter Indicator					2
10	79245	• Assembly, Return Filter					1
11	79269	• • Element, Return Filter					2
12	W-104847	• Assembly, Swing Tube Manifold					1
13	W-105573	• Assembly, Swing Tube Circuit Solenoid Valve					1
14	W-105581	• • Pilot, Solenoid Valve					1
15	W-105576	• • • Coil, Swing Tube Circuit Solenoid Valve					2
16	W-105572	• Cartridge, Solenoid Valve					1
17	W-105605	• • Coil					1
18	W-105579	• Valve, HP Limiter					1
19	W-103616	• Accumulator					1
20	71460	• Kit, Accumulator Charge (Optional Item) (See Group 80, Figure 02 for REF)					1
21	73171	• Bracket, Accumulator					A/R
22	W-105582	• Valve, Proportional Pilot					1
23	W-105606	• • Coil					1
24	W-105581	• Assembly, Pump Control Solenoid Valve					1
25	W-105576	• • Coil, Pump Control Solenoid Valve					2
26	W-104846	• Assembly, Pump Control Manifold					1
27	W-105570	• Cartridge, Relief Valve					1
28	W-105577	• Cartridge, Check Valve					1
29	W-105578	• Valve, Ball					1

DASH (-) ITEM NOT ILLUSTRATED



WATER SYSTEM GROUP

XXT 32
PARTS
GROUP 30
FIGURE 02
PAGE 01

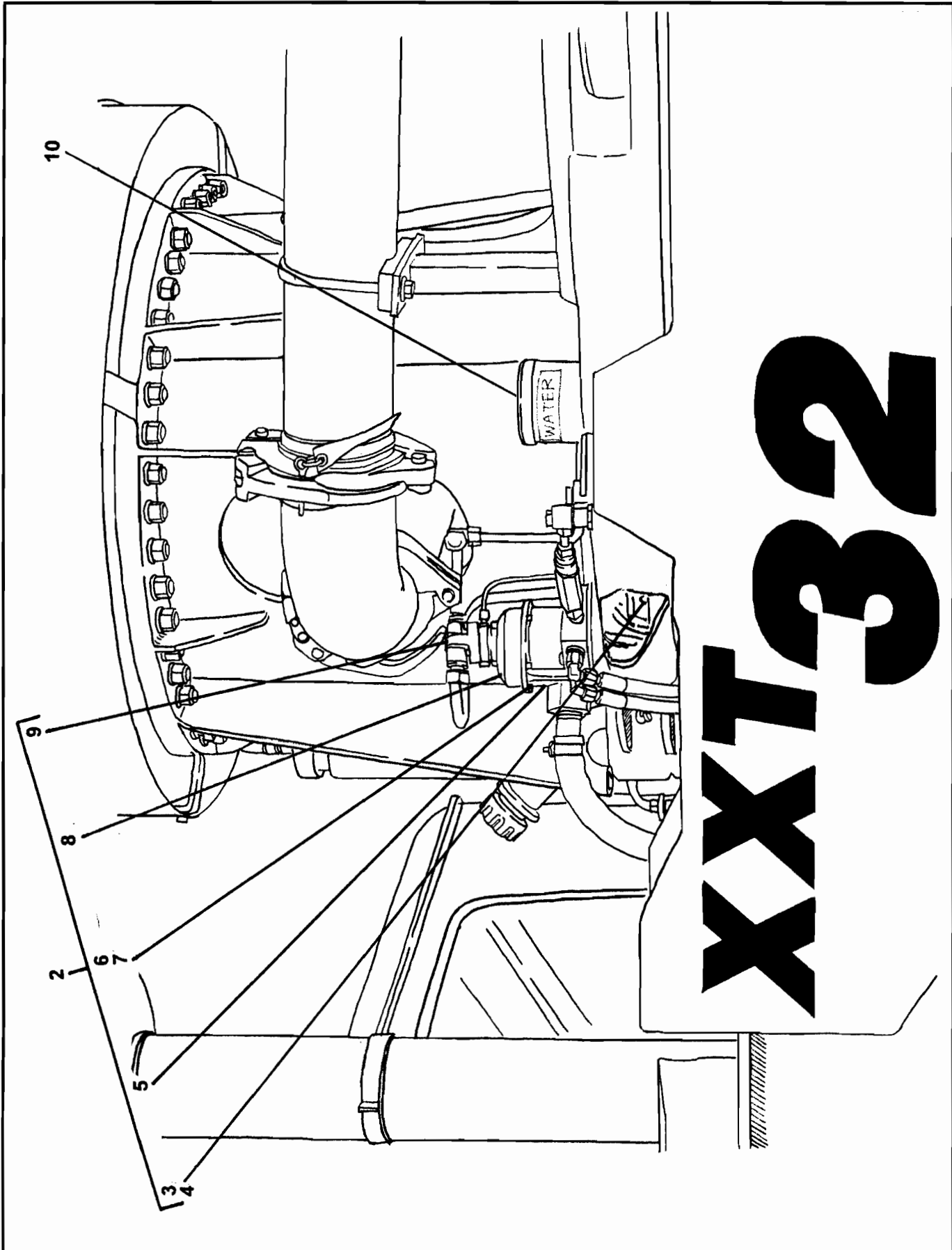

XXT 32

REVISION:

ITEM NO.	REED'S PARTS NO.	1 2 3 4 5	DESCRIPTION	QTY
-1	800750		Group, Water System (See Group 30, Figure 01 for NHA)	Ref
2	W-104176	•	Assembly, Water Pump And Drive	1
3	B-321502	• •	Coupling	1
4	W-103646	• •	Screw, M6	2
5	W-100122	• •	Assembly, Wash Water Pump (See Group 30, Figure 03 for DET)	1
6	W-101838	• •	Screw, M6	8
7	W-103674	• •	Washer, Spring	8
8	B-321505	• •	Flange	1
9	W-100121	• •	Assembly, Water Pump Motor (See Group 30, Figure 04 for DET)	1
10	W-103102	•	Cap, Fill	1

DASH (-) ITEM NOT ILLUSTRATED

REED

WASH WATER PUMP ASSEMBLY

XXT 32
PARTS
GROUP 30
FIGURE 03
PAGE 01

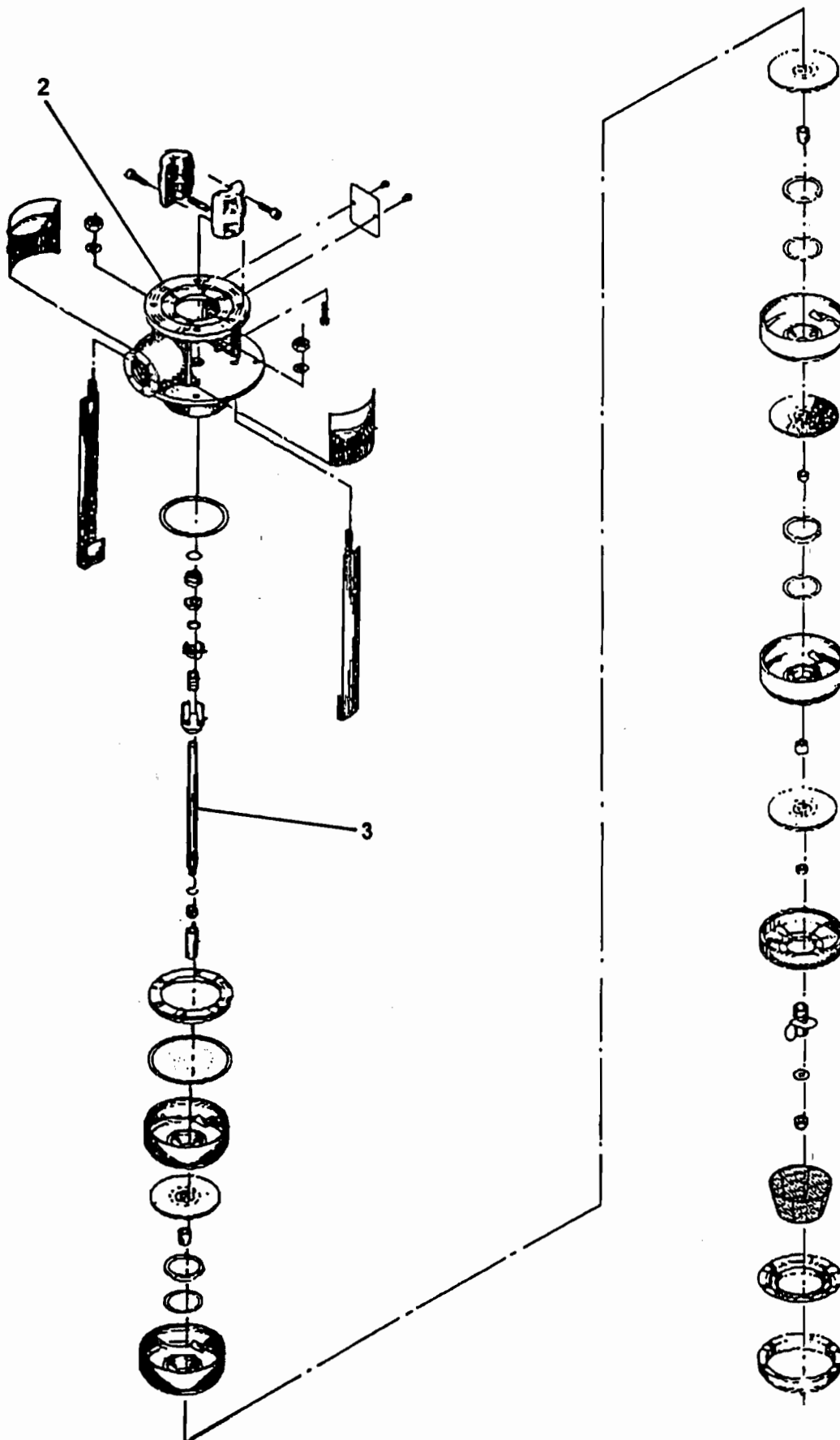

REVISION:

REED**WASH WATER PUMP ASSEMBLY****XXT 32****PARTS**

GROUP 30

FIGURE 03

PAGE 02

ITEM NO.	REED'S PARTS NO.	DESCRIPTION					QTY
		1	2	3	4	5	
-1	W-100122	Assembly, Wash Water Pump (See Group 30, Figure 02 for NHA)					Ref
2	W-105221	• Housing, Pump					1
3	W-105222	• Shaft, Pump					1

DASH (-) ITEM NOT ILLUSTRATED

REVISION:



WATER PUMP MOTOR ASSEMBLY

XXT 32
PARTS
GROUP 30
FIGURE 04
PAGE 01

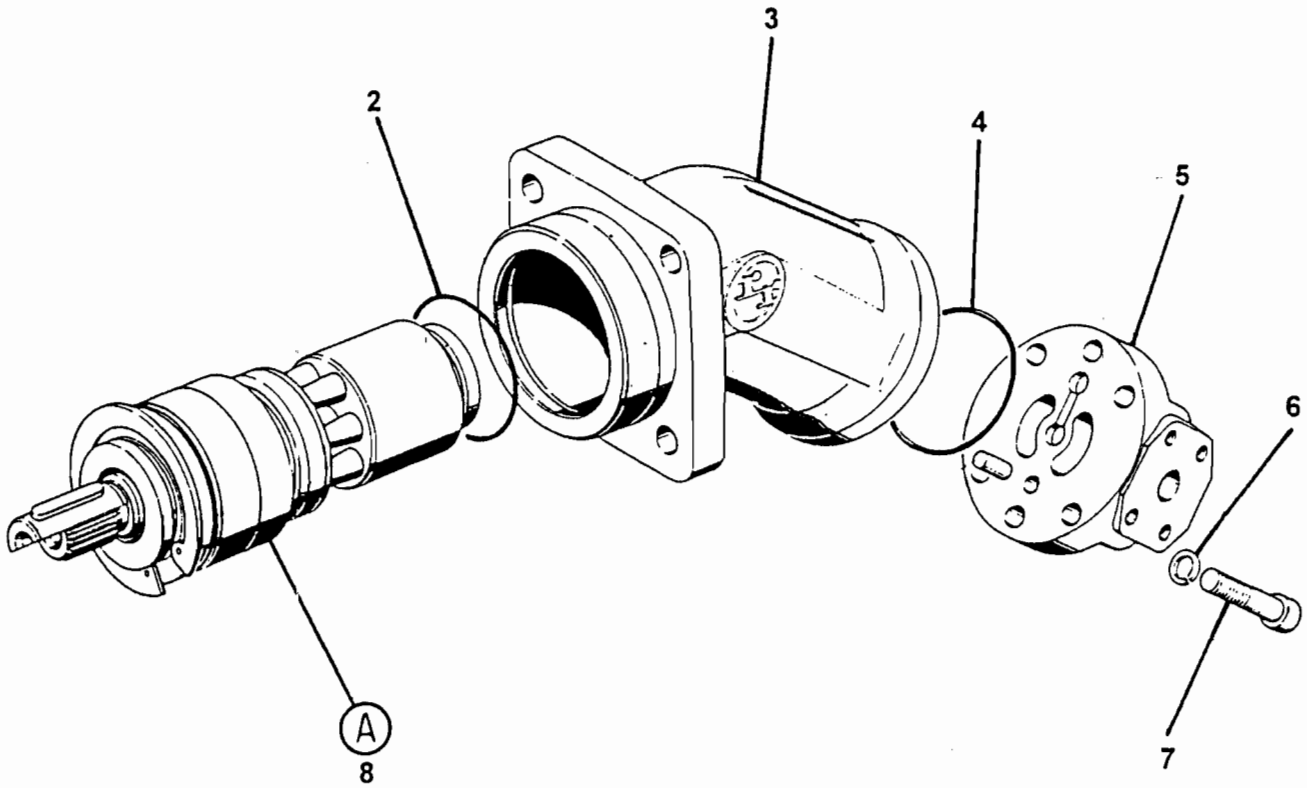

ITEM NO.	REED'S PARTS NO.	DESCRIPTION					QTY
		1	2	3	4	5	
-1	W-100121	Assembly, Water Pump Motor (See Group 30, Figure 02 for NHA)					Ref
2		• O-Ring					1
3		• Housing					1
4		• O-Ring					1
5		• Plate, Port					1
6		• Washer, Lock					4
7		• Screw, M6					4
8		• Sub-Assembly, Rotary					1
9		• • Ring Retaining					1
10		• • Cover					1
11		• • Ring, Shaft Seal					1
12		• • Ring Retaining					1
13		• • Bearing, Tapered Roller					1
14		• • Shim					2
15		• • Shim					2
16		• • Shim					2
17		• • Bearing, Angular Contact Ball					2
18		• • Key, Shaft					1
19		• + Shaft, Drive					1
20		• • Disc					1
21		• • Plate, Retaining					1
22		• • Rivet					7
23		• • Pin, Center					1
24		• • Cup, Spring					4
25		• • Collar, Spring					1
26		• • Shim					1
27		• • Piston					7
28		• • Ring, Steel Sealing					7
29		• • Cylinder					1
30		• • Plate, Control					1
31		• Pin					1

DASH (-) ITEM NOT ILLUSTRATED

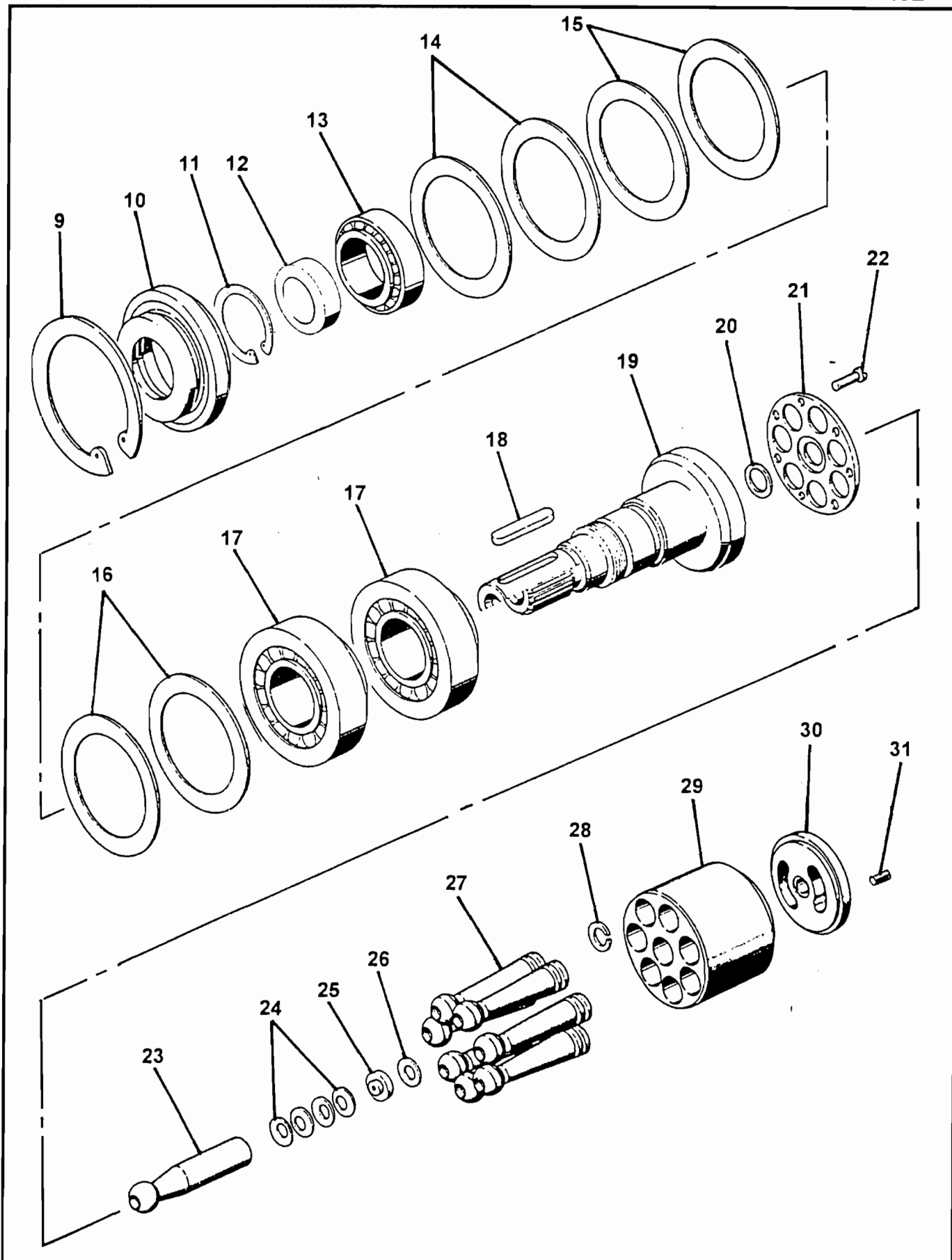

ITEM NO.	REED'S PARTS NO.	DESCRIPTION	QTY
-1	W-100121	Assembly, Water Pump Motor (See Group 30, Figure 02 for NHA)	Ref
2		• O-Ring	1
3		• Housing	1
4		• O-Ring	1
5		• Plate, Port	1
6		• Washer, Lock	4
7		• Screw, M6	4
8		• Sub-Assembly, Rotary	1
9		•• Ring Retaining	1
10		•• Cover	1
11		•• Ring, Shaft Seal	1
12		•• Ring Retaining	1
13		•• Bearing, Tapered Roller	1
14		•• Shim	2
15		•• Shim	2
16		•• Shim	2
17		•• Bearing, Angular Contact Ball	2
18		•• Key, Shaft	1
19		•• Shaft, Drive	1
20		•• Disc	1
21		•• Plate, Retaining	1
22		•• Rivet	7
23		•• Pin, Center	1
24		•• Cup, Spring	4
25		•• Collar, Spring	1
26		•• Shim	1
27		•• Piston	7
28		•• Ring, Steel Sealing	7
29		•• Cylinder	1
30		•• Plate, Control	1
31		•• Pin	1

DASH (-) ITEM NOT ILLUSTRATED

REED

**MODEL XXT 32 TRUCK MOUNTED
CONCRETE BOOM PUMP
ILLUSTRATED PARTS MANUAL**

**XXT 32
PARTS
GROUP 30
FIGURE 05
PAGE 01**

THIS PAGE INTENTIONALLY LEFT BLANK.

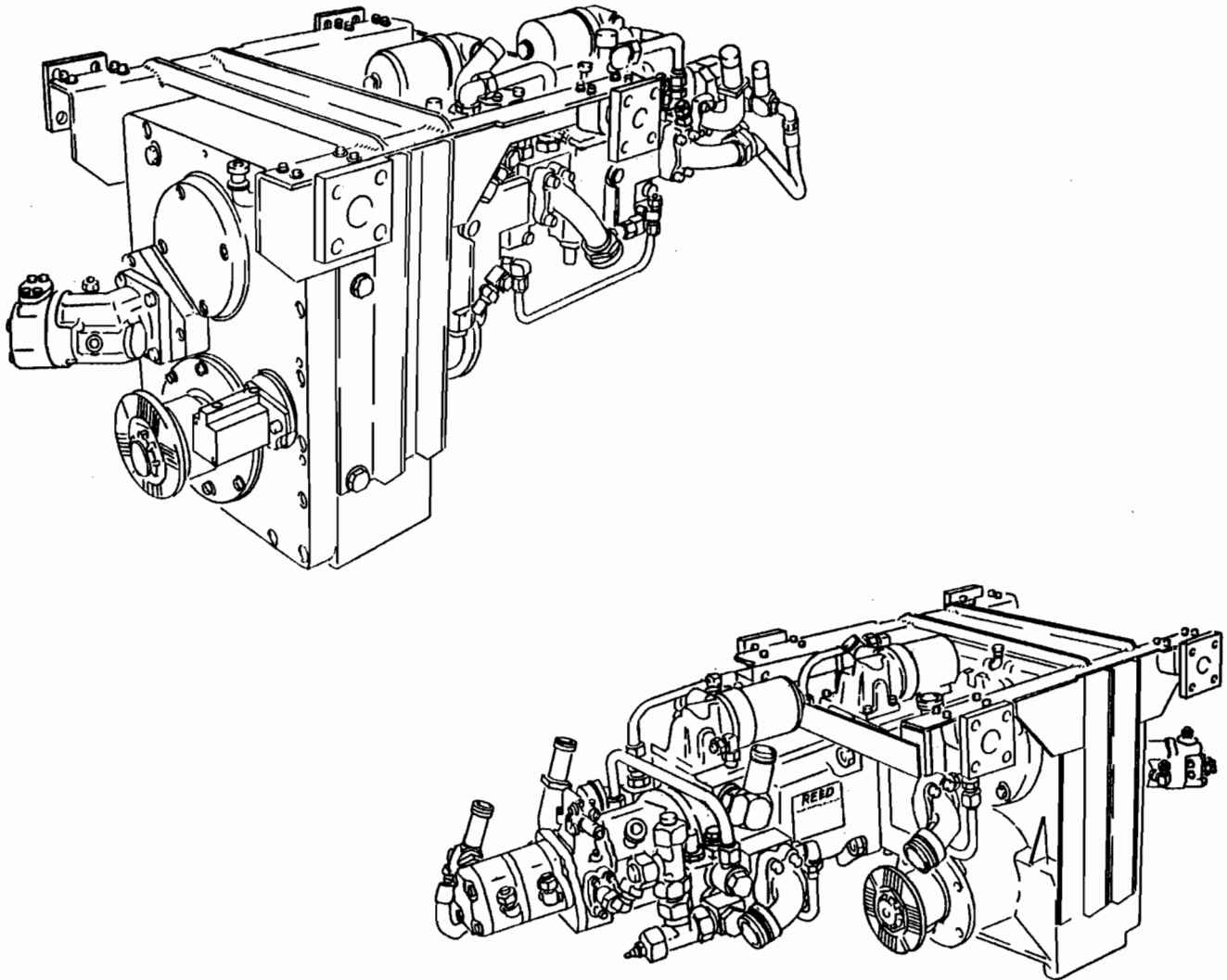

SHOWN MODEL: AFTER MARCH 2001

REED TRUCK MOUNTED CONCRETE BOOM PUMP MODEL XXT 32 ILLUSTRATED PARTS MANUAL GROUP 40 POWER TRAIN INSTALLATION CONTAINS THE FOLLOWING FIGURES:

FIGURE 00	TABLE OF CONTENTS
FIGURE 01	POWER TRAIN INSTALLATION (BEF JUL 1999)
FIGURE 02	POWER TRAIN INSTALLATION (AUG 1999 ~ MAR 2000)
FIGURE 03	POWER TRAIN INSTALLATION (APR 2000 ~ FEB 2001)
FIGURE 04	POWER TRAIN INSTALLATION (AFT MAR 2001)
FIGURE 05	GEAR PUMP ASSEMBLY
FIGURE 06	PTO GEARBOX ASSEMBLY

BEFORE JULY 1999

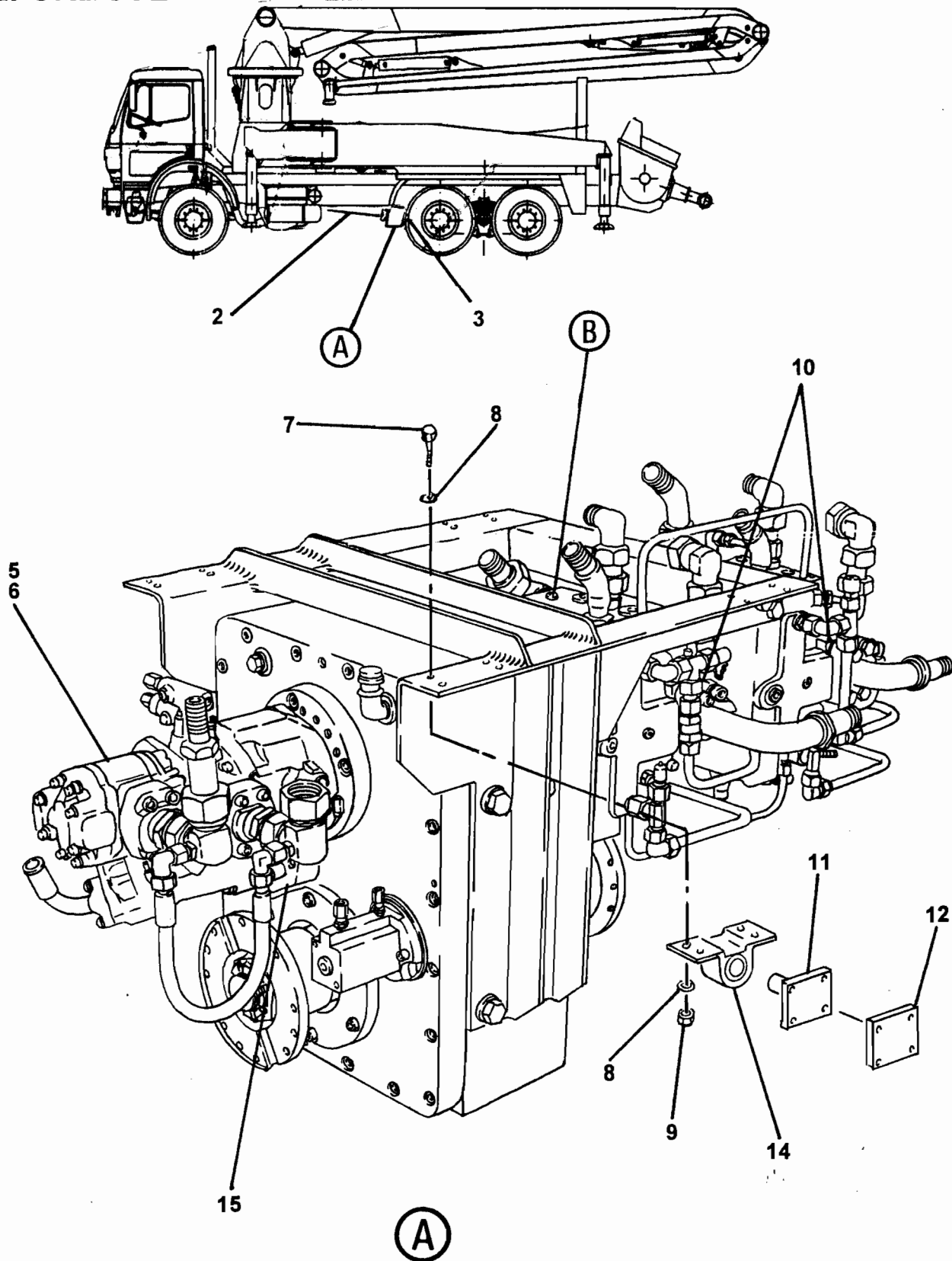

BEFORE JULY 1999

ITEM NO.	REED'S PARTS NO.	DESCRIPTION					QTY
		1	2	3	4	5	
-1	40-01	Installation, Power Train (Before Jul 1999) (See Group 10, Figure 01 for NHA)					Ref
2	801059	• Shaft, Front Drive					1
3	801289	• Shaft, Rear Drive					1
4	800607	• Group, XXT 32 Gearbox					1
5	801022	• Assembly, Gear Pump					1
6	800061	• • O-Ring					1
7		• • Bolt, Hex					16
8		• • Washer					32
9		• • Nut, Lock					16
10	801057	• • Manifold, Pump					3
11	800125	• • Axle, PTO Mount					4
12	800128	• • Plate, PTO Axle Mount					4
13	W-105055	• • Assembly, PTO Gearbox with Rexroth					1
14	W-103414	• • • Buffer, Rubber					4
15	W-104703	• • • Assembly, S-Tube Circuit Pump					1
16	W-103511	• • • Assembly, Boom Pump					1
17	W-104527	• • • Assembly, PTO Gearbox					1
18	W-105513	• • • • Switch, PTO Gearbox					1
19	W-104704	• • • Assembly, Rexroth Pump					2
20	W-104949	• • • Valve, Main Pump Flushing					1
21	801087	• • Mount, PTO Gearbox with Rexroth					1
22	801058	• • Manifold, Boom Pump					1
23	801088	• • Brace, PTO Mount					1
-24	800063	• • Valve, Air					1
-25	800064	• • Muffler, Air Valve					1

DASH (-) ITEM NOT ILLUSTRATED

BEFORE JULY 1999

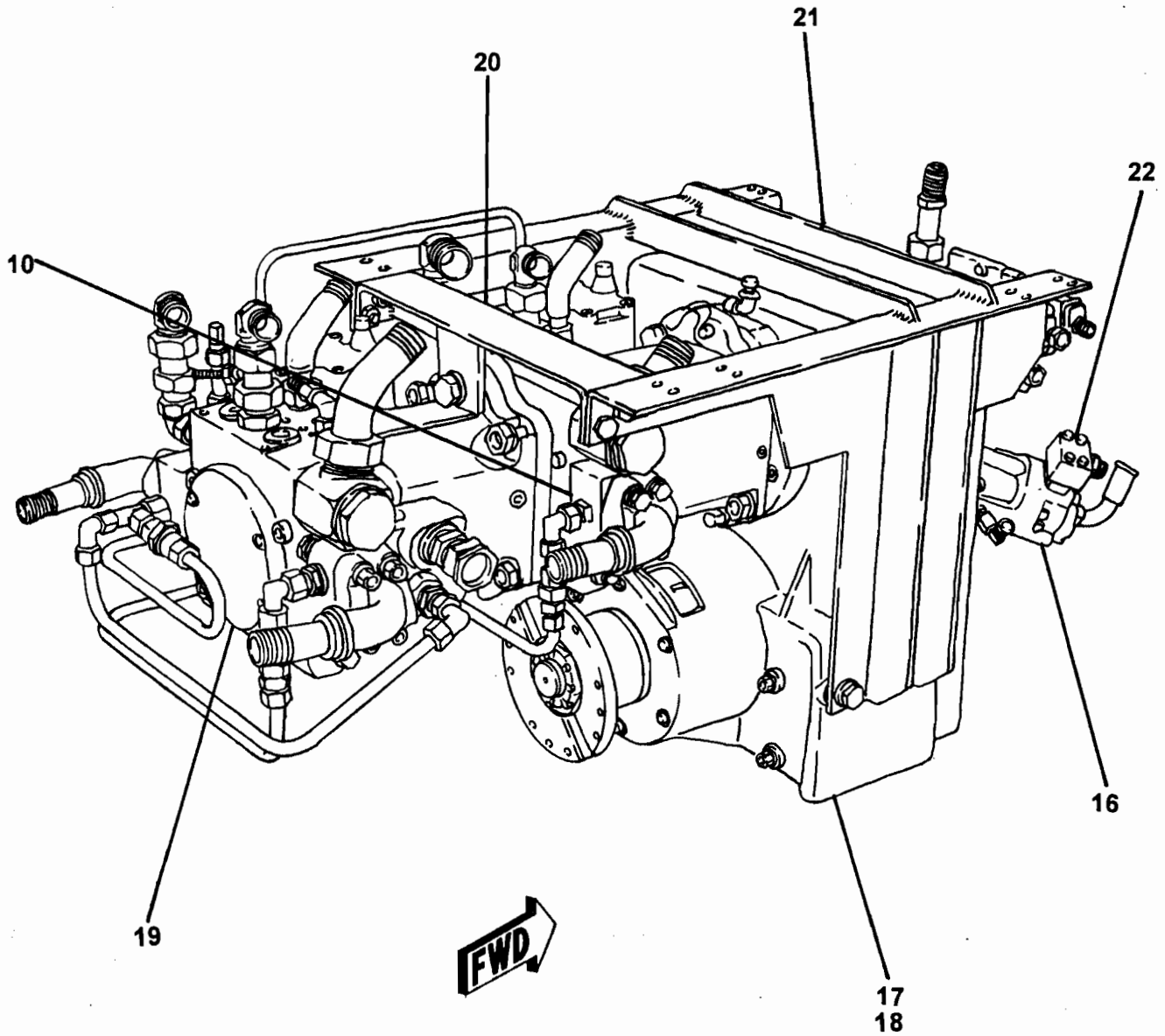

BEFORE JULY 1999

ITEM NO.	REED'S PARTS NO.	DESCRIPTION					QTY
		1	2	3	4	5	
-1	40-01	Installation, Power Train (Before Jul 1999) (See Group 10, Figure 01 for NHA)					Ref
2	801059	• Shaft, Front Drive					1
3	801289	• Shaft, Rear Drive					1
4	800607	• Group, XXT 32 Gearbox					1
5	801022	• Assembly, Gear Pump					1
6	800061	•• O-Ring					1
7		•• Bolt, Hex					16
8		•• Washer					32
9		•• Nut, Lock					16
10	801057	•• Manifold, Pump					3
11	800125	•• Axle, PTO Mount					4
12	800128	•• Plate, PTO Axle Mount					4
13	W-105055	•• Assembly, PTO Gearbox with Rexroth					1
14	W-103414	••• Buffer, Rubber					4
15	W-104703	••• Assembly, S-Tube Circuit Pump					1
16	W-103511	••• Assembly, Boom Pump					1
17	W-104527	••• Assembly, PTO Gearbox					1
18	W-105513	•••• Switch, PTO Gearbox					1
19	W-104704	••• Assembly, Rexroth Pump					2
20	W-104949	••• Valve, Main Pump Flushing					1
21	801087	•• Mount, PTO Gearbox with Rexroth					1
22	801058	•• Manifold, Boom Pump					1
23	801088	•• Brace, PTO Mount					1
-24	800063	•• Valve, Air					1
-25	800064	•• Muffler, Air Valve					1

DASH (-) ITEM NOT ILLUSTRATED

AUGUST 1999 ~ MARCH 2000

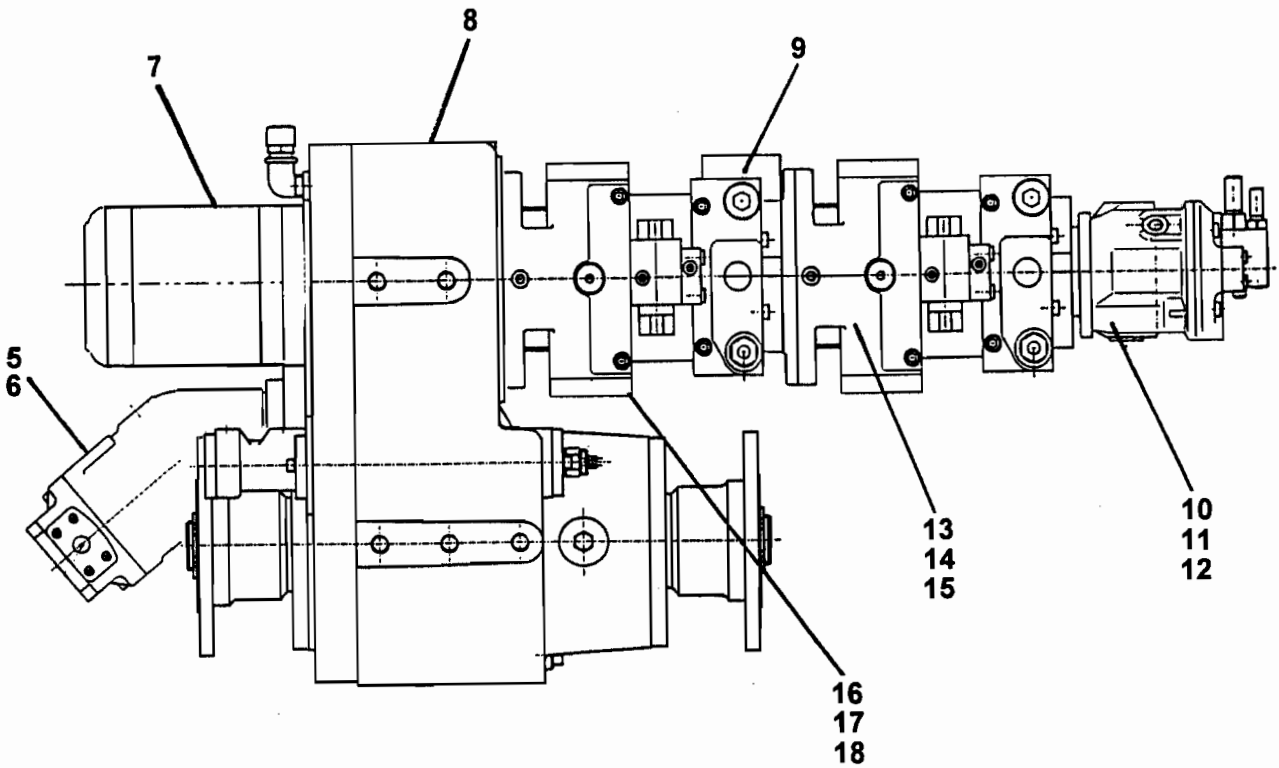
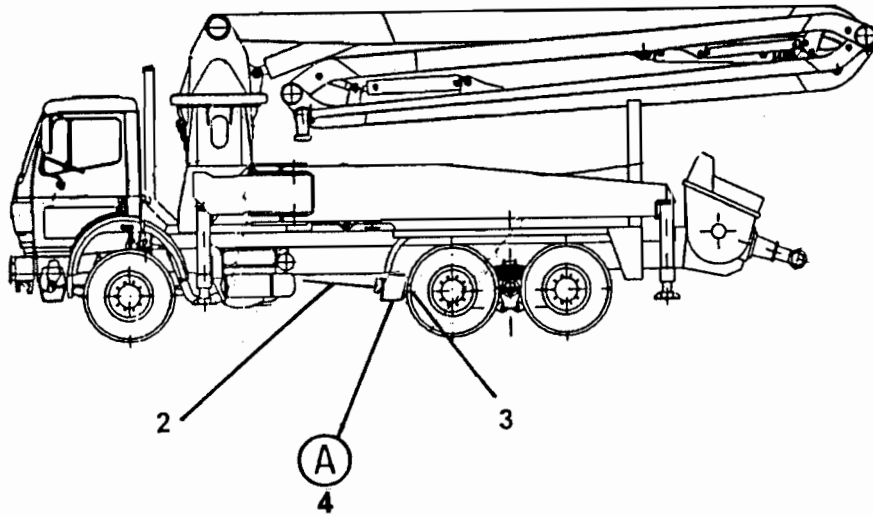

(A)

AUGUST 1999 ~ MARCH 2000

ITEM NO.	REED'S PARTS NO.	DESCRIPTION					QTY
		1	2	3	4	5	
-1	40-02	Installation, Power Train (Aug 1999 ~ Mar 2000) (See Group 10, Figure 01 for NHA)					Ref
2	801480	• Shaft, Front Drive					1
3	801481	• Shaft, Rear Drive					1
4	W-105340	• Group, XXT 32 Gearbox (Aug 1999 ~ Mar 2000)					1
5	W-103623	• • Assembly, Boom Pump					1
6	801058	• • Manifold, Boom Pump					1
7	801397	• • Assembly, 4/4CC Gear Pump					1
8	W-104870	• • Assembly, PTO Gearbox					1
9	W-104949	• • Valve, Flushing					1
10	W-105594	• • Assembly, A10VO28 Gear Pump					1
11	W-105789	• • • Kit, A10VO28 Gear Pump Seal					1
12	W-105001	• • • Seal, Shaft					1
13	W-105592	• • Assembly, A4VG125 Gear Pump					1
14	W-105787	• • • Kit, A4VG125Gear Pump Seal					1
15	W-105788	• • • Seal, Shaft					1
16	W-105591	• • Assembly, A4VG125 Gear Pump					1
17	W-105785	• • • Kit, A4VG125Gear Pump Seal					1
18	W-105786	• • • Seal, Shaft					1

DASH (-) ITEM NOT ILLUSTRATED

APRIL 2000 ~ FEBRUARY 2001

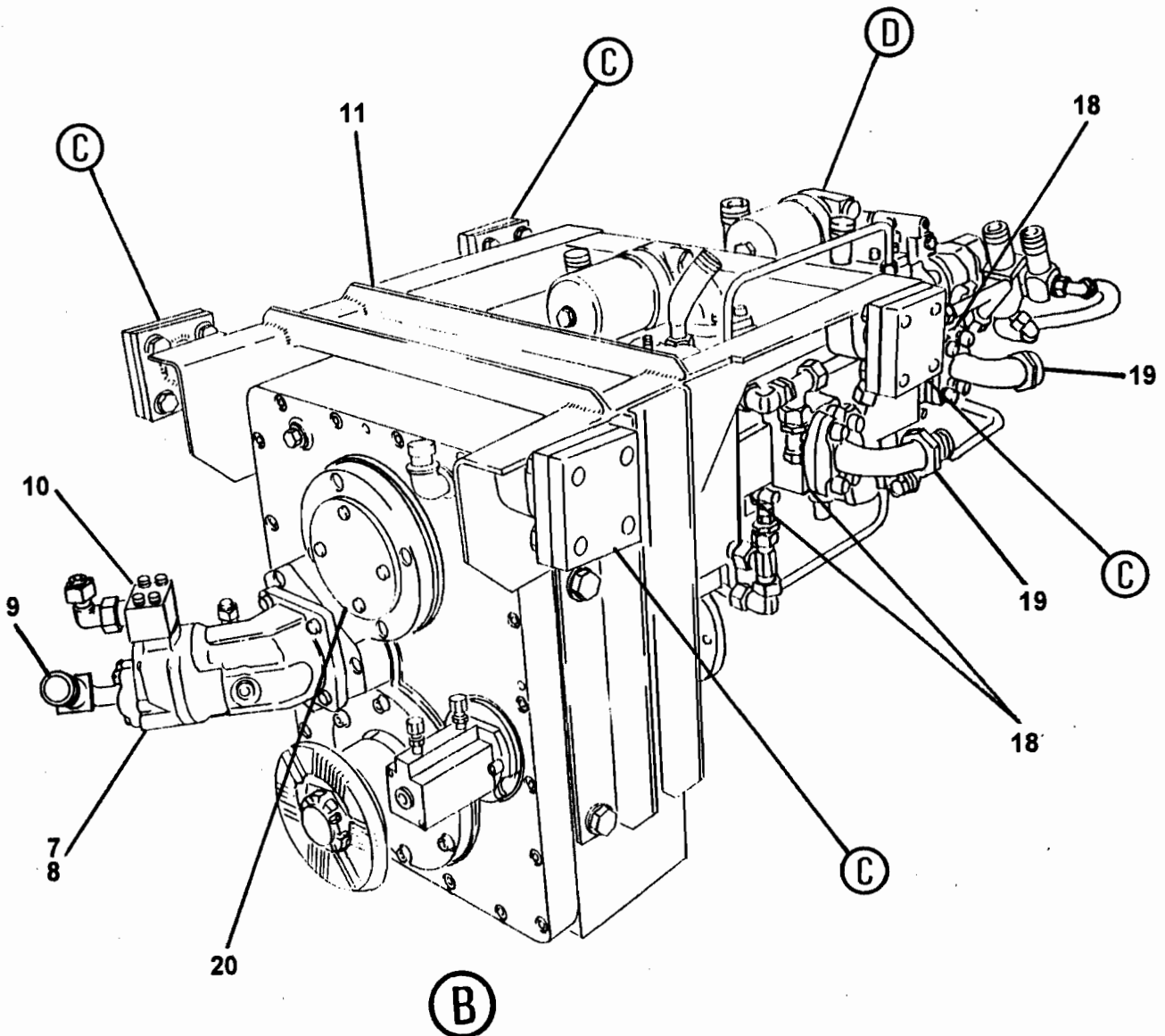
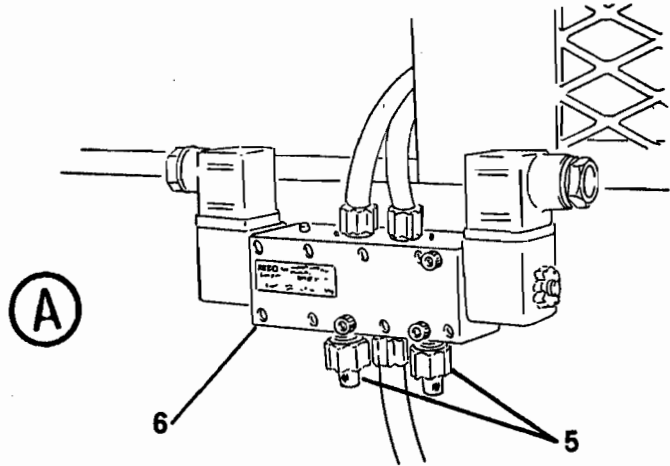
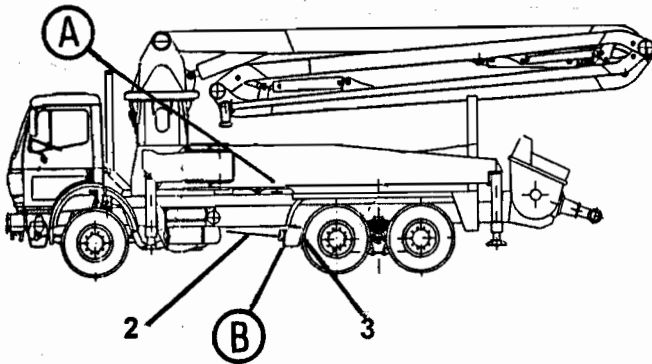

APRIL 2000 ~ FEBRUARY 2001

ITEM NO.	REED'S PARTS NO.	DESCRIPTION					QTY
		1	2	3	4	5	
-1	40-03	Installation, Power Train (Apr 2000 ~ Feb 2001) (See Group 10, Figure 01 for NHA)					Ref
2	801973	• Shaft, Front Drive					1
3	801974	• Shaft, Rear Drive					1
-4	800610	• Group, XXT 36 Gearbox					1
5	800064	• • Muffler, Air Valve					2
6	800063	• • Valve, Air					1
7	W-103623	• • Assembly, Boom Pump					1
8	W-105629	• • • Seal, Boom Pump Shaft					1
9	801511	• • Adapter, 90L					1
10	801058	• • Manifold, Boom Pump					1
11	801087	• • Mount, PTO Gearbox with Rexroth					1
12		• • Bolt, Hex					16
13		• • Washer					32
14		• • Nut, Lock					16
15	W-103414	• • Buffer, Rubber					4
16	800125	• • Axle, PTO Mount					4
17	800128	• • Plate, PTO Axle Mount					4
18	801778	• • Manifold, Pump					2
19	801503	• • Adapter, 90L					4
20	75861	• • Cover, Bolt Housing					1
21	801510	• • Adapter, 90L					1
22	801516	• • Adapter, STR					1
23	801684	• • Assembly, 4/4CC Gear Pump					1
24	800061	• • • O-Ring, Gear Pump					1
25	801512	• • Adapter, 90L					1
26	W-105650	• • Assembly, Gear Pump (See Group 40, Figure 05 for DET)					1
27	801506	• • Adapter, 90L					2
28	801526	• • Adapter, STR					2
29	801527	• • Adapter, STR					1
30	801057	• • Manifold, Pump					2
31	W-105539	• • Assembly, PTO Gearbox (See Group 40, Figure 06 for DET)					1
32	W-105513	• • • Switch, PTO Gearbox					1
33	801499	• • Filter, Charge Pump					2
34	801500	• • • Element, Charge Pump Filter					2
35	801088	• • Brace, PTO Mount					1
36	W-105075	• • Adapter, 90L					1

DASH (-) ITEM NOT ILLUSTRATED

AUGUST 1999 ~ MARCH 2000

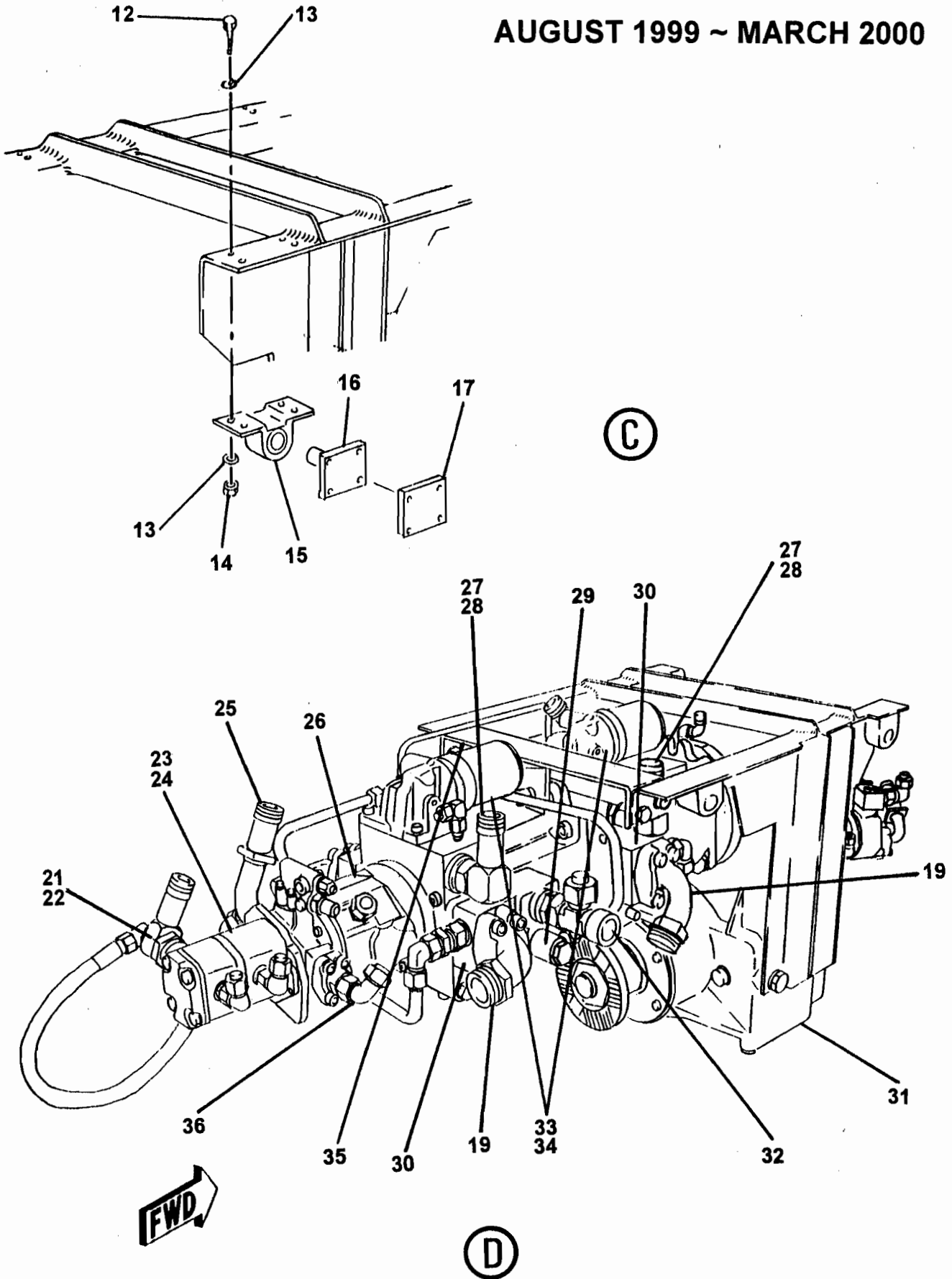

APRIL 2000 ~ FEBRUARY 2001

ITEM NO.	REED'S PARTS NO.	DESCRIPTION	QTY
-1	40-03	Installation, Power Train (Apr 2000 ~ Feb 2001) (See Group 10, Figure 01 for NHA)	Ref
2	801973	• Shaft, Front Drive	1
3	801974	• Shaft, Rear Drive	1
-4	800610	• Group, XXT 36 Gearbox	1
5	800064	• • Muffler, Air Valve	2
6	800063	• • Valve, Air	1
7	W-103623	• • Assembly, Boom Pump	1
8	W-105629	• • • Seal, Boom Pump Shaft	1
9	801511	• • Adapter, 90L	1
10	801058	• • Manifold, Boom Pump	1
11	801087	• • Mount, PTO Gearbox with Rexroth	1
12		• • Bolt, Hex	16
13		• • Washer	32
14		• • Nut, Lock	16
15	W-103414	• • Buffer, Rubber	4
16	800125	• • Axle, PTO Mount	4
17	800128	• • Plate, PTO Axle Mount	4
18	801778	• • Manifold, Pump	2
19	801503	• • Adapter, 90L	4
20	75861	• • Cover, Bolt Housing	1
21	801510	• • Adapter, 90L	1
22	801516	• • Adapter, STR	1
23	801684	• • Assembly, 4/4CC Gear Pump	1
24	800061	• • • O-Ring, Gear Pump	1
25	801512	• • Adapter, 90L	1
26	W-105650	• • Assembly, Gear Pump (See Group 40, Figure 05 for DET)	1
27	801506	• • Adapter, 90L	2
28	801526	• • Adapter, STR	2
29	801527	• • Adapter, STR	1
30	801057	• • Manifold, Pump	2
31	W-105539	• • Assembly, PTO Gearbox (See Group 40, Figure 06 for DET)	1
32	W-105513	• • • Switch, PTO Gearbox	1
33	801499	• • Filter, Charge Pump	2
34	801500	• • • Element, Charge Pump Filter	2
35	801088	• • Brace, PTO Mount	1
36	W-105075	• • Adapter, 90L	1

DASH (-) ITEM NOT ILLUSTRATED

AFTER MARCH 2001

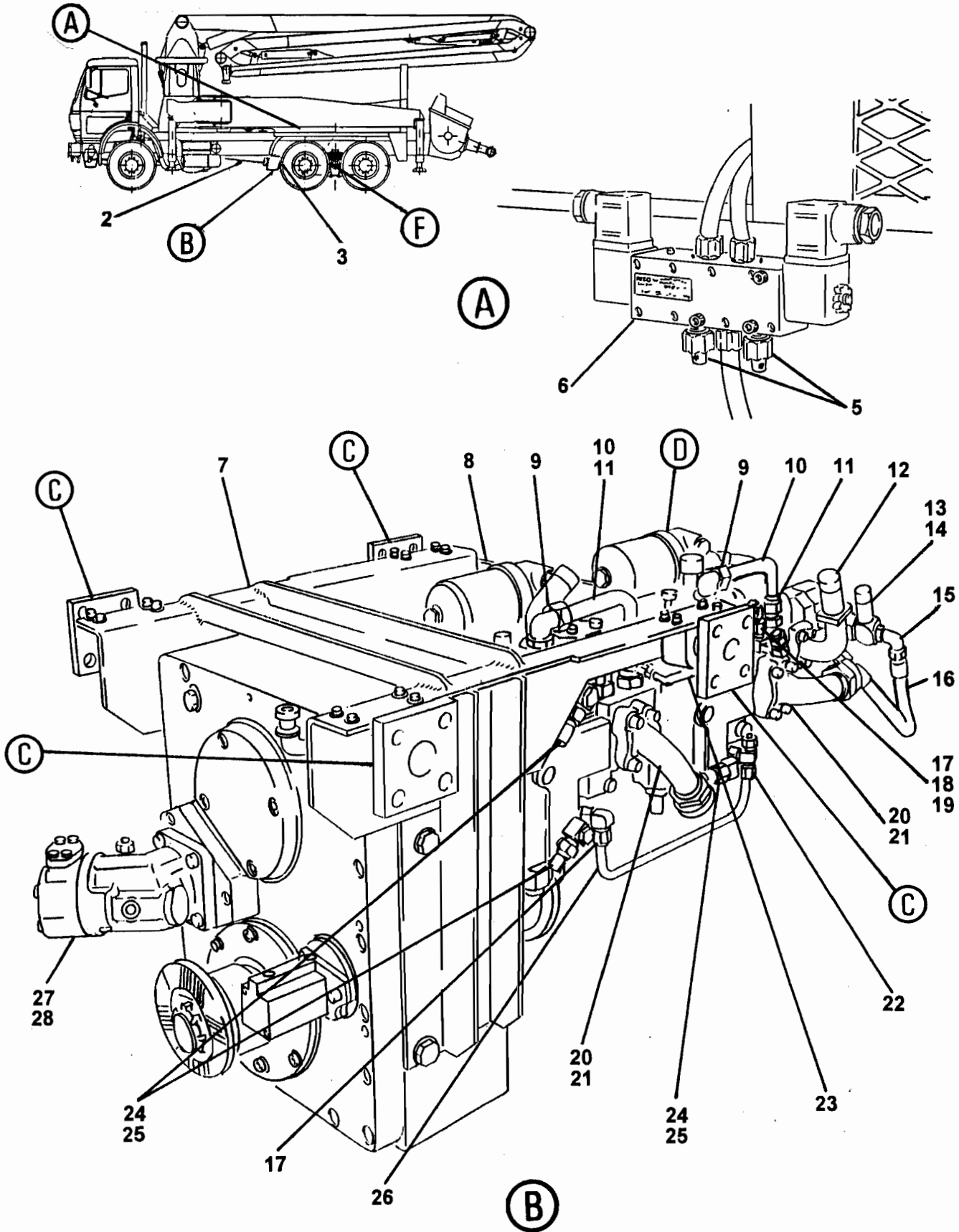



**POWER TRAIN INSTALLATION
(AFTER MARCH 2001)**

**XXT 32
PARTS
GROUP 40
FIGURE 04
PAGE 02**

AFTER MARCH 2001

ITEM NO.	REED'S PARTS NO.	DESCRIPTION					QTY
		1	2	3	4	5	
-1	40-01	Installation, Power Train (Aft Mar 2001) (See Group 10, Figure 01 for NHA)					Ref
2	801973	• Shaft, Front Drive					1
3	801974	• Shaft, Rear Drive					1
-4	800610	• Installation, XXT 32 PTO Gearbox					1
5	800064	• • Muffler, Air Valve					2
6	800063	• • Valve, Air					1
7	801788	• • Mount, PTO Gearbox with Rexroth					1
8	801792	• • Brace, PTO Mount					1
9	801888-005	• • Swivel, Elbow					7
10	801793	• • Assembly, Tube					2
11		• • Adapter, STR					2
12	801512	• • Adapter, 90L					1
13	801510	• • Adapter, 90L					1
14	801516	• • Adapter, STR					1
15	801888-014	• • Swivel, Elbow					3
16	801486-005	• • Assembly, Hose					1
17	801888-003	• • Swivel, Elbow					3
18	801890-003	• • Swivel, Tee					1
19	W-105076	• • Port, Pressure Test					3
20	801778	• • Manifold, Pump					2
21	801503	• • Adapter, 90L					4
22	801889-003	• • Swivel, Tee					1
23	802339	• • Assembly, Tube					1
24	801874-003	• • Banjo					4
25	W-104831	• • Port, Pressure Test					4
26	801797	• • Assembly, Tube					1
27	W-103623	• • Assembly, Boom Pump					1
28	W-105925	• • • Seal, Boom Pump Shaft					1

DASH (-) ITEM NOT ILLUSTRATED

AFTER MARCH 2001

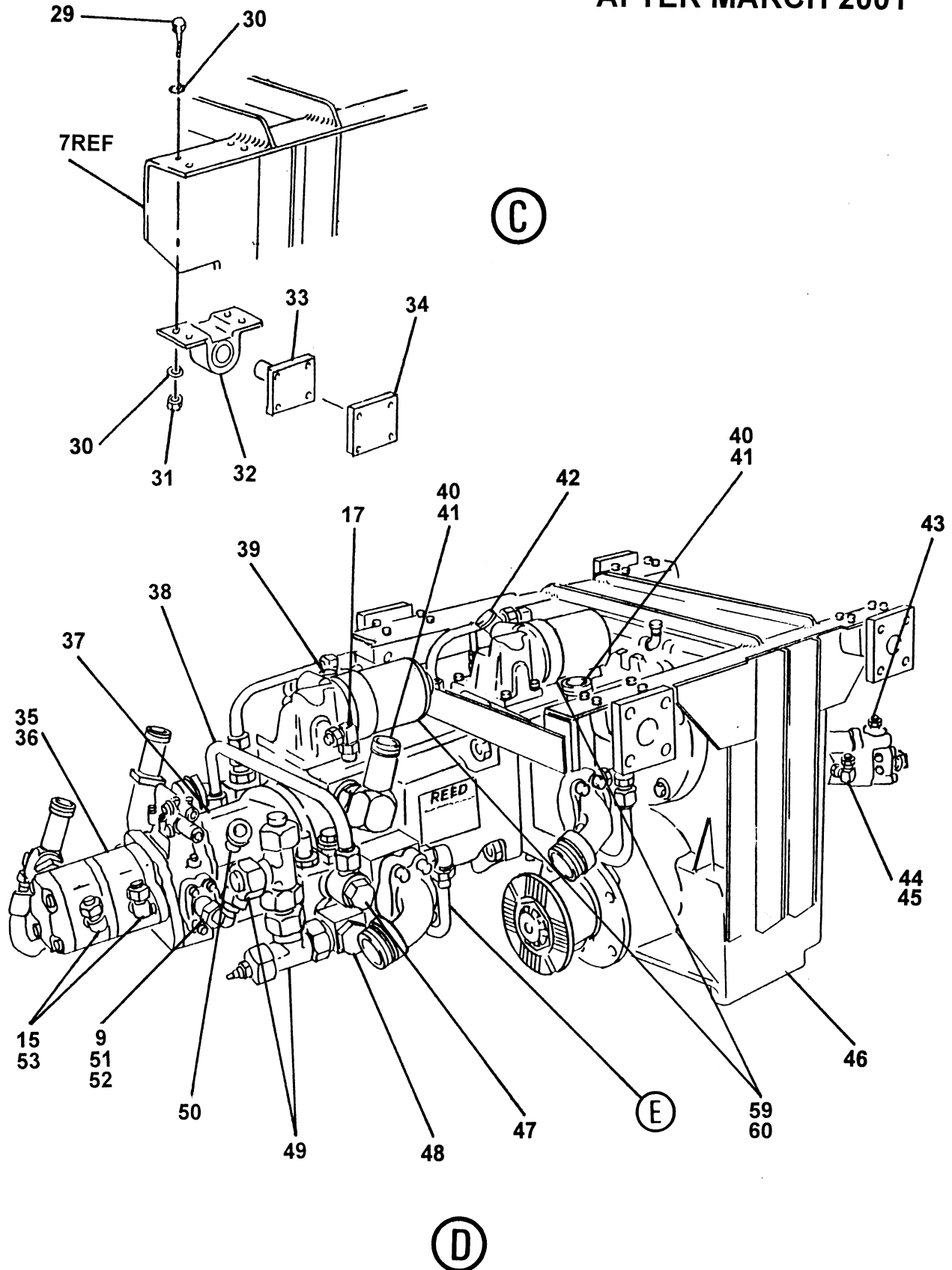



**POWER TRAIN INSTALLATION
(AFTER MARCH 2001)**

**XXT 32
PARTS
GROUP 40
FIGURE 04
PAGE 04**

AFTER MARCH 2001

ITEM NO.	REED'S PARTS NO.	1 2 3 4 5	DESCRIPTION	QTY
29		••	Bolt, Hex	16
30		••	Washer	32
31		••	Nut, Lock	16
32	W-103414	••	Buffer, Rubber	4
33	800125	••	Axle, PTO Mount	4
34	800128	••	Plate, PTO Axle Mount	4
35	801684	••	Assembly, 4/4CC Pump	1
36	800061	•••	O-Ring, 4/4CC Pump	1
37	W-105650	••	Assembly, Gear Pump (See Group 40, Figure 02 for DET)	1
38	801796	••	Assembly, Tube	1
39	W-105170	••	Adapter, STR	1
40	801506	••	Adapter, 90L	2
41	801526	••	Adapter, STR	2
42	W-105169	••	Adapter, 45	1
43	801873-011	••	Adapter	1
44	801524	••	Adapter, STR	1
45	801509	••	Adapter, 90L	1
46	802242	••	Assembly, PTO Gear Box (See Group 40, Figure 03 for DET)	1
47	801527	••	Adapter, STR	1
48		••	Banjo	1
49	801890-006	••	Swivel, Tee	2
50	801876-005	••	Adapter, STR	1
51	86264-002	••	Flange, Split	1
52	W-105075	••	Adapter, STR	1
53	801876-003	••	Adapter	2
54	801057	••	Manifold, Pump	2
55	801794	••	Assembly, Tube	1
56	801795	••	Assembly, Tube	1
57	W-105567	••	Sensor, Thermal	1
58	801927	••	Adapter, Thermal Sensor	1
59	801499	••	Filter, A4VG125 Charge Pump	2
60	801500	•••	Element, A4VG125 Charge Pump Filter	2

DASH (-) ITEM NOT ILLUSTRATED

AFTER MARCH 2001

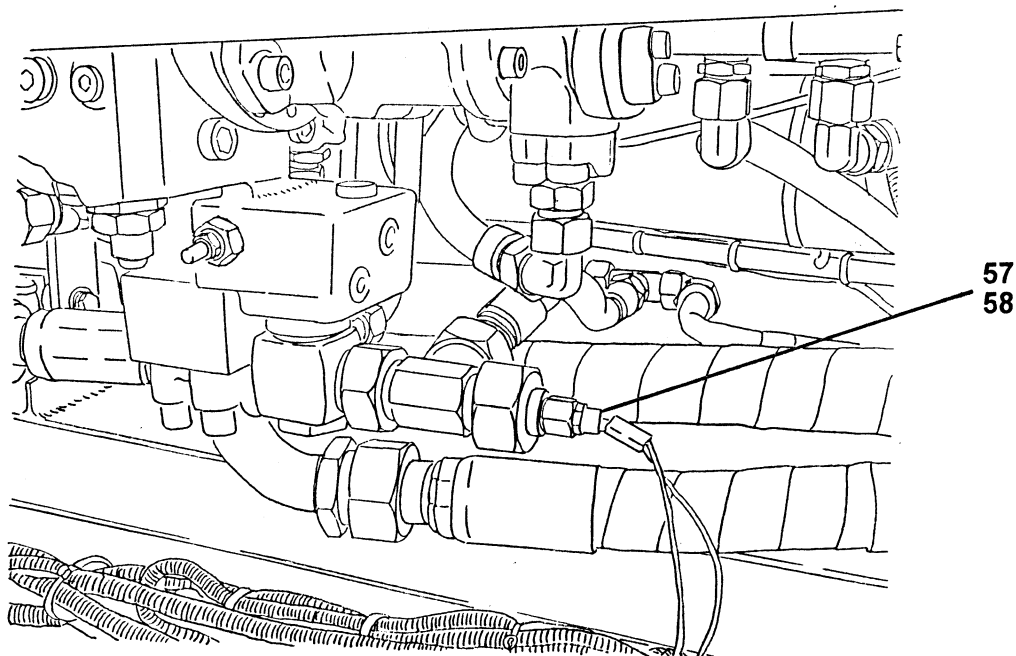
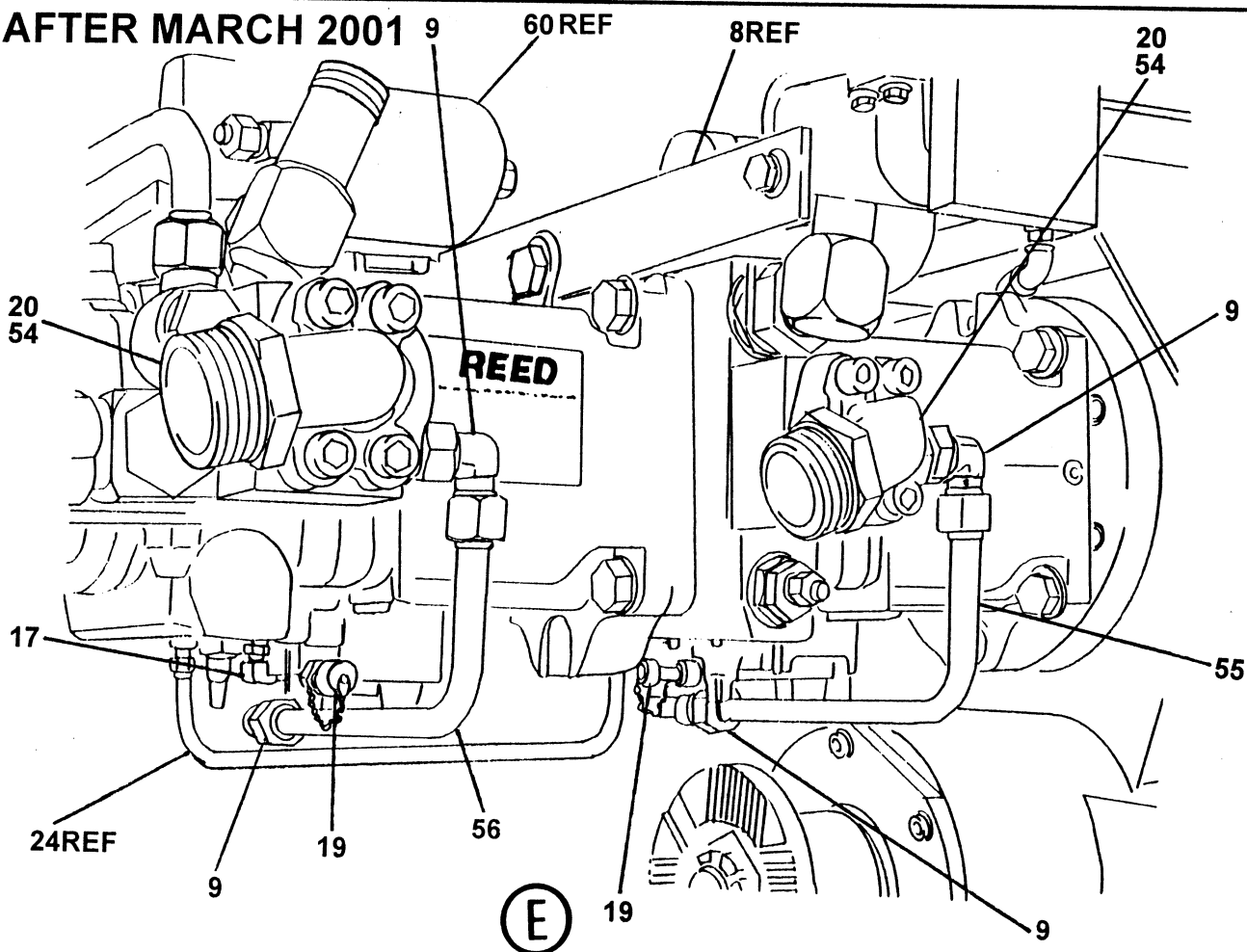

AFTER MARCH 2001

ITEM NO.	REED'S PARTS NO.	1 2 3 4 5	DESCRIPTION	QTY
29		• •	Bolt, Hex	16
30		• •	Washer	32
31		• •	Nut, Lock	16
32	W-103414	• •	Buffer, Rubber	4
33	800125	• •	Axle, PTO Mount	4
34	800128	• •	Plate, PTO Axle Mount	4
35	801684	• •	Assembly, 4/4CC Gear Pump	1
36	800061	• • •	O-Ring, Gear Pump	1
37	W-105650	• •	Assembly, Gear Pump (See Group 40, Figure 02 for DET)	1
38	801796	• •	Assembly, Tube	1
39	W-105170	• •	Adapter, STR	1
40	801506	• •	Adapter, 90L	2
41	801526	• •	Adapter, STR	2
42	W-105169	• •	Adapter, 45	1
43	801873-011	• •	Adapter	1
44	801524	• •	Adapter, STR	1
45	801509	• •	Adapter, 90L	1
46	802242	• •	Assembly, PTO Gear Box (See Group 40, Figure 03 for DET)	1
47	801527	• •	Adapter, STR	1
48		• •	Banjo	1
49	801890-006	• •	Swivel, Tee	2
50	801876-005	• •	Adapter, STR	1
51	86264-002	• •	Flange, Split	1
52	W-105075	• •	Adapter, STR	1
53	801876-003	• •	Adapter	2
54	801057	• •	Manifold, Pump	2
55	801794	• •	Assembly, Tube	1
56	801795	• •	Assembly, Tube	1
57	W-105567	• •	Sensor, Thermal	1
58	801927	• •	Adapter, Thermal Sensor	1
59	801499	• •	Filter, A4VG125 Charge Pump	2
60	801500	• • •	Element, A4VG125 Charge Pump Filter	2

DASH (-) ITEM NOT ILLUSTRATED



GEAR PUMP ASSEMBLY

XXT 32
PARTS
GROUP 40
FIGURE 05
PAGE 01

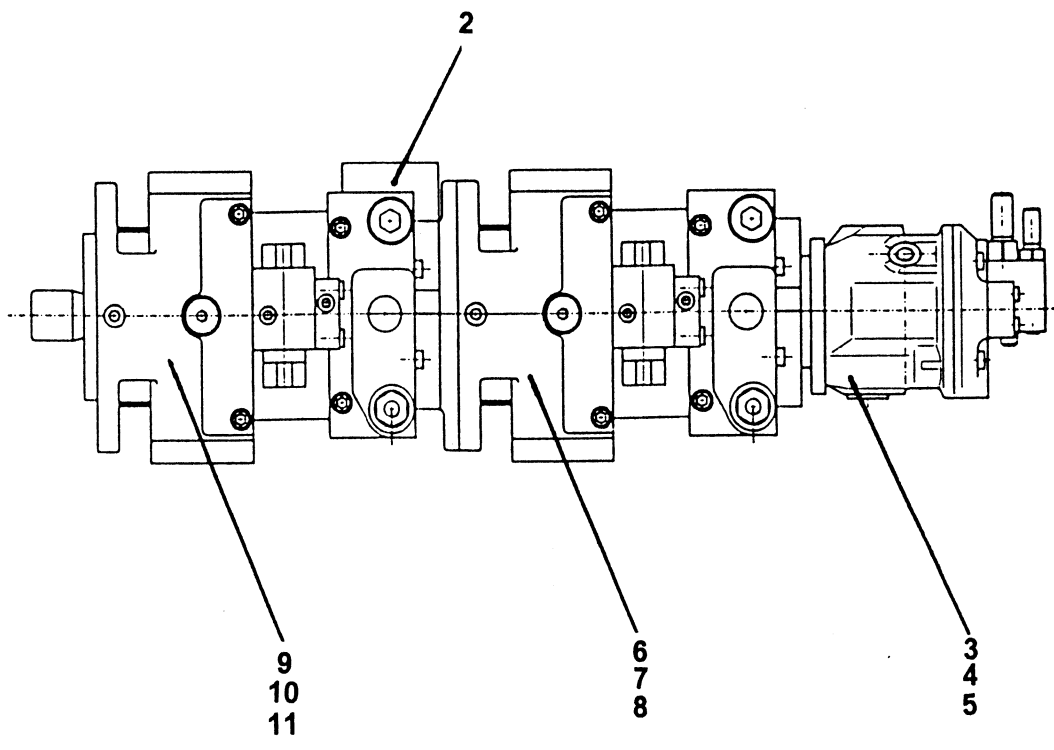



GEAR PUMP ASSEMBLY

XXT 32
PARTS
GROUP 40
FIGURE 05
PAGE 02

ITEM NO.	REED 'S PARTS NO.	DESCRIPTION					QTY
		1	2	3	4	5	
-1	W-105650	Assembly, Gear Pump (See Group 40, Figure 03 and 04 for NHA)					1
2	W-104949	• Valve, Flushing					1
3	W-105651	• Assembly, A10VO28 Gear Pump					1
4	W-105789	• • Kit, A10VO28 Gear Pump Seal					1
5	W-105001	• • Seal, Shaft					1
6	W-105592	• Assembly, A4VG125 Gear Pump					1
7	W-105787	• • Kit, A4VG125Gear Pump Seal					1
8	W-105788	• • Seal, Shaft					1
9	W-105591	• Assembly, A4VG125 Gear Pump					1
10	W-105785	• • Kit, A4VG125Gear Pump Seal					1
11	W-105786	• • Seal, Shaft					1

DASH (-) ITEM NOT ILLUSTRATED

ITEM NO.	REED'S PARTS NO.	DESCRIPTION					QTY
		1	2	3	4	5	
-1	802242	Assembly, PTO Gear Box (See Group 40, Figure 03 and 04 for NHA)					1
10	802160	• Cylinder, PTO Shift					1
20	802161	• Adapter, Shaft					1
25	802162	• Adapter, Shaft					1
30	802163	• Cap, Packing Ring					2
35	802164	• Flange, Mounting					1
40	802165	• Flange, Mounting					1
50	802166	• Cover					1
55	802167	• Flange, Mounting					1
60	802168	• Gear, Coupling					1
70	802169	• Gear					1
80	802170	• Gear					1
90	802171	• Gear					1
100	802172	• Shaft, Toothed					1
110	802173	• Shaft, Coupling					1
120	802174	• Shaft, Toothed					1
130	802175	• Shaft, Splined Hollow					1
140	802176	• Flange, Mounting					1
150	802177	• Coupling					1
160	802178	• Spacer					1
170	802179	• Adapter, Shaft					1
175	802180	• Ring, Running					2
180	802181	• Flange					2
190	802182	• Housing, Gearbox					1
200	802183	• Fork, Gear					10
210	802184	• Bearing, Ball					1
220	802185	• Bearing, Ball					1
230	802186	• Bearing, Ball					1
240	802187	• Bearing, Ball					2
245	802188	• Bearing, Ball					1
250	802189	• Bearing					1
260	802190	• Bearing, Roller					1
270	802191	• Bearing, Roller					1
280	802192	• Seal, Radial Oil					1
290	802193	• Seal, Radial Oil					1
300	802194	• Seal, Radial Oil					2
310	802195	• O-Ring					1
315	802196	• O-Ring					1
320	802197	• O-Ring					1
330	802198	• O-Ring					1
335	802199	• O-Ring					2

DASH (-) ITEM NOT ILLUSTRATED

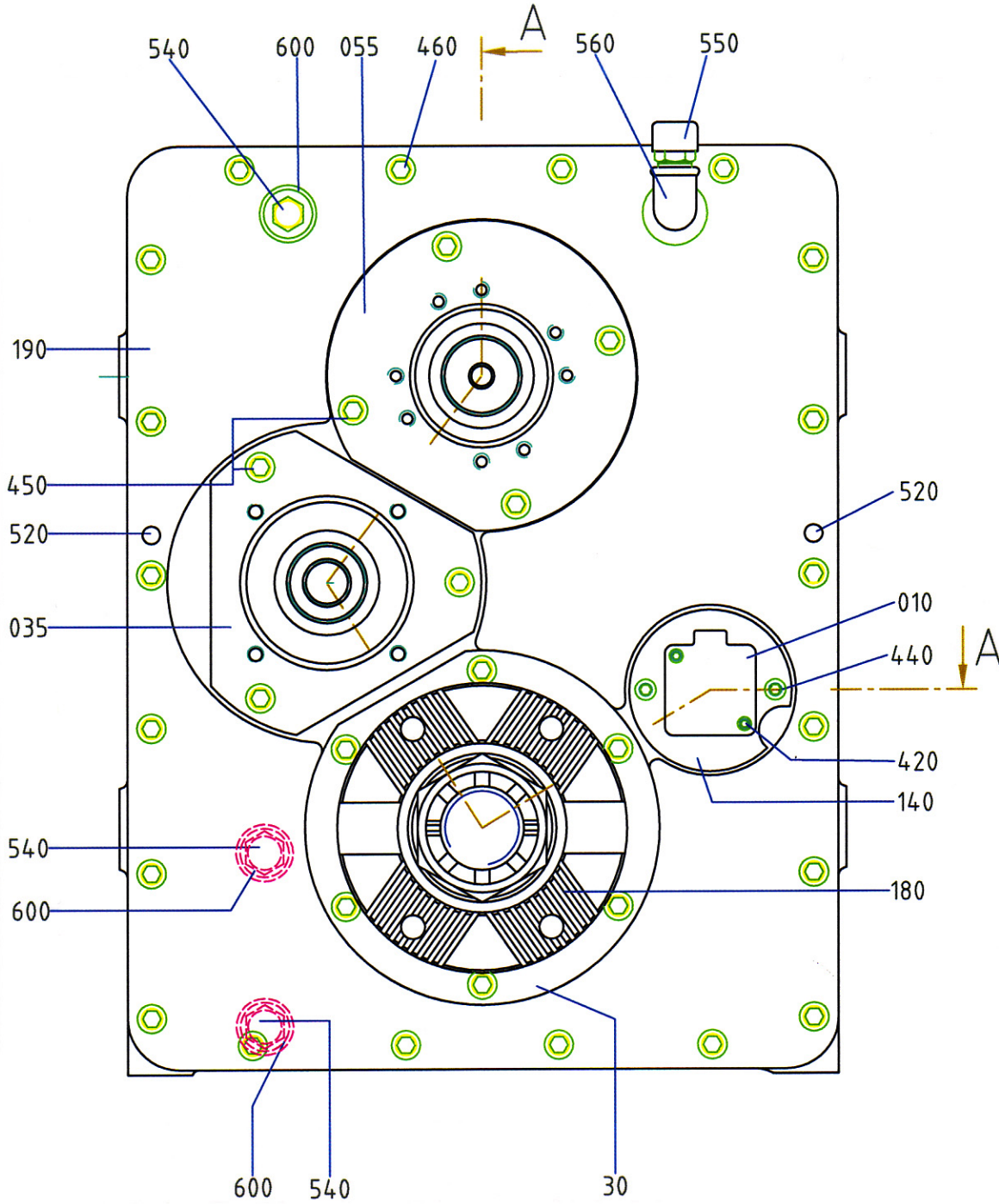

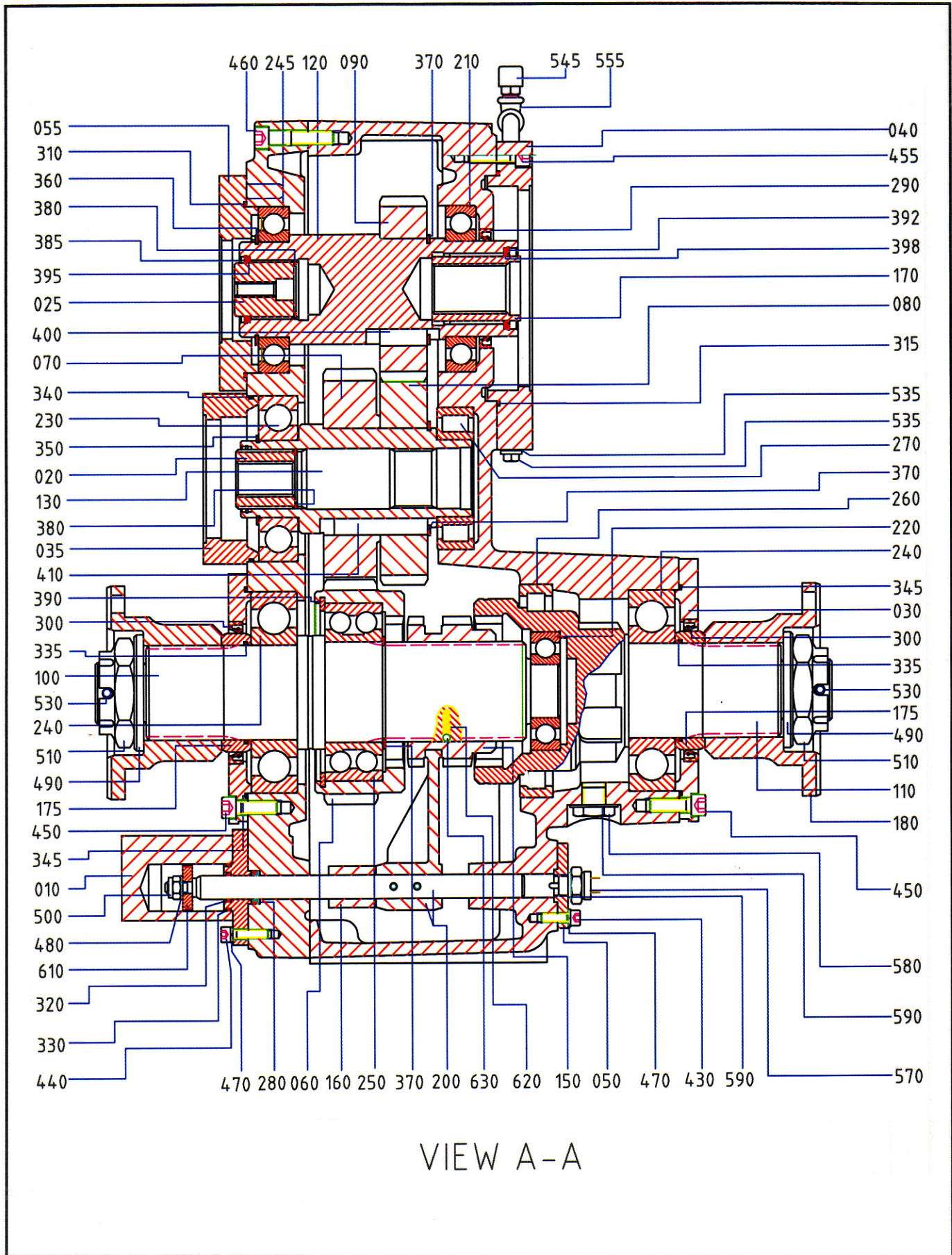

ITEM NO.	REED'S PARTS NO.	1 2 3 4 5	DESCRIPTION	QTY
340	802200		• O-Ring	1
345	802201		• O-Ring	2
350	802202		• Ring, Retaining	1
360	802203		• Ring, Retaining	1
370	802204		• Ring, Retaining	3
380	802205		• Ring, Retaining	2
385	802206		• Ring, Retaining	1
390	802207		• Ring, Retaining	1
392	802208		• Ring, Retaining	1
395	802209		• Disk, Support	1
398	802210		• Disk, Support	1
400	802211		• Key	2
410	802212		• Key	2
420	802213		• Screw, Socket Head Cap	2
430	802214		• Screw, Socket Head Cap	2
440	802215		• Screw, Socket Head Cap	2
450	802216		• Screw, Socket Head Cap	19
455	802217		• Screw, Socket Head Cap	8
460	802218		• Screw, Socket Head Cap	18
470	802219		• Washer, Lock	4
480	802220		• Disk	1
490	802221		• Disk	2
500	802222		• Nut, Hex	1
510	802223		• Nut, Castle	2
520	802224		• Pin	2
530	802225		• Pin, Spring	2
535	802226		• Plug, Hex Head	1
540	802227		• Plug, Hex Head	3
545	802228		• Filter, Vent	1
550	802229		• Filter, Vent	1
555	802230		• Elbow	2
560	802231		• Elbow	1
570	802232		• Switch, Limit	1
580	802233		• Plug, Hex Head	1
-585	802234		• Ring, Sealing	1
590	802235		• Ring, Sealing	2
600	802236		• Ring, Sealing	3
-605	802237		• Plug, Screw	2
610	802238		• Assembly, Piston	1
-615	802239		• Plug, Screw	1
620	802240		• Spring	1
630	802241		• Ball, 1/4 IN	1

DASH (-) ITEM NOT ILLUSTRATED

REED

**MODEL XXT 32 TRUCK MOUNTED
CONCRETE BOOM PUMP
ILLUSTRATED PARTS MANUAL**

**XXT 32
PARTS
GROUP 40
FIGURE 07
PAGE 01**

THIS PAGE INTENTIONALLY LEFT BLANK.

REED TRUCK MOUNTED CONCRETE BOOM PUMP MODEL **XXT 32** ILLUSTRATED PARTS MANUAL GROUP 50 CONTROLS INSTALLATION CONTAINS THE FOLLOWING FIGURES:

- FIGURE 00 TABLE OF CONTENTS
- FIGURE 01 CONTROLS INSTALLATION (BEF MAY 2000)
- FIGURE 02 CONTROLS INSTALLATION (AFT JUN 2000)
- FIGURE 03 CAB CONTROLS ASSEMBLY
- FIGURE 04 MAIN CONTROLS ASSEMBLY (BEF MAY 2000)
- FIGURE 05 MAIN CONTROLS ASSEMBLY (AFT JUN 2000)
- FIGURE 06 LH SIDE OUTRIGGER CONTROLS ASSEMBLY (BEF MAY 2000)
- FIGURE 07 LH SIDE OUTRIGGER CONTROLS ASSEMBLY (AFT JUN 2000)
- FIGURE 08 RH SIDE OUTRIGGER CONTROLS ASSEMBLY (BEF MAY 2000)
- FIGURE 09 RH SIDE OUTRIGGER CONTROLS ASSEMBLY (AFT JUN 2000)
- FIGURE 10 STATIONARY BOOM CONTROLS ASSEMBLY
- FIGURE 11 CABLED REMOTE CONTROL ASSEMBLY (BEF MAY 2000)
- FIGURE 12 CABLED REMOTE CONTROL ASSEMBLY (AFT JUN 2000)
- FIGURE 13 RADIO REMOTE CONTROL ASSEMBLY (BEF MAY 2000)
- FIGURE 14 RADIO REMOTE CONTROL ASSEMBLY (AFT JUN 2000)
- FIGURE 15 SHUNT ASSEMBLY

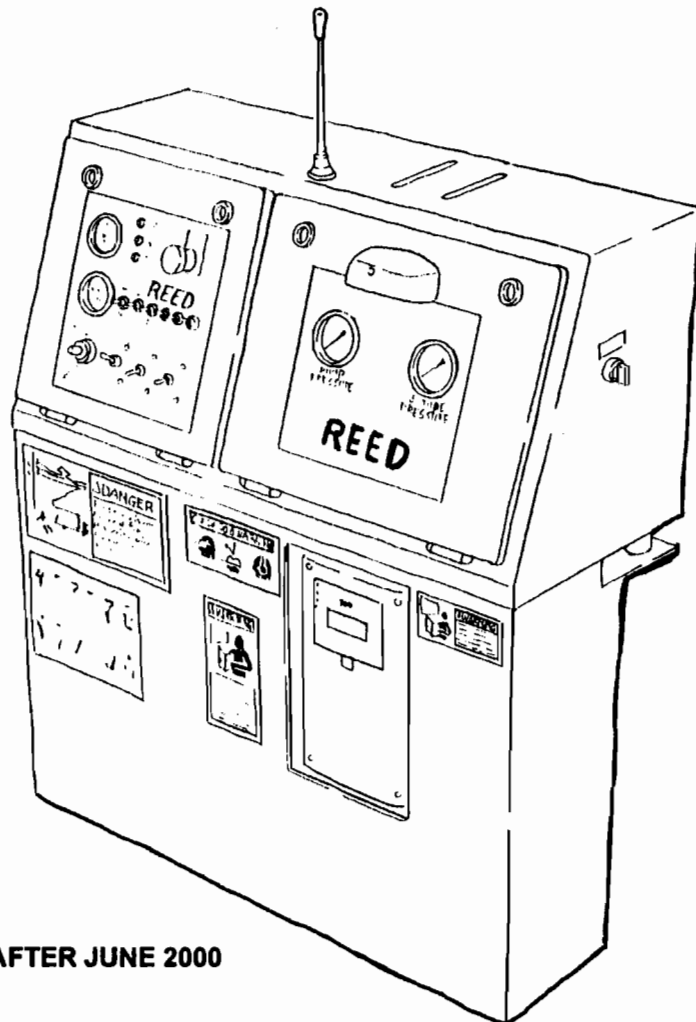

SHOWN MODEL: AFTER JUNE 2000

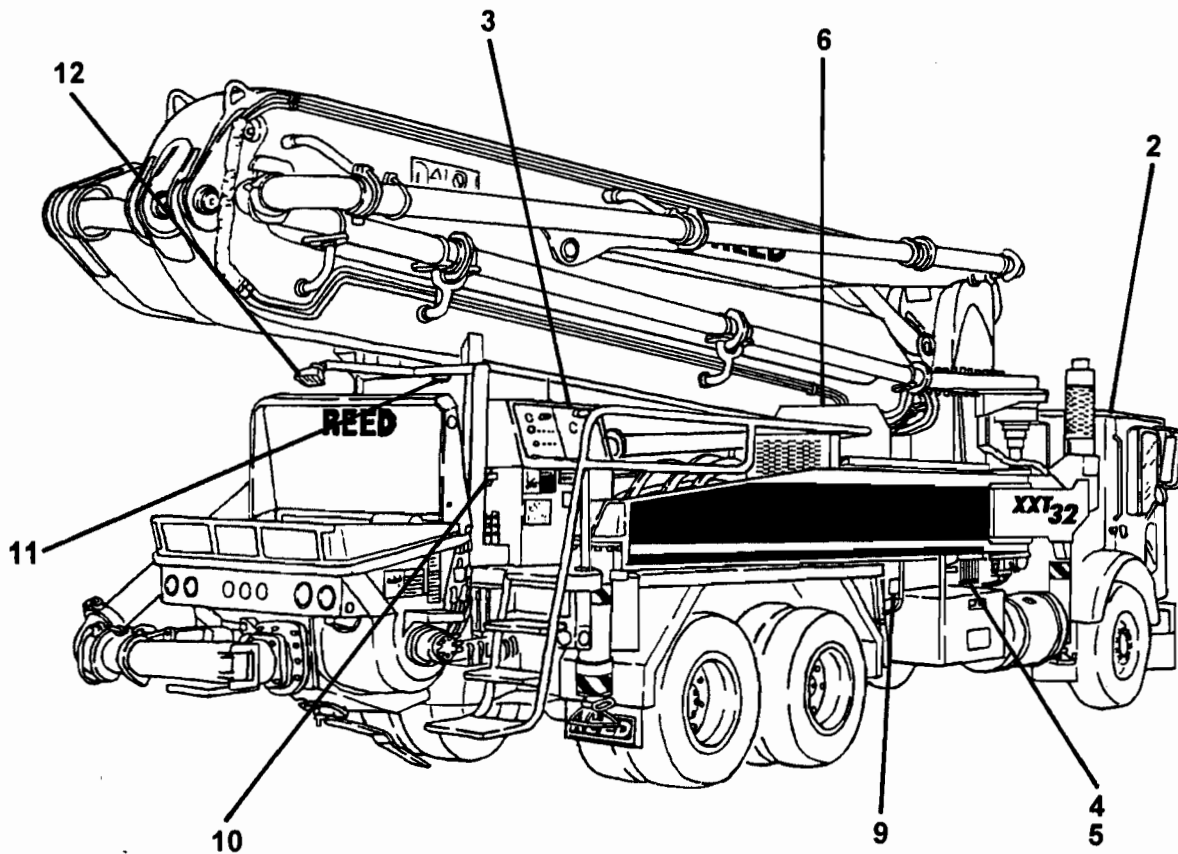

BEFORE MAY 2000

BEFORE MAY 2000

ITEM NO.	REED'S PARTS NO.	DESCRIPTION					QTY
		1	2	3	4	5	
-1	50-01	Installation, XXT 32 Controls (Bef May 2000) (See Group 10, Figure 01 for NHA)					Ref
2	800710	• Assembly, Cab Controls (See Group 50, Figure 03 for DET)					1
3	50-04	• Assembly, Main Controls (Bef May 2000) (See Group 50, Figure 04 for DET)					1
4	50-06	• Assembly, Driver (L. H.) Side Outrigger Controls (Bef May 2000) (See Group 50, Figure 06 for DET)					1
5	50-08	• Assembly, Passenger (R. H.) Side Outrigger Controls (Bef May 2000) (See Group 50, Figure 08 for DET)					1
6	50-10	• Assembly, Stationary Boom Controls (See Group 50, Figure 10 for DET)					1
-7	50-11	• Assembly, Cabled Remote Control (Bef May 2000) (See Group 50, Figure 11 for DET)					1
-8	W-104428	• Assembly, Radio Remote Control (Bef May 2000) (See Group 50, Figure 13 for DET)					1
9	C-VW00587	• Assembly, Shunt (See Group 50, Figure 15 for DET)					1
10	800347	• Horn, 12V					1
11	800072	• Switch, Limit					1
12	800095	• Light, Floor Work					1

DASH (-) ITEM NOT ILLUSTRATED



CONTROLS INSTALLATION (AFTER JUNE 2000)

XXT 32
PARTS
GROUP 50
FIGURE 02
PAGE 01

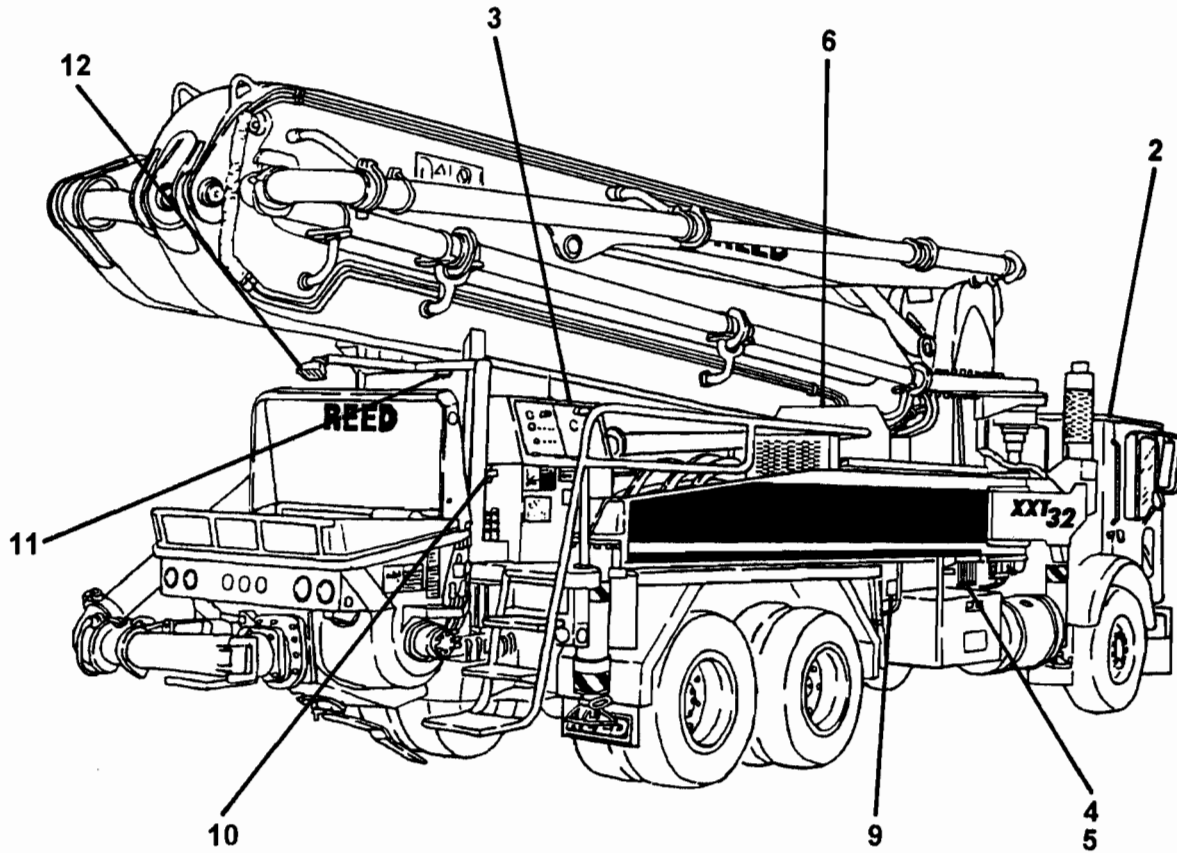

AFTER JUNE 2000

AFTER JUNE 2000

ITEM NO.	REED'S PARTS NO.	DESCRIPTION					QTY
		1	2	3	4	5	
-1	50-01	Installation, XXT 32 Controls (Aft Jun 2000) (See Group 10, Figure 01 for NHA)					Ref
2	800710	• Assembly, Cab Controls (See Group 50, Figure 02 for DET)					1
3	50-05	• Assembly, Main Controls (Aft Jun 2000) (See Group 50, Figure 05 for DET)					1
4	50-07	• Assembly, Driver (L. H.) Side Outrigger Controls (Aft Jun 2000) (See Group 50, Figure 07 for DET)					1
5	50-09	• Assembly, Passenger (R. H.) Side Outrigger Controls (Aft Jun 2000) (See Group 50, Figure 09 for DET)					1
6	C-DD103	• Assembly, Stationary Boom Controls (See Group 50, Figure 10 for DET)					1
-7	W-105565	• Assembly, Cabled Remote Control (Aft Jun 2000) (See Group 50, Figure 12 for DET)					1
-8	W-105566	• Assembly, Radio Remote Control (Aft Jun 2000) (See Group 50, Figure 14 for DET)					1
9	C-VW00587	• Assembly, Shunt (See Group 50, Figure 15 for DET)					1
10	800347	• Horn, 12V					1
11	800072	• Switch, Limit					1
12	800095	• Light, Floor Work					1

DASH (-) ITEM NOT ILLUSTRATED

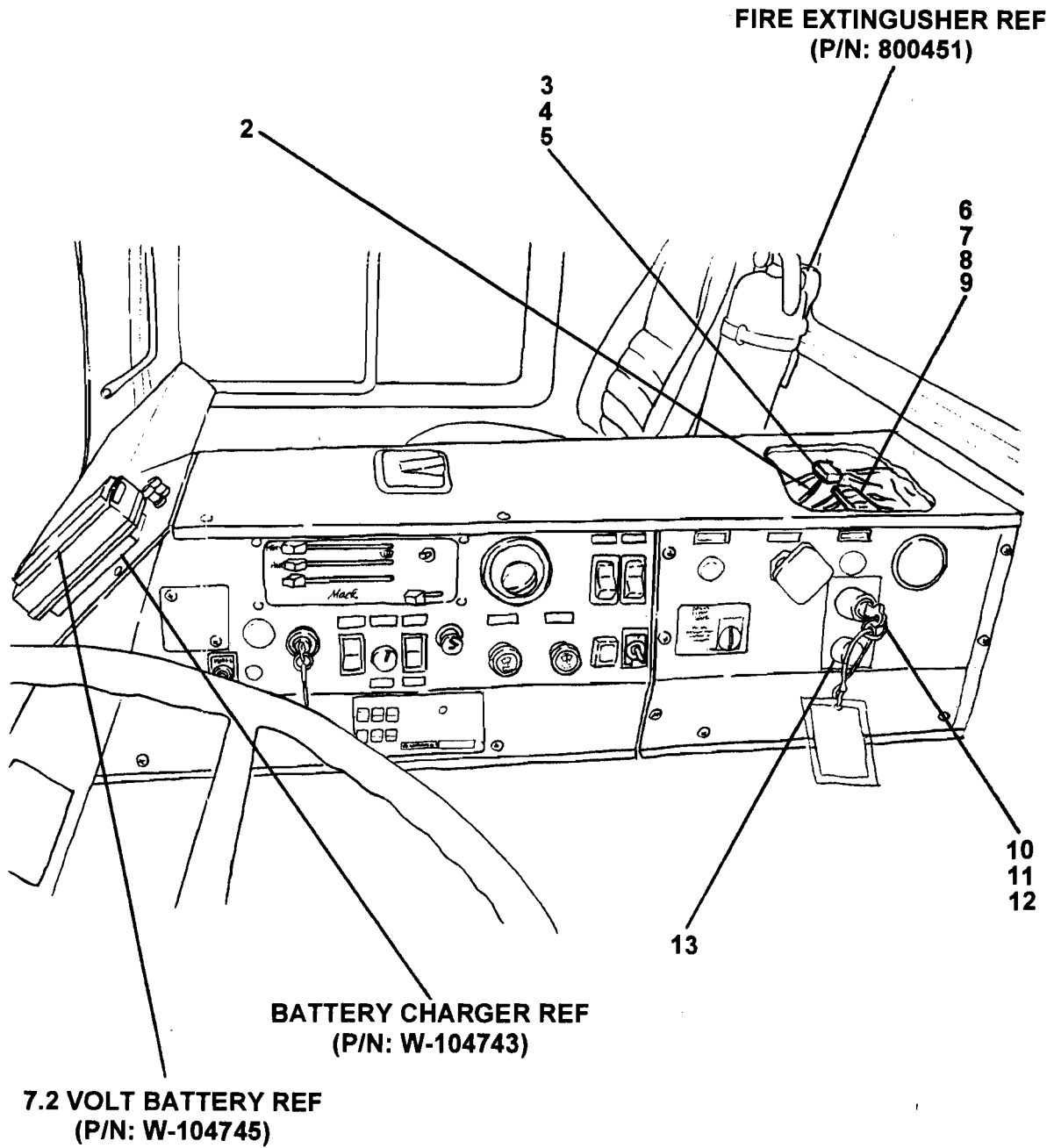

ITEM NO.	REED'S PARTS NO.	DESCRIPTION	QTY
		1 2 3 4 5	
-1	800710	Assembly, Cab Controls (See Group 50, Figure 01 and 02 for NHA)	1
2	10194	• Cable, 50 FT	1
3	800433	• Block, Fuse	1
4	800448	• Fuse, ATO 20	2
5	90392	• Fuse, ATO 5	1
6	72820	• Terminal	13
7	75654	• End, Barrier	1
8	72821	• Rail, Terminal	1
9	72824	• Jumper	3
10	800369	• Operator, Key	1
11	800370	• Block, Contact	1
12	800864	• Block, Contact	2
13	800414	• Light, Green Pilot	1
-14	800965	• Switch, Pressure (Located Near Engine)	1
-15	800909	• Switch, Clutch Limit (Located under Clutch Pedal)	1

DASH (-) ITEM NOT ILLUSTRATED



**MAIN CONTROLS ASSEMBLY
(BEFORE MAY 2000)**

**XXT 32
PARTS
GROUP 50
FIGURE 04
PAGE 01**

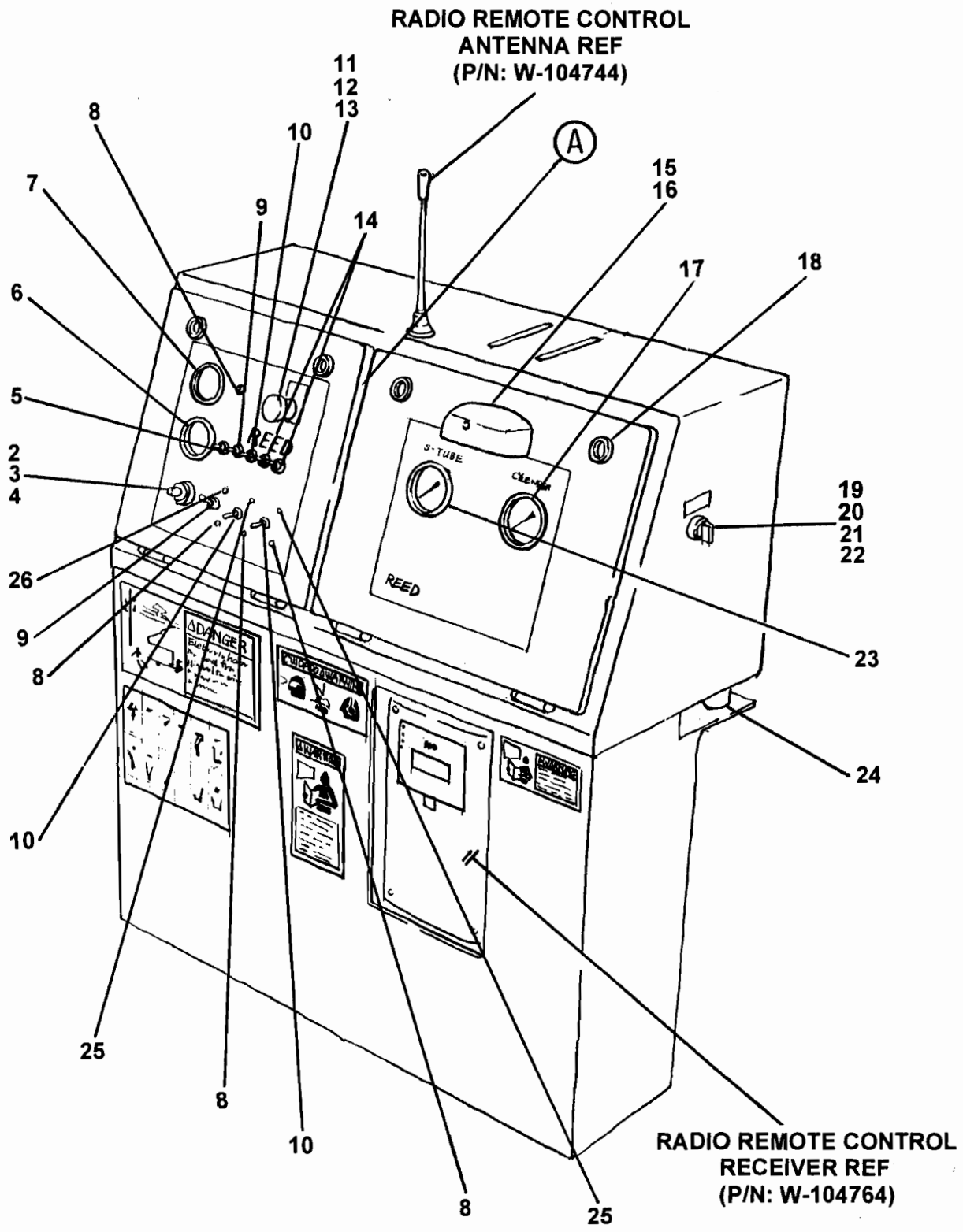

BEFORE MAY 2000

BEFORE MAY 2000

ITEM NO.	REED'S PARTS NO.	DESCRIPTION					QTY
		1	2	3	4	5	
-1	50-04	Assembly, Main Controls (Bef May 2000) (See Group 50, Figure 01 for NHA)					Ref
2		• Assembly, Volume Control					1
3	W-104103	• • Potentiometer					1
4	W-104104	• • Body, Mounting					1
5	W-103976	• Switch, RPM Toggle					1
6	W-104761	• Tachometer, 0-4000 RPM					1
7	W-101732	• Meter, Hour					1
8	W-104086	• Light, Green Indicator					4
9	W-104090	• Switch, Vibrator / Pump Rev Toggle					2
10	W-104089	• Switch, Light / S-Tube / Pump Rev Toggle					3
11	W-104079	• Button, Emergency Stop					1
12	W-101712	• Element, Emergency Stop Contact					1
13	W-102278	• Nameplate, Emergency Stop					1
14	W-104091	• Switch, Lube / Horn Toggle					1
15	W-101033	• Assembly, Light					1
16	W-104101	• • Bulb, Replacement					1
17	79831	• Gauge, 6000 PSI Pressure					1
18		• Lock, Twist					4
19	W-100968	• Switch, A & B Momentary Rotary					1
20	W-100969	• Contact, A & B Switch					3
21	W-103735	• Bridge, A & B Switch					1
22	W-100287	• Base, A & B Switch					1
23	70366	• Gauge, 3000 PSI Pressure					1
24		• Mount, Rubber					A/R
25	W-104088	• Light, Red Indicator					2
26	W-104087	• Light, Green Indicator					1

DASH (-) ITEM NOT ILLUSTRATED



MAIN CONTROLS ASSEMBLY (BEFORE MAY 2000)

XXT 32
PARTS
GROUP 50
FIGURE 04
PAGE 03

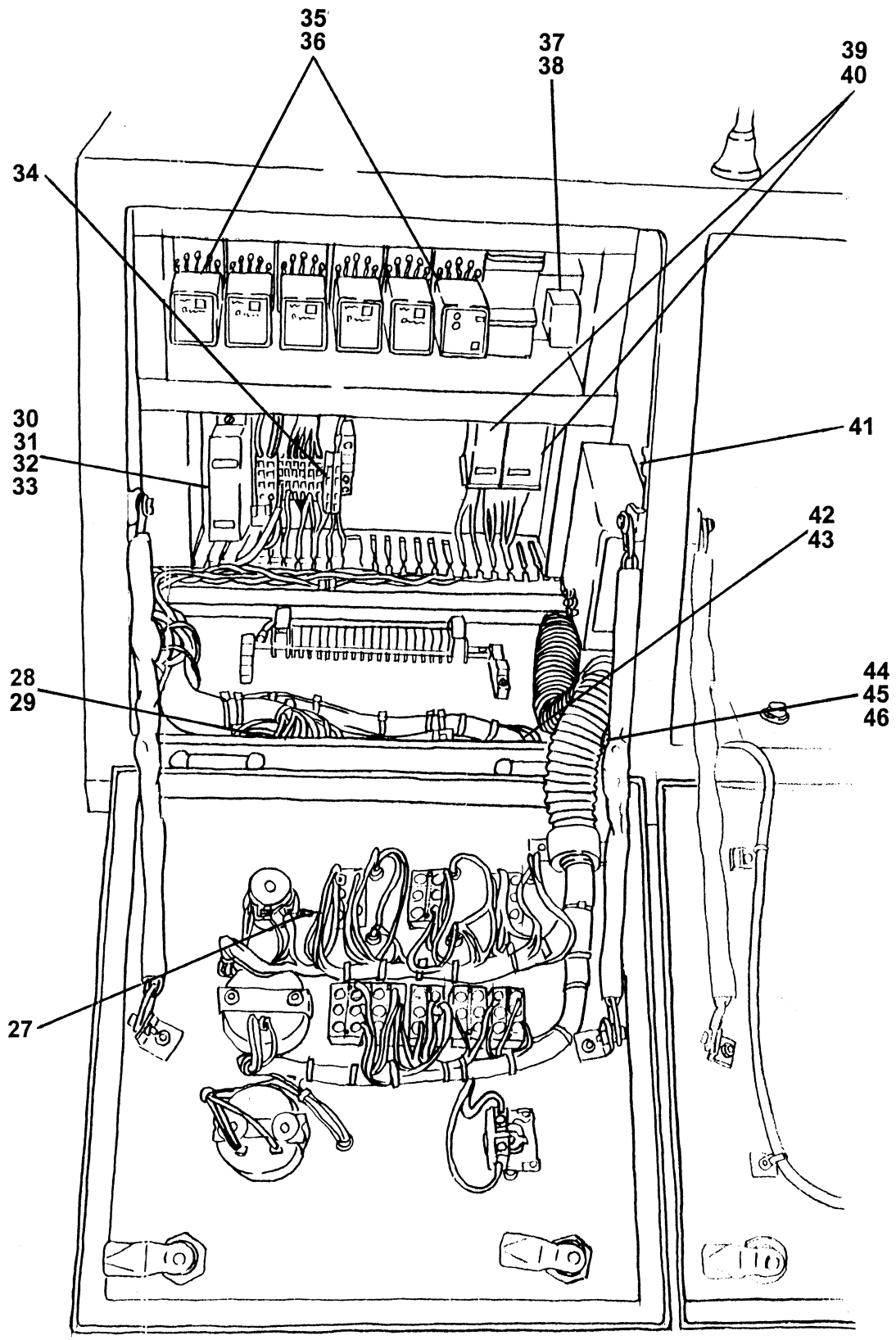

(A)

BEFORE MAY 2000

BEFORE MAY 2000

ITEM NO.	REED'S PARTS NO.	DESCRIPTION					QTY
		1	2	3	4	5	
27	W-104118	• Resistor, 100 OHM					1
28	W-100710	• Contact, 24 Pin Female (A)					1
29	W-101553	• Contact, 24 Pin Housing (A)					1
30	W-101577	• Holder, 8 Type Fuse					1
31	W-101922	• Fuse, 5 AMP					5
32	W-101921	• Fuse, 10 AMP					2
33	W-104096	• Fuse, 20 AMP					1
34	W-104185	• Diode					3
35	W-100178	• Base, Relay					6
36	W-104093	• Relay, Type 60.13					6
37	W-103974	• Base, Relay					1
38	W-105046	• Relay, Type 55.34					1
39	W-100986	• Base, Relay Bosch					2
40	W-104117	• Relay, Bosch					2
41	800461	• Box, Black					1
42	W-104022	• Contact, 16 Pin Female (B)					1
43	W-104097	• Contact, 16 Pin Housing (B)					1
44		• Contact, 8 Pin Female (C)					1
45		• Contact, 8 Pin Housing (C)					1
46	W-104773	• Contact, 8 Pin Male (C)					1

DASH (-) ITEM NOT ILLUSTRATED

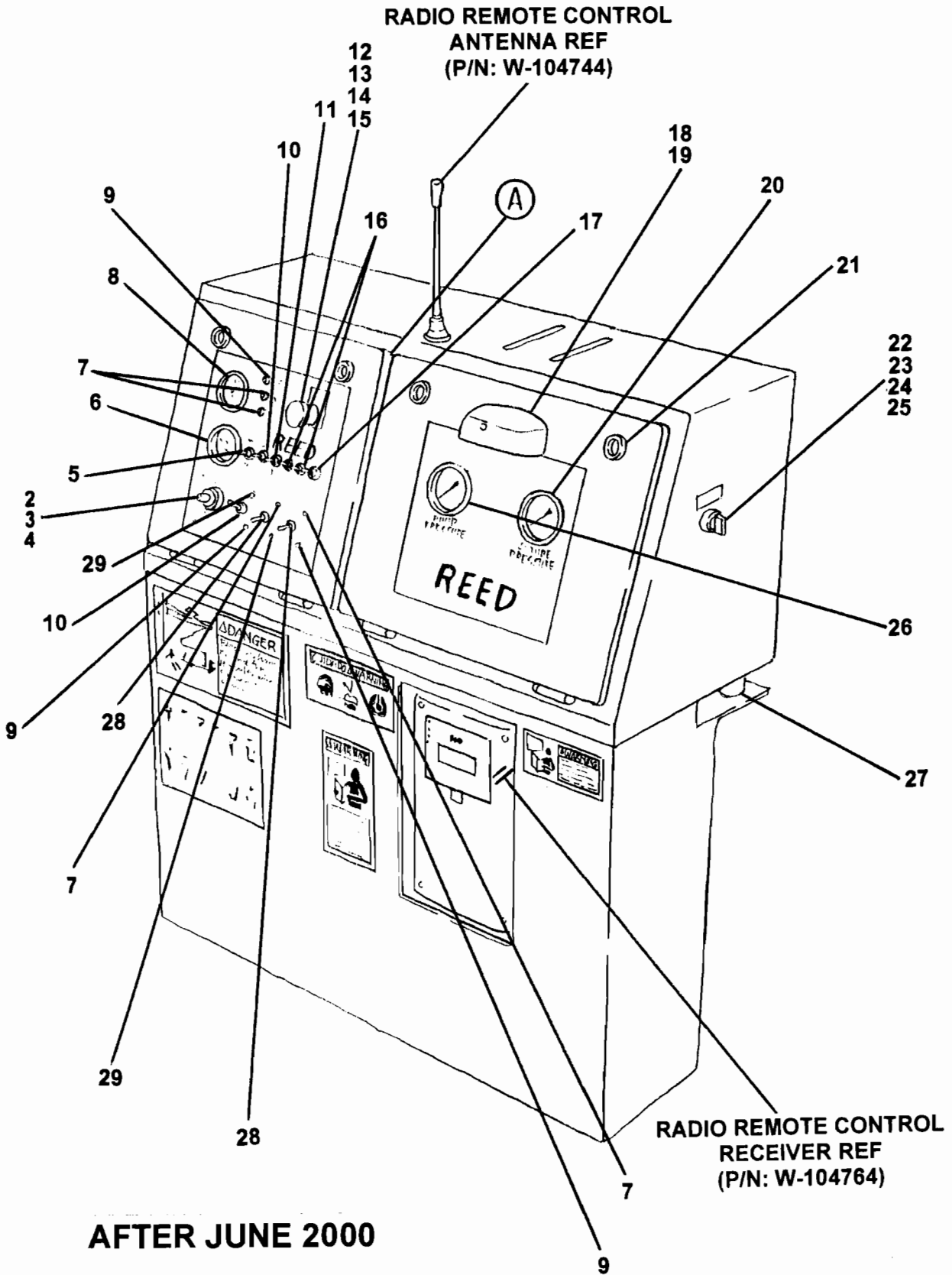



MAIN CONTROLS ASSEMBLY (AFTER JUNE 2000)

XXT 32
PARTS
GROUP 50
FIGURE 05
PAGE 02

AFTER JUNE 2000

ITEM NO.	REED'S PARTS NO.	DESCRIPTION					QTY
		1	2	3	4	5	
-1	50-05	Assembly, Main Controls (Aft Jun 2000) (See Group 50, Figure 02 for NHA)					Ref
2		• Assembly, Volume Control					1
3	W-104103	• • Potentiometer					1
4	W-104104	• • Body, Mounting					1
5	W-103976	• Switch, RPM Toggle					1
6	W-100900	• Meter, Hour					1
7	W-105811	• Light, Red Indicator					4
8	W-105823	• Thermometer					1
9	W-105813	• Light, Green Indicator					3
10	W-104090	• Switch, Vibrator / Pump Rev Toggle					2
11	W-104089	• Switch, Light / S-Tube / Pump Rev Toggle					3
12	W-105094	• Button, Emergency Stop					1
13	W-105095	• Element, Emergency Stop Contact					1
14	W-102278	• Nameplate, Emergency Stop					1
15	W-104083	• Light, Emergency					1
16	W-104091	• Switch, Lube / Horn Toggle					1
17	W-104089	• Switch, Lever					1
18	W-101033	• Assembly, Light					1
19	W-104101	• • Bulb, Replacement					1
20	70366	• Gauge, 3000 PSI Pressure					1
21		• Lock, Twist					4
22	W-100968	• Switch, A & B Momentary Rotary					1
23	W-100969	• Contact, A & B Switch					3
24	W-103735	• Bridge, A & B Switch					1
25	W-100287	• Base, A & B Switch					1
26	79831	• Gauge, 6000 PSI Pressure					1
27		• Mount, Rubber					A/R
28	72826	• Switch, On - On					1
29	W-105812	• Light, Yellow Indicator					2

DASH (-) ITEM NOT ILLUSTRATED

MAIN CONTROLS ASSEMBLY (AFTER JUNE 2000)

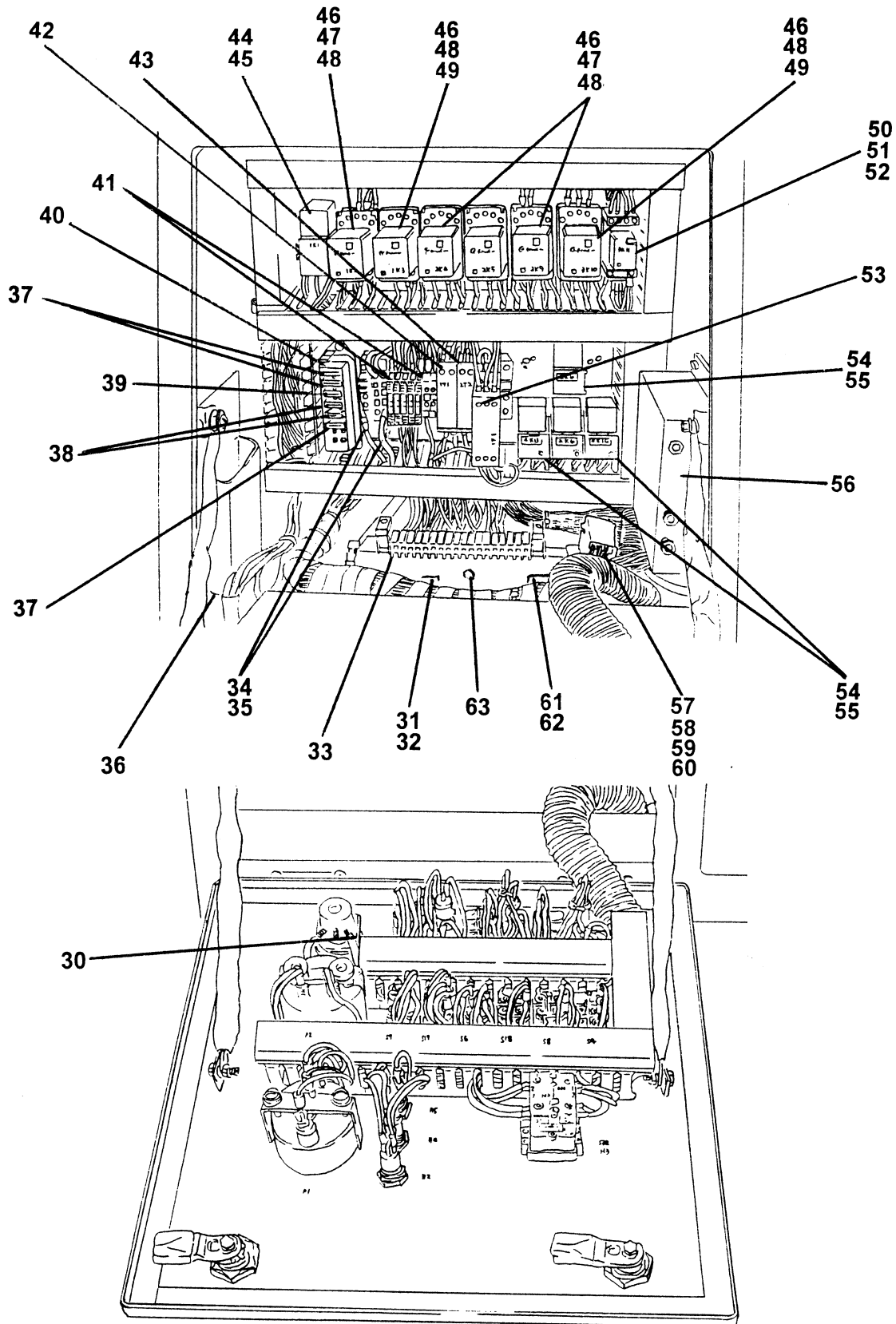

AFTER JUNE 2000

AFTER JUNE 2000

ITEM NO.	REED'S PARTS NO.	DESCRIPTION					QTY
		1	2	3	4	5	
30	W-104118	• Resistor, 100 OHM					1
31	W-100710	• Contact, 24 Pin Female (A)					1
32	W-101553	• Contact, 24 Pin Housing (A)					1
33	W-102577	• Block, Terminal					1
34	W-105817	• Clamp					2
35	W-105818	• Plate, End					2
36	W-104099	• Bag, Circuit Diagram					1
37	W-101921	• Fuse, 10 AMP					3
38	W-104096	• Fuse, 20 AMP					2
39	W-101922	• Fuse, 5 AMP					1
40	W-101577	• Holder, 8 Type Fuse					1
41	W-104185	• Diode					4
42	W-105331	• Relay, Time					1
43	W-105815	• Relay					1
44	W-105619	• Socket, Relay					1
45	W-104122	• Relay					1
46	W-104094	• Clip					6
47	W-100178	• Clip					4
48	W-104093	• Relay					6
49	W-104895	• Clip					2
50	W-103974	• Socket, Relay					1
51	W-105046	• Relay, Type 55.34					1
52	W-104860	• Clip					1
53	W-105814	• Element, Emergency Stop					1
54	W-100986	• Socket, Relay Bosch					4
55	W-104117	• Relay, Bosch					4
56	800461	• Box, Black					1
57	W-103693	• Contact, 8 Pin Female (C)					1
58	W-105816	• Contact, 8 Pin Housing (C)					1
59	W-103695	• Contact, Crimp (C)					1
60	W-103697	• Contact, Crimp (C)					1
61	W-104022	• Contact, 16 Pin Female (B)					1
62	W-104097	• Contact, 16 Pin Housing (B)					1
63	W-104669	• Condenser					1

DASH (-) ITEM NOT ILLUSTRATED

REED

**DRIVER SIDE (LEFT HAND)
OUTRIGGER CONTROLS ASSEMBLY
(BEFORE MAY 2000)**

**XXT 32
PARTS
GROUP 50
FIGURE 06
PAGE 01**

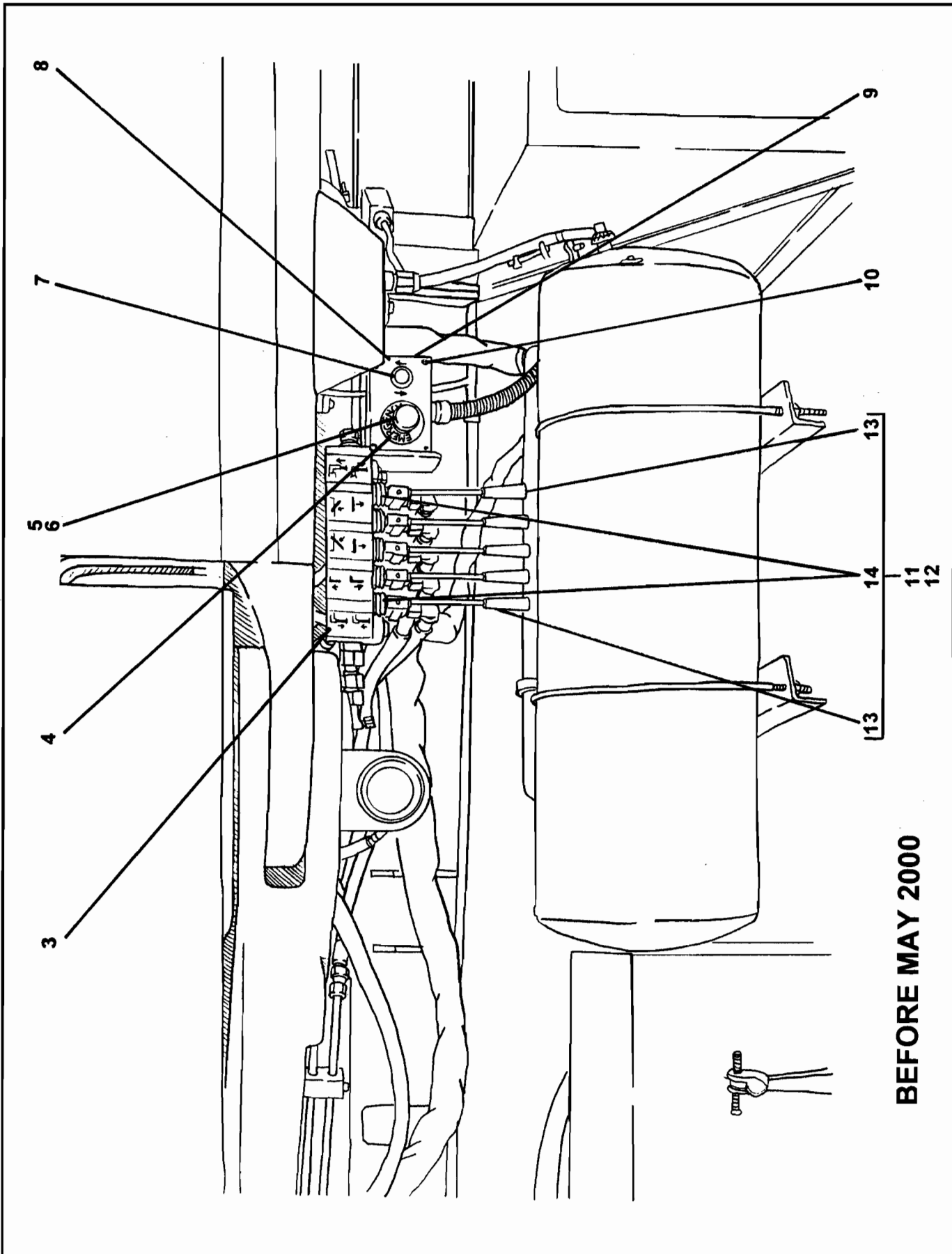

BEFORE MAY 2000

BEFORE MAY 2000

ITEM NO.	REED'S PARTS NO.	DESCRIPTION					QTY
		1	2	3	4	5	
-1	50-06	Assembly, Driver (L. H.) Side Outrigger Controls (Bef May 2000) (See Group 50, Figure 01 for NHA)					Ref
-2	800099	• Level, Bubble					1
3	C-9V112	• Decal, Left Side Stabilizers					1
4	W-102278	• Nameplate, Emergency					1
5	W-104079	• Button, Emergency Stop					1
6	W-101712	• Contact, Emergency Stop Element					1
7	W-103530	• Switch, Toggle					1
8		• Box, Non-Keyed Junction					1
9		• Decal, Non-Keyed Junction Box					1
10	W-103735	• Screw, Twist Lock Spring (attaching parts)					4
11	C-DD009	• Bank, Left Side Directional Valve					1
12		•• Lever					5
13		••• Lever, Knob					1
14		••• Boot, Rubber					1

DASH (-) ITEM NOT ILLUSTRATED



DRIVER SIDE (LEFT HAND)
OUTRIGGER CONTROLS ASSEMBLY
(AFTER JUNE 2000)

XXT 32
PARTS
GROUP 50
FIGURE 07
PAGE 01

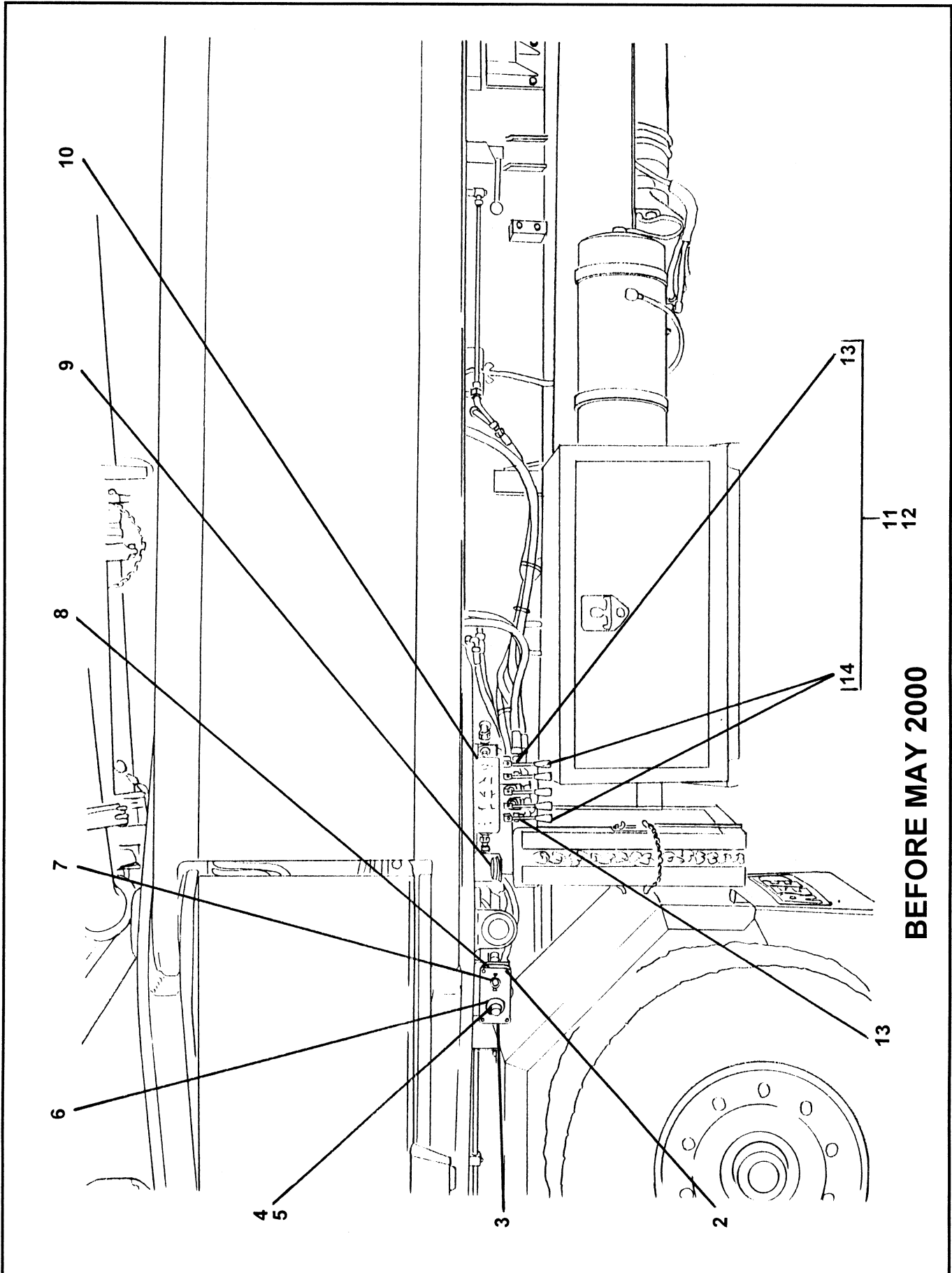

BEFORE MAY 2000

AFTER JUNE 2000

ITEM NO.	REED'S PARTS NO.	DESCRIPTION					QTY
		1	2	3	4	5	
-1	50-07	Assembly, Driver (L. H.) Side Outrigger Controls (Aft Jun 2000) (See Group 50, Figure 02 for NHA)					Ref
2	W-103735	• Screw, Twist Lock Spring (attaching parts)					4
3		• Box, Non-Keyed Junction					1
4	W-104079	• Button, Emergency Stop					1
5	W-101712	• Contact, Emergency Stop Element					1
6	W-102278	• Nameplate, Emergency					1
7	W-100569	• Button, Push Operation					1
8		• Decal, Non-Keyed Junction Box					1
9	800099	• Level, Bubble					1
10	C-9V112	• Decal, Left Side Stabilizers					1
11	C-DD009	• Bank, Left Side Directional Valve					1
12		• • Lever					5
13		• • • Lever, Knob					1
14		• • • Boot, Rubber					1

DASH (-) ITEM NOT ILLUSTRATED



PASSENGER SIDE (RIGHT HAND)
OUTRIGGER CONTROLS ASSEMBLY
(BEFORE MAY 2000)

XXT 32
PARTS
GROUP 50
FIGURE 08
PAGE 01

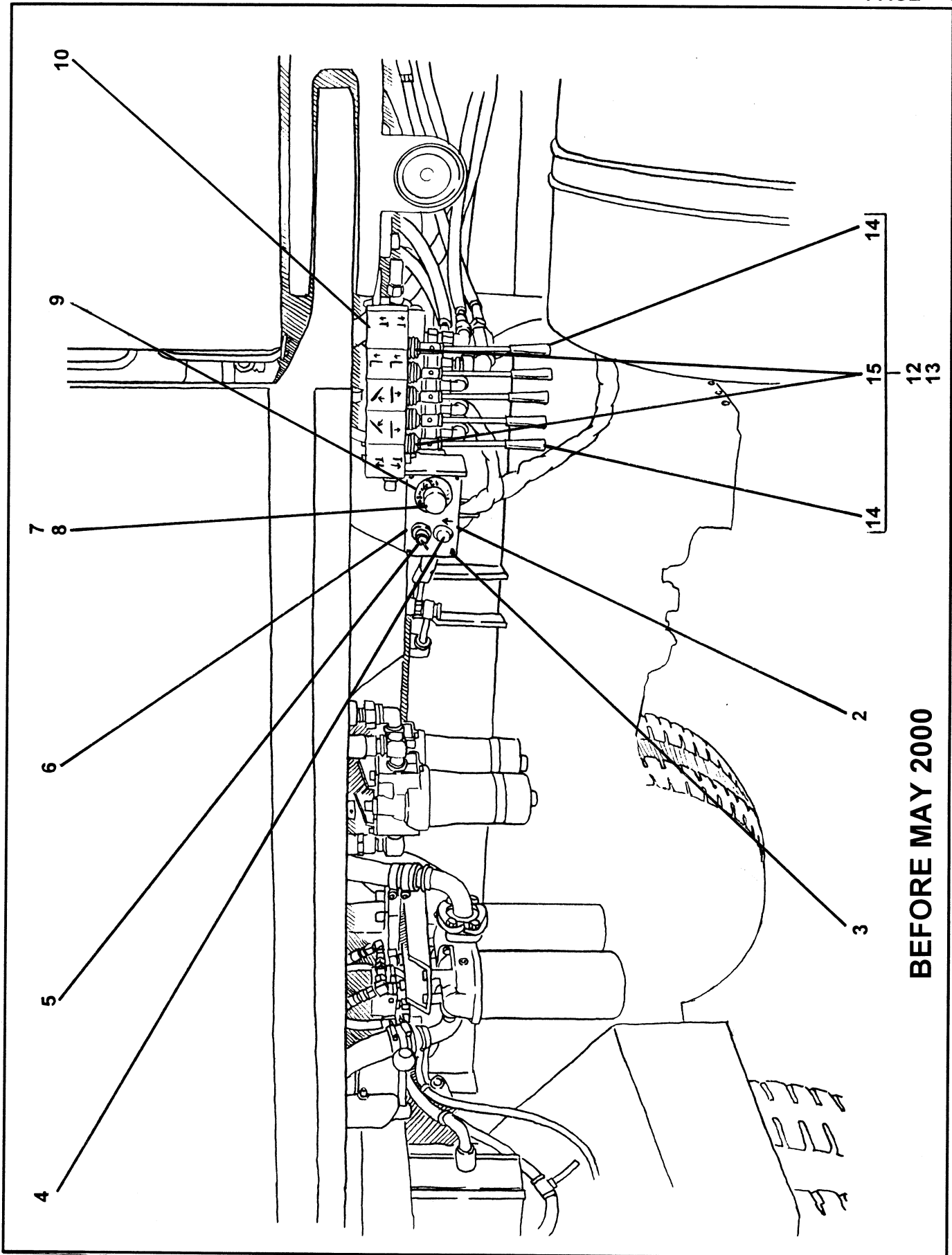

BEFORE MAY 2000



**PASSENGER SIDE (RIGHT HAND)
OUTRIGGER CONTROLS ASSEMBLY
(BEFORE MAY 2000)**

**XXT 32
PARTS
GROUP 50
FIGURE 08
PAGE 02**

BEFORE MAY 2000

ITEM NO.	REED'S PARTS NO.	DESCRIPTION					QTY
		1	2	3	4	5	
-1	50-08	Assembly, Passenger (R. H.) Side Outrigger Controls (Bef May 2000) (See Group 50, Figure 01 for NHA)					Ref
2		• Box, Keyed Junction					1
3	W-103735	• Screw, Twist Lock Spring (attaching parts)					4
4	W-103530	• Switch, Toggle					1
5	C-WW00190	• Switch, Key					1
6		• Decal, Keyed Junction Box					1
7	W-104079	• Button, Emergency Stop					1
8	W-101712	• Contact, Emergency Stop Element					1
9	W-102278	• Nameplate, Emergency					1
10	C-9V111	• Decal, Right Side Stabilizers					1
-11	800099	• Level, Bubble					1
12	C-DD009	• Bank, Right Side Directional Valve					1
13		• • Lever					5
14		• • • Lever, Knob					1
15		• • • Boot, Rubber					1

DASH (-) ITEM NOT ILLUSTRATED

PASSENGER SIDE (RIGHT HAND) OUTRIGGER CONTROLS ASSEMBLY (AFTER JUNE 2000)

XXT 32
PARTS
GROUP 50
FIGURE 09
PAGE 01

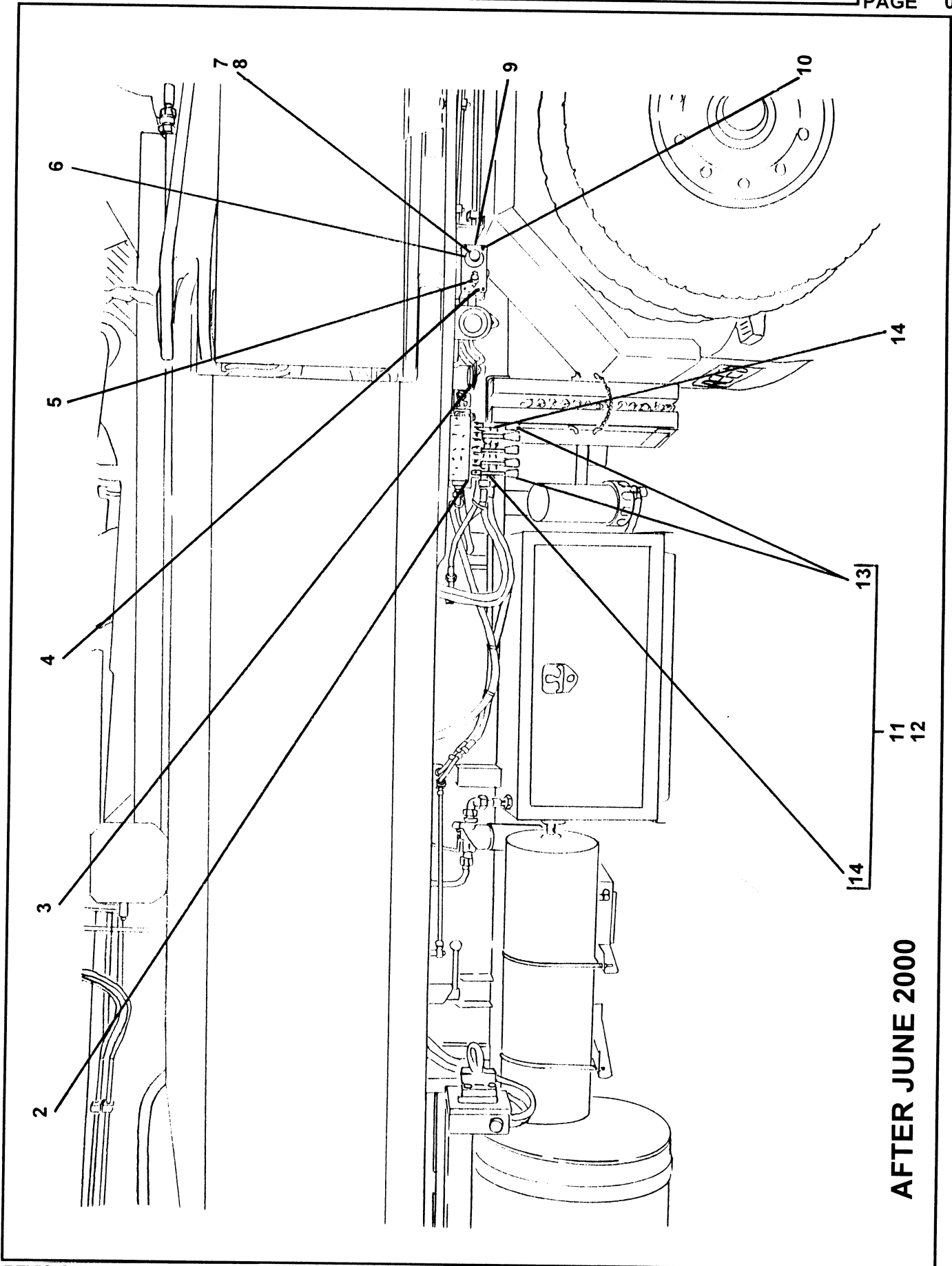

AFTER JUNE 2000

AFTER JUNE 2000

ITEM NO.	REED'S PARTS NO.	DESCRIPTION					QTY
		1	2	3	4	5	
-1	50-05	Assembly, Passenger (R. H.) Side Outrigger Controls (See Group 50, Figure 01 for NHA)					Ref
2	C-9V111	• Decal, Right Side Stabilizers					1
3	800099	• Level, Bubble					1
4		• Decal, Keyed Junction Box					1
5	W-100569	• Button, Push Operation					1
6	W-102278	• Nameplate, Emergency					1
7	W-104079	• Button, Emergency Stop					1
8	W-101712	• Contact, Emergency Stop Element					1
9		• Box, Keyed Junction					1
10	W-103735	• Screw, Twist Lock Spring (attaching parts)					4
11	C-DD009	• Bank, Right Side Directional Valve					1
12		• • Lever					5
13		• • • Lever, Knob					1
14		• • • Boot, Rubber					1

DASH (-) ITEM NOT ILLUSTRATED

STATIONARY BOOM CONTROLS ASSEMBLY

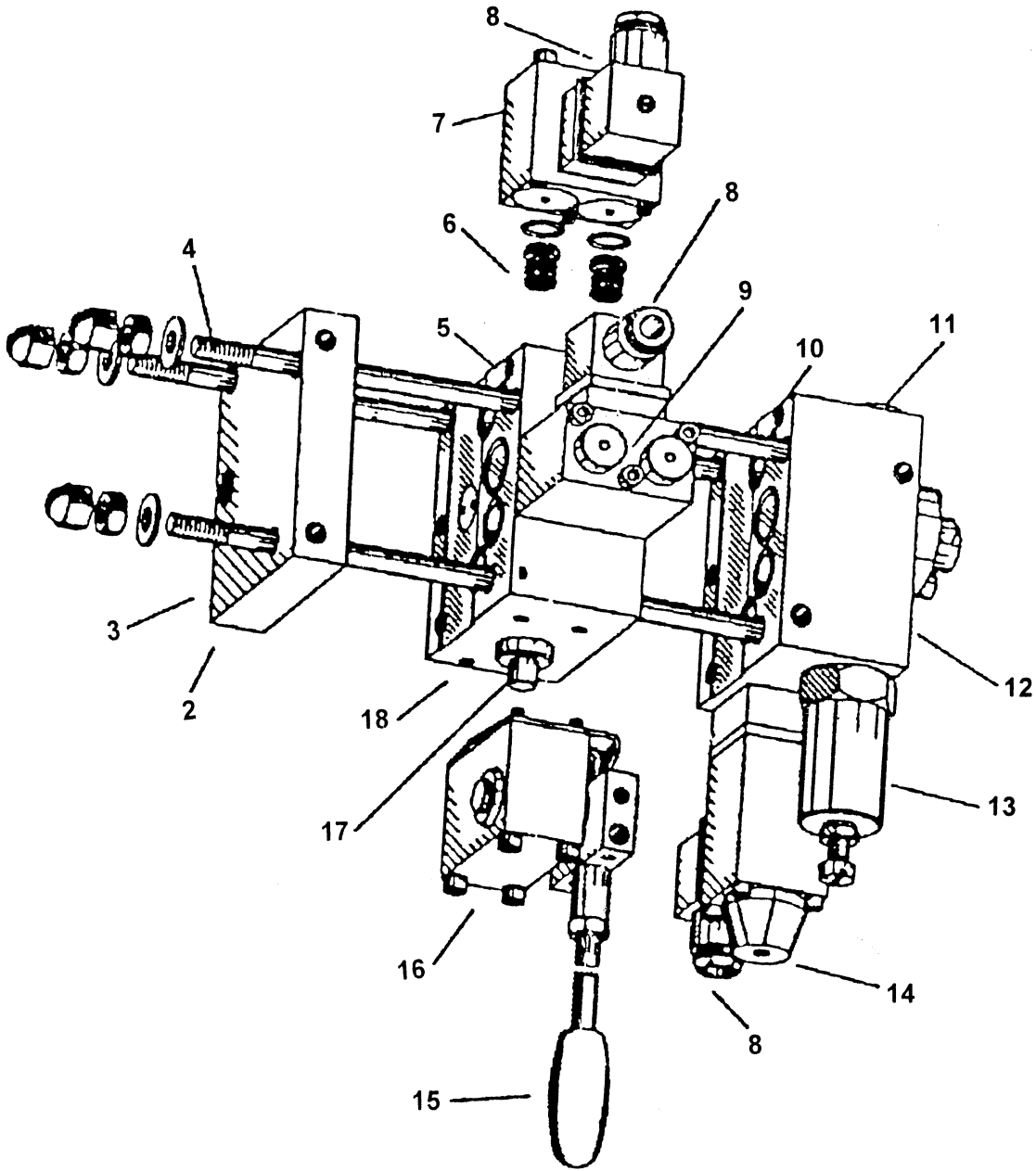

ITEM NO.	REED'S PARTS NO.	DESCRIPTION					QTY
		1	2	3	4	5	
-1	C-DD103	Assembly, Stationary Boom Controls (See Group 50, Figure 01 and 02 for NHA)					Ref
2		• Plate, End					1
3		• Valve, Check					1
4		• Set, Tension Rod					1
5		• Kit, Valve Section Seal					6
6		• Valve, Press Reducing					6
7		• Solenoid, Actuation					6
8		• Plug, Solenoid					13
9		• Solenoid, Function					6
10		• Kit, Connection Block Seal					1
11		• Valve, Pilot Press Reducing					1
12		• Block, Connection					1
13		• Valve, Pressure Limiting					1
14		• Valve, Directional Seated					1
15		• Lever, Hand					6
16		• Housing, Actuation					6
17		• Spool					6
18		• Valve, Section					6
-19	C-4V120	• Decal, Control					1

DASH (-) ITEM NOT ILLUSTRATED

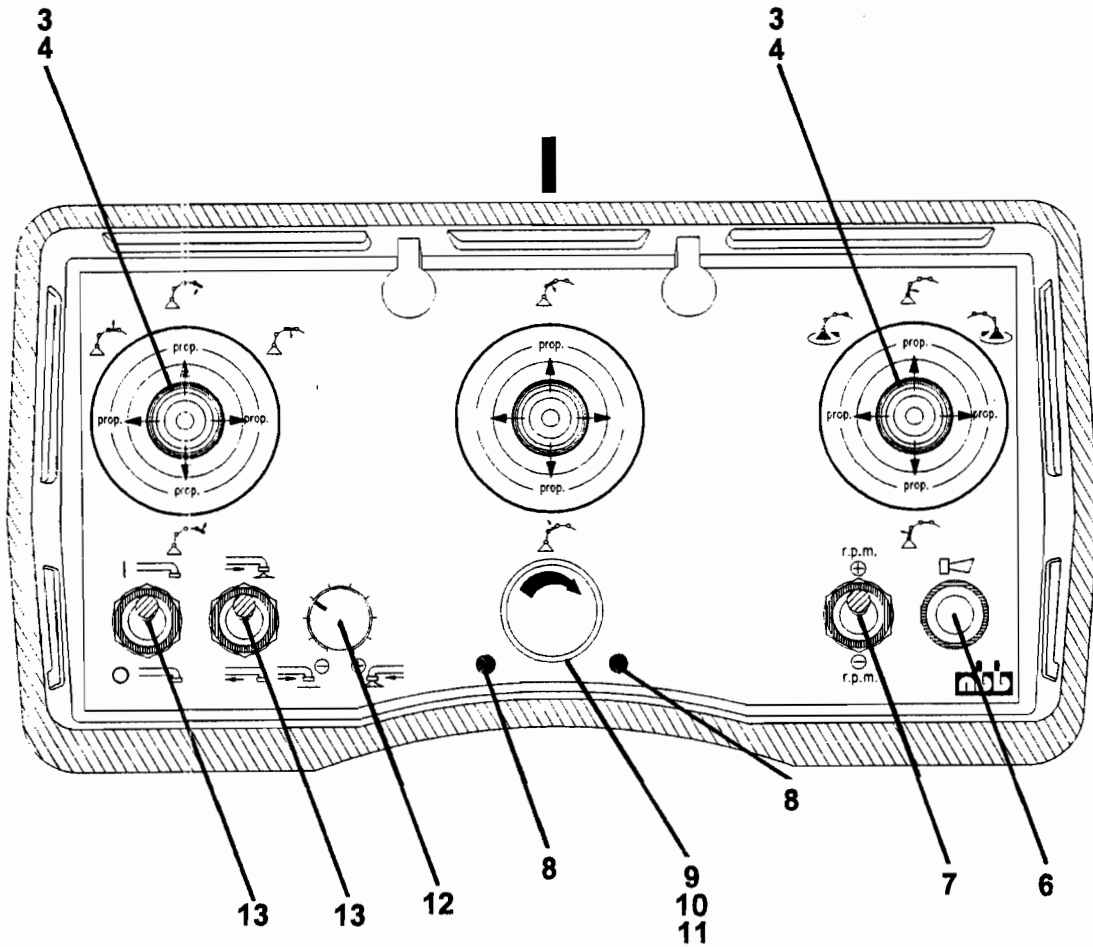

BEFORE MAY 2000

BEFORE MAY 2000

ITEM NO.	REED'S PARTS NO.	DESCRIPTION					QTY
		1	2	3	4	5	
-1	50-07	Assembly, Cabled Remote Control (Bef May 2000) (See Group 50, Figure 01 for NHA)					Ref
2	W-104429	• Sub-Assembly, Cabled Remote Control					1
3		• • Switch, Joy Stick Control					3
4		• • • Boot, Rubber					1
-5		• • Strap, Shoulder					1
6	3.740.1020	• • Switch, O – Mom Push Button					1
7	3.740.1017	• • Switch, O – Mom Toggle					1
8		• • Indicator, Light					2
9		• • Switch, Emergency Stop					1
10		• • • Knob, with Key					1
11		• • • Switch, Contact					1
12	3.980.1156	• • Potentiometer, with Knob					1
13	3.740.1018	• • Switch, On – O - On Toggle					2
14	W-104413	• Assembly, Cabled Remote Control Drum with 35m Cable					1
15	W-104477	• Assembly, Cabled					1
16		• • Plug, 16 Pin Male					1
17		• • Receptacle, 16 Pin Female					1

DASH (-) ITEM NOT ILLUSTRATED

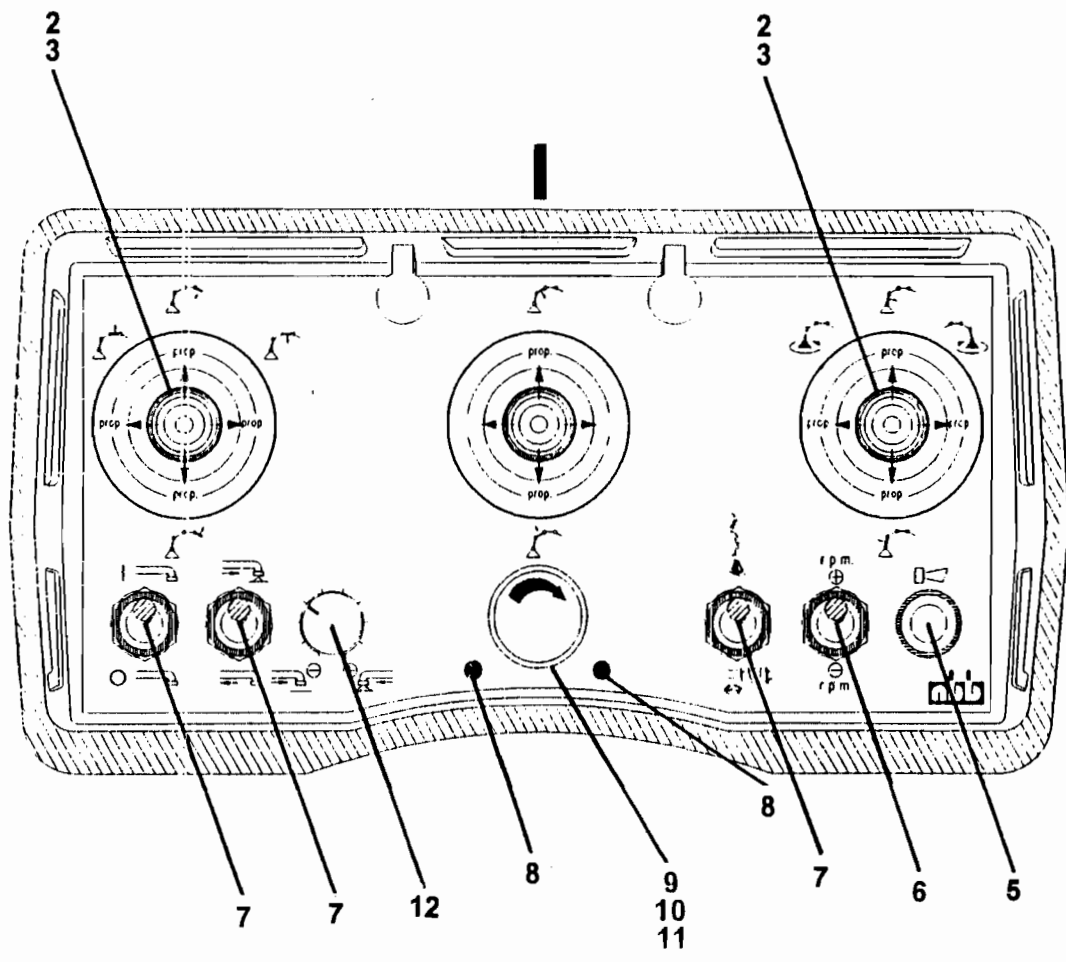

AFTER JUNE 2000

AFTER JUNE 2000

ITEM NO.	REED'S PARTS NO.	DESCRIPTION					QTY
		1	2	3	4	5	
-1	W-105565	Assembly, Cabled Remote Control (Aft Jun 2000) (See Group 50, Figure 02 for NHA)					Ref
2		• Switch, Joy Stick Control					3
3		• • Boot, Rubber					3
-4		• Strap, Shoulder					1
5	3.740.1020	• Switch, O - Mom Push Button					1
6	3.740.1017	• Switch, Mom - O - Mom Toggle					1
7	3.740.1018	• Switch, On - O - On Toggle					3
8		• • Indicator, Light					2
9		• • Switch, Emergency Stop					1
10		• • • Knob, with Key					1
11		• • • Switch, Contact					1
12	3.980.1156	• • Potentiometer, with Knob					1

DASH (-) ITEM NOT ILLUSTRATED

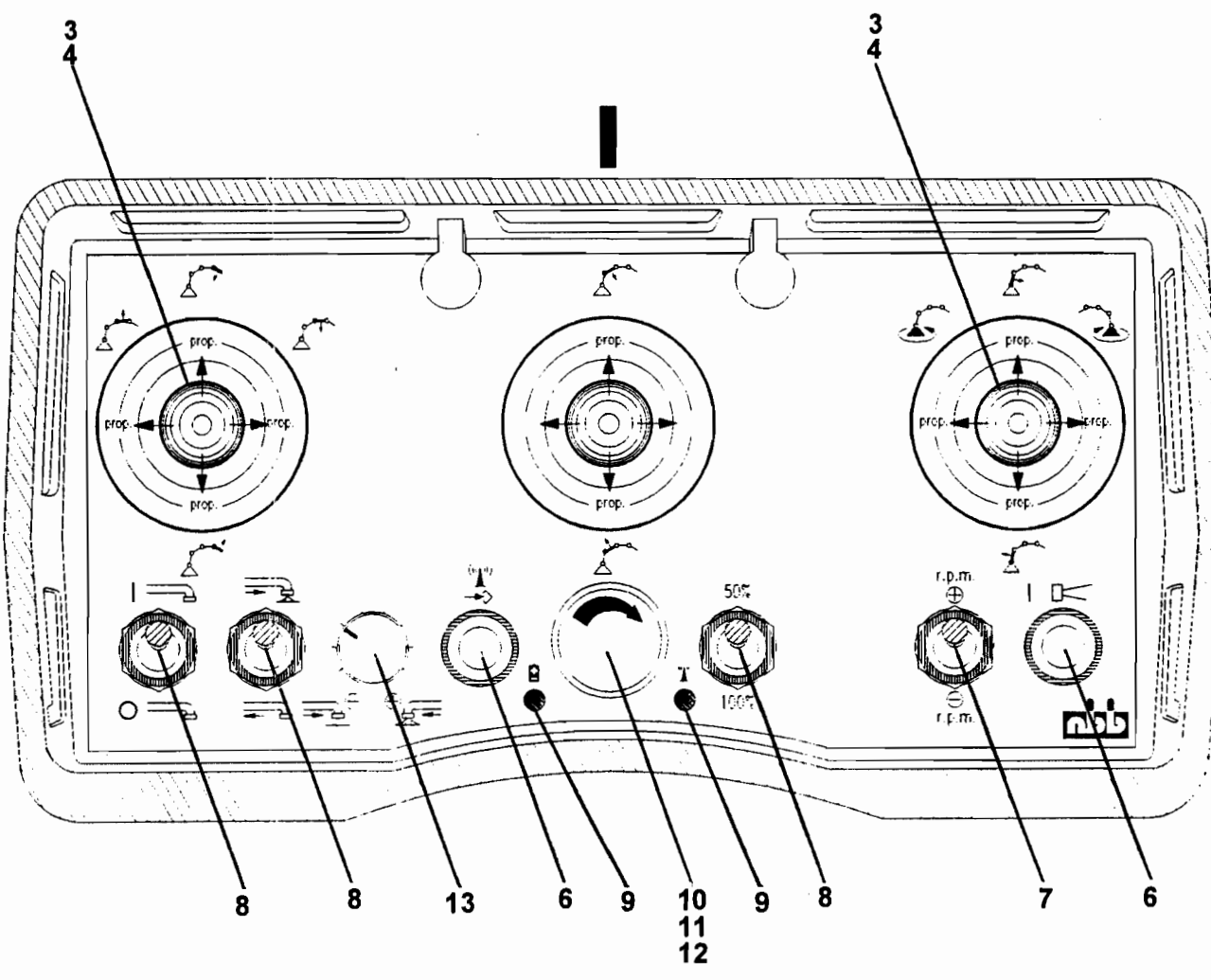

BEFORE MAY 2000

BEFORE MAY 2000

ITEM NO.	REED'S PARTS NO.	DESCRIPTION					QTY
		1	2	3	4	5	
-1	W-104428	Assembly, Radio Remote Control (Bef May 2000) (See Group 50, Figure 01 for NHA)					Ref
-2	W-104763	• Transmitter, Radio Remote Control					1
3		• • Switch, Joy Stick Control					3
4		• • • Boot, Rubber					1
-5		• • Strap, Shoulder					1
6	3.740.1020	• • Switch, O – Mom Push Button					1
7	3.740.1017	• • Switch, O – Mom Toggle					1
8	3.740.1018	• • Switch, On – O - On Toggle					3
9		• • Indicator, Light					2
10		• • Switch, Emergency Stop					1
11		• • • Knob, with Key					1
12		• • • Switch, Contact					1
13	3.980.1156	• • Potentiometer, with Knob					1
-14	W-104745	• Battery, 7.2V (See Group 50, Figure 03 for REF)					1
-15	W-104430	• Battery, Teach					1
-16	W-104764	• Receiver, Radio Remote Control (See Group 50, Figure 04 for REF)					1
-17		• • Indicator, Light					5
-18	W-104774	• Antenna, Radio Remote Control (See Group 50, Figure 04 for REF)					1
-19	W-104743	• Charger, Battery (See Group 50, Figure 03 for REF)					1

DASH (-) ITEM NOT ILLUSTRATED

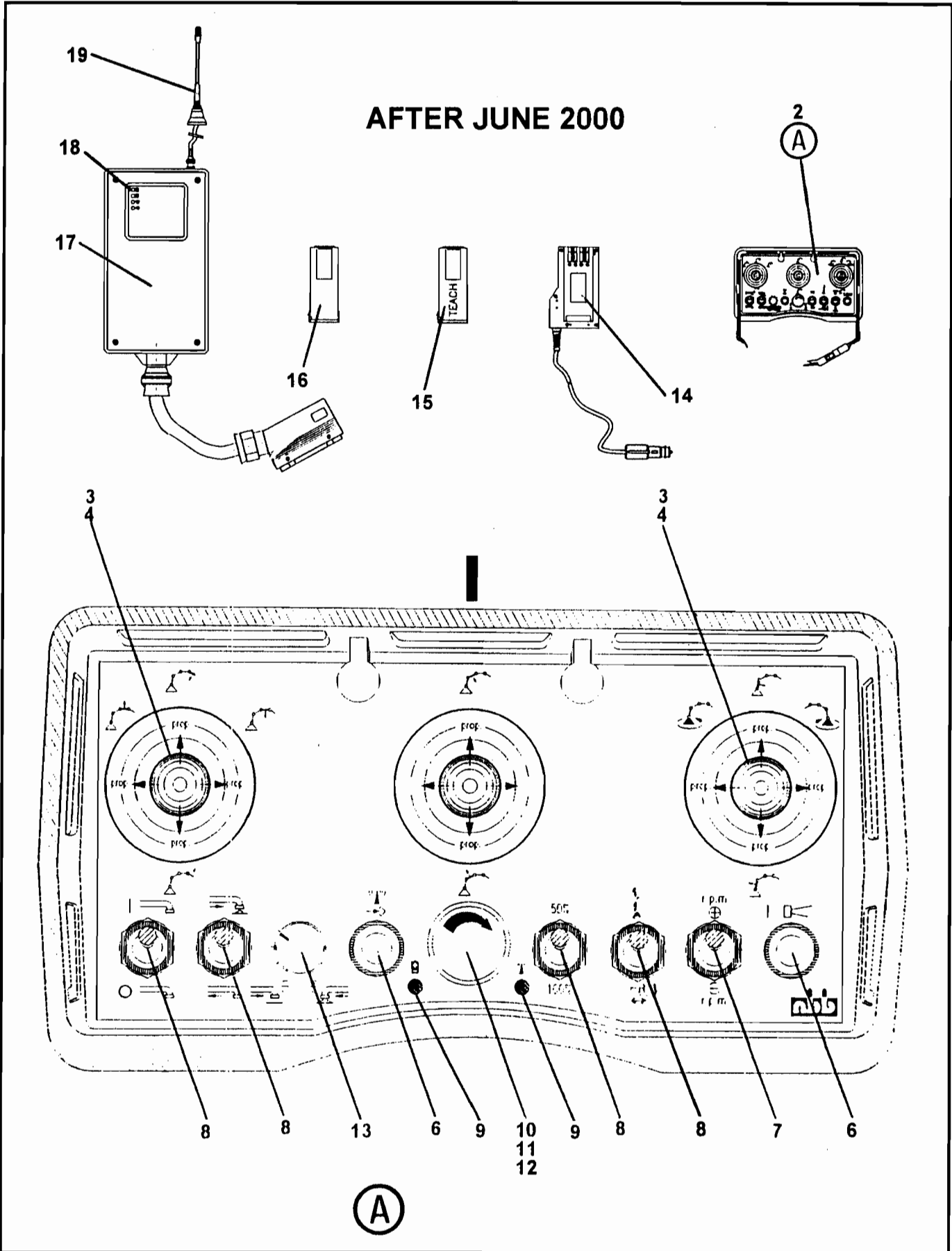

AFTER JUNE 2000

ITEM NO.	REED'S PARTS NO.	DESCRIPTION	QTY
-1	W-105566	Assembly, Radio Remote Control (Aft Jun 2000) (See Group 50, Figure 02 for NHA)	Ref
2	W-104763	• Transmitter, Radio Remote Control	1
3		• • Switch, Joy Stick Control	3
4		• • • Boot, Rubber	1
-5		• • Strap, Shoulder	1
6	3.740.1020	• • Switch, O – Mom Push Button	1
7	3.740.1017	• • Switch, O – Mom Toggle	1
8	3.740.1018	• • Switch, On – O - On Toggle	4
9		• • Indicator, Light	2
10		• • Switch, Emergency Stop	1
11		• • • Knob, with Key	1
12		• • • Switch, Contact	1
13	3.980.1156	• • Potentiometer, with Knob	1
14	W-104743	• Charger, Battery (See Group 50, Figure 03 for REF)	1
15	W-104430	• Battery, Teach	1
16	W-104745	• Battery, 7.2V (See Group 50, Figure 03 for REF)	1
17	W-104764	• Receiver, Radio Remote Control (See Group 50, Figure 05 for REF)	1
18		• • Indicator, Light	5
19	W-104774	• Antenna, Radio Remote Control (See Group 50, Figure 05 for REF)	1

DASH (-) ITEM NOT ILLUSTRATED

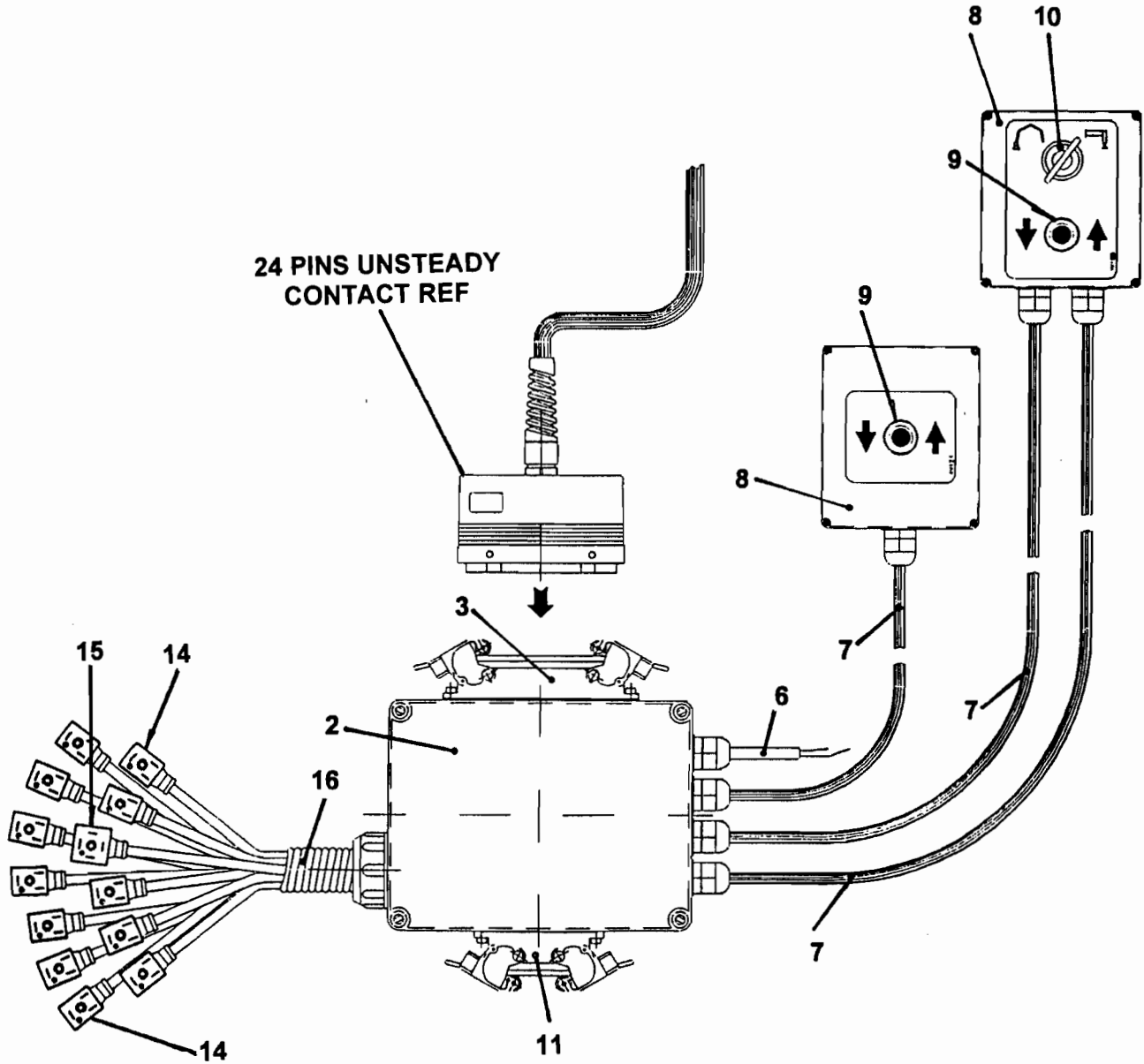

ITEM NO.	REED'S PARTS NO.	DESCRIPTION					QTY
		1	2	3	4	5	
-1	C-VW00587	Assembly, Shunt (See Group 50, Figure 01 and 02 for NHA)					Ref
2	C-WW00230	••	Box, Connector	214 X 162 X 92		1	
3		••	Plug, 24 Points Contact			1	
-4	C-WW00154	•••	Plug			1	
-5	C-WW00167	•••	Case, Plug			1	
6	C-WW00116	••	Cable, Electric	1.6 m		1	
7	C-WW00265	••	Cable, Electric	4 m		3	
8	C-ESC01	••	Box, Junction			2	
9	C-EI031	••	Switch			2	
10	C-WW00190	••	Switch, 2 Position Key			1	
11		••	Plug, 10 Points Auxiliary Contact			1	
-12	C-WW00011	•••	Plug			1	
-13	C-WW00037	•••	Case, Plug			1	
14	C-WW00065	••	Plug, Rectangular with Cable			12	
15	C-WW00175	••	Plug, Square with Electric Cable			1	
16	C-WW00100	••	Cable, 1.5 m Sheath			1	

DASH (-) ITEM NOT ILLUSTRATED



**MODEL XXT 32 TRUCK MOUNTED
CONCRETE BOOM PUMP
ILLUSTRATED PARTS MANUAL**

**XXT 32
PARTS
GROUP 50
FIGURE 16
PAGE 01**

THIS PAGE INTENTIONALLY LEFT BLANK.

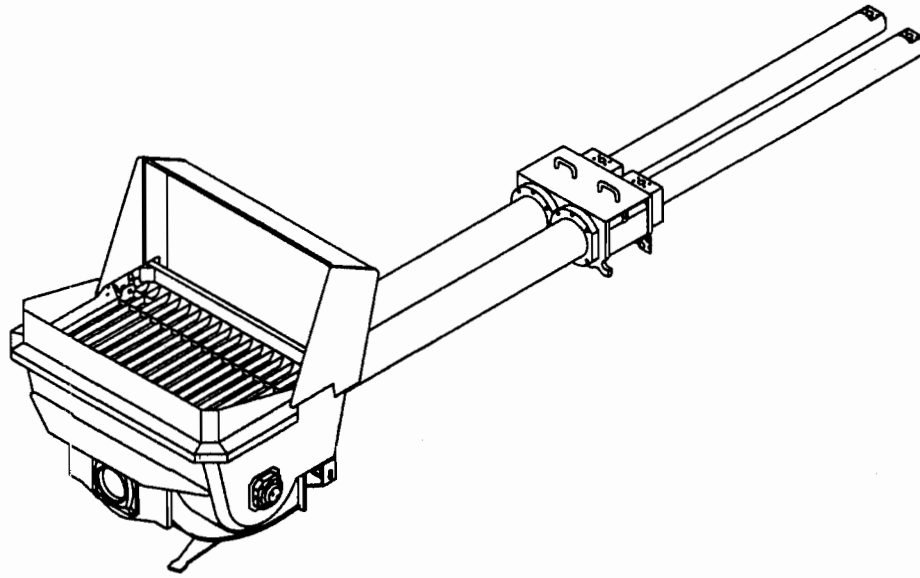

REED TRUCK MOUNTED CONCRETE BOOM PUMP MODEL **XXT 32**
ILLUSTRATED PARTS MANUAL GROUP 60 PUMPING TRAIN INSTALLATION
CONTAINS THE FOLLOWING FIGURES:

FIGURE 00	TABLE OF CONTENTS
FIGURE 01	PUMPING TRAIN INSTALLATION
FIGURE 02	SWING VALVE ASSEMBLY
FIGURE 03	TILTING DRIVE ASSEMBLY
FIGURE 04	TILTING CYLINDER ASSEMBLY
FIGURE 05	CONCRETE CYLINDER ASSEMBLY
FIGURE 06	WATER BOX ASSEMBLY
FIGURE 07	HYDRAULIC DRIVE CYLINDER ASSEMBLY
FIGURE 08	DRIVE CYLINDER SUB-ASSEMBLY



PUMPING TRAIN INSTALLATION

XXT 32
PARTS
GROUP 60
FIGURE 01
PAGE 01

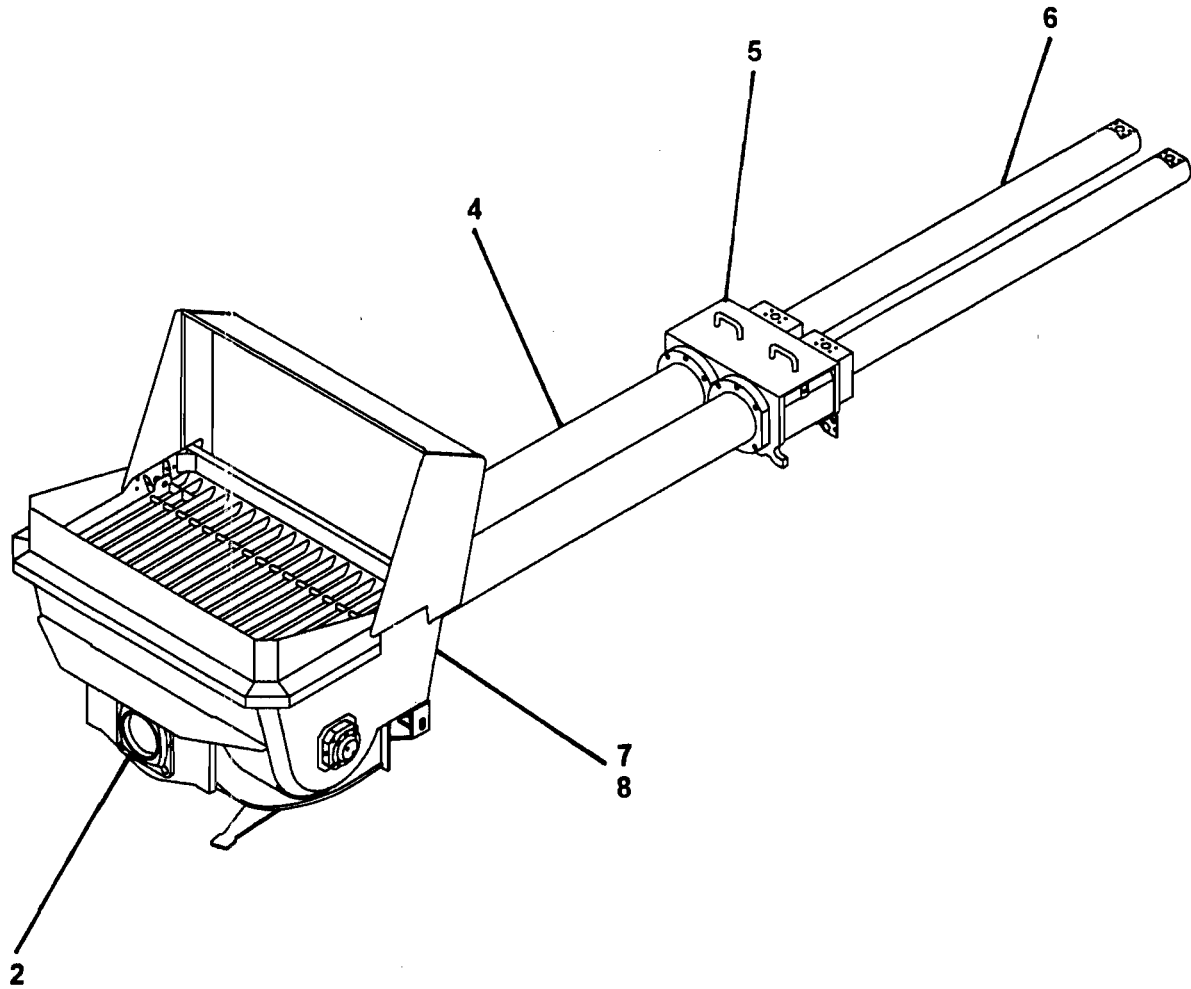

ITEM NO.	REED'S PARTS NO.	DESCRIPTION					QTY
		1	2	3	4	5	
-1	60-01	Installation, Pumping Train (See Group 10, Figure 01 for NHA)					Ref
2	B-174020	• Assembly, Swing Valve (See Group 60, Figure 02 for DET)					1
-3	B-174030	• Assembly, Tilting Drive (See Group 60, Figure 03 for DET)					1
4	B-124013	• Assembly, Concrete Cylinder (See Group 60, Figure 05 for DET)					1
5	B-143000	• Assembly, Water Box (See Group 60, Figure 06 for DET)					1
6	60-06	• Assembly, Hydraulic Drive Cylinder (See Group 60, Figure 07 for DET)					1
7	20-01	• Installation, Hopper (See Group 20, Figure 01 for REF)					Ref
-8	B-183000	• System, Central Lubrication (See Group 20, Figure 02 for REF)					Ref

DASH (-) ITEM NOT ILLUSTRATED



SWING VALVE ASSEMBLY

XXT 32
PARTS
GROUP 60
FIGURE 02
PAGE 01

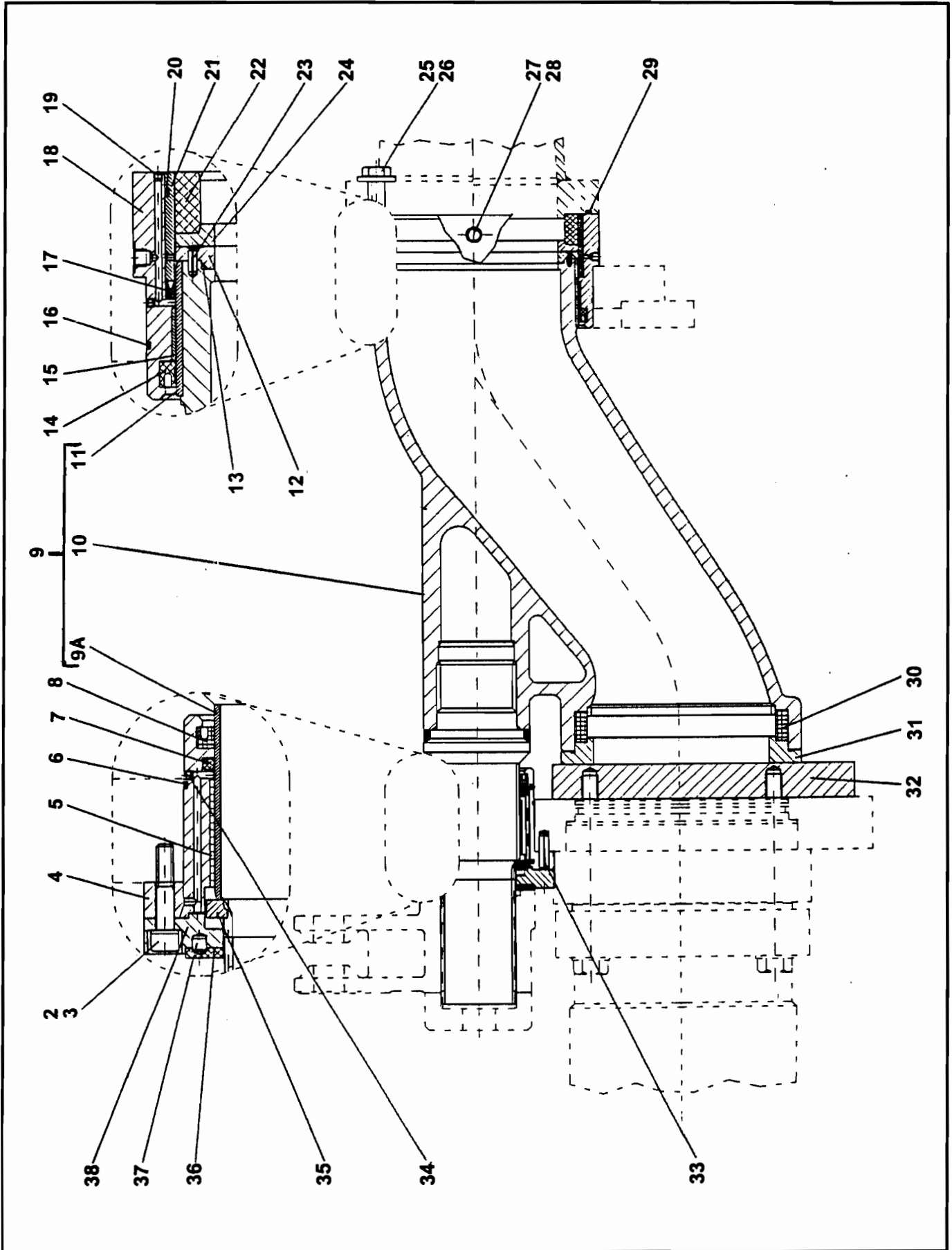

REVISION:

	REED'S PARTS NO.	1 2 3 4 5	DESCRIPTION	QTY
-1	B-174020		Assembly, Swing Valve (See Group 60, Figure 01 for NHA)	Ref
2	W-103151	•	Screw, M12	3
3	W-103113	•	Washer, Spring A12	3
4	B-174024	•	Housing, Small Bearing	1
5	W-100237	•	Bushing	1
6	W-100486	•	O-Ring	2
7	W-100485	•	O-Ring	2
8	W-100484	•	Ring, Groove	1
9	W-105223	•	Assembly, Swing Tube	1
9A	B-172105	• •	Bushing, Small	1
10	B-174089	• •	Valve, Swing DN 200	1
11	B-172107	• •	Bushing, Big	1
12	B-174027	•	Ring, Sliding	1
13	B-100625	•	O-Ring	1
14	W-100479	•	Ring, Groove	1
15	W-100236	•	Ring, Outlet Wear	1
16	W-100481	•	O-Ring	1
17	W-103078	•	Foreseal	1
18	B-174022	•	Housing, Big Bearing	1
19	W-100499	•	Screw, M5 Set	2
20	W-103365	•	O-Ring	1
21	B-174023	•	Ring, Spacer	1
22	W-100262	•	Ring, Outlet Wear	1
23	W-103077	•	Pin, Spring Type Straight	2
24	B-174028	•	Ring, Sliding	1
25	W-101589	•	Screw, M20 Hex	4
26	W-102110	•	Washer, A20	4
27	W-101621	•	Screw, M8 Hex	1
28	W-101269	•	Ring	1
29	W-101588	•	O-Ring	1
30	W-103378	•	Ring, Wear Ring Tension	1
31	B-174087	•	Ring, Wear	1
32	B-172112	•	Plate, Spectacle (2 Halves)	1
33	W-103076	•	Pin, Spring Type Straight	1
34	W-102710	•	Screw, M4 Set	4
35	B-174026	•	Profile	1
36	B-173012	•	Washer, Phenolic Axial Bearing	1
37	W-103080	•	Pin, Cylindrical	1
38	B-174025	•	Flange	1

DASH (-) ITEM NOT ILLUSTRATED

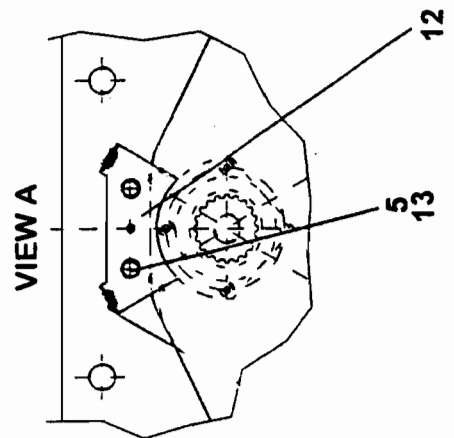
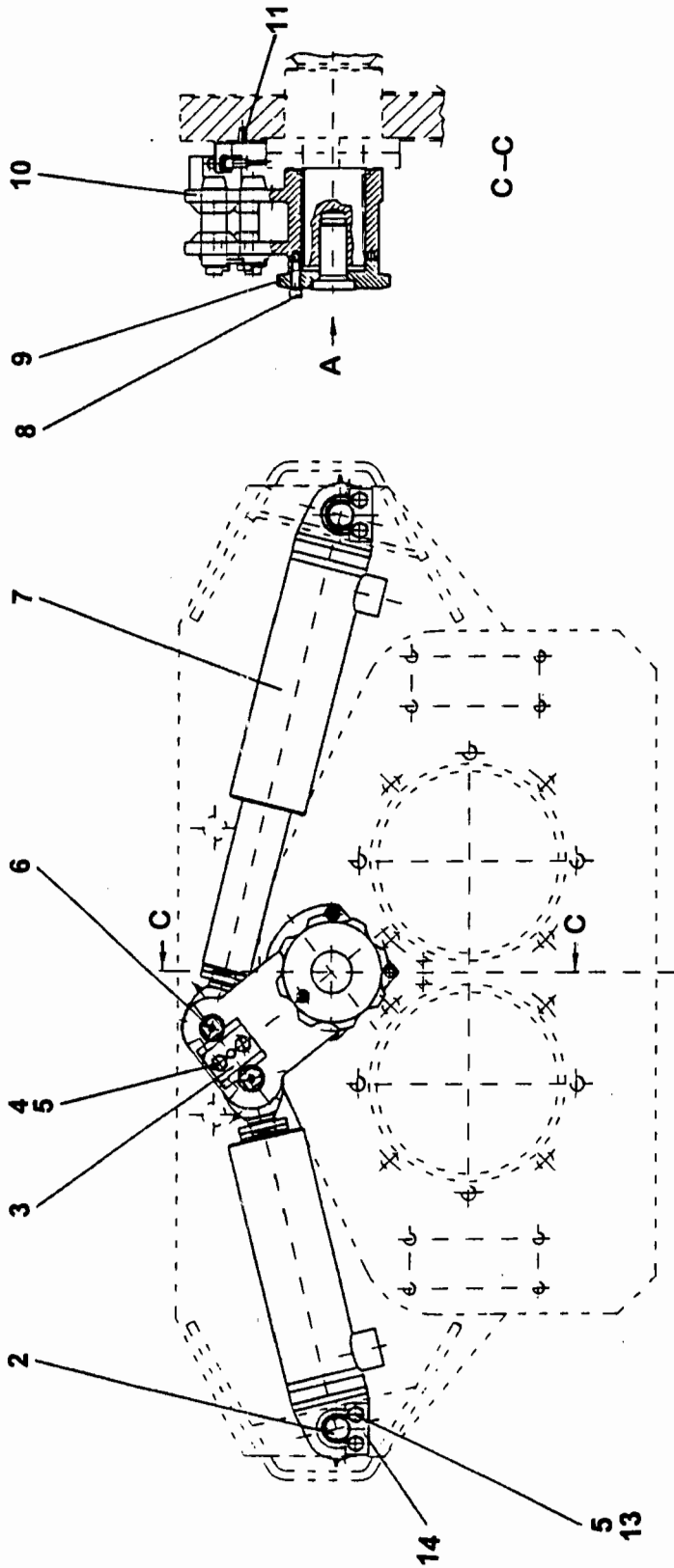

ITEM NO.	REED'S PARTS NO.	DESCRIPTION					QTY
		1	2	3	4	5	
-1	B-174030	Assembly, Tilting Drive (See Group 60, Figure 01 for NHA)					Ref
2	B-173066	• Pin, Safety					2
3	B-174083	• Plate, Key					1
4	W-102107	• Screw, M12 Hex					2
5	W-102877	• Washer, A12					8
6	B-173019	• Pin					2
7	W-103363	• Assembly, Tilting Cylinder (See Group 60, Figure 04 for DET)					2
8	B-174035	• Screw, M10 Hex (attaching parts)					1
9	B-174032	• Plate, Tension					1
10	B-174031	• Lever, Tilting					1
11	W-102881	• Pin, Spring Type Straight					1
12	B-174084	• Bracket, Sensor					1
13	W-101001	• Bolt, M12					6
14	B-173067	• Plate, Safety Pin					2

DASH (-) ITEM NOT ILLUSTRATED



TILTING CYLINDER ASSEMBLY

XXT 32
PARTS
GROUP 60
FIGURE 04
PAGE 01

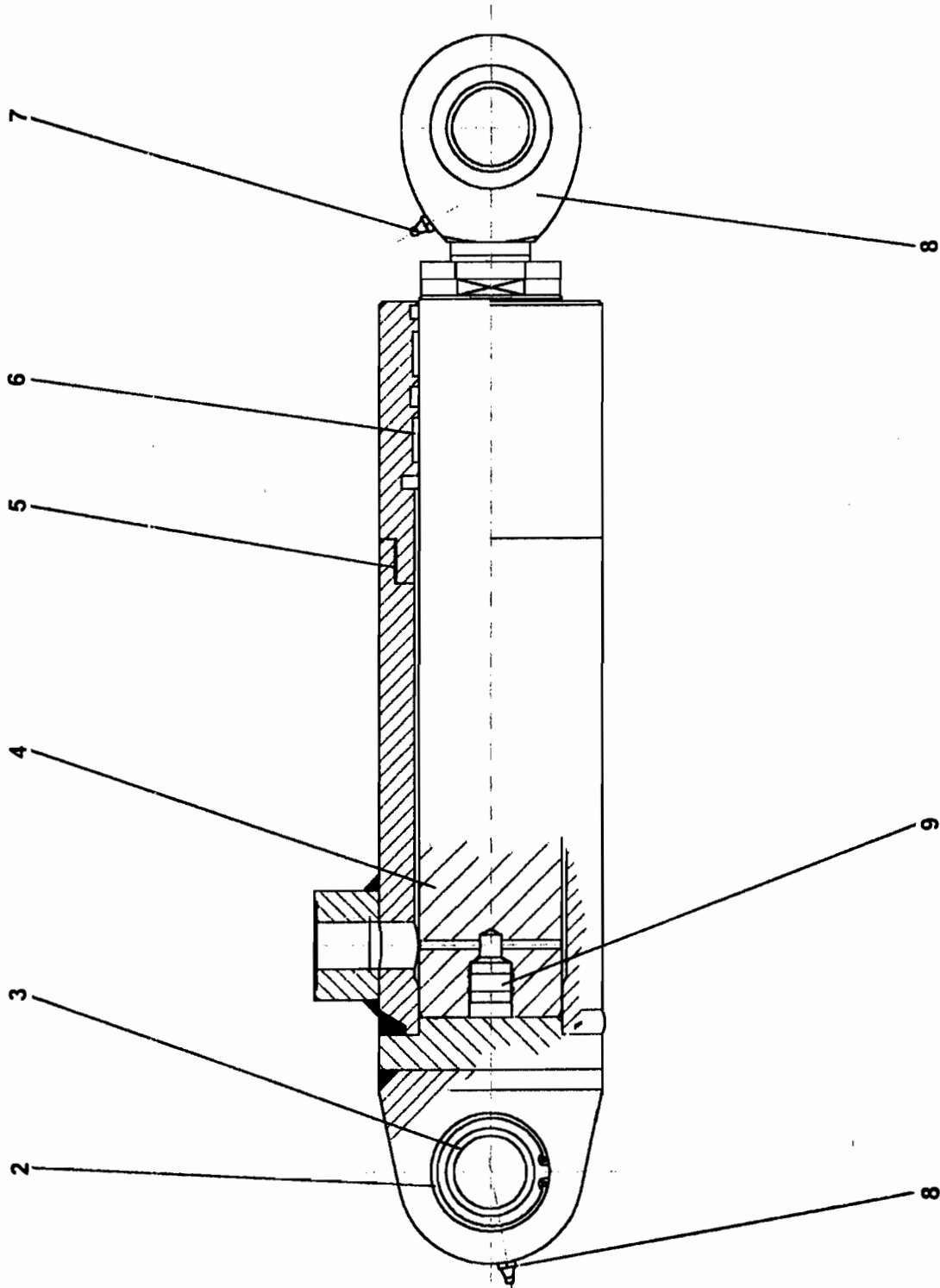

REVISION:



TILTING CYLINDER ASSEMBLY

XXT 32
PARTS
GROUP 60
FIGURE 04
PAGE 02

ITEM NO.	REED'S PARTS NO.	DESCRIPTION					QTY
		1	2	3	4	5	
-1	W-103363	Assembly, Tilting Cylinder (See Group 60, Figure 03 for NHA)					Ref
2	W-103626	• Bearing					1
3	W-101973	• Ring, Retaining					1
4	W-104438	• Rod, Piston					1
5	W-104440	• Pipe, Cylinder					1
6	W-103364	• Kit, Seal					1
7	W-100805	• Nipple, Grease					2
8	W-104437	• Valve, Check					1
9	W-104439	• Head, Rod					1

DASH (-) ITEM NOT ILLUSTRATED

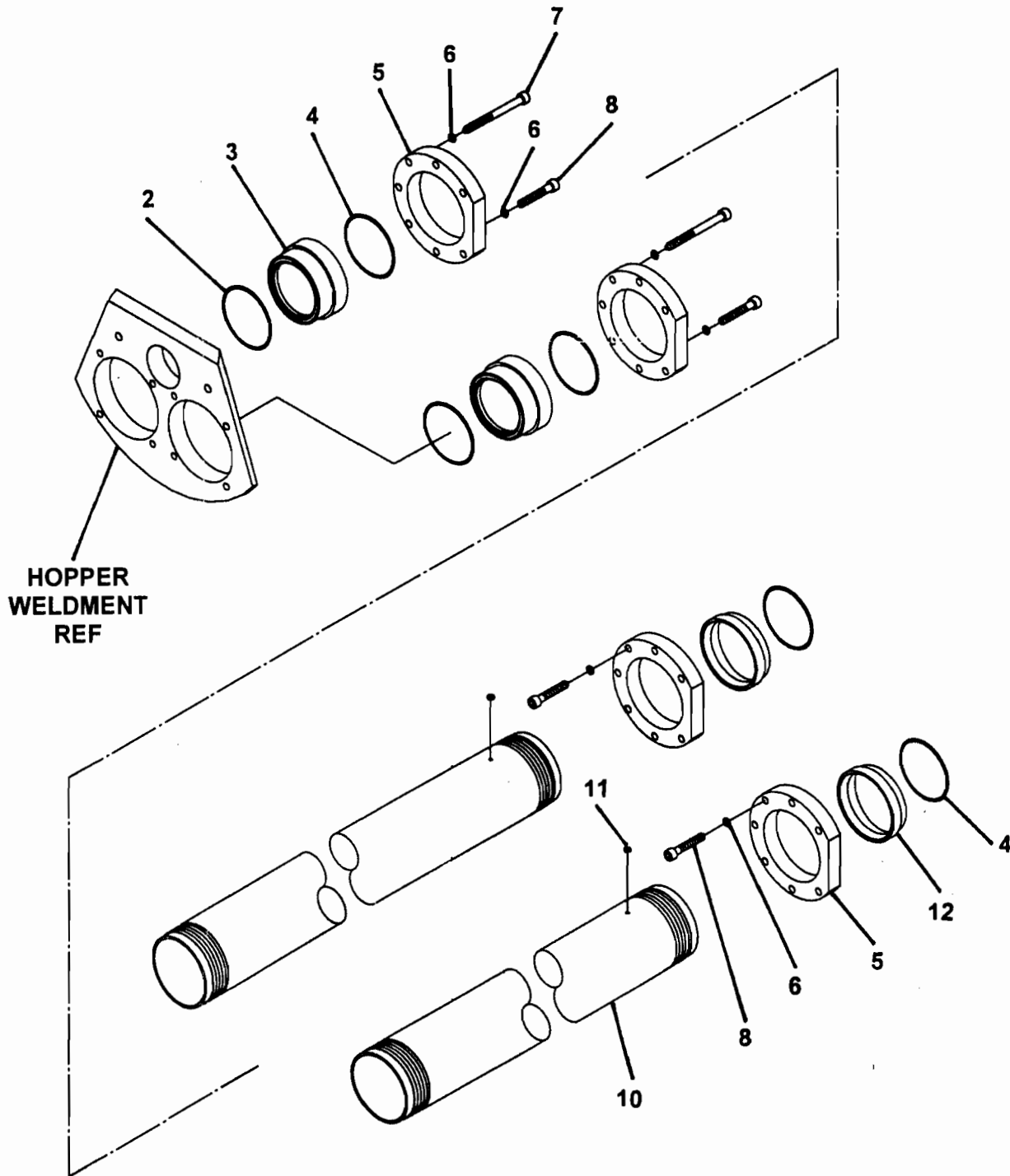



CONCRETE CYLINDER ASSEMBLY

XXT 32
PARTS
GROUP 60
FIGURE 05
PAGE 02

ITEM NO.	REED'S PARTS NO.	DESCRIPTION					QTY
		1	2	3	4	5	
-1	B-124017	Assembly, Concrete Cylinder (See Group 60, Figure 01 for NHA)					Ref
2	W-101090	• O-Ring					2
3	B-124015	• Ring, Fitting					2
4	W-102868	• O-Ring					4
5	B-123007	• Flange					4
6	W-100691	• Washer					28
7	W-102885	• Bolt, M20					6
8	W-103970	• Screw, M20					14
-9	W-102845	• Bolt, M20					8
10	B-123011	• Cylinder, Concrete					2
11		• Fitting, Grease					2
12	B-123012	• Ring, Fitting					2

DASH (-) ITEM NOT ILLUSTRATED

WATER BOX ASSEMBLY

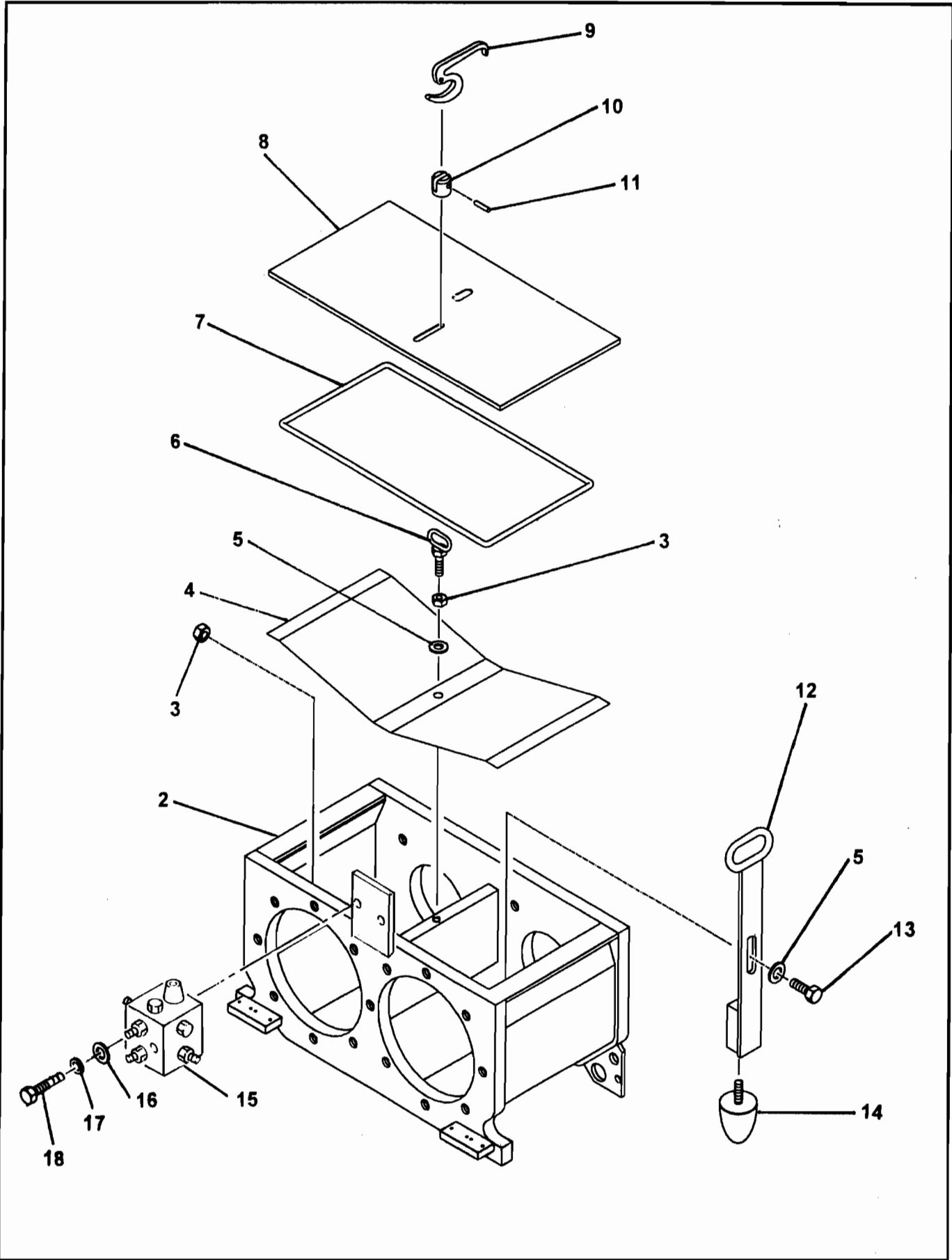



WATER BOX ASSEMBLY

XXT 32
PARTS
GROUP 60
FIGURE 06
PAGE 02

ITEM NO.	REED'S PARTS NO.	DESCRIPTION					QTY
		1	2	3	4	5	
-1	B-143030	Assembly, Water Box (See Group 60, Figure 01 for NHA)					Ref
2	B-143031	• Weldment, Water Box					1
3	W-101557	• Nut, M12 Hex					2
4	B-143020	• Cover, Safety					1
5	W-100504	• Washer					2
6	B-143009	• Bolt, M12 Eye					1
7	W-101831	• Seal, Round Cord					1
8	B-143015	• Cover, Water Box					1
9	B-143007	• Lever					1
10		• Head, Eye Bolt					1
11	W-103387	• Pin, Grooved					1
12	B-143011	• Handle					1
13	W-103688	• Bolt, M12 Hex					1
14	W-102712	• Buffer, Rubber					1
15	W-104402	• Block, Lube					1
16		• Washer, Flat (attaching parts)					2
17		• Washer, Lock (attaching parts)					2
18		• Bolt, Hex (attaching parts)					2

DASH (-) ITEM NOT ILLUSTRATED

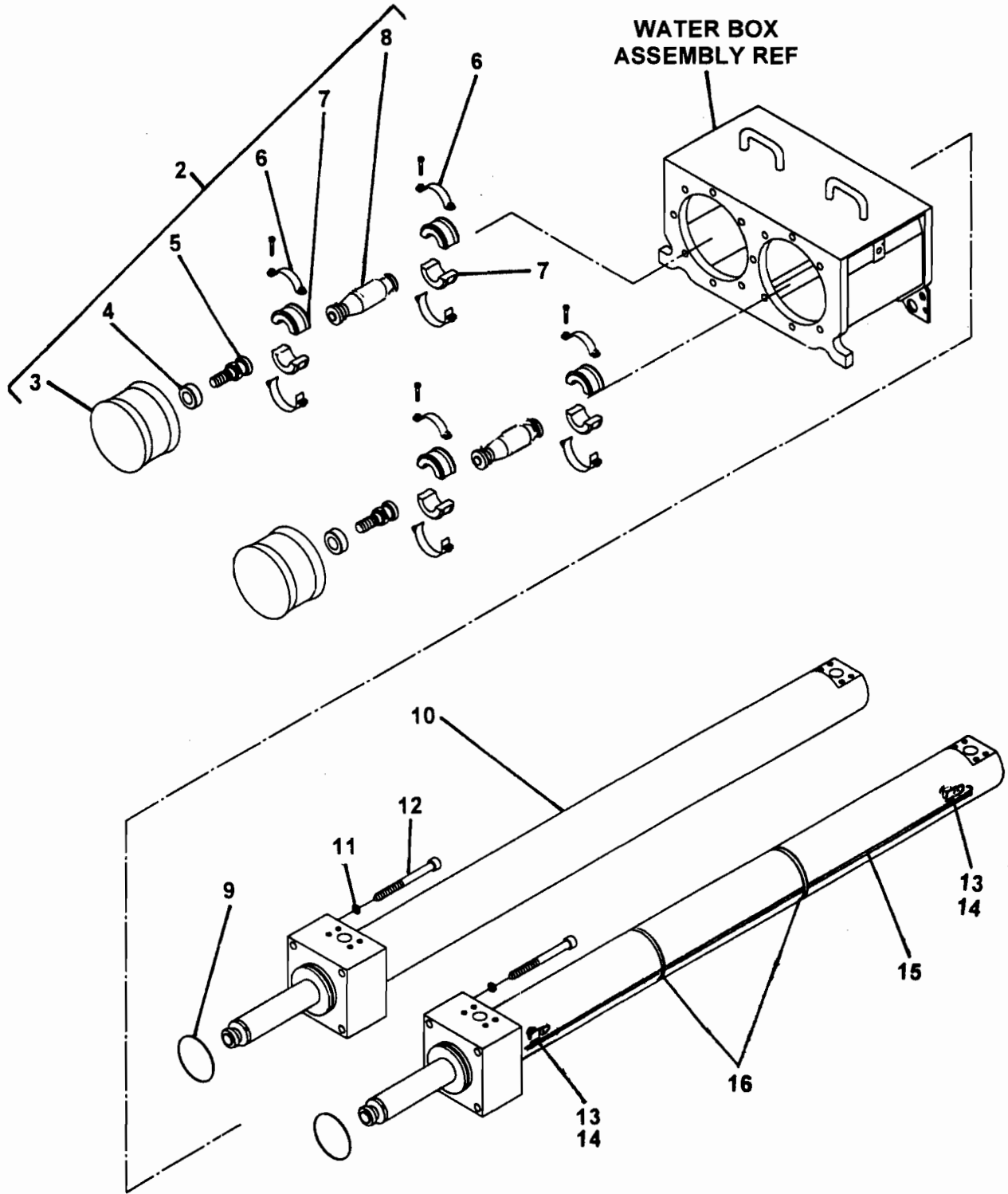



HYDRAULIC DRIVE CYLINDER ASSEMBLY

XXT 32
PARTS
GROUP 60
FIGURE 07
PAGE 02

ITEM NO.	REED'S PARTS NO.	DESCRIPTION					QTY
		1	2	3	4	5	
-1	60-06	Assembly, Hydraulic Drive Cylinder (See Group 60, Figure 01 for NHA)					Ref
2	B-133012	• Assembly, Piston Ram					1
3	W-100175	• • Ram, Piston					2
4	W-100934	• • Ring, Fitting					2
5	B-131003	• • Pin, Coupling					2
6	W-101381	• • Clamp, Hose					4
7	B-131004	• • Coupling, Clamp					4
8	B-133003	• • Adapter, Dog Bone					2
9	W-100190	• O-Ring					2
10	B-154030	• Sub-Assembly, Hydraulic Drive Cylinder (See Group 60, Figure 08 for DET)					2
11	W-103070	• Washer (attaching parts)					6
12	W-102846	• Bolt (attaching parts)					6
13	79285	• Guard, Prox Switch					2
14	78416	• Switch, Prox					2
15	78417	• Cable, Prox Switch					2
16		• Tie-Down (attaching parts)					2

DASH (-) ITEM NOT ILLUSTRATED

HYDRAULIC DRIVE CYLINDER SUB-ASSEMBLY

XXT 32
PARTS
GROUP 60
FIGURE 08
PAGE 01

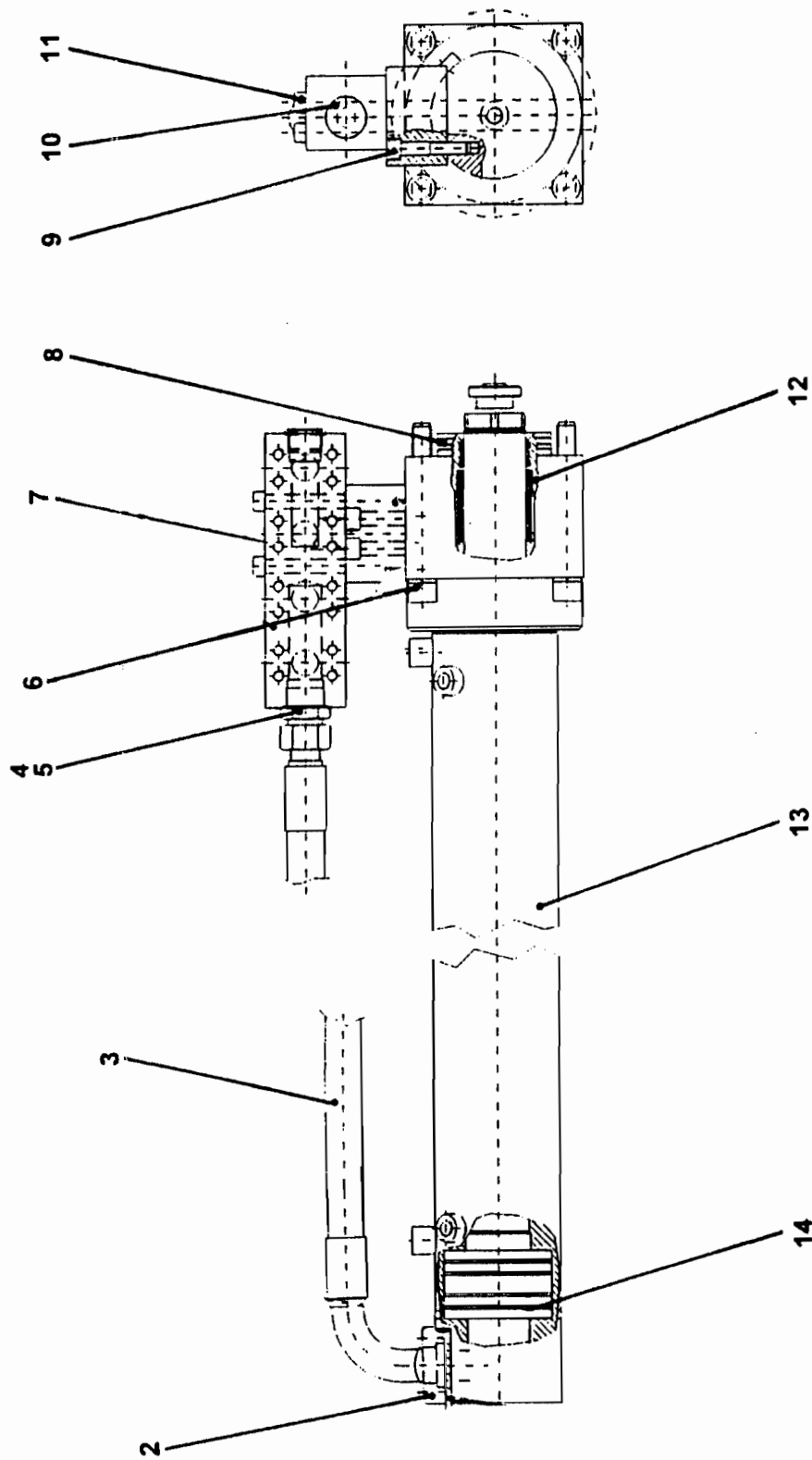



HYDRAULIC DRIVE CYLINDER SUB-ASSEMBLY

XXT 32
PARTS
GROUP 60
FIGURE 08
PAGE 02

ITEM NO.	REED'S PARTS NO.	DESCRIPTION					QTY
		1	2	3	4	5	
-1	B-154030	Sub-Assembly, Hydraulic Drive Cylinder (See Group 60, Figure 07 for NHA)					Ref
2	W-102305	• Flange (set)					1
3		• Assembly, High Pressure Hose					1
4	W-102846	• Screw, M24					4
5	W-103070	• Washer, Spring					4
6	W-102184	• Coupling, Straight Male Stud					1
7	B-153002	• Box, Hydraulic					1
8	W-100190	• O-Ring					1
9		• Screw, M16					4
10	W-103347	• Screw, Locking					1
11		• Screw, M16					4
12	W-102393	• Set, Seal					1
13	W-102504	• Cylinder, Drive					1
14	W-105049	• Ring, Piston					4
-15	B-153003	• Block, Hydraulic					1
-16	78416	• Sensor, Proximity					2
-17	78417	• Cable, Proximity Sensor					2
-18	79285	• Guard, Proximity Sensor					2
-19		• Valve, Check					2

DASH (-) ITEM NOT ILLUSTRATED

REED

**MODEL XXT 32 TRUCK MOUNTED
CONCRETE BOOM PUMP
ILLUSTRATED PARTS MANUAL**

**XXT 32
PARTS
GROUP 60
FIGURE 09
PAGE 01**

THIS PAGE INTENTIONALLY LEFT BLANK.

REED TRUCK MOUNTED CONCRETE BOOM PUMP MODEL **XXT 32** ILLUSTRATED PARTS MANUAL GROUP 70 FRAME AND SUPPORT INSTALLATION CONTAINS THE FOLLOWING FIGURES:

- FIGURE 00** TABLE OF CONTENTS
- FIGURE 01** FRAME AND SUPPORT INSTALLATION
- FIGURE 02** TURRET ASSEMBLY
- FIGURE 03** MOTOR AND REDUCTION ASSEMBLY
- FIGURE 04** ROTATION UNIT ASSEMBLY
- FIGURE 05** SUPPORT FRAME STABILIZERS ASSEMBLY
- FIGURE 06** FRONT LEFT STABILIZERS TELESCOPIC LEG ASSEMBLY
- FIGURE 07** FRONT RIGHT STABILIZERS TELESCOPIC LEG ASSEMBLY
- FIGURE 08** REAR LEFT SWING OUT LEG ASSEMBLY
- FIGURE 09** REAR RIGHT SWING OUT LEG ASSEMBLY
- FIGURE 10** STABILIZERS VERTICAL JACK CYLINDER ASSEMBLY
- FIGURE 11** SWING OUT CYLINDER ASSEMBLY

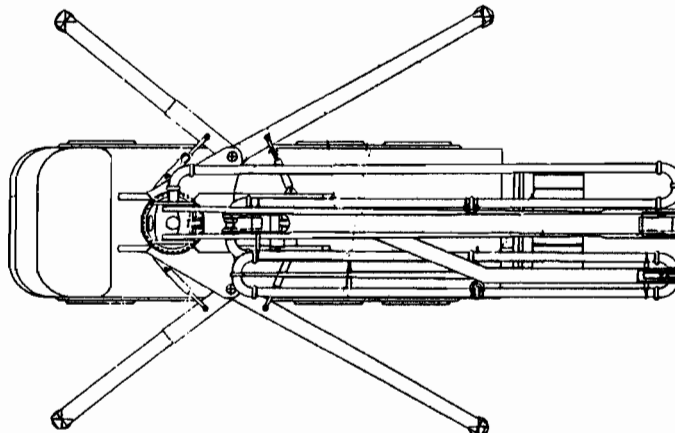
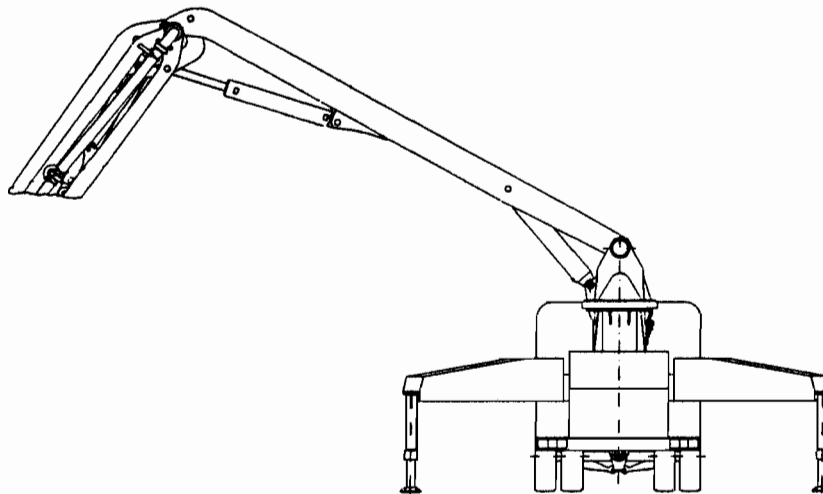

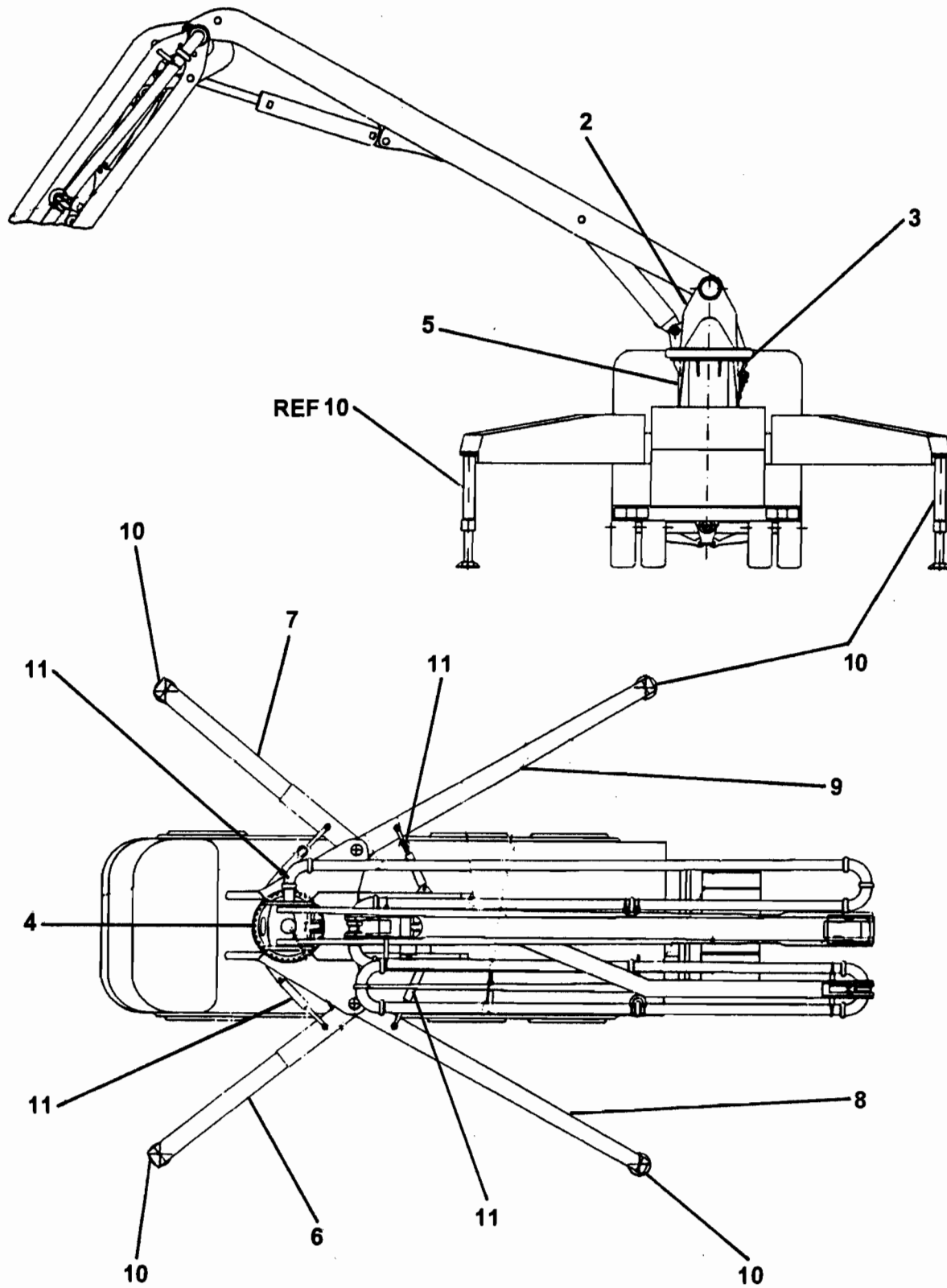

ITEM NO.	REED'S PARTS NO.	DESCRIPTION					QTY
		1	2	3	4	5	
-1	70-01	Installation, Frame And Support (See Group 10, Figure 01 for NHA)					Ref
2	C-3F1	• Assembly, Turret (See Group 70, Figure 02 for DET)					1
3	C-3G1	• Assembly, Motor And Reduction (See Group 70, Figure 03 for DET)					1
4	C-3G2	• Assembly, Rotation Unit (See Group 70, Figure 04 for DET)					1
5	C-9H1	• Assembly, Support Frame Stabilizers (See Group 70, Figure 05 for DET)					1
6	C-9K1-L	• Assembly, Front Left Side Stabilizers Telescopic Leg (See Group 70, Figure 06 for DET)					1
7	C-9K1-R	• Assembly, Front Right Side Stabilizers Telescopic Leg (See Group 70, Figure 07 for DET)					1
8	C-9M1-L	• Assembly, Rear Left Side Swing Out Leg (See Group 70, Figure 08 for DET)					1
9	C-9M1-R	• Assembly, Rear Right Side Swing Out Leg (See Group 70, Figure 09 for DET)					1
10	C-6L5	• Assembly, Stabilizer Vertical Jack Cylinder (See Group 70, Figure 10 for DET)					4
11	C-8M3	• Assembly, Swing Out Cylinder (See Group 70, Figure 11 for DET)					4

DASH (-) ITEM NOT ILLUSTRATED

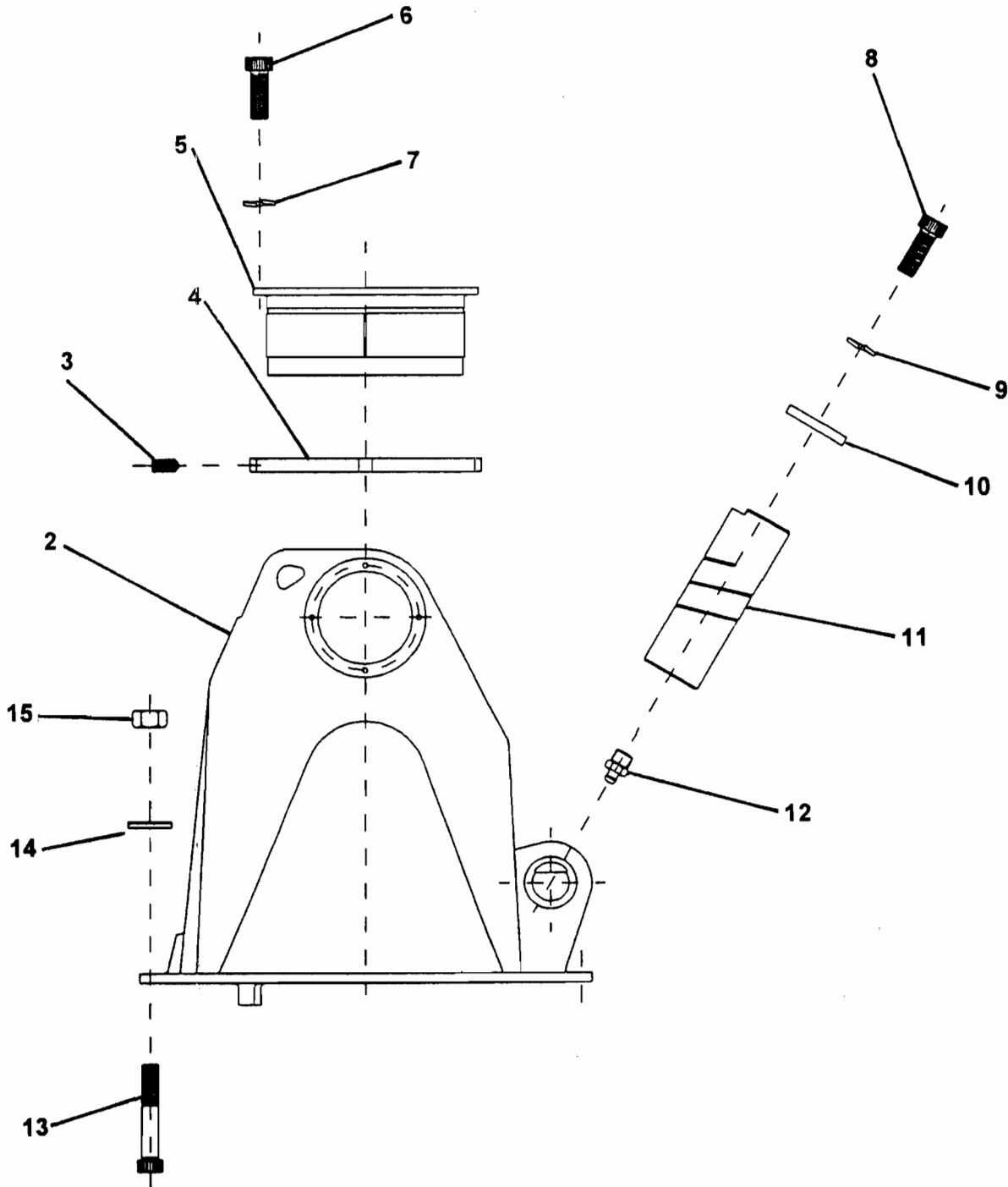
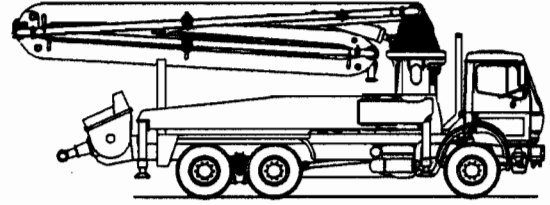
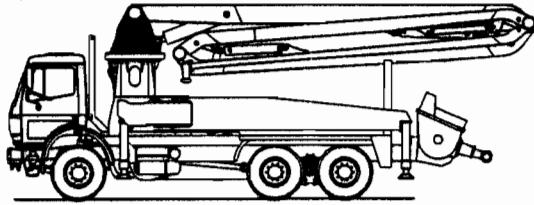



TURRET ASSEMBLY

XXT 32
PARTS
GROUP 70
FIGURE 02
PAGE 02

ITEM NO.	REED'S PARTS NO.	DESCRIPTION					QTY
		1	2	3	4	5	
-1	C-3F1	Assembly, Turret (See Group 70, Figure 01 for NHA)					Ref
2	C-3F101	• Head, Rotating					1
3	C-VG122.061010	• Screw					4
4	C-GV228.2015	• Ring, Threaded					2
5	C-4P118	• Pin					2
6	C-VC110.142040	• Screw					8
7	C-UE110.14	• Washer, Elastic					8
8	C-VC110.101525	• Screw					1
9	C-UE110.10	• Washer, Elastic					1
10	C-UD080.1106	• Washer, Pin Locking					1
11	C-3P116A	• Pin					1
12	C-VI131.1010	• Nipple, Grease					1
13	C-VC130.2225C6	• Screw					48
14	C-UP110.22	• Washer					48
15	C-VD113.2225	• Nut					48

DASH (-) ITEM NOT ILLUSTRATED



MOTOR AND REDUCTION ASSEMBLY

XXT 32
PARTS
GROUP 70
FIGURE 03
PAGE 01

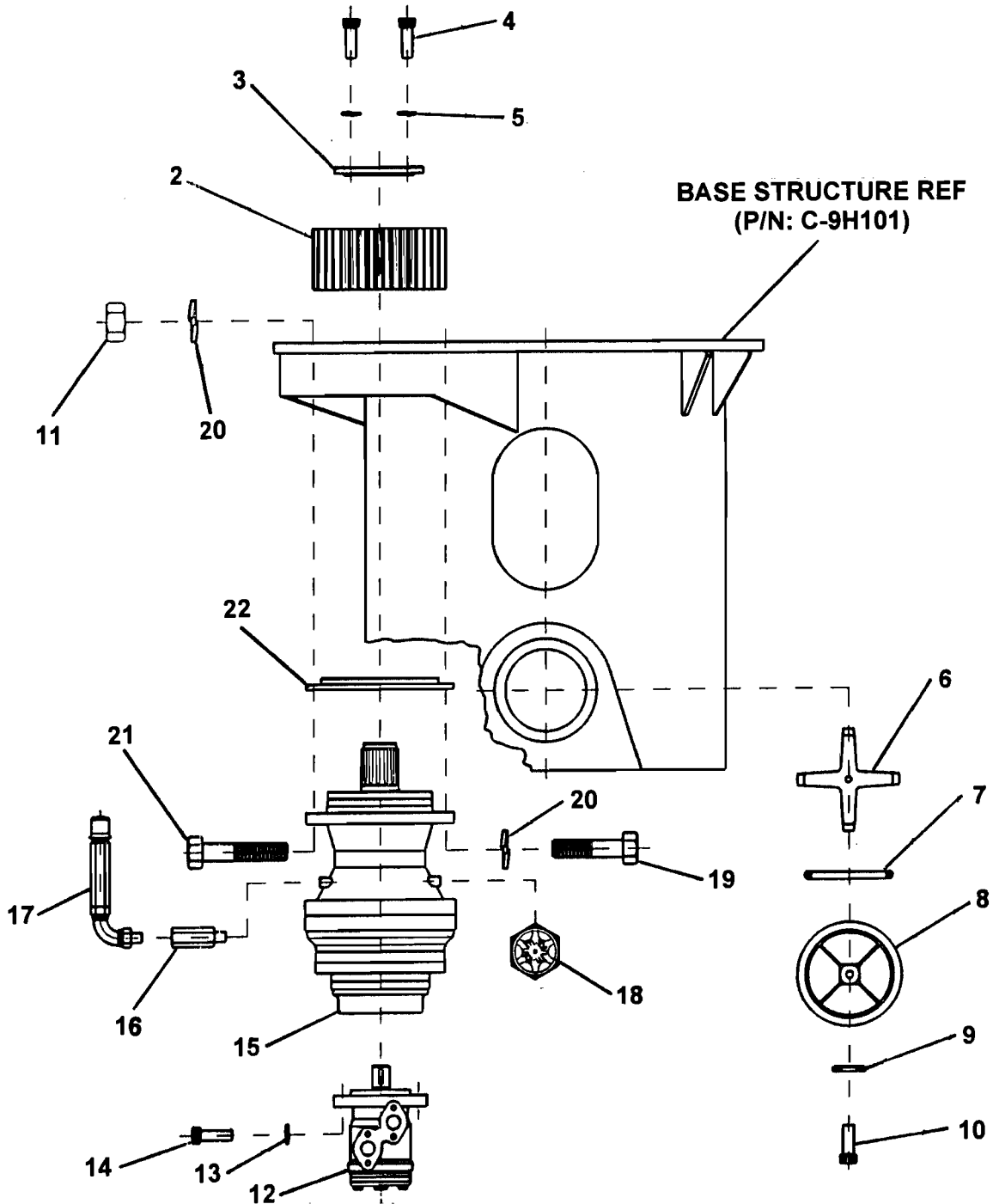
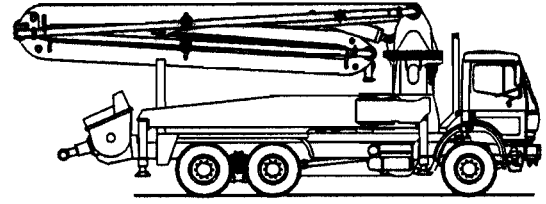
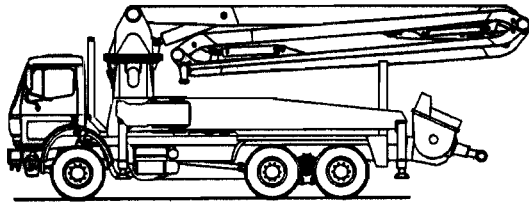

ITEM NO.	REED'S PARTS NO.	DESCRIPTION					QTY
		1	2	3	4	5	
-1	C-3G1	Assembly, Motor And Reduction (See Group 70, Figure 01 for NHA)					Ref
2	C-RP114.120	• Pinion					1
3	C-RP100	• Washer, Pinion					1
4	C-VC110.101530	• Screw					3
5	C-UE110.10	• Washer, Elastic					3
6	C-DT301	• Support, Cover					1
7	C-A0120.371	• Gasket, Seal					1
8	C-DT300	• Cover					1
9	C-AB110.016	• Ring-Bonded					1
10	C-VC110.162040	• Screw					1
11	C-VD111.1620	• Nut					7
12	C-MI110.300	• Assembly, Hydraulic Motor					1
13	C-UE110	• Washer, Elastic					4
14	C-VC110	• Screw					4
15	C-RE040.11201	• Unit, Reduction					1
16	C-NP020.040MF	• Fitting					1
17	C-FS020	• Filter, Air Hole					1
18	C-LL301	• Level, Oil					1
19	C-VE110.162055	• Screw					3
20	C-UE110.16	• Washer, Elastic					10
21	C-VE110.162075	• Screw					3
22	C-3G102	• Flange, Adjusting Coupling					1

DASH (-) ITEM NOT ILLUSTRATED

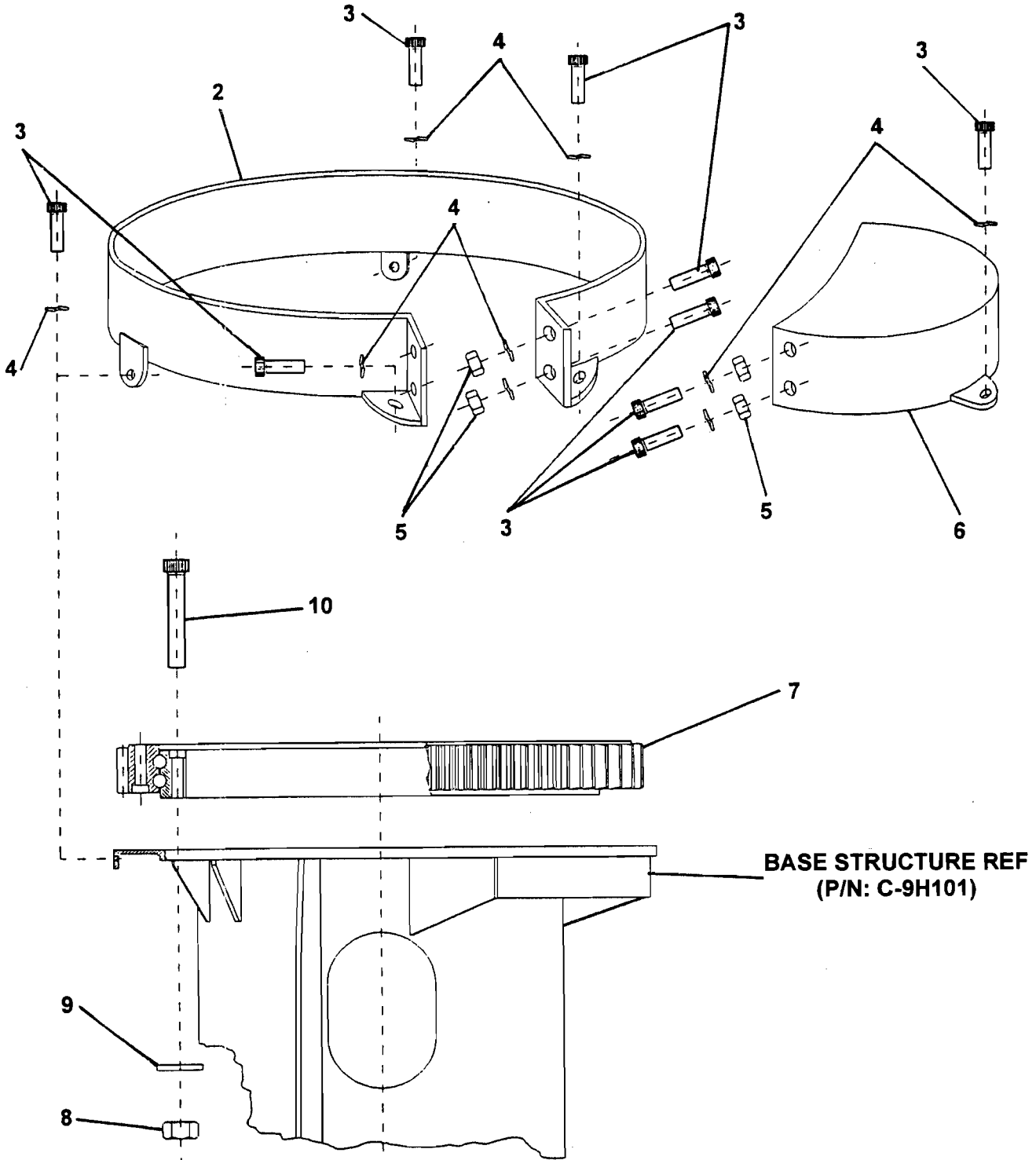
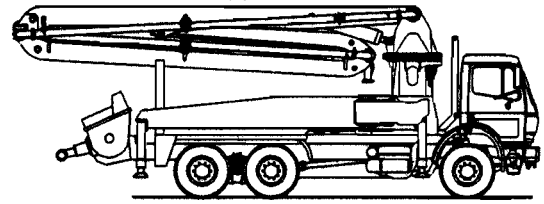
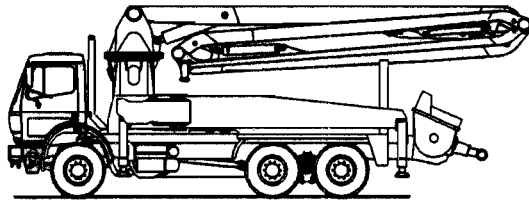



ROTATION UNIT ASSEMBLY

XXT 32
PARTS
GROUP 70
FIGURE 04
PAGE 02

ITEM NO.	REED'S PARTS NO.	DESCRIPTION					QTY
		1	2	3	4	5	
-1	C-3G2	Assembly, Rotation Unit (See Group 70, Figure 01 for NHA)					Ref
2	C-3G204	• Protection, Rotating					1
3	C-VC110.081225	• Screw					9
4	C-UE110.08	• Washer, Elastic (attaching parts)					9
5	C-VD111.0815	• Nut					4
6	C-3G203	• Protection, Pinion					1
7	C-B112.1164	• Bearing, Rotation					1
8	C-VD113.2225	• Nut (attaching parts)					48
9	C-UP110.22	• Washer (attaching parts)					48
10	C-VC130.2225C6	• Screw (attaching parts)					48

DASH (-) ITEM NOT ILLUSTRATED



SUPPORT FRAME STABILIZERS ASSEMBLY

XXT 32
PARTS
GROUP 70
FIGURE 05
PAGE 01

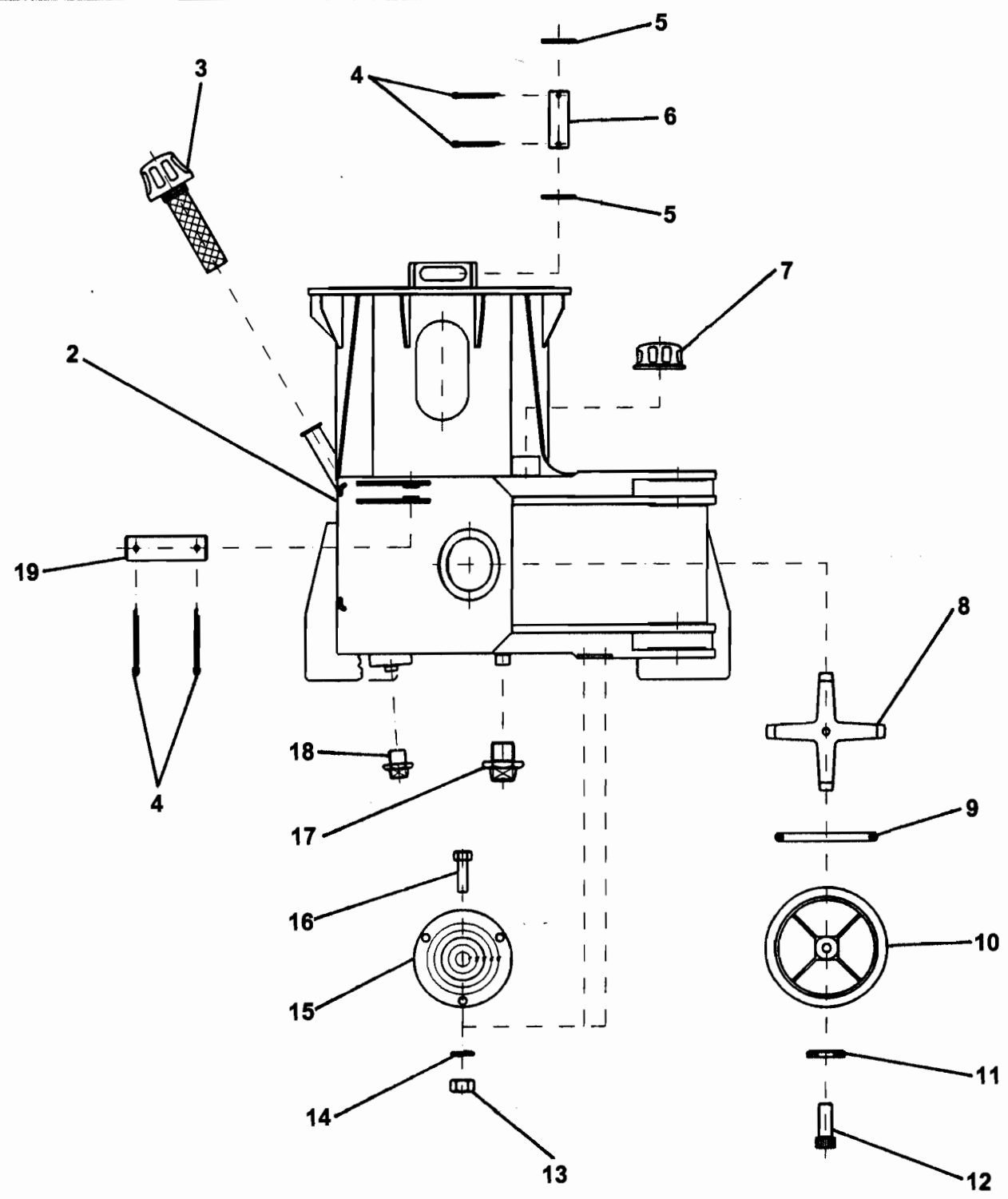
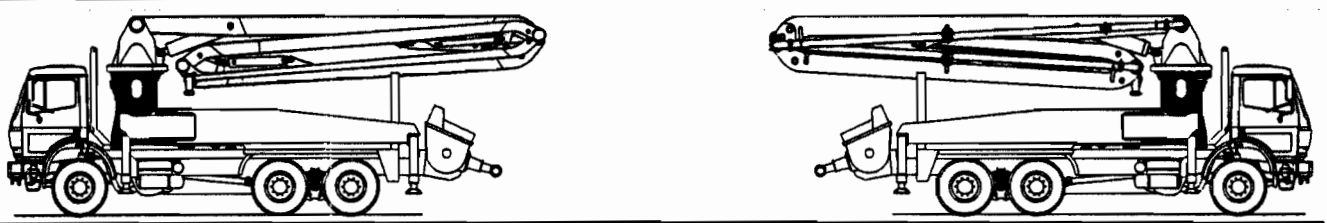

REVISION:

ITEM NO.	REED'S PARTS NO.	DESCRIPTION	QTY
-1	C-9H1	Assembly, Support Frame Stabilizers (See Group 70, Figure 01 for NHA)	Ref
2	C-9H101	• Structure, Base	1
3	C-DT200	• Plug, Screw for Hydraulic Oil Tank	1
4	C-VS110.08070	• Pin, Split	6
5	C-3G205	• Washer	2
6	C-3P202	• Pin	1
7	C-DT121	• Plug, Screw for Water Tank	1
8	C-DT301	• Support, Cover	2
9	C-A0120.371	• Gasket, Seal	2
10	C-DT300	• Cover	2
11	C-AB110.016	• Ring-Bonded	2
12	C-VC110.162040	• Screw	2
13	C-VD111.0407	• Nut	3
14	C-UE110.04	• Washer, Elastic	3
15	C-LL401	• Level	1
16	C-VE110.040715	• Screw	3
17	C-DT109	• Plug, Screw	2
18	C-DT105	• Plug, Screw	3
19	C-1P201	• Pin	2

DASH (-) ITEM NOT ILLUSTRATED

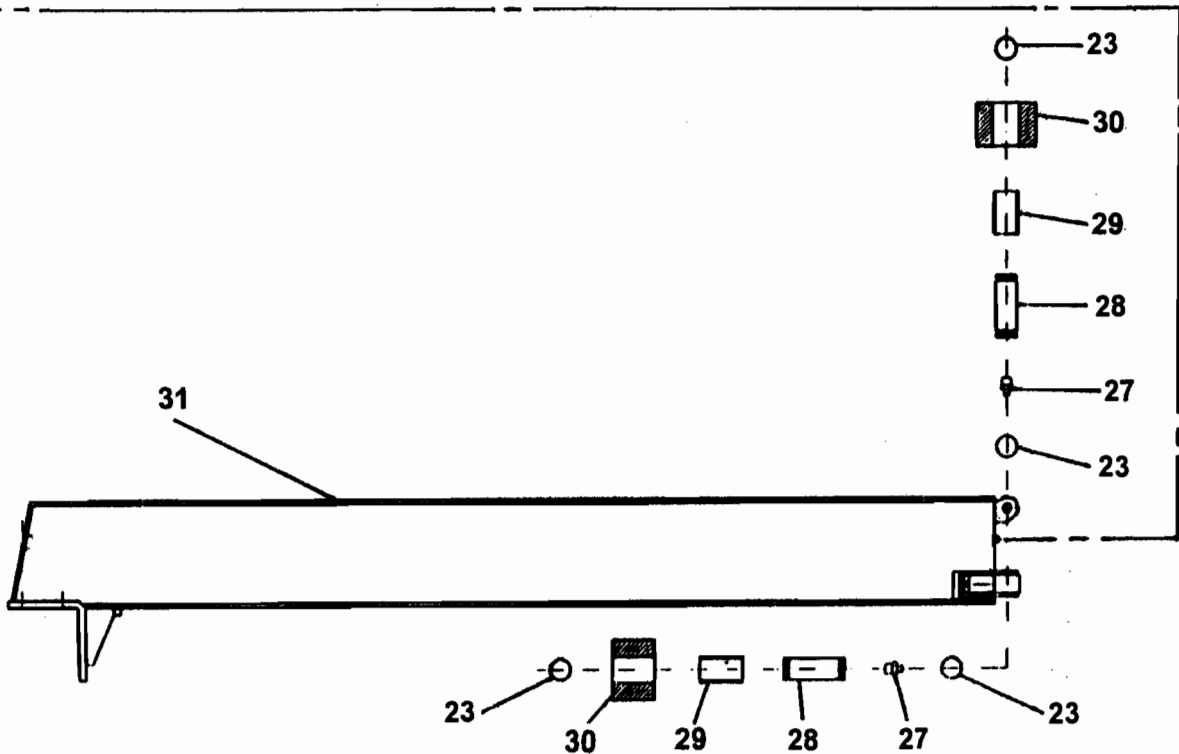
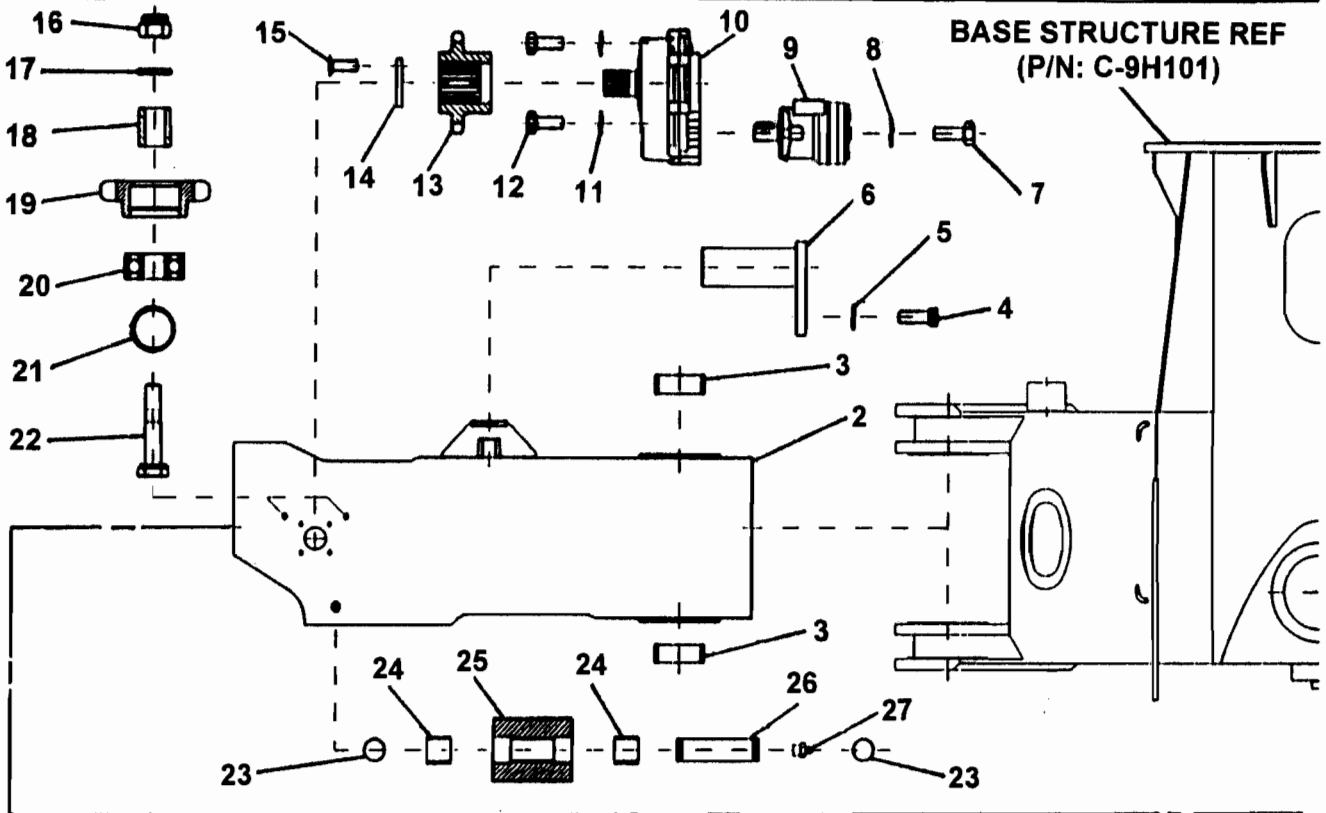
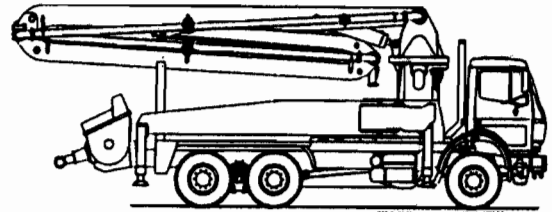
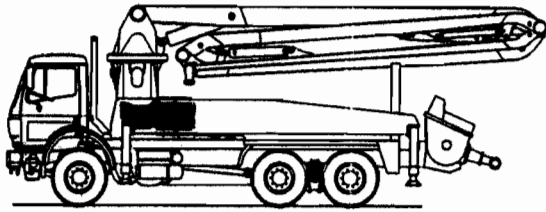

ITEM NO.	REED'S PARTS NO.	DESCRIPTION					QTY
		1	2	3	4	5	
-1	C-9K1-L	Assembly, Front Stabilizers Left Side Telescopic Leg (See Group 70, Figure 01 for NHA)					Ref
2	C-9K102	• Weldment, Front Left Side Stabilizers					1
3	C-CD180.185060	• Bearing, Anti-friction					2
4	C-VE110.081220	• Screw					1
5	C-UE100.08	• Washer, Elastic					1
6	C-9P206	• Pin					1
7	C-VE110.121725	• Screw					2
8	C-UE110.12	• Washer, Elastic					2
9	C-MI300.250	• Assembly, Hydraulic Motor					1
10	C-RE003.00075	• Reducer					1
11	C-UE110.10	• Washer, Elastic					4
12	C-VE110.101535	• Screw					4
13	C-9K108	• Pinion					1
14	C-9K112	• Washer					1
15	C-VT110.031025	• Screw					3
16	C-VD221.1420	• Nut, Self Locking					2
17	C-UE110.14	• Washer					2
18	C-9K111	• Piece, Distance					2
19	C-9K109	• Pinion, Free					2
20	C-CC63002.2RS	• Bearing, Ball					2
21	C-AA120.032	• Ring, Clamping					2
22	C-9K110	• Pin					2
23	C-AA110.025	• Ring, Clamping					6
24	C-CD025.02825	• Bearing, Anti-friction					2
25	C-5H105	• Roller					1
26	C-3P206	• Pin					1
27	C-VI131.0608	• Nipple, Grease					3
28	C-4P201	• Pin					2
29	C-CD025.02850	• Bearing, Anti-friction					2
30	C-4H102	• Roller					2
31	C-9K202	• Weldment, Front Left Side Telescopic Leg					1

DASH (-) ITEM NOT ILLUSTRATED

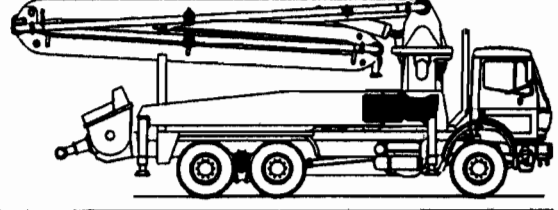
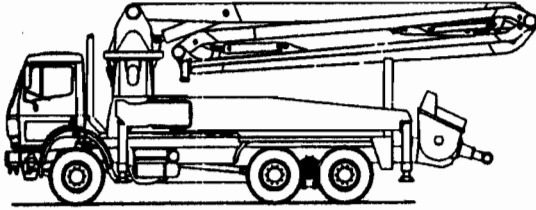

BASE STRUCTURE REF
(P/N: C-9H101)

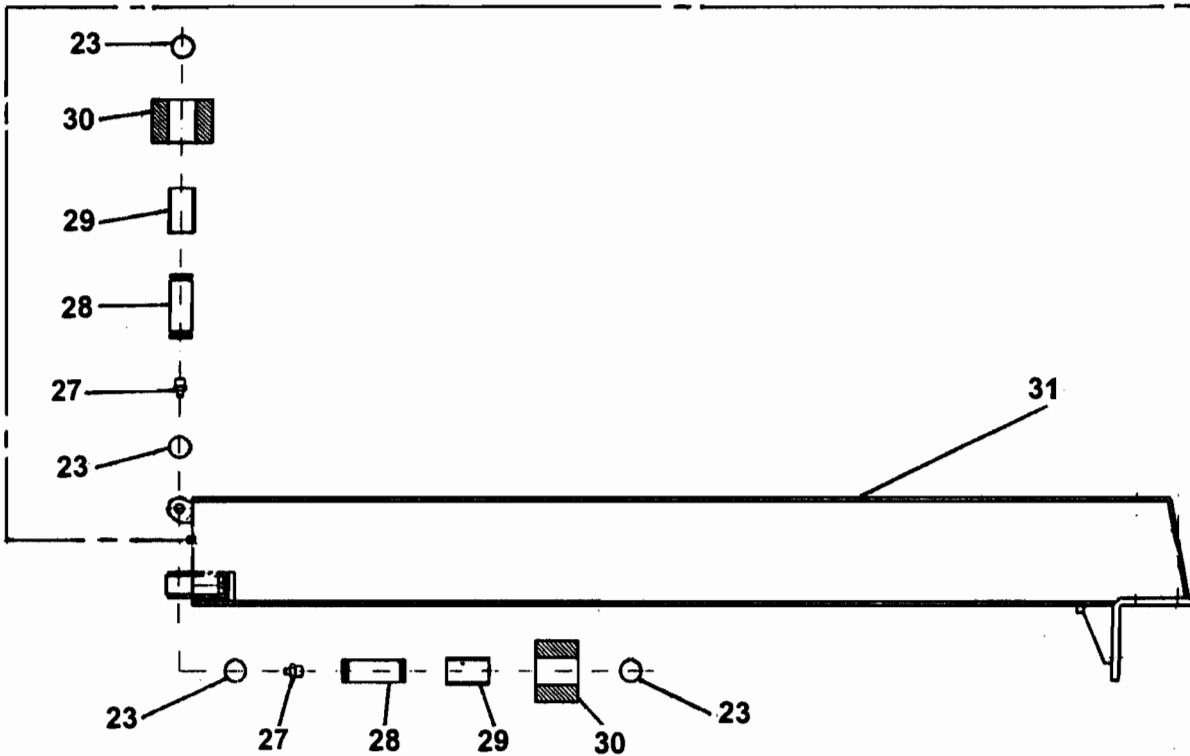
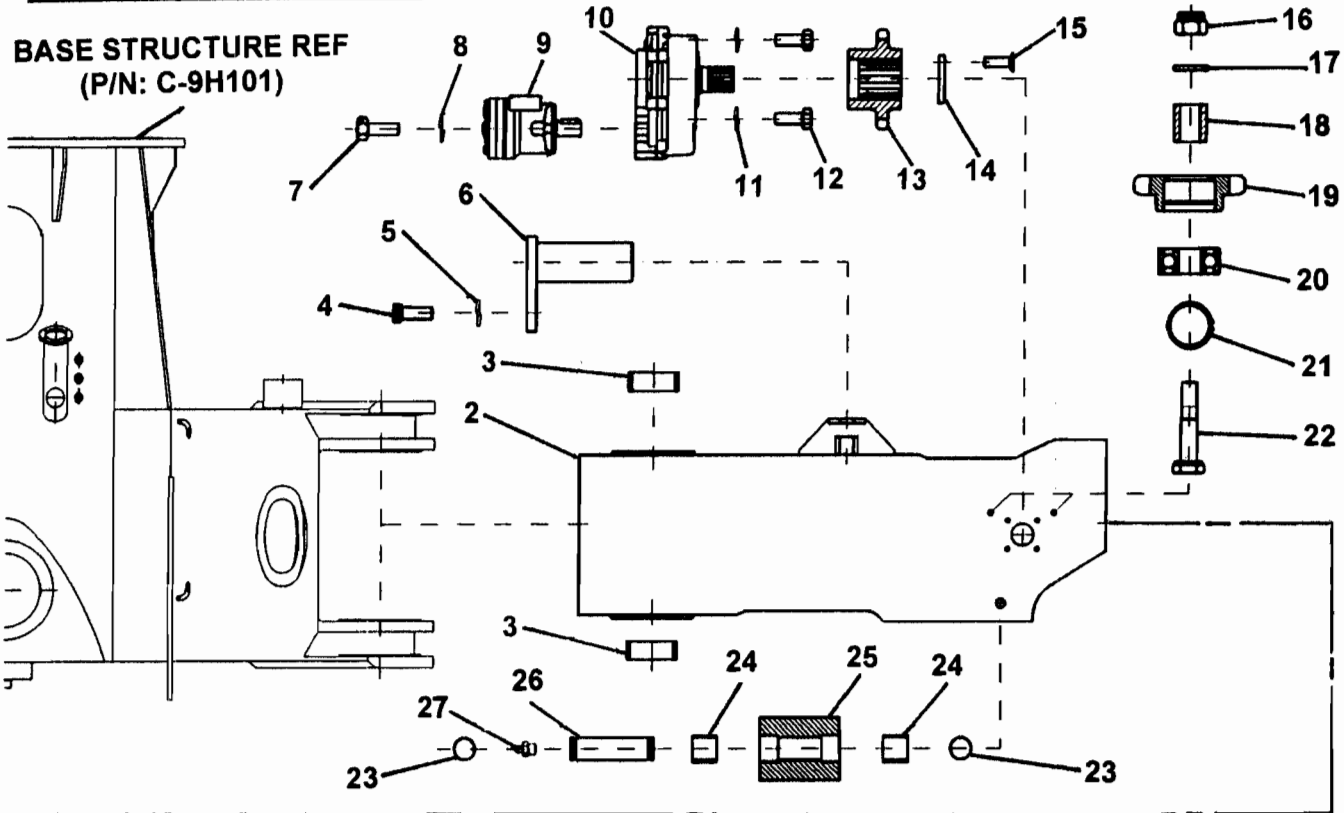

ITEM NO.	REED'S PARTS NO.	DESCRIPTION	QTY
-1	C-9K1-R	Assembly, Front Stabilizers Right Side Telescopic Leg (See Group 70, Figure 01 for NHA)	Ref
2	C-9K101	• Weldment, Front Right Side Stabilizers	1
3	C-CD180.185060	• Bearing, Anti-friction	2
4	C-VE110.081220	• Screw	1
5	C-UE100.08	• Washer, Elastic	1
6	C-9P206	• Pin	1
7	C-VE110.121725	• Screw	2
8	C-UE110.12	• Washer, Elastic	2
9	C-MI300.250	• Assembly, Hydraulic Motor	1
10	C-RE003.00075	• Reducer	1
11	C-UE110.10	• Washer, Elastic	4
12	C-VE110.101535	• Screw	4
13	C-9K108	• Pinion	1
14	C-9K112	• Washer	1
15	C-VT110.031025	• Screw	3
16	C-VD221.1420	• Nut, Self Locking	2
17	C-UE110.14	• Washer	2
18	C-9K111	• Piece, Distance	2
19	C-9K109	• Pinion, Free	2
20	C-CC63002.2RS	• Bearing, Ball	2
21	C-AA120.032	• Ring, Clamping	2
22	C-9K110	• Pin	2
23	C-AA110.025	• Ring, Clamping	6
24	C-CD025.02825	• Bearing, Anti-friction	2
25	C-5H105	• Roller	1
26	C-3P206	• Pin	1
27	C-VI131.0608	• Nipple, Grease	3
28	C-4P201	• Pin	2
29	C-CD025.02850	• Bearing, Anti-friction	2
30	C-4H102	• Roller	2
31	C-9K201	• Weldment, Front Right Side Telescopic Leg	1

DASH (-) ITEM NOT ILLUSTRATED

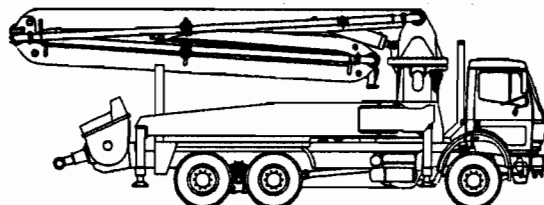
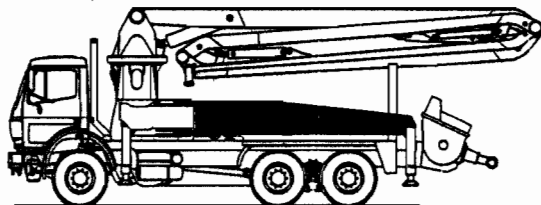

BASE STRUCTURE REF
(P/N: C-9H101)

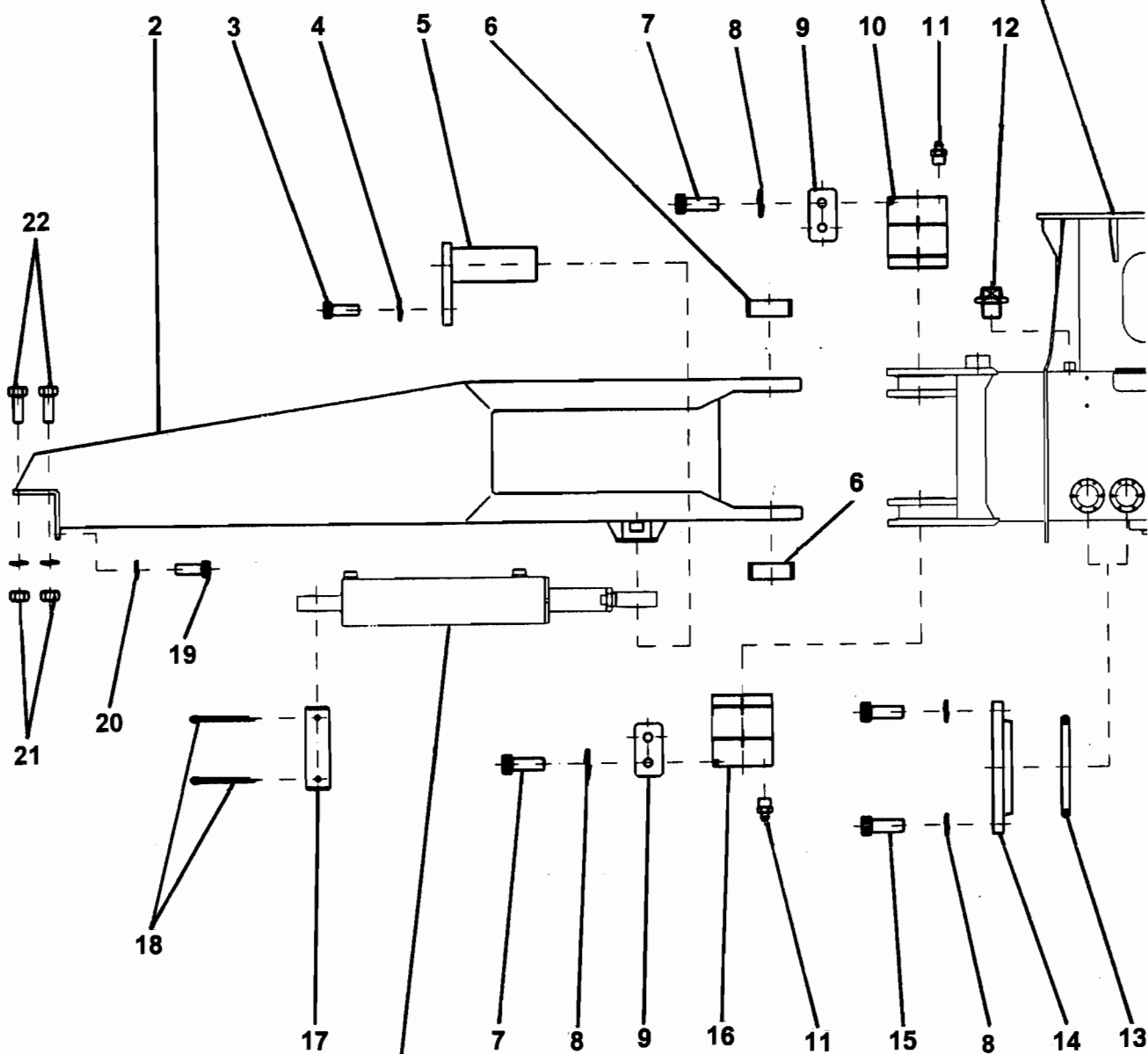

REAR SWING OUT
CYLINDER REF
(P/N: C-8M3)



REAR LEFT SIDE SWING OUT LEG ASSEMBLY

XXT 32
PARTS
GROUP 70
FIGURE 08
PAGE 02

ITEM NO.	REED'S PARTS NO.	DESCRIPTION					QTY
		1	2	3	4	5	
-1	C-9M1-L	Assembly, Rear Left Side Swing Out Leg (See Group 70, Figure 01 for NHA)					Ref
2	C-9M1021	• Stabilizer, Rear Left Side					1
3	C-VE110.081220	• Screw					1
4	C-UE110.08	• Washer, Elastic					1
5	C-9P206	• Pin					1
6	C-CD180.185060	• Bearing, Anti Friction					2
7	C-VC110.121730	• Screw					4
8	C-UE110.12	• Washer, Elastic					19
9	C-3M105	• Plate, Embed					2
10	C-9P202	• Pin, Left Side Top					1
11	C-VI131.1010	• Nipple, Grease					4
12	C-DT105	• Plug, Screw					1
13	C-AO420.4412	• Seal, Gasket					A/R
14	C-1H102.53	• Cover					A/R
15	C-VE110.121725	• Screw					15
16	C-9P205	• Pin, Left Side Bottom					1
17	C-1P201	• Pin					1
18	C-VS110.08070	• Pin, Split					2
19	C-VC110.222550	• Screw					2
20	C-UE110.22	• Washer, Elastic					6
21	C-VD111.2225	• Nut					4
22	C-EC110.222580	• Screw					4

DASH (-) ITEM NOT ILLUSTRATED

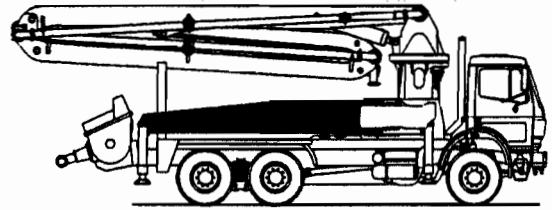
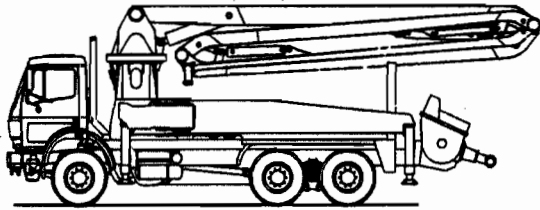

BASE STRUCTURE REF
(P/N: C-9H101)

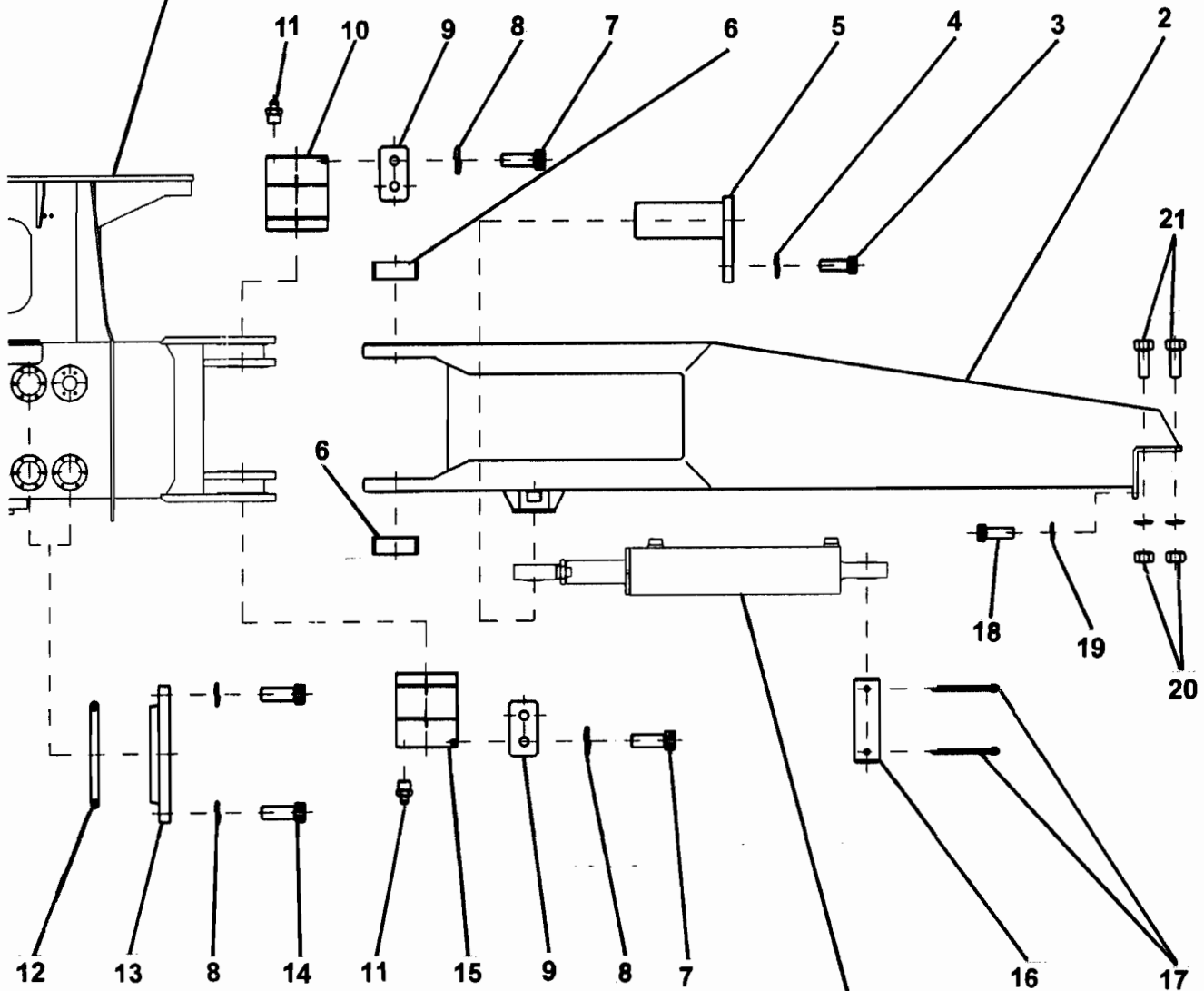

**REAR SWING OUT
CYLINDER REF**
(P/N: C-8M3)

REED**REAR RIGHT SIDE
SWING OUT LEG ASSEMBLY****XXT 32
PARTS
GROUP 70
FIGURE 09
PAGE 02**

ITEM NO.	REED'S PARTS NO.	DESCRIPTION					QTY
		1	2	3	4	5	
-1	C-9M1-R	Assembly, Rear Right Side Swing Out Leg (See Group 70, Figure 01 for NHA)					Ref
2	C-9M1021	• Stabilizer, Rear Right Side					1
3	C-VE110.081220	• Screw					1
4	C-UE110.08	• Washer, Elastic					1
5	C-9P206	• Pin					1
6	C-CD180.185060	• Bearing, Anti Friction					2
7	C-VC110.121730	• Screw					4
8	C-UE110.12	• Washer, Elastic					19
9	C-3M105	• Plate, Embed					2
10	C-9P203	• Pin, Right Side Top					1
11	C-VI131.1010	• Nipple, Grease					4
12	C-AO420.4412	• Seal, Gasket					A/R
13	C-1H102.53	• Cover					A/R
14	C-VE110.121725	• Screw					15
15	C-9P204	• Pin, Right Side Bottom					1
16	C-1P201	• Pin					1
17	C-VS110.08070	• Pin, Split					2
18	C-VC110.222550	• Screw					2
19	C-UE110.22	• Washer, Elastic					6
20	C-VD111.2225	• Nut					4
21	C-EC110.222580	• Screw					4

DASH (-) ITEM NOT ILLUSTRATED

REVISION:

REED

STABILIZER VERTICAL JACK CYLINDER ASSEMBLY

XXT 32
PARTS
GROUP 70
FIGURE 10
PAGE 01

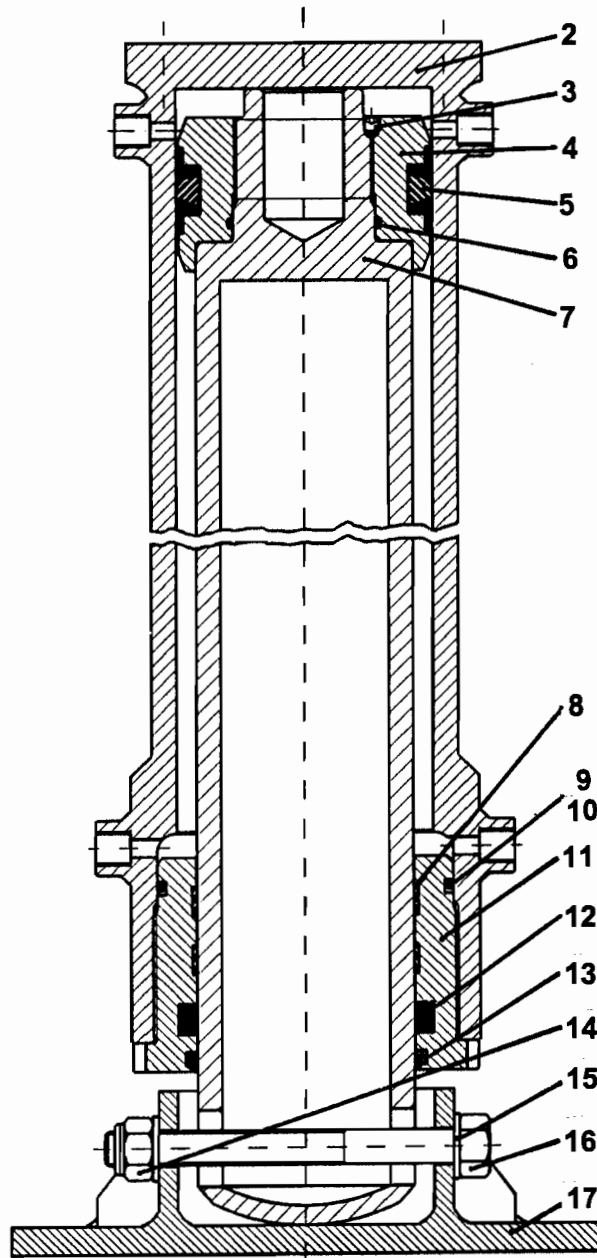
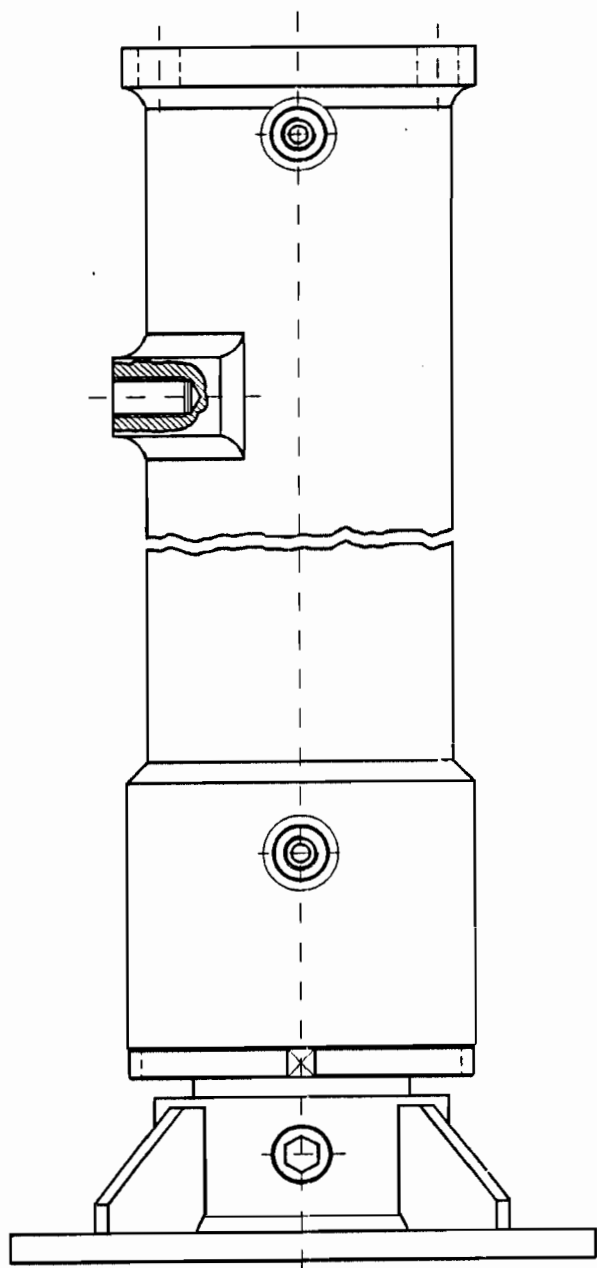
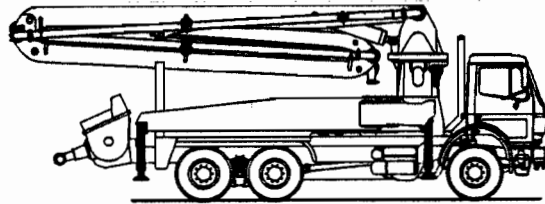
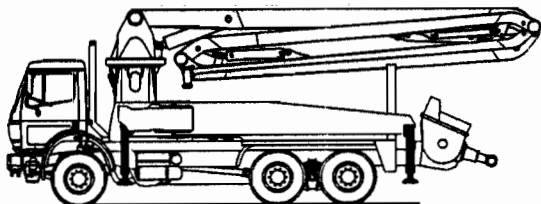

REVISION:

REED**STABILIZER VERTICAL JACK
CYLINDER ASSEMBLY****XXT 32
PARTS
GROUP 70
FIGURE 10
PAGE 02**

ITEM NO.	REED'S PARTS NO.	DESCRIPTION					QTY
		1	2	3	4	5	
-1	C-6L5	Assembly, Stabilizers Jack Cylinder (See Group 70, Figure 01 for NHA)					Ref
2	C-6L502	• Cylinder					1
3	C-VG122.081010	• Screw					1
4	C-4K512	• Piston					1
5	C-BS23511413	• Gasket, Seal					1
6	C-AO420.174	• Gasket, Seal					1
7	C-6L507	• Rod					1
8	C-AG123.110	• Ring, Slide Rod					2
9	C-AO120.357	• Gasket, Seal					1
10	C-AP110.357	• Gasket, Seal					1
11	C-4K501	• Head, Slide Rod					1
12	C-BT110.110	• Gasket, Seal					1
13	C-BR310.110	• Gasket, Seal					1
14	C-VD112.1825	• Nut, Self Locking					1
15	C-UP110.18	• Washer, Elastic					2
16	C-VE112.1825C8	• Screw, Foot					1
17	C-6K519	• Foot					1

DASH (-) ITEM NOT ILLUSTRATED

REVISION:

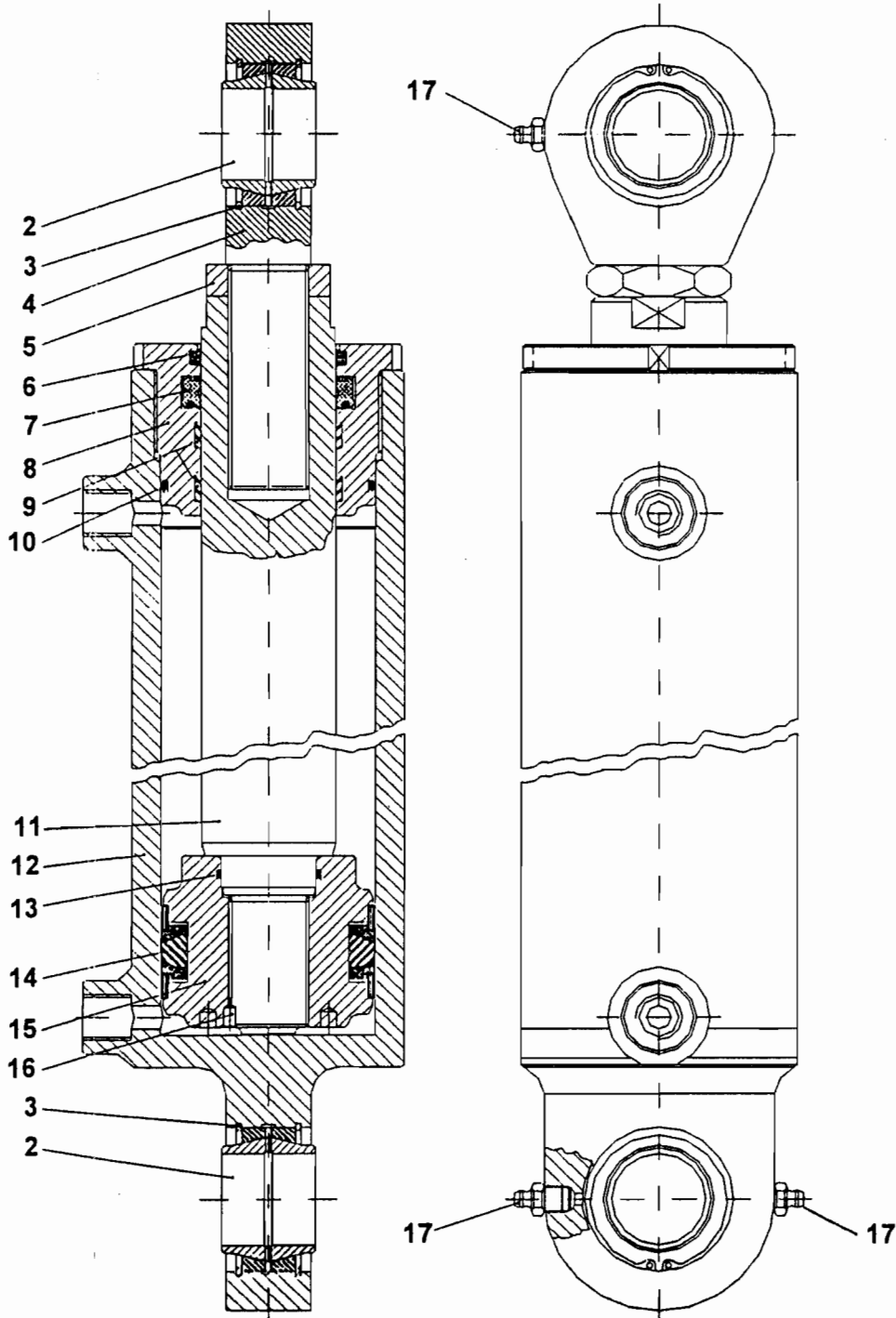
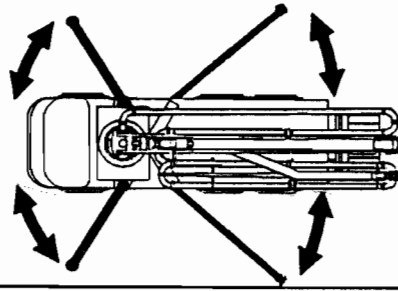



SWING OUT CYLINDER ASSEMBLY

XXT 32
PARTS
GROUP 70
FIGURE 11
PAGE 02

ITEM NO.	REED'S PARTS NO.	DESCRIPTION					QTY
		1	2	3	4	5	
-1	C-8M3	Assembly, Rear Swing Out Cylinder (See Group 70, Figure 01 for NHA)					Ref
2	C-CT223.035	• Joint, Ball					2
3	C-AA120.055	• Ring, Clamping					4
4	C-8M308	• Cap, Rod					1
5	C-3M325	• Nut					1
6	C-BR210.196228	• Gasket, Seal					1
7	C-BT110.050	• Gasket, Seal					1
8	C-3M301	• Head, Slide Rod					1
9	C-AG122.050	• Ring, Slide Rod					2
10	C-AO420.4287	• Ring, Sealing					1
11	C-8M307	• Rod					1
12	C-8M302	• Cylinder					1
13	C-AO120.126	• Ring, Sealing					1
14	C-BS23314236	• Gasket, Seal					1
15	C-1K312	• Piston					1
16	C-VG122.061008	• Screw					1
17	C-VI131.1010	• Nipple, Grease					3

DASH (-) ITEM NOT ILLUSTRATED



**MODEL XXT 32 TRUCK MOUNTED
CONCRETE BOOM PUMP
ILLUSTRATED PARTS MANUAL**

**XXT 32
PARTS
GROUP 70
FIGURE 12
PAGE 01**

THIS PAGE INTENTIONALLY LEFT BLANK.

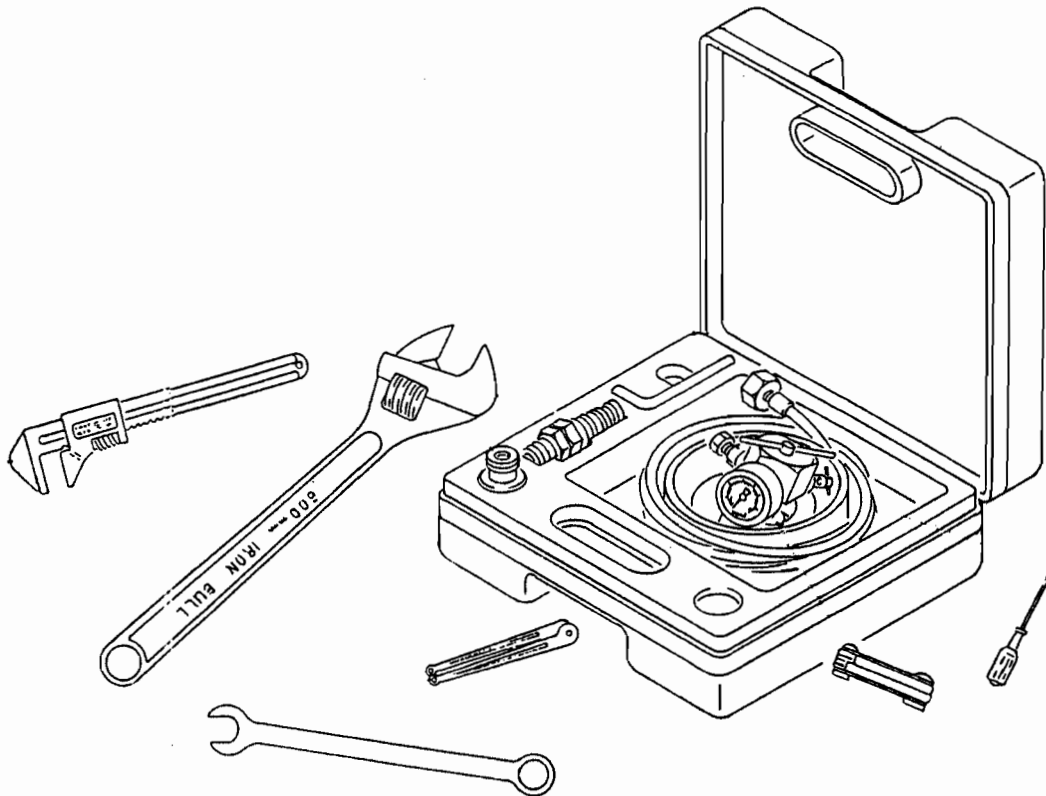

REED TRUCK MOUNTED CONCRETE BOOM PUMP MODEL XXT 32 ILLUSTRATED PARTS MANUAL GROUP 80 OPTIONAL INSTALLATION CONTAINS THE FOLLOWING FIGURES:

- | | |
|------------------|-----------------------------------|
| FIGURE 00 | TABLE OF CONTENTS |
| FIGURE 01 | OPTIONAL INSTALLATION |
| FIGURE 02 | ACCUMULATOR CHARGE KIT |
| FIGURE 03 | OPTIONAL TOOL KIT ASSEMBLY |

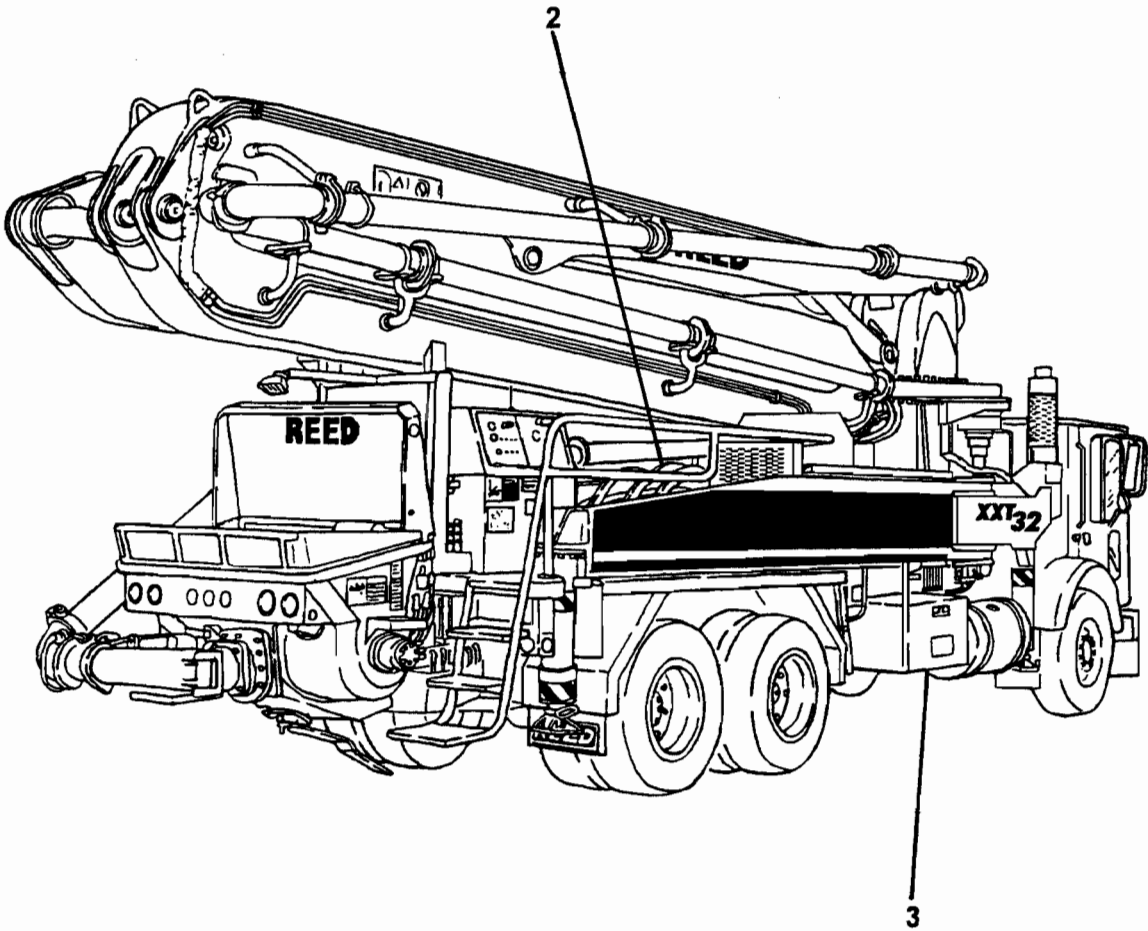



OPTIONAL INSTALLATION

XXT 32
PARTS
GROUP 80
FIGURE 01
PAGE 02

ITEM NO.	REED'S PARTS NO.	DESCRIPTION	QTY
-1	80-01	Installation, Optional (See Group 10, Figure 01 for NHA)	Ref
2	71460	• Kit, Accumulator Charge (See Group 80, Figure 04 for DET)	1
3	79020	• Assembly, Optional Tool Kit (See Group 80, Figure 06 for DET)	1

DASH (-) ITEM NOT ILLUSTRATED



ACCUMULATOR CHARGE KIT

XXT 32
PARTS
GROUP 80
FIGURE 02
PAGE 01

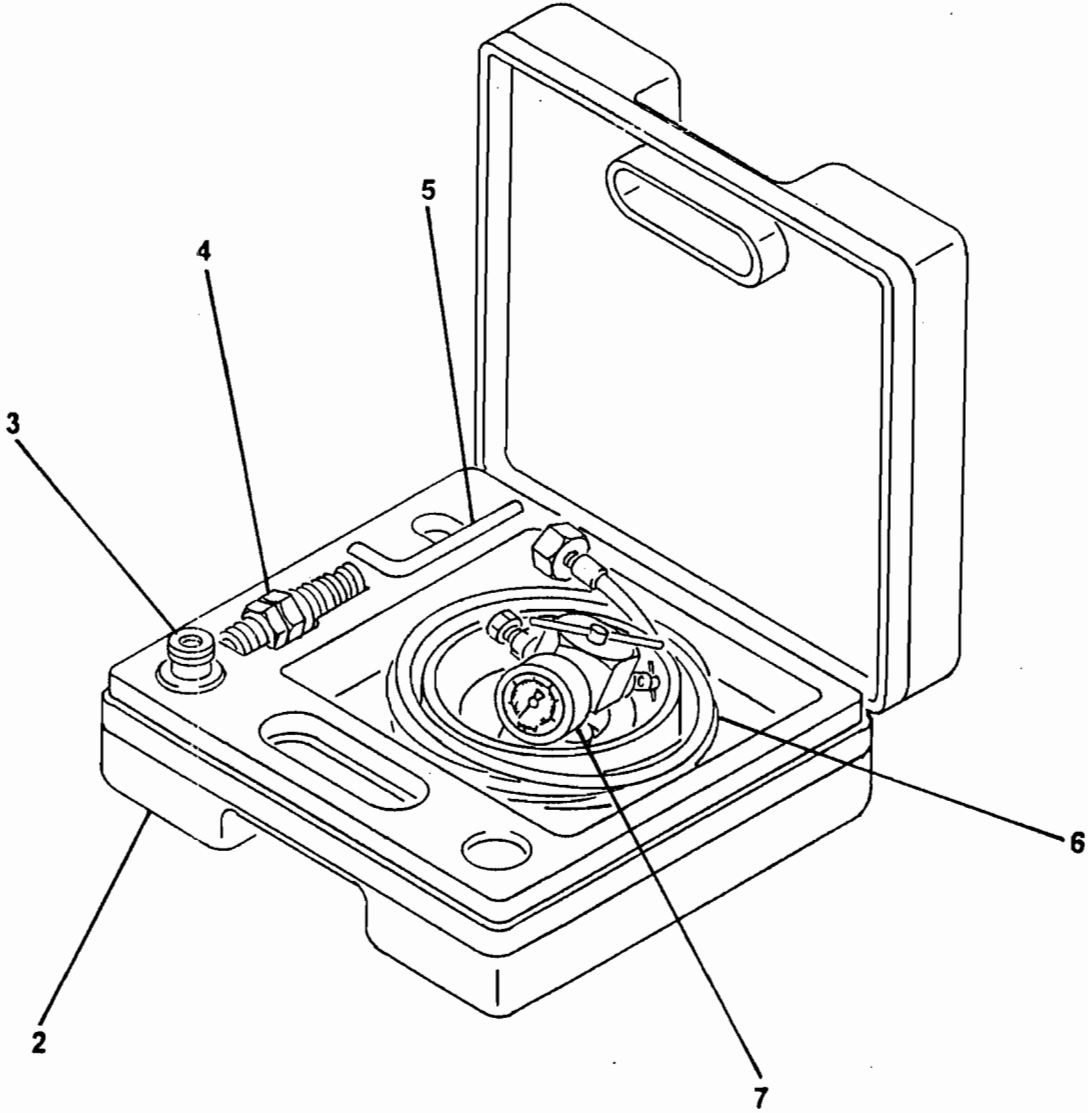



ACCUMULATOR CHARGE KIT

XXT 32
PARTS
GROUP 80
FIGURE 02
PAGE 02

ITEM NO.	REED'S PARTS NO.	DESCRIPTION					QTY
		1	2	3	4	5	
-1	71460	Kit, Accumulator Charge (See Group 80, Figure 01 for NHA)					Ref
2		• Case, Charge Kit					1
3		• Adapter, FPK / SB					1
4		• Adapter, G4					1
5		• Wrench, Allen					1
6		• Hose, Charging					1
7		• Unit, FPK Charging and Gagging					1

DASH (-) ITEM NOT ILLUSTRATED

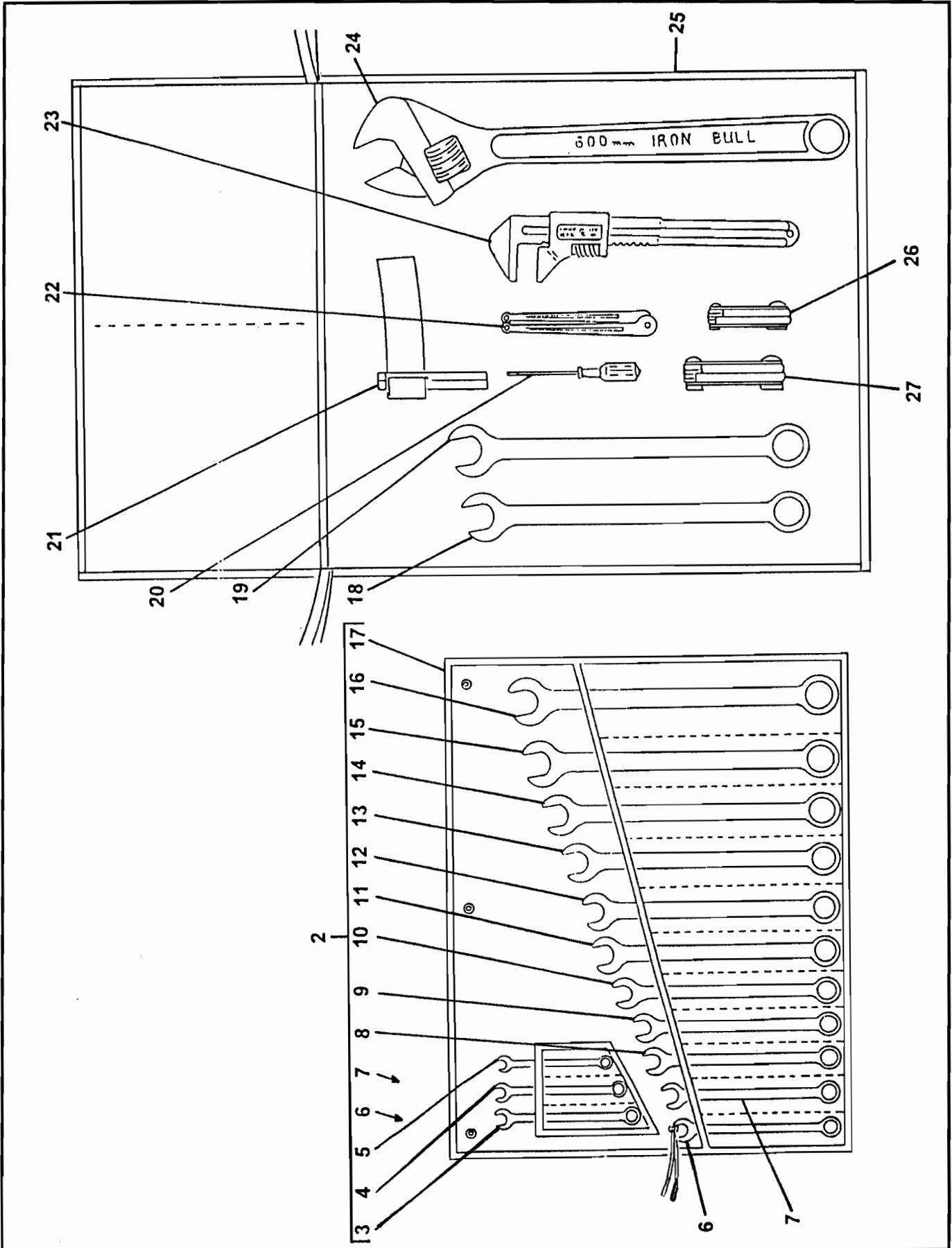



OPTIONAL TOOL KIT ASSEMBLY

XXT 32
PARTS
GROUP 80
FIGURE 03
PAGE 02

ITEM NO.	REED'S PARTS NO.	DESCRIPTION					QTY
		1	2	3	4	5	
-1	79020	Assembly, Optional Tool Kit (See Group 80, Figure 01 for NHA)					Ref
2	79037	• Kit, Wrench					1
3		• • Wrench, 1/2 Inch					1
4		• • Wrench, 7/16 Inch					1
5		• • Wrench, 3/8 Inch					1
6		• • Wrench, 9/16 Inch					1
7		• • Wrench, 5/8 Inch					1
8		• • Wrench, 11/16 Inch					1
9		• • Wrench, 3/4 Inch					1
10		• • Wrench, 13/16 Inch					1
11		• • Wrench, 7/8 Inch					1
12		• • Wrench, 15/16 Inch					1
13		• • Wrench, 1 Inch					1
14		• • Wrench, 1-1/16 Inch					1
15		• • Wrench, 1-1/8 Inch					1
16		• • Wrench, 1-1/4 Inch					1
17		• • Wrap, Plastic					1
18	79036	• Wrench, 1-3/8 Inch					1
19	79028	• Wrench, 1-1/2 Inch					1
20	79038	• Screwdriver					1
21	79814	• Wrench, Strap (for Filter)					1
22	79325	• Wrench, Spanner					1
23	79031	• Wrench, Monkey					1
24	79032	• Wrench, Adjustable 24 Inch					1
25	77502	• Bag, Tool					1
26	79030	• Set, Metric Allen Key (2-8 mm)					1
27	79029	• Set, Standard Allen Key (3/16-3/8 Inch)					1

DASH (-) ITEM NOT ILLUSTRATED



**MODEL XXT 32 TRUCK MOUNTED
CONCRETE BOOM PUMP
ILLUSTRATED PARTS MANUAL**

**XXT 32
PARTS
GROUP 80
FIGURE 04
PAGE 01**

THIS PAGE INTENTIONALLY LEFT BLANK.

REED TRUCK MOUNTED CONCRETE BOOM PUMP MODEL **XXT 32**
ILLUSTRATED PARTS MANUAL GROUP 90 BOOM INSTALLATION CONTAINS
THE FOLLOWING FIGURES:

- FIGURE 00** TABLE OF CONTENTS
- FIGURE 01** BOOM INSTALLATION
- FIGURE 02** FIRST BOOM ASSEMBLY
- FIGURE 03** SECOND BOOM ASSEMBLY
- FIGURE 04** THIRD BOOM ASSEMBLY
- FIGURE 05** FOURTH BOOM ASSEMBLY
- FIGURE 06** FIRST BOOM CYLINDER ASSEMBLY
- FIGURE 07** SECOND BOOM CYLINDER ASSEMBLY
- FIGURE 08** THIRD BOOM CYLINDER ASSEMBLY
- FIGURE 09** FOURTH BOOM CYLINDER ASSEMBLY
- FIGURE 10** CONCRETE PIPELINE ASSEMBLY (DECK AREA)
- FIGURE 11** CONCRETE PIPELINE ASSEMBLY (BOOM AREA)

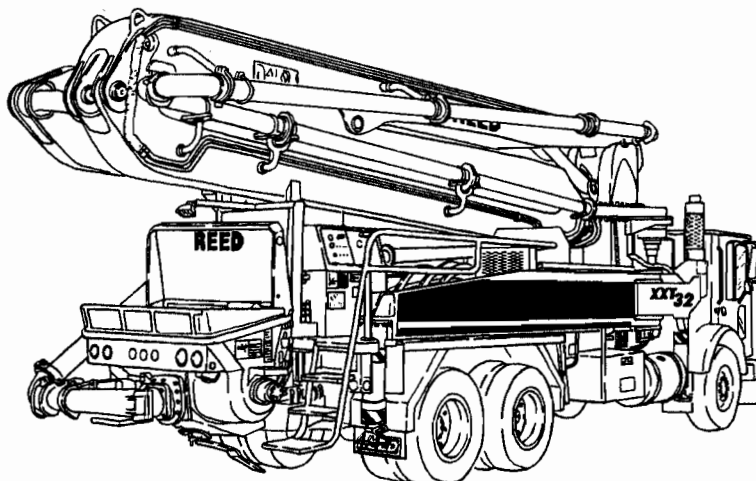



BOOM INSTALLATION

XXT 32
PARTS
GROUP 90
FIGURE 01
PAGE 01

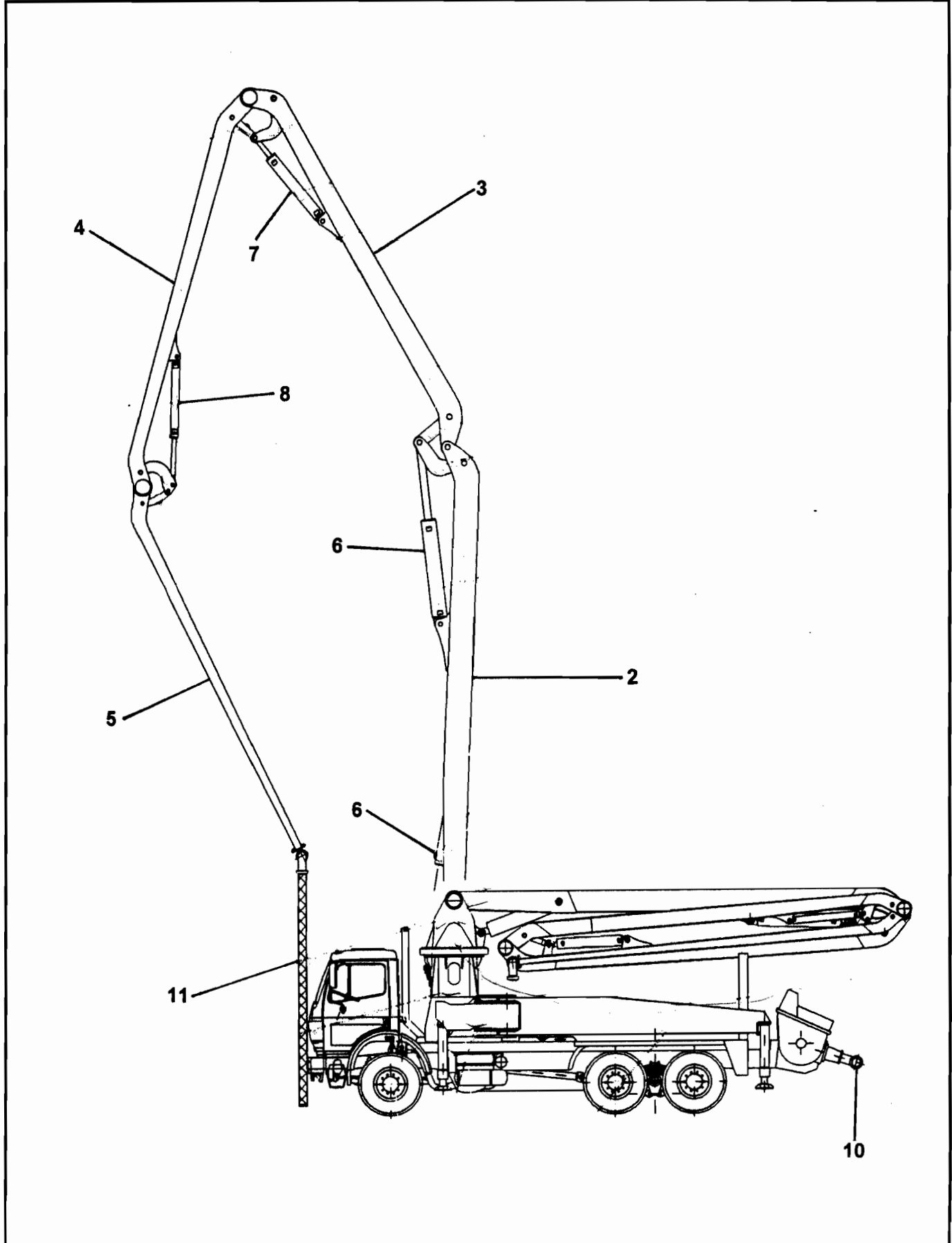

REVISION:



BOOM INSTALLATION

XXT 32
PARTS
GROUP 90
FIGURE 01
PAGE 02

ITEM NO.	REED'S PARTS NO.	DESCRIPTION					QTY
		1	2	3	4	5	
-1	90-01	Installation, Boom (See Group 10, Figure 01 for NHA)					Ref
2	C-3A1	• Assembly, First Boom (See Group 90, Figure 02 for DET)					1
3	C-3A2	• Assembly, Second Boom (See Group 90, Figure 03 for DET)					1
4	C-3A3	• Assembly, Third Boom (See Group 90, Figure 04 for DET)					1
5	C-3A4	• Assembly, Fourth Boom (See Group 90, Figure 05 for DET)					1
6	C-3B1A	• Assembly, First Boom Cylinder (See Group 90, Figure 06 for DET)					1
7	C-3B2A	• Assembly, Second Boom Cylinder (See Group 90, Figure 07 for DET)					1
8	C-5B3C	• Assembly, Third Boom Cylinder (See Group 90, Figure 08 for DET)					1
9	C-3B4C	• Assembly, Fourth Boom Cylinder (See Group 90, Figure 09 for DET)					1
10	90-10	• Assembly, Concrete Pipe Line (Deck Area) (See Group 90, Figure 10 for DET)					1
11	C-3T	• Assembly, Concrete Pipe Line (Boom Area) (See Group 90, Figure 11 for DET)					1

DASH (-) ITEM NOT ILLUSTRATED

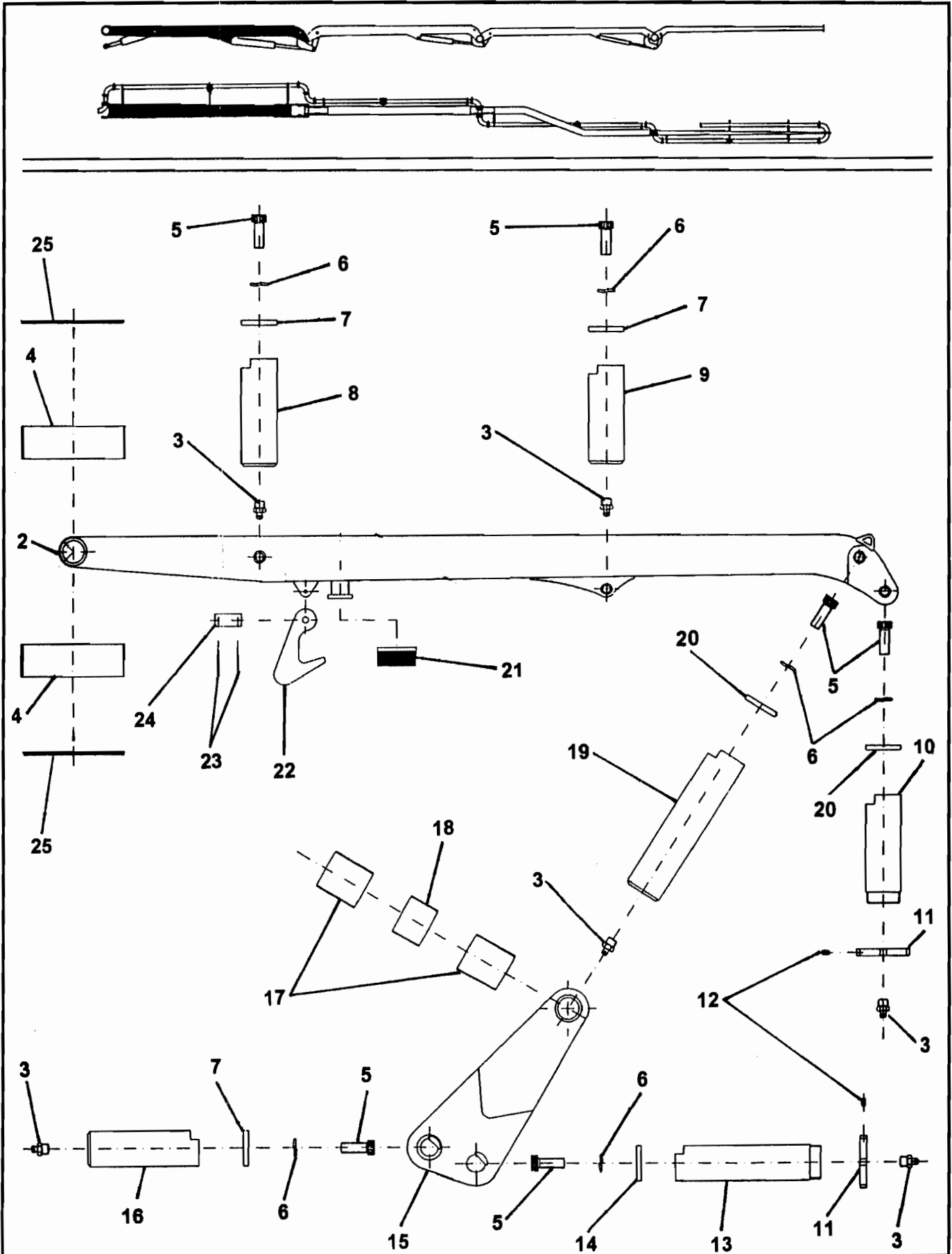

REVISION:

ITEM NO.	REED'S PARTS NO.	DESCRIPTION					QTY
		1	2	3	4	5	
-1	C-3A1	Assembly, First Boom (See Group 90, Figure 01 for NHA)					Ref
2	C-3A101	• Structure, Base					1
3	C-VI131.1010	• Nipple, Grease					7
4	C-CD230.235070	• Bearing, Anti-friction					2
5	C-VC110.101525	• Screw					7
6	C-UE110.10	• Washer, Elastic					7
7	C-UD080.1106	• Washer, Pin Locking					3
8	C-3P115	• Pin					1
9	C-3P114	• Pin					1
10	C-3P113	• Pin					2
11	C-GV075.2015	• Ring, Thread					3
12	C-VG120.061010	• Screw					4
13	C-3P110	• Pin					1
14	C-UD080.1106	• Washer, Pin Locking					1
15	C-3C101	• Beam					1
16	C-3P112	• Pin					1
17	C-CD090.095060	• Bearing, Anti-friction					2
18	C-3C102	• Piece, Distance					1
19	C-3P111	• Pin					1
20	C-UD090.1106	• Washer, Pin Locking					3
21	C-UG220.10012	• Pad, Rubber					1
22	C-4A103	• Hook					1
23	C-VS110.04050	• Pin, Split					2
24	C-4P120	• Pin					1
25	C-CR230.02	• Ring, Wear					2

DASH (-) ITEM NOT ILLUSTRATED



SECOND BOOM ASSEMBLY

XXT 32
PARTS
GROUP 90
FIGURE 03
PAGE 01

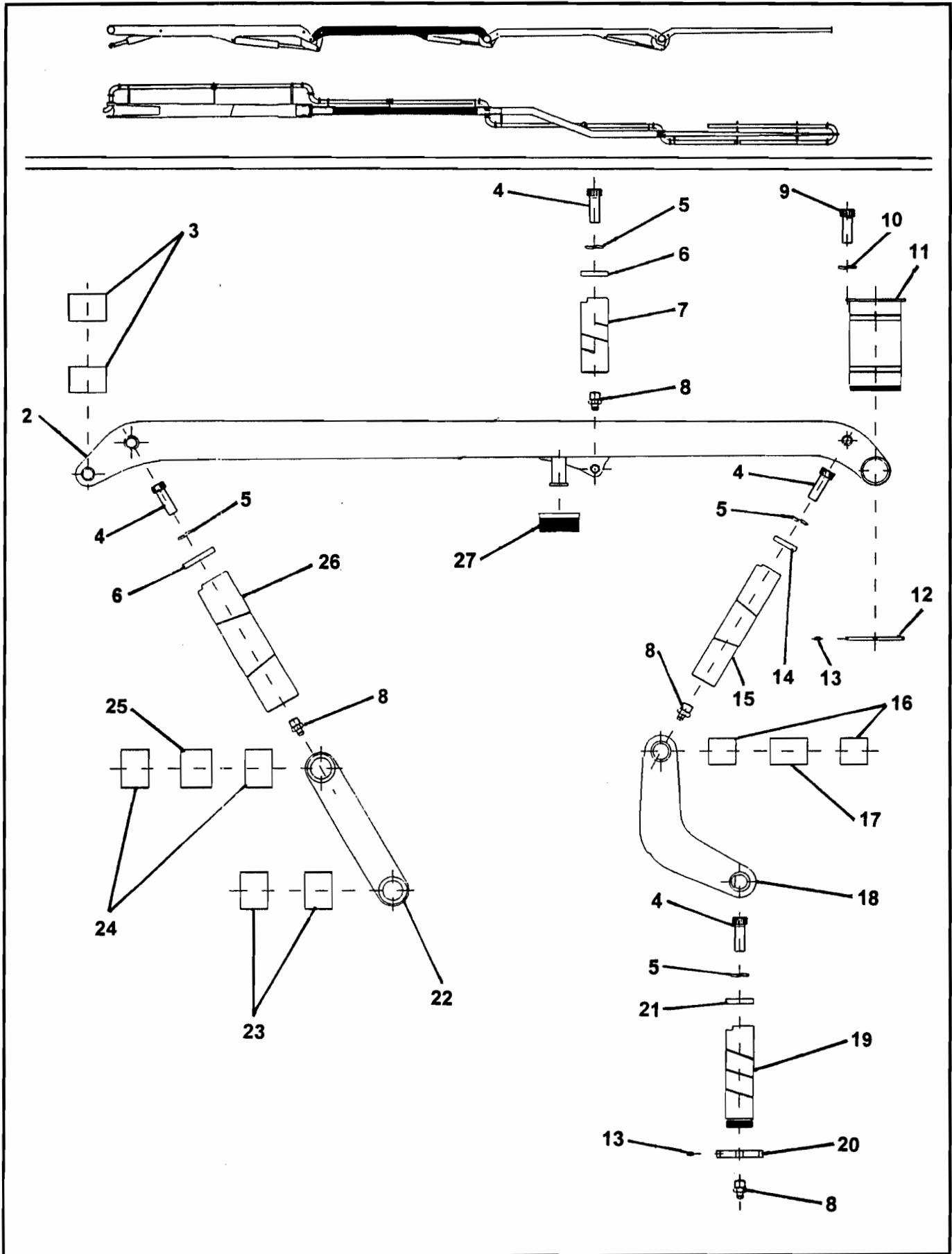

REVISION:

ITEM NO.	REED'S PARTS NO.	DESCRIPTION					QTY
		1	2	3	4	5	
-1	C-3A2	Assembly, Second Boom (See Group 90, Figure 01 for NHA)					Ref
2	C-3A201A	• Structure, Base					1
3	C-CD090.095060	• Bearing, Anti-friction					2
4	C-VC110.101525	• Screw					4
5	C-UE110.10	• Washer, Elastic					4
6	C-UD080.1106	• Washer, Pin Locking					2
7	C-3P108	• Pin					1
8	C-VI131.1010	• Nipple, Grease					4
9	C-VC110.081220	• Screw					4
10	C-UE110.08	• Washer, Elastic					4
11	C-3P107C	• Pin					1
12	C-GV218.2015	• Ring, Thread					1
13	C-VG122.061010	• Screw					4
14	C-UD065.1105	• Washer, Pin Locking					1
15	C-3P106	• Pin					1
16	C-CD070.075050	• Bearing, Anti-friction					2
17	C-3C202	• Piece, Distance					1
18	C-3C201	• Beam					1
19	C-3P105	• Pin					1
20	C-GV055.1515	• Ring, Thread					1
21	C-UD060.1105	• Washer, Pin Locking					1
22	C-3D101	• Rod, Connecting					1
23	C-CD080.085060	• Bearing, Anti-friction					2
24	C-CD085.090060	• Bearing, Anti-friction					2
25	C-3D102	• Piece, Distance					1
26	C-3P109	• Pin					1
27	C-UG220.10012	• Pad, Rubber					1

DASH (-) ITEM NOT ILLUSTRATED

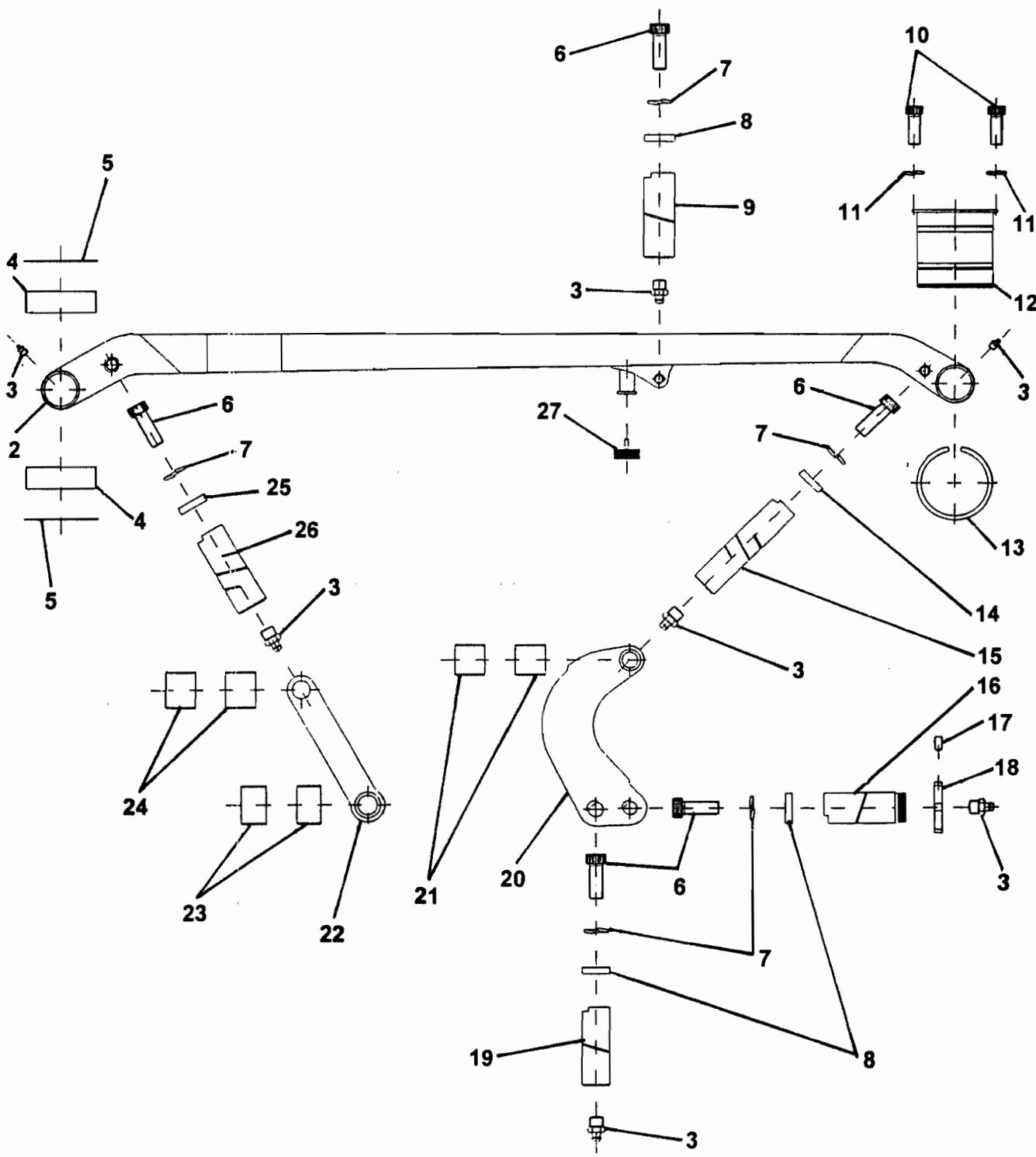
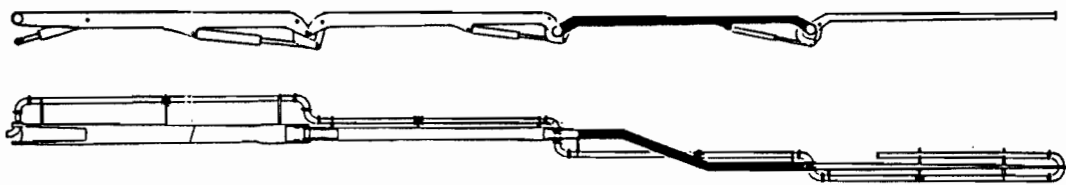

ITEM NO.	REED'S PARTS NO.	DESCRIPTION					QTY
		1	2	3	4	5	
-1	C-3A3	Assembly, Third Boom (See Group 90, Figure 01 for NHA)					Ref
2	C-3A301A	• Structure, Base					1
3	C-VI131.1010	• Nipple, Grease					9
4	C-CD220.225035	• Bearing, Anti-friction					2
5	C-CR220.02	• Ring, Wear					2
6	C-VC110.101525	• Screw					5
7	C-UE110.10	• Washer, Elastic					5
8	C-UD050.1105	• Washer, Pin Locking					3
9	C-4P106	• Pin					1
10	C-VC110.081220	• Screw					8
11	C-UE110.08	• Washer, Elastic					8
12	C-4P105B	• Pin					2
13	C-AA210.220	• Ring, Clamping					2
14	C-UD055.1105	• Washer, Pin Locking					1
15	C-4P107	• Pin					1
16	C-3P103	• Pin					1
17	C-VG122.061010	• Screw					2
18	C-GV045.1512	• Ring, Threaded					1
19	C-3P102	• Pin					1
20	C-6C301A	• Beam					1
21	C-CD055.060060	• Bearing, Anti-friction					2
22	C-3D201	• Rod, Connecting					1
23	C-CD060.065040	• Bearing, Anti-friction					2
24	C-CD065.075050	• Bearing, Anti-friction					1
25	C-UD065.1105	• Washer, Pin Locking					1
26	C-3P104	• Pin					1
27	UG220.10012	• Pad, Rubber					1

DASH (-) ITEM NOT ILLUSTRATED

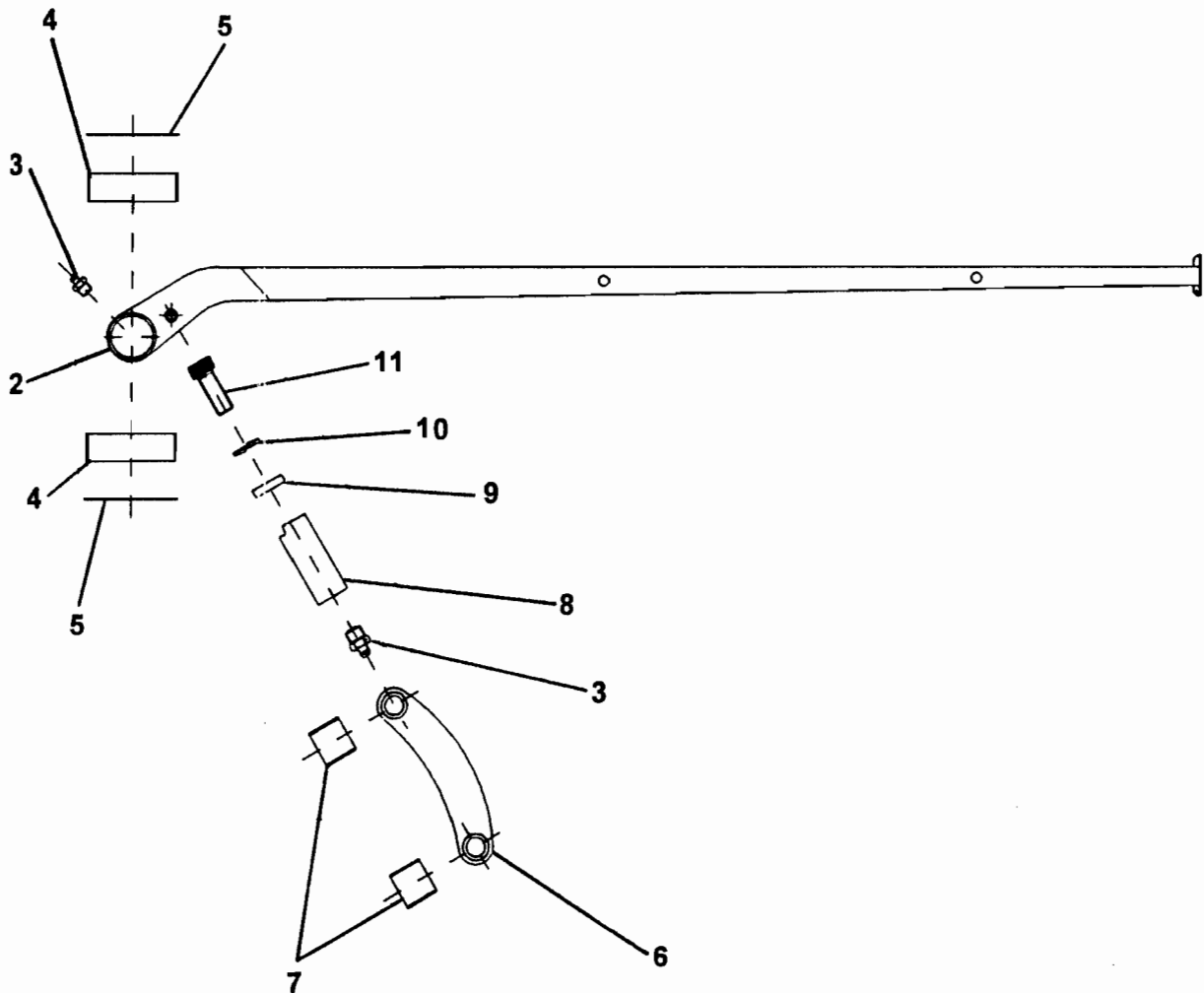
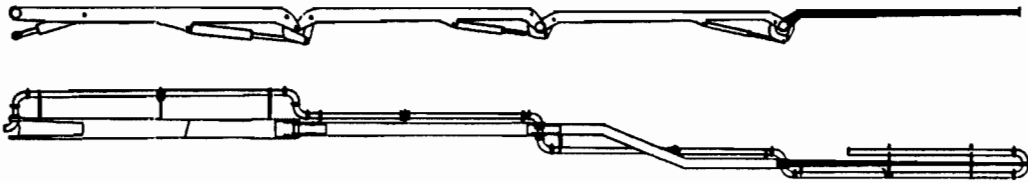



FOURTH BOOM ASSEMBLY

XXT 32
PARTS
GROUP 90
FIGURE 05
PAGE 02

ITEM NO.	REED'S PARTS NO.	DESCRIPTION					QTY
		1	2	3	4	5	
-1	C-3A4	Assembly, Fourth Boom (See Group 90, Figure 01 for NHA)					Ref
2	C-3A401A	• Structure, Base					1
3	C-VI131.1010	• Nipple, Grease					3
4	C-CD220.225030	• Bearing, Anti-friction					2
5	C-CR220.02	• Ring, Wear					2
6	C-3D301A	• Rod, Connection					1
7	C-CD050.055050	• Bearing, Anti-friction					2
8	C-3P101	• Pin					1
9	C-UD050.1105	• Washer, Pin Locking					1
10	C-UE110.10	• Washer, Elastic					1
11	C-VC110.101525	• Screw					1

DASH (-) ITEM NOT ILLUSTRATED

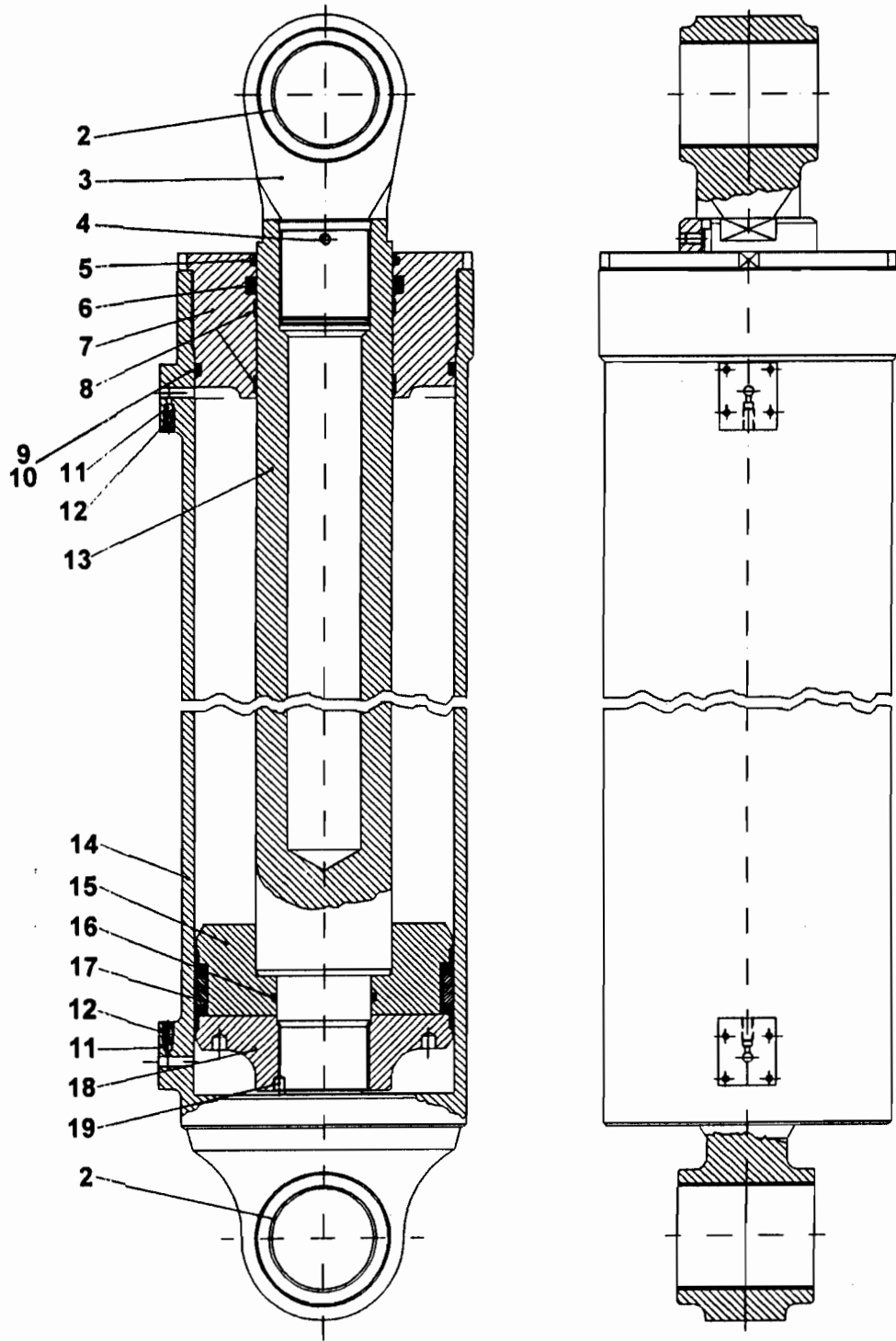
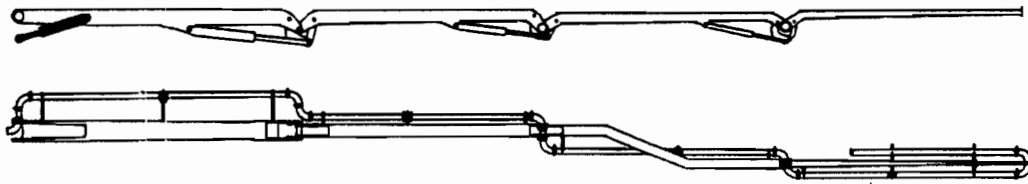

ITEM NO.	REED'S PARTS NO.	DESCRIPTION					QTY
		1	2	3	4	5	
-1	C-3B1A	Assembly, First Boom Cylinder (See Group 90, Figure 01 for NHA)					Ref
2	C-CD080.085060	• Bearing, Anti Friction					4
3	C-3B108A	• Cap, Rod					1
4	C-VG122.101515	• Screw					1
5	C-BR310.120	• Gasket, Seal					1
6	C-BT110.120	• Gasket, Seal					1
7	C-3B101	• Head, Slide Rod					1
8	C-AG123.120	• Ring, Slide Rod					2
9	C-AO120.371	• Ring, Sealing					1
10	C-AP110.372	• Seal, Gasket					1
11	C-CS100.007	• Ball, Still					2
12	C-WPVS1	• Valve, Air Hole					2
13	C-3B107	• Rod					1
14	C-3B102A	• Cylinder					1
15	C-3B112	• Piston					1
16	C-AO420.6325	• Ring, Sealing					1
17	C-BS229058071A	• Gasket, Seal					1
18	C-3B109A	• Nut, Rod					1
19	C-VG121.101512	• Screw					1

DASH (-) ITEM NOT ILLUSTRATED



SECOND BOOM CYLINDER ASSEMBLY

XXT 32
PARTS
GROUP 90
FIGURE 07
PAGE 01

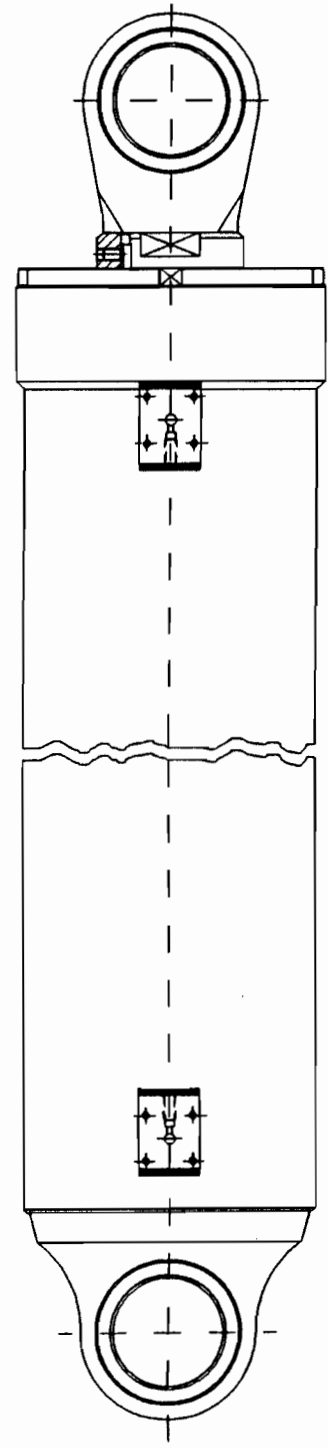
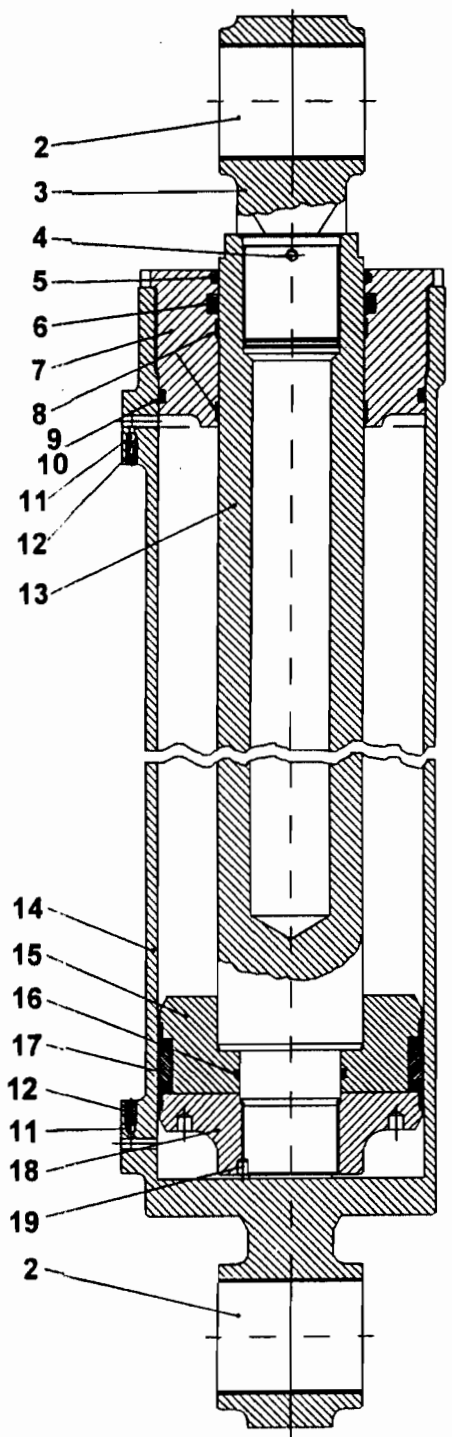
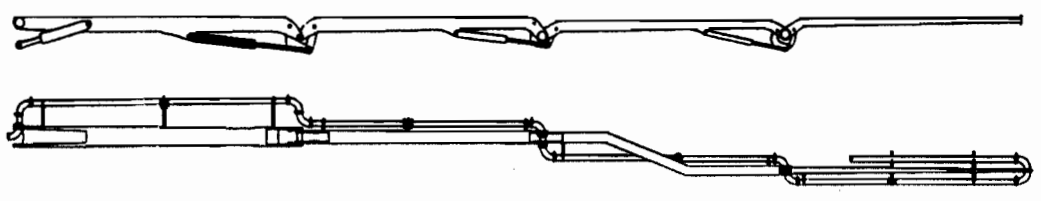

REVISION:

ITEM NO.	REED'S PARTS NO.	DESCRIPTION					QTY
		1	2	3	4	5	
-1	C-3B2A	Assembly, Second Boom Cylinder (See Group 90, Figure 01 for NHA)					Ref
2	C-CD080.085060	• Bearing, Anti Friction					4
3	C-3B208A	• Cap, Rod					1
4	C-VG122.101515	• Screw					1
5	C-BR310.120	• Gasket, Seal					1
6	C-BT110.120	• Gasket, Seal					1
7	C-3B201	• Head, Slide Rod					1
8	C-AG123.120	• Ring, Slide Rod					2
9	C-AO120.368	• Ring, Sealing					1
10	C-AP110.368	• Seal, Gasket					1
11	C-CS100.007	• Ball, Steel					2
12	C-WPVS1	• Valve, Air Hole					2
13	C-3B207	• Rod					1
14	C-3B202A	• Cylinder					1
15	C-3B212	• Piston					1
16	C-AO420.6325	• Ring, Sealing					1
17	C-BS228267281A	• Ring, Sealing					1
18	C-3B209A	• Nut, Rod					1
19	C-VG121.101512	• Screw					1

DASH (-) ITEM NOT ILLUSTRATED

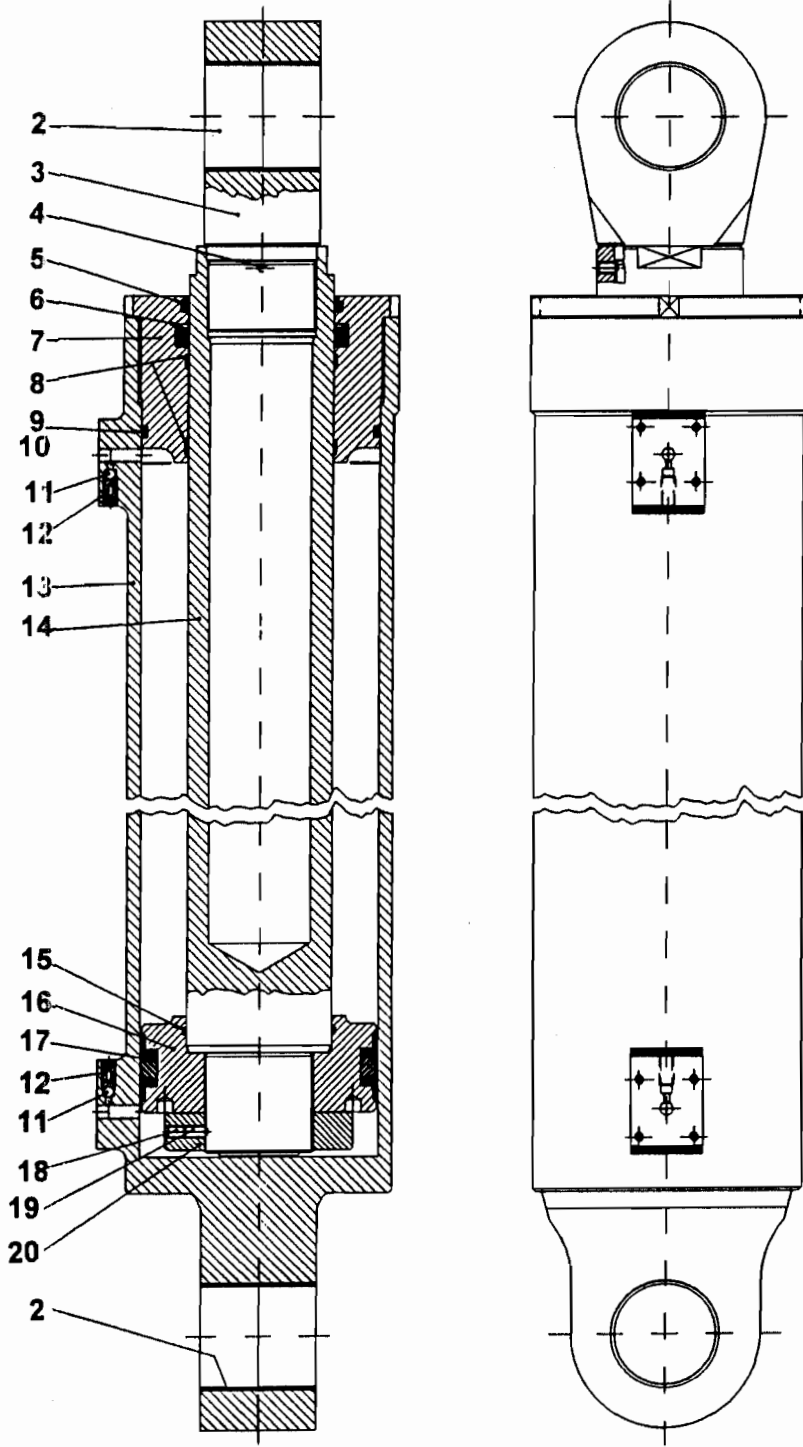
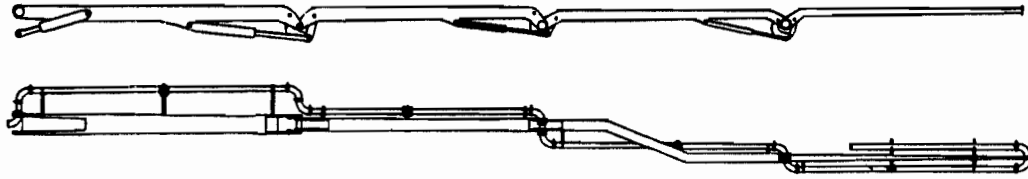

ITEM NO.	REED'S PARTS NO.	DESCRIPTION					QTY
		1	2	3	4	5	
-1	C-5B3C	Assembly, Third Boom Cylinder (See Group 90, Figure 01 for NHA)					Ref
2	C-CD065.070060	• Bearing, Anti Friction					4
3	C-5B308	• Cap, Rod					1
4	C-VG122.081215	• Screw					1
5	C-BR310.080	• Gasket, Seal					1
6	C-BT110.080	• Gasket, Seal					1
7	C-3B301	• Head, Slide Rod					1
8	C-AG122.080	• Ring, Slide Rod					2
9	C-AP110.361	• Seal, Gasket					1
10	C-AO120.361	• Ring, Sealing					1
11	C-CS100.007	• Ball, Steel					2
12	C-WPVS1	• Valve, Air Hole					2
13	C-5B302B	• Cylinder					1
14	C-3B307A	• Rod					1
15	C-AO420.4312	• Ring, Seal					1
16	C-3B312C	• Piston					1
17	C-BS23649551	• Gasket, Seal					1
18	C-VG122.081212	• Screw					1
19	C-VG122.081215	• Screw					1
20	C-3B309	• Nut, Rod					1

DASH (-) ITEM NOT ILLUSTRATED

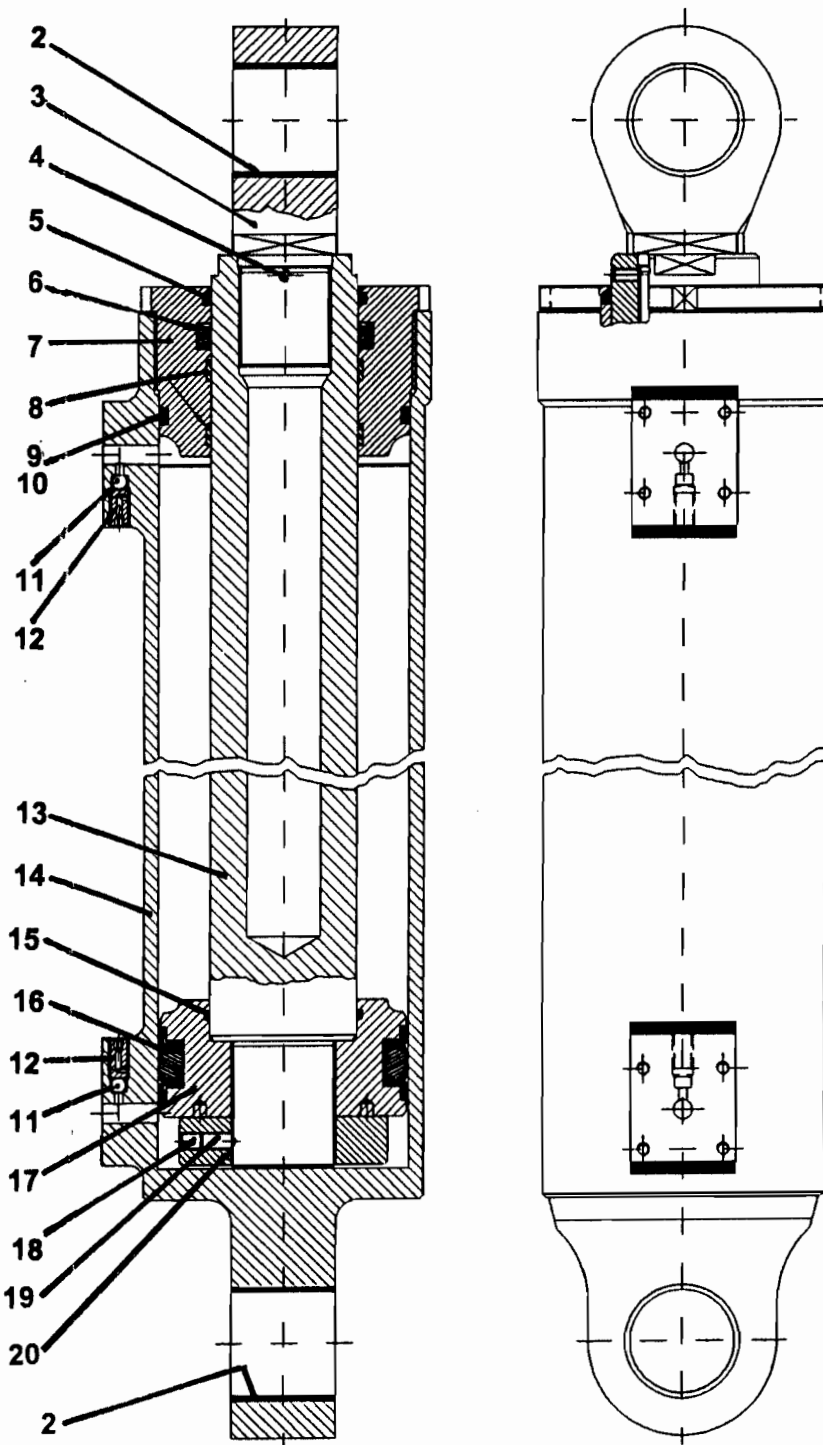
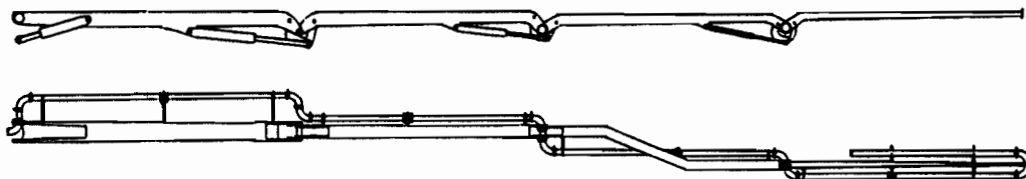

ITEM NO.	REED'S PARTS NO.	DESCRIPTION					QTY
		1	2	3	4	5	
-1	C-3B4C	Assembly, Fourth Boom Cylinder (See Group 90, Figure 01 for NHA)					Ref
2	C-CD050.055050	• Bearing, Anti Friction					4
3	C-3B408A	• Cap, Rod					4
4	C-VG122.061012	• Screw					1
5	C-BR310.070	• Gasket, Seal					1
6	C-BT110.070	• Gasket, Seal					1
7	C-3B401	• Head, Slide Rod					1
8	C-AG122.070	• Ring, Slide Rod					2
9	C-AP110.348	• Seal, Gasket					1
10	C-AO120.348	• Ring, Sealing					1
11	C-CS100.007	• Ball, Steel					2
12	C-WPVS1	• Valve, Air Hole					2
13	C-3B407B	• Rod					1
14	C-3B402B	• Cylinder					1
15	C-AO420.4275	• Ring, Sealing					1
16	C-BS23472374	• Gasket, Seal					1
17	C-3B412B	• Piston					1
18	C-VG121.081210	• Screw					1
19	C-VG121.081215	• Screw					1
20	C-3B409	• Nut, Rod					1

DASH (-) ITEM NOT ILLUSTRATED

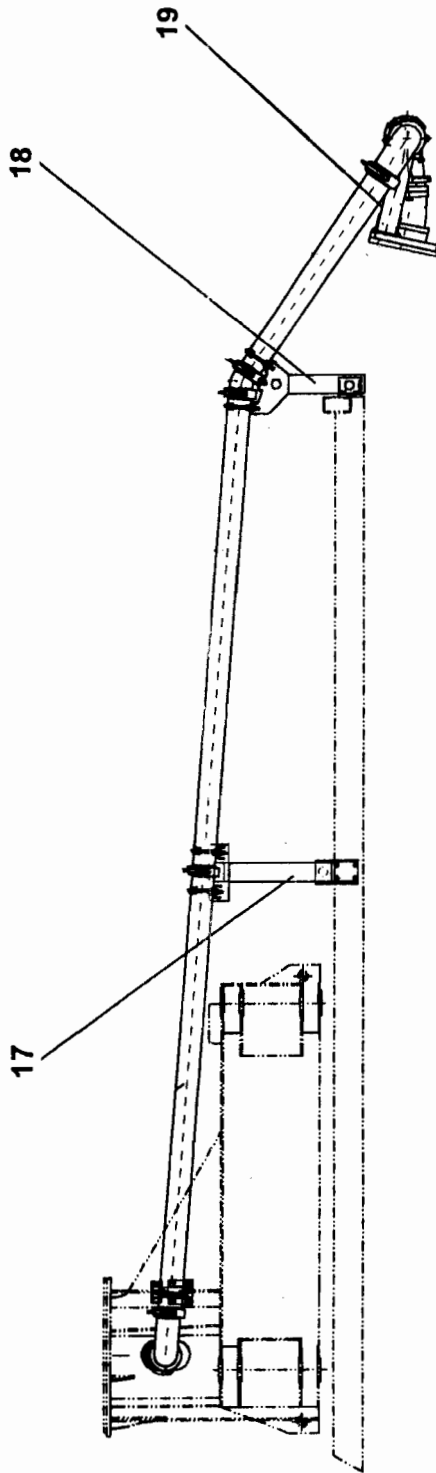

HOPPER OUTLET ASSEMBLY
(SEE GROUP 20, FIGURE 07 FOR REF)

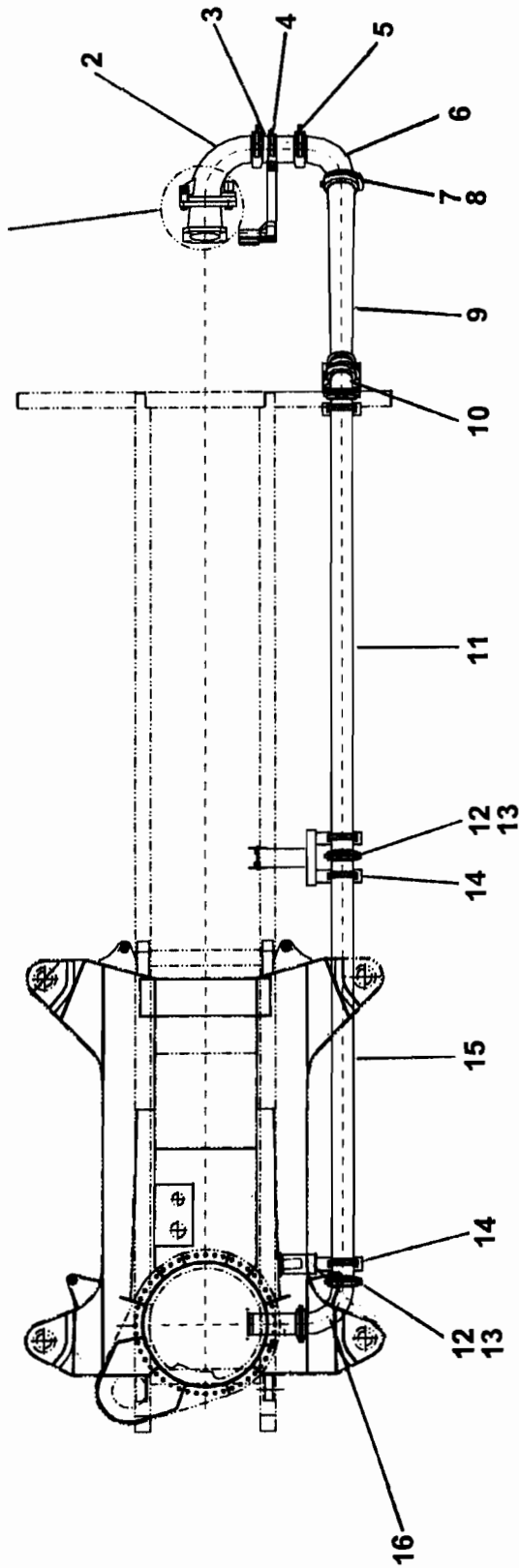

ITEM NO.	REED'S PARTS NO.	DESCRIPTION					QTY
		1	2	3	4	5	
-1	90-10	Assembly, Deck Area Concrete Pipe Line (See Group 90, Figure 01 for NHA)					Ref
2	B-191015	• Elbow, Swing Away					1
3	801076	• Adapter, 6 Inch Special					1
4	B-194053	• Adapter, Snap Coupling					1
5	W-105165	• Adapter, Hopper Snap Coupling					1
6	800336	• Elbow, 6 Inch 90					1
7	W-101779	• Coupling, 6 Inch Clamp					2
8	72241	• Gasket, 6 Inch Clamp					2
9	800326	• Reducer, 6 Inch to 5 Inch					1
10	800328	• Elbow, 5 Inch 30					1
11	800323	• Pipe, 5 Inch Deck					1
12	800070	• Coupling, 5 Inch Snap					5
13	800337	• Gasket, Metric Coupling					5
14	800341	• U-Clamp, 5 Inch Pipe					1
15		• Pipe, 5 Inch Deck					1
16	800327	• Elbow, 5 Inch 90					1
17	B-194027	• Bracket					1
18	B-194013	• Bracket					1
19	B-194033	• Bracket					1

DASH (-) ITEM NOT ILLUSTRATED

REED

CONCRETE PIPE LINE ASSEMBLY (BOOM AREA)

XXT 32
PARTS
GROUP 90
FIGURE 11
PAGE 01

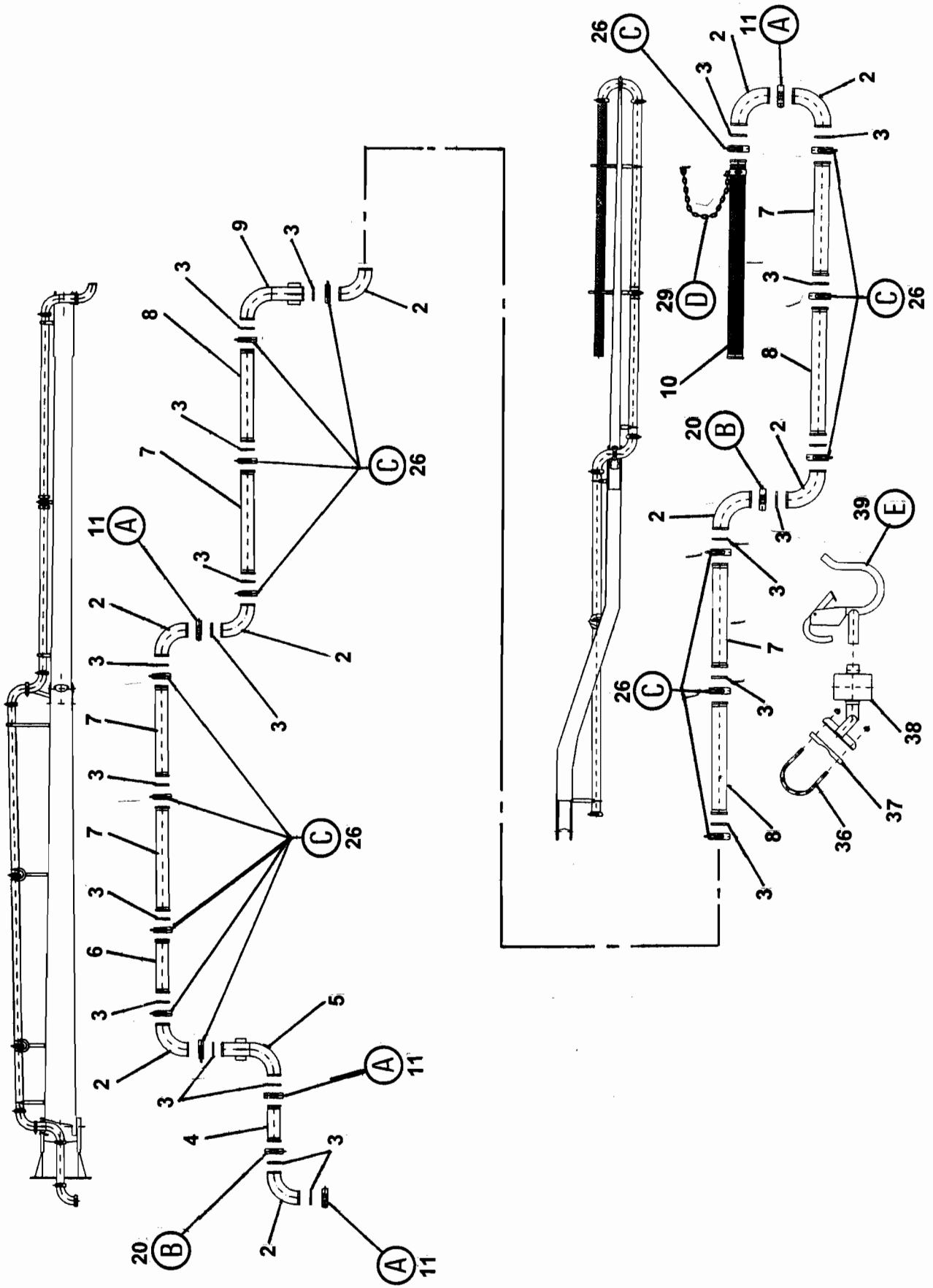

REVISION:

REED**CONCRETE PIPE LINE ASSEMBLY
(BOOM AREA)****XXT 32
PARTS
GROUP 90
FIGURE 11
PAGE 02**

ITEM NO.	REED'S PARTS NO.	DESCRIPTION					QTY
		1	2	3	4	5	
-1	C-3T	Assembly, Boom Area Concrete Pipeline (See Group 90, Figure 01 for NHA)					Ref
2	801100	• Elbow, 90					9
3	C-TB125	• Gasket, Seal					22
4	801105-*	• Pipe					1
5	801102	• Pipe with Bend					1
6	801105-*	• Pipe					1
7	801105-3000	• Pipe					5
8	801105-*	• Pipe					3
9	801103	• Pipe with Bend					1
10	C-TT2.FLEX	• Hose, Flexible Max 4m					1
11	C-TG222	• Coupling, Bracket 2 Bolts					4
20	C-TG221	• Coupling, 2 Bolts					2
26	C-TG211	• Coupling, Lever					16
29	C-TS24	• Kit, Safety Collar					1
36	C-TS212	• Collar					24
37	C-TS001	• Plate, Plastic					24
38	C-VD221.1420	• Nut, Self Locking					48
39	C-TS23	• Kit, Flexible Hose Support					2

* REFER TO SPECIFIC SHEET FOR YOUR MODEL AND SERIAL NUMBER OF UNIT

DASH (-) ITEM NOT ILLUSTRATED

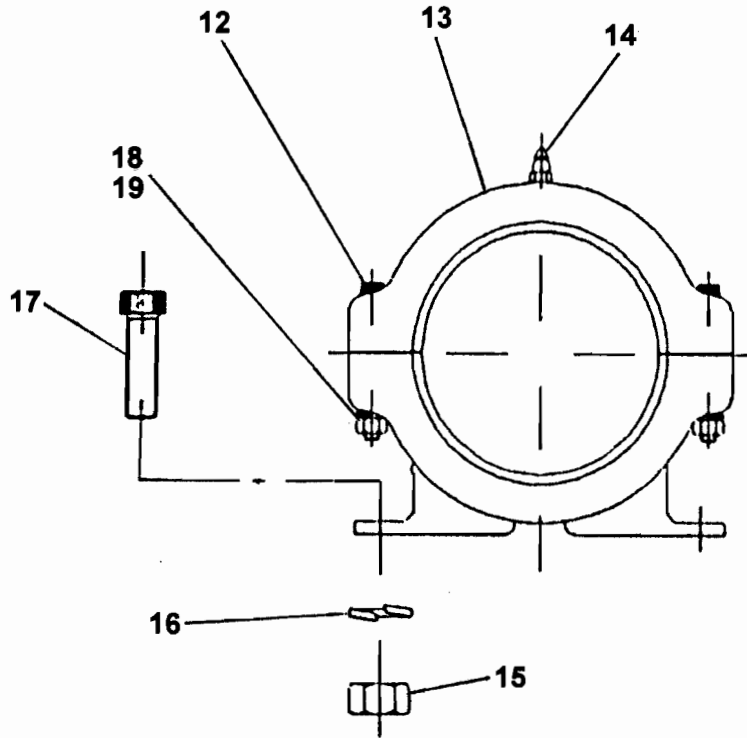

(A)

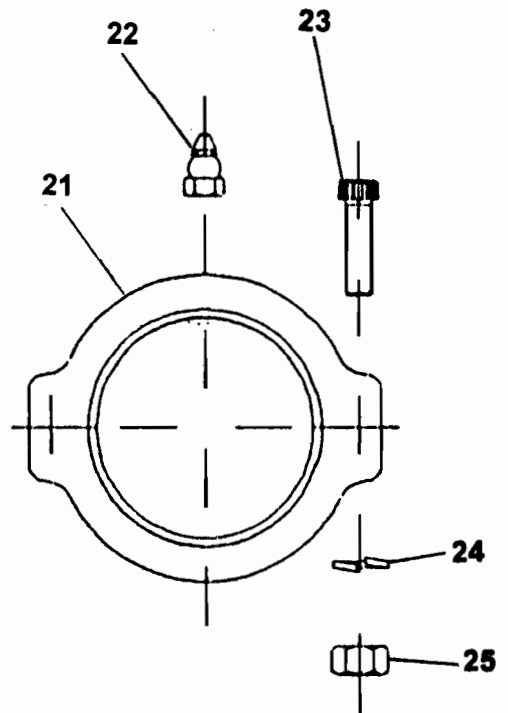

(B)

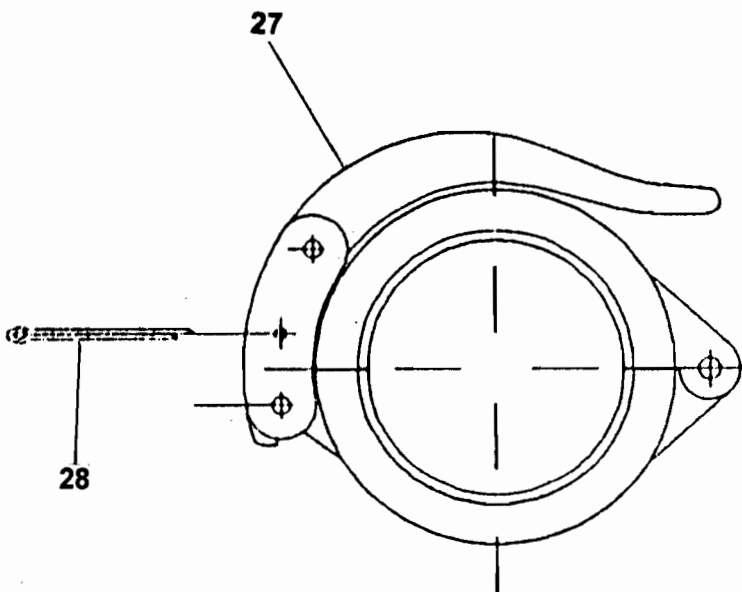

(C)

REED**CONCRETE PIPE LINE ASSEMBLY
(BOOM AREA)****XXT 32
PARTS
GROUP 90
FIGURE 11
PAGE 04**

ITEM NO.	REED'S PARTS NO.	DESCRIPTION					QTY
		1	2	3	4	5	
11	C-TG222	• Coupling, Bracket 2 Bolts					4
12	C-VC112.121755	•• Screw					2
13	C-TG222.01	•• Coupling, Bracket					1
14	C-VI131.1010	•• Nipple, Grease					1
15	C-VD111.1420	•• Nut					2
16	C-UE110.14	•• Washer, Elastic					2
17	C-VC110.142035	•• Screw					2
18	C-UE110.12	•• Washer, Elastic					2
19	C-VD111.1217	•• Nut					2
20	C-TG221	• Coupling, 2 Bolts					2
21	C-TG221.01	•• Coupling					1
22	C-VI131.1010	•• Nipple, Grease					1
23	C-VC110.121755	•• Screw					2
24	C-UE110.12	•• Washer, Elastic					2
25	C-VD111.1217	•• Nut					2
26	C-TG211	• Coupling, Lever					17
27	C-TG211.01	•• Coupling					1
28	C-VS210.08040	•• Pin, Split					1

DASH (-) ITEM NOT ILLUSTRATED

REVISION:

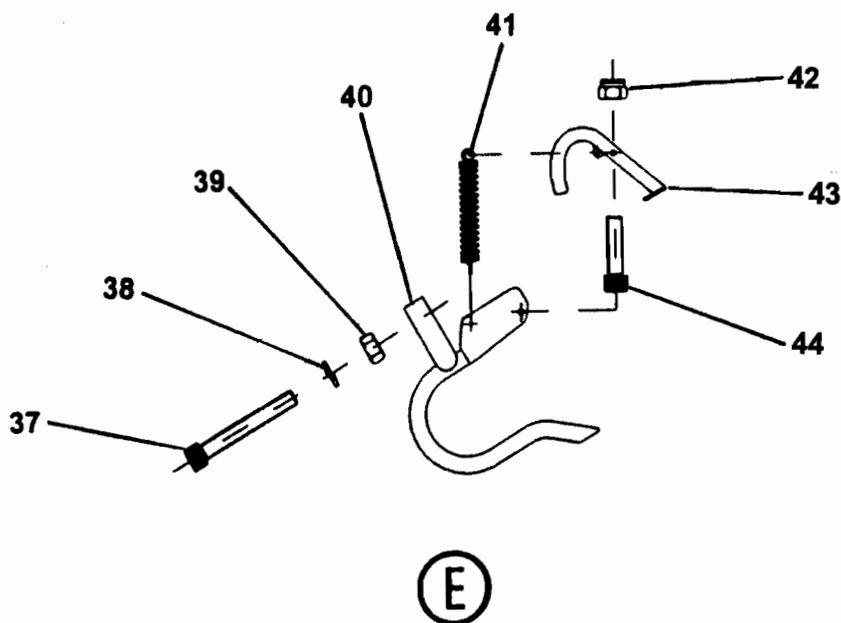
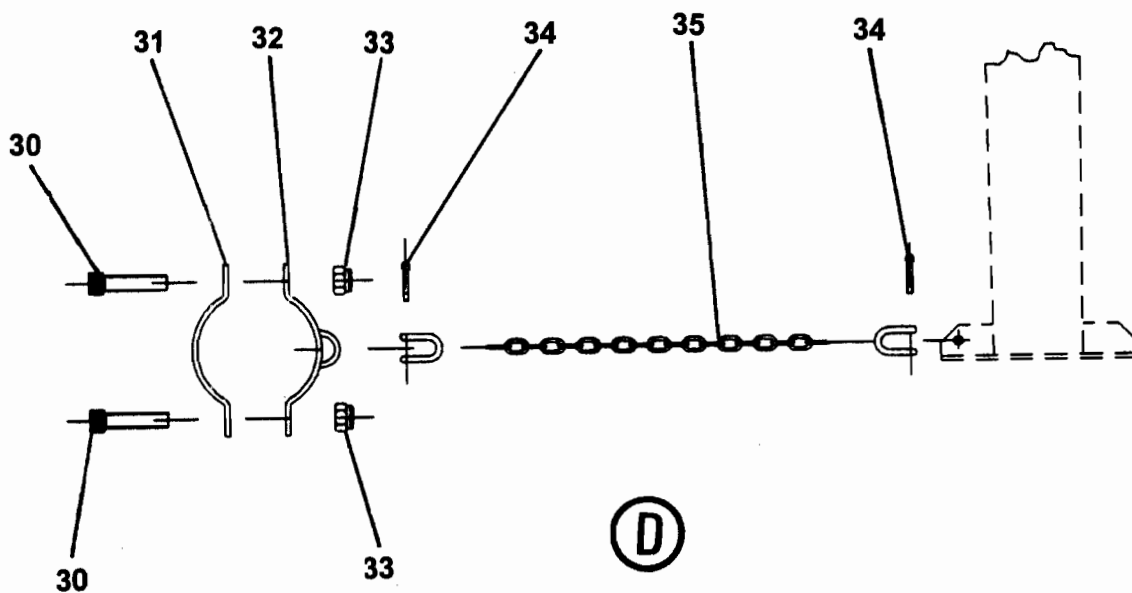



CONCRETE PIPE LINE ASSEMBLY (BOOM AREA)

XXT 32
PARTS
GROUP 90
FIGURE 11
PAGE 06

ITEM NO.	REED'S PARTS NO.	DESCRIPTION					QTY
		1	2	3	4	5	
29	C-TS24	• Kit, Safety Collar					1
30	C-VC110.101560	• • Screw					2
31	C-TS241	• • Collar, Safety					1
32	C-TS242	• • Connecting, Safety Collar					1
33	C-VD221.1015	• • Nut					2
34	C-AC910.1	• • Plate, Shackles Die					2
35	C-TG221	• • Chain Safety					1
36	C-TS23	• Kit, Flexible Hose Support					2
37	C-VC110.081270	• • Screw					1
38	C-UE110.08	• • Washer, Elastic					1
39	C-VD211.0812	• • Nut					1
40	C-TS231	• • Support, Flexible Hose					1
41	C-LT020.015096	• • Spring					1
42	C-VD221.0812	• • Nut, Self Locking					1
43	C-TS232	• • Lever, Locking					1
44	C-VC110.081260	• • Screw					1

DASH (-) ITEM NOT ILLUSTRATED