

CODE NO.	REED'S PARTS NO.	DESCRIPTION	QTY
P1		Front Main Pump – 125 cc	1
P2		Rear Main Pump – 125 cc	1
CYL1	W-104939	Hydraulic Drive Cylinder	2
MAN1	W-104846	Pump Control Manifold	1
SV1		Solenoid Valve – Pump Control	1
		Coil for SV1	2
HP1		HP Limiter Valve	1
PP2		Proportional Pilot Valve	1
MAN2	801114	Manifold – Cylinder Rod Side	2
MAN3	801115	Manifold – Cylinder Bore Side	1
MAN4	801057	Manifold – Pump	3
MAN5	801048	Manifold – Return	1
MAN6	801047	Manifold – Suction	1
FV1		Flushing Valve	1
C1	W-105210	Check Valve – Cylinder Makeup	4
C2	W-105109	Check Valve – Servo Nulling	2
C3	W-105437	Check Valve – Return	1
G1	74562	Pressure Gauge – 6000 psi	1
OC1	800054	Oil Cooler	1
PF1	73300	Pressure Filter	2
	73303	Pressure Filter Element	2
RF1	79245	Return Filter	1
	79269	Return Filter Element	2
G4	79276	Pressure Gauge – Return	1
SS1	801024	Magnetic Suction Strainer – 2"	2

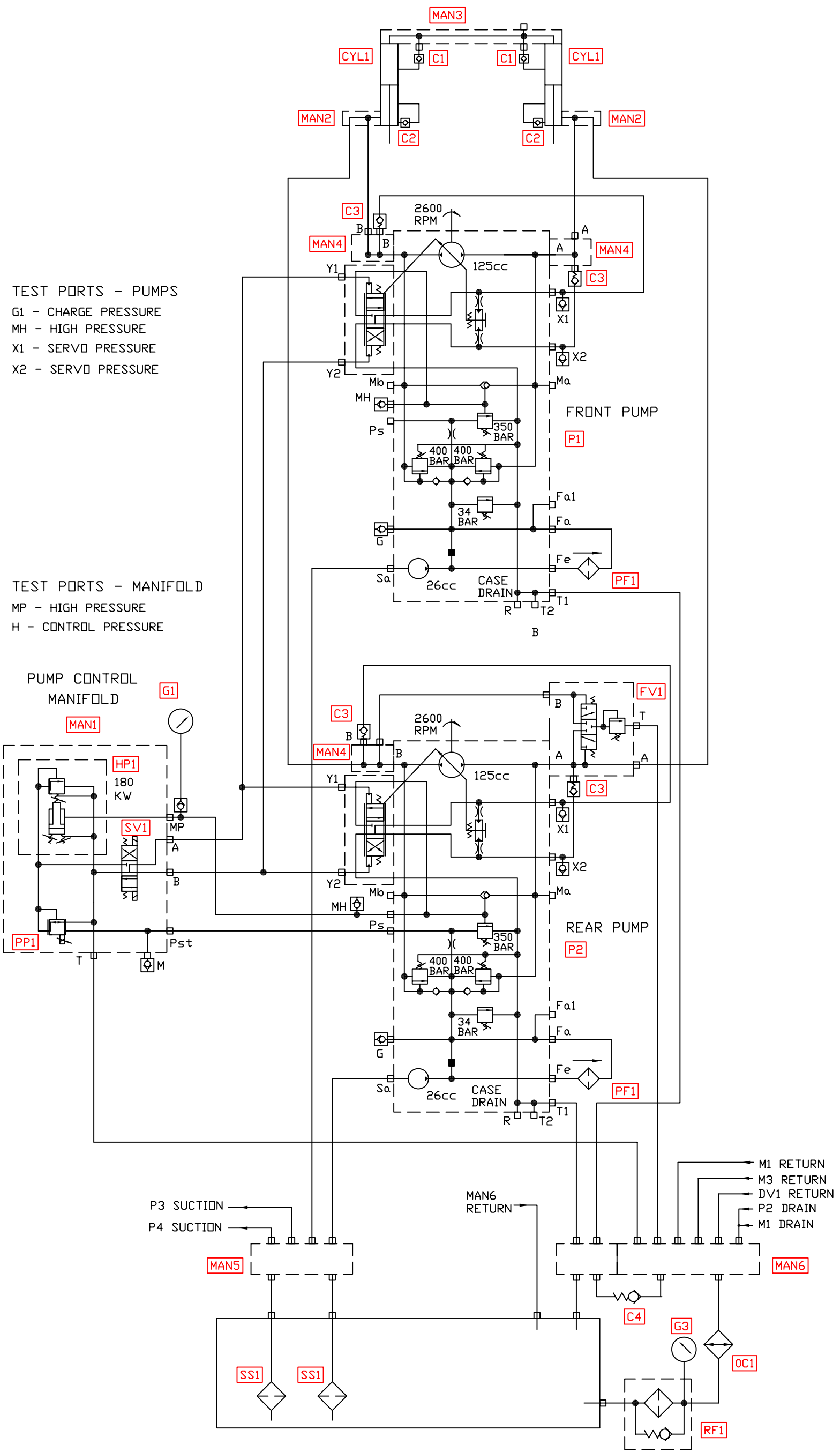

99-178-XT36

REVISION



SWING TUBE CIRCUIT HYDRAULIC COMPONENTS

SCMTC

PAGE 02

CODE NO.	REED'S PARTS NO.	DESCRIPTION	QTY
P3		Pump - S-Tube Circuit - 28 cc	1
CYL2	W-103363	S-Tube Shift Cylinder	1
MAN6	W-104847	Manifold - S-Tube Circuit	1
SV2		Solenoid Valve - S-Tube Circuit	1
SV2-1		Solenoid Valve - Main	1
SV2-2		Solenoid Valve - Pilot	1
		Coil for SV2-2	2
SV3		Solenoid Valve Cartridge	1
		Coil for SV3	1
RV1		Relief Valve Cartridge	1
C4		Check Valve Cartridge	1
BV1		Ball Valve	1
ACC1	W-103616	Accumulator	1
G2	70366	Pressure Gauge - 3000 psi	1
LUB1	W-104402	Lube Block	1

REVISION:



AUXILLIARY CIRCUIT HYDRAULIC COMPONENTS

SCMTC

PAGE 04

CODE NO.	REED'S PARTS NO.	DESCRIPTION	QTY
P4	801022	Tandem Gear Pump - 8/8 cc	1
DV1	W-100124	Directional Valve - Agitator / Water Pump	1
RV1	W-105559	Relief Valve Cartridge	2
SV4	800087	Solenoid Valve - Cooler Bypass	1
		Coil for SV5	1
RV3	78973	Relief Valve - Cooler	1
M1		Motor - Oil Cooler - 7 cc	1
M2	W-101240	Motor - Agitator - 280 cc	2
M3	W-100121	Motor - Water Pump - 5 cc	1
FD1	W-100159	Flow Divider - Agitator	1

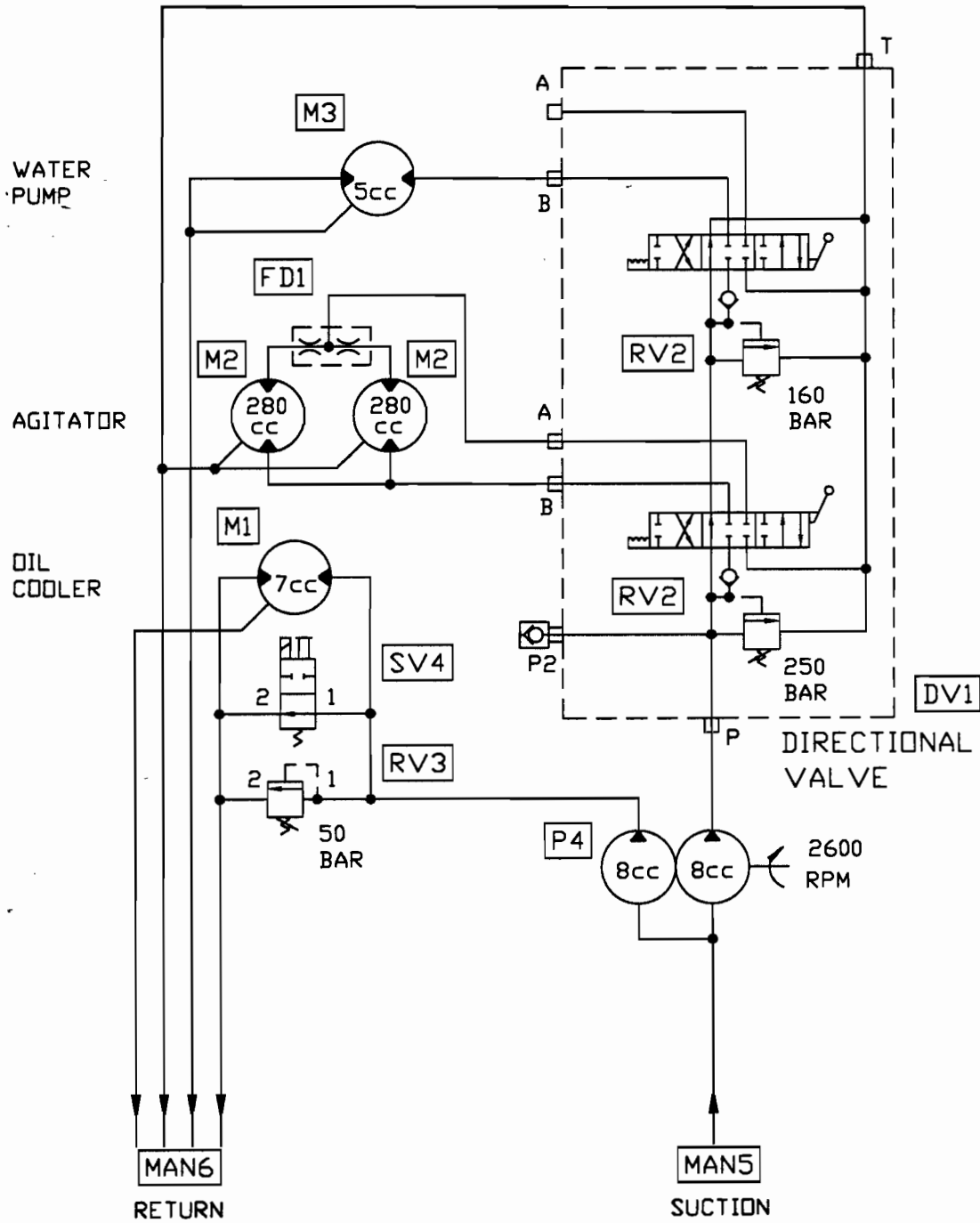

CODE NO.	REED'S PARTS NO.	DESCRIPTION					QTY
		1	2	3	4	5	
1	C-.SE	Tank, Hydraulic Oil					1
2	C-.WR	Valve, Inlet					1
3	C-.FF1	Hose, Flexible					1
4	C-.MP	Pump, Hydraulic					1
5	C-.FF2	Hose, Flexible					1
6	C-DF101	Filter, Hydraulic					1
7	C-DM000	Gauge, Pressure					1
8	C-FF143.100	Hose, Flexible					1
9	C-DD003/DD004	Distributor					1
10	C-FF101.100	Hose, Flexible					1
11	C-FF122.440	Hose, Flexible					8
12	C-FF122.125	Hose, Flexible					8
13	C-WL210	Valve, Flow Limiter					1
14	C-WL213	Valve, Flow Limiter					1
15	C-FF122.070	Hose, Flexible					26
16	C-WC120	Valve, Check					1
17	C-WC132	Valve, Check					2
18	C-.B4	Piston, Hydraulic					1
19	C-WL215	Valve, Flow Limiter					1
20	C-WL125	Valve, Check					5
21	C-.B3	Piston, Hydraulic					1
22	C-WL220	Valve, Flow Limiter					1
23	C-.B2	Piston, Hydraulic					1
24	C-WL218	Valve, Flow Limiter					1
25	C-.B1	Piston, Hydraulic					1
26	C-WA105	Valve, Over Center					1
27	C-.MI	Motor, Hydraulic					1
28	C-FF101.045	Hose, Flexible					2
29	C-WL125	Valve, Flow Limiter					2
30	C-FF134.070	Hose, Flexible					14



BOOM AREA HYDRAULIC SCHEMATIC

SCMTC

PAGE 07

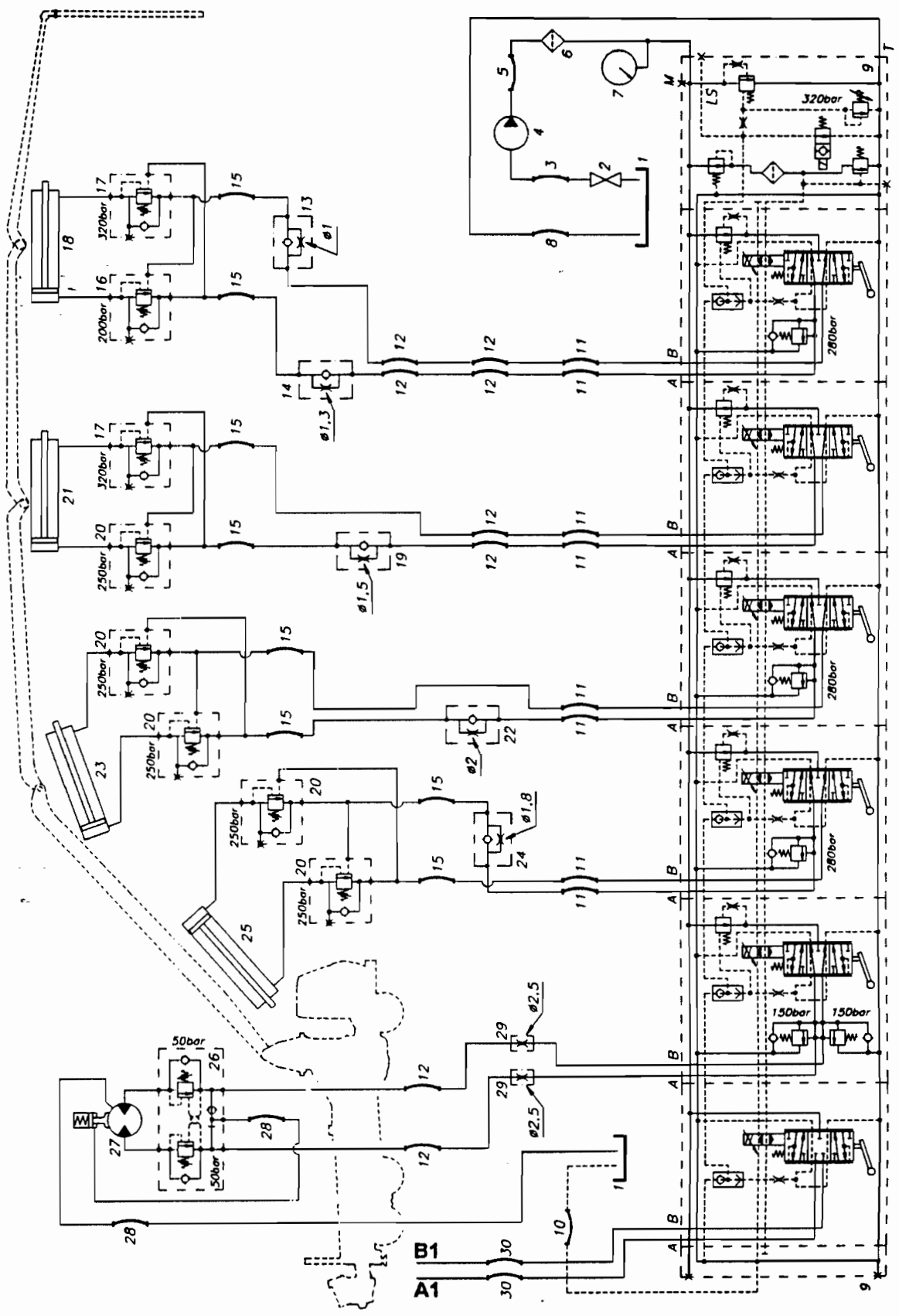

REVISION:



**OUTRIGGER AREA
HYDRAULIC COMPONENTS**

CODE NO.	REED'S PARTS NO.	DESCRIPTION	QTY
		1 2 3 4 5	
31	C-DD011	Distributor, Right Side	1
32	C-DD012	Distributor, Left Side	1
33	C-FF122.060	Hose, Flexible	8
34	C-FF122.310	Hose, Flexible	4
35	C-WD101	Valve, Check	6
36	C-.L5	Piston, Hydraulic	4
37	C-.K4	Piston, Hydraulic	2
38	C-WL110	Valve, 2 Direction Throttle	2
39	C-.M3	Piston, Hydraulic	2

