

**REED TRUCK MOUNTED CONCRETE BOOM PUMP MODEL XT 36 ILLUSTRATED PARTS MANUAL CONTAINS THE FOLLOWING GROUPS AND FIGURES:**

**GROUP 00 HOW TO USE PARTS MANUAL**

- FIGURE 00** TABLE OF CONTENTS
- FIGURE 01** HOW TO USE PARTS MANUAL
- FIGURE 02** HOW TO ORDER PARTS

**GROUP 10 FINAL INSTALLATION**

- FIGURE 00** TABLE OF CONTENTS
- FIGURE 01** FINAL INSTALLATION
- FIGURE 02** DECAL ASSEMBLY

**GROUP 20 HOPPER INSTALLATION**

- FIGURE 00** TABLE OF CONTENTS
- FIGURE 01** HOPPER INSTALLATION
- FIGURE 02** LUBRICATION PUMP ASSEMBLY
- FIGURE 03** CENTRAL LUBRICATION SYSTEM
- FIGURE 04** HOPPER VIBRATION ASSEMBLY
- FIGURE 05** AGITATOR ASSEMBLY
- FIGURE 06** AGITATOR DRIVE MOTOR ASSEMBLY
- FIGURE 07** HOPPER OUTLET ASSEMBLY

**GROUP 30 TANK INSTALLATION**

- FIGURE 00** TABLE OF CONTENTS
- FIGURE 01** TANK INSTALLATION (BEF FEB 2000)
- FIGURE 02** TANK INSTALLATION (AFT MAR 2000)
- FIGURE 03** WATER TANK ASSEMBLY (BEF FEB 2000)
- FIGURE 04** WATER SYSTEM GROUP (AFT MAR 2000)
- FIGURE 05** WASH WATER PUMP ASSEMBLY (BEF FEB 2000)
- FIGURE 06** WASH WATER PUMP ASSEMBLY (AFT MAR 2000)
- FIGURE 07** WATER PUMP MOTOR ASSEMBLY (BEF FEB 2000)
- FIGURE 08** WATER PUMP MOTOR ASSEMBLY (AFT MAR 2000)
- FIGURE 09** HYDRAULIC TANK ASSEMBLY (BEF FEB 2000)
- FIGURE 10** HYDRAULIC TANK ASSEMBLY (AFT MAR 2000)
- FIGURE 11** OIL COOLER MANIFOLD ASSEMBLY

**GROUP 40 POWER TRAIN INSTALLATION**

- FIGURE 00** TABLE OF CONTENTS
- FIGURE 01** POWER TRAIN INSTALLATION (BEF JUL 1999)
- FIGURE 02** POWER TRAIN INSTALLATION (AUG 1999 ~ MAR 2000)
- FIGURE 03** POWER TRAIN INSTALLATION (APR 2000 ~ FEB 2001)
- FIGURE 04** POWER TRAIN INSTALLATION (AFT MAR 2001)
- FIGURE 05** GEAR PUMP ASSEMBLY
- FIGURE 06** PTO GEARBOX ASSEMBLY

**GROUP 50 CONTROLS INSTALLATION**

- FIGURE 00** TABLE OF CONTENTS
- FIGURE 01** CONTROLS INSTALLATION (BEF MAY 2000)
- FIGURE 02** CONTROLS INSTALLATION (AFT JUN 2000)
- FIGURE 03** CAB CONTROLS ASSEMBLY
- FIGURE 04** MAIN CONTROLS ASSEMBLY (BEF MAY 2000)
- FIGURE 05** MAIN CONTROLS ASSEMBLY (AFT JUN 2000)
- FIGURE 06** LH SIDE OUTRIGGER CONTROLS ASSEMBLY
- FIGURE 07** RH SIDE OUTRIGGER CONTROLS ASSEMBLY (BEF MAY 2000)
- FIGURE 08** RH SIDE OUTRIGGER CONTROLS ASSEMBLY (AFT JUN 2000)
- FIGURE 09** STATIONARY BOOM CONTROLS ASSEMBLY (BEF MAY 2000)
- FIGURE 10** STATIONARY BOOM CONTROLS ASSEMBLY (AFT JUN 2000)
- FIGURE 11** CABLED REMOTE CONTROL ASSEMBLY (BEF MAY 2000)
- FIGURE 12** CABLED REMOTE CONTROL ASSEMBLY (AFT JUN 2000)
- FIGURE 13** RADIO REMOTE CONTROL ASSEMBLY (BEF MAY 2000)
- FIGURE 14** RADIO REMOTE CONTROL ASSEMBLY (AFT JUN 2000)
- FIGURE 15** SHUNT ASSEMBLY

**GROUP 60 PUMPING TRAIN INSTALLATION**

- FIGURE 00** TABLE OF CONTENTS
- FIGURE 01** PUMPING TRAIN INSTALLATION
- FIGURE 02** SWING VALVE ASSEMBLY
- FIGURE 03** TILTING DRIVE ASSEMBLY
- FIGURE 04** TILTING CYLINDER ASSEMBLY
- FIGURE 05** CONCRETE CYLINDER ASSEMBLY
- FIGURE 06** WATER BOX ASSEMBLY
- FIGURE 07** HYDRAULIC DRIVE CYLINDER ASSEMBLY
- FIGURE 08** DRIVE CYLINDER SUB-ASSEMBLY

**GROUP 70 FRAME AND SUPPORT INSTALLATION**

<b>FIGURE 00</b>	TABLE OF CONTENTS
<b>FIGURE 01</b>	FRAME AND SUPPORT INSTALLATION
<b>FIGURE 02</b>	TURRET ASSEMBLY
<b>FIGURE 03</b>	MOTOR AND REDUCTION ASSEMBLY
<b>FIGURE 04</b>	ROTATION UNIT ASSEMBLY
<b>FIGURE 05</b>	PEDESTAL ASSEMBLY
<b>FIGURE 06</b>	FRONT OUTRIGGER GROUP ASSEMBLY
<b>FIGURE 07</b>	REAR OUTRIGGER GROUP ASSEMBLY
<b>FIGURE 08</b>	OUTRIGGER EXTEND CYLINDER ASSEMBLY
<b>FIGURE 09</b>	OUTRIGGER JACK CYLINDER ASSEMBLY
<b>FIGURE 10</b>	SWING OUT CYLINDER ASSEMBLY
<b>FIGURE 11</b>	RIGHT HAND SIDE HOSE REEL ASSEMBLY
<b>FIGURE 12</b>	OUTRIGGER HOLDING VALVE ASSEMBLY

**GROUP 80 OPTIONAL INSTALLATION**

<b>FIGURE 00</b>	TABLE OF CONTENTS
<b>FIGURE 01</b>	OPTIONAL INSTALLATION
<b>FIGURE 02</b>	ACCUMULATOR CHARGE KIT
<b>FIGURE 03</b>	OPTIONAL TOO KIT ASSEMBLY

**GROUP 90 BOOM INSTALLATION**

<b>FIGURE 00</b>	TABLE OF CONTENTS
<b>FIGURE 01</b>	BOOM INSTALLATION
<b>FIGURE 02</b>	FIRST BOOM ASSEMBLY
<b>FIGURE 03</b>	SECOND BOOM ASSEMBLY
<b>FIGURE 04</b>	THIRD BOOM ASSEMBLY
<b>FIGURE 05</b>	FOURTH BOOM ASSEMBLY
<b>FIGURE 06</b>	FIRST BOOM CYLINDER ASSEMBLY
<b>FIGURE 07</b>	SECOND BOOM CYLINDER ASSEMBLY
<b>FIGURE 08</b>	THIRD BOOM CYLINDER ASSEMBLY
<b>FIGURE 09</b>	FOURTH BOOM CYLINDER ASSEMBLY
<b>FIGURE 10</b>	CONCRETE PIPELINE ASSEMBLY (DECK AREA)
<b>FIGURE 11</b>	CONCRETE PIPELINE ASSEMBLY (BOOM AREA)

**I. PURPOSE**

This parts manual is prepared, issued and/or revised by **REED** Manufacturing, for the exclusive use of its customers and is intended for use in provisioning, requisitioning, storing and issuing replaceable **REED** truck mounted concrete boom pump model **XT 36**. The contents are proprietary to **REED** and are subject to change without notice. The use of any part of this document by any other person or persons or for any other purpose without the written consent of **REED** is expressly prohibited. In addition, **REED** expressly disclaims any and all responsibility arising in or any way related to such **REED'S** prior written consent thereto.

The parts number content of this document, arrangement and breakdown sequence of items is compatible with Military Standard (**MS**) and Air Transport Association Specification (**ATA**).

**II. GENERAL SYSTEM OF ASSEMBLY ORDER - Detailed Parts List (Refer to Next Page)**

1. This area refers to the corresponding illustration

**MODEL - GROUP - FIGURE - PAGE**

A. **MODEL** shows which is **REED'S** model number.

B. **GROUP** should be divided with:

00	MODEL <b>XT 36</b> ILLUSTRATED PARTS MANUAL
10	FINAL INSTALLATION
20	HOPPER INSTALLATION
30	TANK INSTALLATION
40	POWER TRAIN INSTALLATION
50	CONTROL INSTALLATION
60	PUMPING TRAIN INSTALLATION
70	FRAME AND SUPPORT INSTALLATION
80	OPTIONAL INSTALLATION
90	BOOM INSTALLATION

C. **FIGURE** belong to the group. Please see page of contents and each group.

D. **PAGE** numbers follow to the right of each figure number.

2. The **ITEM NUMBER** corresponds to the item number shown for the part in illustration. Parts with item number preceded by a dash (such as: -1, -5, -12 etc.) are not illustrated.

3. **PARTS NUMBERS** that carry a **REED** part number.



### HYDRAULIC PUMPING ASSEMBLY

**XT 36**  
**PARTS**  
GROUP 60  
FIGURE 06  
PAGE 02

ITEM NO.	REED'S PARTS NO.	DESCRIPTION					QTY
		1	2	3	4	5	
-1	60-06	Assembly, Hydraulic Pumping (See Group 20, Figure 01 for NHA)					Ref
2	78354	• Cup, Piston					2
3	78444	• Coupler					2
4	78352	• Coupling, Dog bone					4
5		• Bolt 1/2 x 4 (attaching parts)					8
6		• Nut, 1/2 (attaching parts)					8
7	78443	• Bone, Dog					2
8		• Bolt 5/8 x 2					6
9	78442	• Coupler					2
10	78438	• Assembly, Hydraulic Cylinder (See Group 60, Figure 07 for DET)					1
11		• Nut (attaching parts)					16
12		• Washer (attaching parts)					16
13	77617	• Bolt (attaching parts)					16
14		• Elbow, 90 FS6802-16-16					4
15	79343	• Assembly, Hose					2
16	78593	• Fitting, MiniCheck (Port)					2
17		• Elbow, 90 FS6802-06-06					4
18		• Fitting, STR FS6400-06-06					4
19	79344	• Assembly, Hose					2
20		• Elbow, 90 FS6801-06-06					4
21		• Valve, Check					4
22		• Elbow, 90 MBMB90-06-06					4
23		• Clamp					3
24	79326	• Tube, Wire					1
25	79345	• Assembly, Tube					2
26	78417	• Cable					2
27	72010	• Loom, 1/2 Flex					A/R
28		• Pin, 1/4 x 20					4
29	79285	• Cover, Proximity Switch					2
30	78416	• Switch, Proximity					2
31	79327	• Plate, End					1
32		• Washer, 1 Lock (attaching parts)					8
33		• Bolt, 1 x 2 Course (attaching parts)					8

DASH (-) ITEM NOT ILLUSTRATED

REVISION:





# MODEL XT 36 TRUCK MOUNTED CONCRETE BOOM PUMP HOW TO USE PARTS MANUAL

**XT 36**  
**PARTS**  
GROUP 00  
FIGURE 01  
PAGE 03



## HYDRAULIC PUMPING ASSEMBLY

**XT 36**  
**PARTS**  
GROUP 60  
FIGURE 06  
PAGE 02

ITEM NO.	REED'S PARTS NO.	DESCRIPTION					QTY
		1	2	3	4	5	
-1	60-06	Assembly, Hydraulic Pumping (See Group 20, Figure 01 for NHA)					Ref
2	78354	• Cup, Piston					2
3	78444	• Coupler					2
4	78352	• Coupling, Dog bone					4
5		• Bolt 1/2 x 4 (attaching parts)					8
6		• Nut, 1/2 (attaching parts)					8
7	78443	• Bone, Dog					2
8		• Bolt 5/8 x 2					6
9	78442	• Coupler					2
10	78438	• Assembly, Hydraulic Cylinder (See Group 60, Figure 07 for DET)					1
11		• Nut (attaching parts)					16
12		• Washer (attaching parts)					16
13	77617	• Bolt (attaching parts)					16
14		• Elbow, 90 FS6802-16-16					4
15	79343	• Assembly, Hose					2
16	78593	• Fitting, MinCheck (Port)					2
17		• Elbow, 90 FS6802-06-06					4
18		• Fitting, STR FS6400-06-06					4
19	79344	• Assembly, Hose					2
20		• Elbow, 90 FS6801-06-06					4
21		• Valve, Check					4
22		• Elbow, 90 MBMB90-06-06					4
23		• Clamp					3
24	79326	• Tube, Wire					1
25	79345	• Assembly, Tube					2
26	78417	• Cable					2
27	72010	• Loom, 1/2 Flex					A/R
28		• Pin, 1/4 x 20					4
29	79285	• Cover, Proximity Switch					2
30	78416	• Switch, Proximity					2
31	79327	• Plate, End					1
32		• Washer, 1 Lock (attaching parts)					8
33		• Bolt, 1 x 2 Course (attaching parts)					8

DASH (-) ITEM NOT ILLUSTRATED

REVISION:



#### 4. DESCRIPTION

- A. The **INDENTURE SYSTEM** used in the parts list shows the relationship of one part to another. For a given item, the number of indentures depicts the relationship of the item to the components of the item as follows:

**1 2 3 4 5**

**Assembly (or Installation)**

- **Detail part of assembly**
- **Sub-assembly**
- **Attaching parts for sub-assembly**
- ● **Detail part of sub-assembly**
- ● **Sub-sub-assembly**
- ● **Attaching parts for sub-sub-assembly**
- ● ● **Detail part of sub-sub-assembly**
- ● ● **Sub-sub-sub-assembly**
- ● ● **Attaching parts of sub-sub-sub-assembly**
- ● ● ● **Detail part of sub-sub-sub-assembly**

- B. "See Group 20, Figure 01 For **NHA**"  
Identifies the illustrated parts chapter location; indicates where the Next Higher Assembly (**NHA**) of the item shown.
- C. "See Group 60, Figure 07 For **DET**"  
Identifies the illustrated parts chapter location; indicates where the item and its Detailed Breakdown (**DET**) is shown.
- D. "See Group 30, Figure 05 for **REF**" or "See Vendor Chapter For **REF**"  
Identifies the illustrated parts chapter where the part is, and if listed and illustrated in Vendor Chapter. It is used as a cross-reference (**REF**).

#### 5. QUANTITY

- A. Reference (**REF**) indicates the items that is listed previously in the Next Higher Assembly (**NHA**) and then again in this figure.
- B. As Required (**A/R**) indicates the parts that is used in a quantity as required.
- C. A number entry indicates the quantity of the part used in its next higher application.
6. Functionally related assemblies are illustrated in phantom ( \_\_\_\_\_ ) but not listed on the detail parts list page.

1. Always give serial number and model of **REED** truck mounted concrete boom pump model: **XT 36**. (Refer to each unit name plate shown below). NOTE: This manual is being released to cover unit starting with serial number **98-178-XT 36** to current production. Some components used on earlier units differ from current productions. Where this occurs, the part is identified by a serial number.

<b>REED</b>		PHONE (909) 364-2100		CE
13822 OAKS AVENUE CHINO, CA 90710 USA		FAX (909) 364-2140		
MODEL	<input type="text"/>	SERIAL NO.	<input type="text"/>	
HYD. PRESSURE	<input type="text"/>	PSI	<input type="text"/>	BAR
ELECTRIC MOTOR/ ENGINE SPEED	<input type="text"/>	RPM	<input type="text"/>	VOLTS
VEHICLE WEIGHT (APPROX.)	<input type="text"/>	LBS	<input type="text"/>	KG
<small>75009A</small>				

2. Always specify part number and complete name of parts ordered.
  - A. Turn to table of content in the desired Installation.  
Refer to main group in which part should be listed.

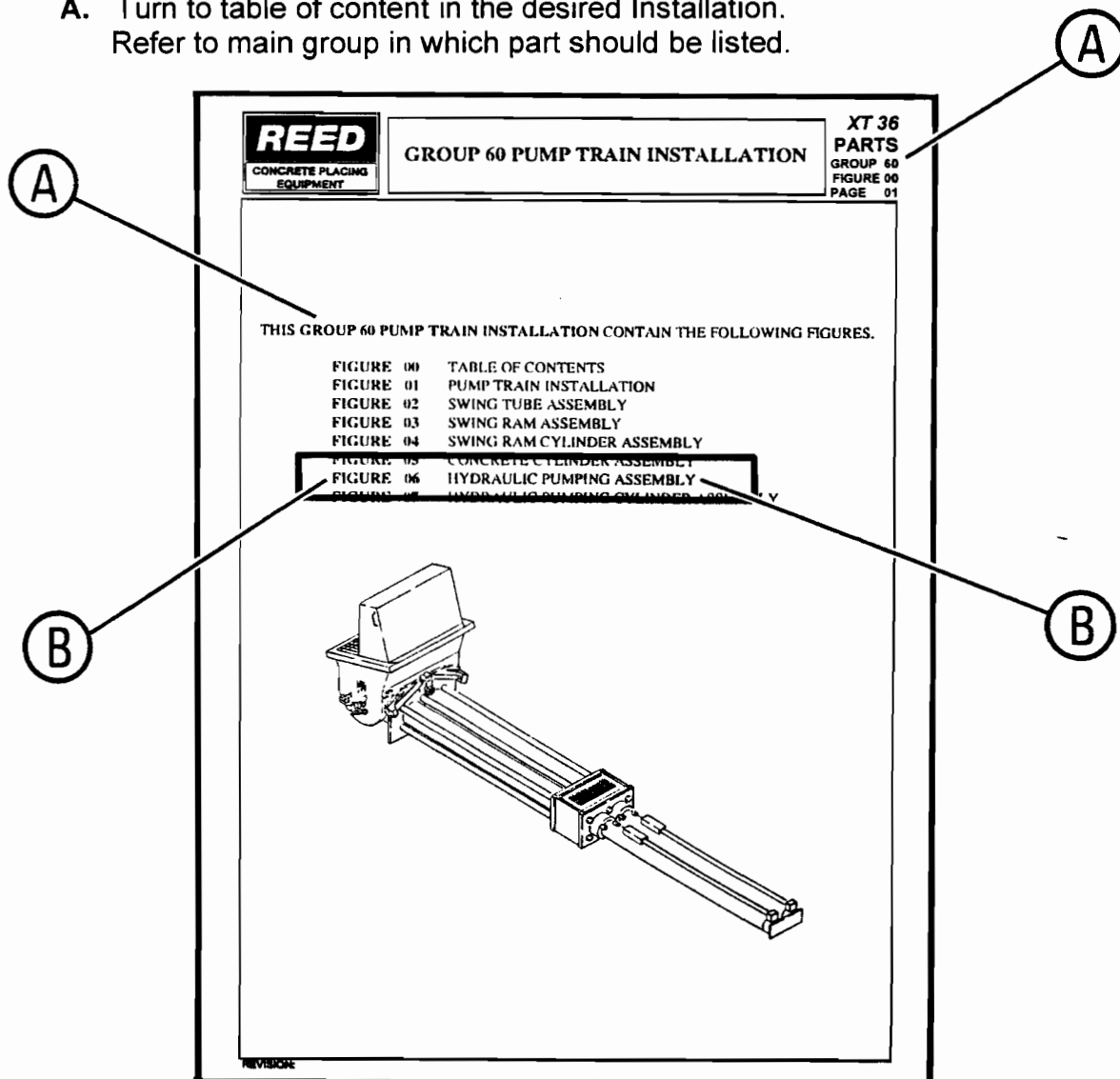



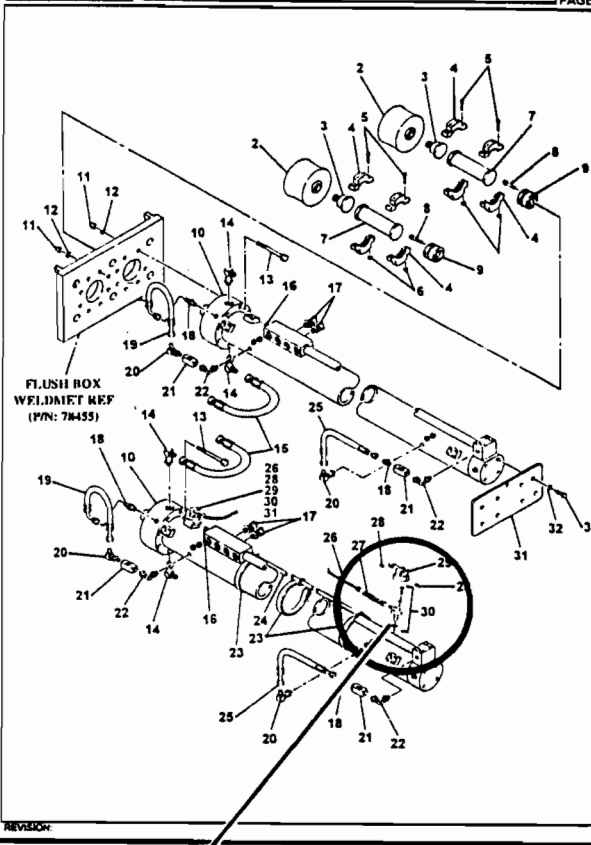

REVISION:

ITEM NO.	REED'S PARTS NO.	DESCRIPTION	QTY
-1	60-06	Assembly, Hydraulic Pumping (See Group 20, Figure 1 for NHA)	Ref
2	78154	* Cup, Piston	2
3	78444	* Coupler	2
4	78152	* Coupling, Dowel	4
5		* Bolt, 1/2 x 4 (attaching parts)	8
6		* Nut, 1/2 (attaching parts)	8
7	78441	* Hose, Dowel	2
8		* Bolt, 5/8 x 2	6
9	78442	* Coupler	2
10	78438	* Assembly, Hydraulic Cylinder (See Group 60, Figure 07 for DET)	1
11		* Nut (attaching parts)	16
12		* Washer (attaching parts)	16
13	77617	* Bolt (attaching parts)	16
14		* Elbow, 90 FSA012-16-16	4
15	79343	* Assembly, Hose	2
16	78591	* Fitting, Manifold (Part)	2
17		* Elbow, 90 FSA012-48-48	4
18		* Fitting, STR FSA010-48-48	4
19	79344	* Assembly, Hose	2
20		* Fitting, 90 FSA011-48-48	4
21		* Fitting, Check	4
22		* Elbow, 90 MHM090-16-16	4
23		* Clamp	3
24	79126	* Tube, Wire	1
25	79345	* Assembly, Tube	2
26	78417	* Cable	2
27	72010	* Lawn, 1/2 Flex	A/R
28		* Pin, 1/4 x 20	4
29	79283	* Cover, Proximity Switch	2
30	78446	* Switch, Proximity	2
31	78435	* Flush Box Weldment	1
32		* Washer, 1 Lock (attaching parts)	8
33		* Bolt, 1 x 2 Course (attaching parts)	8

DASH (-) ITEM NOT ILLUSTRATED

REVISION:

- B. Find title of figure in which the part should be shown. Note figure number.
- C. Turn to corresponding page, find the group and figure.
- D. Check your required part and its attaching parts and match with illustration page.
- E. Refer to corresponding item number in the part list page. Part numbers are located in the part number column.
- F. When ordering variable or optional miscellaneous parts which are not found this in parts chapter, follow the above outlined procedure of how to order parts.
  - 1). When applicable, give model and serial number of the component for which parts are desired.
  - 2). In a specific, difficult to describe situation, a marked-up photograph or detailed sketch would be helpful.

3. Do not designate quantity by "set". State specifically how many parts are wanted.
4. Always give complete address and full shipping instructions. Specify shipping instructions, truck freight, air freight. United Parcel Service (UPS), or FEDEX and DHL are available in designated areas.

**5. TO ORDER****A. BY MAIL**

Attention: Parts Department  
**REED LLC**  
13822 Oaks Avenue  
Chino, CA. 91710

**B. BY FAX**

(909) 287 - 2141

**C. BY PHONE**

(909) 287 - 2100

6. Parts return without authorization will not be accepted. If it is necessary to return parts for any reason, written authorization may be obtained from **REED** Parts Department, Chino, CA. 91710-7008. A Parts Return Authorization form is provided when **REED** deems its necessary to have the part returned for evaluation. The form is issued by the Warranty of Parts Department of **REED**.
  - A. The form will be filled by **REED** unless requesting necessary information and you will receive a copy as well as shipping tag.
  - B. Attach shipping tag to part insert return original invoice.
  - C. Ship part to **REED PREPAID**.
  - D. Part must be returned to **REED** within 30 days from date of authorization.

# REED

## MODEL XT 36 TRUCK MOUNTED CONCRETE BOOM PUMP GROUP 10 FINAL INSTALLATION

XT 36  
PARTS  
GROUP 10  
FIGURE 00  
PAGE 01

**REED** TRUCK MOUNTED CONCRETE BOOM PUMP MODEL **XT 36** ILLUSTRATED PARTS MANUAL GROUP 10 FINAL INSTALLATION CONTAINS THE FOLLOWING FIGURES:

- FIGURE 00 TABLE OF CONTENTS
- FIGURE 01 FINAL INSTALLATION
- FIGURE 02 DECAL ASSEMBLY

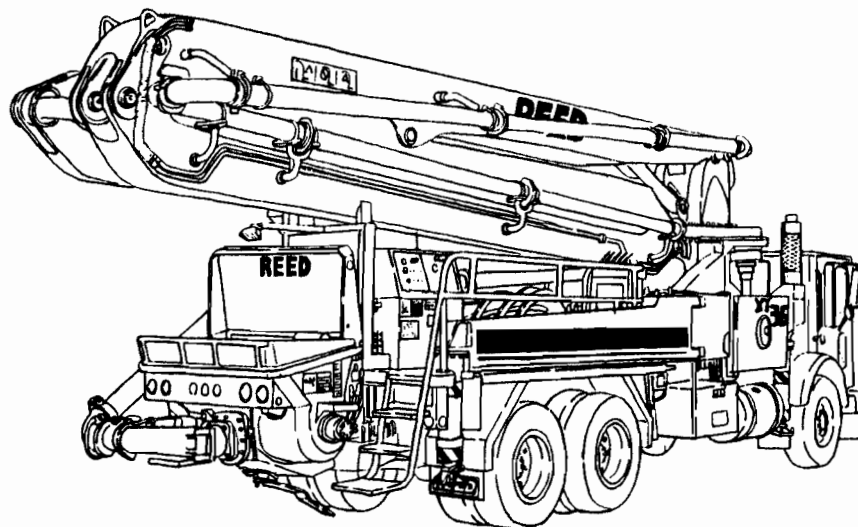

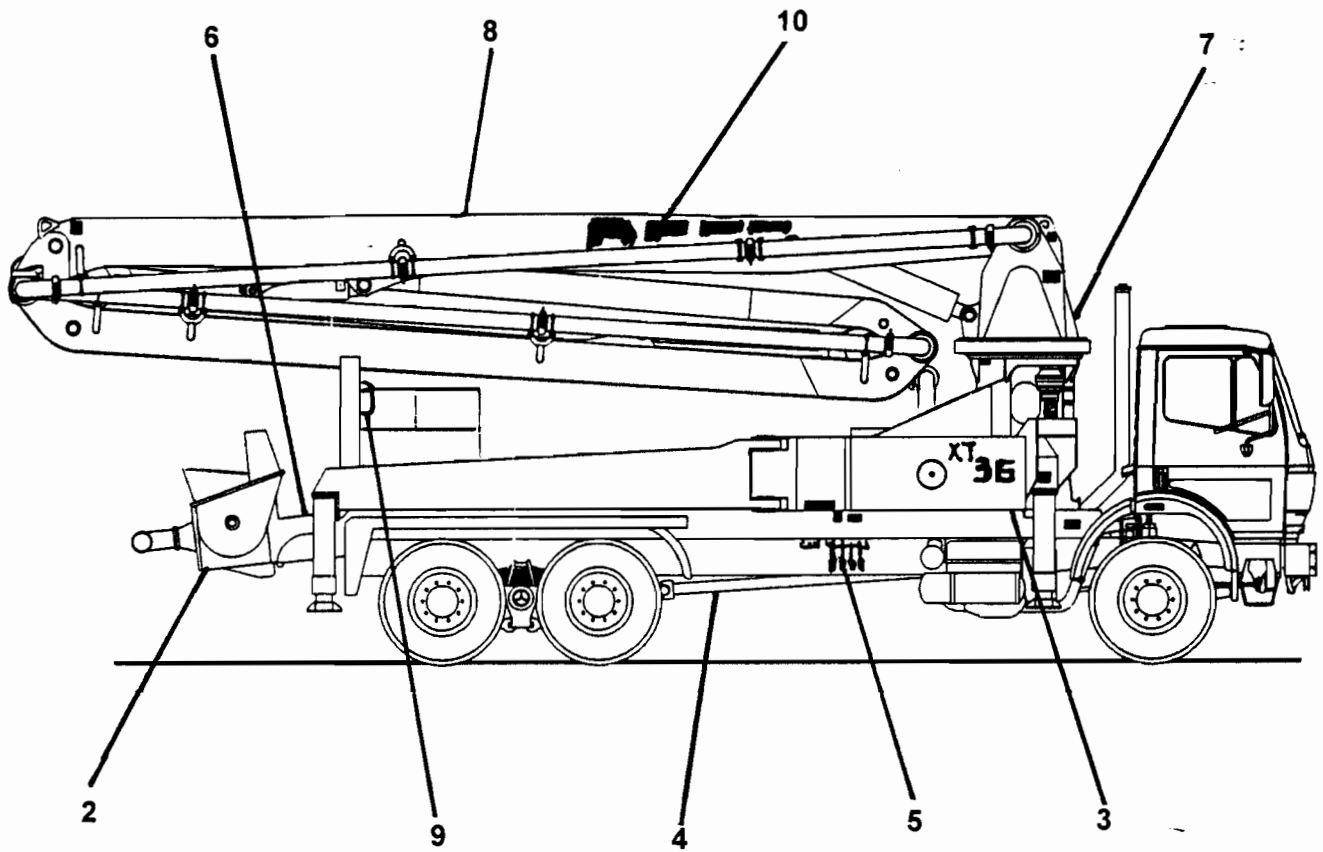

ITEM NO.	REED'S PARTS NO.	DESCRIPTION					QTY
		1	2	3	4	5	
-1	800518	Installation, <b>XT 36</b> Final					Ref
2	20-01	• Installation, Hopper (See Group 20, Figure 01 for DET)					1
3	30-01	• Installation, Tank (Bef Feb 2000) (See Group 30, Figure 01 for DET)					1
	30-02	• Installation, Tank (Bef Mar 2000) (See Group 30, Figure 02 for DET)					1
4	40-01	• Installation, Power Train (Bef Jul 1999) (See Group 40, Figure 01 for DET)					1
	40-02	• Installation, Power Train (Aug 1999 ~ Mar 2000) (See Group 40, Figure 01 for DET)					1
	40-03	• Installation, Power Train (Apr 200 ~ Feb 2001) (See Group 40, Figure 01 for DET)					1
	40-04	• Installation, Power Train (Aft Mar 2001) (See Group 40, Figure 01 for DET)					1
5	50-01	• Installation, Control (Bef May 2000) (See Group 50, Figure 01 for DET)					1
	50-02	• Installation, Control (Aft Jun 2000) (See Group 50, Figure 01 for DET)					1
6	60-01	• Installation, Pumping Train (See Group 60, Figure 01 for DET)					1
7	70-01	• Installation, Frame and Support (See Group 70, Figure 01 for DET)					1
8	80-01	• Installation, Optional (See Group 80, Figure 01 for DET)					1
9	90-01	• Installation, Boom (See Group 90, Figure 01 for DET)					1
10	10-02	• Assembly, Decal (See Group 10, Figure 02 for DET)					1

DASH (-) ITEM NOT ILLUSTRATED



# DECAL ASSEMBLY

XT 36  
PARTS  
GROUP 10  
FIGURE 02  
PAGE 01

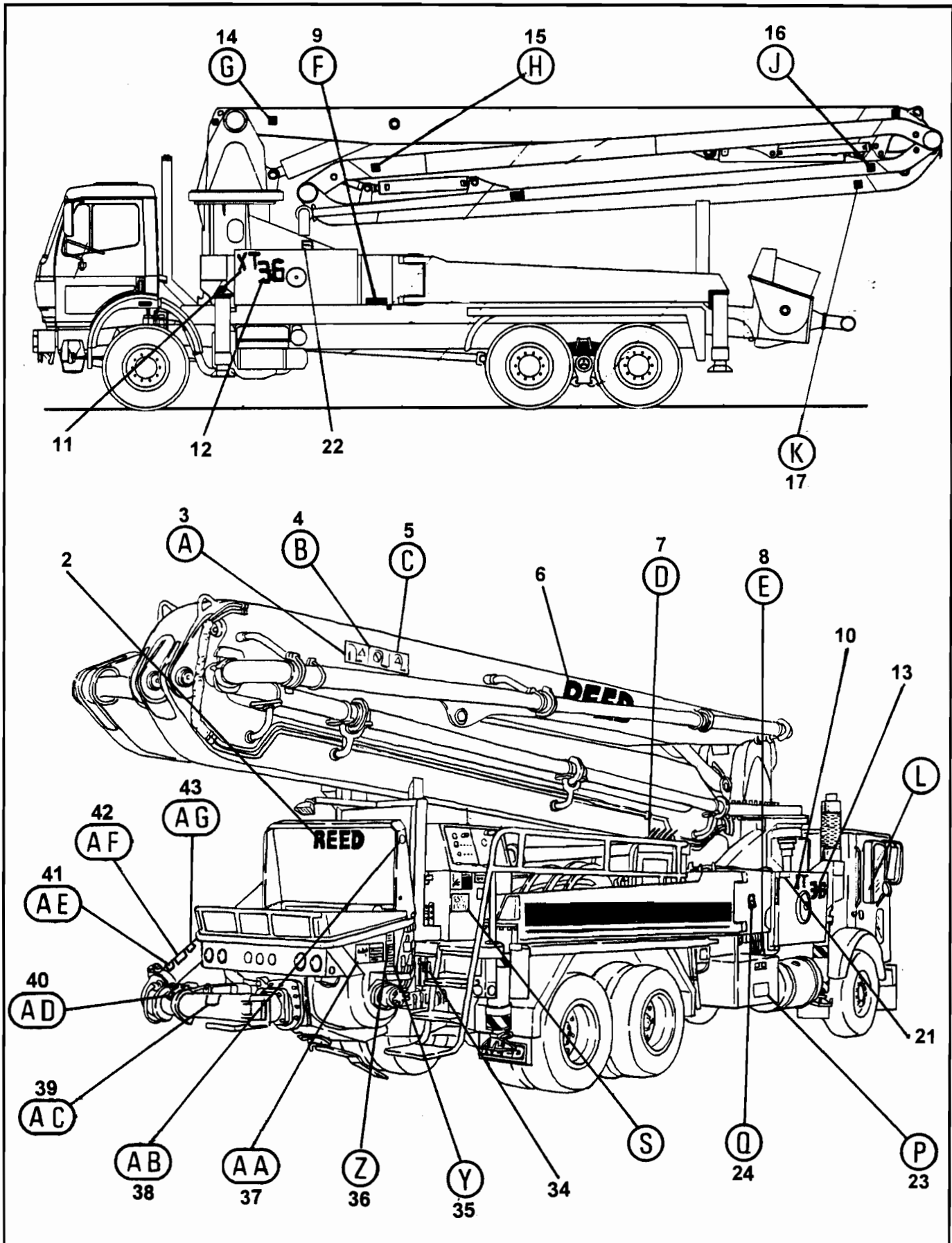

REVISION:

ITEM NO.	REED'S PARTS NO.	DESCRIPTION					QTY
		1	2	3	4	5	
-1	10-02	Assembly, Decal (See Group 10, Figure 01 for NHA)					Ref
2	800442	• Decal, <b>REED</b> , 6 Inch Black					1
3	C-4V107	• Plate, Danger Of Falling Object					1
4	C-4V106	• Plate, Never Use As Crane					1
5	C-4V105	• Plate, Death Hazard					1
6	801069	• Decal, <b>REED</b> , 12 Inch White					2
7	802272	• Nameplate, Boom Valve					1
8	802271	• Nameplate, <b>XT 36</b> Right Side Outrigger					1
9	802270	• Nameplate, <b>XT 36</b> Left Side Outrigger					1
10	801066	• Decal, <b>XT</b> , 4 Inch White					1
11	801067	• Decal, <b>XT</b> , 5 Inch White					1
12	801071	• Decal, <b>36</b> , 8 Inch White					1
13	801072	• Decal, <b>36</b> , 7 Inch White					1
14	C-4V113	• Decal, <b>A</b> Letter Adhesive					1
15	C-4V115	• Decal, <b>C</b> Letter Adhesive					1
16	C-4V116	• Decal, <b>D</b> Letter Adhesive					1
17	C-4V114	• Decal, <b>B</b> Letter Adhesive					1
-18	800766	• Kit, <b>XT 36</b> Decal					1
19	800051	•• Nameplate, PTO					1
20	800059	•• Plate, PTO Operation					1
21	800034	•• Decal, Oil Level					2
22	800033	•• Decal, Water					1
23	800915	•• Decal, Danger, Stay Clear					1
24	800919	•• Decal, Warning, Stand Clear of Outriggers when activating					4
-25	800920	•• Decal, Warning, Clear Area Before Activating Outriggers					2
26	800439	•• Decal, Control Box Panel					1
27	801113	•• Decal, Gauge					1
28		•• Decal, A B					1
29	800926	•• Decal, Warning, Do Not Operate This Machine without					1
30	800929	•• Decal, Warning					1
31	800925	•• Decal, Warning, Do Not Operate This Machine without					1
32	800930	•• Decal, <b>ACPA</b> Hand Signals					1
33	800913	•• Decal, Danger, Electrocutation Hazard					1
34	800875	•• Nameplate, Agitator / Water					1
35	800918	•• Decal, Warning, Do Not Stand on Hopper Grate					2
36	800917	•• Decal, Warning, Keep Hand Out of Hopper and Valve					2
37	800924	•• Decal, Warning, This Machine is Remote Controlled and					1
38	800931	•• Decal, <b>ACPA</b> Member					1
39	800922	•• Decal, Warning, Before Opening a Blocked Pipeline,					1
40	800923	•• Decal, Warning, Use Retaining Pins in all Delivery					1
41	800928	•• Decal, Warning, Total Weight of all Hanging Hoses,					1
42	800927	•• Decal, Warning, Do Not Use the Boom as a Crane					1
43	800921	•• Decal, Warning, Do Not Operate at Pressures Exceeding					1
-44	800914	•• Decal, Danger, Electrocutation Hazard					1
-45	800916	•• Decal, Warning, Keep Hand Out of Water Box					1
46	75009	•• Nameplate, <b>REED</b> , Serial No.					1

DASH (-) ITEM NOT ILLUSTRATED

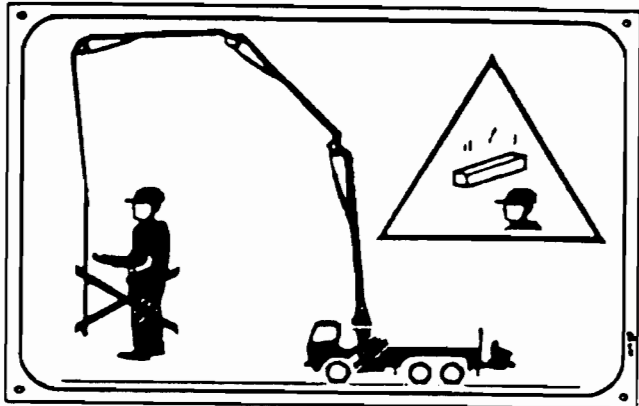

(A)

3

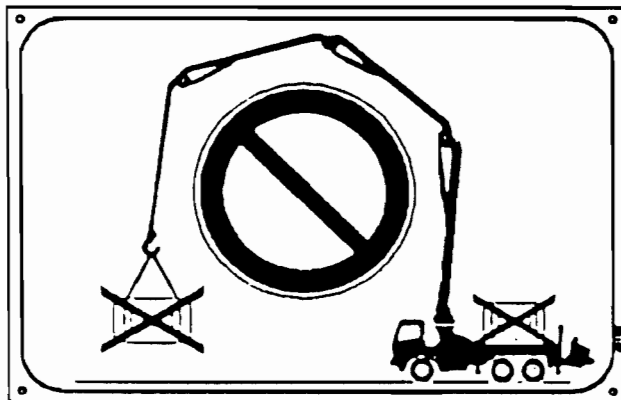

(B)

4

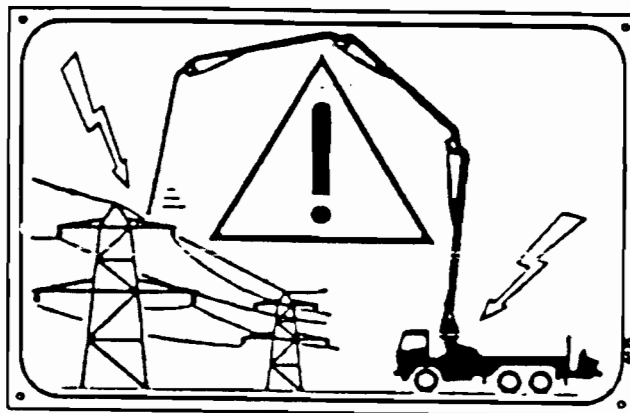

(C)

5

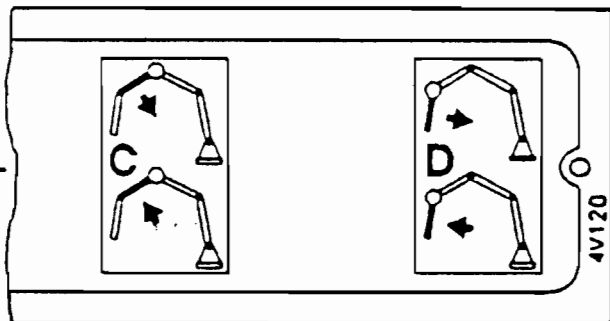

(D)

7

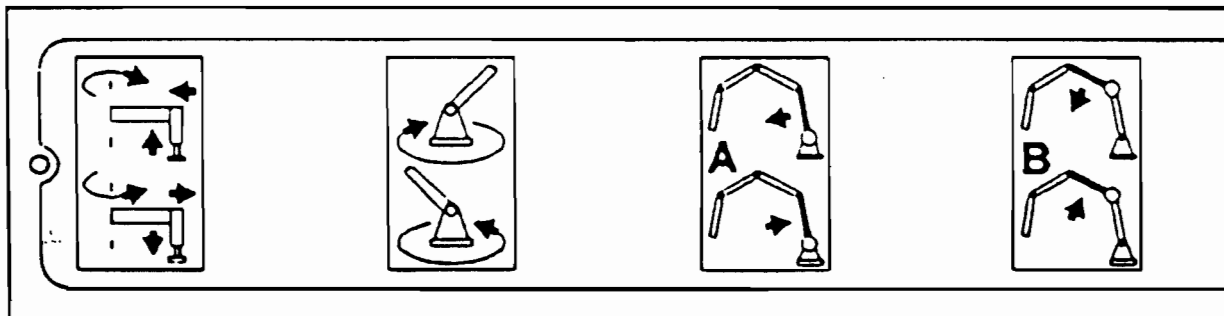



**REED**

DECAL ASSEMBLY

XT 36  
PARTS  
GROUP 10  
FIGURE 02  
PAGE 04

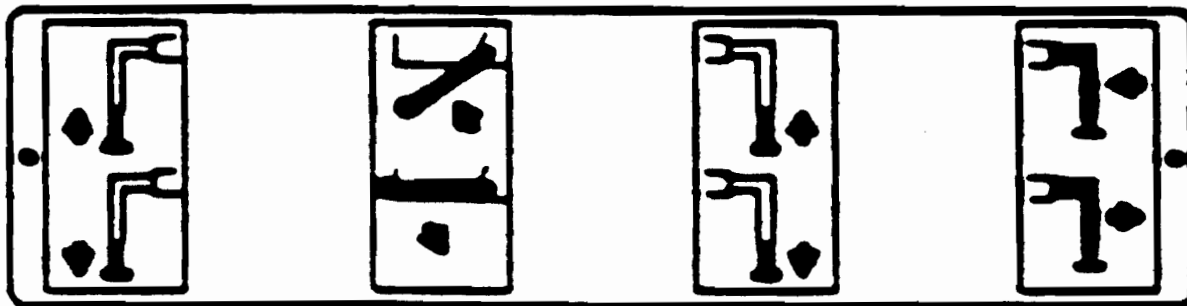

(E)

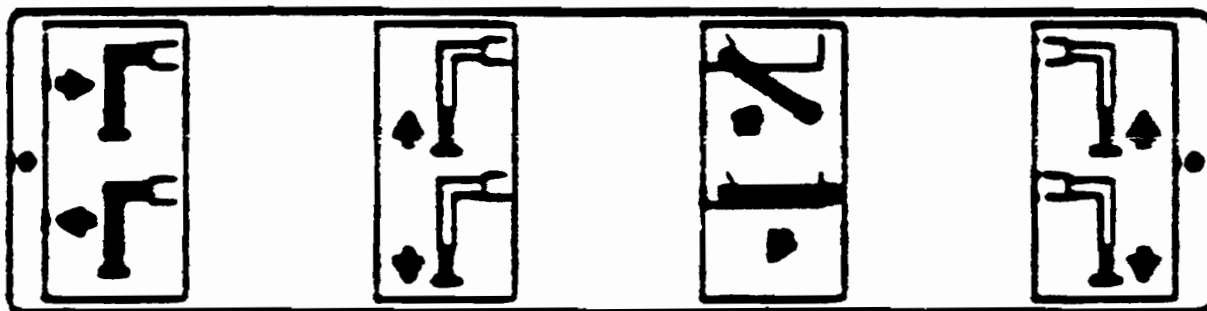

(F)

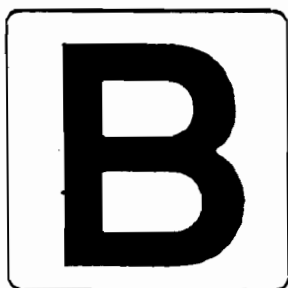

17

(K)



14

(G)

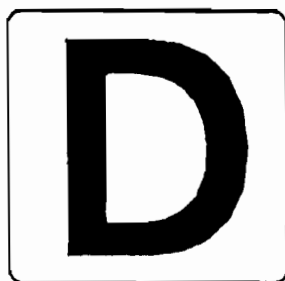

16

(J)

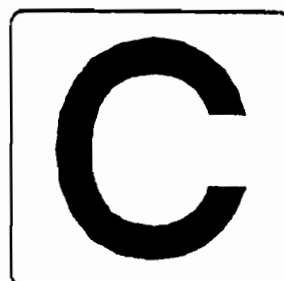

(H)

15

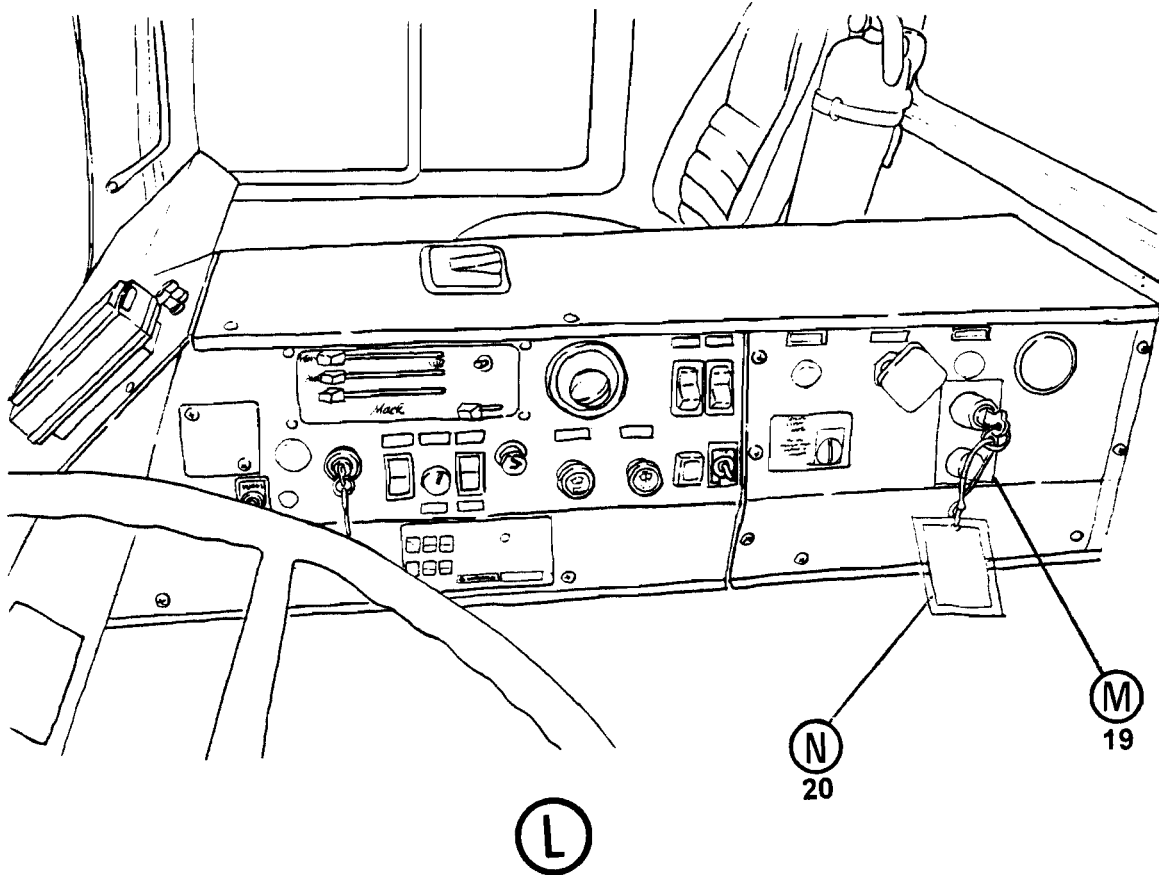

### TO OPERATE PUMP AND BOOM

1. POSITION TRUCK AND SET PARKING BRAKE.
2. DEPRESS CLUTCH AND SHIFT TO 7TH GEAR HIGH.
3. TURN PTO ON.
4. RELEASE CLUTCH TO ENGAGE PUMPS.
5. SET THROTTLE AT 1600 RPM MAXIMUM.

### TO RETURN TO DRIVING MODE

1. RETURN THROTTLE TO IDLE.
2. DEPRESS CLUTCH AND TURN PTO OFF.
3. SHIFT TO NEUTRAL AND RELEASE CLUTCH.

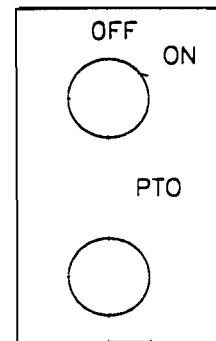

20

19

(N)

(M)

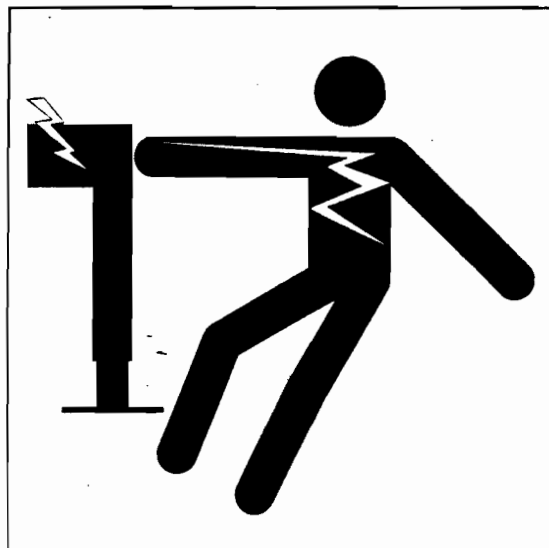

# ⚠ DANGER

Stay clear.  
Contact will result in  
death or serious injury  
if the unit becomes  
electrically charged.

800915

23

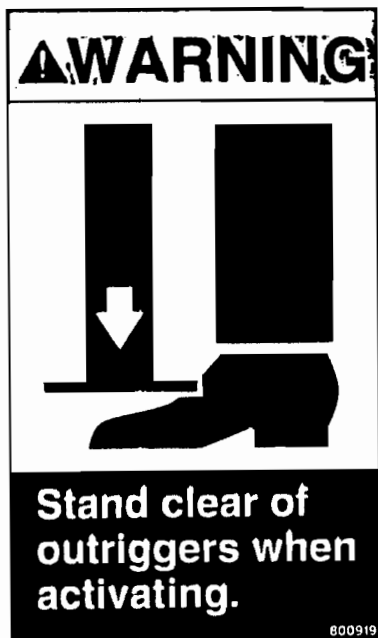

25

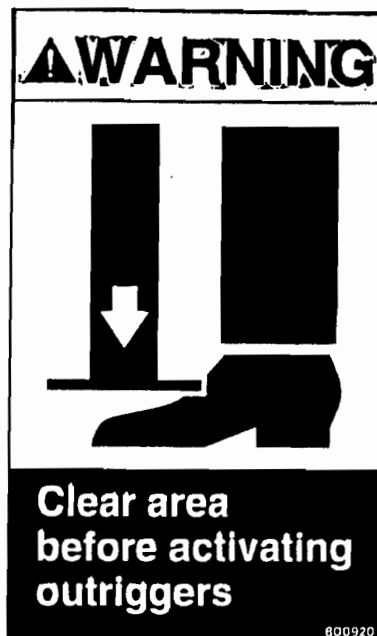



24

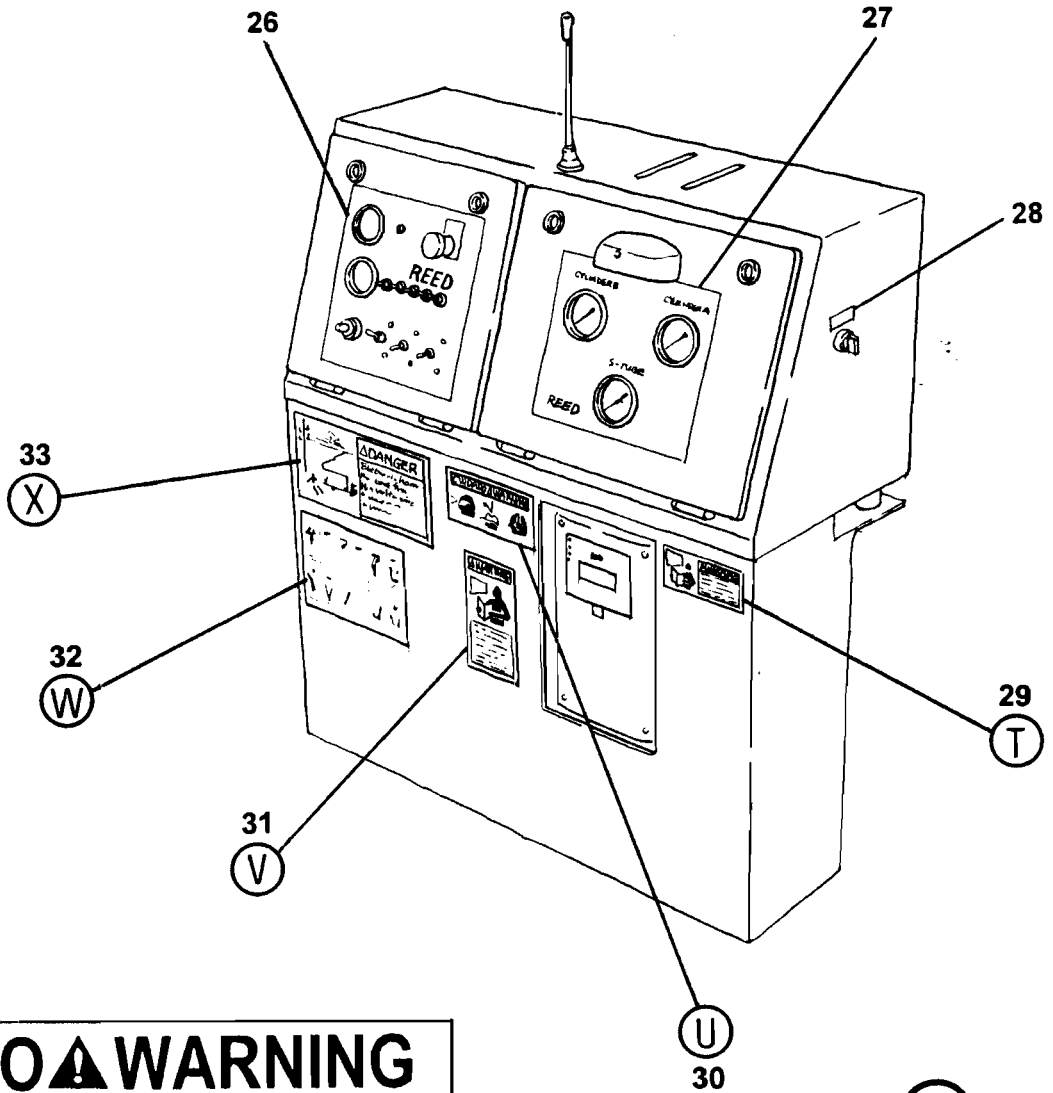

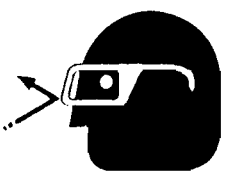
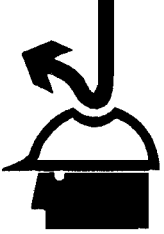

**CUIDADO ⚠ WARNING**

		
---	---	---

800929

U

30

29

T

**⚠ WARNING**

Do not operate this machine without training. Understand the warnings in safety manuals and on decals.



800928

### ▲ WARNING



31

**Do not operate  
this machine  
without training.  
Understand the  
warnings in  
safety manuals  
and on decals.**



800925



32



1. BOOM UP



2. BOOM DOWN



3. BOOM LEFT



4. BOOM RIGHT



5. OPEN OR  
EXTEND BOOM



6. CLOSE OR  
RETRACT BOOM



7. STOP BOOM



8. START PUMP  
SPEED UP



9. SLOW PUMP  
DOWN



10. STOP PUMP



11. LITTLE BIT



12. ADD WATER  
4-GALLONS



13. ALL DONE  
CLEAN UP

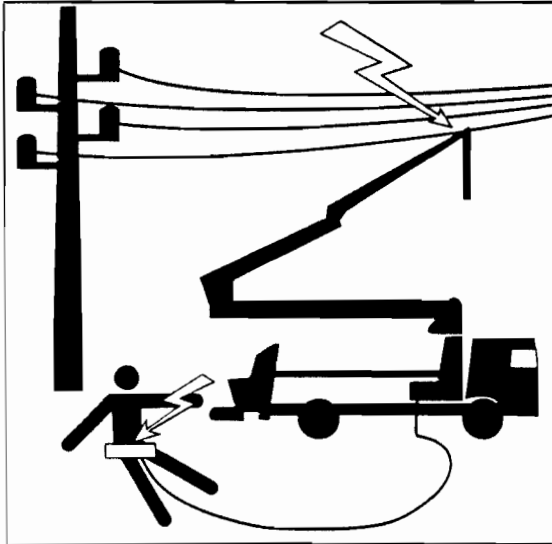

# ⚠ DANGER

Electrocution hazard.  
Stay back from  
high voltage wires  
at least 17 feet  
(5 meters).

800913



33

## ⚠ WARNING

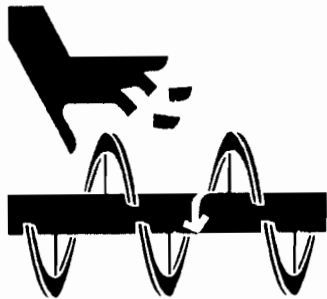

Keep hands out  
of hopper and  
valve assembly.  
See operation  
manual if access  
is required.

800917



36

## ⚠ WARNING



Do not stand on  
hopper grates.

800918



35



### **! WARNING**

**This machine is remote controlled and may start at any time. Stop engine before servicing unit.**

800924

AA

37



### **! WARNING**

**Use retaining pins in all delivery system snap clamps.**

800923

AD

40



38

AB

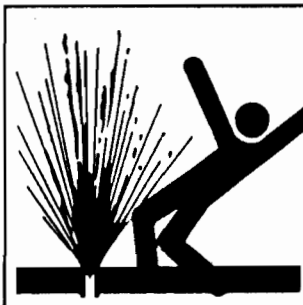

### **! WARNING**

**Before opening a blocked pipeline, relieve pressure by reversing pump. See manual.**

800922

39

AC

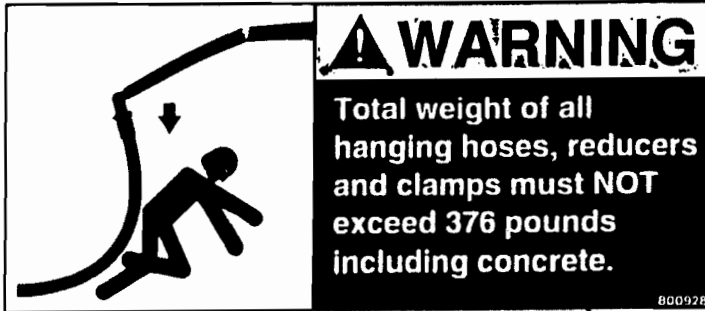

AE

41



AF

42



AG

43



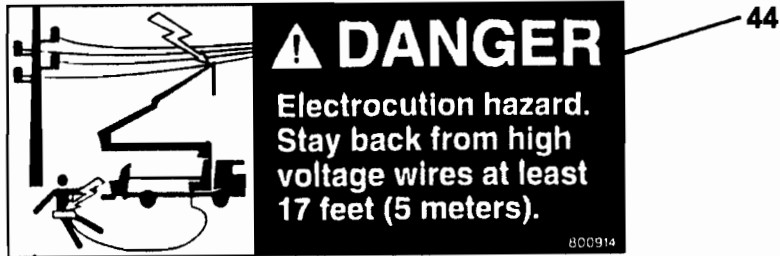

**⚠ DANGER**  
Electrocutation hazard.  
Stay back from high  
voltage wires at least  
17 feet (5 meters).

800914

AH



**⚠ WARNING**  
Keep hands out of  
waterbox.  
Stop engine/motor if  
access is required.  
Keep guards in place.

800916

AJ

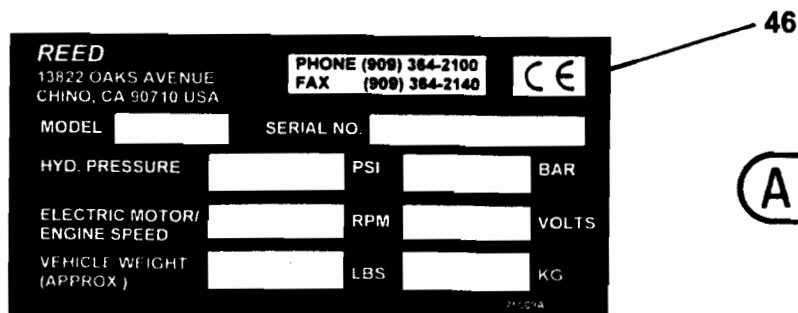

**REED**  
13822 OAKS AVENUE  
CHINO, CA 90710 USA

PHONE (909) 384-2100  
FAX (909) 384-2140

CE

MODEL  SERIAL NO.

HYD. PRESSURE  PSI  BAR

ELECTRIC MOTOR/  
ENGINE SPEED  RPM  VOLTS

VEHICLE WEIGHT  
(APPROX)  LBS  KG

715014

AK

ITEM NO.	REED'S PARTS NO.	DESCRIPTION	QTY
-1	10-02	Assembly, Decal (See Group 10, Figure 01 for NHA)	Ref
2	800442	• Decal, <b>REED</b> , 6 Inch Black	1
3	C-4V107	• Plate, Danger Of Falling Object	1
4	C-4V106	• Plate, Never Use As Crane	1
5	C-4V105	• Plate, Death Hazard	1
6	801069	• Decal, <b>REED</b> , 12 Inch White	2
7	802272	• Nameplate, Boom Valve	1
8	802271	• Nameplate, <b>XT 36</b> Right Side Outrigger	1
9	802270	• Nameplate, <b>XT 36</b> Left Side Outrigger	1
10	801066	• Decal, <b>XT</b> , 4 Inch White	1
11	801067	• Decal, <b>XT</b> , 5 Inch White	1
12	801071	• Decal, <b>36</b> , 8 Inch White	1
13	801072	• Decal, <b>36</b> , 7 Inch White	1
14	C-4V113	• Decal, <b>A</b> Letter Adhesive	1
15	C-4V115	• Decal, <b>C</b> Letter Adhesive	1
16	C-4V116	• Decal, <b>D</b> Letter Adhesive	1
17	C-4V114	• Decal, <b>B</b> Letter Adhesive	1
-18	800766	• Kit, <b>XT 36</b> Decal	1
19	800051	•• Nameplate, PTO	1
20	800059	•• Plate, PTO Operation	1
21	800034	•• Decal, Oil Level	2
22	800033	•• Decal, Water	1
23	800915	•• Decal, Danger, Stay Clear	1
24	800919	•• Decal, Warning, Stand Clear of Outriggers when activating	4
-25	800920	•• Decal, Warning, Clear Area Before Activating Outriggers	2
26	800439	•• Decal, Control Box Panel	1
27	801113	•• Decal, Gauge	1
28		•• Decal, A B	1
29	800926	•• Decal, Warning, Do Not Operate This Machine without	1
30	800929	•• Decal, Warning	1
-31	800925	•• Decal, Warning, Do Not Operate This Machine without	1
32	800930	•• Decal, <b>ACPA</b> Hand Signals	1
33	800913	•• Decal, Danger, Electrocution Hazard	1
34	800875	•• Nameplate, Agitator / Water	1
35	800918	•• Decal, Warning, Do Not Stand on Hopper Grate	2
36	800917	•• Decal, Warning, Keep Hand Out of Hopper and Valve	2
37	800924	•• Decal, Warning, This Machine is Remote Controlled and	1
38	800931	•• Decal, <b>ACPA</b> Member	1
39	800922	•• Decal, Warning, Before Opening a Blocked Pipeline,	1
40	800923	•• Decal, Warning, Use Retaining Pins in all Delivery	1
41	800928	•• Decal, Warning, Total Weight of all Hanging Hoses,	1
42	800927	•• Decal, Warning, Do Not Use the Boom as a Crane	1
43	800921	•• Decal, Warning, Do Not Operate at Pressures Exceeding	1
-44	800914	•• Decal, Danger, Electrocution Hazard	1
-45	800916	•• Decal, Warning, Keep Hand Out of Water Box	1
46	75009	•• Nameplate, <b>REED</b> , Serial No.	1

DASH (-) ITEM NOT ILLUSTRATED

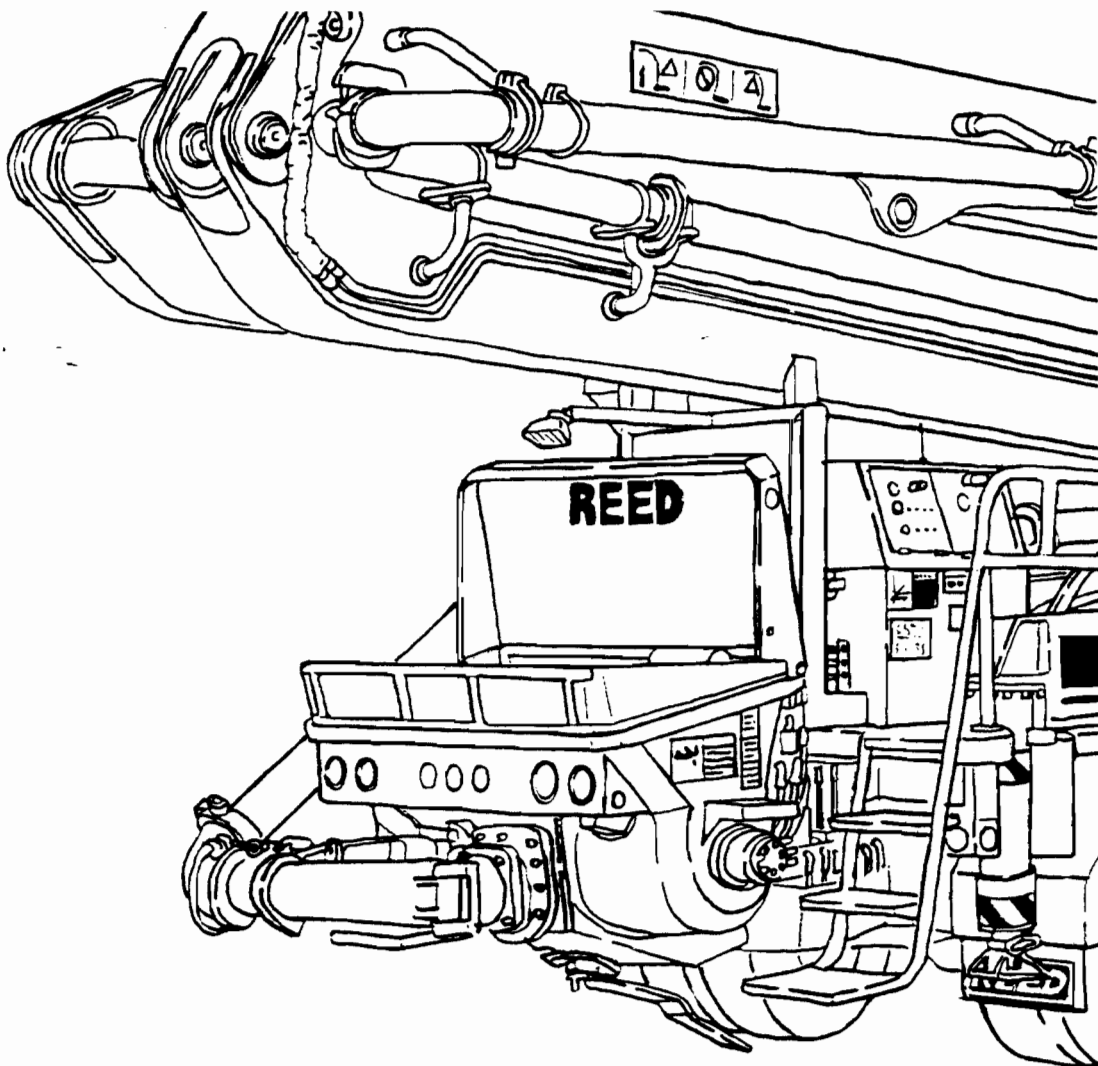

**REED TRUCK MOUNTED CONCRETE BOOM PUMP MODEL XT 36 ILLUSTRATED PARTS MANUAL GROUP 20 HOPPER INSTALLATION CONTAINS THE FOLLOWING FIGURES:**

- |                  |                                      |
|------------------|--------------------------------------|
| <b>FIGURE 00</b> | <b>TABLE OF CONTENTS</b>             |
| <b>FIGURE 01</b> | <b>HOPPER INSTALLATION</b>           |
| <b>FIGURE 02</b> | <b>LUBRICATION PUMP ASSEMBLY</b>     |
| <b>FIGURE 03</b> | <b>CENTRAL LUBRICATION SYSTEM</b>    |
| <b>FIGURE 04</b> | <b>HOPPER VIBRATION ASSEMBLY</b>     |
| <b>FIGURE 05</b> | <b>AGITATOR ASSEMBLY</b>             |
| <b>FIGURE 06</b> | <b>AGITATOR DRIVE MOTOR ASSEMBLY</b> |
| <b>FIGURE 07</b> | <b>HOPPER OUTLET ASSEMBLY</b>        |

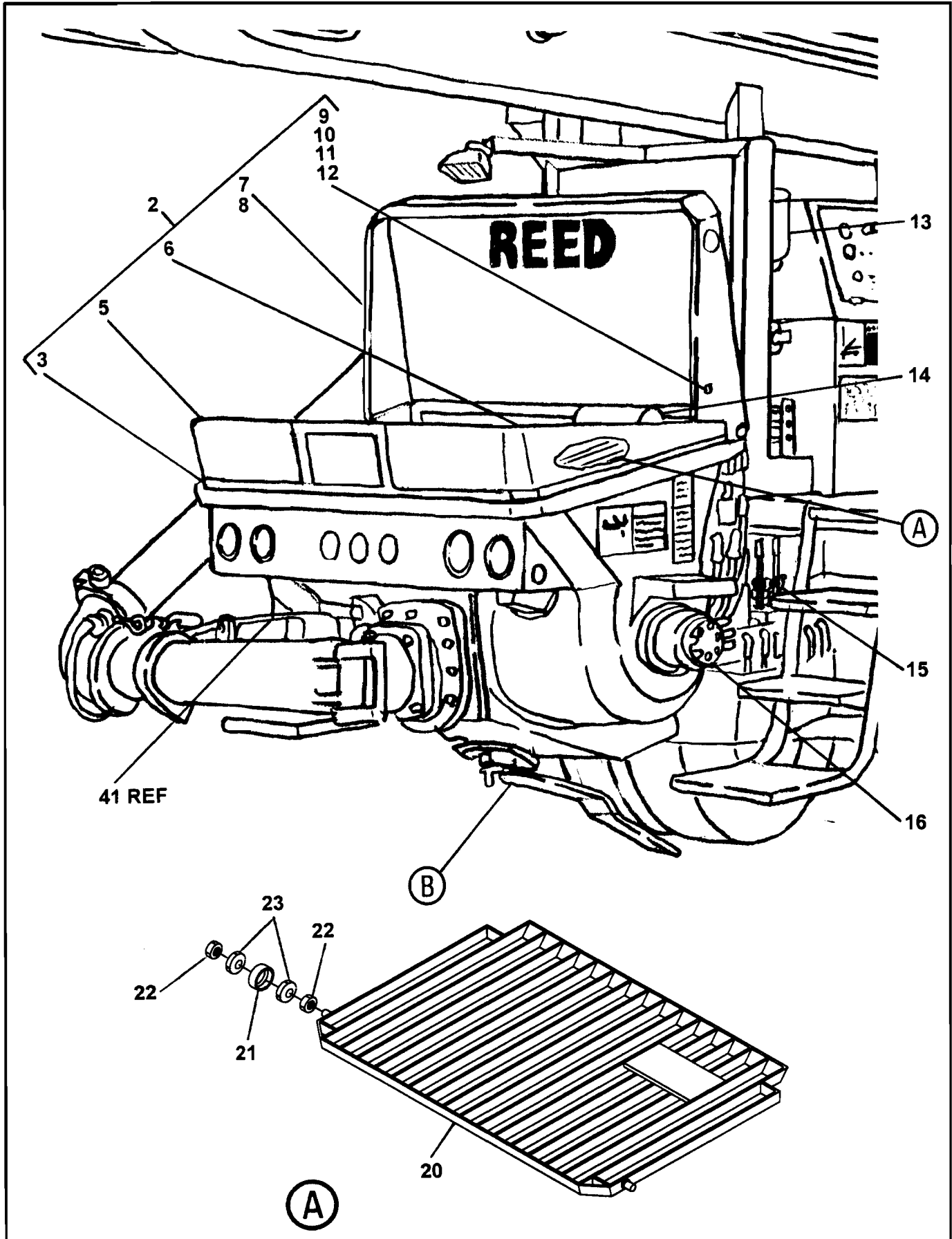



# HOPPER INSTALLATION

**XT 36**  
**PARTS**  
GROUP 20  
FIGURE 01  
PAGE 02

ITEM NO.	REED'S PARTS NO.	DESCRIPTION					QTY
		1	2	3	4	5	
-1	20-01	Installation, Hopper (See Group 10, Figure 01 for NHA)					Ref
2	800419	• Group, Splash Guard					1
3	800398	• • Bar, Splash Guard					1
-4	800402	• • Strip, Silicon 0.53					1
5	800399	• • Rubber Flap, Splash Guard					1
6	800416	• • Rubber, Splash Guard 10 FT					1
7	79056	• • Handle, Splash Guard					1
8	800395	• • Weldment, Splash Guard					1
9	800400	• • Pivot plate, Splash Guard					2
10	800401	• • Plunger, Spring					2
11	800417	• • Pin					1
12	800418	• • Lanyard					1
13	B-184000	• Assembly, Central Lubrication System (See Group 20, Figure 02 for DET)					1
14	71429	• Assembly, Hopper Vibration (See Group 20, Figure 04 for DET)					1
15	W-100124	• Assembly, Agitator/Wash Control Valve					1
-16	B-254120	• Assembly, Agitator (See Group 20, Figure 05 for DET)					1
-17	W-104067	• Buffer, Grid Rubber					4
-18	W-101559	• Washer (attaching parts)					4
19	W-101847	• Nut, Cap (attaching parts)					8
20	B-224035	• Grid					1
21	W101849	• Buffer, Rubber					2
22	W-101559	• Washer					4
23	B-223011	• Nut, Cap					4

DASH (-) ITEM NOT ILLUSTRATED

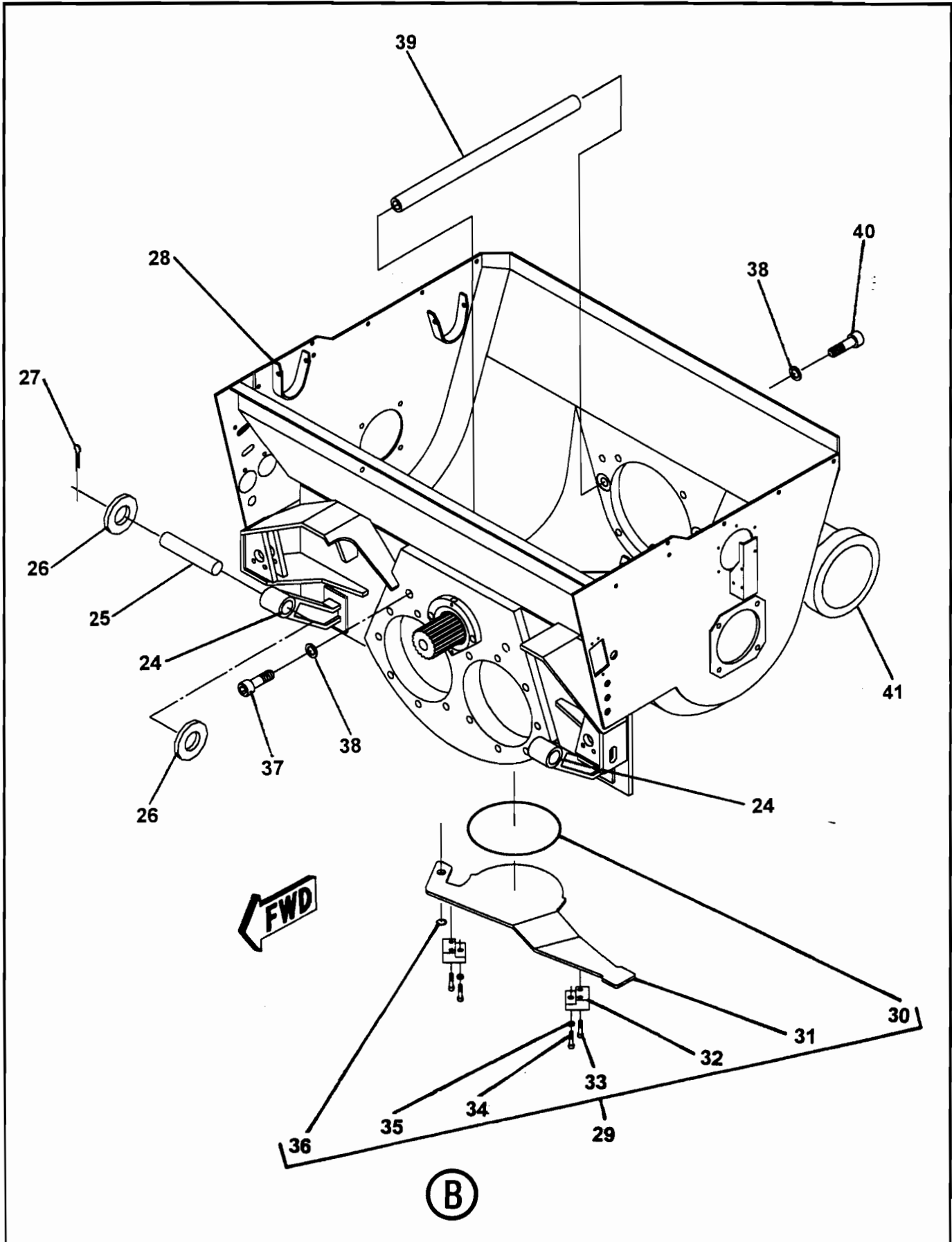

ITEM NO.	REED'S PARTS NO.	DESCRIPTION					QTY
		1	2	3	4	5	
24	W-102489					• Buffer, Rubber	2
25	W-100940					• Pin	2
26	W-103411					• Washer	4
27	-					• Pin, Cotter	4
28	B-173021					• Weldment, Hopper	1
29	B-173085					• Assembly, Cleaning Cover	1
30	W-102908					• • O-Ring, Round Cord	1
31	B-172130					• • Cover, Cleaning	1
32	B-172126					• • Block, Clamping	2
33	W-102855					• • Screw, M20 (attaching parts)	4
34	B-172218					• • Screw, M20 (attaching parts)	2
35	W-102891					• • Nut, Hex M20 (attaching parts)	2
36	W-102864					• • Ring, Lock	1
37	W-103074					• Screw, Hex	2
38	W-102331					• Washer	4
39	B-174075					• Rod, Tie	2
40	W-103073					• Screw, Hex M24	2
41	20-07					• Assembly, Hopper Outlet (See Group 20, Figure 07 for DET)	1

DASH (-) ITEM NOT ILLUSTRATED

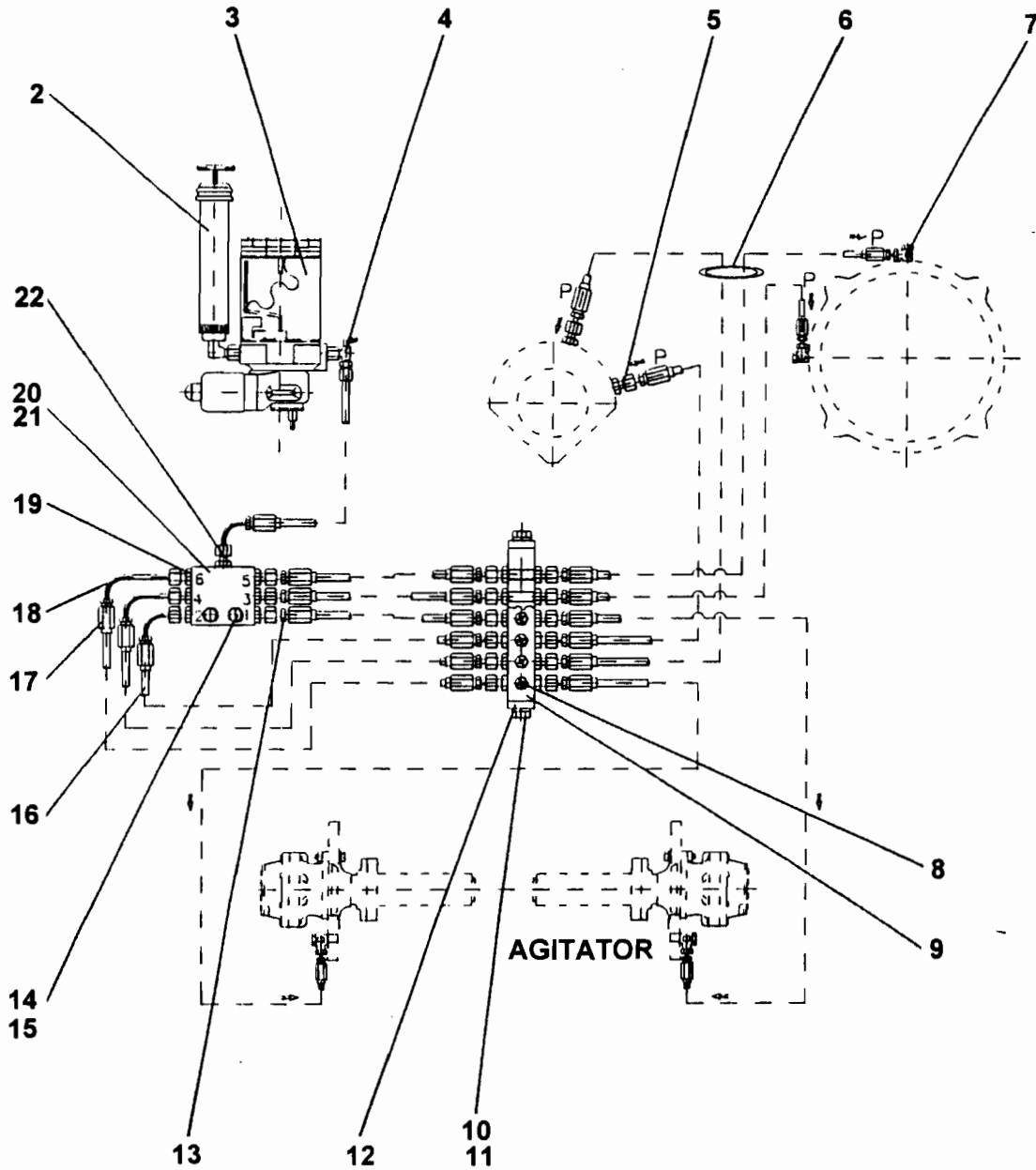



**REED****CENTRAL LUBRICATION SYSTEM****XT 36**  
**PARTS**  
GROUP 20  
FIGURE 02  
PAGE 02

ITEM NO.	REED'S PARTS NO.	DESCRIPTION					QTY
		1	2	3	4	5	
-1	B-184000	System, Central Lubrication (See Group 20, Figure 01 for NHA)					Ref
2	78532	• Gun, Grease					1
3	800065	• Assembly, Lubrication Pump (See Group 20, Figure 03 for DET)					1
4	W-103198	• Valve, Safety					1
5	W-100546	• Coupling, Straight Male Stud					14
6	W-103107	• Tie, Cable					30
7	W-102884	• Elbow, Throttle Free benjo					4
8	W-100303	• Nipple, Grease					6
9	B-184001	• Strip, Lubrication					1
10	W-102873	• Screw, M8					2
11	W-102205	• Washer, A8 Spring					2
12	B-184002	• Plate, Lubrication Mechanism					2
13	W-100253	• Piece, Hose Connection					24
14	W-103847	• Screw, M6 Hex					2
15	W-103000	• Washer, A6 Spring					2
16	W-100255	• Pipe, Plastic					
17	W-100254	• Sleeve, Threaded					30
18	W -102643	• Sleeve, 90 Threaded					30
19	W100299	• Valve, Pipe Stroke					6
20	W-100298	• Distributor, Lubrication					1
21	B-184003	• Plate, Lubrication Distributor Tap					1
22	W-100302	• Coupling, Straight Male Stud					1

DASH (-) ITEM NOT ILLUSTRATED

REVISION:

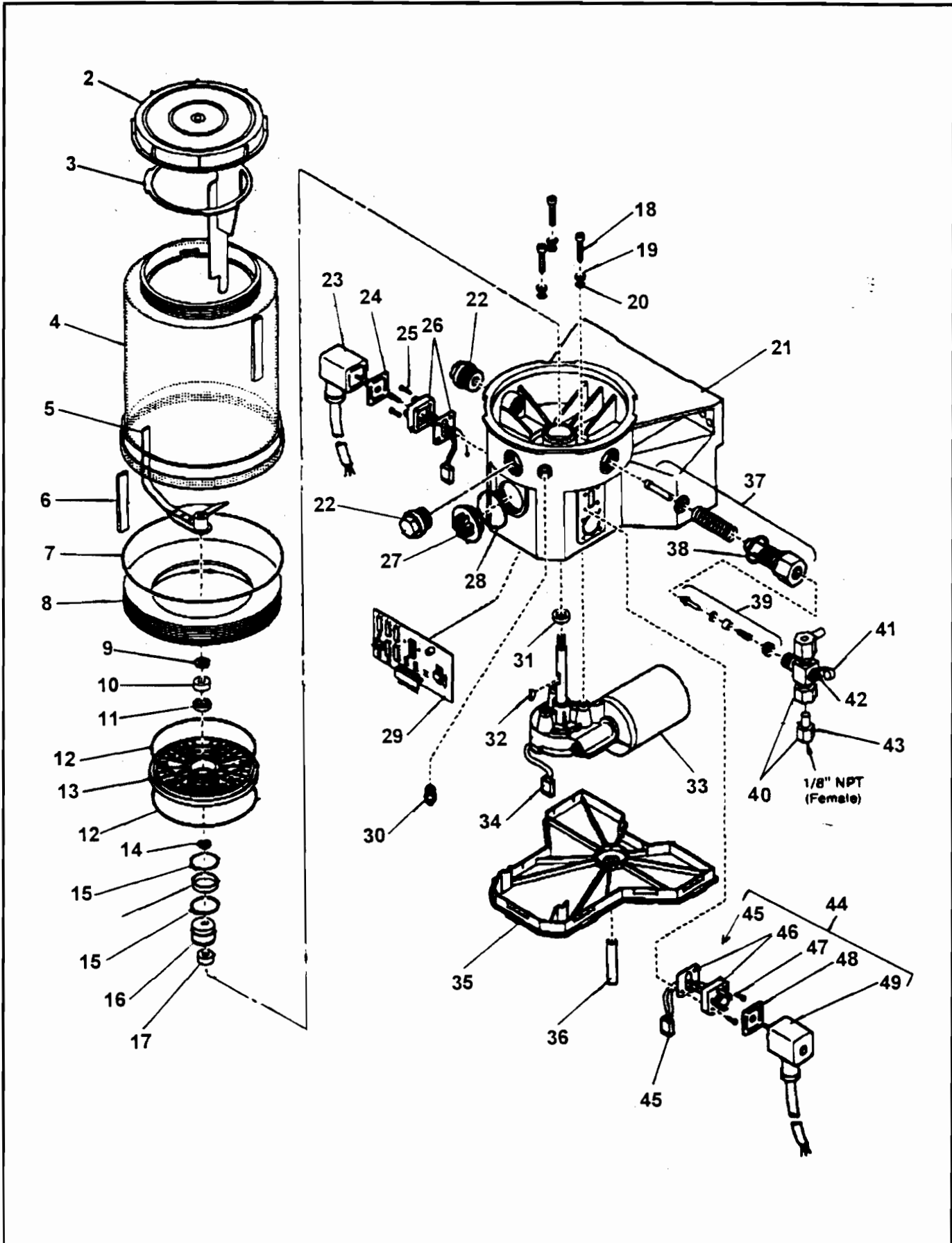

<b>ITEM NO.</b>	<b>REED'S PARTS NO.</b>	<b>DESCRIPTION</b>	<b>QTY</b>
-1	800065	Assembly, Lubrication Pump (See Group 20, Figure 02 for NHA)	Ref
2		• Lid	1
3		• Paddle, Fixed	1
4		• Reservoir	1
5		• Paddle, Stirring	1
6		• Hose	1
7		• O-Ring	1
8		• Adapter	1
9		• Washer	1
10		• Ring, Bearing	2
11		• Bearing	1
12		• O-Ring	2
13		• Plate, Intermediate	1
14		• Shim	1
15		• Ring, Snap	2
16		• Ring, Inner	1
17		• Cam, Eccentric	1
18		• Screw	3
19		• Washer	3
20		• O-Ring	3
21		• Housing, Pump	1
22		• Plug, Closure	2
23		• Socket with Cord	1
24		• Packing, Flat	1
25		• Screw	4
26		• Plug	1
27		• Plug, Sealing	1
28		• O-Ring	1
29		• Board, Printed Circuit	1
30		• Fitting, Grease	1
31		• Seal, Radial	1
32		• Key, Wood Ruff	1
33		• Motor, 12 VDC	1
34		• Plug, Motor	1
35		• Cover, Housing	1

DASH (-) ITEM NOT ILLUSTRATED

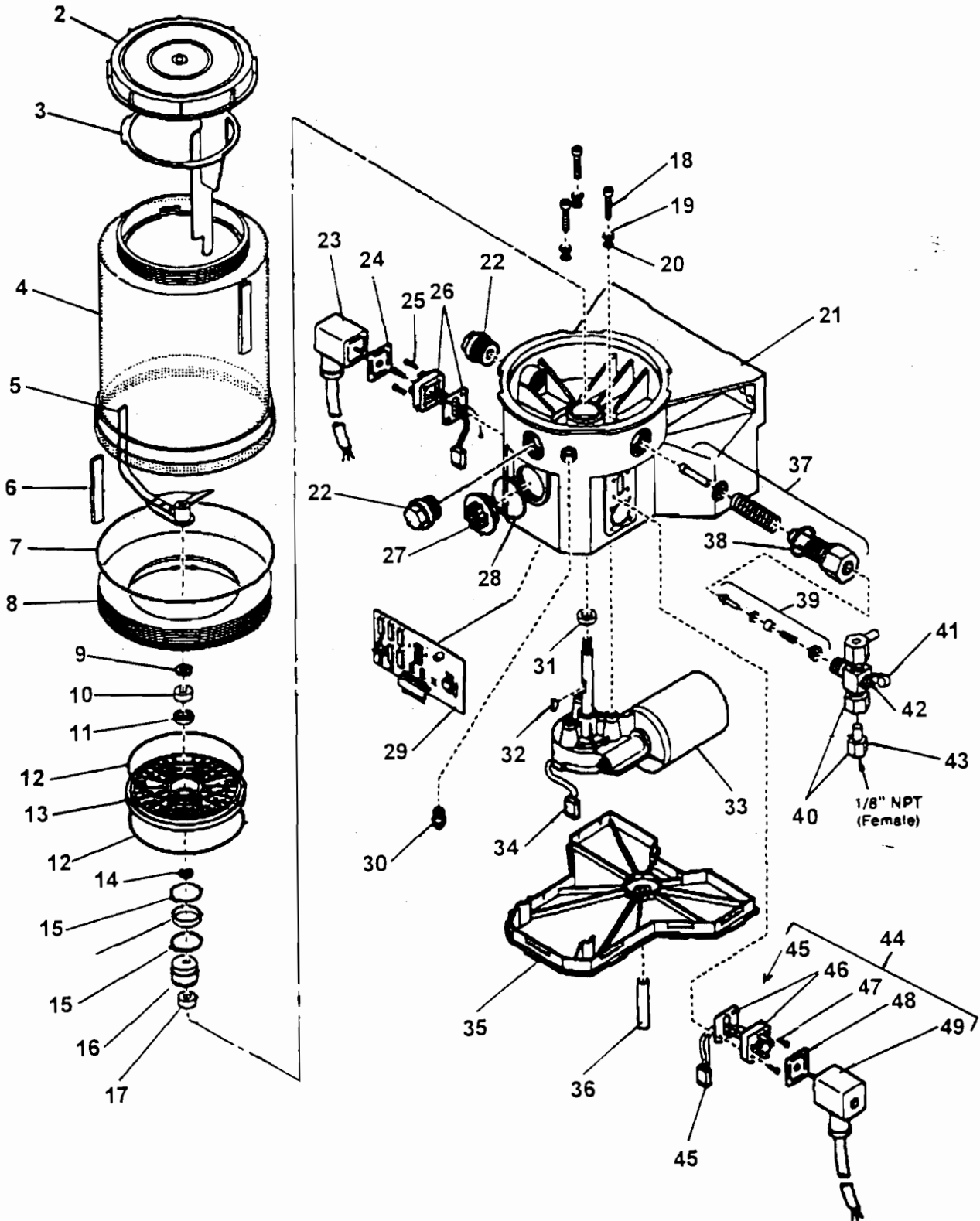



# LUBRICATION PUMP ASSEMBLY

**XT 36**  
**PARTS**  
GROUP 20  
FIGURE 03  
PAGE 04

ITEM NO.	REED'S PARTS NO.	DESCRIPTION					QTY
		1	2	3	4	5	
36		• Hose					1
37		• Element, Pump					1
38		• Gasket					1
39		• Valve, Check					1
40		• Assembly, Pressure Release					1
41		• Cap, Grease					1
42		• Fitting, Grease					1
43		• Adapter for Relief					1
44		• Assembly, Optional Pressure Relief Valve					1
45		• • Cord, Optional Power					1
46		• • Plug, Optional					1
47		• • Screw, Optional					4
48		• • Packing, Optional Flat					1
49		• • Socket, Optional					1

DASH (-) ITEM NOT ILLUSTRATED



# HOPPER VIBRATOR ASSEMBLY

XT 36  
PARTS  
GROUP 20  
FIGURE 04  
PAGE 01

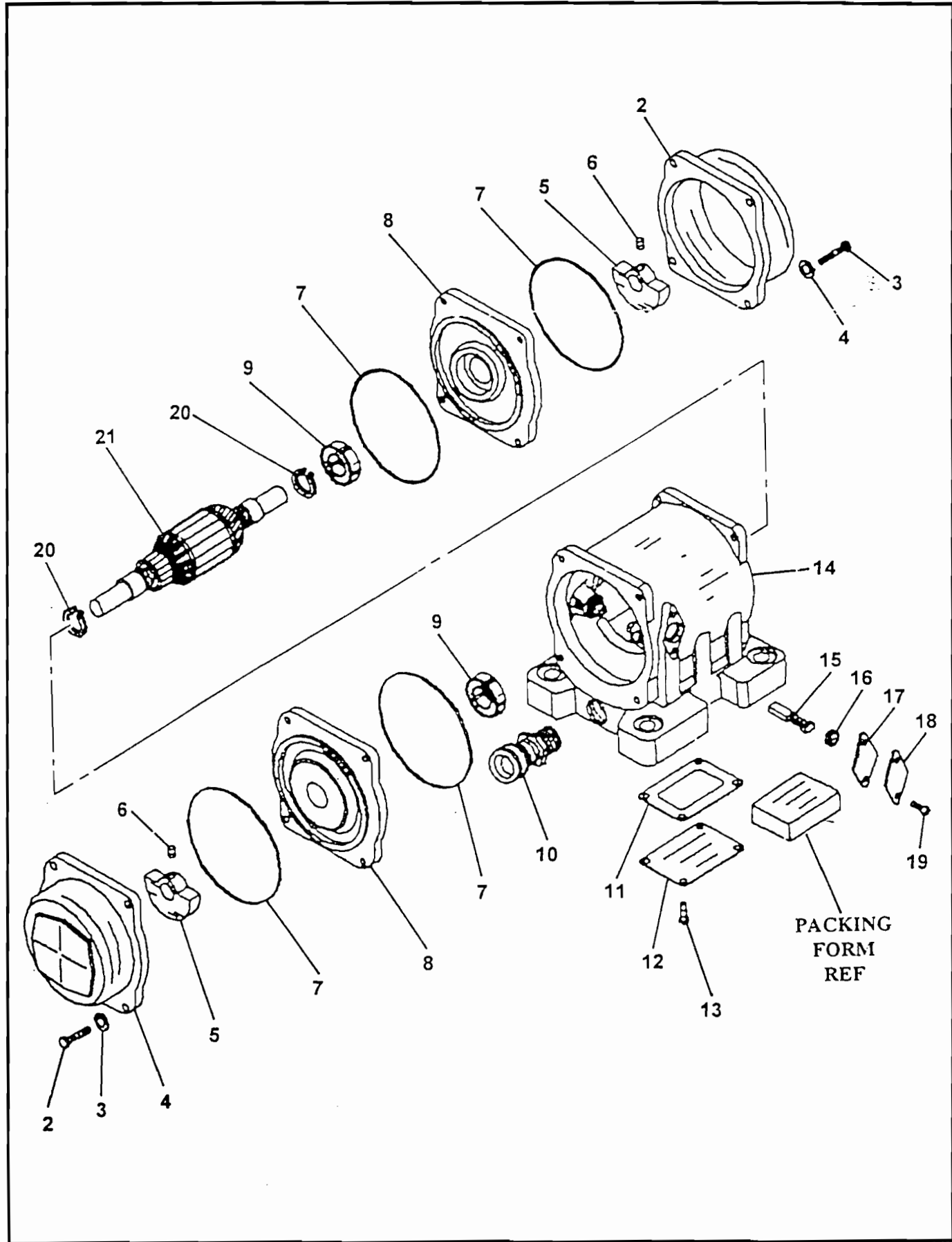

REVISION:



# HOPPER VIBRATOR ASSEMBLY

**XT 36**  
**PARTS**  
GROUP 20  
FIGURE 04  
PAGE 02

ITEM NO.	REED'S PARTS NO.	DESCRIPTION					QTY
		1	2	3	4	5	
-1	71429	Assembly, Hopper Vibrator (See Group 20, Figure 01 for NHA)					Ref
2		• Cap, End					2
3		• Bolt (attaching parts)					8
4		• Washer, Lock (attaching parts)					8
5		• Weight					2
6		• Screw, Set (attaching parts)					2
7		• O-Ring					4
8		• Bell, End					2
9		• Bearing					2
10		• Holder, Cord					1
11		• Gasket					1
12		• Cover, Box					1
13		• Screw (attaching parts)					4
14		• Sub-Assembly, Housing					1
15		• Brush					1
16		• Cap, Brush					2
17		• Gasket					2
18		• Cover, Brush					2
19		• Screw (attaching parts)					4
20		• Ring, Snap					2
21		• Assembly, Armature					1

DASH (-) ITEM NOT ILLUSTRATED

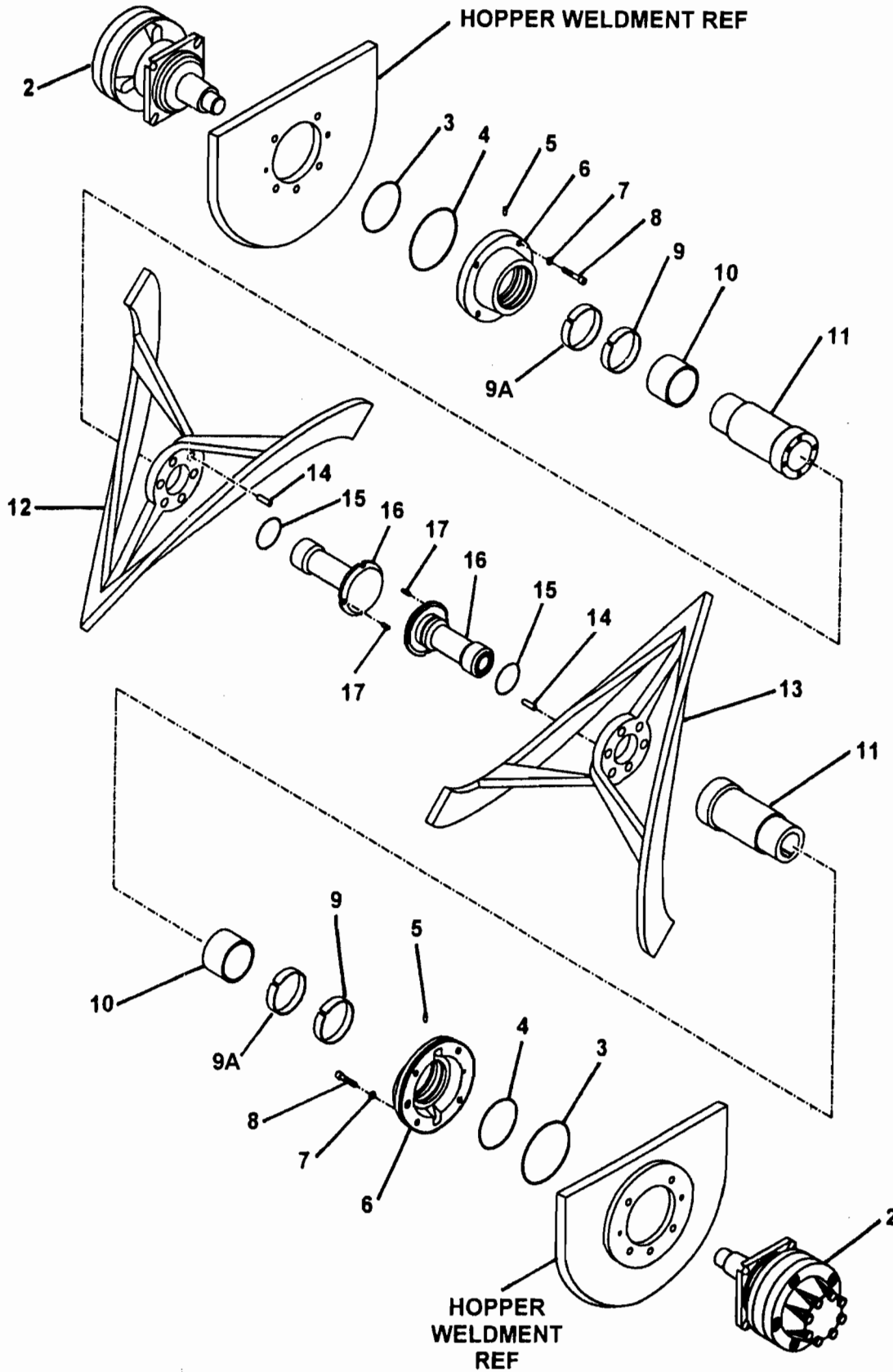



ITEM NO.	REED'S PARTS NO.	DESCRIPTION					QTY
		1	2	3	4	5	
-1	B-254120	Assembly, Agitator (See Group 20, Figure 01 for NHA)					Ref
2	W-101240	• Assembly, Agitator Drive Motor (See Group 20, Figure 08 for DET)					1
3	W-103064	• O-Ring					2
4	W-103063	• O-Ring					2
5	W-1004909	• Screw, M5 Set					2
6	B-254101	• Assembly, Flange					2
7	W-102962	• Washer					8
8	W-103062	• Screw, M12 Hex					8
9	W-102544	• Ring, Groove-Outer					2
9A	B-253029	• Ring, Groove-Inner					2
10	B-254104	• Sleeve, Wear					2
11	B-254102	• Shaft					2
12	B-254105	• Agitator, Left					1
13	B-254106	• Agitator, Right					1
14	W-103065	• Pin 10m					12
15	W-103249	• O-Ring					2
16	B-254103	• Nut					2
17	W-103106	• Sleeve, Clamping					4

DASH (-) ITEM NOT ILLUSTRATED



# AGITATOR DRIVE MOTOR ASSEMBLY

XT 36  
PARTS  
GROUP 20  
FIGURE 06  
PAGE 01

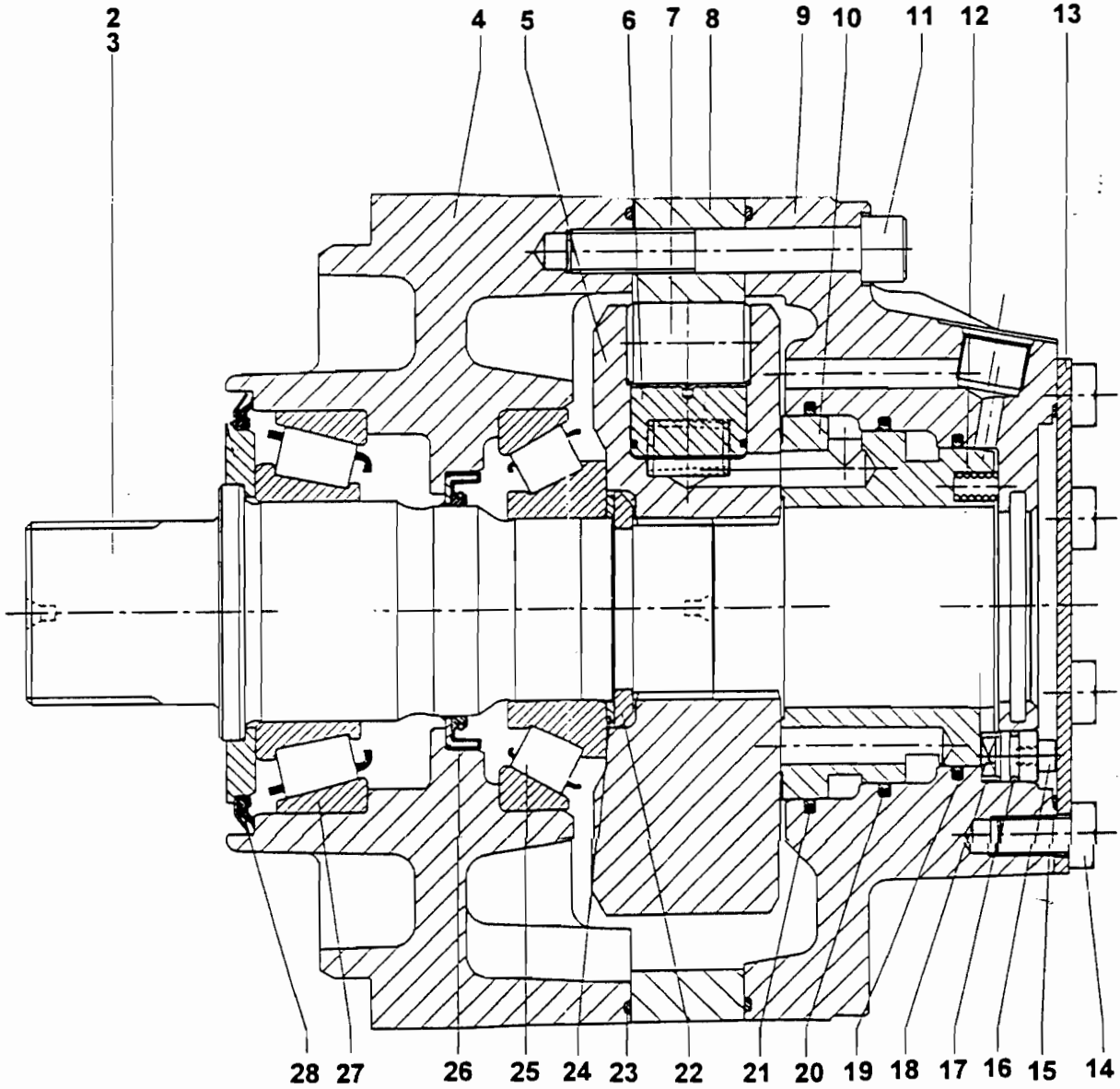

REVISION:

**REED****AGITATOR DRIVE MOTOR ASSEMBLY****XT 36**  
**PARTS**  
GROUP 20  
FIGURE 06  
PAGE 02

ITEM NO.	REED'S PARTS NO.	DESCRIPTION					QTY
		1	2	3	4	5	
-1	W-101240	Assembly, Agitator Drive Motor (See Group 20, Figure 05 for NHA)					Ref
2	-	• Assembly, Auger Drive Motor					1
3		• Shaft					1
4		• Case, Front					1
5		• Block, Cylinder					1
6		• Piston					8
7		• Roller					8
8		• Cam					1
9		• Case, Rear					1
10		• Ring, Distributor					1
11		• Screw, Cap M12					12
12		• Spring					6
13		• Plate, Cover					1
14		• Screw, Hex M10					8
15		• O-Ring					1
16		• Screw, Cap M5					1
17		• O-Ring					1
18		• Pin, Stop					1
19		• Seal, Rod					1
20		• Seal, Rod					1
21		• Seal, Rod					1
22		• Ring, Split					1
23		• O-Ring					2
24		• Washer					1
25		• Bearing					1
26		• Seal, Shaft					1
27		• Bearing					1
28		• Seal, Face					1

DASH (-) ITEM NOT ILLUSTRATED

REVISION:



# HOPPER OUTLET ASSEMBLY

XT 36  
PARTS  
GROUP 20  
FIGURE 07  
PAGE 01

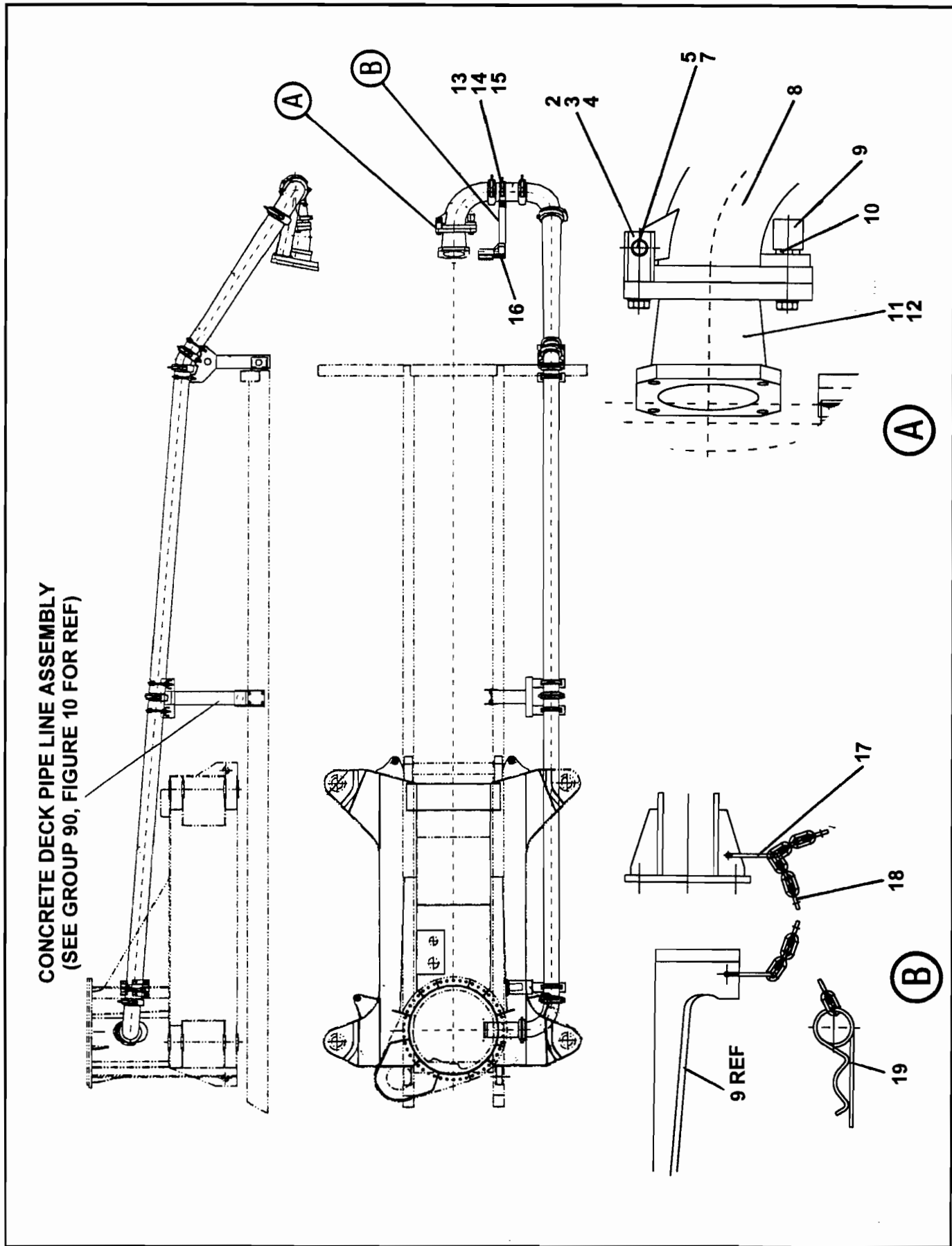

REVISION:

ITEM NO.	REED'S PARTS NO.	DESCRIPTION					QTY
		1	2	3	4	5	
-1	20-07	Assembly, Hopper Outlet (See Group 20, Figure 01 for NHA)					Ref
2	B-194049	• Hinge					2
3	W-102848	• Screw, M24 Hex Head					3
4	W-102331	• Washer					3
5	W-100694	• Ring, Snap					2
-6	B-194065	• Sub- Assembly, Hopper Outlet					1
7	B-194050	• • Bolt					1
8	B-191015	• • Elbow, Reducer					1
9	B-194046	• • Wedge, Locking					1
10	B-194045	• • Bolt, Locking					1
11	B-191010	• • Reducer					1
12	W-104025	• • O-Ring, Hopper Elbow					1
13	W-101779	• • Coupling, 6 Inch Clamp					3
14	W-100690	• • Elbow, 6 Inch					1
15	W-101545	• • O-Ring					3
16	B-194053	• • Coupling, Delivery Line Snap					1
17	W-103731	• S-Hook					2
18	W-103732	• Chain					1
19	W-103733	• Pin, Spring					1

DASH (-) ITEM NOT ILLUSTRATED

**REED**

**MODEL XT 36 TRUCK MOUNTED  
CONCRETE BOOM PUMP  
ILLUSTRATED PARTS MANUAL**

**XT 36  
PARTS  
GROUP 20  
FIGURE 08  
PAGE 01**

THIS PAGE INTENTIONALLY LEFT BLANK.

**REED TRUCK MOUNTED CONCRETE BOOM PUMP MODEL XT 36 ILLUSTRATED PARTS MANUAL GROUP 30 HYDRAULIC TANK INSTALLATION CONTAINS THE FOLLOWING FIGURES:**

<b>FIGURE 00</b>	<b>TABLE OF CONTENTS</b>
<b>FIGURE 01</b>	<b>TANK INSTALLATION (BEF FEB 2000)</b>
<b>FIGURE 02</b>	<b>TANK INSTALLATION (AFT MAR 2000)</b>
<b>FIGURE 03</b>	<b>WATER TANK ASSEMBLY (BEF FEB 2000)</b>
<b>FIGURE 04</b>	<b>WATER SYSTEM GROUP (AFT MAR 2000)</b>
<b>FIGURE 05</b>	<b>WASH WATER PUMP ASSEMBLY (BEF FEB 2000)</b>
<b>FIGURE 06</b>	<b>WASH WATER PUMP ASSEMBLY (AFT MAR 2000)</b>
<b>FIGURE 07</b>	<b>WATER PUMP MOTOR ASSEMBLY (BEF FEB 2000)</b>
<b>FIGURE 08</b>	<b>WATER PUMP MOTOR ASSEMBLY (AFT MAR 2000)</b>
<b>FIGURE 09</b>	<b>HYDRAULIC TANK ASSEMBLY (BEF FEB 2000)</b>
<b>FIGURE 10</b>	<b>HYDRAULIC TANK ASSEMBLY (AFT MAR 2000)</b>
<b>FIGURE 11</b>	<b>OIL COOLER MANIFOLD ASSEMBLY</b>

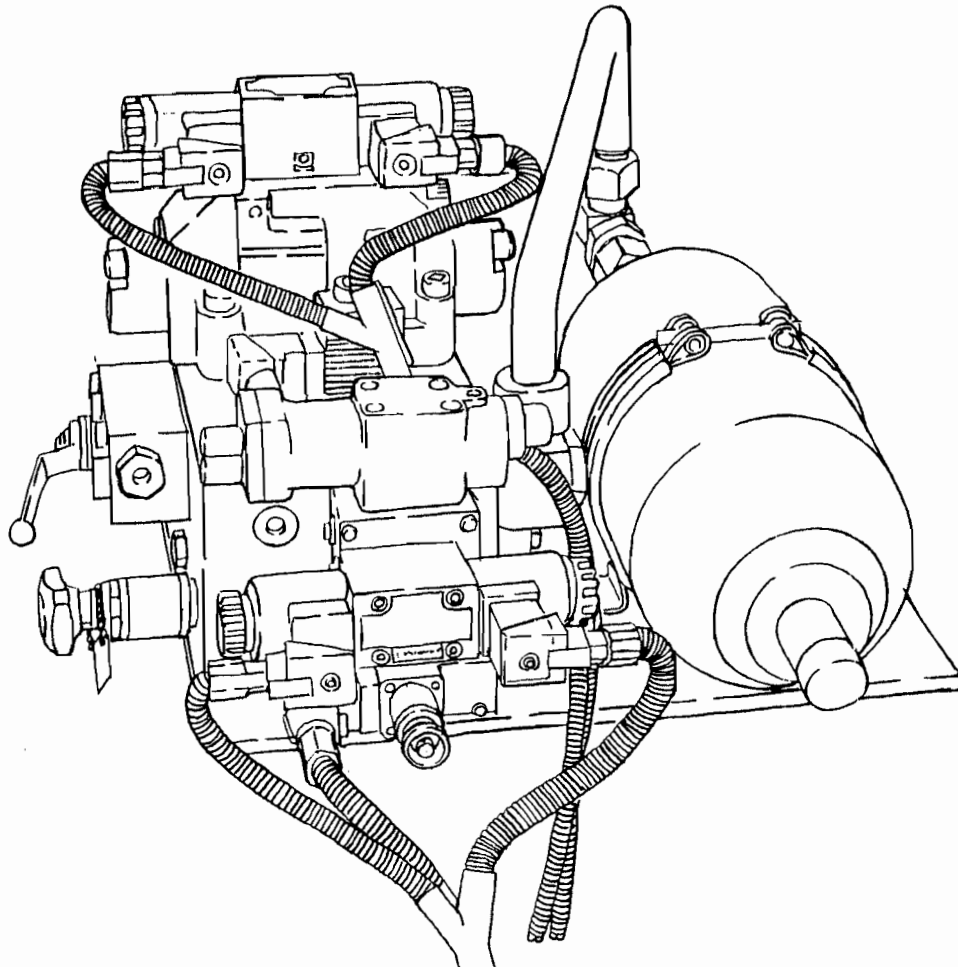

## TANK INSTALLATION (BEFORE FEBRUARY 2000)

BEFORE FEBRUARY 2000

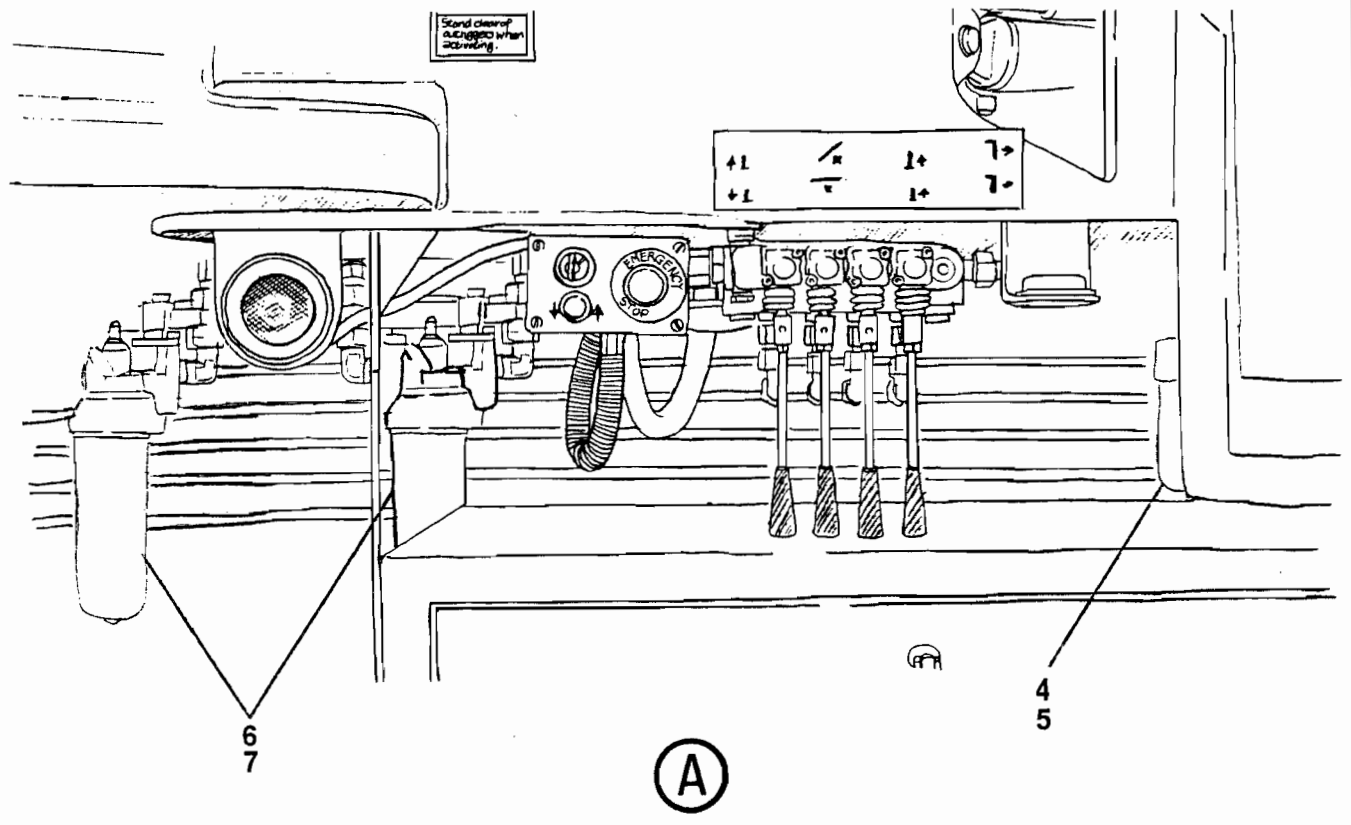
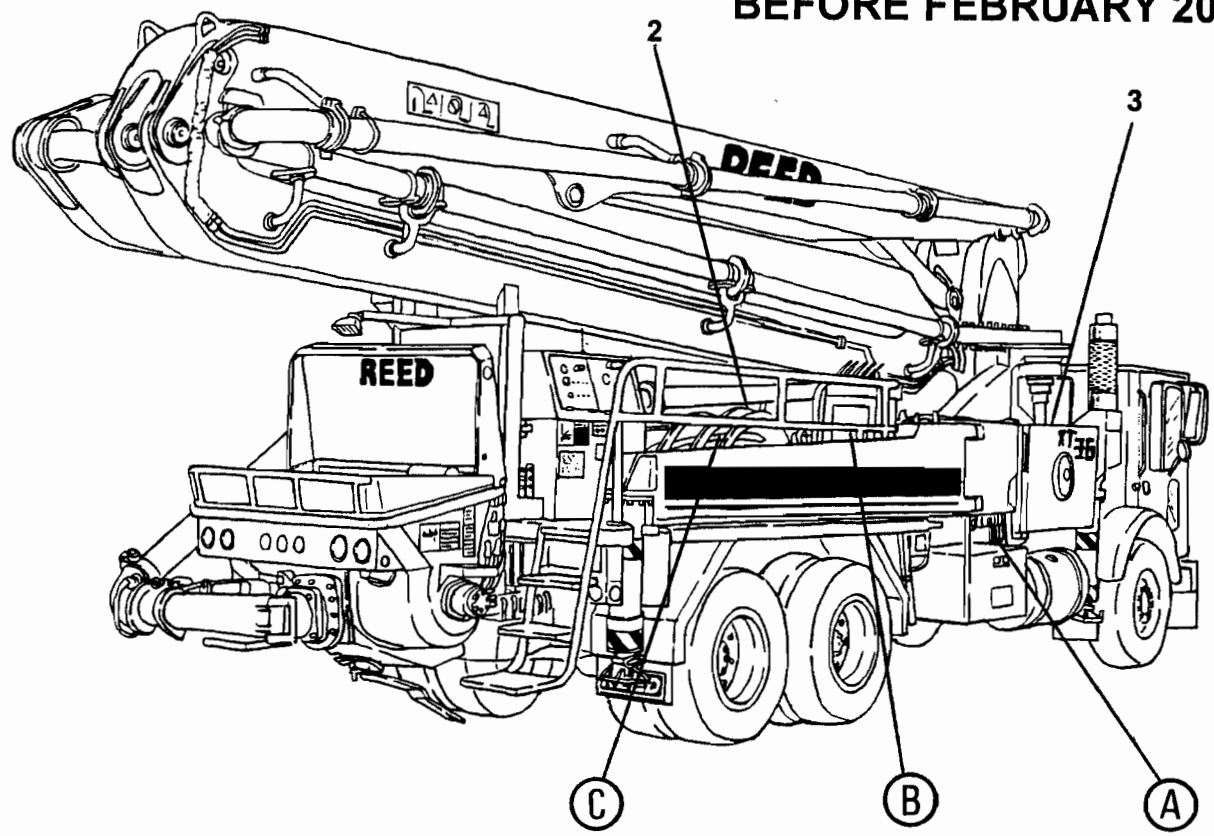





# TANK INSTALLATION (BEFORE FEBRUARY 2000)

**XT 36**  
**PARTS**  
GROUP 30  
FIGURE 01  
PAGE 02

## BEFORE FEBRUARY 2000

ITEM NO.	REED'S PARTS NO.	DESCRIPTION					QTY
		1	2	3	4	5	
-1	30-01	Installation, Tank (Bef Feb 2000) (See Group 10, Figure 01 for NHA)					Ref
2	800748	• Assembly, Water Tank (Bef Feb 2000) (See Group 30, Figure 03 for DET)					1
3	800664	• Assembly, Hydraulic Tank (Bef Feb 2000) (See Group 30, Figure 09 for DET)					1
4	73300	• Assembly, Hydraulic Filter					2
5	73303	• • Element, Hydraulic Filter					1
6	W-105526	• Assembly, Boom High Pressure Filter					1
7	800446	• • Element, Boom High Pressure Filter					1
8	800651	• Assembly, Hydraulic Oil Cooler					1
9	79276	• Gauge, Return Filter Indicator					2
10	79245	• Assembly, Return Filter					1
11	79269	• • Element, Return Filter					2
12	W-104847	• Assembly, Swing Tube Manifold					1
13	W-105573	• Assembly, Swing Tube Circuit Solenoid Valve					1
14	W-105581	• • Pilot, Solenoid Valve					1
15	W-105576	• • • Coil, Swing Tube Circuit Solenoid Valve					2
16	W-105572	• Cartridge, Solenoid Valve					1
17	W-105605	• • Coil					1
18	W-105579	• Valve, HP Limiter					1
19	W-103616	• Accumulator					1
20	71460	• Kit, Accumulator Charge (Optional Item) (See Group 80, Figure 02 for REF)					1
21	73171	• Bracket, Accumulator					A/R
22	W-105582	• Valve, Proportional Pilot					1
23	W-105606	• • Coil					1
24	W-105581	• Assembly, Pump Control Solenoid Valve					1
25	W-105576	• • Coil, Pump Control Solenoid Valve					2
26	W-104846	• Assembly, Pump Control Manifold					1
27	W-105570	• Cartridge, Relief Valve					1
28	W-105577	• Cartridge, Check Valve					1
29	W-105578	• Valve, Ball					1
30	W-104691	• Plug					4

DASH (-) ITEM NOT ILLUSTRATED

**BEFORE FEBRUARY 2000**

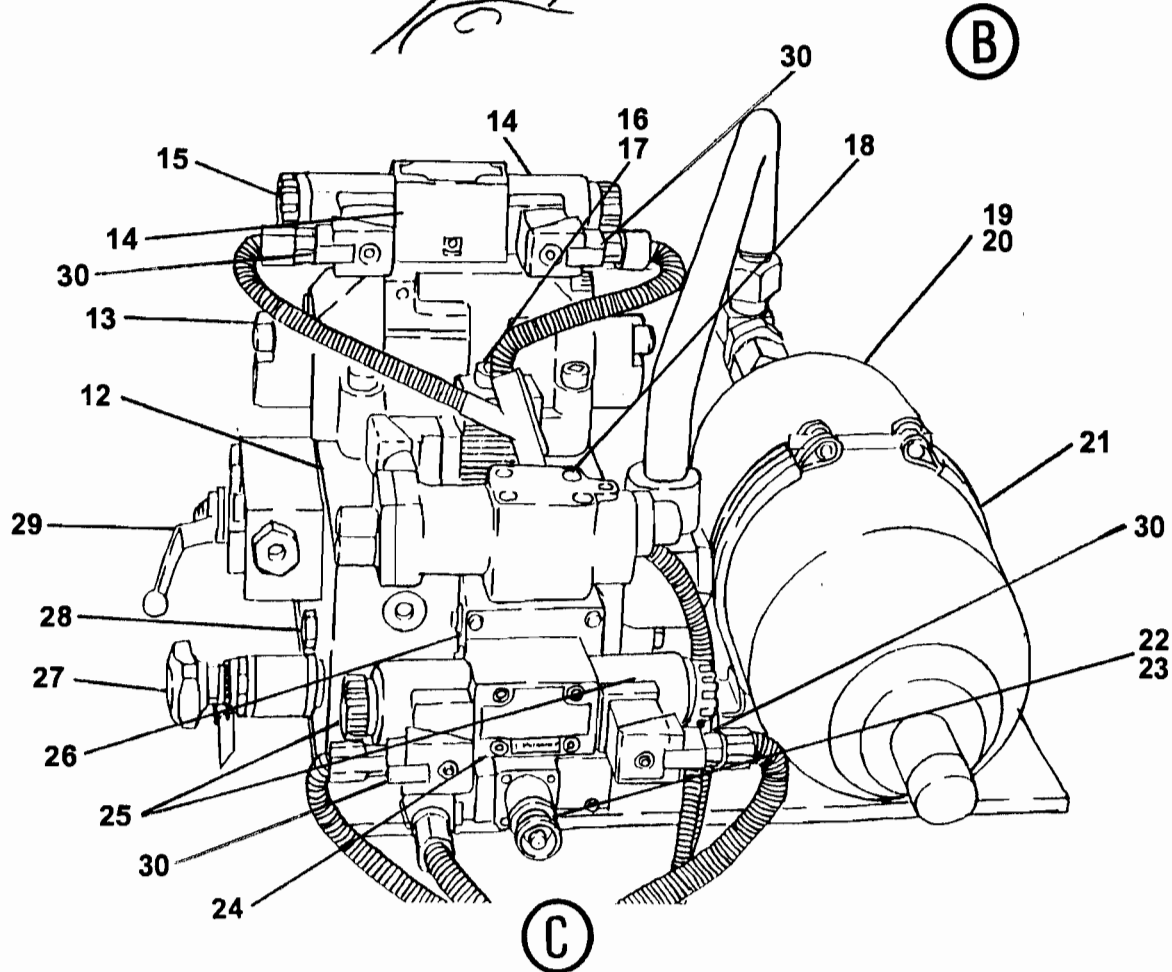
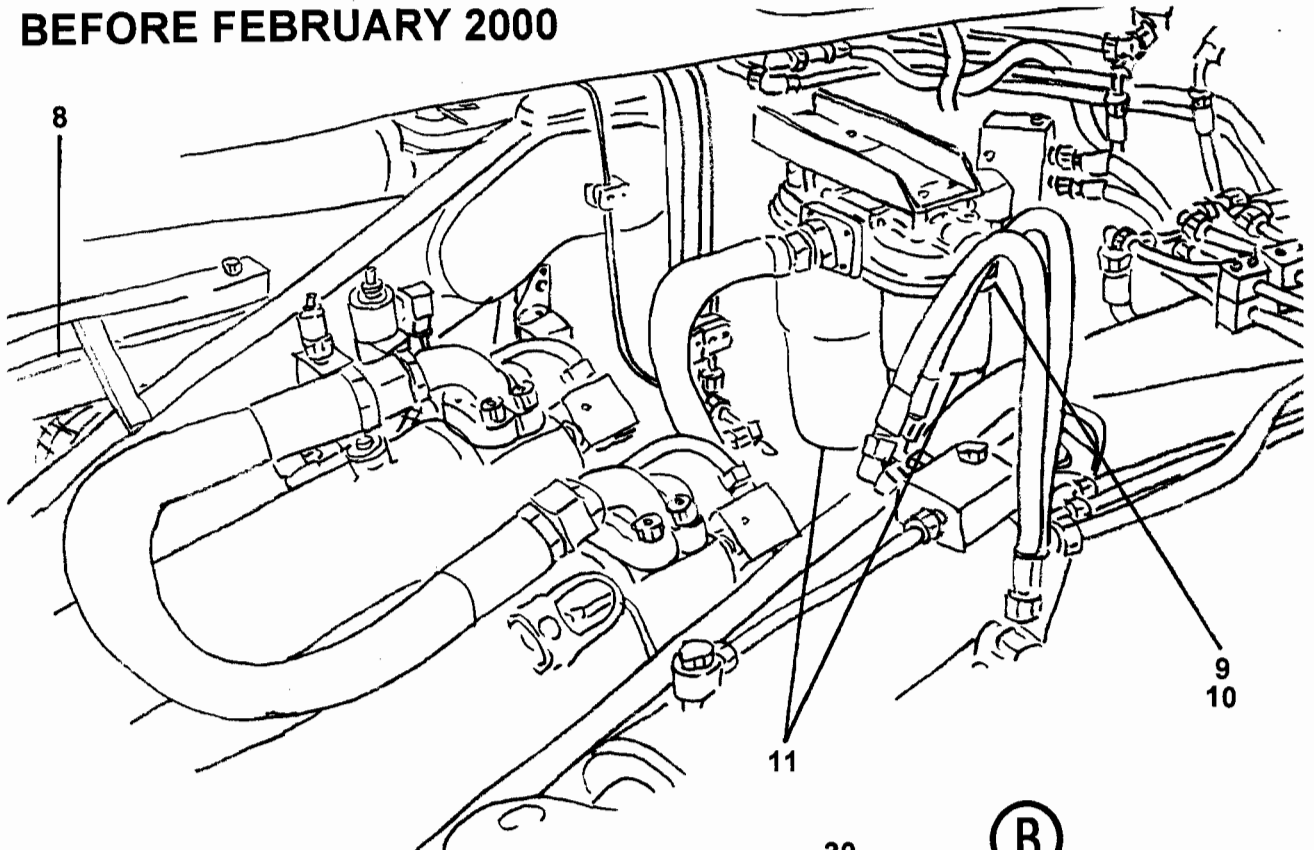



# TANK INSTALLATION (BEFORE FEBRUARY 2000)

**XT 36**  
**PARTS**  
GROUP 30  
FIGURE 01  
PAGE 04

## BEFORE FEBRUARY 2000

ITEM NO.	REED'S PARTS NO.	DESCRIPTION					QTY
		1	2	3	4	5	
-1	30-01	Installation, Tank (Bef Feb 2000) (See Group 10, Figure 01 for NHA)					Ref
2	800748	• Assembly, Water Tank (Bef Feb 2000) (See Group 30, Figure 03 for DET)					1
3	800664	• Assembly, Hydraulic Tank (Bef Feb 2000) (See Group 30, Figure 09 for DET)					1
4	73300	• Assembly, Hydraulic Filter					2
5	73303	• • Element, Hydraulic Filter					1
6	W-105526	• Assembly, Boom High Pressure Filter					1
7	800446	• • Element, Boom High Pressure Filter					1
8	800651	• Assembly, Hydraulic Oil Cooler					1
9	79276	• Gauge, Return Filter Indicator					2
10	79245	• Assembly, Return Filter					1
11	79269	• • Element, Return Filter					2
12	W-104847	• Assembly, Swing Tube Manifold					1
13	W-105573	• Assembly, Swing Tube Circuit Solenoid Valve					1
14	W-105581	• • Pilot, Solenoid Valve					1
15	W-105576	• • • Coil, Swing Tube Circuit Solenoid Valve					2
16	W-105572	• Cartridge, Solenoid Valve					1
17	W-105605	• • Coil					1
18	W-105579	• Valve, HP Limiter					1
19	W-103616	• Accumulator					1
20	71460	• Kit, Accumulator Charge (Optional Item) (See Group 80, Figure 02 for REF)					1
21	73171	• Bracket, Accumulator					A/R
22	W-105582	• Valve, Proportional Pilot					1
23	W-105606	• • Coil					1
24	W-105581	• Assembly, Pump Control Solenoid Valve					1
25	W-105576	• • Coil, Pump Control Solenoid Valve					2
26	W-104846	• Assembly, Pump Control Manifold					1
27	W-105570	• Cartridge, Relief Valve					1
28	W-105577	• Cartridge, Check Valve					1
29	W-105578	• Valve, Ball					1
30	W-104691	• Plug					4

DASH (-) ITEM NOT ILLUSTRATED

## TANK INSTALLATION (AFTER MARCH 2000)

**AFTER MARCH 2000**

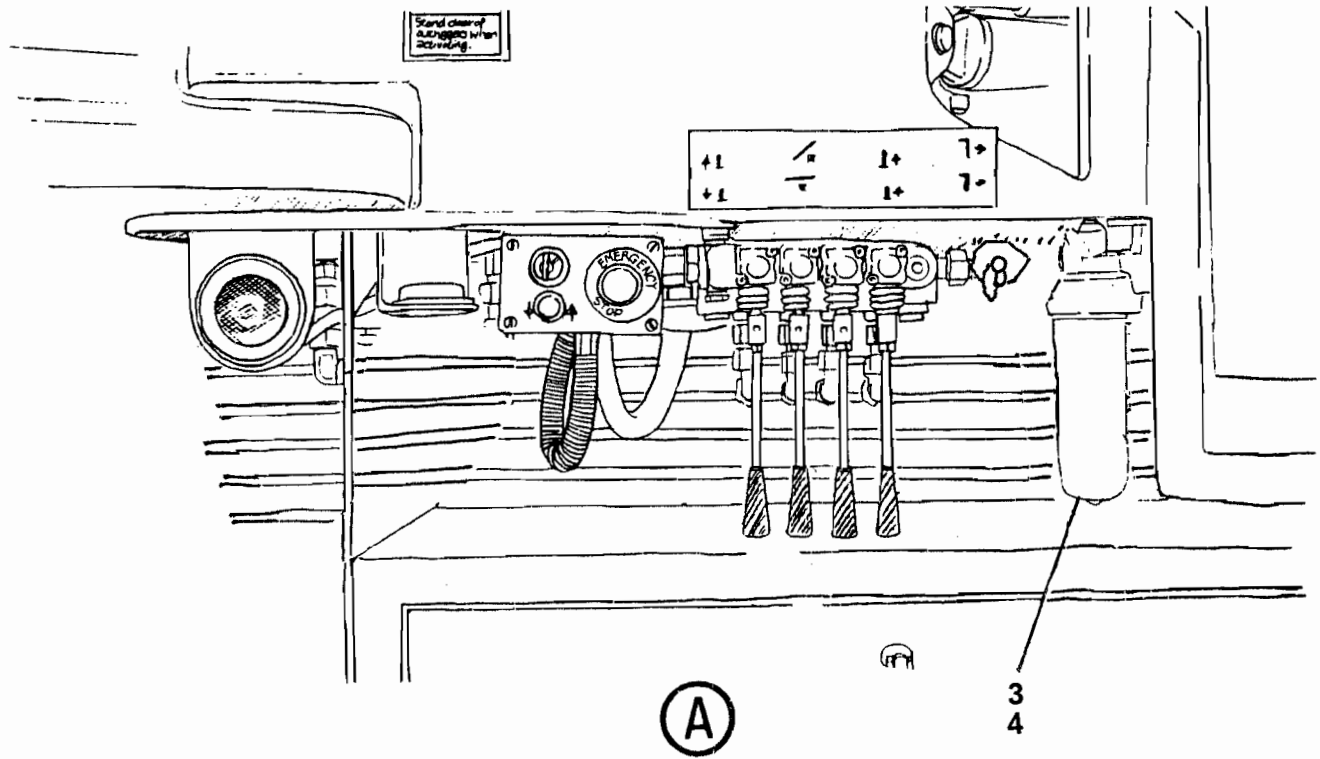
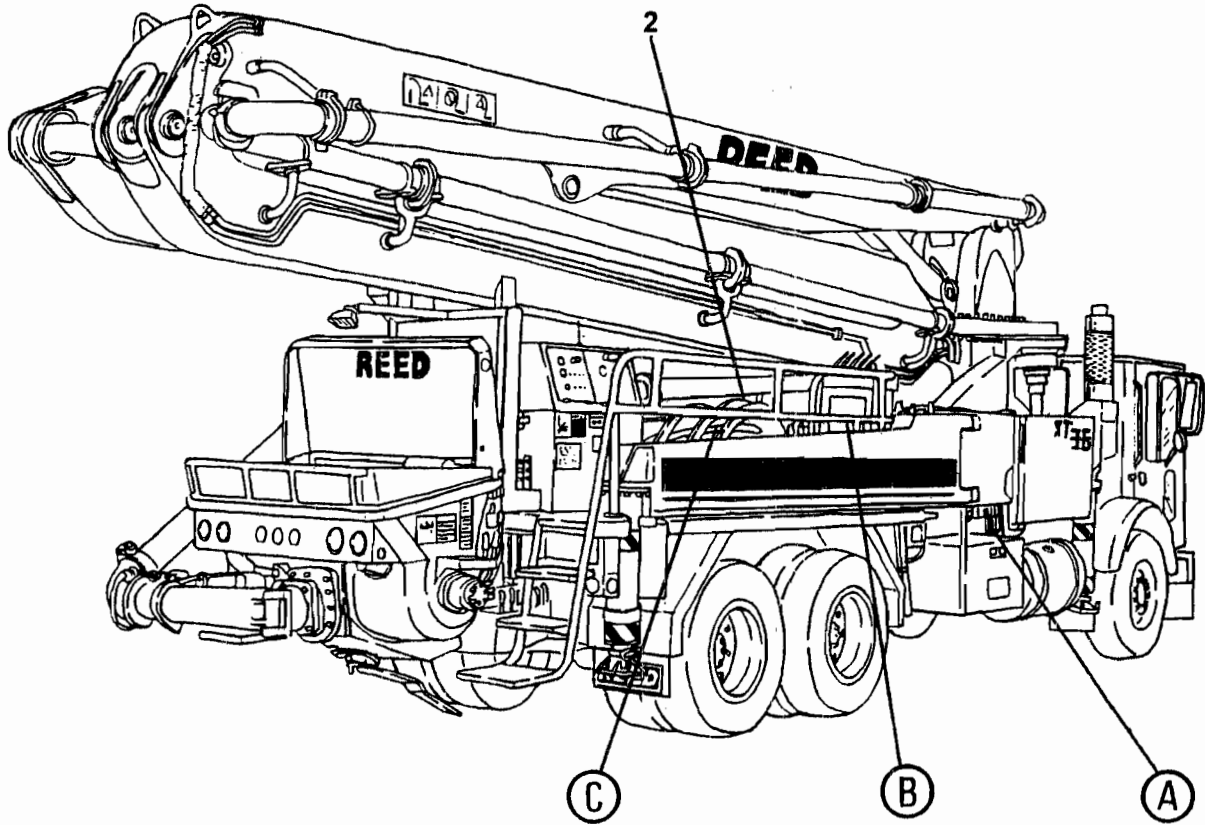

ITEM NO.	REED'S PARTS NO.	DESCRIPTION					QTY
		1	2	3	4	5	
-1	30-02	Installation, Tank (Aft Mar 2000) (See Group 10, Figure 01 for NHA)					Ref
2	30-04	• Group, Water System (Aft Mar 2000) (See Group 30, Figure 04 for DET)					1
3	W-105526	• Assembly, Boom High Pressure Filter					1
4	800446	• • Element, Boom High Pressure Filter					1
5	801925	• Elbow, Temperature Sensor					1
6	W-105568	• Sensor, 55 C Temperature					1
7	801814	• Channel, Oil Cooler Bracket					1
8	801868	• Assembly, Hydraulic Oil Cooler					1
9	801935	• Assembly, Hydraulic Tank (Aft Mar 2000) (See Group 30, Figure 10 for DET)					1
10	802281	• Assembly, Oil Cooler Manifold (See Group 30, Figure 11 for DET)					1
11	801487-006	• Assembly, Tube					1
12	W-104847	• Assembly, Swing Tube Manifold					1
13	W-105573	• Assembly, Swing Tube Circuit Solenoid Valve					1
14	W-105581	• • Pilot, Solenoid Valve					1
15	W-105576	• • • Coil, Swing Tube Circuit Solenoid Valve					2
16	W-105572	• Cartridge, Solenoid Valve					1
17	W-105605	• • Coil					1
18	W-105579	• Valve, HP Limiter					1
19	W-103616	• Accumulator					1
20	71460	• Kit, Accumulator Charge (Optional Item) (See Group 80, Figure 02 for REF)					1
21	73171	• Bracket, Accumulator					A/R
22	W-105582	• Valve, Proportional Pilot					1
23	W-105606	• • Coil					1
24	W-105581	• Assembly, Pump Control Solenoid Valve					1
25	W-105576	• • Coil, Pump Control Solenoid Valve					2
26	W-104846	• Assembly, Pump Control Manifold					1
27	W-105570	• Cartridge, Relief Valve					1
28	W-105577	• Cartridge, Check Valve					1
29	W-105578	• Valve, Ball					1
30	W-104691	• Plug					4
31	801496	• Assembly, Suction Filter					1
32	801498	• • Element, Suction Filter					1
33		• • Gauge, Suction Filter					1
34	801871-003	• Plug					3
35	801026	• Gauge, Level / Temperature 10 Inch					1
36	80264-016	• Flange, Split					1
37	801508	• Adapter, 45					1
38	801526	• Adapter, STR					1

DASH (-) ITEM NOT ILLUSTRATED

## TANK INSTALLATION (AFTER MARCH 2000)

**AFTER MARCH 2000**

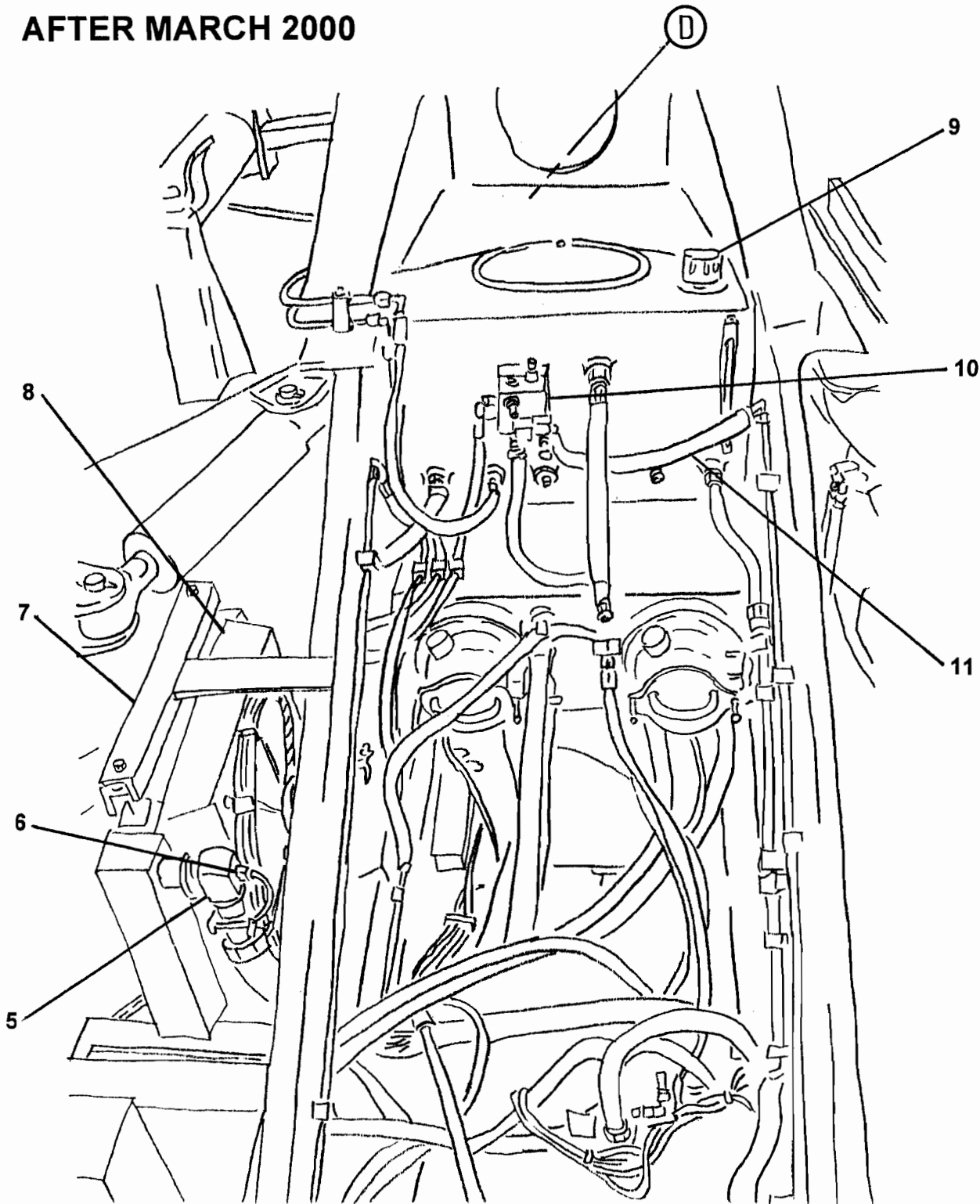

**(B)**

ITEM NO.	REED'S PARTS NO.	DESCRIPTION					QTY
		1	2	3	4	5	
-1	30-02	Installation, Tank (Aft Mar 2000) (See Group 10, Figure 01 for NHA)					Ref
2	30-04	• Group, Water System (Aft Mar 2000) (See Group 30, Figure 04 for DET)					1
3	W-105526	• Assembly, Boom High Pressure Filter					1
4	800446	• • Element, Boom High Pressure Filter					1
5	801925	• Elbow, Temperature Sensor					1
6	W-105568	• Sensor, 55 C Temperature					1
7	801814	• Channel, Oil Cooler Bracket					1
8	801868	• Assembly, Hydraulic Oil Cooler					1
9	801935	• Assembly, Hydraulic Tank (Aft Mar 2000) (See Group 30, Figure 10 for DET)					1
10	802281	• Assembly, Oil Cooler Manifold (See Group 30, Figure 11 for DET)					1
11	801487-006	• Assembly, Tube					1
12	W-104847	• Assembly, Swing Tube Manifold					1
13	W-105573	• Assembly, Swing Tube Circuit Solenoid Valve					1
14	W-105581	• • Pilot, Solenoid Valve					1
15	W-105576	• • • Coil, Swing Tube Circuit Solenoid Valve					2
16	W-105572	• Cartridge, Solenoid Valve					1
17	W-105605	• • Coil					1
18	W-105579	• Valve, HP Limiter					1
19	W-103616	• Accumulator					1
20	71460	• Kit, Accumulator Charge (Optional Item) (See Group 80, Figure 02 for REF)					1
21	73171	• Bracket, Accumulator					A/R
22	W-105582	• Valve, Proportional Pilot					1
23	W-105606	• • Coil					1
24	W-105581	• Assembly, Pump Control Solenoid Valve					1
25	W-105576	• • Coil, Pump Control Solenoid Valve					2
26	W-104846	• Assembly, Pump Control Manifold					1
27	W-105570	• Cartridge, Relief Valve					1
28	W-105577	• Cartridge, Check Valve					1
29	W-105578	• Valve, Ball					1
30	W-104691	• Plug					4
31	801496	• Assembly, Suction Filter					1
32	801498	• • Element, Suction Filter					1
33		• • Gauge, Suction Filter					1
34	801871-003	• Plug					3
35	801026	• Gauge, 10 Inch level					1
36	80264-016	• Flange, Split					1
37	801508	• Adapter, 45					1
38	801526	• Adapter, STR					1

DASH (-) ITEM NOT ILLUSTRATED

## TANK INSTALLATION (AFTER MARCH 2000)

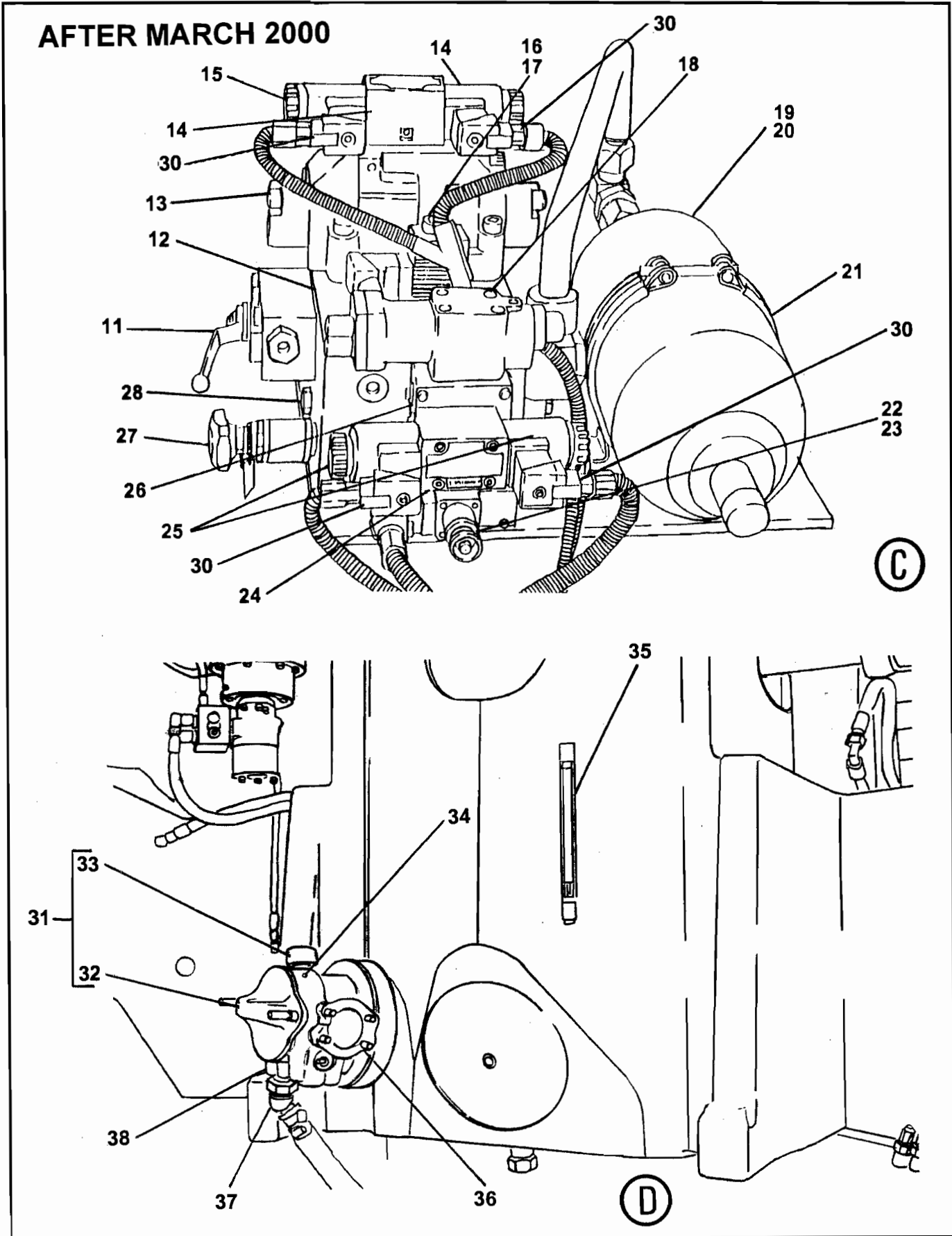



ITEM NO.	REED'S PARTS NO.	DESCRIPTION					QTY
		1	2	3	4	5	
-1	30-02	Installation, Tank (Aft Mar 2000) (See Group 10, Figure 01 for NHA)					Ref
2	30-04	• Group, Water System (Aft Mar 2000) (See Group 30, Figure 04 for DET)					1
3	W-105526	• Assembly, Boom High Pressure Filter					1
4	800446	• • Element, Boom High Pressure Filter					1
5	801925	• Elbow, Temperature Sensor					1
6	W-105568	• Sensor, 55 C Temperature					1
7	801814	• Channel, Oil Cooler Bracket					1
8	801868	• Assembly, Hydraulic Oil Cooler					1
9	801935	• Assembly, Hydraulic Tank (Aft Mar 2000) (See Group 30, Figure 10 for DET)					1
10	802281	• Assembly, Oil Cooler Manifold (See Group 30, Figure 11 for DET)					1
11	801487-006	• Assembly, Tube					1
12	W-104847	• Assembly, Swing Tube Manifold					1
13	W-105573	• Assembly, Swing Tube Circuit Solenoid Valve					1
14	W-105581	• • Pilot, Solenoid Valve					1
15	W-105576	• • • Coil, Swing Tube Circuit Solenoid Valve					2
16	W-105572	• Cartridge, Solenoid Valve					1
17	W-105605	• • Coil					1
18	W-105579	• Valve, HP Limiter					1
19	W-103616	• Accumulator					1
20	71460	• Kit, Accumulator Charge (Optional Item) (See Group 80, Figure 02 for REF)					1
21	73171	• Bracket, Accumulator					A/R
22	W-105582	• Valve, Proportional Pilot					1
23	W-105606	• • Coil					1
24	W-105581	• Assembly, Pump Control Solenoid Valve					1
25	W-105576	• • Coil, Pump Control Solenoid Valve					2
26	W-104846	• Assembly, Pump Control Manifold					1
27	W-105570	• Cartridge, Relief Valve					1
28	W-105577	• Cartridge, Check Valve					1
29	W-105578	• Valve, Ball					1
30	W-104691	• Plug					4
31	801496	• Assembly, Suction Filter					1
32	801498	• • Element, Suction Filter					1
33		• • Gauge, Suction Filter					1
34	801871-003	• Plug					3
35	801026	• Gauge, 10 Inch level					1
36	80264-016	• Flange, Split					1
37	801508	• Adapter, 45					1
38	801526	• Adapter, STR					1

DASH (-) ITEM NOT ILLUSTRATED



# WATER TANK ASSEMBLY (BEFORE FEBRUARY 2000)

**XT 36**  
**PARTS**  
GROUP 30  
FIGURE 03  
PAGE 01

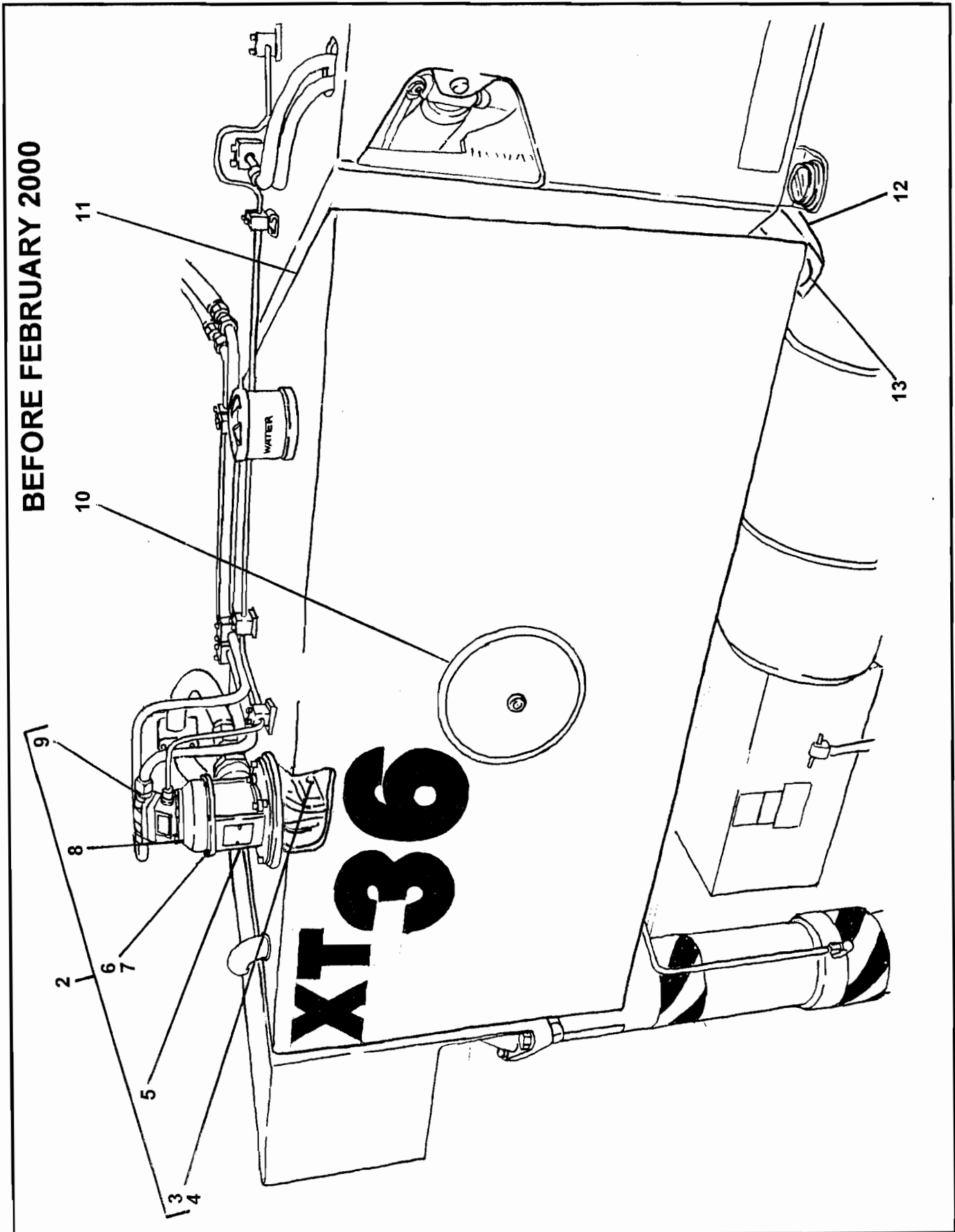



# WATER TANK ASSEMBLY (BEFORE FEBRUARY 2000)

**XT 36**  
**PARTS**  
GROUP 30  
FIGURE 03  
PAGE 02

## BEFORE FEBRUARY 2000

ITEM NO.	REED'S PARTS NO.	DESCRIPTION					QTY
		1	2	3	4	5	
-1	800748	Assembly, Water Tank (Bef Feb 2000) (See Group 30, Figure 01 for NHA)					Ref
2	W-104176	• Assembly, Water Pump And Drive					1
3	B-321502	• • Coupling					1
4	W-103646	• • Screw, M6					2
5	W-100122	• • Assembly, Wash Water Pump (Bef Feb 2000) (See Group 30, Figure 05 for DET)					1
6	W-101838	• • Screw, M6					8
7	W-103674	• • Washer, Spring					8
8	B-321505	• • Flange					1
9	W-100121	• • Assembly, Water Pump Motor (Bef Feb 2000) (See Group 30, Figure 07 for DET)					1
10	801023	• Kit, End Cover					1
11	801124	• Weldment, Water Tank					1
12	801135	• Bracket, Tank					4
13	W-104496	• Buffer, Rubber					4

DASH (-) ITEM NOT ILLUSTRATED

# REED

## WATER SYSTEM GROUP (AFTER MARCH 2000)

**XT 36**  
**PARTS**  
GROUP 30  
FIGURE 04  
PAGE 01

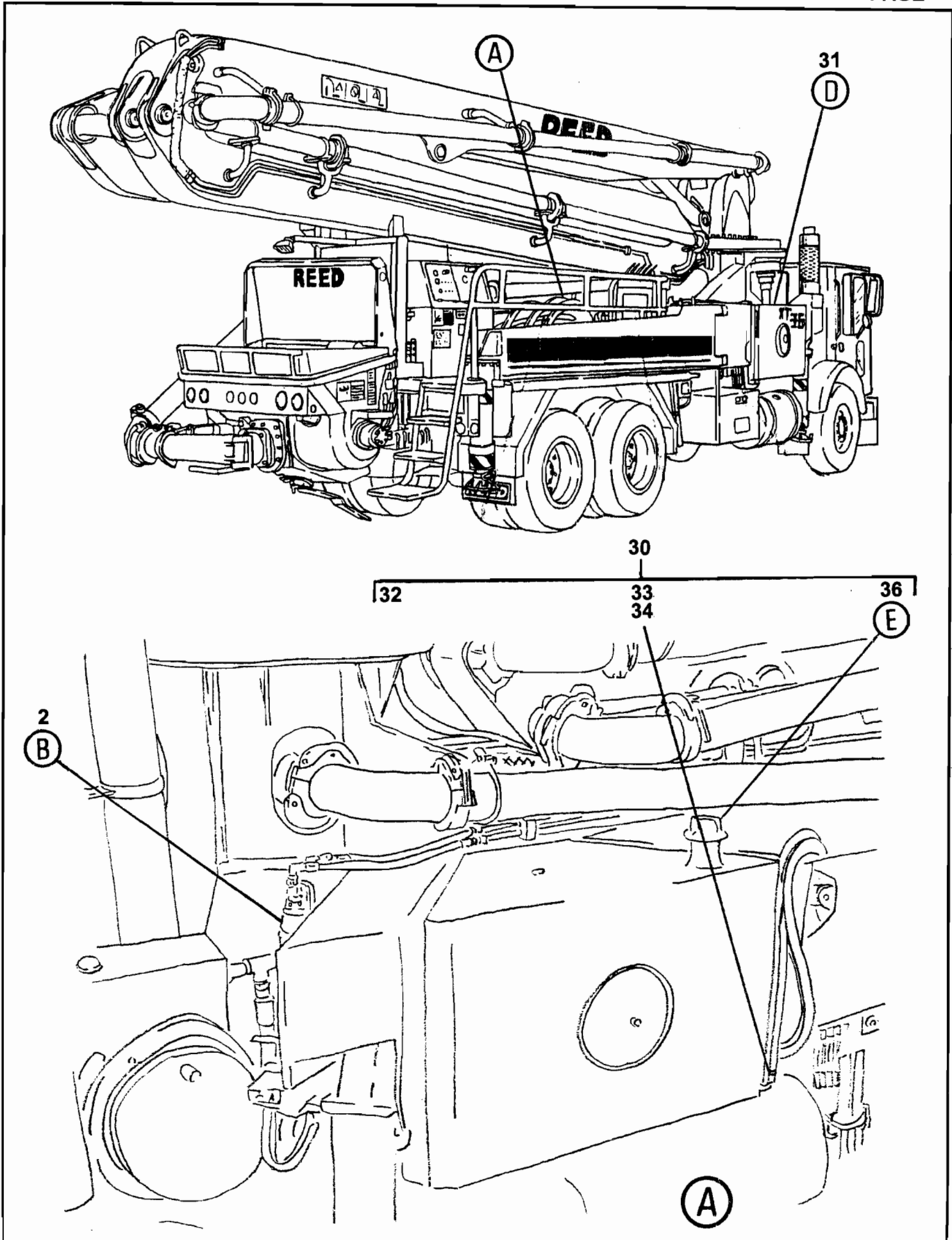

ITEM NO.	REED'S PARTS NO.	DESCRIPTION					QTY
		1	2	3	4	5	
-1	30-04	Group, Water System (Aft Mar 2000) (See Group 30, Figure 02 for NHA)					Ref
2	802247	• Kit, Water Pump Retro-Fit					1
3	801740	•• Plate, Water Pump					1
4	85663-008	•• Assembly, Hose					1
5	801896-004	•• Fitting, STR					1
6	801487-012	•• Assembly, Hose					1
7	801896-003	•• Fitting, STR					1
8	78128	•• Valve, Relief					1
9		•• Tee					1
10	802295	•• Adapter, Water pump Flange					1
11	802294	•• Adapter, Water pump Flange					1
12	801899-003	•• Union, Swivel					2
13	801877-004	•• Union, Tube					2
14	801888-004	•• Elbow, Swivel					2
15	801486-001	•• Assembly, Hose					2
16	802325	•• Plate, Water Pump Cover					1
17	B-323030	•• Assembly, Water Pump And Drive					1
18	W-101126	••• Assembly, Wash Water Pump (Aft Mar 2000) (See Group 30, Figure 06 for DET)					1
19	B-323019	••• Coupling					1
20	B-323016	••• Flange					1
21	W-105929	••• Screw, M8					4
22	W-100235	••• Washer, Spring					8
23	W-105922	••• Assembly, Water Pump Motor (Aft Mar 2000) (See Group 30, Figure 08 for DET)					1
24	W-102916	••• Coupling, Splined					1
25	W-102915	••• Support, Belt Pulley					1
26	W-105930	••• Screw, M8					4
27	W-103673	••• Bolt, M6 Alien					1
28	W-105931	••• Ring, Locking					1
29	B-323021	••• Washer					1
30	801959	• Assembly, LH Water Tank					1
31	801960	• Assembly, RH Water Tank					1
32	801023	•• Kit, Endcover					1
33	801978	•• Tubing, Clear 28 Inch					1
34	802289	•• Clamp, Hose					2
-35	W-104496	•• Buffer, Rubber					4
36	801708	•• Weldment, Water tank					1
37		••• Screw, Socket head Cap					2
38	801682	••• Weldment, Water Tank cap					1
39	30214	••• Chain, 12 inch					1

DASH (-) ITEM NOT ILLUSTRATED

## WATER SYSTEM GROUP (AFTER MARCH 2000)

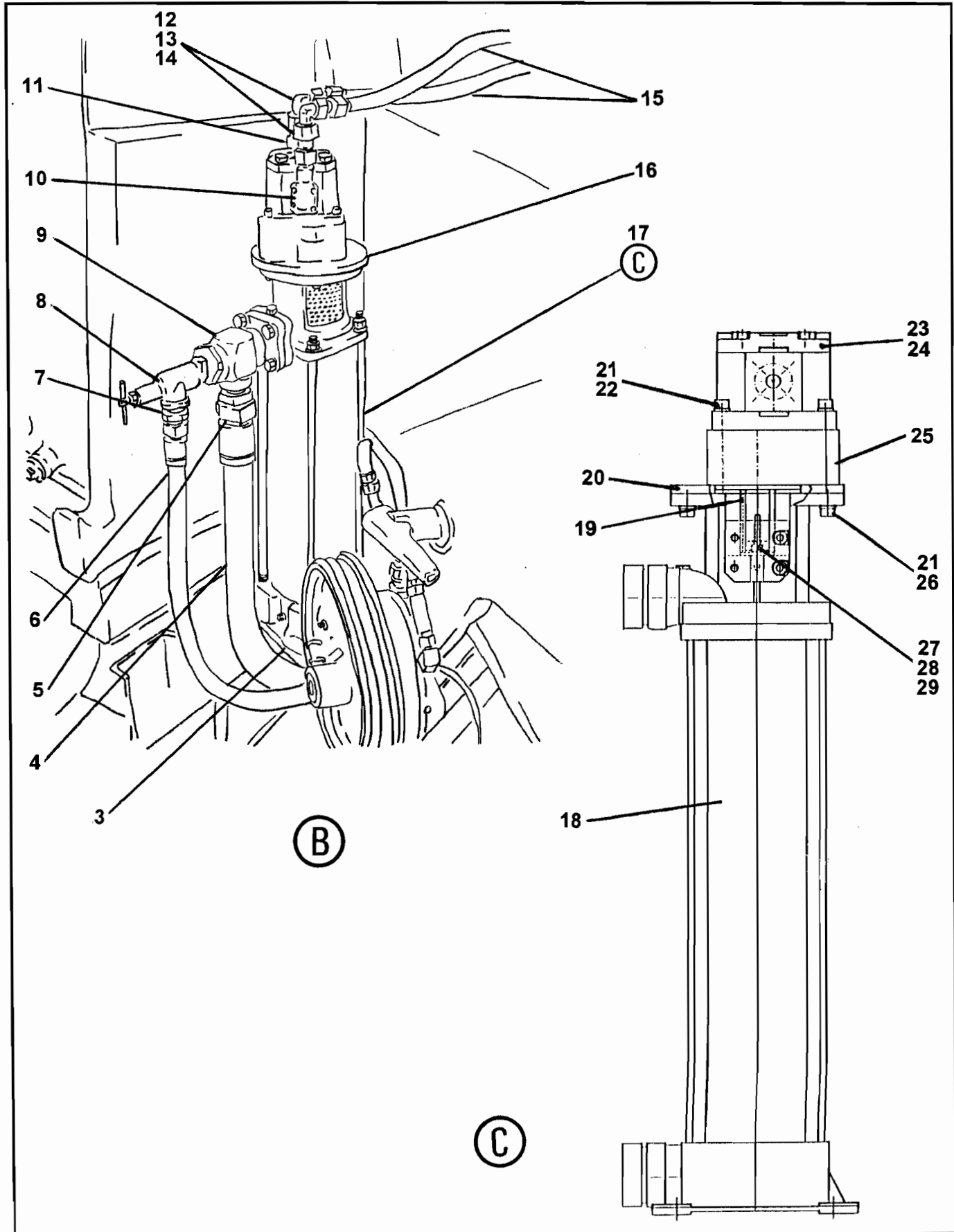



## WATER SYSTEM GROUP (AFTER MARCH 2000)

**XT 36**  
**PARTS**  
GROUP 30  
FIGURE 04  
PAGE 04

ITEM NO.	REED'S PARTS NO.	DESCRIPTION					QTY
		1	2	3	4	5	
-1	30-04	Group, Water System (Aft Mar 2000) (See Group 30, Figure 02 for NHA)					Ref
2	802247	• Kit, Water Pump Retro-Fit					1
3	801740	• • Plate, Water Pump					1
4	85663-008	• • Assembly, Hose					1
5	801896-004	• • Fitting, STR					1
6	801487-012	• • Assembly, Hose					1
7	801896-003	• • Fitting, STR					1
8	78128	• • Valve, Relief					1
9		• • Tee					1
10	802295	• • Adapter, Water pump Flange					1
11	802294	• • Adapter, Water pump Flange					1
12	801899-003	• • Union, Swivel					2
13	801877-004	• • Union, Tube					2
14	801888-004	• • Elbow, Swivel					2
15	801486-001	• • Assembly, Hose					2
16	802325	• • Plate, Water Pump Cover					1
17	B-323030	• • Assembly, Water Pump And Drive					1
18	W-101126	• • • Assembly, Wash Water Pump (Aft Mar 2000) (See Group 30, Figure 06 for DET)					1
19	B-323019	• • • Coupling					1
20	B-323016	• • • Flange					1
21	W-105929	• • • Screw, M8					4
22	W-100235	• • • Washer, Spring					8
23	W-105922	• • • Assembly, Water Pump Motor (Aft Mar 2000) (See Group 30, Figure 08 for DET)					1
24	W-102916	• • • Coupling, Splined					1
25	W-102915	• • • Support, Belt Pulley					1
26	W-105930	• • • Screw, M8					4
27	W-103673	• • • Bolt, M6 Alien					1
28	W-105931	• • • Ring, Locking					1
29	B-323021	• • • Washer					1
30	801959	• Assembly, LH Water Tank					1
31	801960	• Assembly, RH Water Tank					1
32	801023	• • Kit, Endcover					1
33	801978	• • Tubing, Clear 28 Inch					1
34	802289	• • Clamp, Hose					2
-35	W-104496	• • Buffer, Rubber					4
36	801708	• • Weldment, Water tank					1
37		• • • Screw, Socket head Cap					2
38	801682	• • • Weldment, Water Tank cap					1
39	30214	• • • Chain, 12 inch					1

DASH (-) ITEM NOT ILLUSTRATED



# WATER SYSTEM GROUP (AFTER MARCH 2000)

**XT 36**  
**PARTS**  
GROUP 30  
FIGURE 04  
PAGE 05

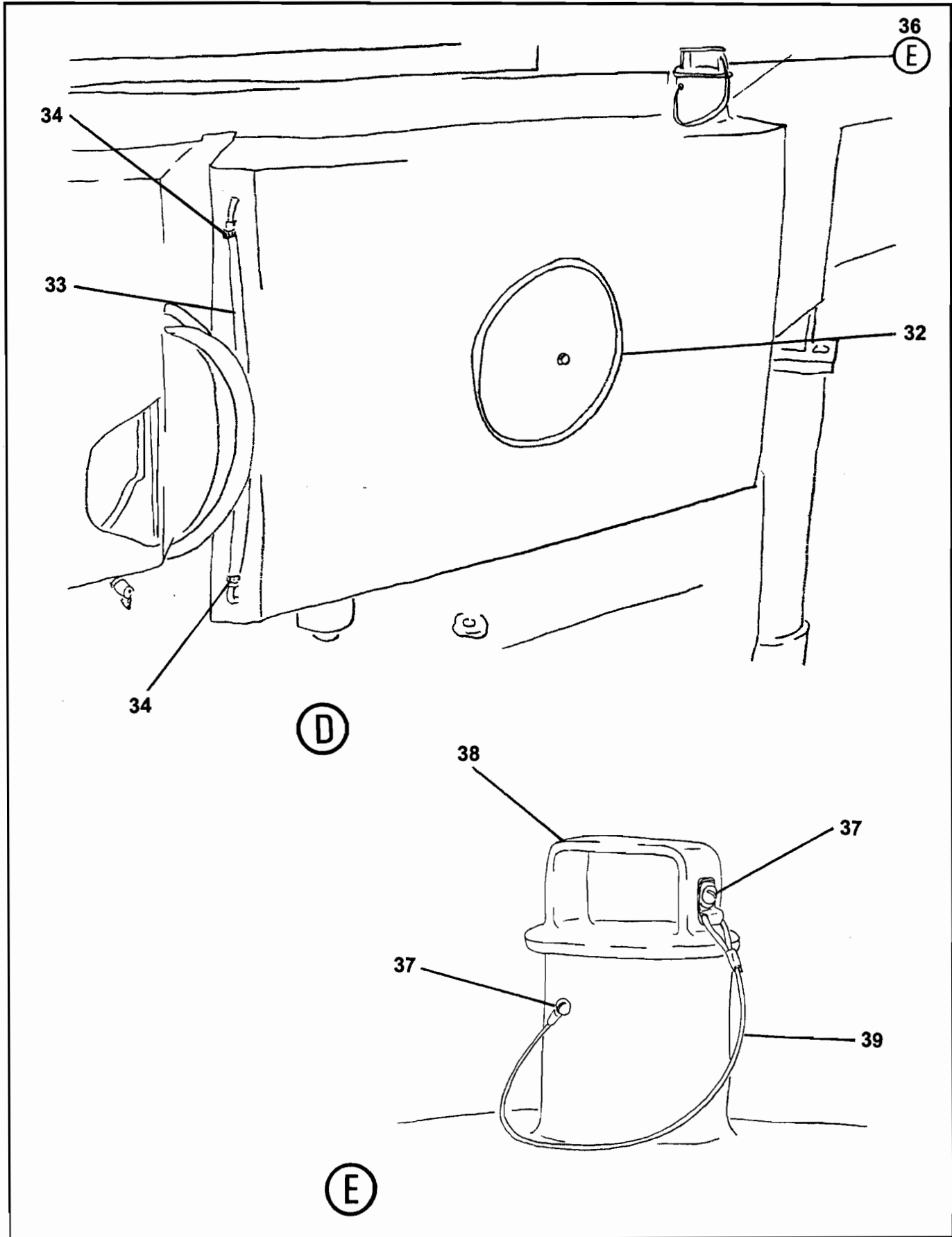





# WATER SYSTEM GROUP (AFTER MARCH 2000)

**XT 36**  
**PARTS**  
GROUP 30  
FIGURE 04  
PAGE 06

ITEM NO.	REED'S PARTS NO.	DESCRIPTION					QTY
		1	2	3	4	5	
-1	30-04	Group, Water System (Aft Mar 2000) (See Group 30, Figure 02 for NHA)					Ref
2	802247	• Kit, Water Pump Retro-Fit					1
3	801740	•• Plate, Water Pump					1
4	85663-008	•• Assembly, Hose					1
5	801896-004	•• Fitting, STR					1
6	801487-012	•• Assembly, Hose					1
7	801896-003	•• Fitting, STR					1
8	78128	•• Valve, Relief					1
9		•• Tee					1
10	802295	•• Adapter, Water pump Flange					1
11	802294	•• Adapter, Water pump Flange					1
12	801899-003	•• Union, Swivel					2
13	801877-004	•• Union, Tube					2
14	801888-004	•• Elbow, Swivel					2
15	801486-001	•• Assembly, Hose					2
16	802325	•• Plate, Water Pump Cover					1
17	B-323030	•• Assembly, Water Pump And Drive					1
18	W-101126	••• Assembly, Wash Water Pump (Aft Mar 2000) (See Group 30, Figure 06 for DET)					1
19	B-323019	••• Coupling					1
20	B-323016	••• Flange					1
21	W-105929	••• Screw, M8					4
22	W-100235	••• Washer, Spring					8
23	W-105922	••• Assembly, Water Pump Motor (Aft Mar 2000) (See Group 30, Figure 08 for DET)					1
24	W-102916	••• Coupling, Splined					1
25	W-102915	••• Support, Belt Pulley					1
26	W-105930	••• Screw, M8					4
27	W-103673	••• Bolt, M6 Alien					1
28	W-105931	••• Ring, Locking					1
29	B-323021	••• Washer					1
30	801959	• Assembly, LH Water Tank					1
31	801960	• Assembly, RH Water Tank					1
32	801023	•• Kit, Endcover					1
33	801978	•• Tubing, Clear 28 Inch					1
34	802289	•• Clamp, Hose					2
-35	W-104496	•• Buffer, Rubber					4
36	801708	•• Weldment, Water tank					1
37		••• Screw, Socket head Cap					2
38	801682	••• Weldment, Water Tank cap					1
39	30214	••• Chain, 12 inch					1

DASH (-) ITEM NOT ILLUSTRATED



# WASH WATER PUMP ASSEMBLY (BEFORE FEBRUARY 2000)

**XT 36**  
**PARTS**  
GROUP 30  
FIGURE 05  
PAGE 01

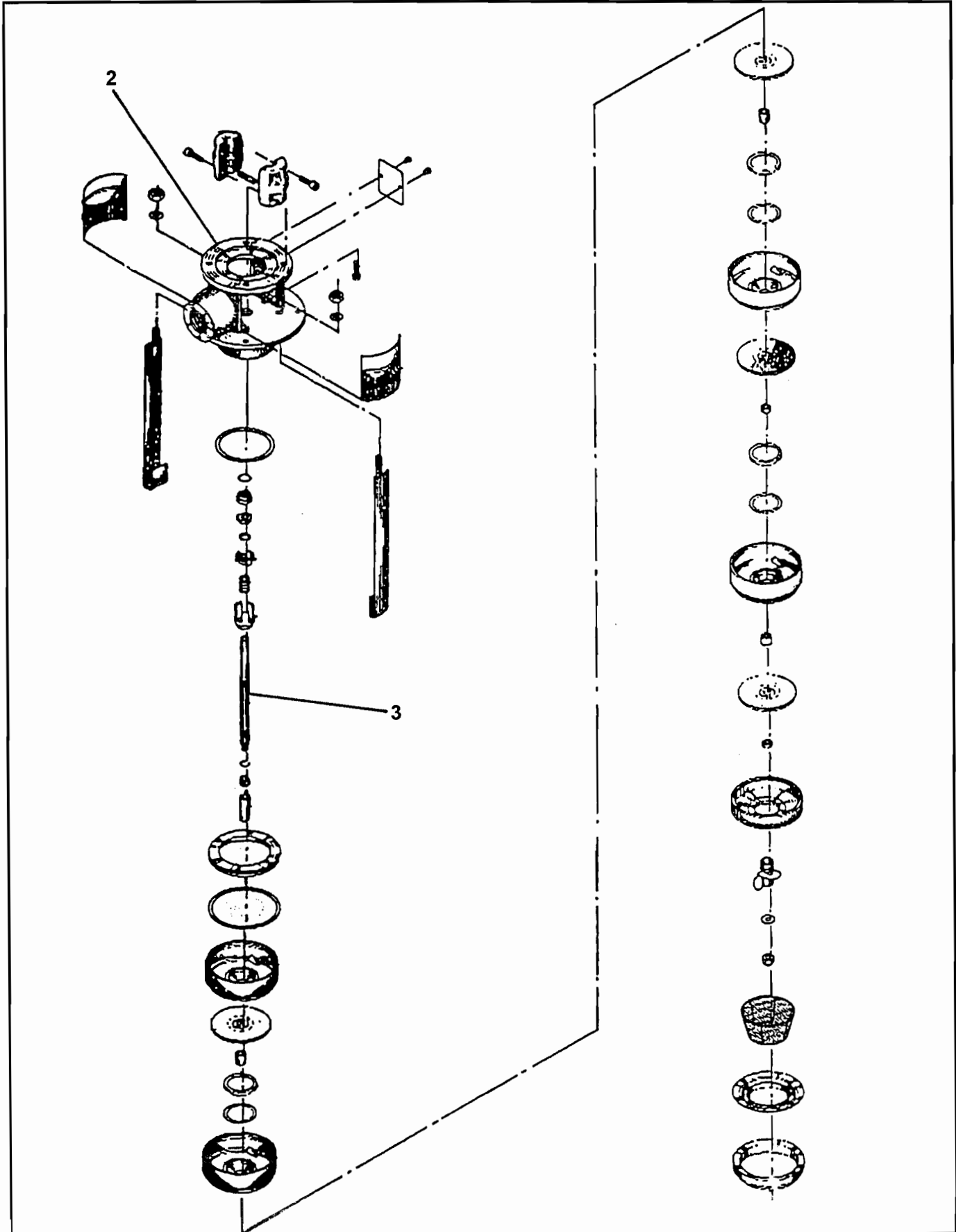



**WASH WATER PUMP ASSEMBLY  
(BEFORE FEBRUARY 2000)**

**XT 36**  
**PARTS**  
GROUP 30  
FIGURE 05  
PAGE 02

**BEFORE FEBRUARY 2000**

ITEM NO.	REED'S PARTS NO.	DESCRIPTION					QTY
		1	2	3	4	5	
-1	W-100122	Assembly, Wash Water Pump (Bef Feb 2000) (See Group 30, Figure 03 for NHA)					Ref
2	W-105221	• Housing, Pump					1
3	W-105222	• Shaft, Pump					1

DASH (-) ITEM NOT ILLUSTRATED



**WASH WATER PUMP ASSEMBLY  
(AFTER MARCH 2000)**

**XT 36**  
**PARTS**  
GROUP 30  
FIGURE 06  
PAGE 01

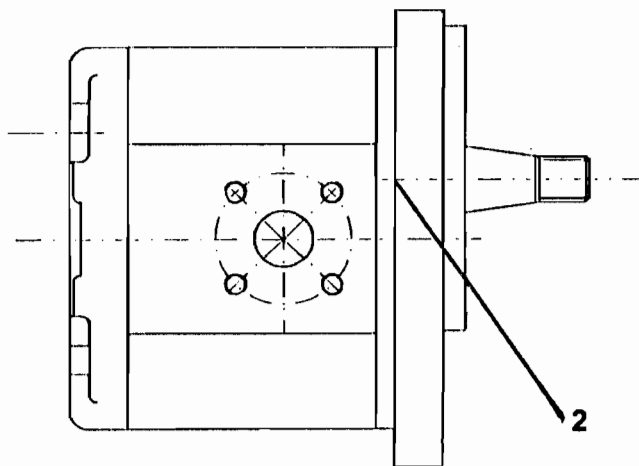



**WASH WATER PUMP ASSEMBLY  
(AFTER MARCH 2000)**

**XT 36**  
**PARTS**  
GROUP 30  
FIGURE 06  
PAGE 02

**AFTER MARCH 2000**

ITEM NO.	REED'S PARTS NO.	DESCRIPTION					QTY
		1	2	3	4	5	
-1	W-105922	Assembly, Wash Water Pump (Aft Mar 2000) (See Group 30, Figure 04 for NHA)					Ref
2	W-106044	• Kit, Seal					1

DASH (-) ITEM NOT ILLUSTRATED



**WATER PUMP MOTOR ASSEMBLY  
(BEFORE FEBRUARY 2000)**

**XT 36  
PARTS  
GROUP 30  
FIGURE 07  
PAGE 01**

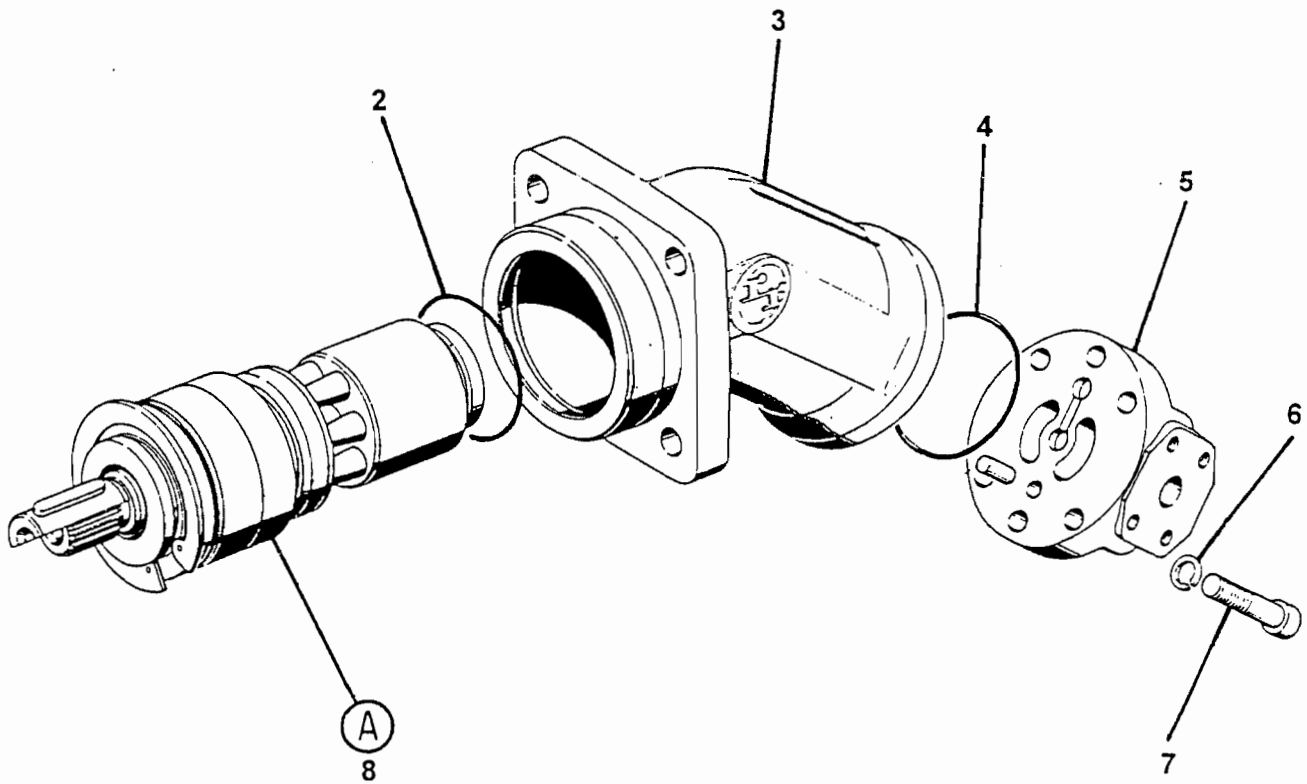

**BEFORE FEBRUARY 2000**

**BEFORE FEBRUARY 2000**

ITEM NO.	REED'S PARTS NO.	DESCRIPTION					QTY
		1	2	3	4	5	
-1	W-100121	Assembly, Water Pump Motor (Bef Feb 2000) (See Group 30, Figure 03 for NHA)					Ref
2		• O-Ring					1
3		• Housing					1
4		• O-Ring					1
5		• Plate, Port					1
6		• Washer, Lock					4
7		• Screw, M6					4
8		• Sub-Assembly, Rotary					1
9		•• Ring Retaining					1
10		•• Cover					1
11		•• Ring, Shaft Seal					1
12		•• Ring Retaining					1
13		•• Bearing, Tapered Roller					1
14		•• Shim					2
15		•• Shim					2
16		•• Shim					2
17		•• Bearing, Angular Contact Ball					2
18		•• Key, Shaft					1
19		•• Shaft, Drive					1
20		•• Disc					1
21		•• Plate, Retaining					1
22		•• Rivet					7
23		•• Pin, Center					1
24		•• Cup, Spring					4
25		•• Collar, Spring					1
26		•• Shim					1
27		•• Piston					7
28		•• Ring, Steel Sealing					7
29		•• Cylinder					1
30		•• Plate, Control					1
31		• Pin					1

DASH (-) ITEM NOT ILLUSTRATED



# WATER PUMP MOTOR ASSEMBLY (BEFORE FEBRUARY 2000)

**XT 36**  
**PARTS**  
GROUP 30  
FIGURE 07  
PAGE 03

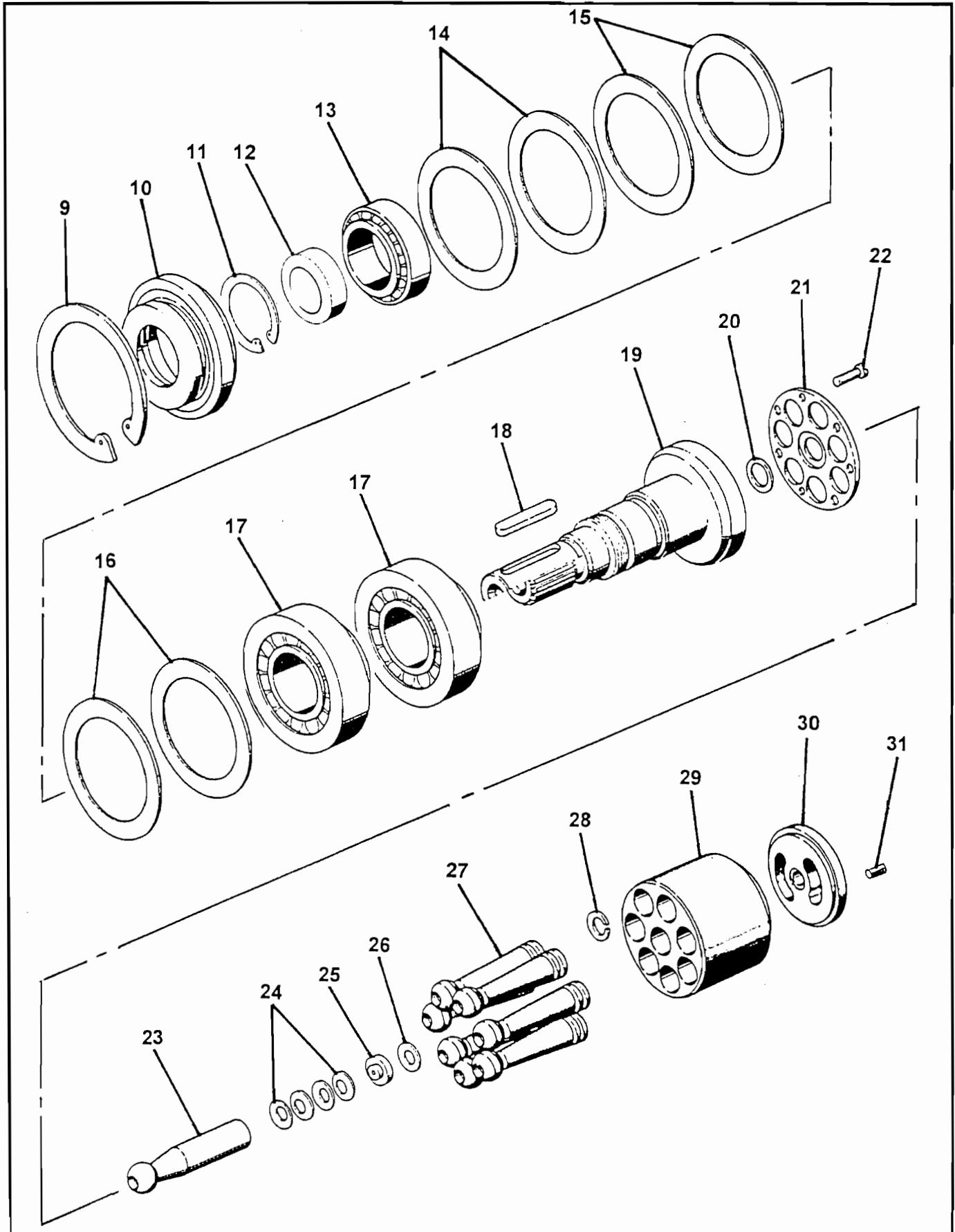





# WATER PUMP MOTOR ASSEMBLY (BEFORE FEBRUARY 2000)

**XT 36**  
**PARTS**  
GROUP 30  
FIGURE 07  
PAGE 04

ITEM NO.	REED'S PARTS NO.	DESCRIPTION	QTY
-1	W-100121	Assembly, Water Pump Motor (Bef Feb 2000) (See Group 30, Figure 02 for NHA)	Ref
2		• O-Ring	1
3		• Housing	1
4		• O-Ring	1
5		• Plate, Port	1
6		• Washer, Lock	4
7		• Screw, M6	4
8		• Sub-Assembly, Rotary	1
9		• • Ring Retaining	1
10		• • Cover	1
11		• • Ring, Shaft Seal	1
12		• • Ring Retaining	1
13		• • Bearing, Tapered Roller	1
14		• • Shim	2
15		• • Shim	2
16		• • Shim	2
17		• • Bearing, Angular Contact Ball	2
18		• • Key, Shaft	1
19		• • Shaft, Drive	1
20		• • Disc	1
21		• • Plate, Retaining	1
22		• • Rivet	7
23		• • Pin, Center	1
24		• • Cup, Spring	4
25		• • Collar, Spring	1
26		• • Shim	1
27		• • Piston	7
28		• • Ring, Steel Sealing	7
29		• • Cylinder	1
30		• • Plate, Control	1
31		• • Pin	1

DASH (-) ITEM NOT ILLUSTRATED



**WATER PUMP MOTOR ASSEMBLY  
(AFTER MARCH 2000)**

**XT 36**  
**PARTS**  
GROUP 30  
FIGURE 08  
PAGE 01

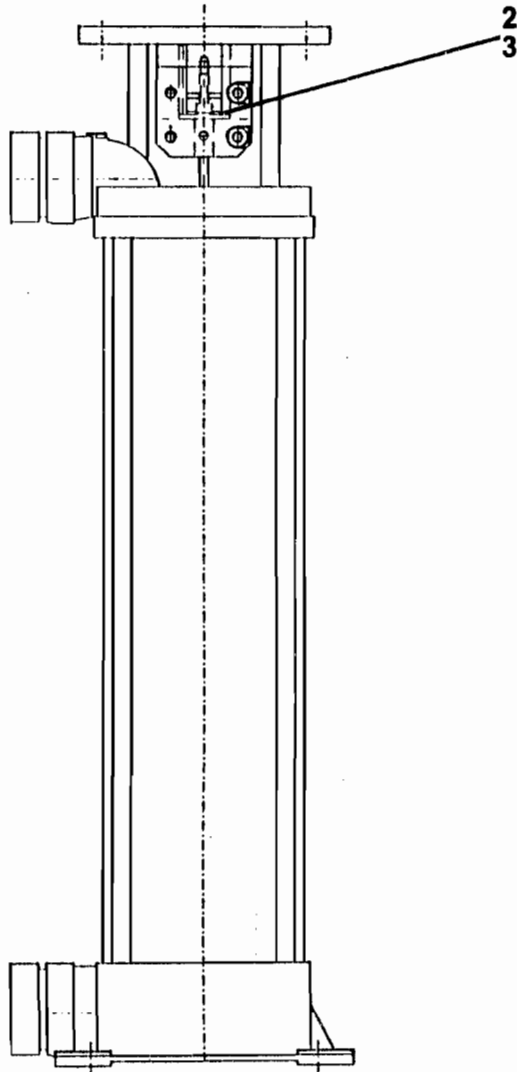



**WATER PUMP MOTOR ASSEMBLY  
(AFTER MARCH 2000)**

**XT 36  
PARTS  
GROUP 30  
FIGURE 08  
PAGE 02**

<b>ITEM NO.</b>	<b>REED'S PARTS NO.</b>	<b>DESCRIPTION</b>	<b>QTY</b>
-1	W-101126	Assembly, Water Pump Motor (Aft Mar 2000) (See Group 30, Figure 04 for NHA)	Ref
2	W-105988	• Coupling	1
3	W-106043	• Kit, Seal	1

DASH (-) ITEM NOT ILLUSTRATED



**HYDRAULIC TANK ASSEMBLY  
(BEFORE FEBRUARY 2000)**

**XT 36**  
**PARTS**  
GROUP 30  
FIGURE 09  
PAGE 01

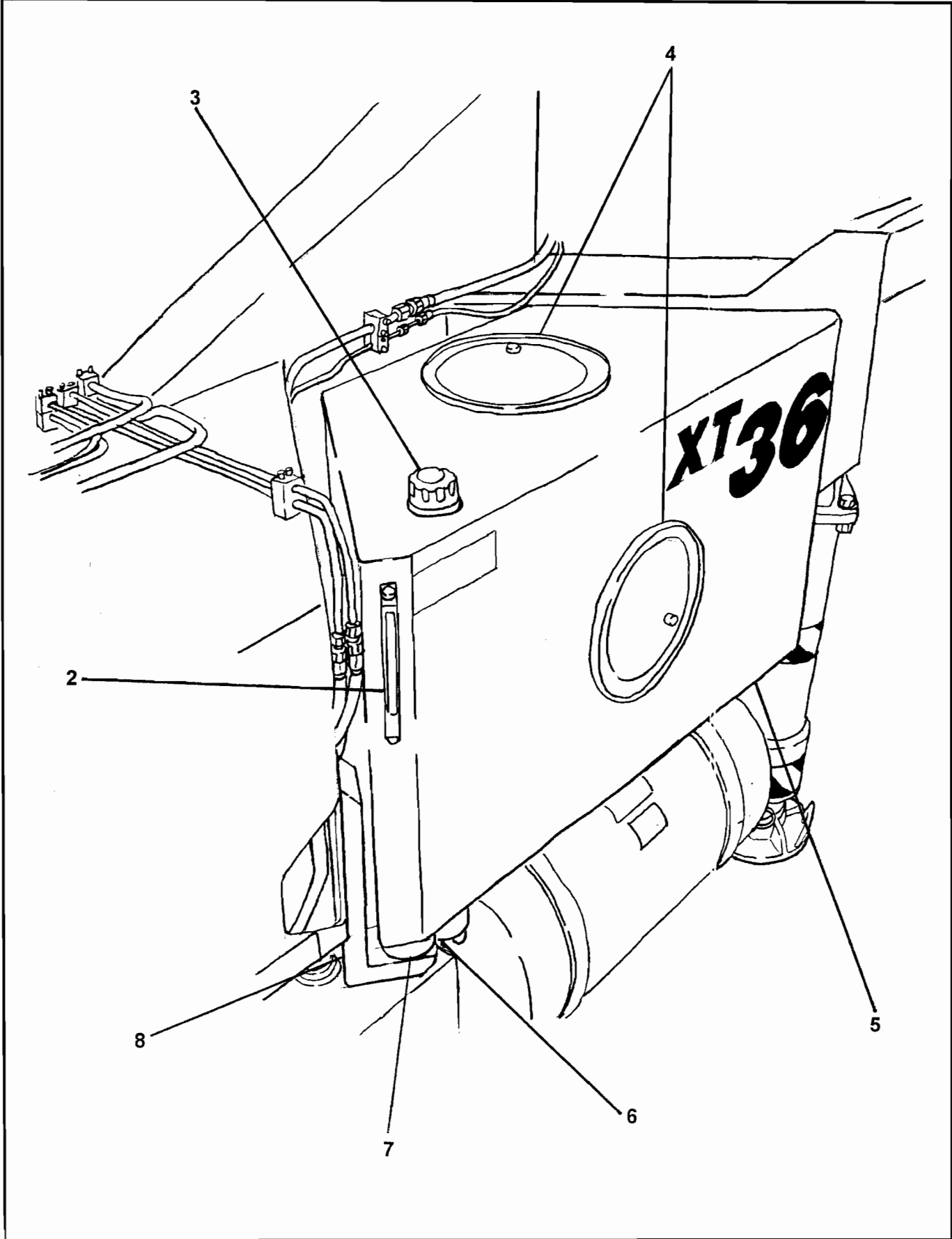



**HYDRAULIC TANK ASSEMBLY  
(BEFORE FEBRUARY 2000)**

**XT 36  
PARTS  
GROUP 30  
FIGURE 09  
PAGE 02**

ITEM NO.	REED'S PARTS NO.	DESCRIPTION					QTY
		1	2	3	4	5	
-1	800664	Assembly, Hydraulic Tank (Bef Feb 2000) (See Group 30, Figure 01 for NHA)					Ref
2	801026	• Gauge, Level / Temperature					1
3	74508	• Breather, Filler					1
4	801023	• Kit, End Cover					A/R
5	801009	• Weldment, Hydraulic Tank					1
6	801025	• Cock, Drain					1
7	W-104496	• Buffer, Rubber					4
8	801135	• Bracket, Tank					4

DASH (-) ITEM NOT ILLUSTRATED



# HYDRAULIC TANK ASSEMBLY (AFTER MARCH 2000)

**XT 36**  
**PARTS**  
GROUP 30  
FIGURE 10  
PAGE 01

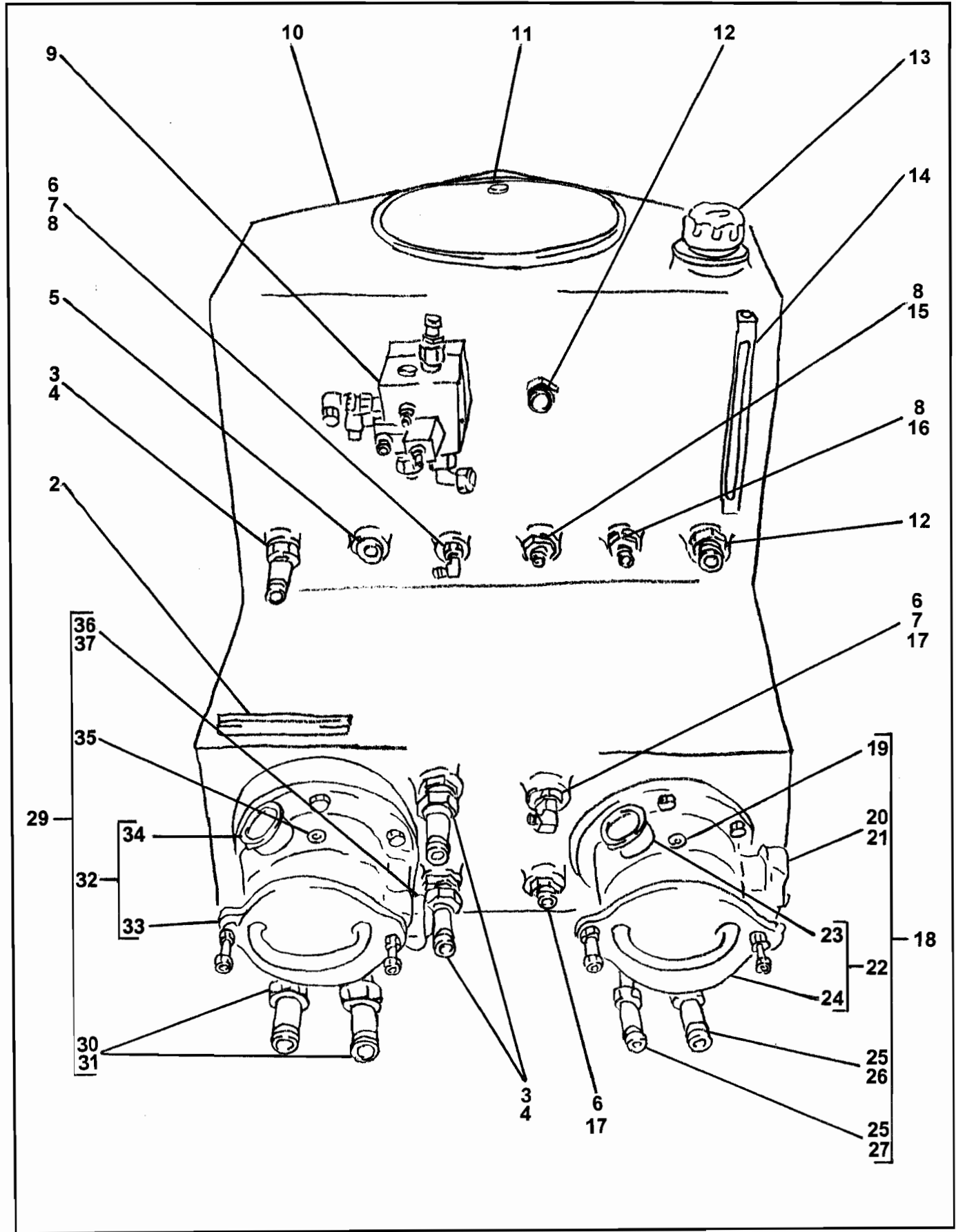

ITEM NO.	REED'S PARTS NO.	DESCRIPTION					QTY
		1	2	3	4	5	
-1	801935	Assembly, Hydraulic Tank (Aft Mar2000) (See Group 30, Figure 02 for NHA)					Ref
2	801171-007	• C-Rail, 6.5 Inch					1
3	W-105170	• Adapter, STR					3
4		• Fitting, STR					3
5	801871-006	• Plug					1
6	801888-003	• Elbow, Swivel					2
7	801873-006	• Adapter, STR					2
8	801895-001	• Reducer					3
9	802281	• Assembly, Oil Cooler Manifold (See Group 30, Figure 11 for DET)					1
10	801700	• Weldment, Hydraulic Tank					1
11	801023	• • Kit, End Cover					1
12	801872-008	• Adapter, STR					2
13	74508	• Breather, Filler					1
14	801026	• Gauge, Level / Temperature 10 Inch					1
15	801873-008	• Adapter, STR					1
16	801873-010	• Adapter, STR					1
17	801895-001	• Reducer					2
18	802370	• Assembly, RH Suction Filter					1
19	801871-003	• • Plug					3
20	801937	• • Plug, Flange					1
21	86264-016	• • Flange, Split					1
22	801496	• • Assembly, Suction Filter					1
23		• • • Gauge, Suction Filter					1
24	801498	• • • Element, Suction Filter					1
25	801526	• • Adapter, STR					2
26	801506	• • Adapter, 90					1
27	801509	• • Adapter, 90					1
-28	W-104496	• Buffer, Rubber					4
29	802371	• Assembly, LH Suction Filter					1
30	801526	• • Adapter, STR					2
31	801506	• • Adapter, 90					2
32	801496	• • Assembly, Suction Filter					1
33	801498	• • • Element, Suction Filter					1
34		• • • Gauge, Suction Filter					1
35	801871-003	• • Plug					3
36	801937	• • Plug, Flange					1
37	86264-016	• • Flange, Split					1

DASH (-) ITEM NOT ILLUSTRATED



# OIL COOLER MANIFOLD ASSEMBLY (AFTER MARCH 2000)

XT 36  
PARTS  
GROUP 30  
FIGURE 11  
PAGE 01

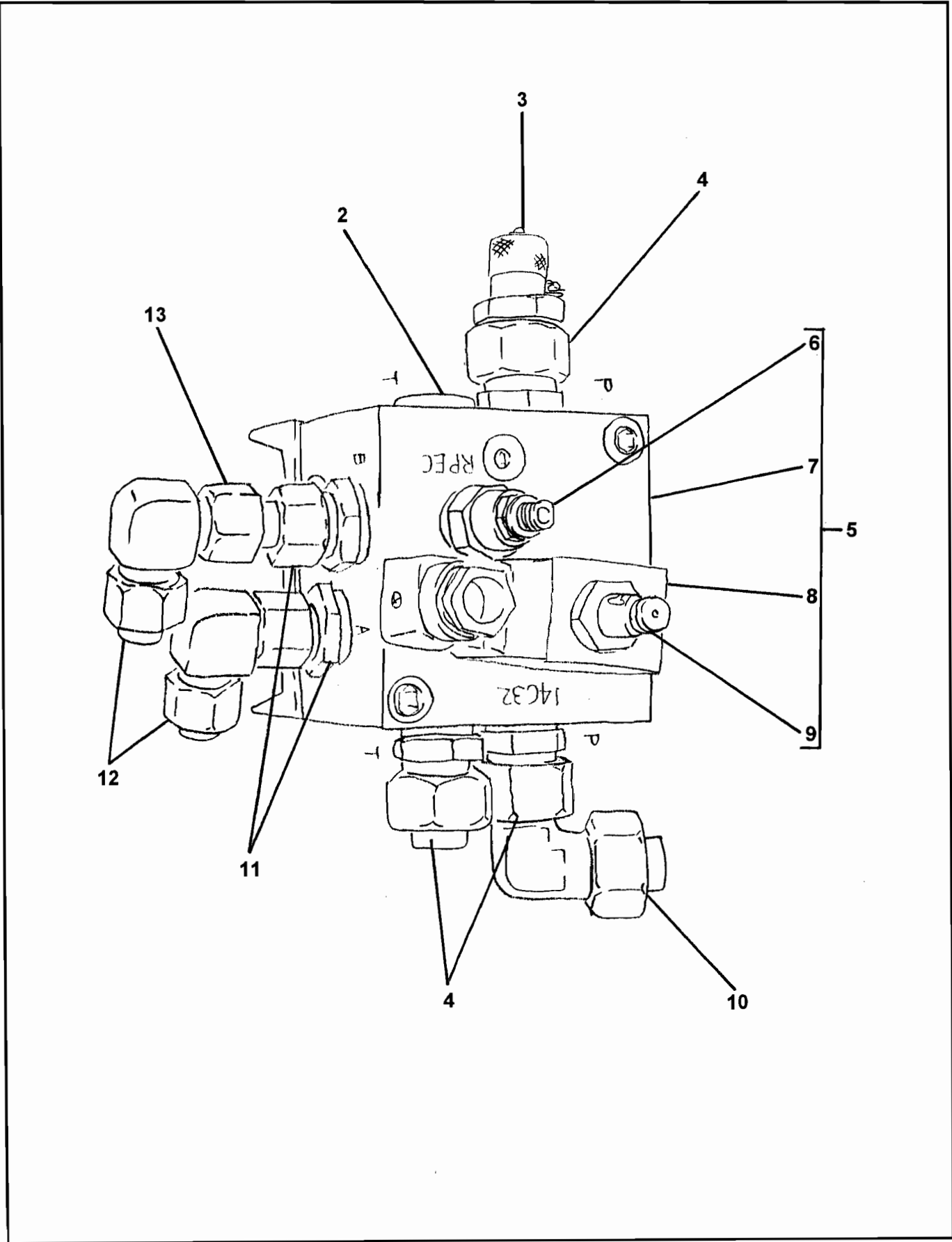





**OIL COOLER MANIFOLD ASSEMBLY  
(AFTER MARCH 2000)**

**XT 36**  
**PARTS**  
GROUP 30  
FIGURE 11  
PAGE 02

ITEM NO.	REED'S PARTS NO.	DESCRIPTION					QTY
		1	2	3	4	5	
-1	802281	Assembly, Oil Cooler Manifold (Aft Mar2000) (See Group 30, Figure 02 and Figure 10 for NHA)					Ref
2	801871-004	• Plug					1
3	W-104831	• Fitting, L15 Gauge					1
4	801873-010	• Adapter, STR					3
5	801629	• Manifold, Oil Cooler					1
6	801837	• • Cartridge, Relief					1
7		• • Block, Manifold					1
8	801839	• • Coil, Manifold					1
9	801838	• • Cartridge, Manifold Solenoid					1
10	801888-005	• Elbow, Swivel					1
11	801873-006	• Adapter, STR					2
12	801888-002	• Elbow, Swivel					2
13	801899-002	• Union, Swivel					1

DASH (-) ITEM NOT ILLUSTRATED

**REED**

**TRUCK MOUNTED CONCRETE PUMP XT36  
ILLUSTRATED PARTS MANUAL**

**XT 36**  
**PARTS**  
GROUP 30  
FIGURE 12  
PAGE 01

THIS PAGE INTENTIONALLY LEFT BLANK.

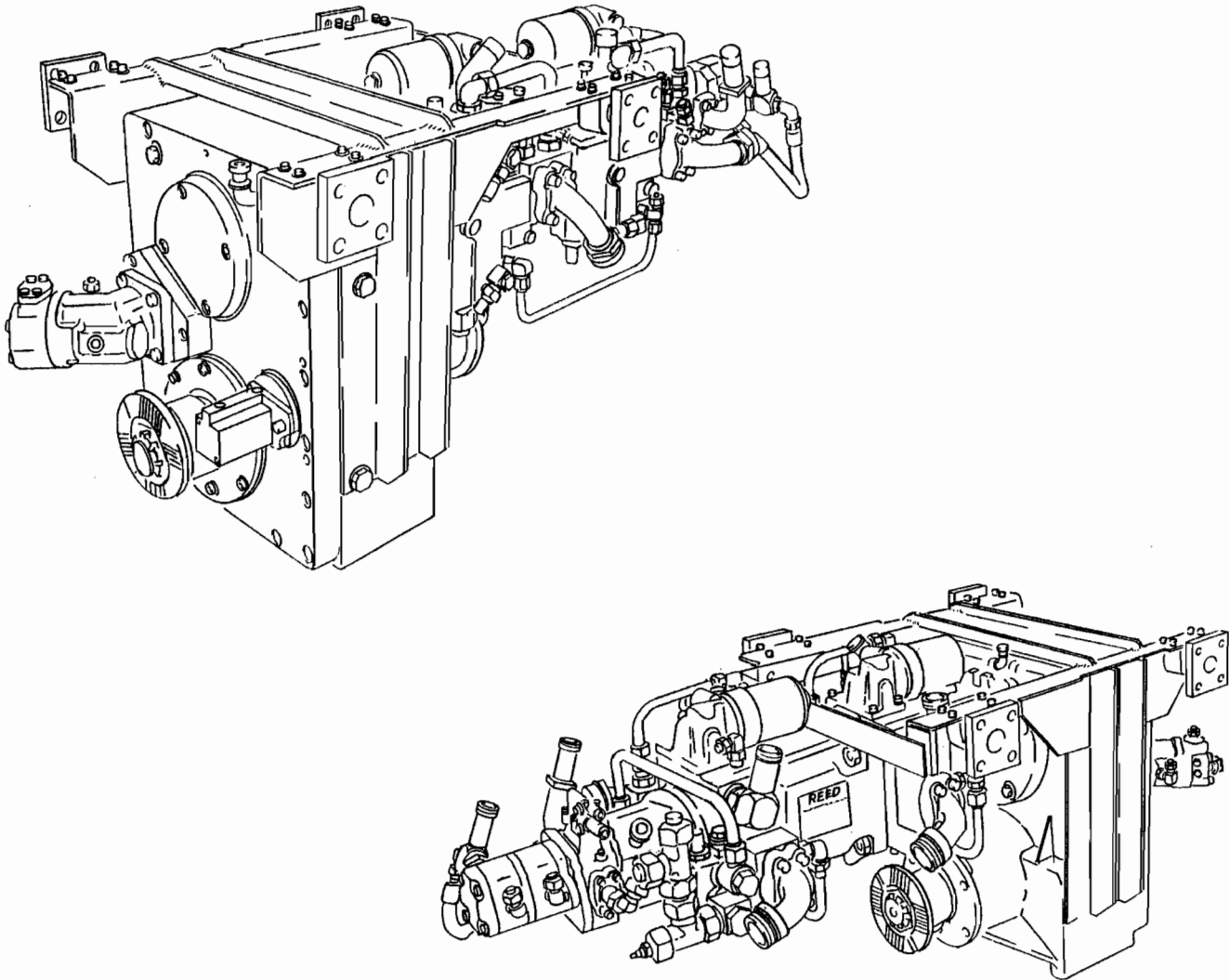

**SHOWN MODEL: AFTER MARCH 2001**

**REED TRUCK MOUNTED CONCRETE BOOM PUMP MODEL XT 36 ILLUSTRATED PARTS MANUAL GROUP 40 POWER TRAIN INSTALLATION CONTAINS THE FOLLOWING FIGURES:**

- |                  |   |
|------------------|---|
| <b>FIGURE 00</b> | <b>TABLE OF CONTENTS</b>                              |
| <b>FIGURE 01</b> | <b>POWER TRAIN INSTALLATION (BEF JUL 1999)</b>        |
| <b>FIGURE 02</b> | <b>POWER TRAIN INSTALLATION (AUG 1999 ~ MAR 2000)</b> |
| <b>FIGURE 03</b> | <b>POWER TRAIN INSTALLATION (APR 2000 ~ FEB 2001)</b> |
| <b>FIGURE 04</b> | <b>POWER TRAIN INSTALLATION (AFT MAR 2001)</b>        |
| <b>FIGURE 05</b> | <b>GEAR PUMP ASSEMBLY</b>                             |
| <b>FIGURE 06</b> | <b>PTO GEARBOX ASSEMBLY</b>                           |

**BEFORE JULY 1999**

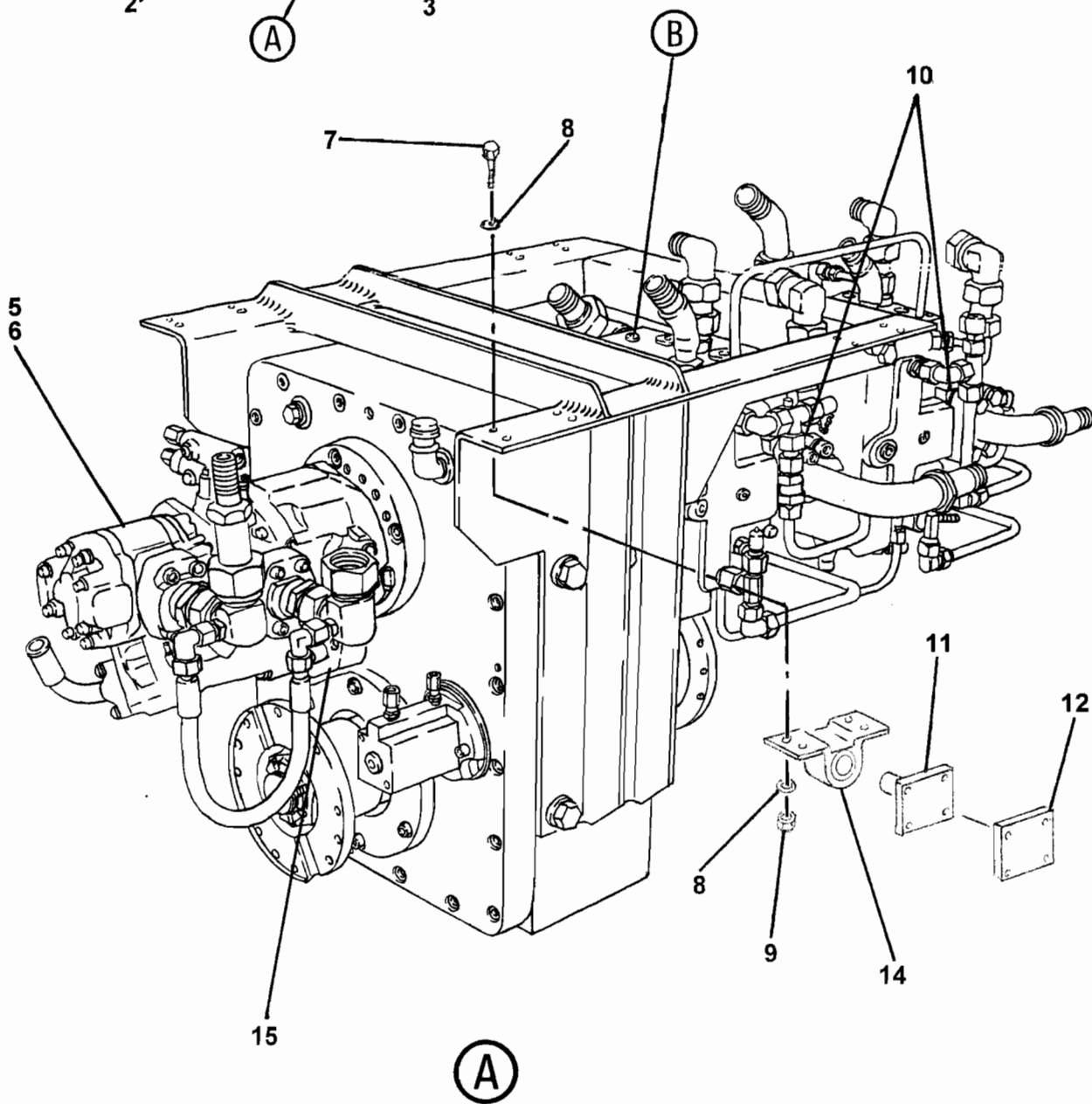
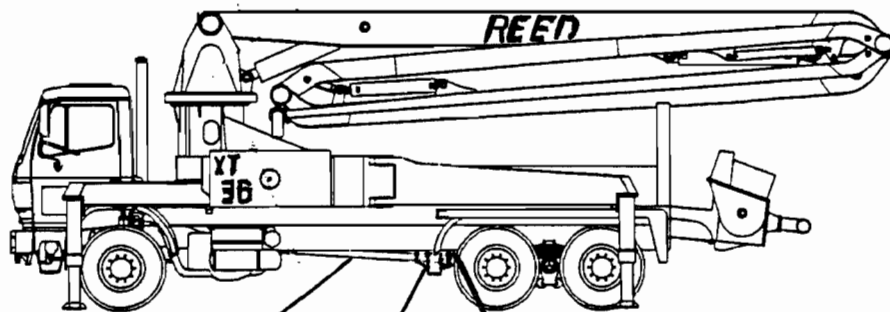

**BEFORE JULY 1999**

ITEM NO.	REED'S PARTS NO.	DESCRIPTION					QTY
		1	2	3	4	5	
-1	40-01	Installation, Power Train (Before Jul 1999) (See Group 10, Figure 01 for NHA)					Ref
2	801043	• Shaft, Front Drive					1
3	801044	• Shaft, Rear Drive					1
4	800606	• Group, <b>XT 36</b> Gearbox					1
5	801022	• Assembly, Gear Pump					1
6	800061	• • O-Ring					1
7		• • Bolt, Hex					16
8		• • Washer					32
9		• • Nut, Lock					16
10	801057	• • Manifold, Pump					3
11	800125	• • Axle, PTO Mount					4
12	800128	• • Plate, PTO Axle Mount					4
13	W-104870	• • Assembly, PTO Gearbox with Rexroth					1
14	W-103414	• • • Buffer, Rubber					4
15	W-104703	• • • Assembly, S-Tube Circuit Pump					1
16	W-103623	• • • Assembly, Boom Pump					1
17	W-104526	• • • Assembly, PTO Gearbox					1
18	W-105513	• • • • Switch, PTO Gearbox					1
19	W-104704	• • • Assembly, Rexroth Pump					2
20	801088	• • Brace, PTO Mount					1
21	801087	• • Mount, PTO Gearbox with Rexroth					1
22	801058	• • Manifold, Boom Pump					1
-23	800063	• • Valve, Air					1
-24	800064	• • Muffler, Air Valve					1

DASH (-) ITEM NOT ILLUSTRATED

BEFORE JULY 1999

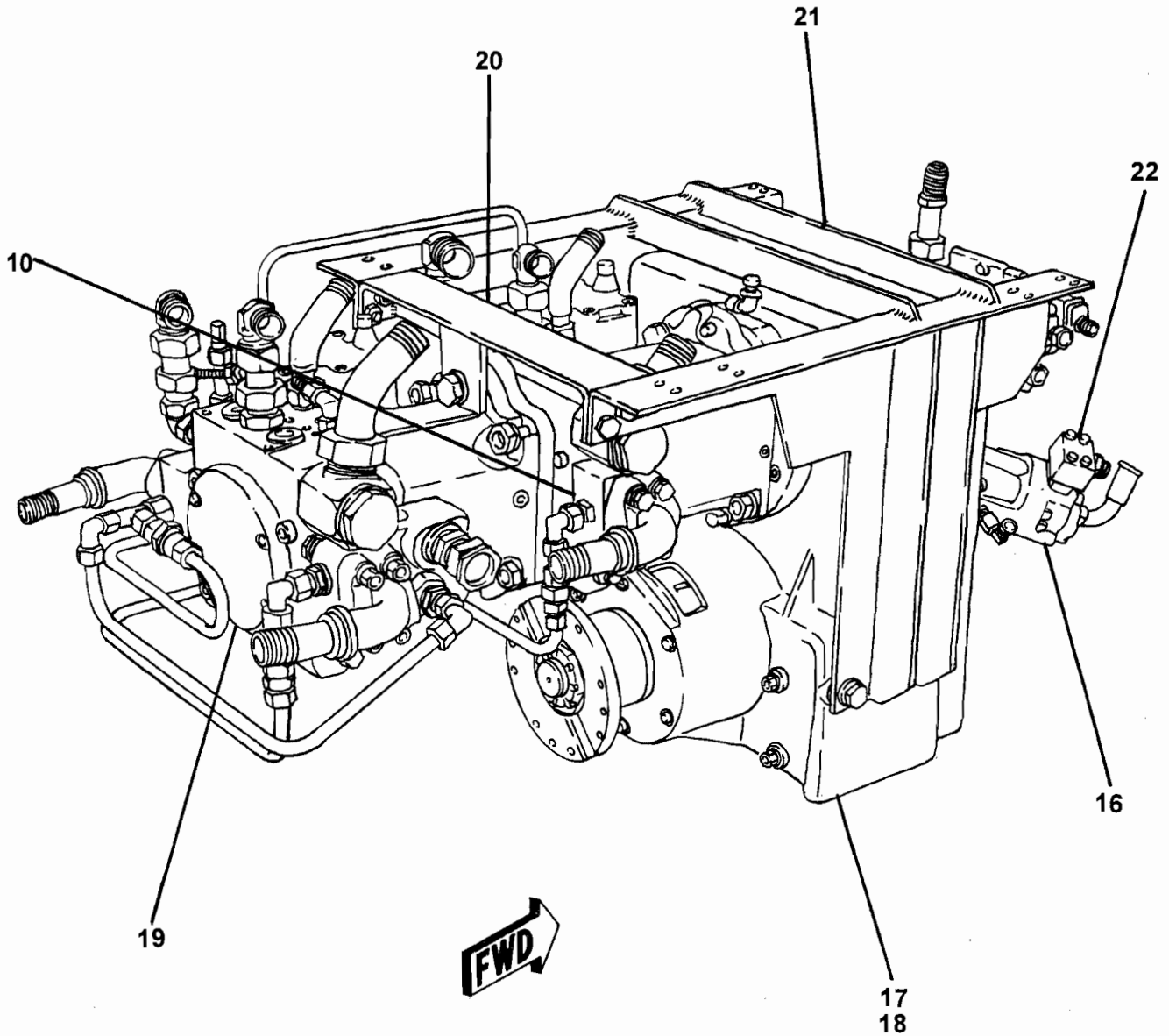

**BEFORE JULY 1999**

ITEM NO.	REED'S PARTS NO.	DESCRIPTION					QTY
		1	2	3	4	5	
-1	40-01	Installation, Power Train (Before Jul 1999) (See Group 10, Figure 01 for NHA)					Ref
2	801043	• Shaft, Front Drive					1
3	801044	• Shaft, Rear Drive					1
4	800606	• Group, <b>XT 36</b> Gearbox (Before Jul 1999)					1
5	801022	• Assembly, Gear Pump					1
6	800061	• • O-Ring					1
7		• • Bolt, Hex					16
8		• • Washer					32
9		• • Nut, Lock					16
10	801057	• • Manifold, Pump					3
11	800125	• • Axle, PTO Mount					4
12	800128	• • Plate, PTO Axle Mount					4
13	W-104870	• • Assembly, PTO Gearbox with Rexroth					1
14	W-103414	• • • Buffer, Rubber					4
15	W-104703	• • • Assembly, S-Tube Circuit Pump					1
16	W-103623	• • • Assembly, Boom Pump					1
17	W-104526	• • • Assembly, PTO Gearbox					1
18	W-105513	• • • • Switch, PTO Gearbox					1
19	W-104704	• • • Assembly, Rexroth Pump					2
20	801088	• • Brace, PTO Mount					1
21	801087	• • Mount, PTO Gearbox with Rexroth					1
22	801058	• • Manifold, Boom Pump					1
-23	800063	• • Valve, Air					1
-24	800064	• • Muffler, Air Valve					1

DASH (-) ITEM NOT ILLUSTRATED

AUGUST 1999 ~ MARCH 2000

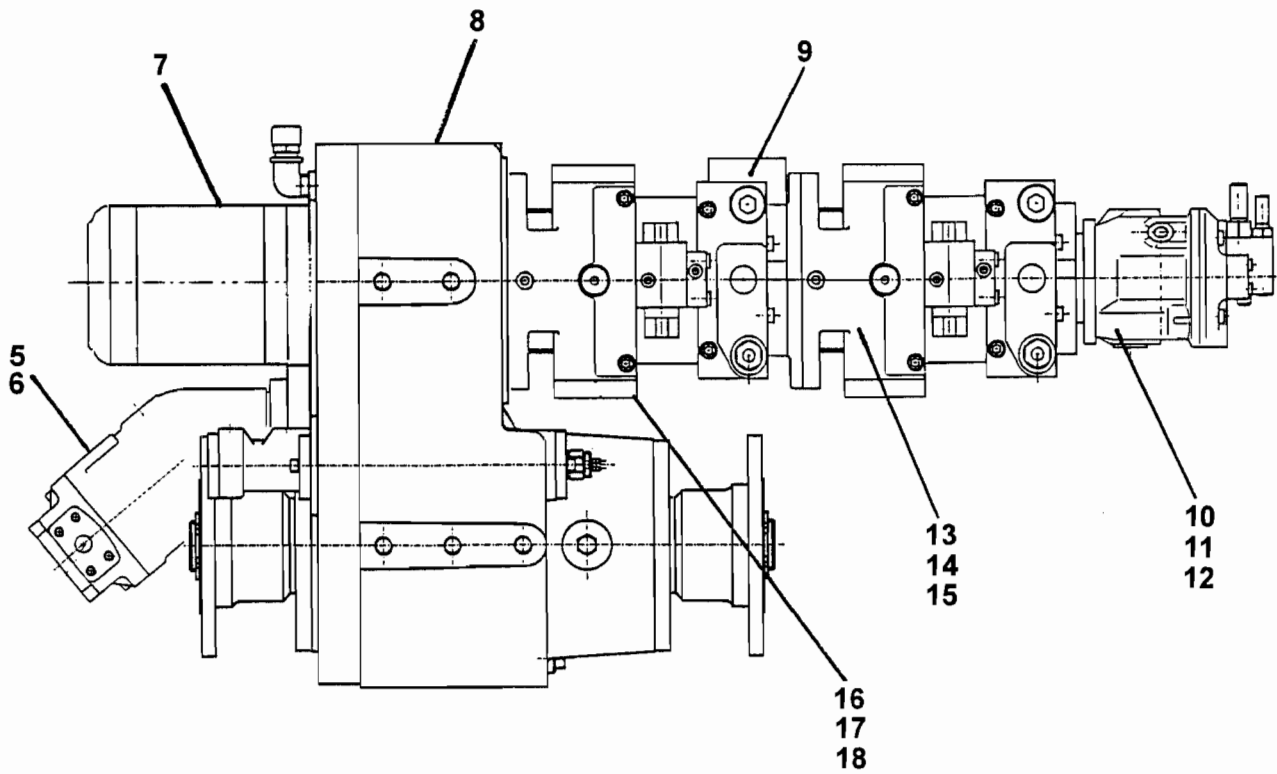
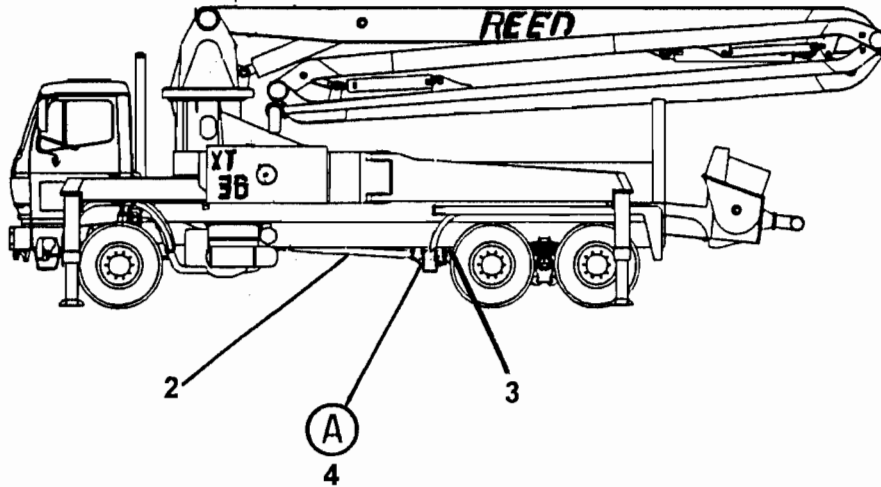

(A)



**AUGUST 1999 ~ MARCH 2000**

ITEM NO.	REED'S PARTS NO.	DESCRIPTION					QTY
		1	2	3	4	5	
-1	40-02	Installation, Power Train (Aug 1999 ~ Mar 2000) (See Group 10, Figure 01 for NHA)					Ref
2	801043	• Shaft, Front Drive					1
3	801044	• Shaft, Rear Drive					1
4	W-105340	• Group, <b>XT 36</b> Gearbox (Aug 1999 ~ Mar 2000)					1
5	W-103623	•• Assembly, Boom Pump					1
6	801058	•• Manifold, Boom Pump					1
7	801397	•• Assembly, 4/4CC Gear Pump					1
8	W-104870	•• Assembly, PTO Gearbox					1
9	W-104949	•• Valve, Flushing					1
10	W-105594	•• Assembly, A10VO28 Gear Pump					1
11	W-105789	••• Kit, A10VO28 Gear Pump Seal					1
12	W-105001	••• Seal, Shaft					1
13	W-105592	•• Assembly, A4VG125 Gear Pump					1
14	W-105787	••• Kit, A4VG125Gear Pump Seal					1
15	W-105788	••• Seal, Shaft					1
16	W-105591	•• Assembly, A4VG125 Gear Pump					1
17	W-105785	••• Kit, A4VG125Gear Pump Seal					1
18	W-105786	••• Seal, Shaft					1

DASH (-) ITEM NOT ILLUSTRATED

APRIL 2000 ~ FEBRUARY 2001

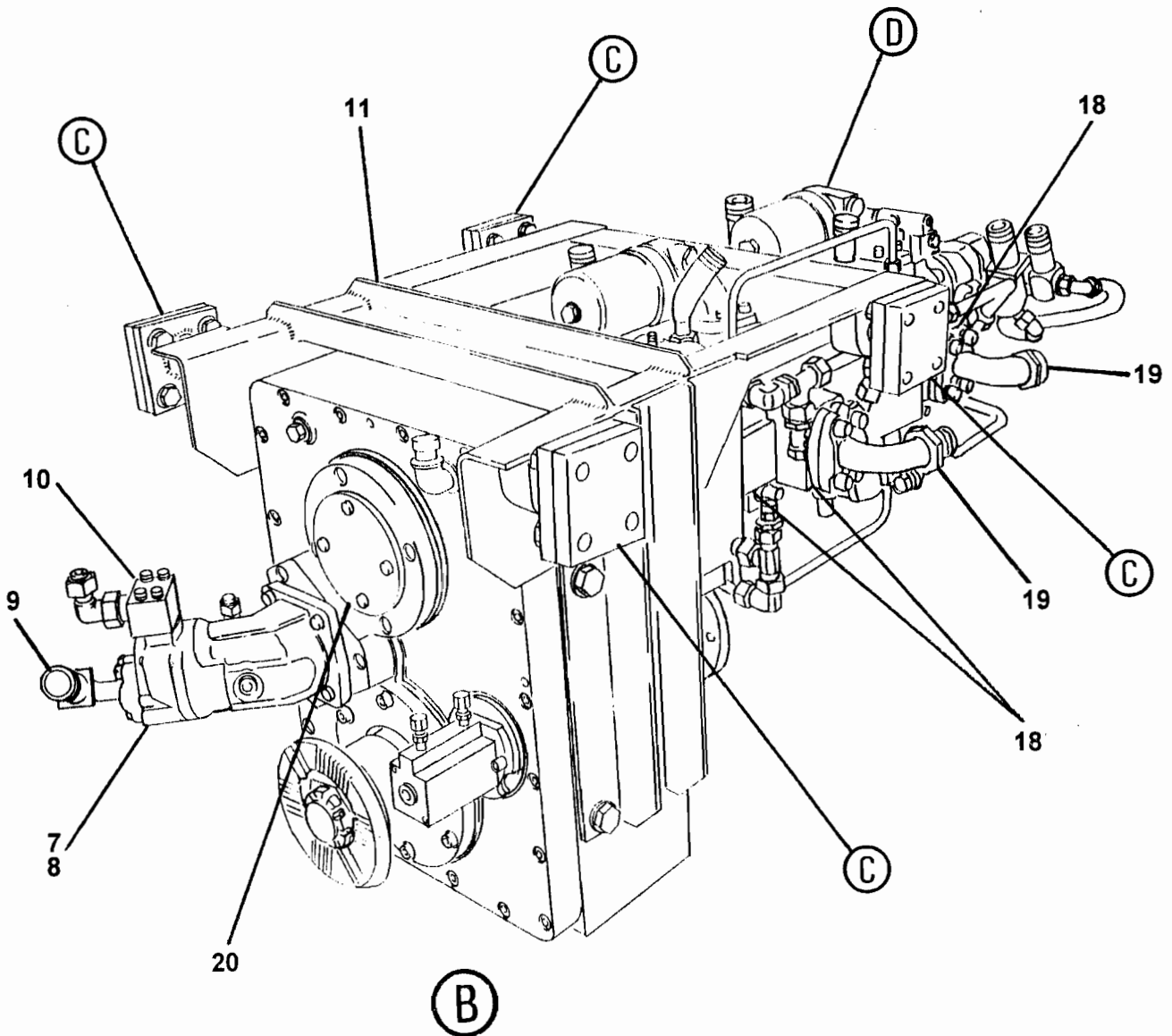
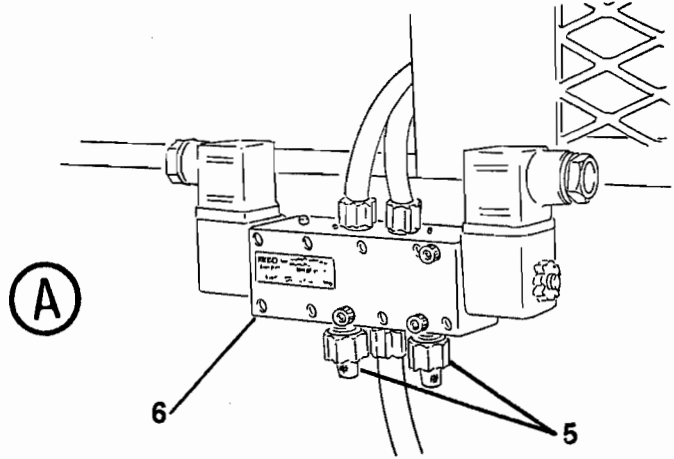
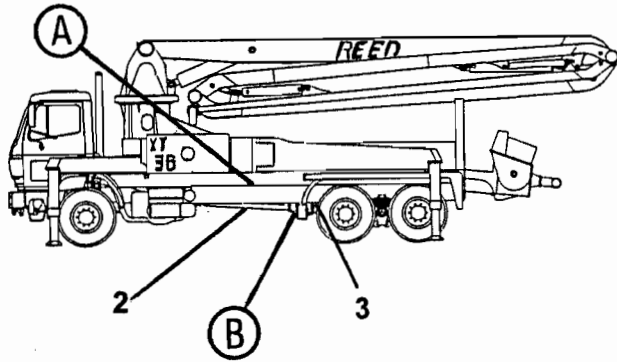

**APRIL 2000 ~ FEBRUARY 2001**

ITEM NO.	REED'S PARTS NO.	DESCRIPTION					QTY
		1	2	3	4	5	
-1	40-03	Installation, Power Train (Apr 2000 ~ Feb 2001) (See Group 10, Figure 01 for NHA)					Ref
2	801480	• Shaft, Front Drive					1
3	801481	• Shaft, Rear Drive					1
-4	800610	• Group, <b>XT 36</b> Gearbox					1
5	800064	• • Muffler, Air Valve					2
6	800063	• • Valve, Air					1
7	W-103623	• • Assembly, Boom Pump					1
8	W-105629	• • • Seal, Boom Pump Shaft					1
9	801511	• • Adapter, 90L					1
10	801058	• • Manifold, Boom Pump					1
11	801087	• • Mount, PTO Gearbox with Rexroth					1
12		• • Bolt, Hex					16
13		• • Washer					32
14		• • Nut, Lock					16
15	W-103414	• • Buffer, Rubber					4
16	800125	• • Axle, PTO Mount					4
17	800128	• • Plate, PTO Axle Mount					4
18	801778	• • Manifold, Pump					2
19	801503	• • Adapter, 90L					4
20	75861	• • Cover, Bolt Housing					1
21	801510	• • Adapter, 90L					1
22	801516	• • Adapter, STR					1
23	801684	• • Assembly, 4/4CC Gear Pump					1
24	800061	• • • O-Ring, Gear Pump					1
25	801512	• • Adapter, 90L					1
26	W-105650	• • Assembly, Gear Pump (See Group 40, Figure 05 for DET)					1
27	801506	• • Adapter, 90L					2
28	801526	• • Adapter, STR					2
29	801527	• • Adapter, STR					1
30	801057	• • Manifold, Pump					2
31	W-105539	• • Assembly, PTO Gearbox (See Group 40, Figure 06 for DET)					1
32	W-105513	• • • Switch, PTO Gearbox					1
33	801499	• • Filter, Charge Pump					2
34	801500	• • • Element, Charge Pump Filter					2
35	801088	• • Brace, PTO Mount					1
36	W-105075	• • Adapter, 90L					1

DASH (-) ITEM NOT ILLUSTRATED

APRIL 2000 ~ FEBRUARY 2001

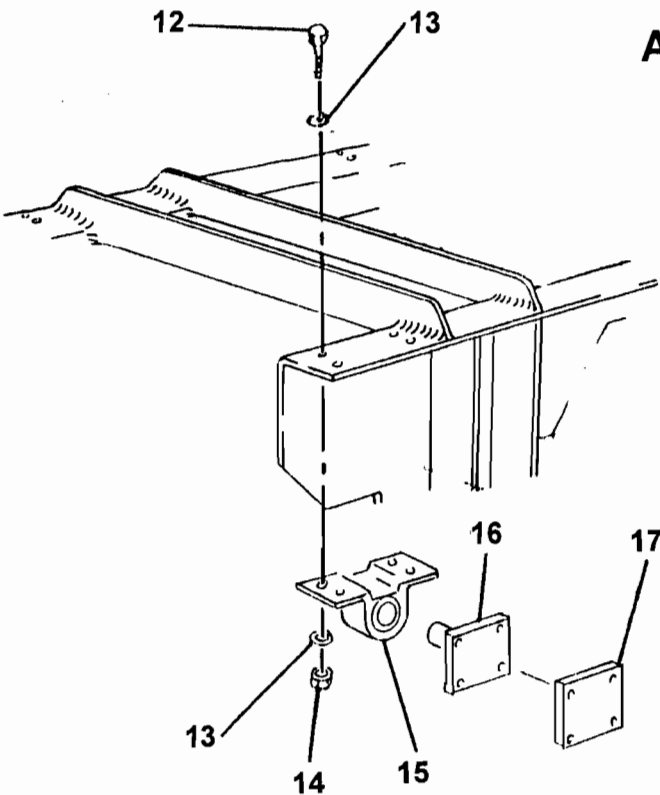

(C)

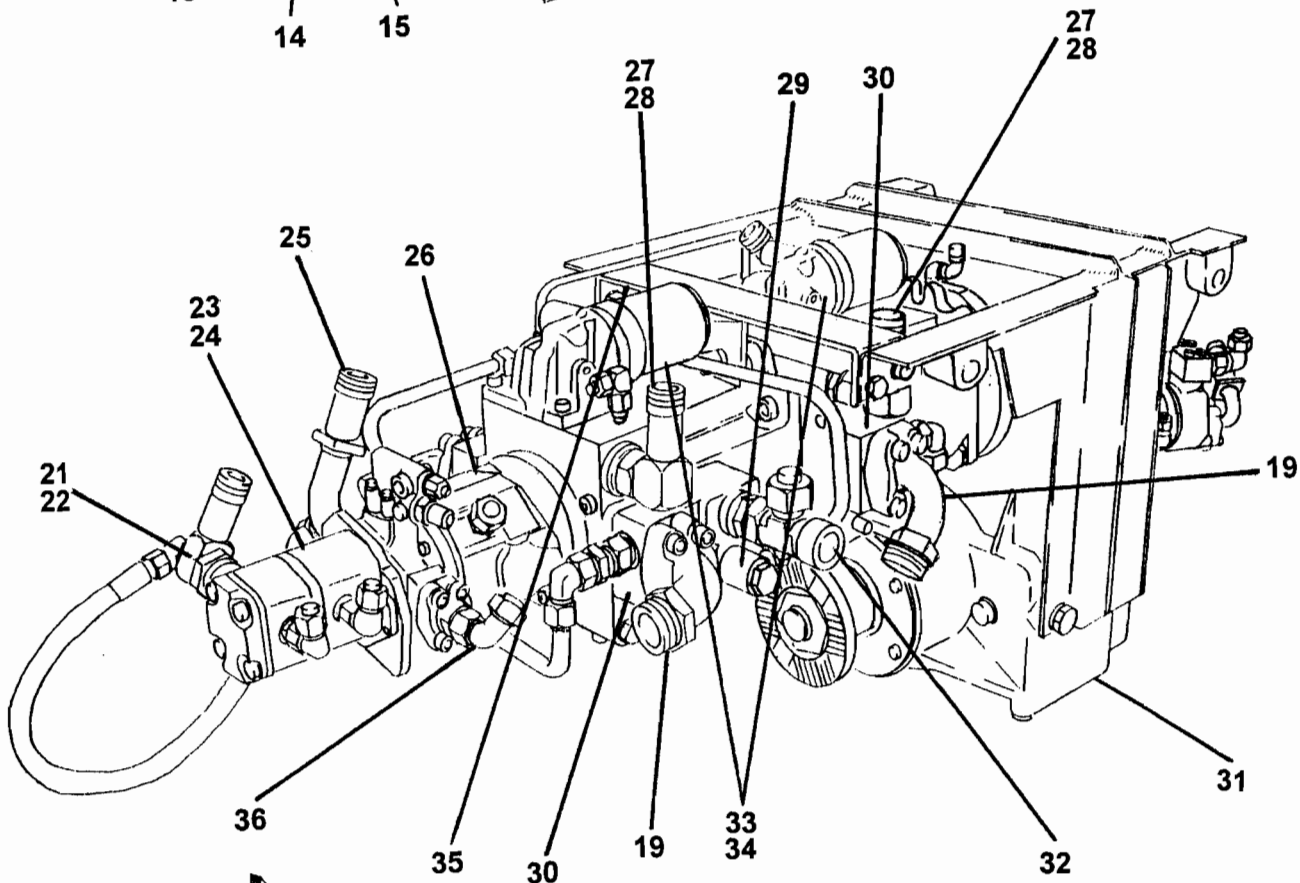

(D)

**APRIL 2000 ~ FEBRUARY 2001**

ITEM NO.	REED'S PARTS NO.	DESCRIPTION					QTY
		1	2	3	4	5	
-1	40-03	Installation, Power Train (Apr 2000 ~ Feb 2001) (See Group 10, Figure 01 for NHA)					Ref
2	801480	• Shaft, Front Drive					1
3	801481	• Shaft, Rear Drive					1
-4	800610	• Group, <b>XT 36</b> Gearbox					1
5	800064	• • Muffler, Air Valve					2
6	800063	• • Valve, Air					1
7	W-103623	• • Assembly, Boom Pump					1
8	W-105629	• • • Seal, Boom Pump Shaft					1
9	801511	• • Adapter, 90L					1
10	801058	• • Manifold, Boom Pump					1
11	801087	• • Mount, PTO Gearbox with Rexroth					1
12		• • Bolt, Hex					16
13		• • Washer					32
14		• • Nut, Lock					16
15	W-103414	• • Buffer, Rubber					4
16	800125	• • Axle, PTO Mount					4
17	800128	• • Plate, PTO Axle Mount					4
18	801778	• • Manifold, Pump					2
19	801503	• • Adapter, 90L					4
20	75861	• • Cover, Bolt Housing					1
21	801510	• • Adapter, 90L					1
22	801516	• • Adapter, STR					1
23	801684	• • Assembly, 4/4CC Gear Pump					1
24	800061	• • • O-Ring, Gear Pump					1
25	801512	• • Adapter, 90L					1
26	W-105650	• • Assembly, Gear Pump (See Group 40, Figure 05 for DET)					1
27	801506	• • Adapter, 90L					2
28	801526	• • Adapter, STR					2
29	801527	• • Adapter, STR					1
30	801057	• • Manifold, Pump					2
31	W-105539	• • Assembly, PTO Gearbox (See Group 40, Figure 06 for DET)					1
32	W-105513	• • • Switch, PTO Gearbox					1
33	801499	• • Filter, Charge Pump					2
34	801500	• • • Element, Charge Pump Filter					2
35	801088	• • Brace, PTO Mount					1
36	W-105075	• • Adapter, 90L					1

DASH (-) ITEM NOT ILLUSTRATED

**AFTER MARCH 2001**

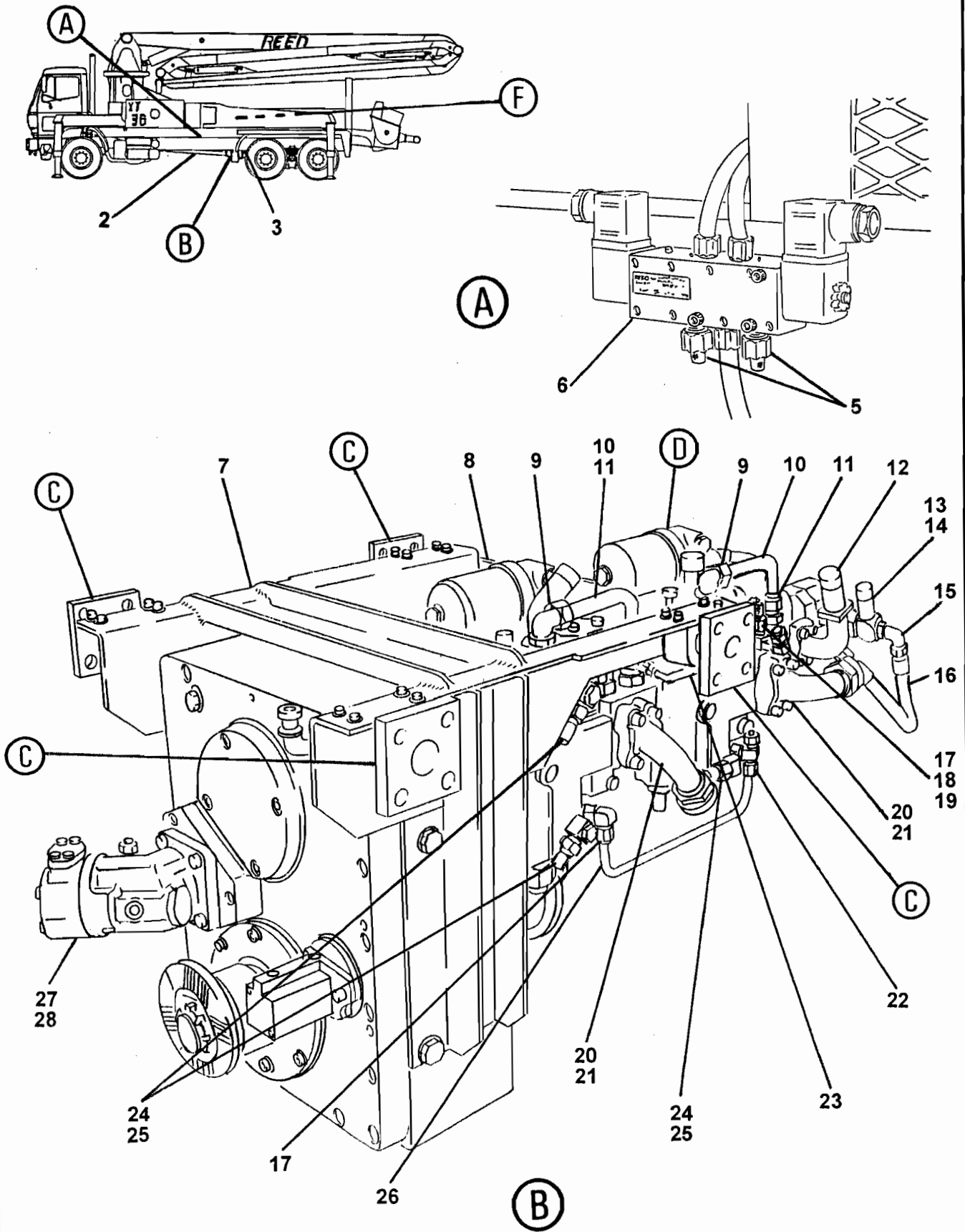

ITEM NO.	REED'S PARTS NO.	DESCRIPTION					QTY
		1	2	3	4	5	
-1	W-105650	Assembly, Gear Pump (See Group 40, Figure 03 and 04 for NHA)					1
2	W-104949	• Valve, Flushing					1
3	W-105651	• Assembly, A10VO28 Gear Pump					1
4	W-105789	• • Kit, A10VO28 Gear Pump Seal					1
5	W-105001	• • Seal, Shaft					1
6	W-105592	• Assembly, A4VG125 Gear Pump					1
7	W-105787	• • Kit, A4VG125 Gear Pump Seal					1
8	W-105788	• • Seal, Shaft					1
9	W-105591	• Assembly, A4VG125 Gear Pump					1
10	W-105785	• • Kit, A4VG125 Gear Pump Seal					1
11	W-105786	• • Seal, Shaft					1

DASH (-) ITEM NOT ILLUSTRATED

ITEM NO.	REED'S PARTS NO.	DESCRIPTION					QTY
		1	2	3	4	5	
-1	802242	Assembly, PTO Gear Box (See Group 40, Figure 03 and 04 for NHA)					1
10	802160	• Cylinder, PTO Shift					1
20	802161	• Adapter, Shaft					1
25	802162	• Adapter, Shaft					1
30	802163	• Cap, Packing Ring					2
35	802164	• Flange, Mounting					1
40	802165	• Flange, Mounting					1
50	802166	• Cover					1
55	802167	• Flange, Mounting					1
60	802168	• Gear, Coupling					1
70	802169	• Gear					1
80	802170	• Gear					1
90	802171	• Gear					1
100	802172	• Shaft, Toothed					1
110	802173	• Shaft, Coupling					1
120	802174	• Shaft, Toothed					1
130	802175	• Shaft, Splined Hollow					1
140	802176	• Flange, Mounting					1
150	802177	• Coupling					1
160	802178	• Spacer					1
170	802179	• Adapter, Shaft					1
175	802180	• Ring, Running					2
180	802181	• Flange					2
190	802182	• Housing, Gearbox					1
200	802183	• Fork, Gear					10
210	802184	• Bearing, Ball					1
220	802185	• Bearing, Ball					1
230	802186	• Bearing, Ball					1
240	802187	• Bearing, Ball					2
245	802188	• Bearing, Ball					1
250	802189	• Bearing					1
260	802190	• Bearing, Roller					1
270	802191	• Bearing, Roller					1
280	802192	• Seal, Radial Oil					1
290	802193	• Seal, Radial Oil					1
300	802194	• Seal, Radial Oil					2
310	802195	• O-Ring					1
315	802196	• O-Ring					1
320	802197	• O-Ring					1
330	802198	• O-Ring					1
335	802199	• O-Ring					2

DASH (-) ITEM NOT ILLUSTRATED



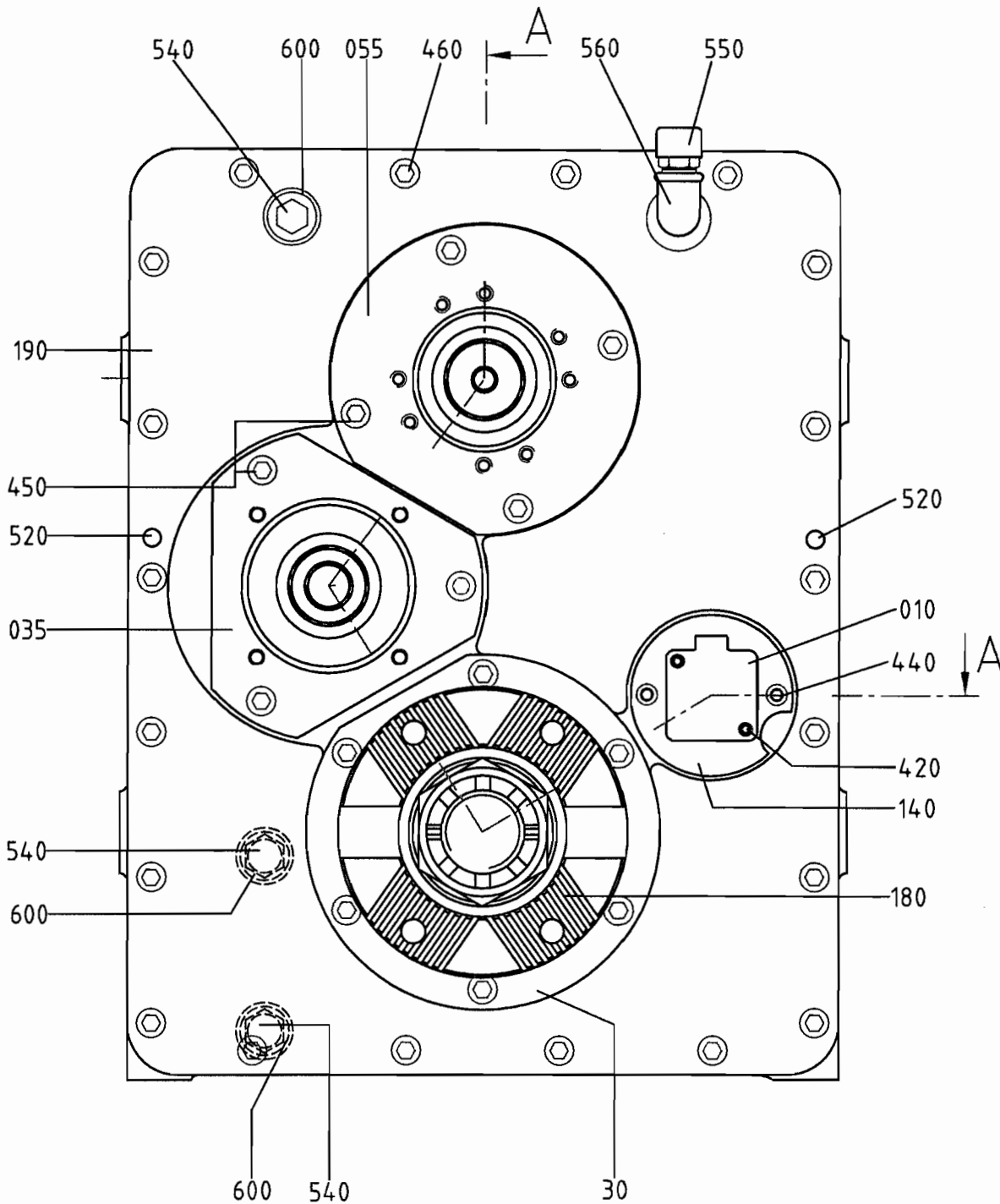



# PTO GEAR BOX ASSEMBLY

XT 36  
PARTS  
GROUP 40  
FIGURE 06  
PAGE 03

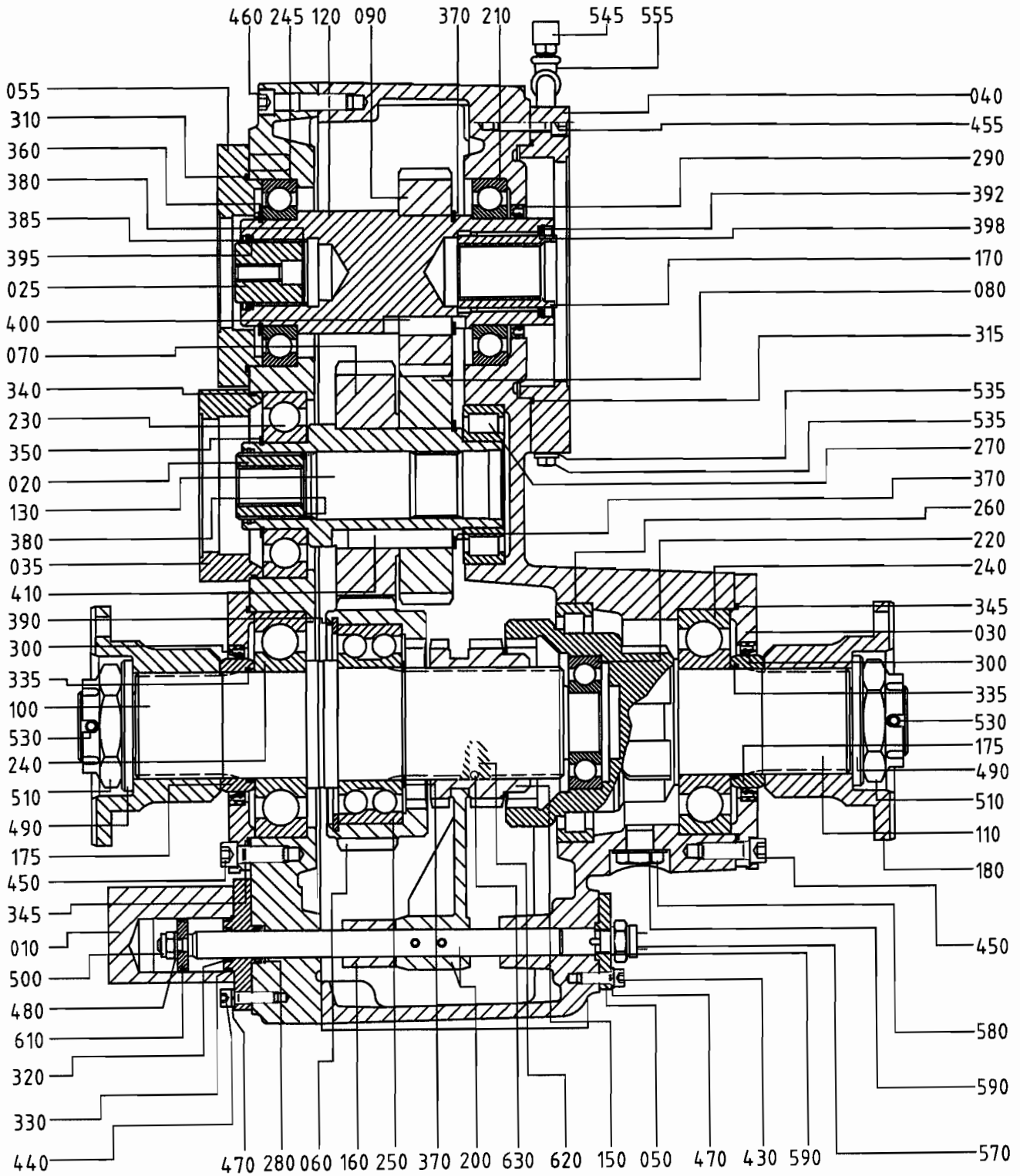

VIEW A-A

ITEM NO.	REED'S PARTS NO.	1 2 3 4 5	DESCRIPTION	QTY
340	802200	•	O-Ring	1
345	802201	•	O-Ring	2
350	802202	•	Ring, Retaining	1
360	802203	•	Ring, Retaining	1
370	802204	•	Ring, Retaining	3
380	802205	•	Ring, Retaining	2
385	802206	•	Ring, Retaining	1
390	802207	•	Ring, Retaining	1
392	802208	•	Ring, Retaining	1
395	802209	•	Disk, Support	1
398	802210	•	Disk, Support	1
400	802211	•	Key	2
410	802212	•	Key	2
420	802213	•	Screw, Socket Head Cap	2
430	802214	•	Screw, Socket Head Cap	2
440	802215	•	Screw, Socket Head Cap	2
450	802216	•	Screw, Socket Head Cap	19
455	802217	•	Screw, Socket Head Cap	8
460	802218	•	Screw, Socket Head Cap	18
470	802219	•	Washer, Lock	4
480	802220	•	Disk	1
490	802221	•	Disk	2
500	802222	•	Nut, Hex	1
510	802223	•	Nut, Castle	2
520	802224	•	Pin	2
530	802225	•	Pin, Spring	2
535	802226	•	Plug, Hex Head	1
540	802227	•	Plug, Hex Head	3
545	802228	•	Filter, Vent	1
550	802229	•	Filter, Vent	1
555	802230	•	Elbow	2
560	802231	•	Elbow	1
570	802232	•	Switch, Limit	1
580	802233	•	Plug, Hex Head	1
-585	802234	•	Ring, Sealing	1
590	802235	•	Ring, Sealing	2
600	802236	•	Ring, Sealing	3
-605	802237	•	Plug, Screw	2
610	802238	•	Assembly, Piston	1
-615	802239	•	Plug, Screw	1
620	802240	•	Spring	1
630	802241	•	Ball, 1/4 IN	1

DASH (-) ITEM NOT ILLUSTRATED

**REED**

**MODEL XT 36 TRUCK MOUNTED  
CONCRETE BOOM PUMP  
ILLUSTRATED PARTS MANUAL**

**XT 36  
PARTS  
GROUP 40  
FIGURE 07  
PAGE 01**

THIS PAGE INTENTIONALLY LEFT BLANK.

**REED TRUCK MOUNTED CONCRETE BOOM PUMP MODEL XT 36 ILLUSTRATED PARTS MANUAL GROUP 50 CONTROLS INSTALLATION CONTAINS THE FOLLOWING FIGURES:**

- FIGURE 00** TABLE OF CONTENTS
- FIGURE 01** CONTROLS INSTALLATION
- FIGURE 02** CAB CONTROLS ASSEMBLY
- FIGURE 03** MAIN CONTROLS ASSEMBLY
- FIGURE 04** LH SIDE OUTRIGGER CONTROLS ASSEMBLY
- FIGURE 05** RH SIDE OUTRIGGER CONTROLS ASSEMBLY
- FIGURE 06** STATIONARY BOOM CONTROLS ASSEMBLY
- FIGURE 07** CABLED REMOTE CONTROL ASSEMBLY
- FIGURE 08** RADIO REMOTE CONTROL ASSEMBLY
- FIGURE 09** SHUNT ASSEMBLY

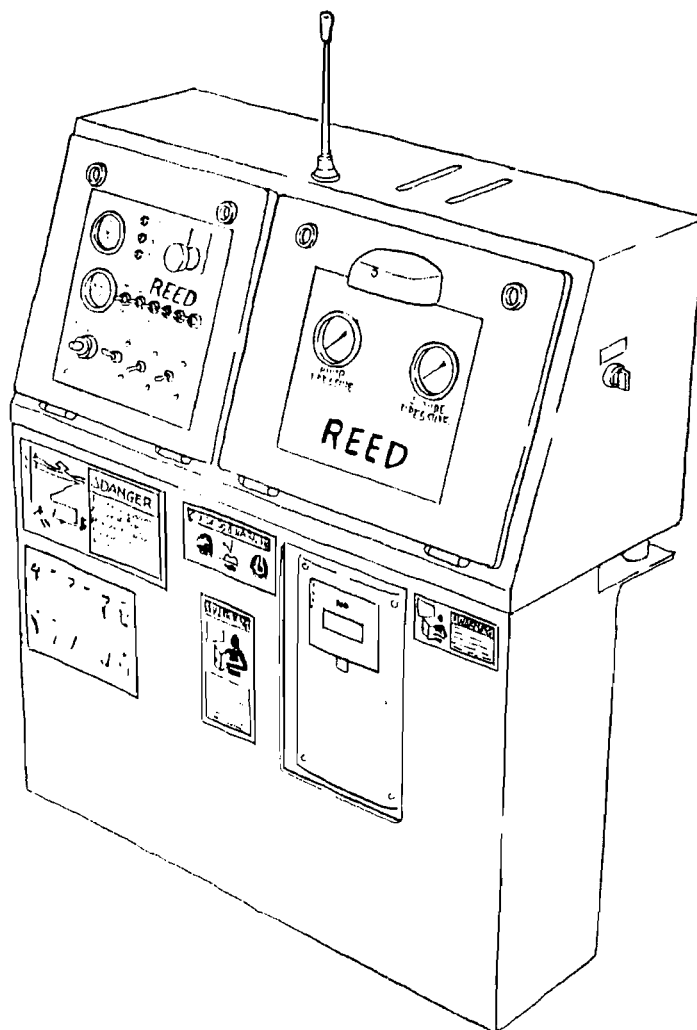

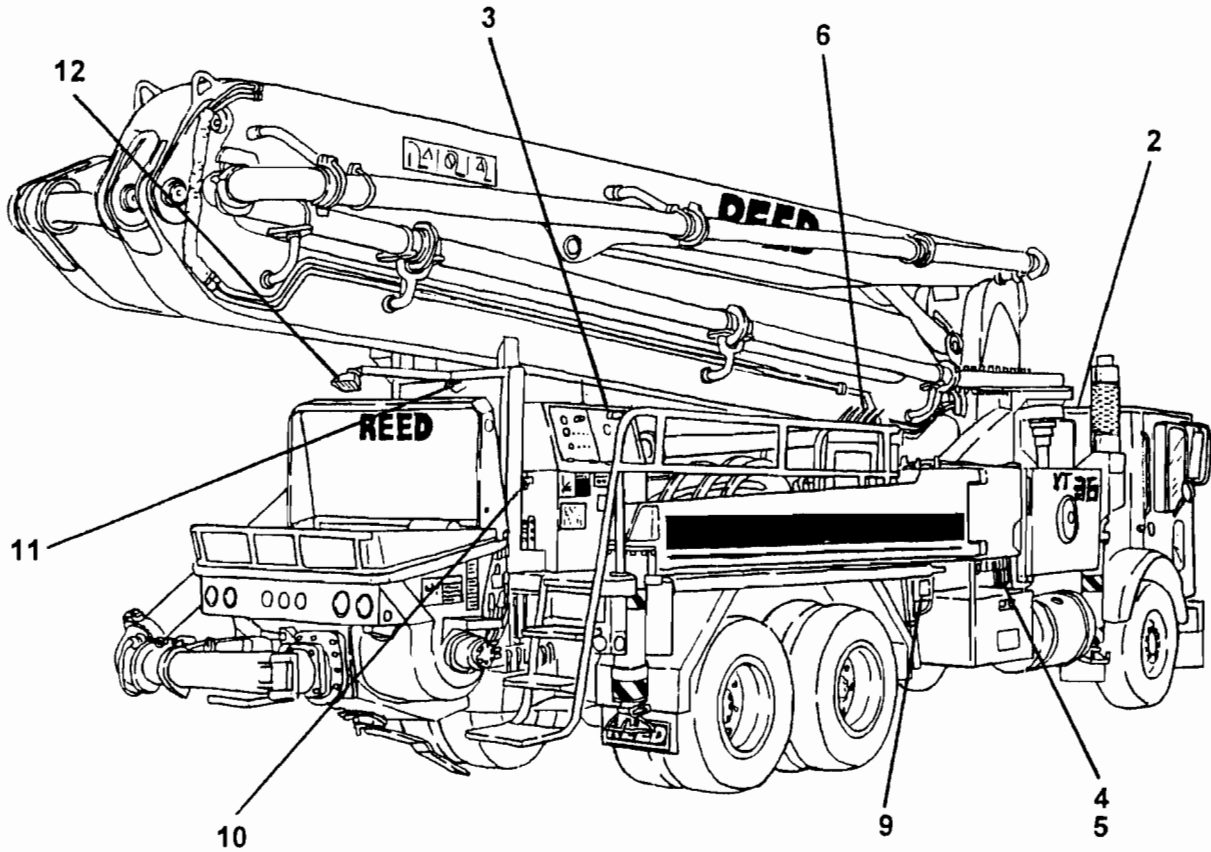

ITEM NO.	REED'S PARTS NO.	DESCRIPTION					QTY
		1	2	3	4	5	
-1	50-01	Installation, <b>XT 36</b> Controls (See Group 10, Figure 01 for NHA)					Ref
2	800710	• Assembly, Cab Controls (See Group 50, Figure 02 for DET)					1
3	50-03	• Assembly, Main Controls (See Group 50, Figure 03 for DET)					1
4	50-04	• Assembly, Driver (L. H.) Side Outrigger Controls (See Group 50, Figure 04 for DET)					1
5	50-05	• Assembly, Passenger (R. H.) Side Outrigger Controls (See Group 50, Figure 05 for DET)					1
6	802135	• Assembly, Stationary Boom Controls (See Group 50, Figure 06 for DET)					1
-7	W-105983	• Assembly, Cabled Remote Control (See Group 50, Figure 07 for DET)					1
-8	W-105982	• Assembly, Radio Remote Control (See Group 50, Figure 08 for DET)					1
9	C-VW00587	• Assembly, Shunt (See Group 50, Figure 09 for DET)					1
10	800347	• Horn, 12V					1
11	800072	• Switch, Limit					1
12	800095	• Light, Floor Work					1

DASH (-) ITEM NOT ILLUSTRATED

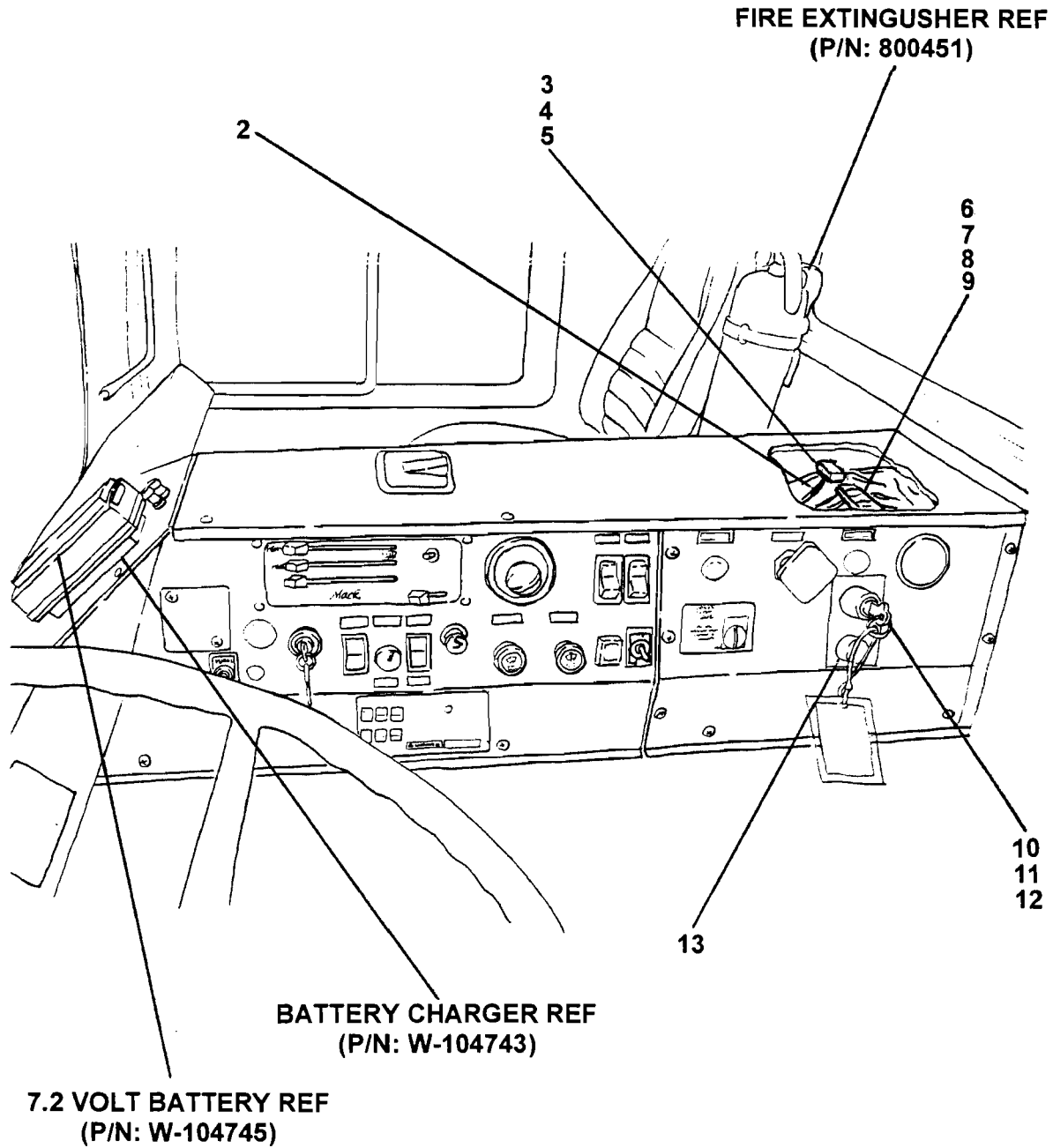



ITEM NO.	REED'S PARTS NO.	DESCRIPTION					QTY
		1	2	3	4	5	
-1	800710	Assembly, Cab Controls (See Group 50, Figure 01 for NHA)					1
2	10194	• Cable, 50 FT					1
3	800433	• Block, Fuse					1
4	800448	• Fuse, ATO 20					2
5	90392	• Fuse, ATO 5					1
6	72820	• Terminal					13
7	75654	• End, Barrier					1
8	72821	• Rail, Terminal					1
9	72824	• Jumper					3
10	800369	• Operator, Key					1
11	800370	• Block, Contact					1
12	800864	• Block, Contact					2
13	800414	• Light, Green Pilot					1
-14	800965	• Switch, Pressure (Located Near Engine)					1
-15	800909	• Switch, Clutch Limit (Located under Clutch Pedal)					1

DASH (-) ITEM NOT ILLUSTRATED

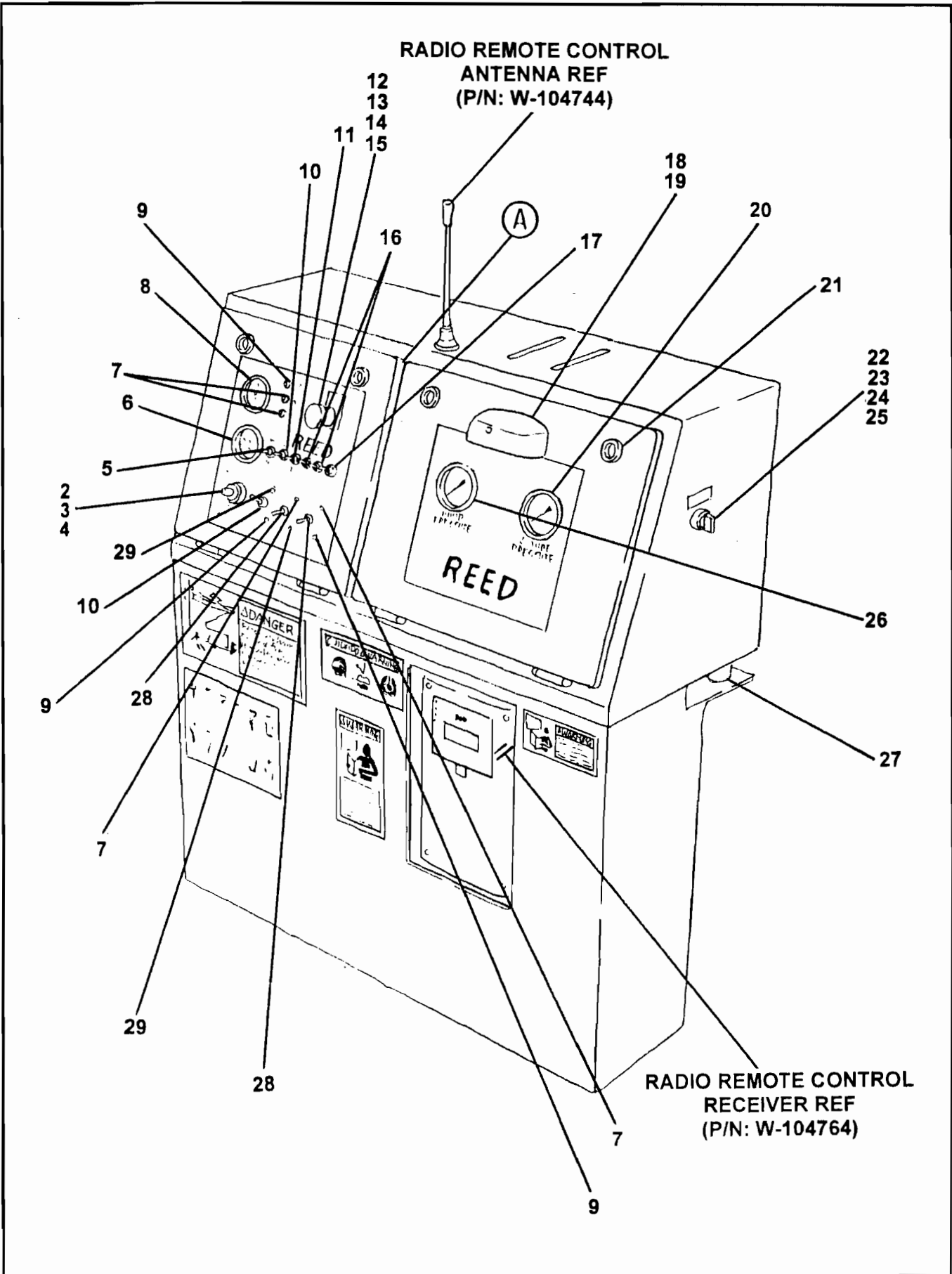

ITEM NO.	REED'S PARTS NO.	DESCRIPTION					QTY
		1	2	3	4	5	
-1	50-03	Assembly, Main Controls (See Group 50, Figure 01 for NHA)					Ref
2		• Assembly, Volume Control					1
3	W-104103	• • Potentiometer					1
4	W-104104	• • Body, Mounting					1
5	W-103976	• Switch, RPM Toggle					1
6	W-100900	• Meter, Hour					1
7	W-105811	• Light, Red Indicator					4
8	W-105823	• Thermometer					1
9	W-105813	• Light, Green Indicator					3
10	W-104090	• Switch, Vibrator / Pump Rev Toggle					2
11	W-104089	• Switch, Light / S-Tube / Pump Rev Toggle					3
12	W-105094	• Button, Emergency Stop					1
13	W-105095	• Element, Emergency Stop Contact					1
14	W-102278	• Nameplate, Emergency Stop					1
15	W-104083	• Light, Emergency					1
16	W-104091	• Switch, Lube / Horn Toggle					1
17	W-104089	• Switch, Lever					1
18	W-101033	• Assembly, Light					1
19	W-104101	• • Bulb, Replacement					1
20	70366	• Gauge, 3000 PSI Pressure					1
21		• Lock, Twist					4
22	W-100968	• Switch, A & B Momentary Rotary					1
23	W-100969	• Contact, A & B Switch					3
24	W-103735	• Bridge, A & B Switch					1
25	W-100287	• Base, A & B Switch					1
26	79831	• Gauge, 6000 PSI Pressure					1
27		• Mount, Rubber					A/R
28	72826	• Switch, On - On					1
29	W-105812	• Light, Yellow Indicator					2

DASH (-) ITEM NOT ILLUSTRATED

# REED

## MAIN CONTROLS ASSEMBLY

XT 36  
PARTS  
GROUP 50  
FIGURE 03  
PAGE 03

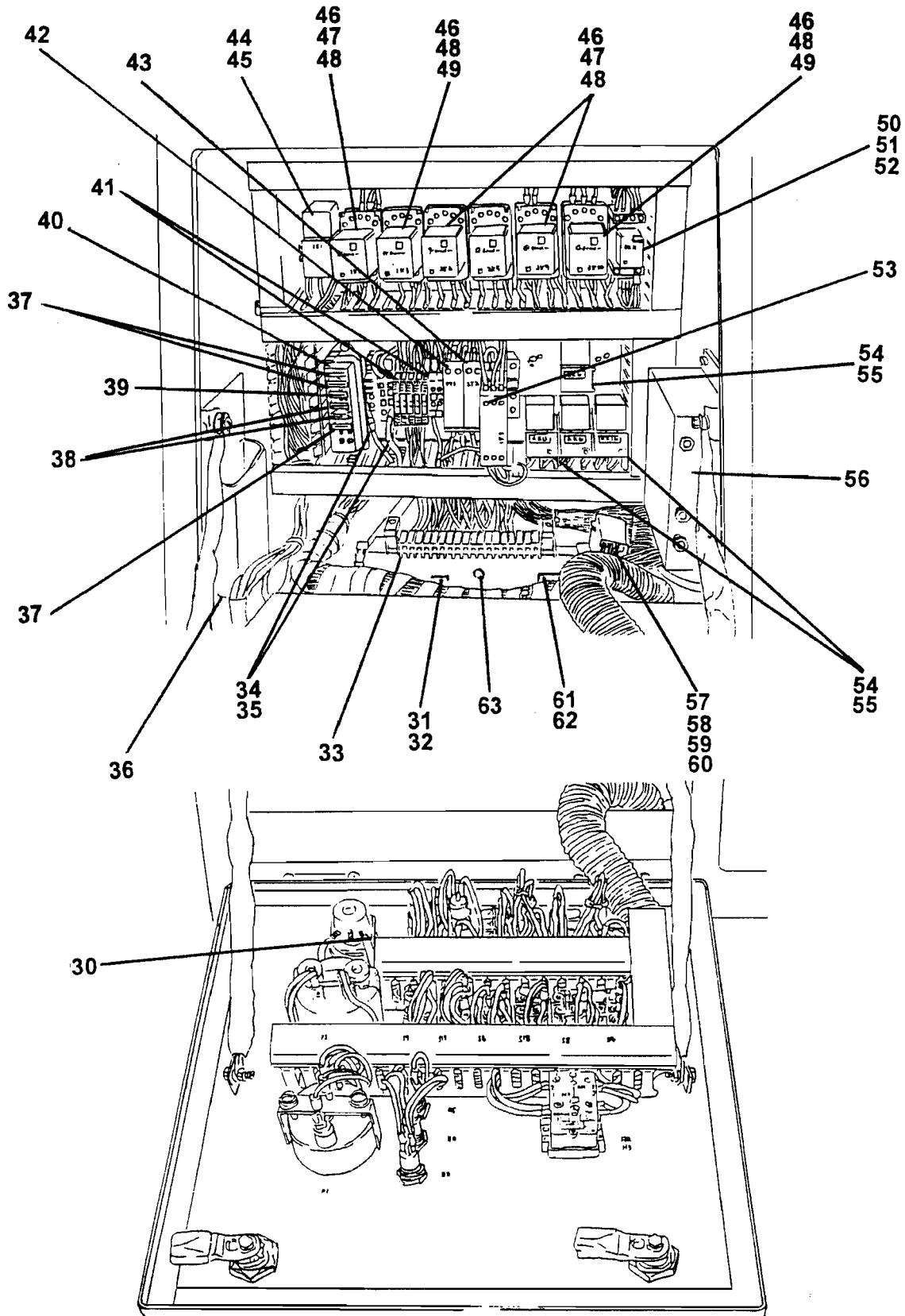

(A)

ITEM NO.	REED'S PARTS NO.	DESCRIPTION					QTY
		1	2	3	4	5	
30	W-104118	• Resistor, 100 OHM					1
31	W-100710	• Contact, 24 Pin Female (A)					1
32	W-101553	• Contact, 24 Pin Housing (A)					1
33	W-102577	• Block, Terminal					1
34	W-105817	• Clamp					2
35	W-105818	• Plate, End					2
36	W-104099	• Bag, Circuit Diagram					1
37	W-101921	• Fuse, 10 AMP					3
38	W-104096	• Fuse, 20 AMP					2
39	W-101922	• Fuse, 5 AMP					1
40	W-101577	• Holder, 8 Type Fuse					1
41	W-104185	• Diode					4
42	W-105331	• Relay, Time					1
43	W-105815	• Relay					1
44	W-105619	• Socket, Relay					1
45	W-104122	• Relay					1
46	W-104094	• Clip					6
47	W-100178	• Clip					4
48	W-104093	• Relay					6
49	W-104895	• Clip					2
50	W-103974	• Socket, Relay					1
51	W-105046	• Relay, Type 55.34					1
52	W-104860	• Clip					1
53	W-105814	• Element, Emergency Stop					1
54	W-100986	• Socket,, Relay Bosch					4
55	W-104117	• Relay, Bosch					4
56	800461	• Box, Black					1
57	W-103693	• Contact, 8 Pin Female (C)					1
58	W-105816	• Contact, 8 Pin Housing (C)					1
59	W-103695	• Contact, Crimp (C)					1
60	W-103697	• Contact, Crimp (C)					1
61	W-104022	• Contact, 16 Pin Female (B)					1
62	W-104097	• Contact, 16 Pin Housing (B)					1
63	W-104669	• Condenser					1

DASH (-) ITEM NOT ILLUSTRATED

# REED

## DRIVER SIDE (LEFT HAND) OUTRIGGER CONTROLS ASSEMBLY

XT 36  
PARTS  
GROUP 50  
FIGURE 04  
PAGE 01

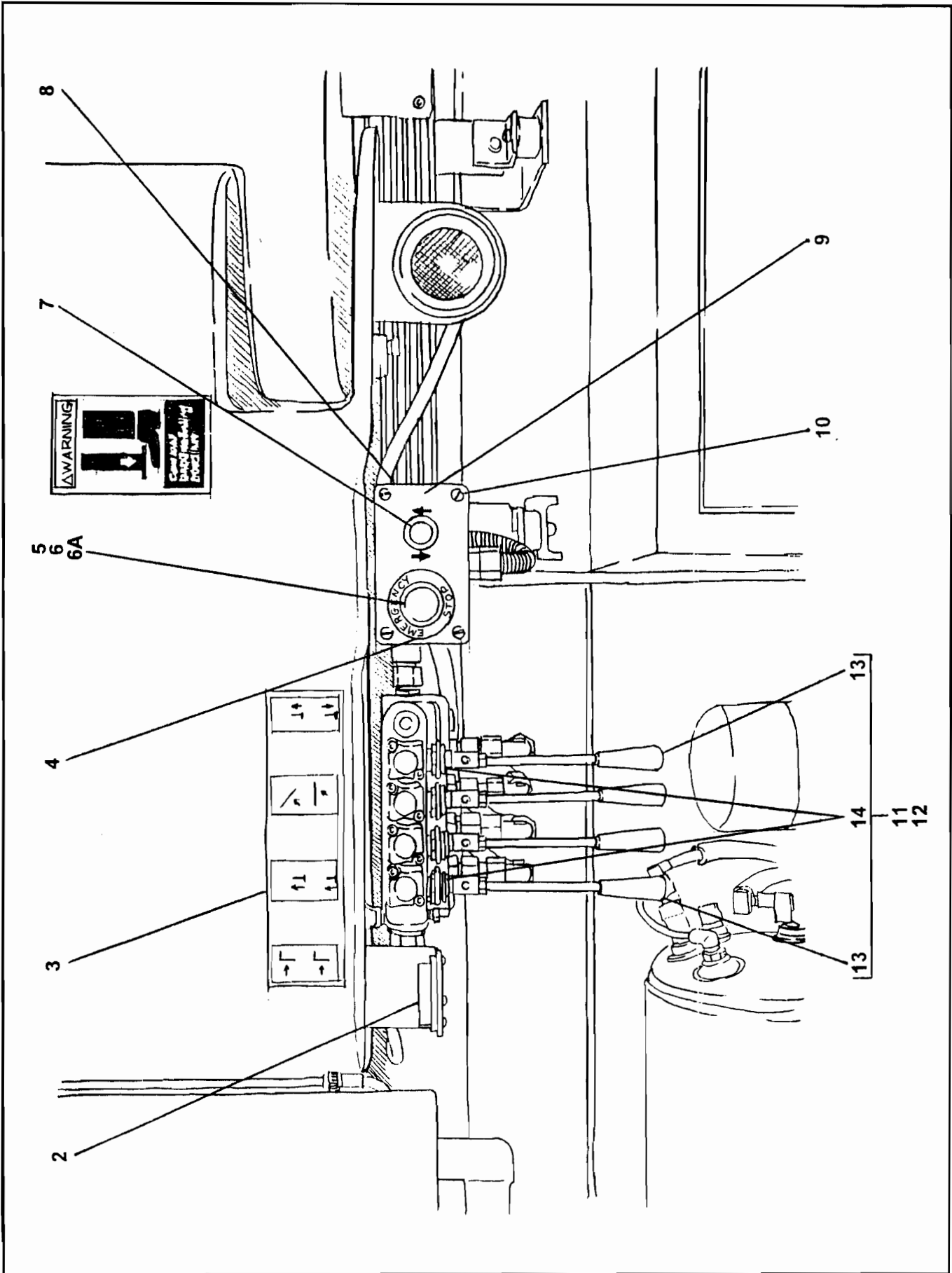

**DRIVER SIDE (LEFT HAND)  
OUTRIGGER CONTROLS ASSEMBLY**

ITEM NO.	REED'S PARTS NO.	DESCRIPTION					QTY
		1	2	3	4	5	
-1	50-04	Assembly, Driver (L. H.) Side Outrigger Controls (See Group 50, Figure 01 for NHA)					Ref
2	800099	• Level, Bubble					1
3	802270	• Nameplate, <b>XT 36</b> Left Side Outrigger					1
4	W-102278	• Nameplate, Emergency					1
5	W-105094	• Button, Emergency Stop					1
6	W-105095	• Element, Emergency Stop Contact					1
6A	W-104083	• Light, Emergency					1
7	W-100569	• Button, Push Operation					1
8		• Box, Non-Keyed Junction					1
9		• Decal, Non-Keyed Junction Box					1
10	W-103735	• Screw, Twist Lock Spring (attaching parts)					4
11	802143	• Assembly, L. H. Outrigger Control Valve					1
12		• • Lever					4
13		• • • Lever, Knob					1
14		• • • Boot, Rubber					1

DASH (-) ITEM NOT ILLUSTRATED

## PASSENGER SIDE (RIGHT HAND) OUTRIGGER CONTROLS ASSEMBLY

XT 36  
PARTS  
GROUP 50  
FIGURE 05  
PAGE 01

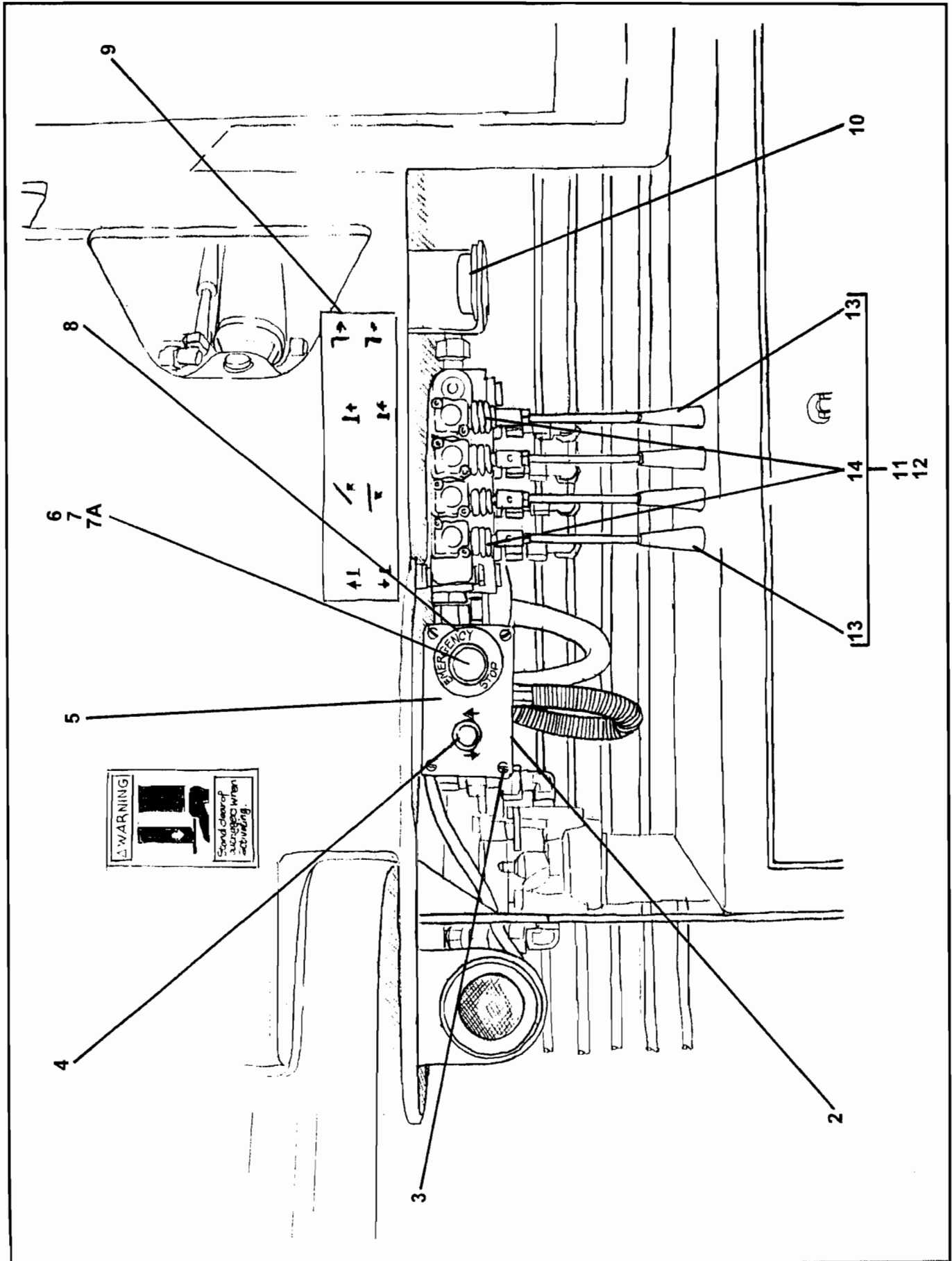



ITEM NO.	REED'S PARTS NO.	DESCRIPTION					QTY
		1	2	3	4	5	
-1	50-05	Assembly, Passenger (R. H.) Side Outrigger Controls (See Group 50, Figure 01 for NHA)					Ref
2		• Box, Keyed Junction					1
3	W-103735	• Screw, Twist Lock Spring (attaching parts)					4
4	C-EI001	• Button, Push Operation					1
5		• Decal, Keyed Junction Box					1
6	W-105094	• Button, Emergency Stop					1
7	W-105095	• Element, Emergency Stop Contact					1
7A	W-104083	• Light, Emergency					1
8	W-102278	• Nameplate, Emergency					1
9	802271	• Nameplate, <b>XT 36</b> Right Side Outrigger					1
10	800099	• Level, Bubble					1
11	802142	• Assembly, R. H. Outrigger Control Valve					1
12		• • Lever					4
13		• • • Lever, Knob					1
14		• • • Boot, Rubber					1

DASH (-) ITEM NOT ILLUSTRATED

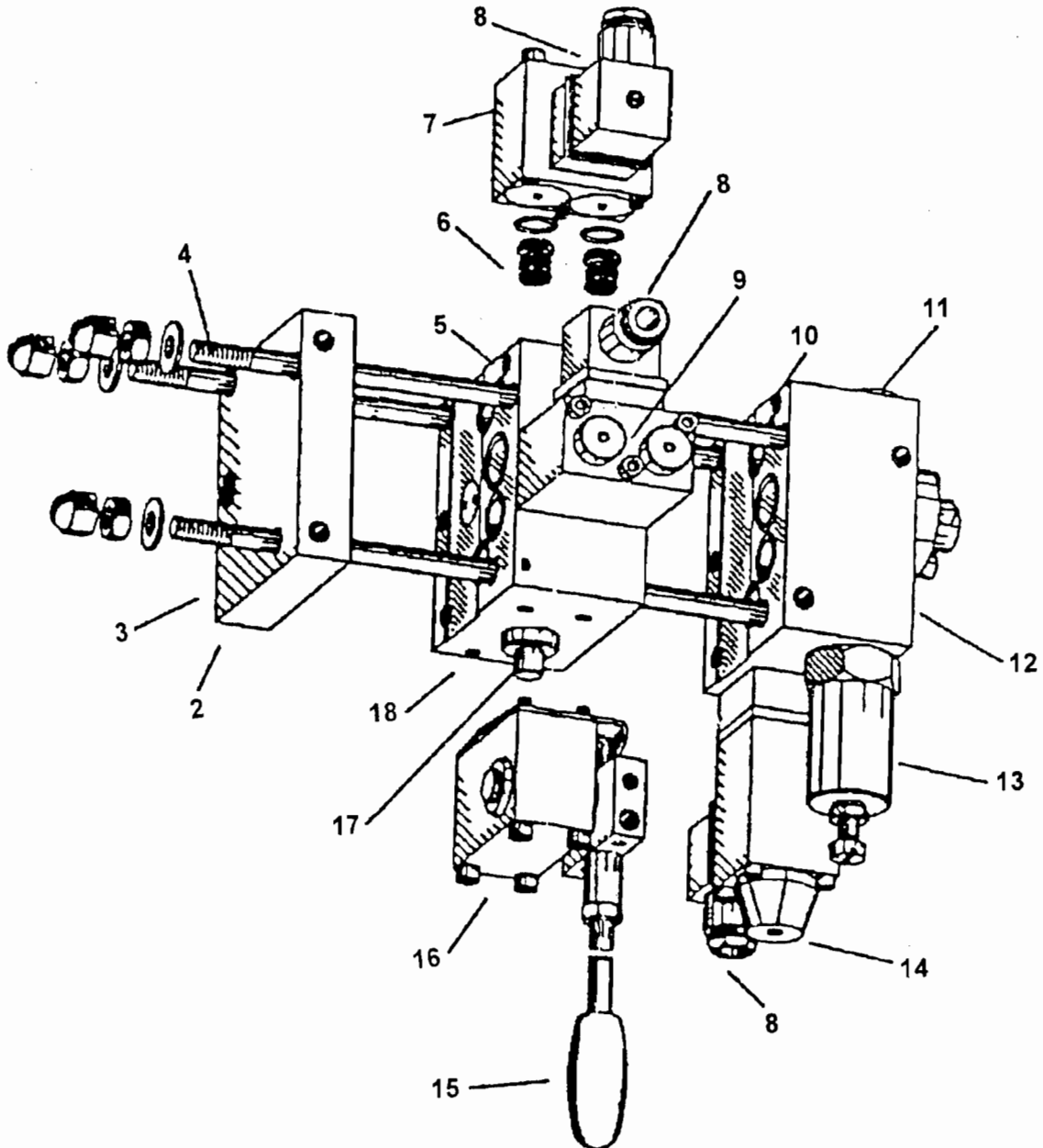

ITEM NO.	REED'S PARTS NO.	DESCRIPTION					QTY
		1	2	3	4	5	
-1	802135	Assembly, Boom Controls (See Group 50, Figure 01 for NHA)					Ref
2		• Plate, End					1
3		• Valve, Check					1
4		• Set, Tension Rod					1
5		• Kit, Valve Section Seal					6
6		• Valve, Press Reducing					6
7		• Solenoid, Actuation					6
8		• Plug, Solenoid					13
9		• Solenoid, Function					6
10		• Kit, Connection Block Seal					1
11		• Valve, Pilot Press Reducing					1
12		• Block, Connection					1
13		• Valve, Pressure Limiting					1
14		• Valve, Directional Seated					1
15		• Lever, Hand					6
16		• Housing, Actuation					6
17		• Spool					6
18		• Valve, Section					6
-19	802272	• Nameplate, Boom Valve					1

DASH (-) ITEM NOT ILLUSTRATED

# REED

## CABLED REMOTE CONTROL ASSEMBLY

**XT 36**  
**PARTS**  
GROUP 50  
FIGURE 07  
PAGE 01

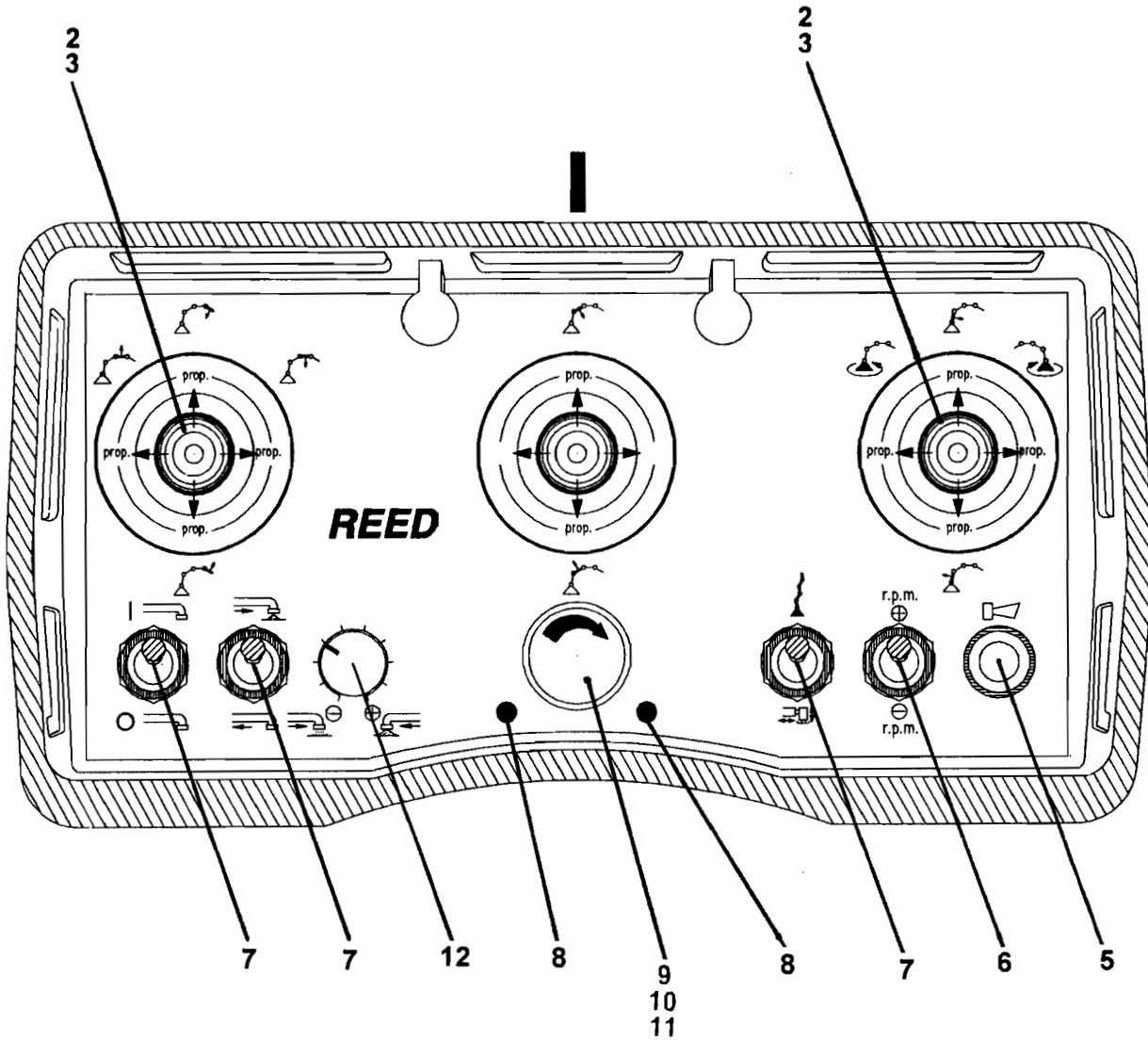

REVISION:

ITEM NO.	REED'S PARTS NO.	DESCRIPTION					QTY
		1	2	3	4	5	
-1	W-105983	Assembly, Cabled Remote Control (See Group 50, Figure 01 for NHA)					Ref
2		• Switch, Joy Stick Control					3
3		• • Boot, Rubber					3
-4		• Strap, Shoulder					1
5	3.740.1020	• Switch, O - Mom Push Button					1
6	3.740.1017	• Switch, Mom - O - Mom Toggle					1
7	3.740.1016	• Switch, On - O - On Toggle					3
8		• • Indicator, Light					2
9		• • Switch, Emergency Stop					1
10		• • • Knob, with Key					1
11		• • • Switch, Contact					1
12	3.980.1156	• • Potentiometer, with Knob					1

DASH (-) ITEM NOT ILLUSTRATED

# REED

## RADIO REMOTE CONTROL ASSEMBLY

XT 36  
PARTS  
GROUP 50  
FIGURE 08  
PAGE 01

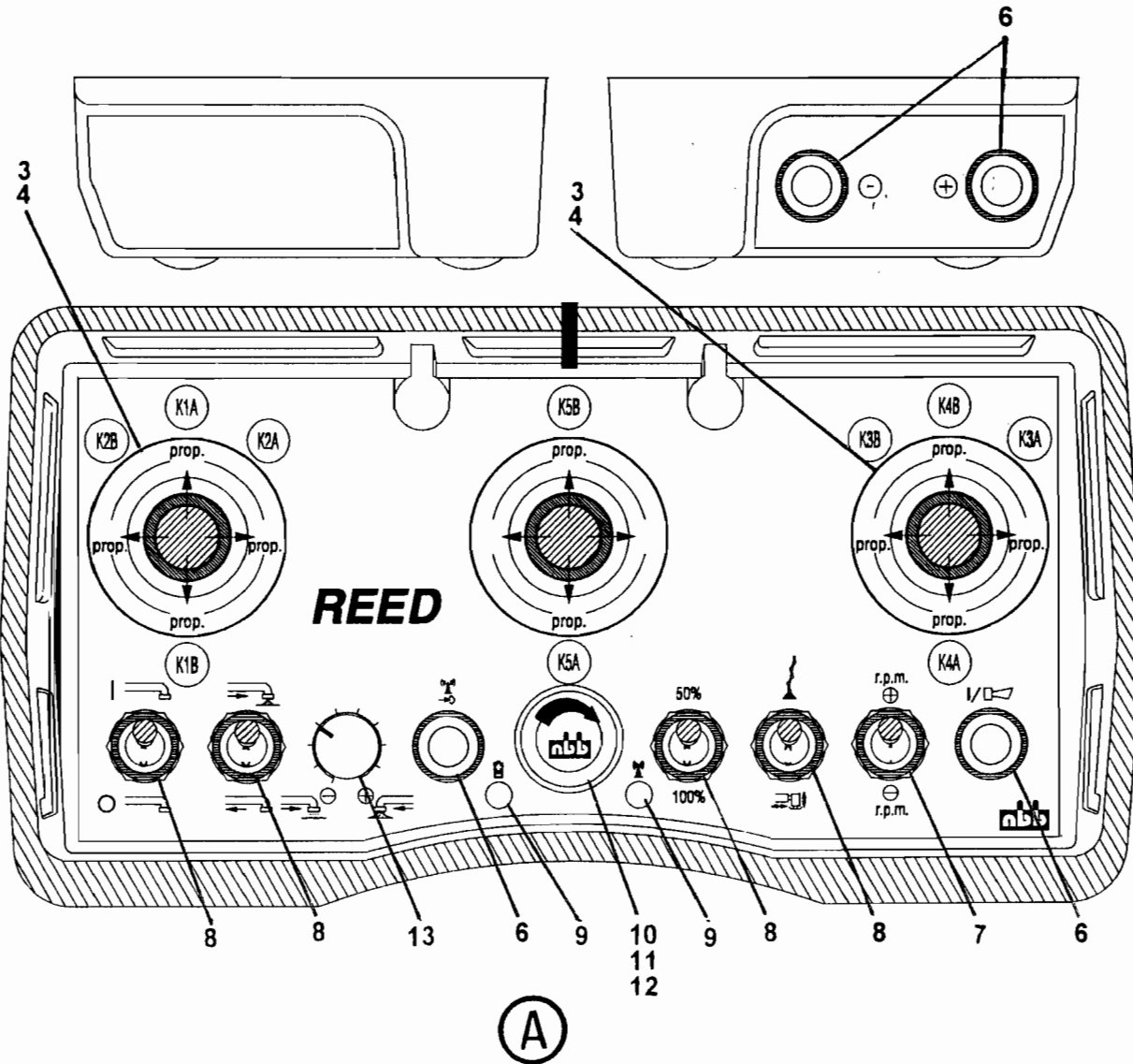
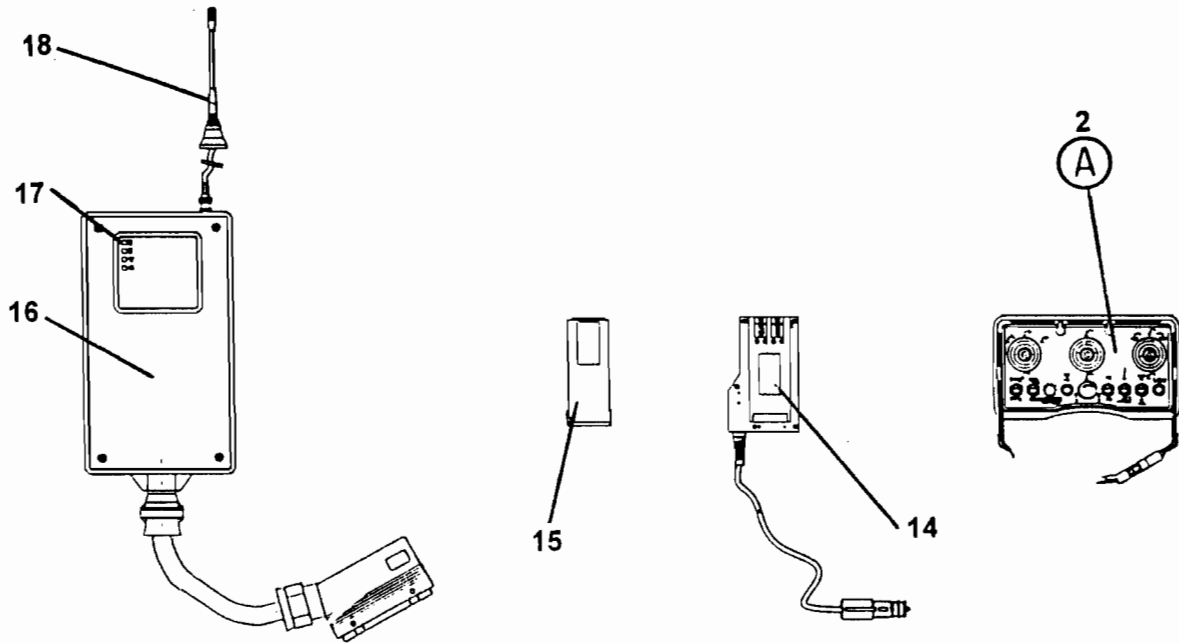

ITEM NO.	REED'S PARTS NO.	DESCRIPTION					QTY
		1	2	3	4	5	
-1	W-105983	Assembly, Radio Remote Control (See Group 50, Figure 01 for NHA)					Ref
2	W-106051	• Transmitter, Radio Remote Control					1
3		• • Switch, Joy Stick Control					3
4		• • • Boot, Rubber					1
-5		• • Strap, Shoulder					1
6	3.740.1020	• • Switch, O – Mom Push Button					2
7	3.740.1017	• • Switch, O – Mom Toggle					1
8	3.740.1016	• • Switch, On – O - On Toggle					4
9		• • Indicator, Light					2
10		• • Switch, Emergency Stop					1
11		• • • Knob, with Key					1
12		• • • Switch, Contact					1
13	3.980.1156	• • Potentiometer, with Knob					1
14	W-104743	• Charger, Battery (See Group 50, Figure 02 for REF)					1
15	W-104745	• Battery, 7.2V (See Group 50, Figure 02 for REF)					1
16	W-106052	• Receiver, Radio Remote Control (See Group 50, Figure 03 for REF)					1
17		• • Indicator, Light					5
18	W-104744	• Antenna, Radio Remote Control (See Group 50, Figure 03 for REF)					1

DASH (-) ITEM NOT ILLUSTRATED

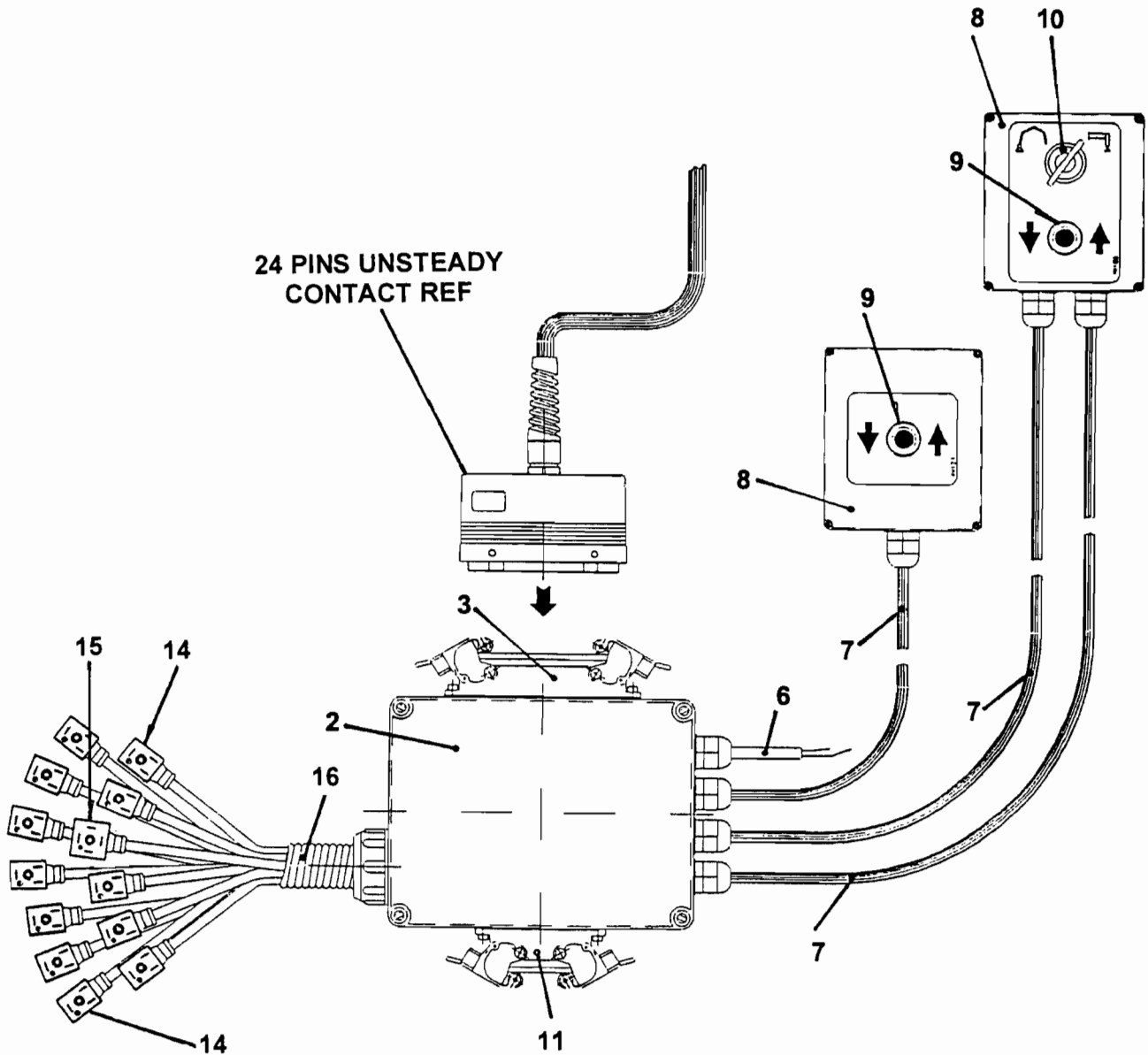



ITEM NO.	REED'S PARTS NO.	DESCRIPTION					QTY
		1	2	3	4	5	
-1	C-VW00587	Assembly, Shunt (See Group 50, Figure 01 for NHA)					Ref
2	C-WW00230	• • Box, Connector 214 X 162 X 92					1
3		• • Plug, 24 Points Contact					1
-4	C-WW00154	• • • Plug					1
-5	C-WW00167	• • • Case, Plug					1
6	C-WW00116	• • Cable, Electric 1.6 m					1
7	C-WW00265	• • Cable, Electric 4 m					3
8	C-ES001	• • Box, Junction					2
9	C-EI001	• • Switch					2
10	C-WW00190	• • Switch, 2 Position Key					1
11		• • Plug, 10 Points Auxiliary Contact					1
-12	C-WW00011	• • • Plug					1
-13	C-WW00037	• • • Case, Plug					1
14	C-WW00065	• • Plug, Rectangular with Cable					12
15	C-WW00175	• • Plug, Square with Electric Cable					1
16	C-WW00100	• • Cable, 1.5 m Sheath					1

DASH (-) ITEM NOT ILLUSTRATED

**REED**

**MODEL XT 36 TRUCK MOUNTED  
CONCRETE BOOM PUMP  
ILLUSTRATED PARTS MANUAL**

**XT 36  
PARTS  
GROUP 50  
FIGURE 10  
PAGE 01**

THIS PAGE INTENTIONALLY LEFT BLANK.

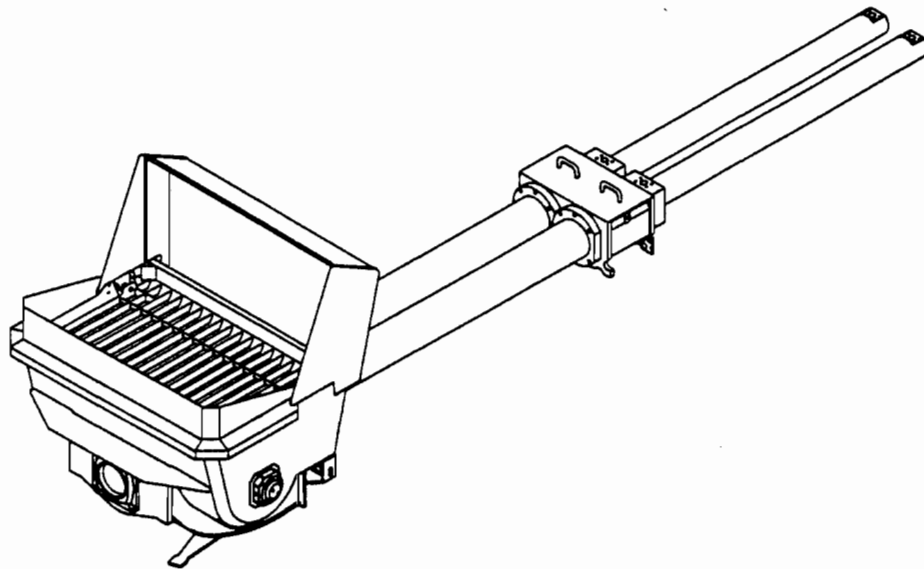

**REED TRUCK MOUNTED CONCRETE BOOM PUMP MODEL XT 36 ILLUSTRATED PARTS MANUAL GROUP 60 PUMPING TRAIN INSTALLATION CONTAINS THE FOLLOWING FIGURES:**

<b>FIGURE 00</b>	<b>TABLE OF CONTENTS</b>
<b>FIGURE 01</b>	<b>PUMPING TRAIN INSTALLATION</b>
<b>FIGURE 02</b>	<b>SWING VALVE ASSEMBLY</b>
<b>FIGURE 03</b>	<b>TILTING DRIVE ASSEMBLY</b>
<b>FIGURE 04</b>	<b>TILTING CYLINDER ASSEMBLY</b>
<b>FIGURE 05</b>	<b>CONCRETE CYLINDER ASSEMBLY</b>
<b>FIGURE 06</b>	<b>WATER BOX ASSEMBLY</b>
<b>FIGURE 07</b>	<b>HYDRAULIC DRIVE CYLINDER ASSEMBLY</b>
<b>FIGURE 08</b>	<b>DRIVE CYLINDER SUB-ASSEMBLY</b>



# PUMPING TRAIN INSTALLATION

XT 36  
PARTS  
GROUP 60  
FIGURE 01  
PAGE 01

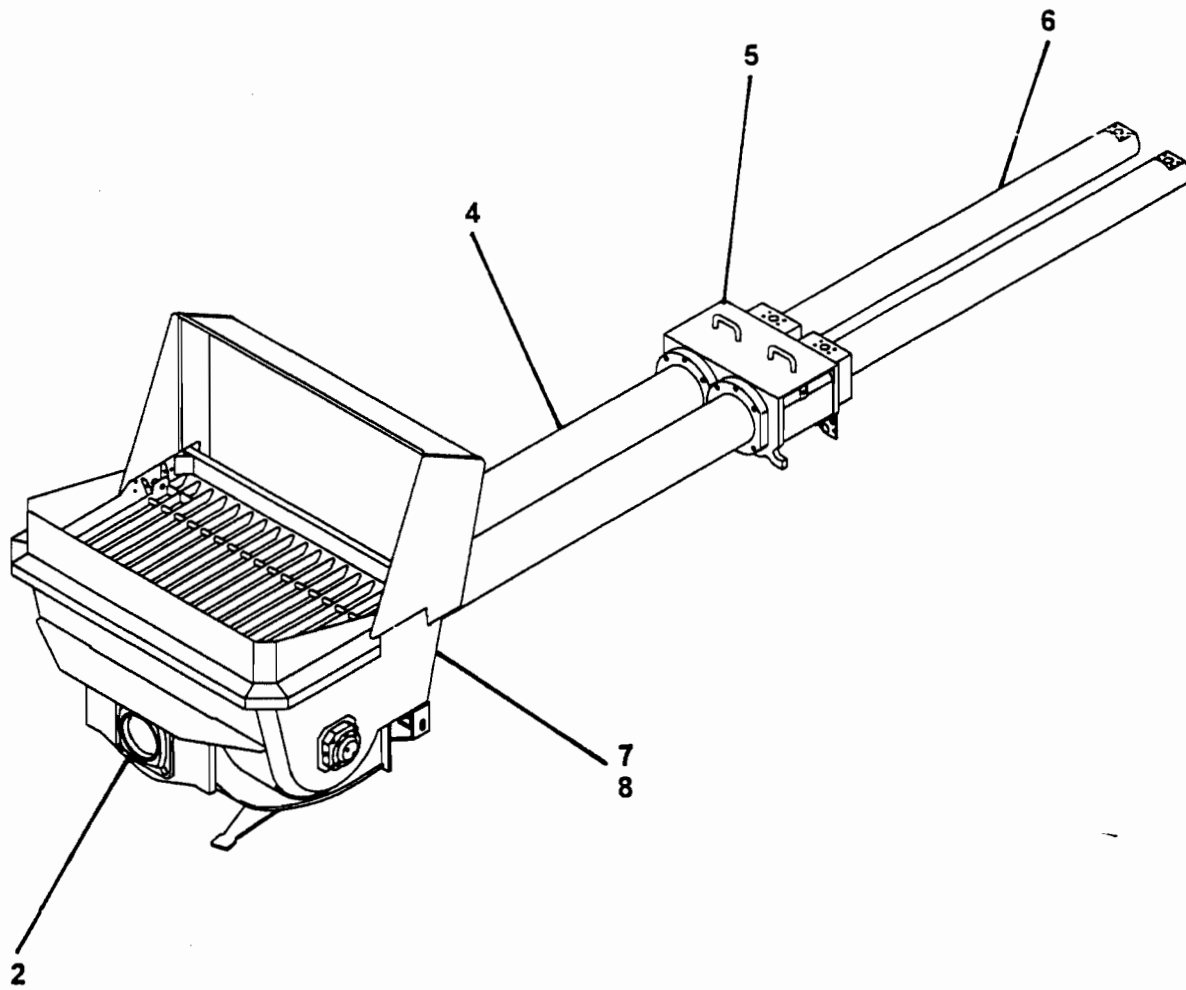



# PUMPING TRAIN INSTALLATION

**XT 36**  
**PARTS**  
GROUP 60  
FIGURE 01  
PAGE 02

ITEM NO.	REED'S PARTS NO.	DESCRIPTION					QTY
		1	2	3	4	5	
-1	60-01	Installation, Pumping Train (See Group 10, Figure 01 for NHA)					Ref
2	B-174020	• Assembly, Swing Valve (See Group 60, Figure 02 for DET)					1
-3	B-174030	• Assembly, Tilting Drive (See Group 60, Figure 03 for DET)					1
4	B-124013	• Assembly, Concrete Cylinder (See Group 60, Figure 05 for DET)					1
5	B-143000	• Assembly, Water Box (See Group 60, Figure 06 for DET)					1
6	60-06	• Assembly, Hydraulic Drive Cylinder (See Group 60, Figure 07 for DET)					1
7	20-01	• Installation, Hopper (See Group 20, Figure 01 for REF)					Ref
8	B-184000	• System, Central Lubrication (See Group 20, Figure 02 for REF)					Ref

DASH (-) ITEM NOT ILLUSTRATED



# SWING VALVE ASSEMBLY

XT 36  
PARTS  
GROUP 60  
FIGURE 02  
PAGE 01

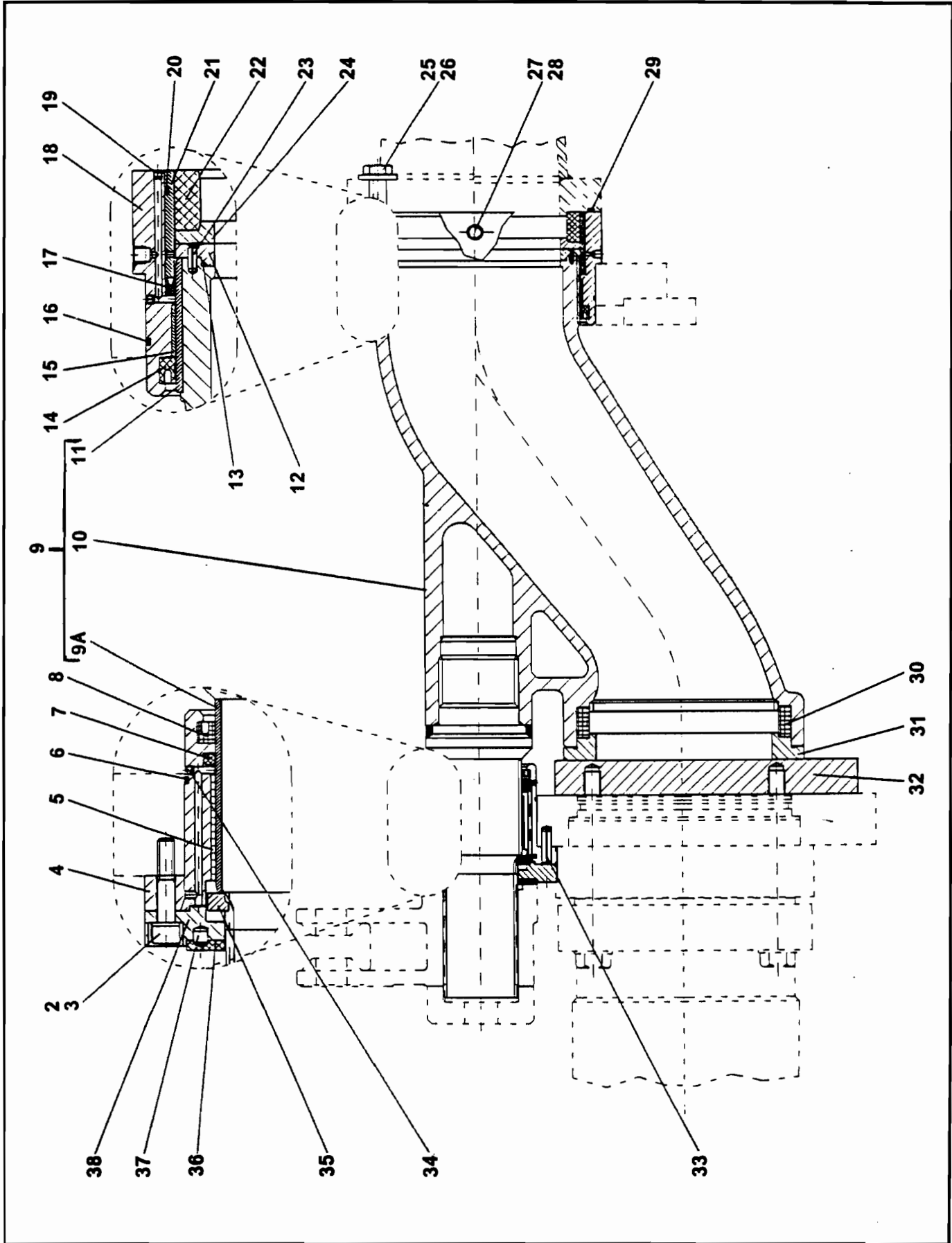

REVISION:

**REED****SWING VALVE ASSEMBLY**
**XT 36**  
**PARTS**  
 GROUP 60  
 FIGURE 02  
 PAGE 02

	REED'S PARTS NO.	DESCRIPTION					QTY
		1	2	3	4	5	
-1	B-174020	Assembly, Swing Valve (See Group 60, Figure 01 for NHA)					Ref
2	W-103151	• Screw, M12					3
3	W-103113	• Washer, Spring A12					3
4	B-174024	• Housing, Small Bearing					1
5	W-100237	• Bushing					1
6	W-100486	• O-Ring					2
7	W-100485	• O-Ring					2
8	W-100484	• Ring, Groove					1
9	W-105223	• Assembly, Swing Tube					1
9A	B-172105	• • Bushing, Small					1
10	B-174089	• • Valve, Swing DN 200					1
11	B-172107	• • Bushing, Big					1
12	B-174027	• Ring, Sliding					1
13	W-100625	• O-Ring					1
14	W-100479	• Ring, Groove					1
15	W-100236	• Ring, Outlet Wear					1
16	W-100481	• O-Ring					1
17	W-103078	• Foreseal					1
18	B-174022	• Housing, Big Bearing					1
19	W-100499	• Screw, M5 Set					2
20	W-103365	• O-Ring					1
21	B-174023	• Ring, Spacer					1
22	W-100262	• Ring, Outlet Wear					1
23	W-103077	• Pin, Spring Type Straight					2
24	B-174028	• Ring, Sliding					1
25	W-101589	• Screw, M20 Hex					4
26	W-102110	• Washer, A20					4
27	W-101621	• Screw, M8 Hex					1
28	W-101269	• Ring					1
29	W-101588	• O-Ring					1
30	W-103378	• Ring, Wear Ring Tension					1
31	B-174087	• Ring, Wear					1
32	B-174091	• Plate, Spectacle					1
33	W-103076	• Pin, Spring Type Straight					1
34	W-102710	• Screw, M4 Set					4
35	B-174026	• Profile					1
36	B-173012	• Washer, Phenolic Axial Bearing					1
37	W-103080	• Pin, Cylindrical					1
38	B-174025	• Flange					1

DASH (-) ITEM NOT ILLUSTRATED

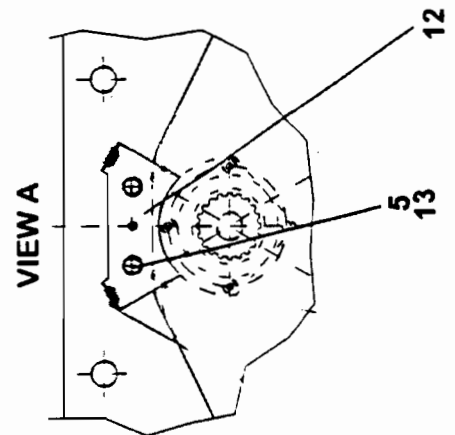
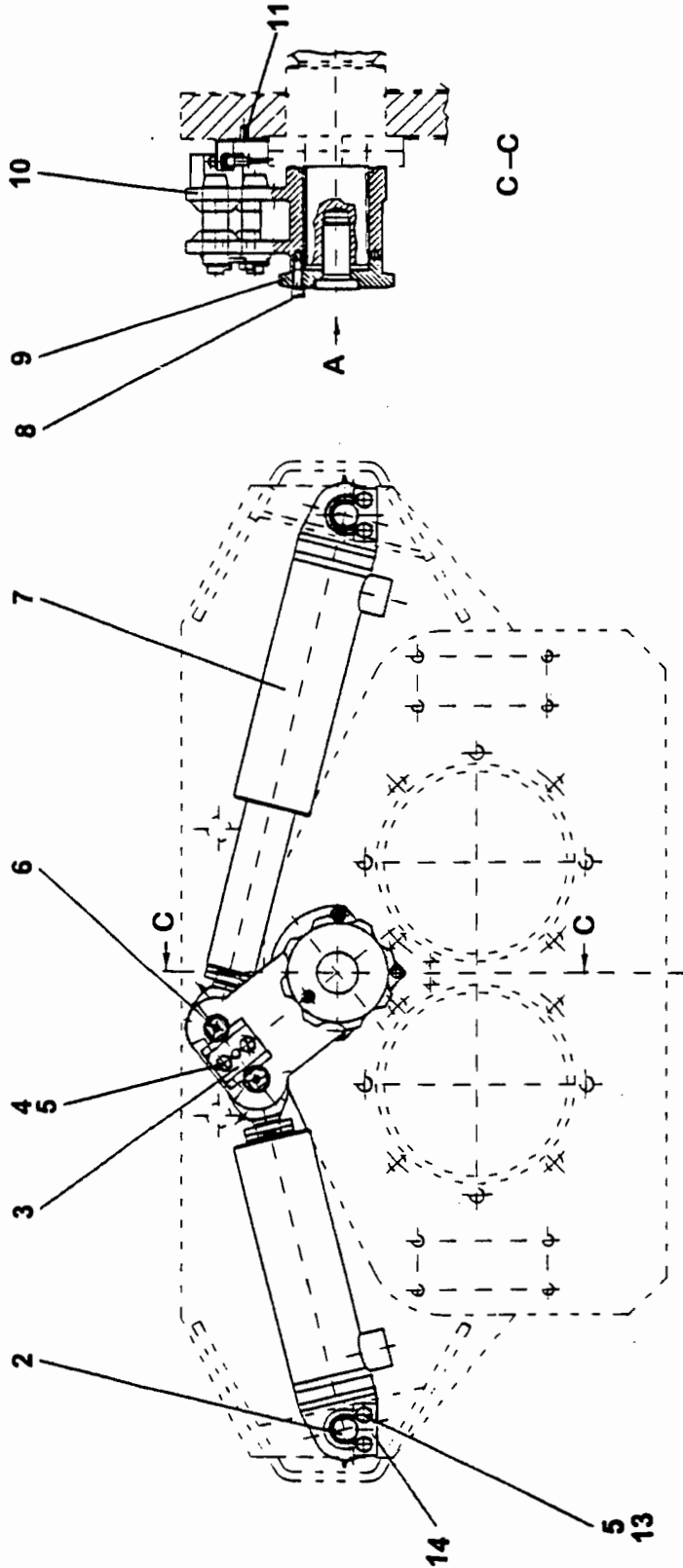





# TILTING DRIVE ASSEMBLY

**XT 36**  
**PARTS**  
GROUP 60  
FIGURE 03  
PAGE 02

ITEM NO.	REED'S PARTS NO.	DESCRIPTION					QTY
		1	2	3	4	5	
-1	B-174030	Assembly, Tilting Drive (See Group 60, Figure 01 for NHA)					Ref
2	B-173066	• Pin, Safety					2
3	B-174083	• Plate, Key					1
4	W-102107	• Screw, M12 Hex					2
5	W-102877	• Washer, A12					8
6	B-173019	• Pin					2
7	W-103363	• Assembly, Tilting Cylinder (See Group 60, Figure 04 for DET)					2
8	B-174035	• Screw, M10 Hex (attaching parts)					1
9	B-174032	• Plate, Tension					1
10	B-174031	• Lever, Tilting					1
11	W-102881	• Pin, Spring Type Straight					1
12	B-174084	• Bracket, Sensor					1
13	W-101001	• Bolt, M12					6
14	B-173067	• Plate, Safety Pin					2

DASH (-) ITEM NOT ILLUSTRATED



# TILTING CYLINDER ASSEMBLY

XT 36  
PARTS  
GROUP 60  
FIGURE 04  
PAGE 01

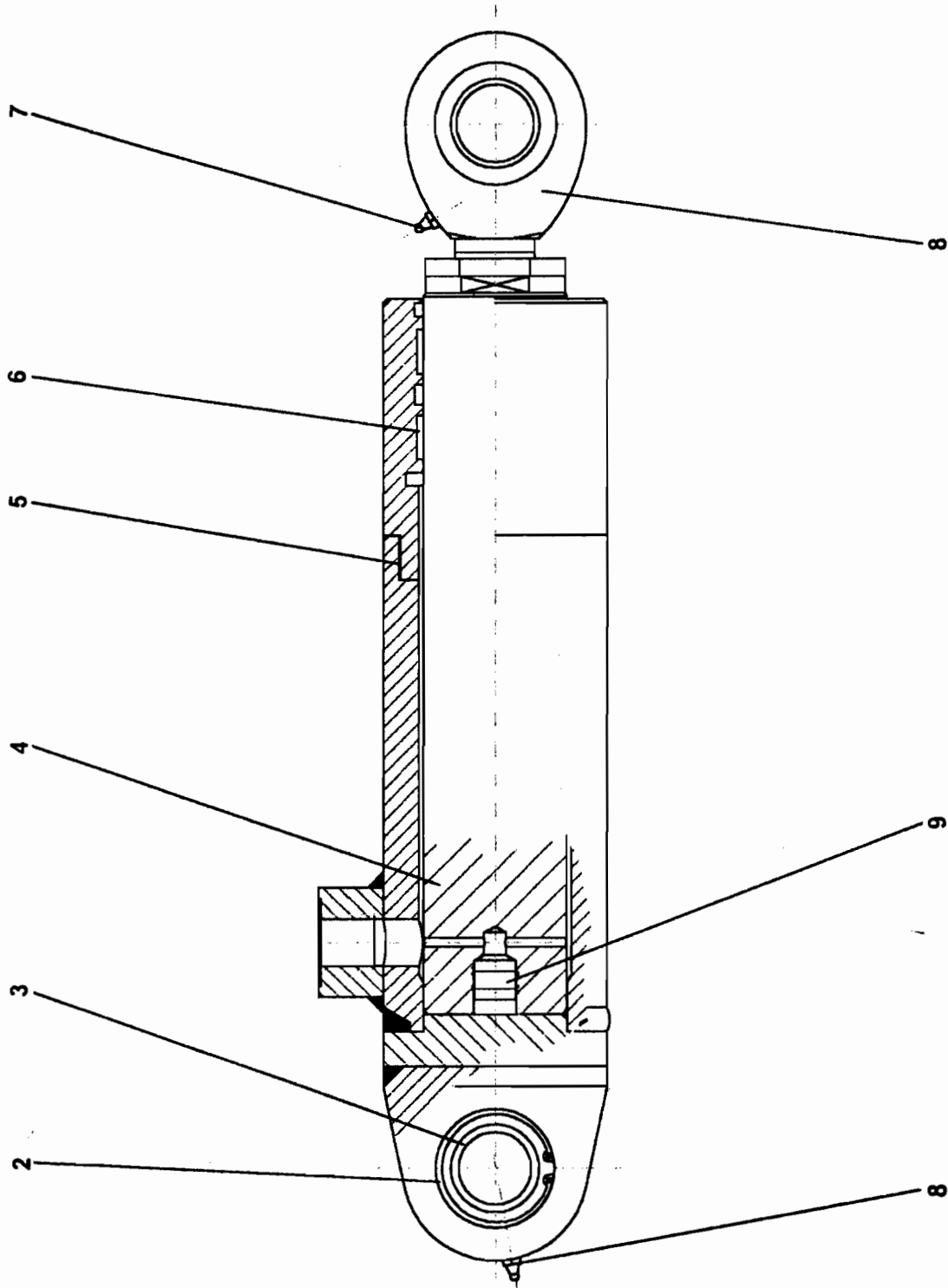

REVISION:



# TILTING CYLINDER ASSEMBLY

**XT 36**  
**PARTS**  
GROUP 60  
FIGURE 04  
PAGE 02

ITEM NO.	REED'S PARTS NO.	DESCRIPTION					QTY
		1	2	3	4	5	
-1	W-103363	Assembly, Tilting Cylinder (See Group 60, Figure 03 for NHA)					Ref
2	W-103626	• Bearing					1
3	W-101973	• Ring, Retaining					1
4	W-104438	• Rod, Piston					1
5	W-104440	• Pipe, Cylinder					1
6	W-103364	• Kit, Seal					1
7	W-100805	• Nipple, Grease					2
8	W-104437	• Valve, Check					1
9	W-104439	• Head, Rod					1

DASH (-) ITEM NOT ILLUSTRATED

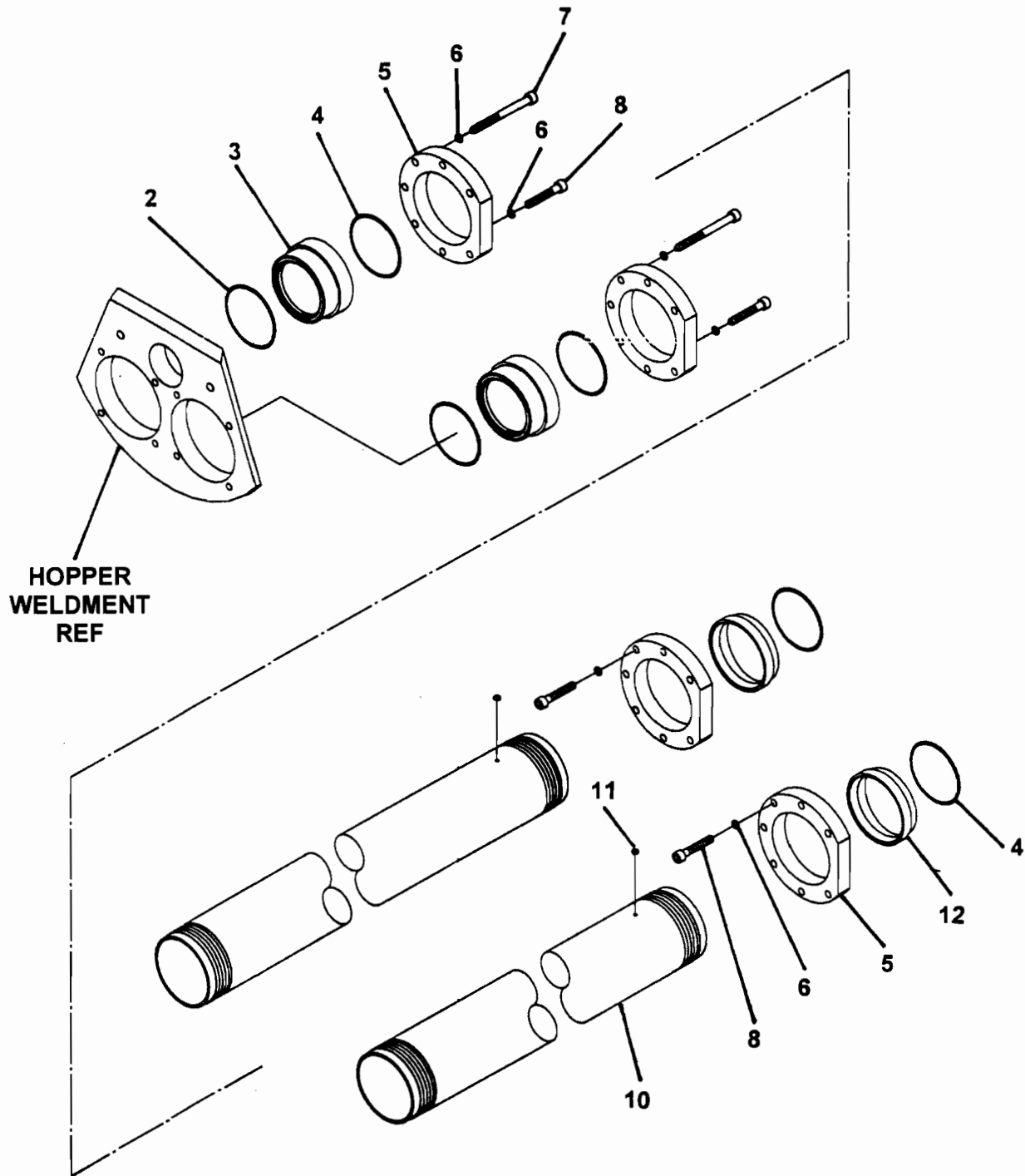



# CONCRETE CYLINDER ASSEMBLY

**XT 36**  
**PARTS**  
GROUP 60  
FIGURE 05  
PAGE 02

ITEM NO.	REED'S PARTS NO.	DESCRIPTION					QTY
		1	2	3	4	5	
-1	B-124017	Assembly, Concrete Cylinder (See Group 60, Figure 01 for NHA)					Ref
2	W-101090	• O-Ring					2
3	B-124015	• Ring, Fitting					2
4	W-102868	• O-Ring					4
5	B-123007	• Flange					4
6	W-100691	• Washer					28
7	W-102885	• Bolt, M20					6
8	W-103970	• Screw, M20					14
-9	W-102845	• Bolt, M20					8
10	B-123011	• Cylinder, Concrete					2
11		• Fitting, Grease					2
12	B-123012	• Ring, Fitting					2

DASH (-) ITEM NOT ILLUSTRATED



# WATER BOX ASSEMBLY

XT 36  
PARTS  
GROUP 60  
FIGURE 06  
PAGE 01

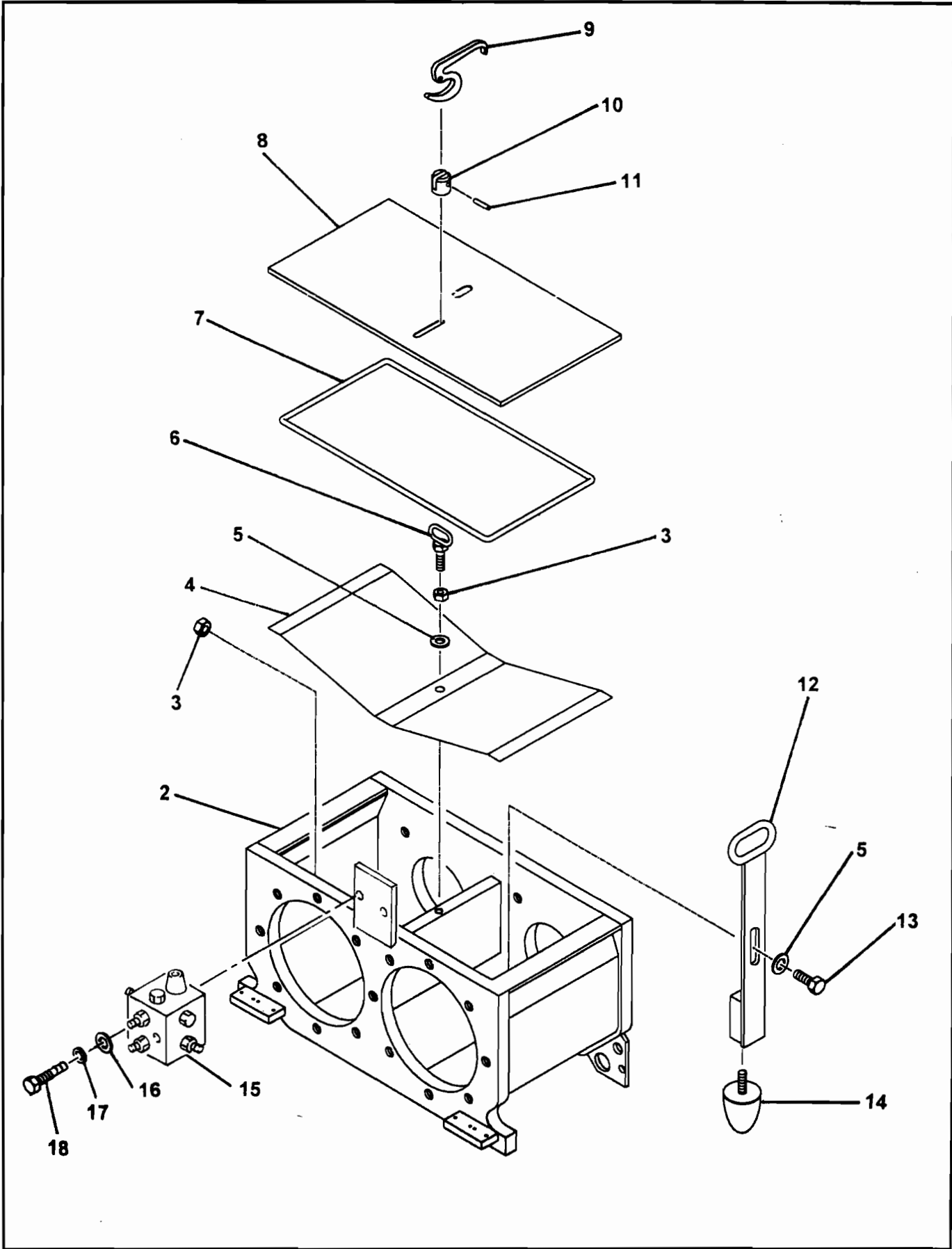

REVISION:



# WATER BOX ASSEMBLY

**XT 36**  
**PARTS**  
GROUP 60  
FIGURE 06  
PAGE 02

ITEM NO.	REED'S PARTS NO.	DESCRIPTION					QTY
		1	2	3	4	5	
-1	B-143030	Assembly, Water Box (See Group 60, Figure 01 for NHA)					Ref
2	B-143031	• Weldment, Water Box					1
3	W-101557	• Nut, M12 Hex					2
4	B-143020	• Cover, Safety					1
5	W-100504	• Washer					2
6	B-143009	• Bolt, M12 Eye					1
7	W-101831	• Seal, Round Cord					1
8	B-143015	• Cover, Water Box					1
9	B-143007	• Lever					1
10		• Head, Eye Bolt					1
11	W-103387	• Pin, Grooved					1
12	B-143011	• Handle					1
13	W-103688	• Bolt, M12 Hex					1
14	W-102712	• Buffer, Rubber					1
15	W-104402	• Block, Lube					1
16		• Washer, Flat (attaching parts)					2
17		• Washer, Lock (attaching parts)					2
18		• Bolt, Hex (attaching parts)					2

DASH (-) ITEM NOT ILLUSTRATED

## HYDRAULIC DRIVE CYLINDER ASSEMBLY

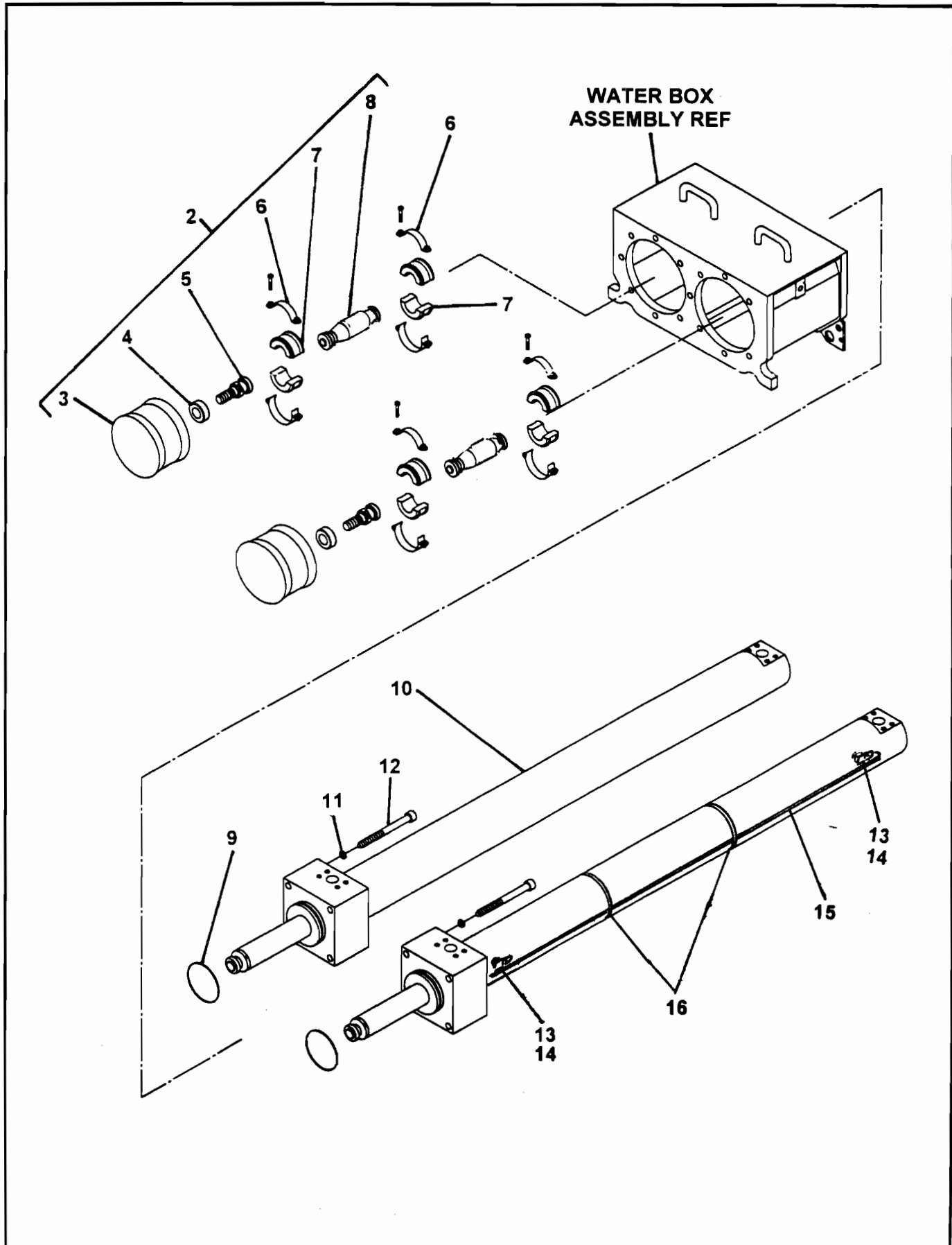





# HYDRAULIC DRIVE CYLINDER ASSEMBLY

**XT 36**  
**PARTS**  
GROUP 60  
FIGURE 07  
PAGE 02

ITEM NO.	REED'S PARTS NO.	DESCRIPTION					QTY
		1	2	3	4	5	
-1	60-06	Assembly, Hydraulic Drive Cylinder (See Group 60, Figure 01 for NHA)					Ref
2	B-133012	• Assembly, Piston Ram					1
3	W-100175	• • Ram, Piston					2
4	W-100934	• • Ring, Fitting					2
5	B-131003	• • Pin, Coupling					2
6	W-101381	• • Clamp, Hose					4
7	B-131004	• • Coupling, Clamp					4
8	B-133003	• • Adapter, Dog Bone					2
9	W-100190	• O-Ring					2
10	B-154030	• Sub-Assembly, Hydraulic Drive Cylinder (See Group 60, Figure 08 for DET)					2
11	W-103070	• Washer (attaching parts)					6
12	W-102846	• Bolt (attaching parts)					6
13	79285	• Guard, Prox Switch					2
14	78416	• Switch, Prox					2
15	78417	• Cable, Prox Switch					2
16		• Tie-Down (attaching parts)					2

DASH (-) ITEM NOT ILLUSTRATED

## HYDRAULIC DRIVE CYLINDER SUB-ASSEMBLY

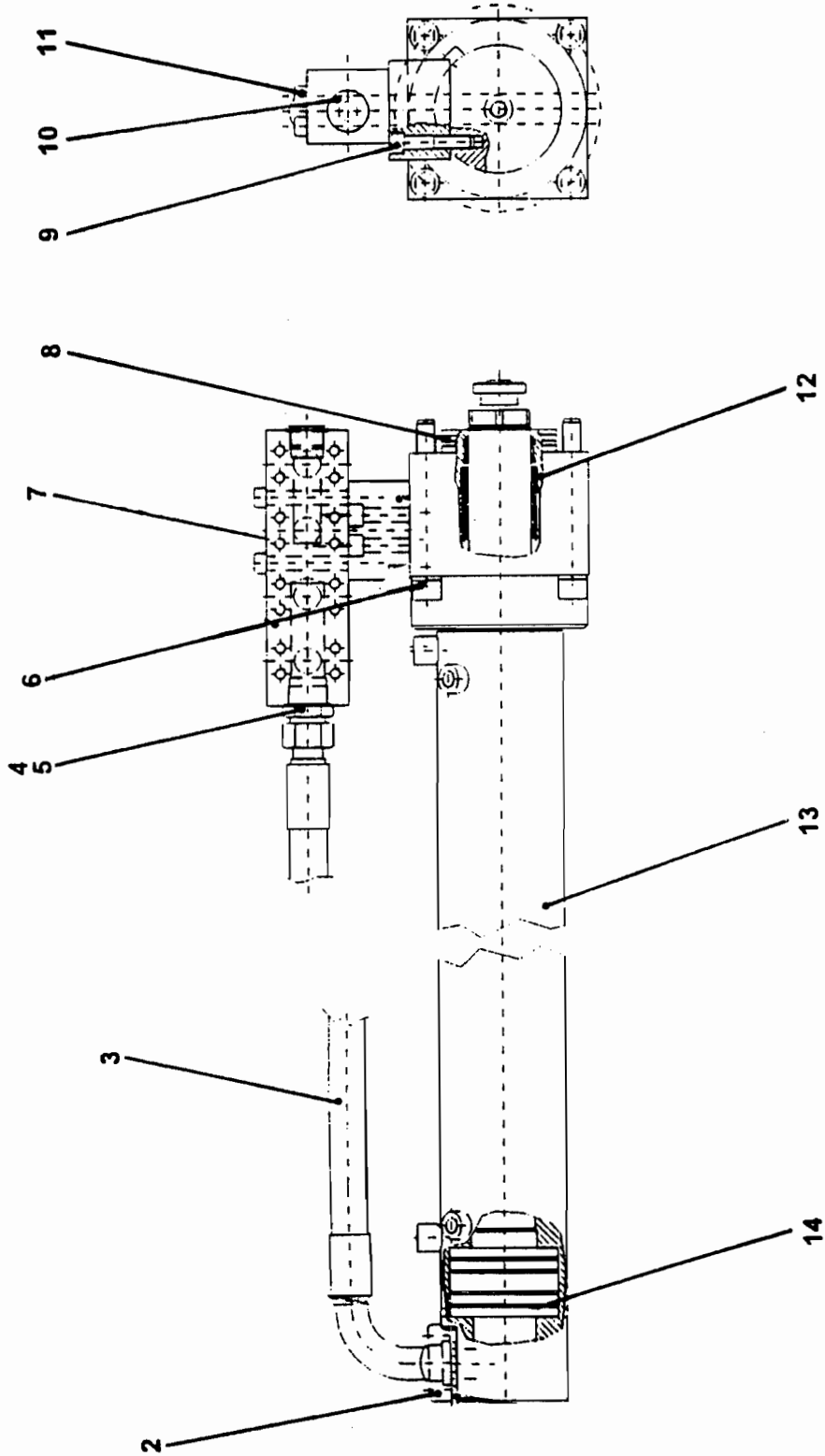

**HYDRAULIC DRIVE  
CYLINDER SUB-ASSEMBLY**

ITEM NO.	REED'S PARTS NO.	DESCRIPTION					QTY
		1	2	3	4	5	
-1	B-154030	Sub-Assembly, Hydraulic Drive Cylinder (See Group 60, Figure 07 for NHA)					Ref
2	W-102305	• Flange (set)					1
3		• Assembly, High Pressure Hose					1
4	W-102846	• Screw, M24					4
5	W-103070	• Washer, Spring					4
6	W-102184	• Coupling, Straight Male Stud					1
7	B-153002	• Box, Hydraulic					1
8	W-100190	• O-Ring					1
9		• Screw, M16					4
10	W-103347	• Screw, Locking					1
11		• Screw, M16					4
12	W-102393	• Set, Seal					1
13	W-102504	• Cylinder, Drive					1
14	W-105049	• Ring, Piston					4
-15	B-153003	• Block, Hydraulic					1
-16	78416	• Sensor, Proximity					2
-17	78417	• Cable, Proximity Sensor					2
-18	79285	• Guard, Proximity Sensor					2
-19		• Valve, Check					2

DASH (-) ITEM NOT ILLUSTRATED



**MODEL XT 36 TRUCK MOUNTED  
CONCRETE BOOM PUMP  
ILLUSTRATED PARTS MANUAL**

**XT 36  
PARTS  
GROUP 60  
FIGURE 09  
PAGE 01**

THIS PAGE INTENTIONALLY LEFT BLANK.

**REED** TRUCK MOUNTED CONCRETE BOOM PUMP MODEL **XT 36** ILLUSTRATED PARTS MANUAL GROUP 70 FRAME AND SUPPORT INSTALLATION CONTAINS THE FOLLOWING FIGURES:

<b>FIGURE 00</b>	TABLE OF CONTENTS
<b>FIGURE 01</b>	FRAME AND SUPPORT INSTALLATION
<b>FIGURE 02</b>	TURRET ASSEMBLY
<b>FIGURE 03</b>	MOTOR AND REDUCTION ASSEMBLY
<b>FIGURE 04</b>	ROTATION UNIT ASSEMBLY
<b>FIGURE 05</b>	PEDESTAL ASSEMBLY
<b>FIGURE 06</b>	FRONT OUTRIGGER GROUP ASSEMBLY
<b>FIGURE 07</b>	REAR OUTRIGGER GROUP ASSEMBLY
<b>FIGURE 08</b>	OUTRIGGER EXTEND CYLINDER ASSEMBLY
<b>FIGURE 09</b>	OUTRIGGER JACK CYLINDER ASSEMBLY
<b>FIGURE 10</b>	SWING OUT CYLINDER ASSEMBLY
<b>FIGURE 11</b>	RIGHT HAND SIDE HOSE REEL ASSEMBLY
<b>FIGURE 12</b>	OUTRIGGER HOLDING VALVE ASSEMBLY

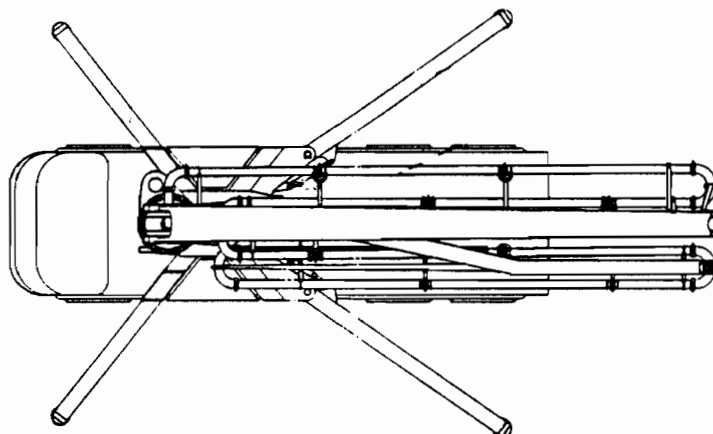
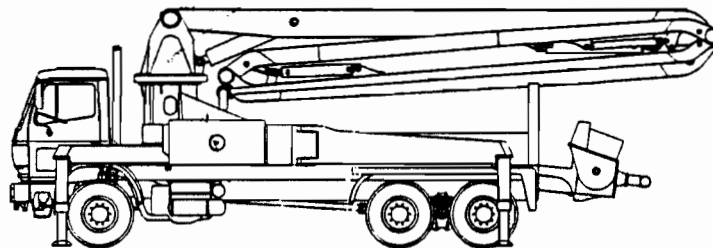



# FRAME AND SUPPORT INSTALLATION

XT 36  
PARTS  
GROUP 70  
FIGURE 01  
PAGE 01

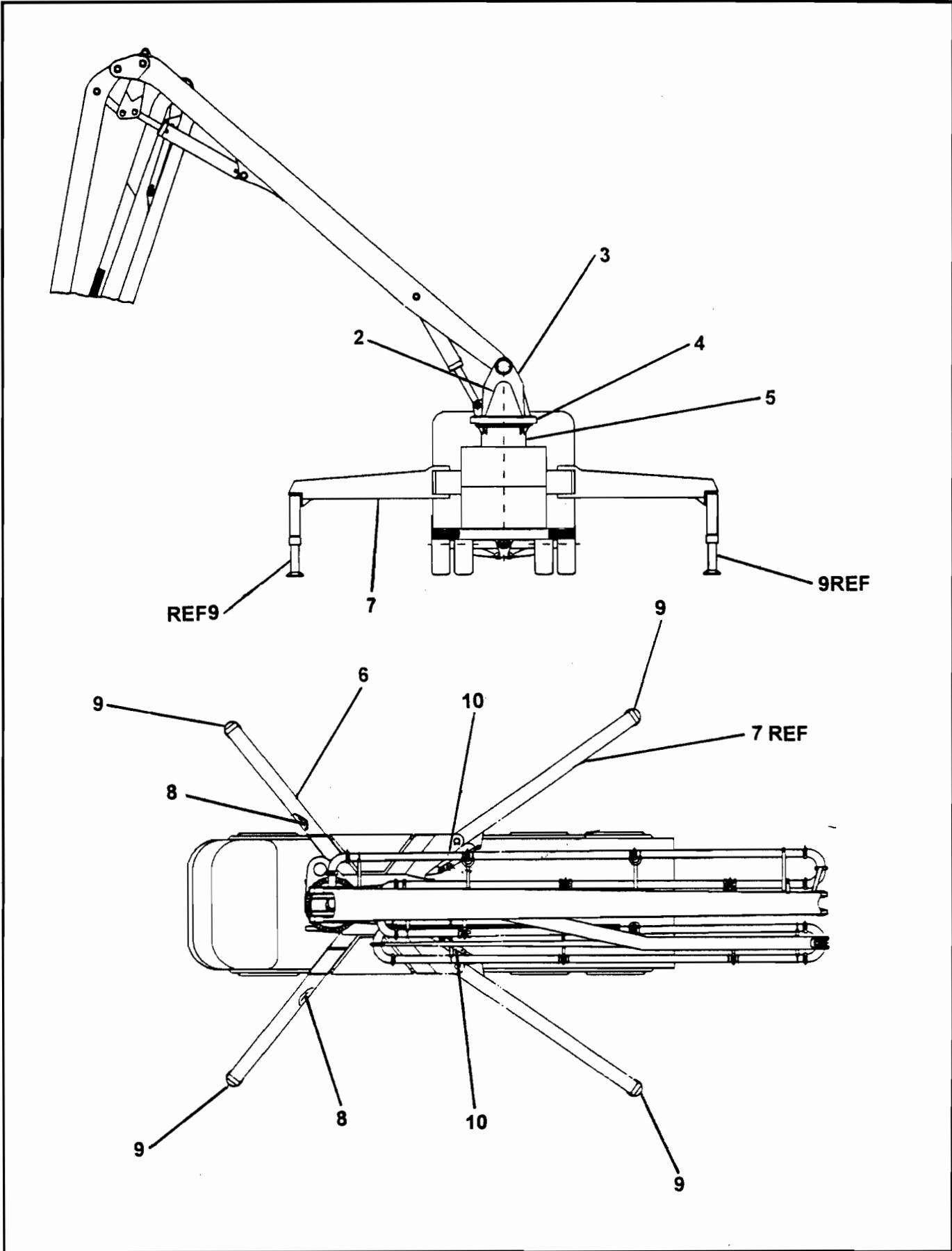

REVISION:

ITEM NO.	REED'S PARTS NO.	DESCRIPTION					QTY
		1	2	3	4	5	
-1	70-01	Installation, Frame And Support (See Group 10, Figure 01 for NHA)					Ref
2	802019	• Assembly, Turret (See Group 70, Figure 02 for DET)					1
3	C-8G1	• Assembly, Motor And Reduction (See Group 70, Figure 03 for DET)					1
4	C-8G2	• Assembly, Rotation Unit (See Group 70, Figure 04 for DET)					1
5	802102	• Assembly, Pedestal (See Group 70, Figure 05 for DET)					1
6	802105	• Assembly, Front Outrigger Group (See Group 70, Figure 06 for DET)					1
7	802106	• Assembly, Rear Outrigger Group (See Group 70, Figure 07 for DET)					1
8	802112	• Assembly, Outrigger Extend Cylinder (See Group 70, Figure 08 for DET)					2
9	802404	• Assembly, Outrigger Jack Cylinder (See Group 70, Figure 09 for DET)					4
10	802113	• Assembly, Rear Swing Out Cylinder (See Group 70, Figure 10 for DET)					2
-11	802130	• Assembly, Right Hand Side Hose Reel (See Group 70, Figure 11 for DET)					1
-12	802144	• Assembly, Outrigger Holding Valve (See Group 70, Figure 12 for DET)					4

DASH (-) ITEM NOT ILLUSTRATED



# TURRET ASSEMBLY

XT 36  
PARTS  
GROUP 70  
FIGURE 02  
PAGE 01

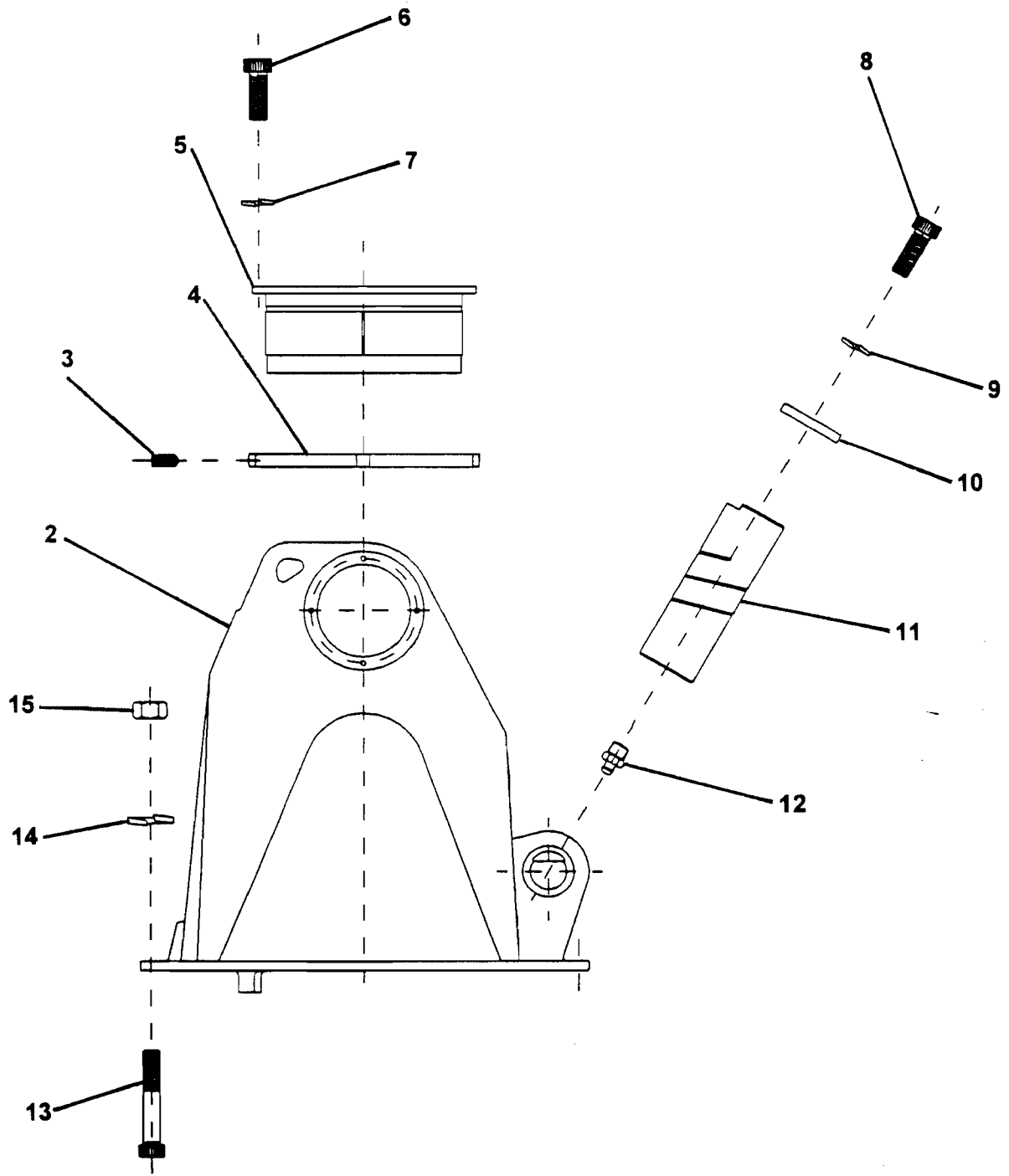
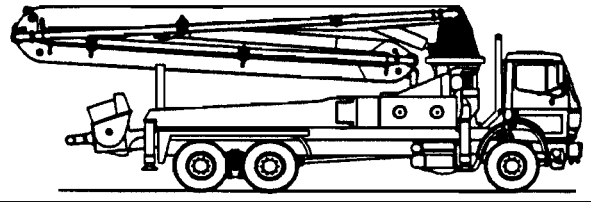
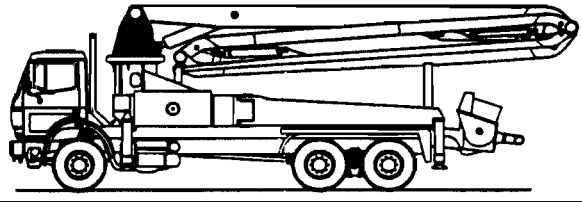

REVISION:



ITEM NO.	REED'S PARTS NO.	DESCRIPTION					QTY
		1	2	3	4	5	
-1	802019	Assembly, Turret (See Group 70, Figure 01 for NHA)					Ref
2	802072	• Weldment, Turret					1
3	C-VG122.061010	• Screw					4
4	802039	• Ring, First Boom Pin Threaded					2
5	802020	• Pin, First Boom Hollow					2
6	C-VC110.142040	• Screw					8
7	C-UE110.14	• Washer, Elastic					8
8	C-VC110.101525	• Screw					1
9	C-UE110.10	• Washer, Elastic					1
10	802045	• Washer, Pin					1
11	802021	• Pin, Pivot					1
12	C-VI131.1010	• Nipple, Grease					1
13	C-VC130.2225C6	• Screw					48
14	C-UE110.22	• Washer					48
15	C-VD113.2225	• Nut					48

DASH (-) ITEM NOT ILLUSTRATED

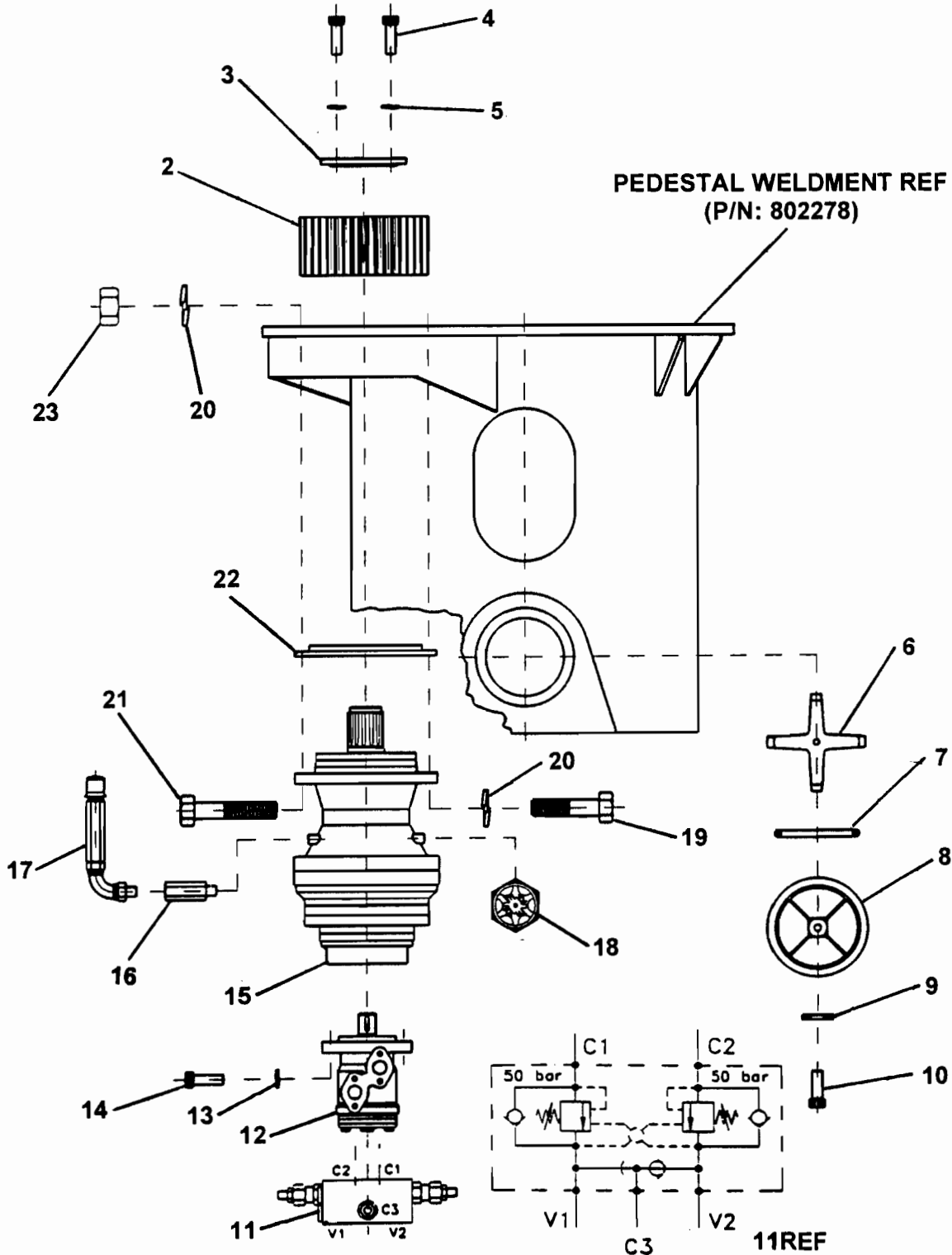
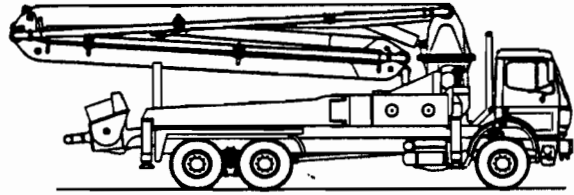
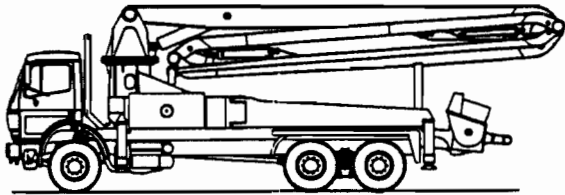



# MOTOR AND REDUCTION ASSEMBLY

**XT 36**  
**PARTS**  
GROUP 70  
FIGURE 03  
PAGE 02

ITEM NO.	REED'S PARTS NO.	DESCRIPTION	QTY
-1	C-8G1	Assembly, Motor And Reduction (See Group 70, Figure 01 for NHA)	Ref
2	802074	• Gear, Pinion	1
3	802078	• Washer, Pinion	1
4	C-VC110.101530	• Screw	3
5	C-UE110.10	• Washer, Elastic	3
6	802085	• Support, Tank Cover Star	1
7	802086	• O-Ring, Tank Cover	1
8	802084	• Cover, Tank	1
9	802087	• Washer, Tank Cover Sealing	1
10	C-VC110.162040	• Screw	1
11	802077	• Valve, Over Center Rotation	1
12	802076	• Assembly, Rotation Hydraulic Motor	1
13	C-UE110	• Washer, Elastic	4
14	C-VC110	• Screw	4
15	802075	• Reducer, Rotation Gear	1
16	C-NP020.040MF	• Fitting	1
17	802082	• Breather	1
18	802083	• Gage, Oil Level	1
19	C-VE110.162055	• Screw	3
20	C-UE110.16	• Washer, Elastic	10
21	C-VE110.162075	• Screw	3
22	802079	• Flange, Pinion Adjustment	1
23	C-VD111.1620	• Nut	7

DASH (-) ITEM NOT ILLUSTRATED



# ROTATION UNIT ASSEMBLY

XT 36  
PARTS  
GROUP 70  
FIGURE 04  
PAGE 01

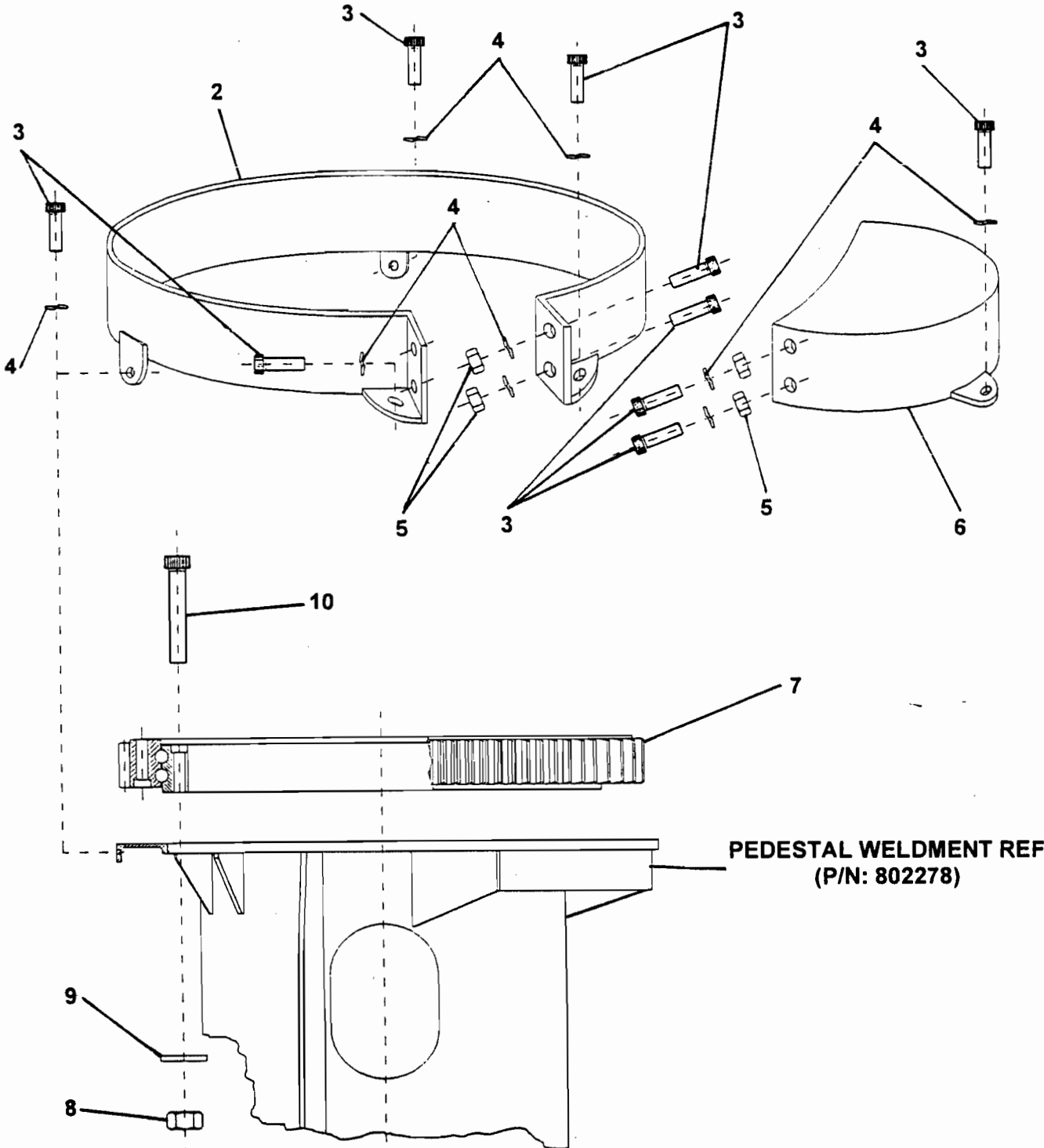
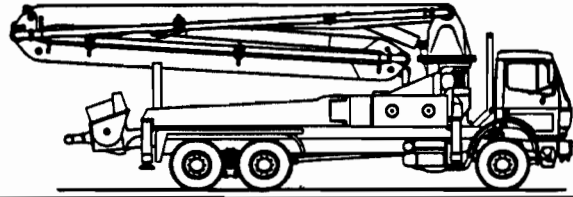
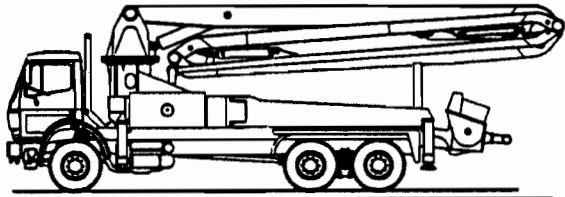



# ROTATION UNIT ASSEMBLY

**XT 36**  
**PARTS**  
GROUP 70  
FIGURE 04  
PAGE 02

ITEM NO.	REED'S PARTS NO.	DESCRIPTION					QTY
		1	2	3	4	5	
-1	C-8G2	Assembly, Rotation Unit (See Group 70, Figure 01 for NHA)					Ref
2	802080	• Cover, Rotation Bearing					1
3	C-VC110.081525	• Screw					9
4	C-UE110.08	• Washer, Elastic (attaching parts)					9
5	C-VD111.0812	• Nut					4
6	802081	• Cover, Rotation Pinion					1
7	802073	• Bearing, Rotation					1
8	C-VD113.2225	• Nut (attaching parts)					48
9	C-UP110.22	• Washer (attaching parts)					48
10	C-VC130.2225C6	• Screw (attaching parts)					48

DASH (-) ITEM NOT ILLUSTRATED

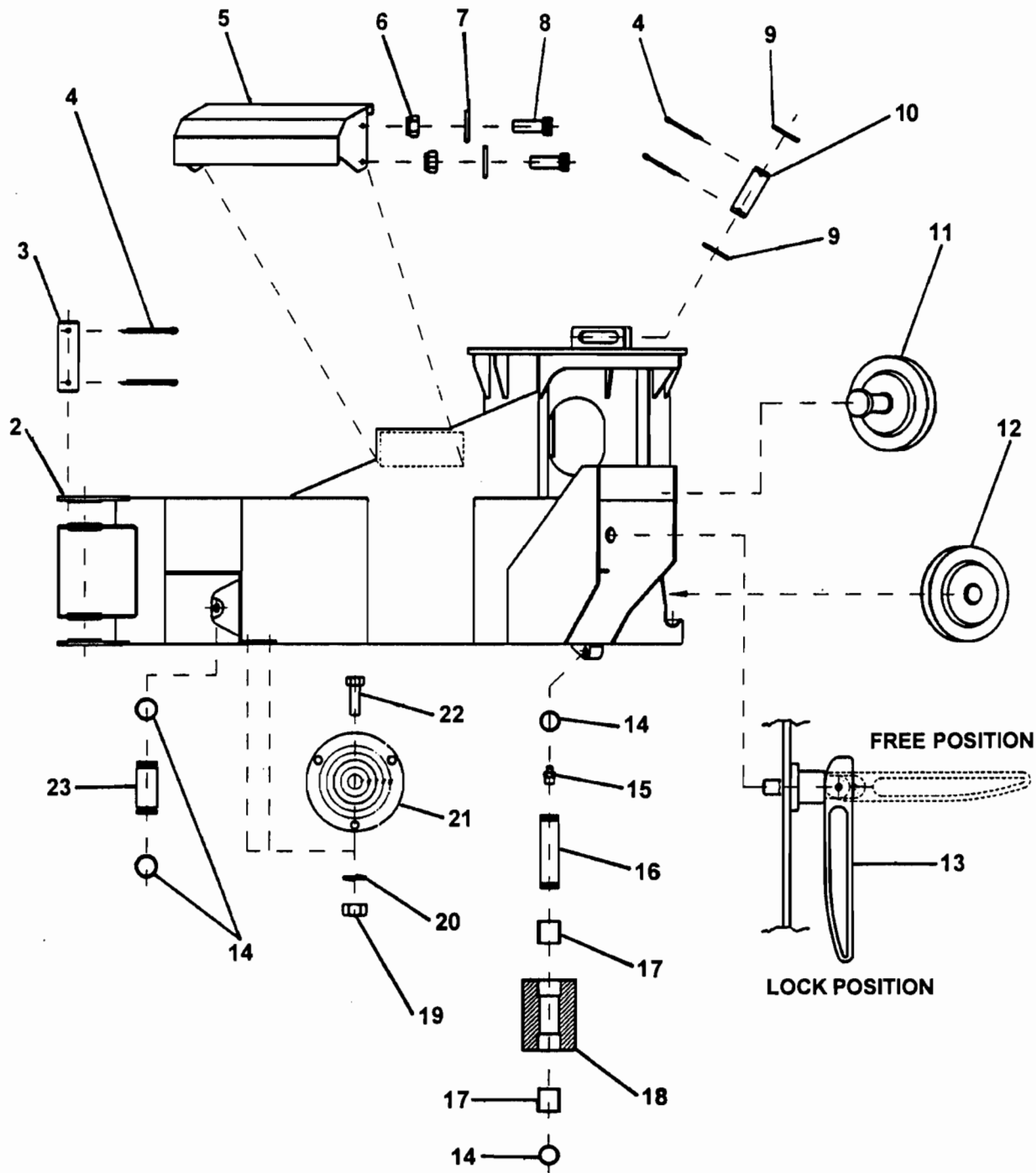



# PEDESTAL ASSEMBLY

**XT 36**  
**PARTS**  
GROUP 70  
FIGURE 05  
PAGE 02

ITEM NO.	REED'S PARTS NO.	DESCRIPTION					QTY
		1	2	3	4	5	
-1	802102	Assembly, Pedestal (See Group 70, Figure 01 for NHA)					Ref
2	802278	• Weldment, Pedestal					1
3	802115	• Pin, Swing Out Cylinder					6
4	C-VS110.08070	• Pin, Split					14
5	C-1H106	• Cover, Distributor					1
6	C-VD111.0812	• Nut, Self Locking					4
7	C-UP110.08	• Washer					4
8	C-VC110.081225	• Screw					4
9	802124	• Washer, Rotation Stop					2
10	802114	• Pin, Rotation Stop					1
11	802130	• Assembly, Right Hand Side Hose Reel (See Group 70, Figure 11 for DET)					1
12	802129	• Reel, Left Hand Side Hose					1
13	802131	• Lock, Outtrigger					1
14	C-AA110.025	• Ring, Clamping					1
15	C-VI131.0608	• Nipple, Grease					2
16	802118	• Pin, Bottom Extended Roller					2
17	802125	• Bearing					4
18	802121	• Roller, Bottom Extended					2
19	C-VD111.0407	• Nut					3
20		• Screw					
21	C-LL401	• Level					1
22	C-VS110.040715	• Pin, Split					3
23	802116	• Pin, Extend Cylinder					2

DASH (-) ITEM NOT ILLUSTRATED



# FRONT OUTRIGGER GROUP ASSEMBLY

XT 36  
PARTS  
GROUP 70  
FIGURE 06  
PAGE 01

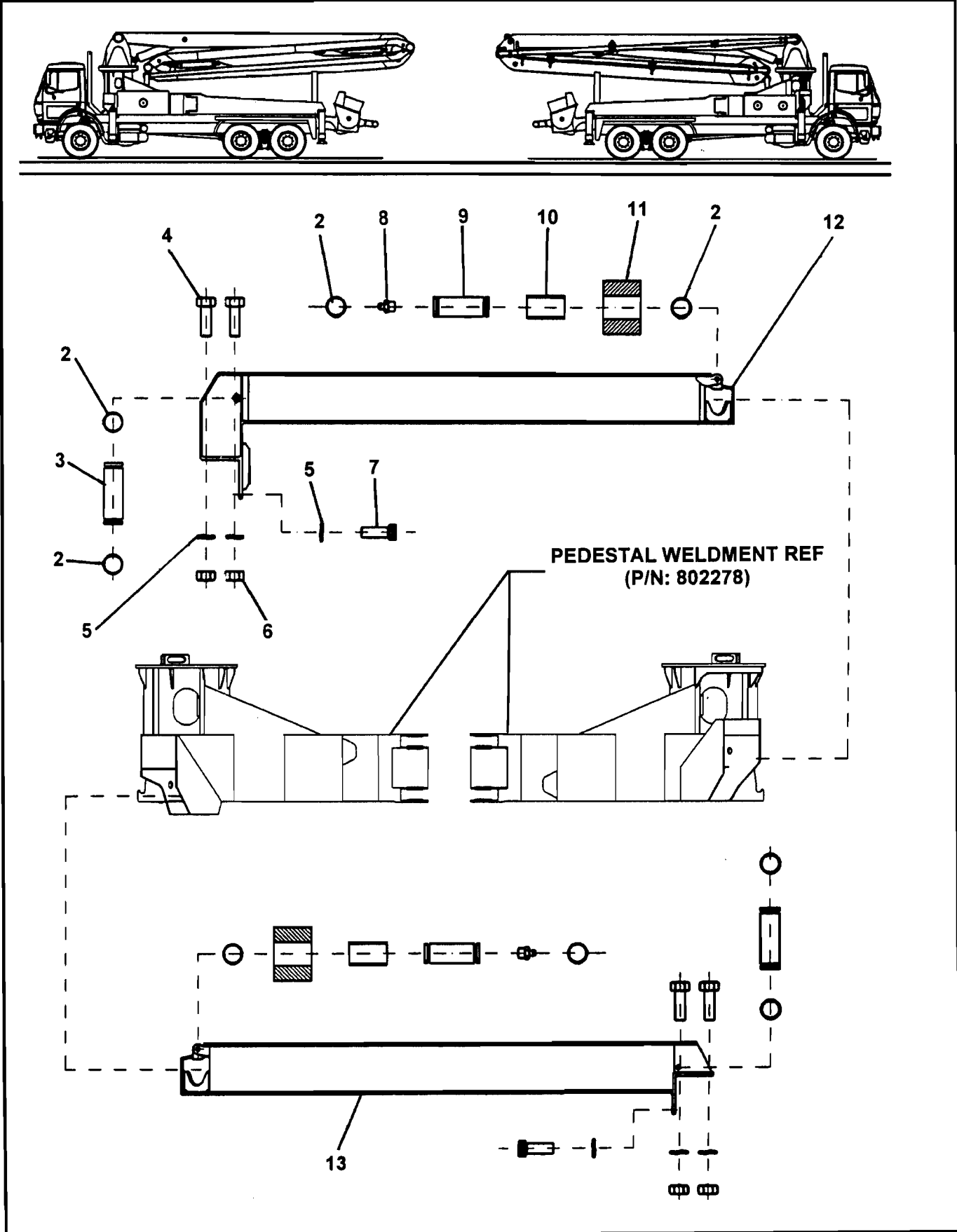





# FRONT OUTRIGGER GROUP ASSEMBLY

**XT 36**  
**PARTS**  
GROUP 70  
FIGURE 06  
PAGE 02

ITEM NO.	REED'S PARTS NO.	1 2 3 4 5	DESCRIPTION	QTY
-1	802105		Assembly, Front Outrigger Group (See Group 70, Figure 01 for NHA)	Ref
2	C-AA110.025	•	Ring, Clamping	8
3	802116	•	Pin, Extend Cylinder	2
4	C-VE110.222580	•	Screw	8
5	C-UE110.22	•	Washer, Elastic	12
6	C-VD111.2225	•	Nut	8
7	C-VC110.222550	•	Screw	4
8	C-VI131.1010	•	Nipple, Grease	2
9	802119	•	Pin, Top Extend Roller	2
10	802126	•	Bearing	2
11	802122	•	Roller, Top Extend Outrigger	2
12	802107	•	Weldment, Right Front Outrigger	1
13	802108	•	Weldment, Left Front Outrigger	1

DASH (-) ITEM NOT ILLUSTRATED

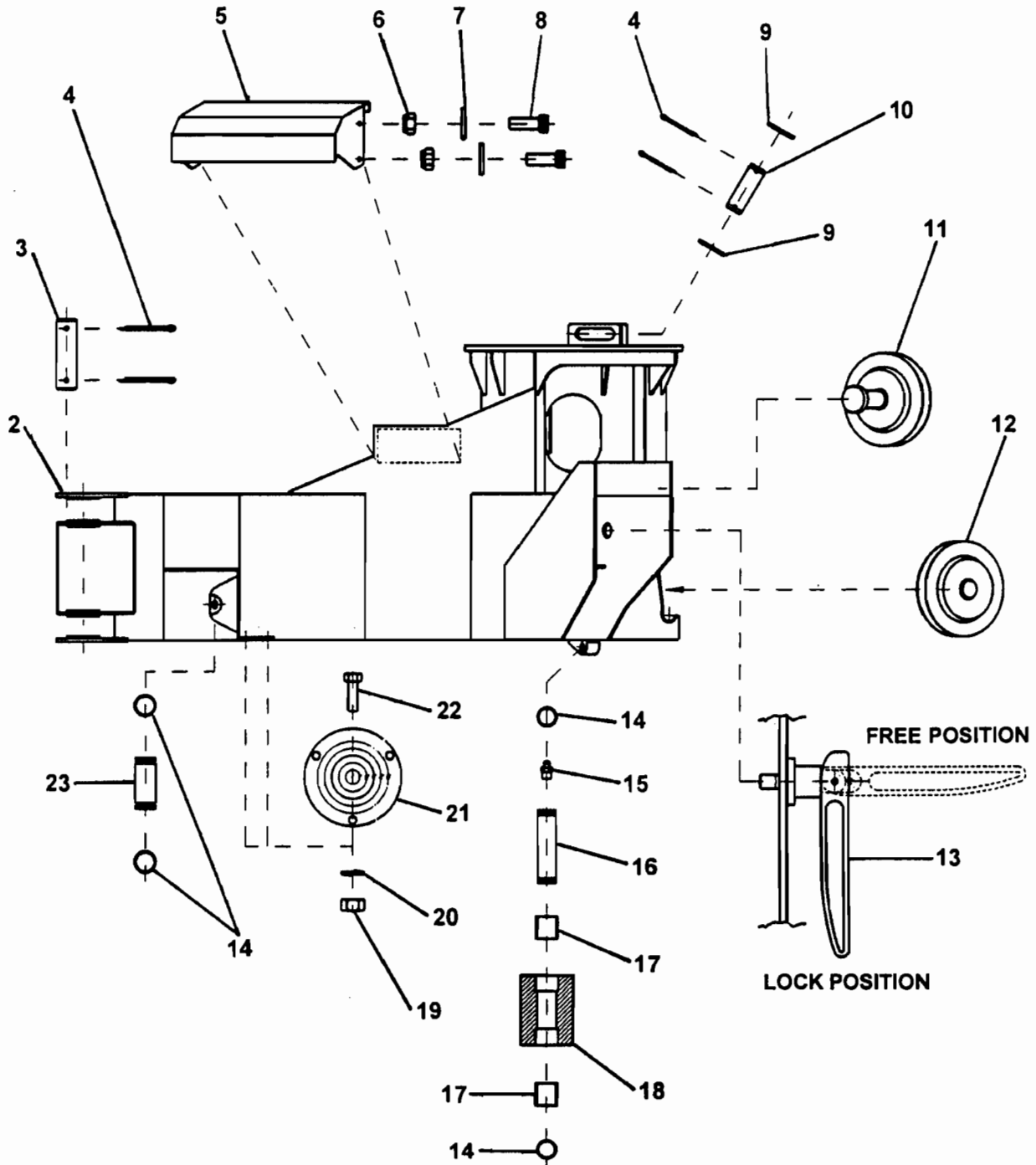
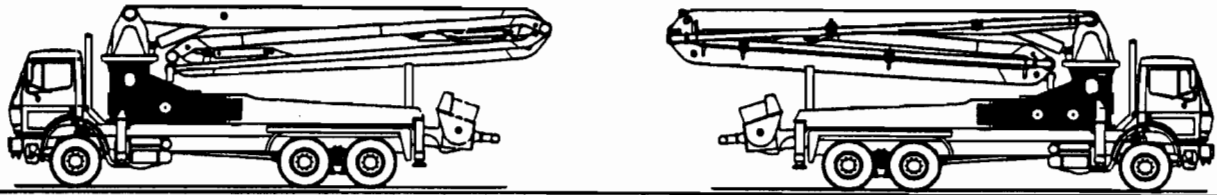



# REAR OUTRIGGER GROUP ASSEMBLY

**XT 36**  
**PARTS**  
GROUP 70  
FIGURE 07  
PAGE 02

ITEM NO.	REED'S PARTS NO.	DESCRIPTION					QTY
		1	2	3	4	5	
-1	802106	Assembly, Rear Outrigger Group (See Group 70, Figure 01 for NHA)					Ref
2	802120	• Pin, Rear Outrigger					4
3	C-VI131.1010	• Nipple, Grease					2
4	802123	• Plate, Outrigger Pin Retainer					4
5	C-UE110.12	• Washer, Elastic					8
6	C-VC110.121730	• Screw					8
7	C-VC110.222550	• Screw					4
8	C-UE110.22	• Washer, Elastic					12
9	C-VD111.2225	• Nut					12
10	C-VE110.222580	• Screw					8
11	802115	• Pin, Swing Out Cylinder					2
12	C-VS110.08070	• Pin, Split					4
13	802127	• Bearing					4
14	802110	• Weldment, Left Rear Outrigger					1
15	802109	• Weldment, Right Rear Outrigger					1
16	C-VC110.081225	• Screw					6
17	C-UP110.08	• Washer					6
18	C-VD221.0812	• Nut, Self Locking					6
19	C-VC110.101530	• Screw					3
20	C-UE110.10	• Washer, Elastic					3
21	C-UG317.30100	• Block, Silent					3

DASH (-) ITEM NOT ILLUSTRATED

## OUTRIGGER EXTEND CYLINDER ASSEMBLY

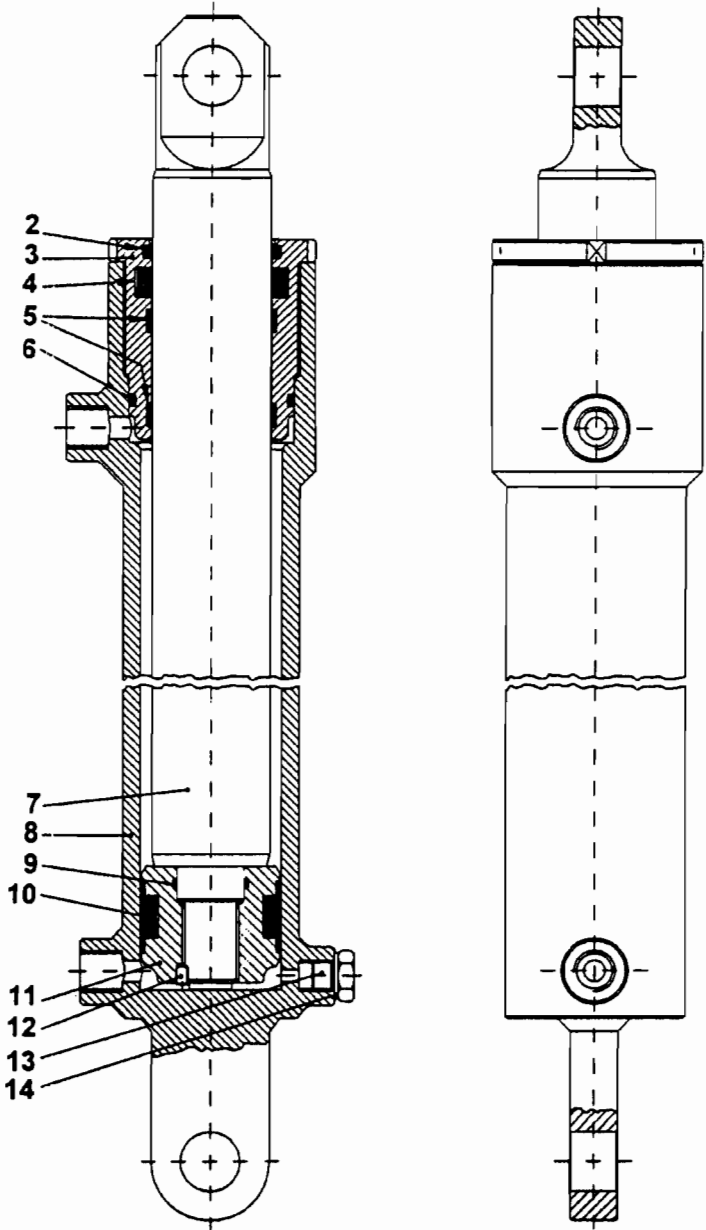
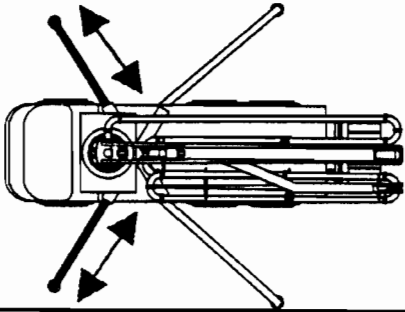



# OUTRIGGER EXTEND CYLINDER ASSEMBLY

**XT 36**  
**PARTS**  
GROUP 70  
FIGURE 08  
PAGE 02

ITEM NO.	REED'S PARTS NO.	DESCRIPTION					QTY
		1	2	3	4	5	
-1	802112	Assembly, Outrigger Extend Cylinder (See Group 70, Figure 01 for NHA)					Ref
2	C-BR310.050	• Gasket, Seal					1
3	C-8K401	• Head, Slide Rod					1
4	C-BT110.050	• Gasket, Seal					1
5	C-AG122.050	• Ring, Slide Rod					2
6	C-AO120.230	• Ring, Sealing					1
7	C-8K407	• Rod					1
8	C-8K402	• Cylinder					1
9	C-AO120.121	• Ring, Sealing					1
10	C-BS23236173	• Gasket, Seal					1
11	C-4K412	• Piston					1
12	C-VG121.061008	• Screw					1
13	DT101	• Plug, Drain					1
14	UP400.13	• Washer, Copper					1

DASH (-) ITEM NOT ILLUSTRATED

## OUTRIGGER JACK CYLINDER ASSEMBLY

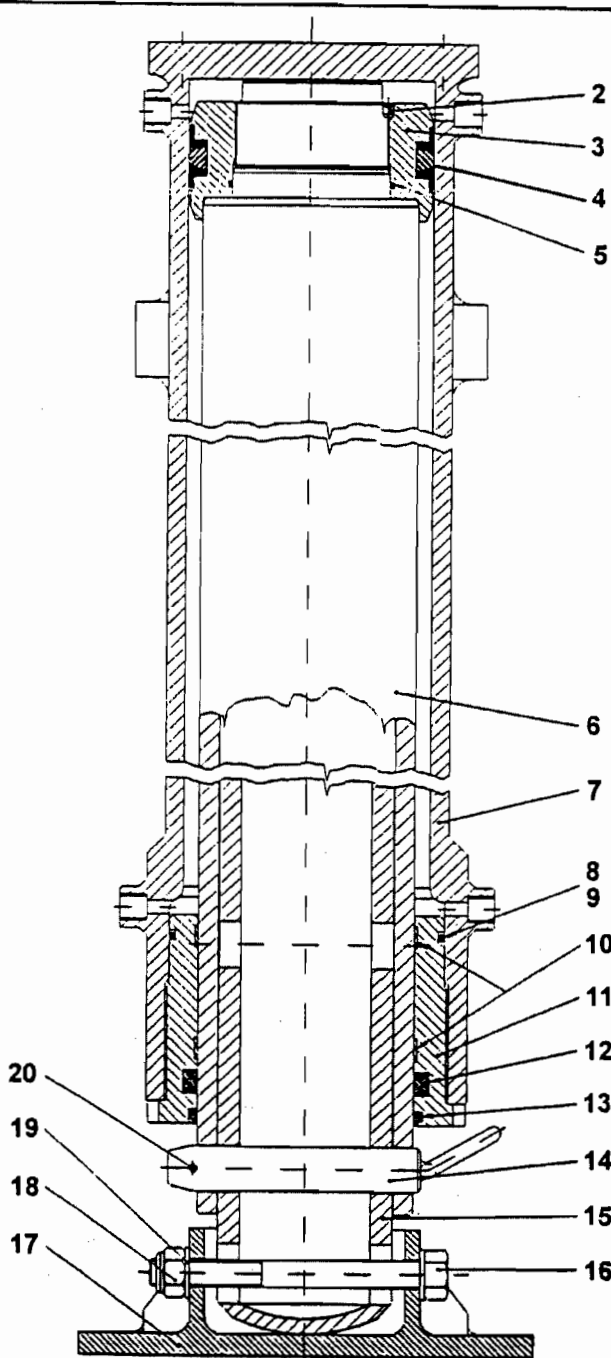
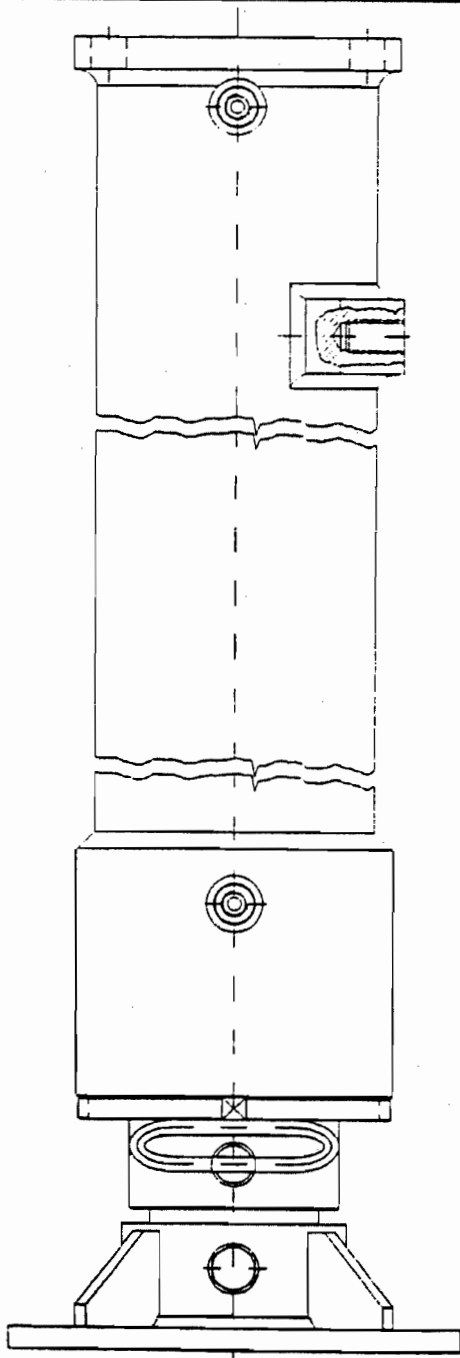
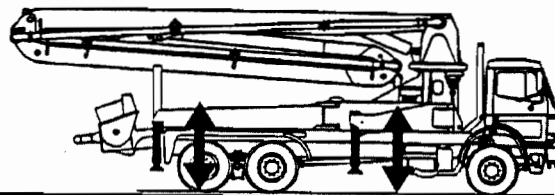
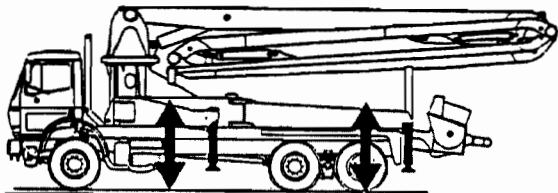



# OUTRIGGER JACK CYLINDER ASSEMBLY

**XT 36**  
**PARTS**  
GROUP 70  
FIGURE 09  
PAGE 02

ITEM NO.	REED'S PARTS NO.	DESCRIPTION					QTY
		1	2	3	4	5	
-1	802404	Assembly, Outrigger Jack Cylinder (See Group 70, Figure 01 for NHA)					Ref
2	C-VG122.081010	• Screw					1
3	C-3K512	• Piston					1
4	C-BS23629531	• Gasket, Seal					1
5	C-AO102.242	• Gasket, Seal					1
6	C-1L507	• Rod					1
7	C-3L502B	• Cylinder					1
8	C-AO120.364	• Gasket, Seal					1
9	C-AP110.364	• Gasket, Seal					1
10	C-AG123.140	• Ring, Slide Rod					2
11	C-3K501	• Head, Slide Rod					1
12	C-BT110.140	• Gasket, Seal					1
13	C-BR310.140	• Gasket, Seal					1
14	C-1L520	• Pin, Check					1
15	C-1L517	• Rod, Manually Operated					1
16	C-VE110.1825C8	• Screw, Foot					1
17	C-6K519	• Foot					1
18	C-VD221.1825	• Nut, Self Locking					1
19	C-UP110.18	• Washer, Elastic					2
20	C-VS110.06040	• Pin, Split					1

DASH (-) ITEM NOT ILLUSTRATED

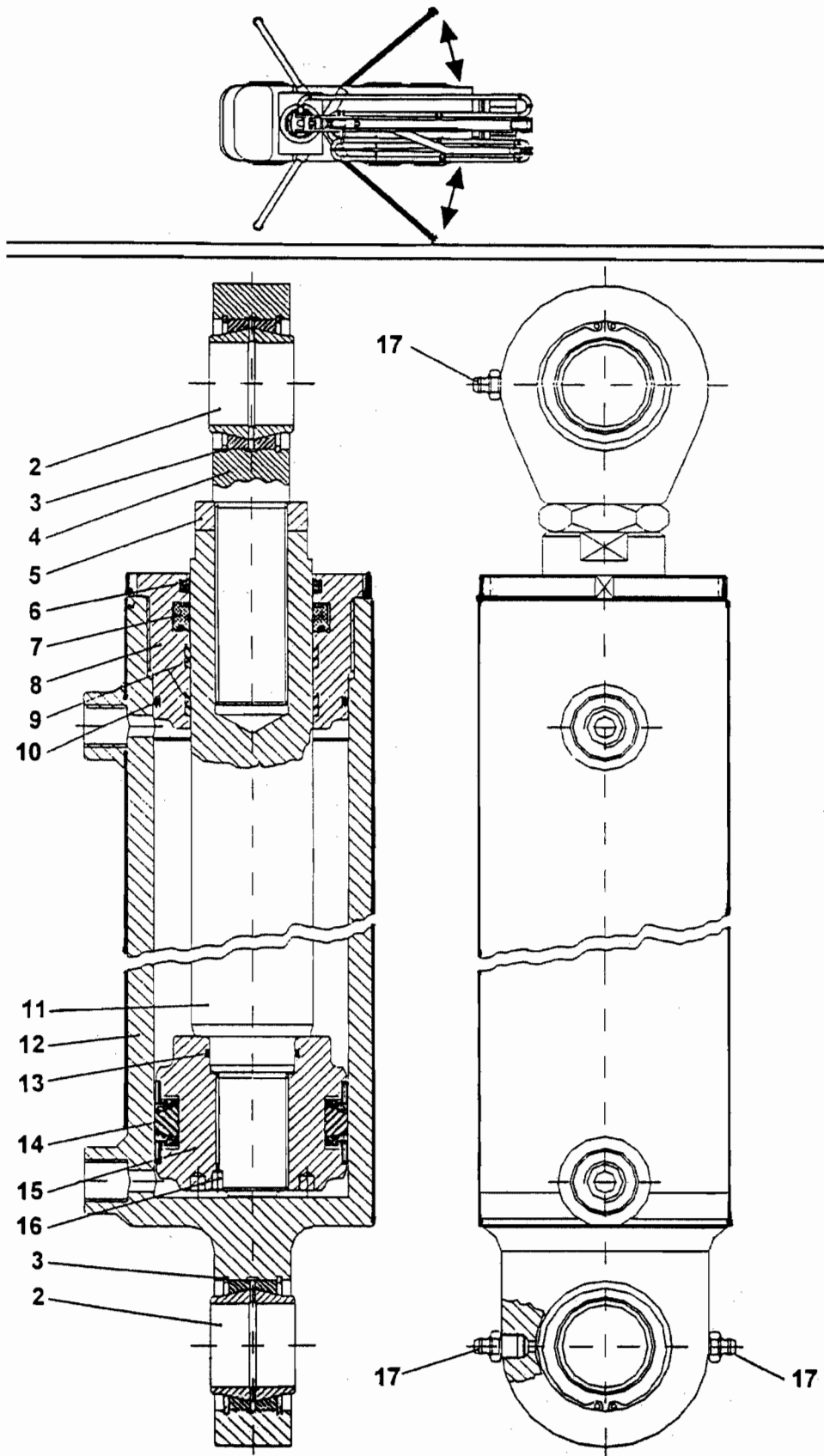

REVISION:





# SWING OUT CYLINDER ASSEMBLY

**XT 36**  
**PARTS**  
GROUP 70  
FIGURE 10  
PAGE 02

ITEM NO.	REED'S PARTS NO.	DESCRIPTION					QTY
		1	2	3	4	5	
-1 -	802113	Assembly, Swing Out Cylinder (See Group 70, Figure 01 for NHA)					Ref
2	C-CT223.035	• Joint, Ball					2
3	C-AA120.055	• Ring, Clamping					4
4	C-8M308	• Cap, Rod					1
5	C-3M325	• Nut					1
6	C-BR210.196228	• Gasket, Seal					1
7	C-BT110.050	• Gasket, Seal					1
8	C-3M301	• Head, Slide Rod					1
9	C-AG122.050	• Ring, Slide Rod					2
10	C-AO420.4287	• Ring, Sealing					1
11	C-8M307	• Rod					1
12	C-8M302	• Cylinder					1
13	C-AO120.126	• Ring, Sealing					1
14	C-BS23314236	• Gasket, Seal					1
15	C-1K312	• Piston					1
16	C-VG122.061008	• Screw					1
17	C-VI131.1010	• Nipple, Grease					3

DASH (-) ITEM NOT ILLUSTRATED



# RIGHT HAND SIDE HOSE REEL ASSEMBLY

XT 36  
PARTS  
GROUP 70  
FIGURE 11  
PAGE 01

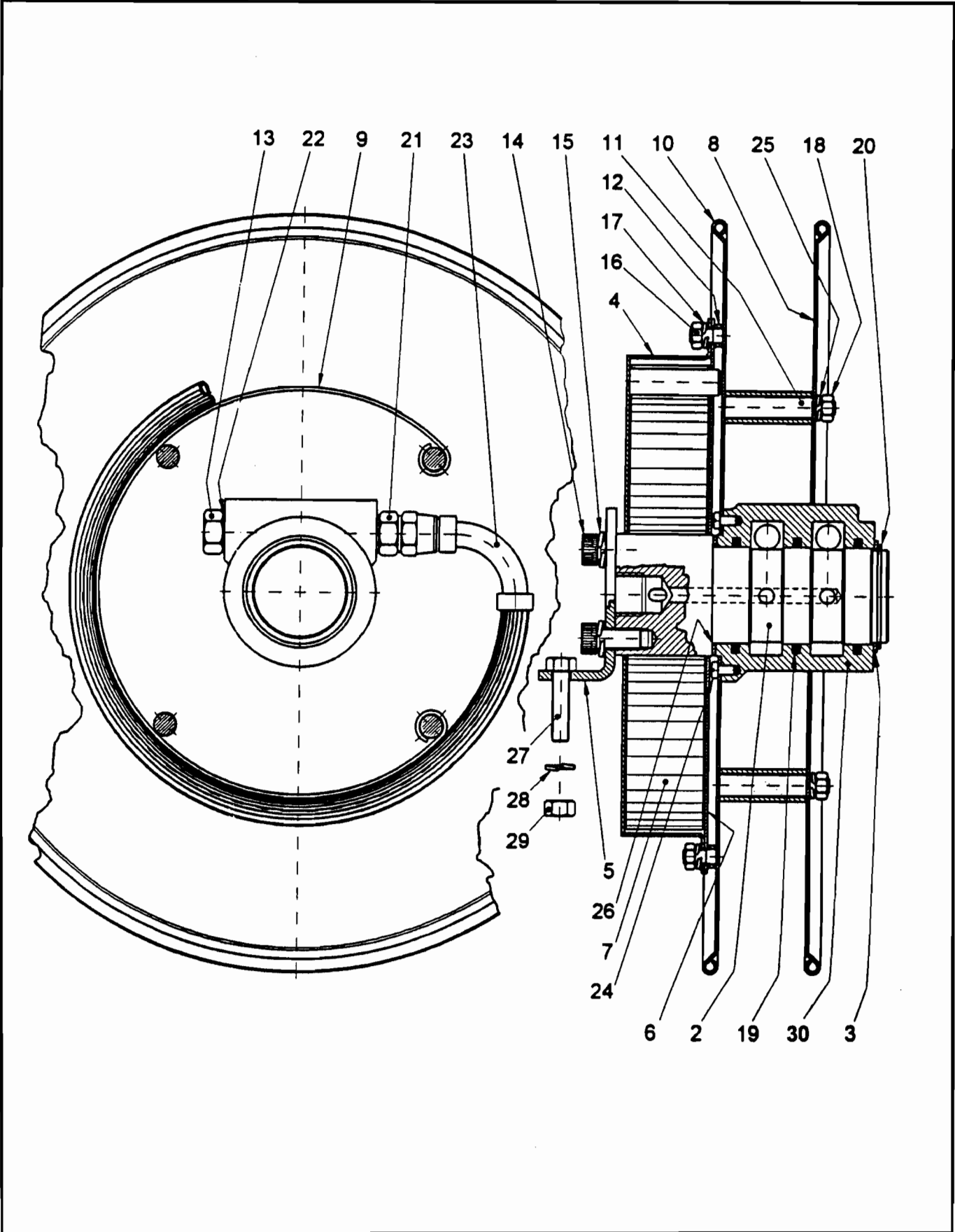

REVISION:

**REED****RIGHT HAND SIDE  
HOSE REEL ASSEMBLY****XT 36  
PARTS  
GROUP 70  
FIGURE 11  
PAGE 02**

ITEM NO.	REED'S PARTS NO.	DESCRIPTION					QTY
		1	2	3	4	5	
-1	802130	Assembly, Right Hand Side Hose Reel (See Group 70, Figure 01 for NHA)					Ref
2	C-RA102.02	• Shaft					1
3	C-RA102.03	• Spacer					1
4	C-RA102.04	• Cap, Spring					1
5	C-RA102.05	• Bracket					1
6	C-RA102.06	• Separator, Spring					1
7	C-RA102.07	• Spring					1
8	C-RA102.08	• Plate, Side					1
9	C-RA102.09	• Band, Coiling					1
10	C-RA102.10	• Plate, Side Spring					1
11	C-RA102.11	• Tie-Rod					4
12	C-RA102.12	• Spacer, For Separator					4
13	C-RA102.13	• Plug					2
14	C-RA102.14	• Screw					2
15	C-RA102.15	• Washer					2
16	C-RA102.16	• Nut					4
17	C-RA102.17	• Washer					4
18	C-RA102.18	• Nut					4
19	C-RA102.19	• Ring, Sealing					3
20	C-RA102.20	• Ring, Clamping					1
21	C-RA102.21	• Fitting					2
22	C-RA102.22	• Washer, Copper					4
23		• Hose, Flexible					1
24	C-RA102.24	• Screw					4
25	C-RA102.25	• Washer					4
26	C-RA102.26	• Spacer					1
27	C-RA102.27	• Screw					2
28	C-RA102.28	• Washer, Elastic					2
29	C-RA102.29	• Nut					2
30	C-RA102.01	• Bearing					1

DASH (-) ITEM NOT ILLUSTRATED

## OUTRIGGER HOLDING VALVE ASSEMBLY

XT 36  
PARTS  
GROUP 70  
FIGURE 12  
PAGE 01

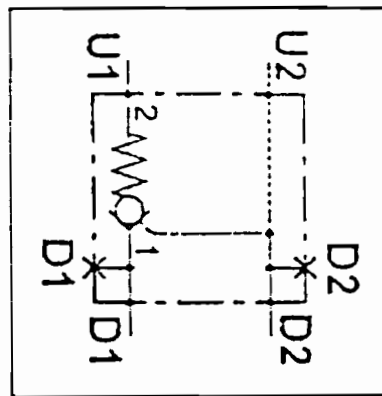
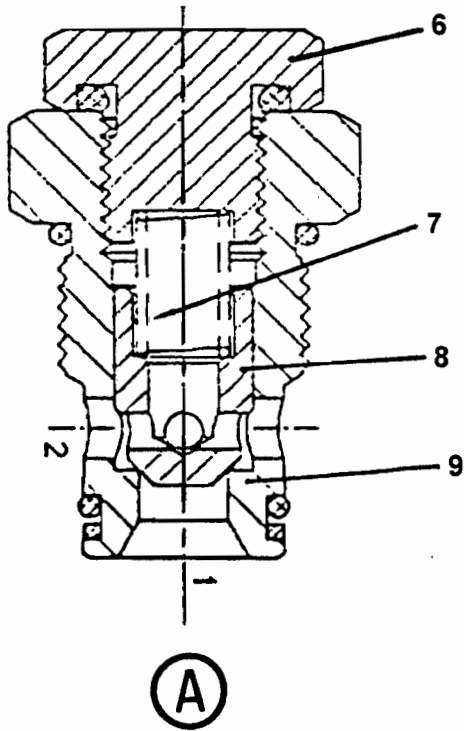
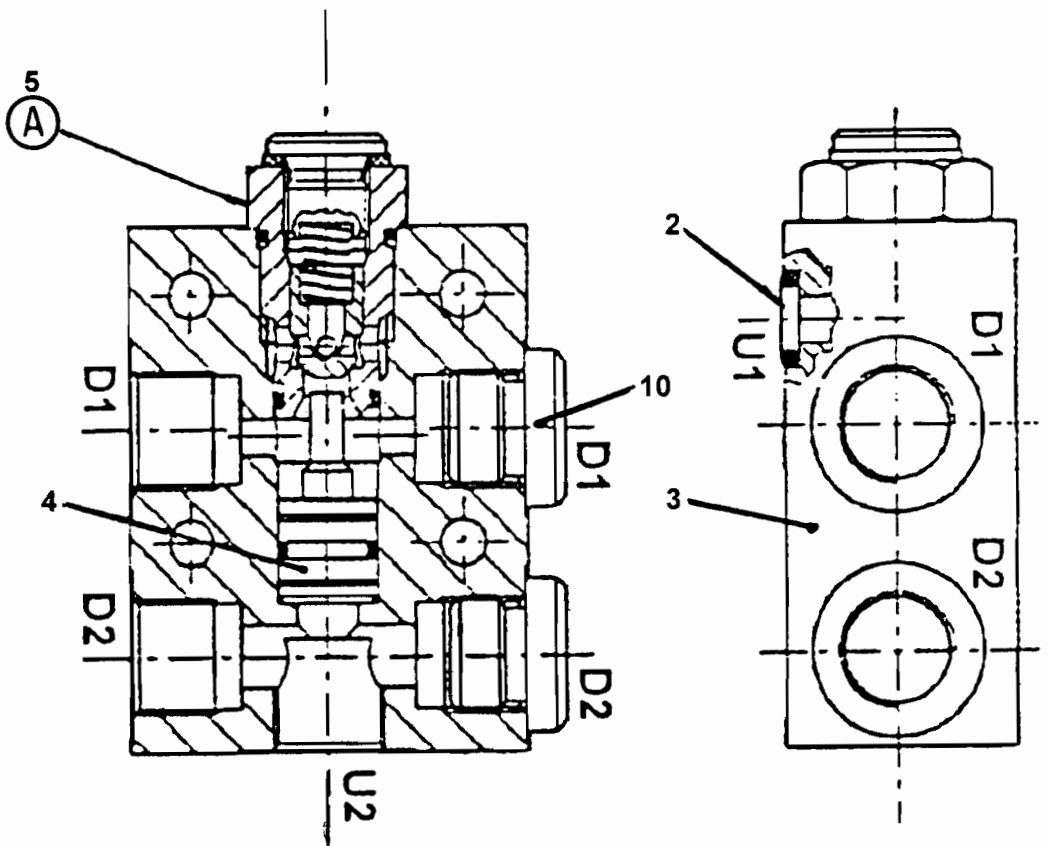



# OUTRIGGER HOLDING VALVE ASSEMBLY

**XT 36**  
**PARTS**  
GROUP 70  
FIGURE 12  
PAGE 02

ITEM NO.	REED'S PARTS NO.	DESCRIPTION					QTY
		1	2	3	4	5	
-1	802144	Assembly, Outrigger Holding Valve (See Group 70, Figure 01 for NHA)					Ref
2	C-WD201.01	• O-Ring					1
3	C-WD201.03	• Body, Outrigger Holding Valve					1
4	C-WD201.04	• Piston					1
5	C-WD201.05	• Valve, Holding (Complete Element)					1
6	C-WD201.05.3	• • Plug, Screw					1
7	C-WD201.05.4	• • Spring					1
8	C-WD201.05.2	• • Nozzle					1
9	C-WD201.05.1	• • Body, Element					1
10	C-WD201.02	• Plug, Screw					2

DASH (-) ITEM NOT ILLUSTRATED



**TRUCK MOUNTED CONCRETE PUMP XT36  
ILLUSTRATED PARTS MANUAL**

**XT 36  
PARTS  
GROUP 70  
FIGURE 13  
PAGE 01**

THIS PAGE INTENTIONALLY LEFT BLANK.

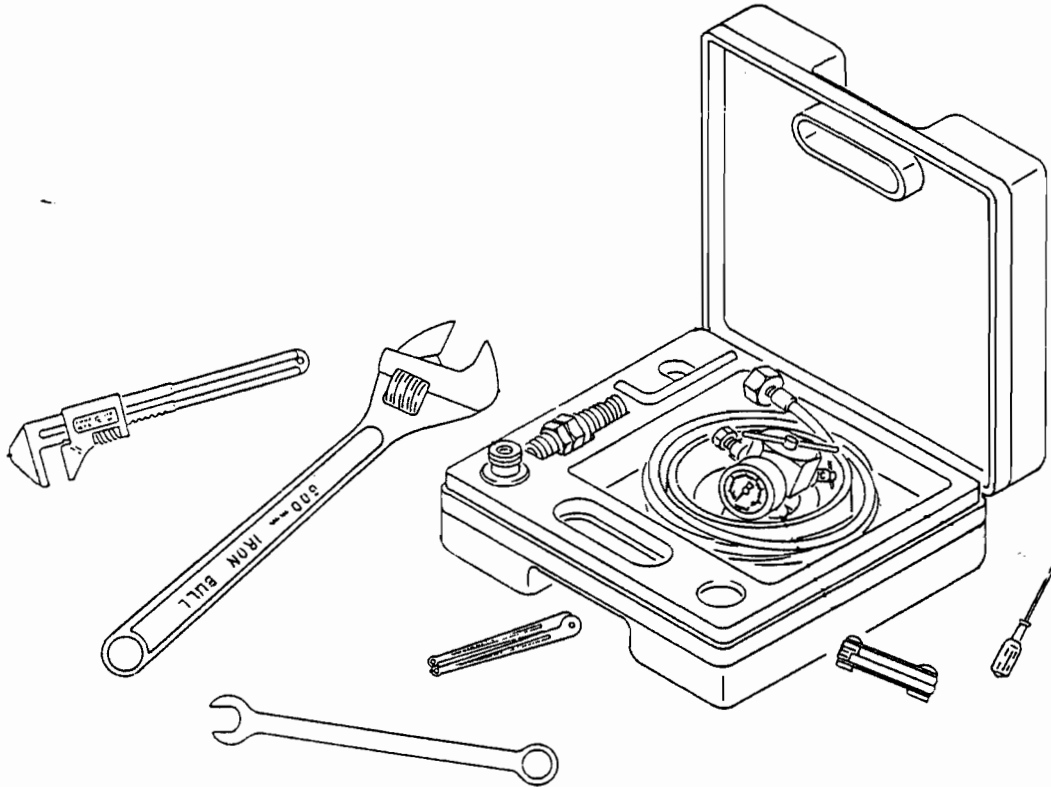

**REED TRUCK MOUNTED CONCRETE BOOM PUMP MODEL XT 36 ILLUSTRATED PARTS MANUAL GROUP 80 OPTIONAL INSTALLATION CONTAINS THE FOLLOWING FIGURES:**

- |                  |                                  |
|------------------|----------------------------------|
| <b>FIGURE 00</b> | <b>TABLE OF CONTENTS</b>         |
| <b>FIGURE 01</b> | <b>OPTIONAL INSTALLATION</b>     |
| <b>FIGURE 02</b> | <b>ACCUMULATOR CHARGE KIT</b>    |
| <b>FIGURE 03</b> | <b>OPTIONAL TOO KIT ASSEMBLY</b> |

**REED**

**OPTIONAL INSTALLATION**

**XT 36**  
**PARTS**  
GROUP 80  
FIGURE 01  
PAGE 01

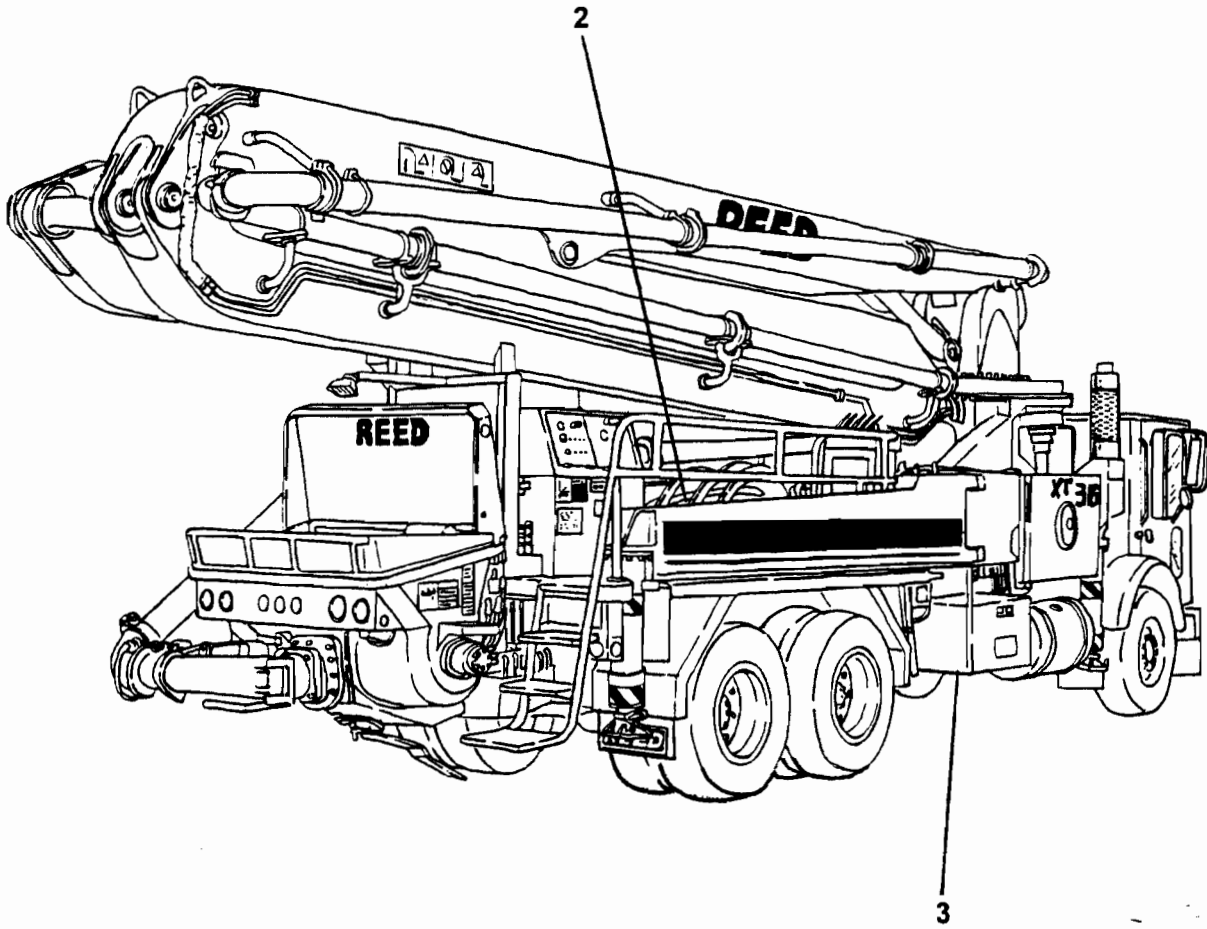

REVISION:





# OPTIONAL INSTALLATION

**XT 36**  
**PARTS**  
GROUP 80  
FIGURE 01  
PAGE 02

ITEM NO.	REED'S PARTS NO.	DESCRIPTION					QTY
		1	2	3	4	5	
-1	80-01	Installation, Optional (See Group 10, Figure 01 for NHA)					Ref
2	71460	• Kit, Accumulator Charge (See Group 80, Figure 04 for DET)					1
3	79020	• Assembly, Optional Tool Kit (See Group 80, Figure 06 for DET)					1

DASH (-) ITEM NOT ILLUSTRATED

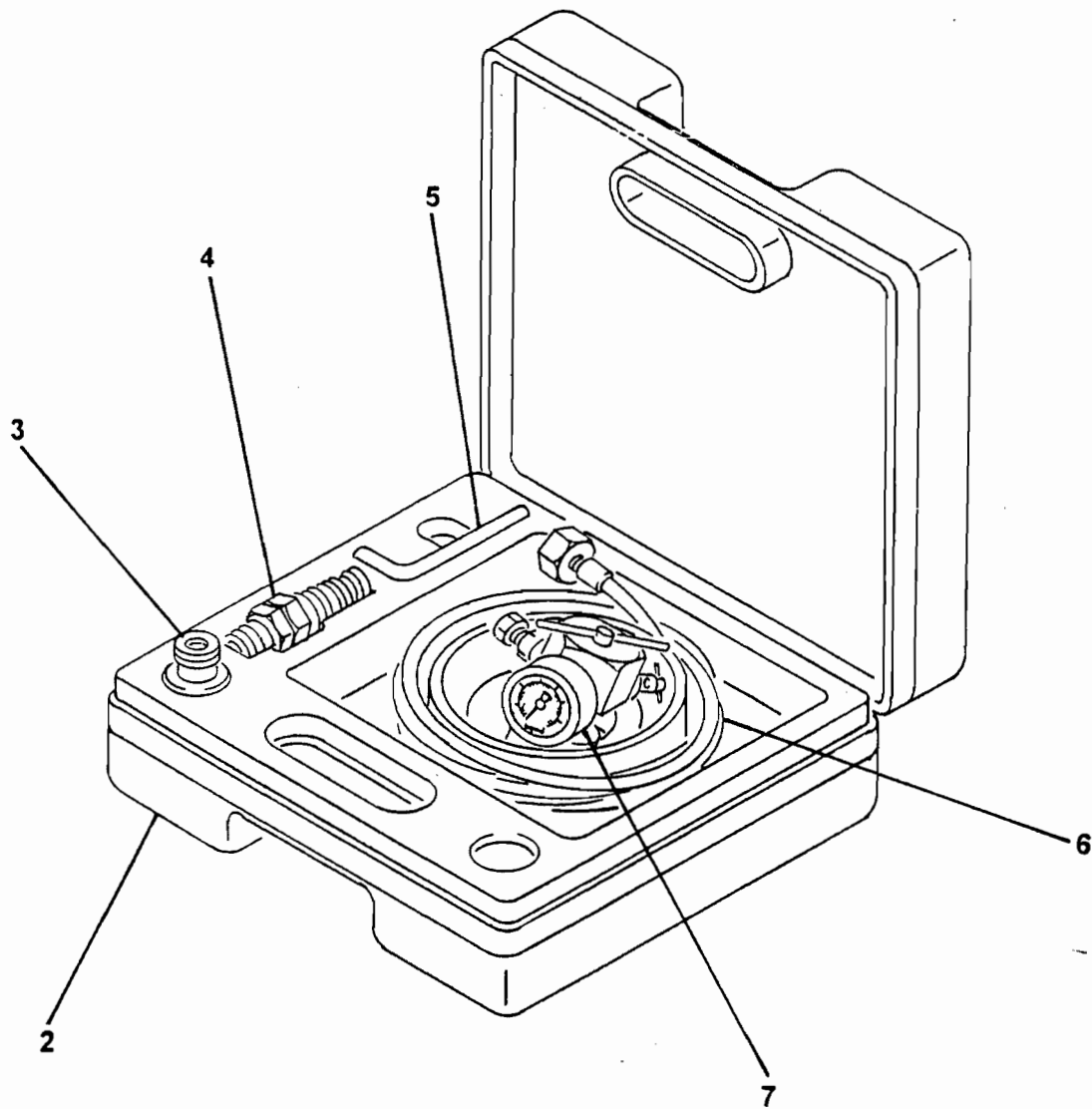

**REED****ACCUMULATOR CHARGE KIT****XT 36**  
**PARTS**  
GROUP 80  
FIGURE 02  
PAGE 02

ITEM NO.	REED'S PARTS NO.	DESCRIPTION					QTY
		1	2	3	4	5	
-1	71460	Kit, Accumulator Charge (See Group 80, Figure 01 for NHA)					Ref
2		• Case, Charge Kit					1
3		• Adapter, FPK / SB					1
4		• Adapter, G4					1
5		• Wrench, Allen					1
6		• Hose, Charging					1
7		• Unit, FPK Charging and Gagging					1

DASH (-) ITEM NOT ILLUSTRATED



# OPTIONAL TOOL KIT ASSEMBLY

XT 36  
PARTS  
GROUP 80  
FIGURE 03  
PAGE 01

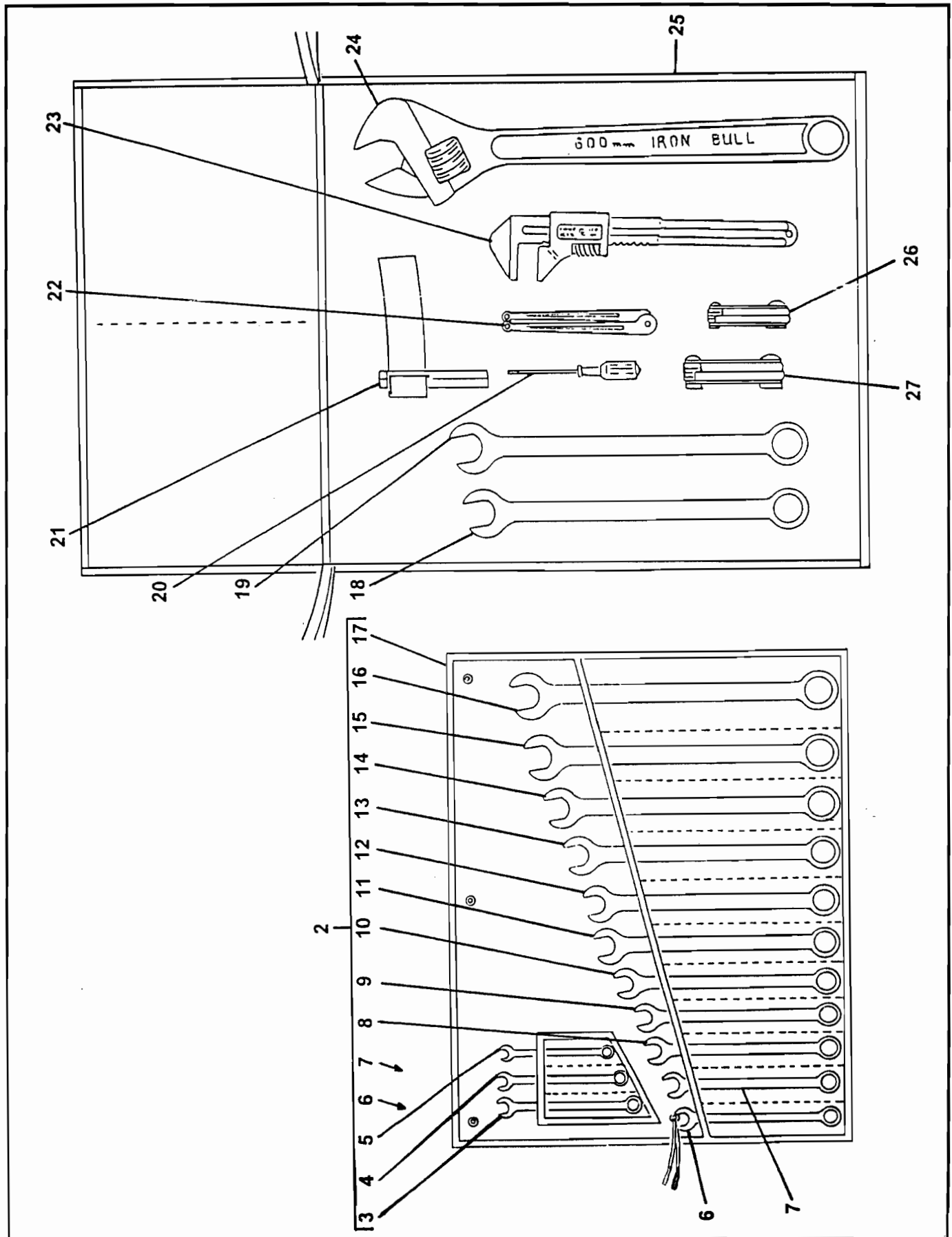

REVISION:

ITEM NO.	REED'S PARTS NO.	DESCRIPTION					QTY
		1	2	3	4	5	
-1	79020	Assembly, Optional Tool Kit (See Group 80, Figure 01 for NHA)					Ref
2	79037	• Kit, Wrench					1
3		• • Wrench, 1/2 Inch					1
4		• • Wrench, 7/16 Inch					1
5		• • Wrench, 3/8 Inch					1
6		• • Wrench, 9/16 Inch					1
7		• • Wrench, 5/8 Inch					1
8		• • Wrench, 11/16 Inch					1
9		• • Wrench, 3/4 Inch					1
10		• • Wrench, 13/16 Inch					1
11		• • Wrench, 7/8 Inch					1
12		• • Wrench, 15/16 Inch					1
13		• • Wrench, 1 Inch					1
14		• • Wrench, 1-1/16 Inch					1
15		• • Wrench, 1-1/8 Inch					1
16		• • Wrench, 1-1/4 Inch					1
17		• • Wrap, Plastic					1
18	79036	• Wrench, 1-3/8 Inch					1
19	79028	• Wrench, 1-1/2 Inch					1
20	79038	• Screwdriver					1
21	79814	• Wrench, Strap (for Filter)					1
22	79325	• Wrench, Spanner					1
23	79031	• Wrench, Monkey					1
24	79032	• Wrench, Adjustable 24 Inch					1
25	77502	• Bag, Tool					1
26	79030	• Set, Metric Allen Key (2-8 mm)					1
27	79029	• Set, Standard Allen Key (3/16-3/8 Inch)					1

DASH (-) ITEM NOT ILLUSTRATED

**REED**

**MODEL XT 36 TRUCK MOUNTED  
CONCRETE BOOM PUMP  
ILLUSTRATED PARTS MANUAL**

**XT 36  
PARTS  
GROUP 80  
FIGURE 04  
PAGE 01**

THIS PAGE INTENTIONALLY LEFT BLANK.

**REED** TRUCK MOUNTED CONCRETE BOOM PUMP MODEL **XT 36**  
ILLUSTRATED PARTS MANUAL GROUP 90 BOOM INSTALLATION  
CONTAINS THE FOLLOWING FIGURES:

<b>FIGURE 00</b>	TABLE OF CONTENTS
<b>FIGURE 01</b>	BOOM INSTALLATION
<b>FIGURE 02</b>	FIRST BOOM ASSEMBLY
<b>FIGURE 03</b>	SECOND BOOM ASSEMBLY
<b>FIGURE 04</b>	THIRD BOOM ASSEMBLY
<b>FIGURE 05</b>	FOURTH BOOM ASSEMBLY
<b>FIGURE 06</b>	FIRST BOOM CYLINDER ASSEMBLY
<b>FIGURE 07</b>	SECOND BOOM CYLINDER ASSEMBLY
<b>FIGURE 08</b>	THIRD BOOM CYLINDER ASSEMBLY
<b>FIGURE 09</b>	FOURTH BOOM CYLINDER ASSEMBLY
<b>FIGURE 10</b>	BOOM DELIVERY LINE ASSEMBLY
<b>FIGURE 11</b>	DECK DELIVERY LINE ASSEMBLY

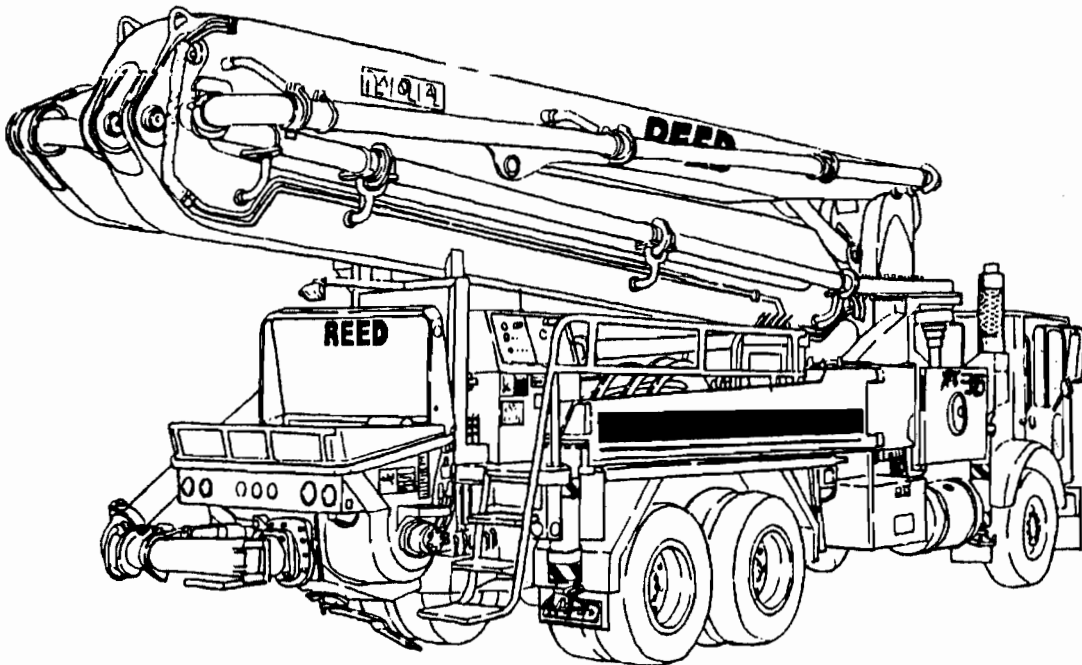



# BOOM INSTALLATION

XT 36  
PARTS  
GROUP 90  
FIGURE 01  
PAGE 01

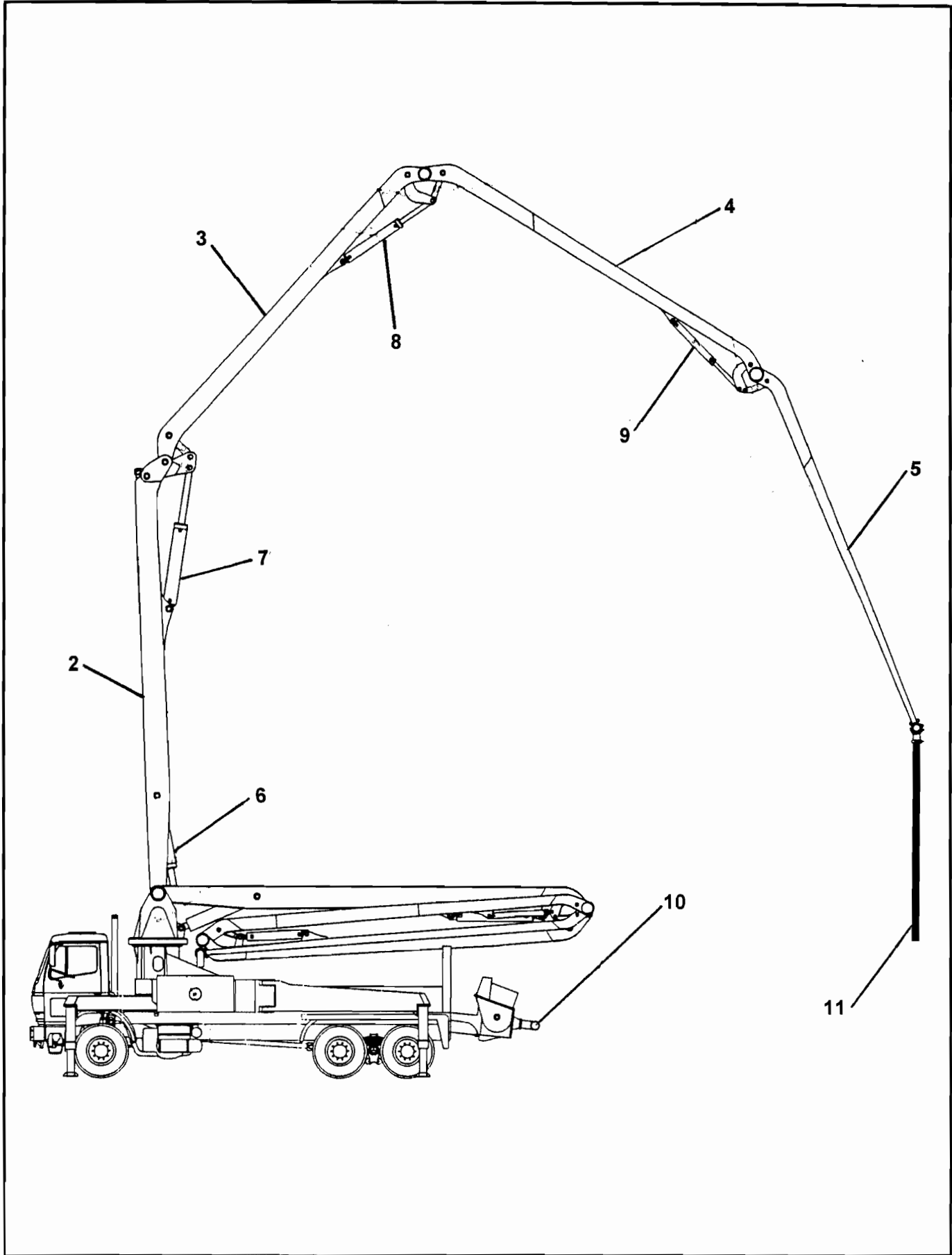



ITEM NO.	REED'S PARTS NO.	DESCRIPTION					QTY
		1	2	3	4	5	
-1	90-01	Installation, Boom (See Group 10, Figure 01 for NHA)					Ref
2	802001	• Assembly, <b>XT 36</b> First Boom (See Group 90, Figure 02 for DET)					1
3	802006	• Assembly, <b>XT 36</b> Second Boom (See Group 90, Figure 03 for DET)					1
4	802011	• Assembly, <b>XT 36</b> Third Boom (See Group 90, Figure 04 for DET)					1
5	802016	• Assembly, <b>XT 36</b> Fourth Boom (See Group 90, Figure 05 for DET)					1
6	802003	• Assembly, <b>XT 36</b> First Boom Cylinder (See Group 90, Figure 06 for DET)					1
7	802008	• Assembly, <b>XT 36</b> Second Boom Cylinder (See Group 90, Figure 07 for DET)					1
8	802013	• Assembly, <b>XT 36</b> Third Boom Cylinder (See Group 90, Figure 08 for DET)					1
9	802018	• Assembly, <b>XT 36</b> Fourth Boom Cylinder (See Group 90, Figure 09 for DET)					1
10	90-10	• Assembly, <b>XT 36</b> Concrete Pipe Line (Deck Area) (See Group 90, Figure 10 for DET)					1
11	C-1T	• Assembly, Concrete Pipe Line (Boom Area) (See Group 90, Figure 11 for DET)					1

DASH (-) ITEM NOT ILLUSTRATED

## FIRST BOOM ASSEMBLY

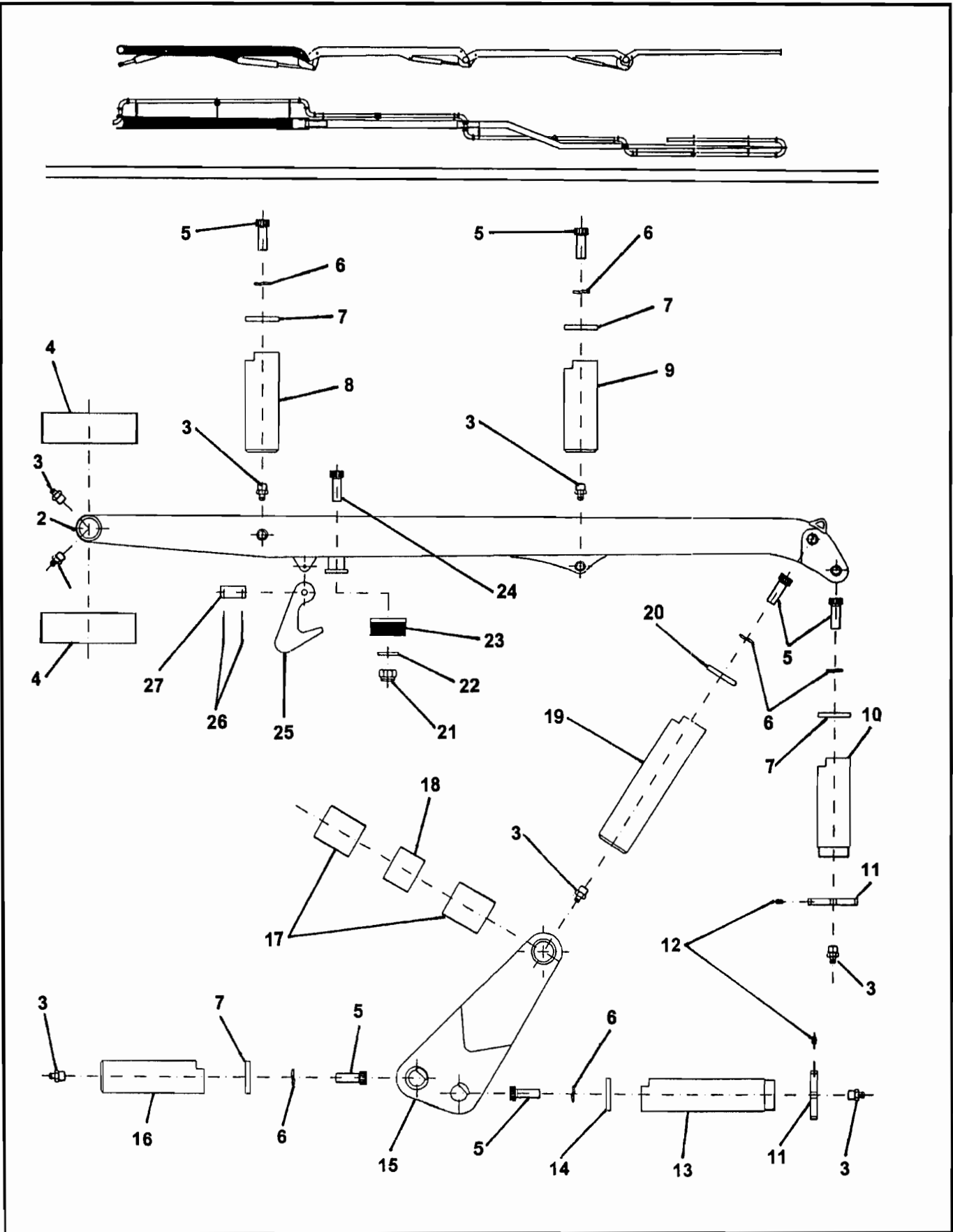

REVISION:



# FIRST BOOM ASSEMBLY

**XT 36**  
**PARTS**  
GROUP 90  
FIGURE 02  
PAGE 02

ITEM NO.	REED'S PARTS NO.	1 2 3 4 5	DESCRIPTION	QTY
-1	802001		Assembly, <b>XT 36</b> First Boom (See Group 90, Figure 01 for NHA)	Ref
2	802002		• Weldment, <b>XT 36</b> First Boom	1
3	C-VI131.1010		• Nipple, Grease	9
4	C-CD230.235090		• Bearing, First Boom Pin	2
5	C-VC110.101525		• Screw	7
6	C-UE110.10		• Washer, Elastic	7
7	802045		• Washer, Pin	5
8	802022		• Pin, Pivot	1
9	802023		• Pin, Pivot	1
10	802024		• Pin, Second Boom	2
11	802040		• Ring, Thread Pin	3
12	C-VG120.061010		• Screw	4
13	802027		• Pin, Pivot	1
14	802046		• Washer, Pin	1
15	802004		• Link, Second Boom Lever	1
16	802026		• Pin, Pivot	1
17	802054		• Bearing	2
18	802065		• Spacer, Pin	1
19	802025		• Pin, Pivot	1
20	802045		• Washer, Pin	1
21	C-VD212.1015		• Nut, Self Locking	2
22	C-UP110.10		• Washer	2
23	802070		• Pad, Rubber	1
24	C-VC110.101530		• Screw	2
25	802068		• Hook, First Boom	1
26	C-VS110.04050		• Pin, Split	2
27	802069		• Pin, Hook	1

DASH (-) ITEM NOT ILLUSTRATED

REVISION:

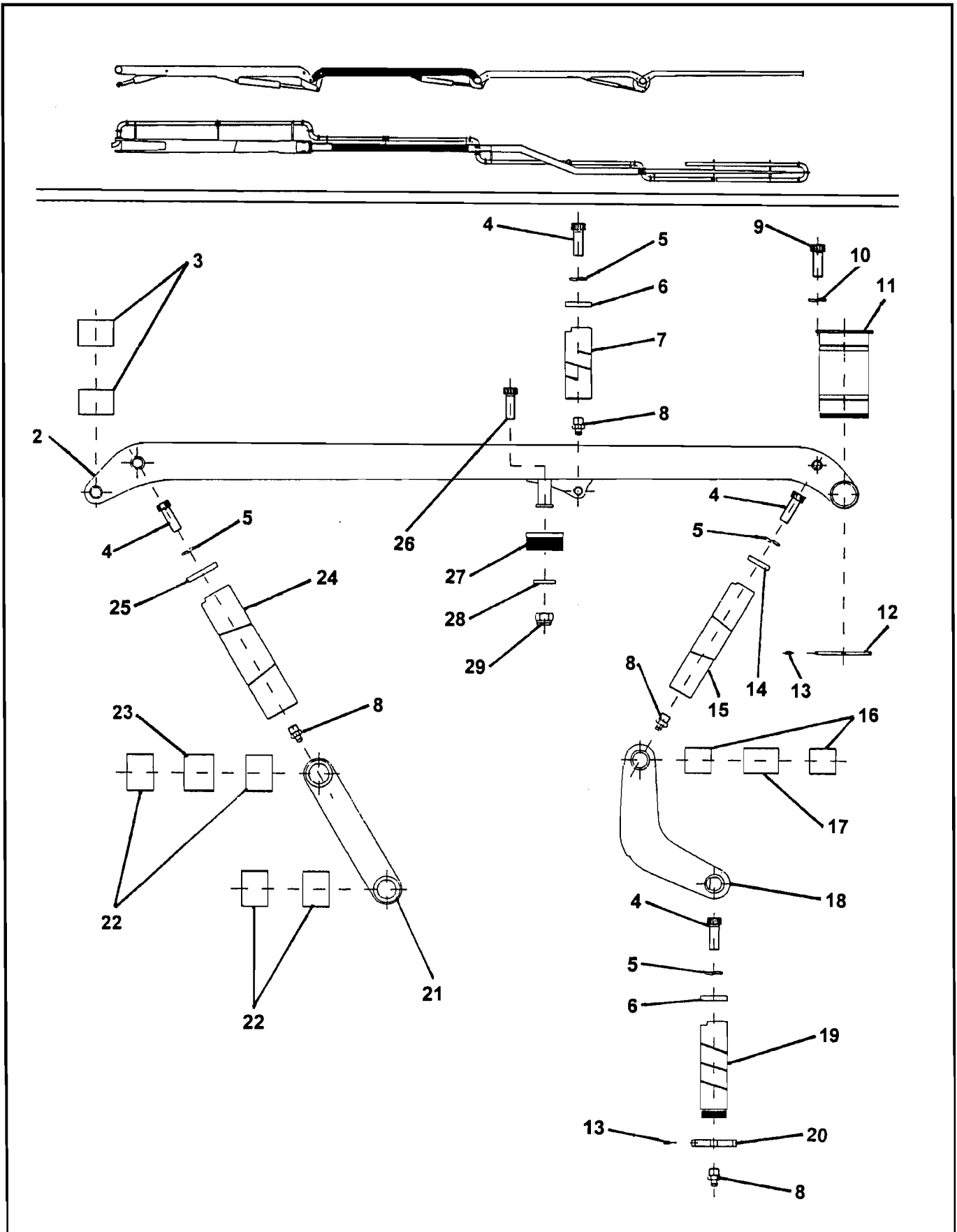

REVISION:

ITEM NO.	REED'S PARTS NO.	DESCRIPTION					QTY
		1	2	3	4	5	
-1	802006	Assembly, <i>XT 36</i> Second Boom (See Group 90, Figure 01 for NHA)					Ref
2	802007	• Weldment, <i>XT 36</i> Second Boom					1
3	802055	• Bearing					2
4	C-VC110.101525	• Screw					4
5	C-UE110.10	• Washer, Elastic					4
6	802047	• Washer, Pin					2
7	802029	• Pin, Pivot					1
8	C-VI131.1010	• Nipple, Grease					4
9	C-VC110.081220	• Screw					4
10	C-UE110.08	• Washer, Elastic					4
11	802030	• Pin, Third Boom Hollow					1
12	802041	• Ring, Third Boom Pin Threaded					1
13	C-VG122.061010	• Screw					4
14	802048	• Washer, Pin					1
15	802031	• Pin, Pivot					1
16	802057	• Bearing					2
17	802066	• Spacer, Pin					1
18	802009	• Link, Third Boom Lever					1
19	802032	• Pin, Pivot					1
20	802042	• Ring, Thread Pin					1
21	802005	• Link, Second Boom Pressure					1
22	802056	• Bearing					4
23	802067	• Spacer, Pin					1
24	802028	• Pin, Pivot					1
25	802046	• Washer, Pin					1
26	C-VC110.101530	• Screw					2
27	802070	• Pad, Rubber					1
28	C-UP110.10	• Washer					2
29	C-VD221.1015	• Nut, Self Locking					2

DASH (-) ITEM NOT ILLUSTRATED

## THIRD BOOM ASSEMBLY

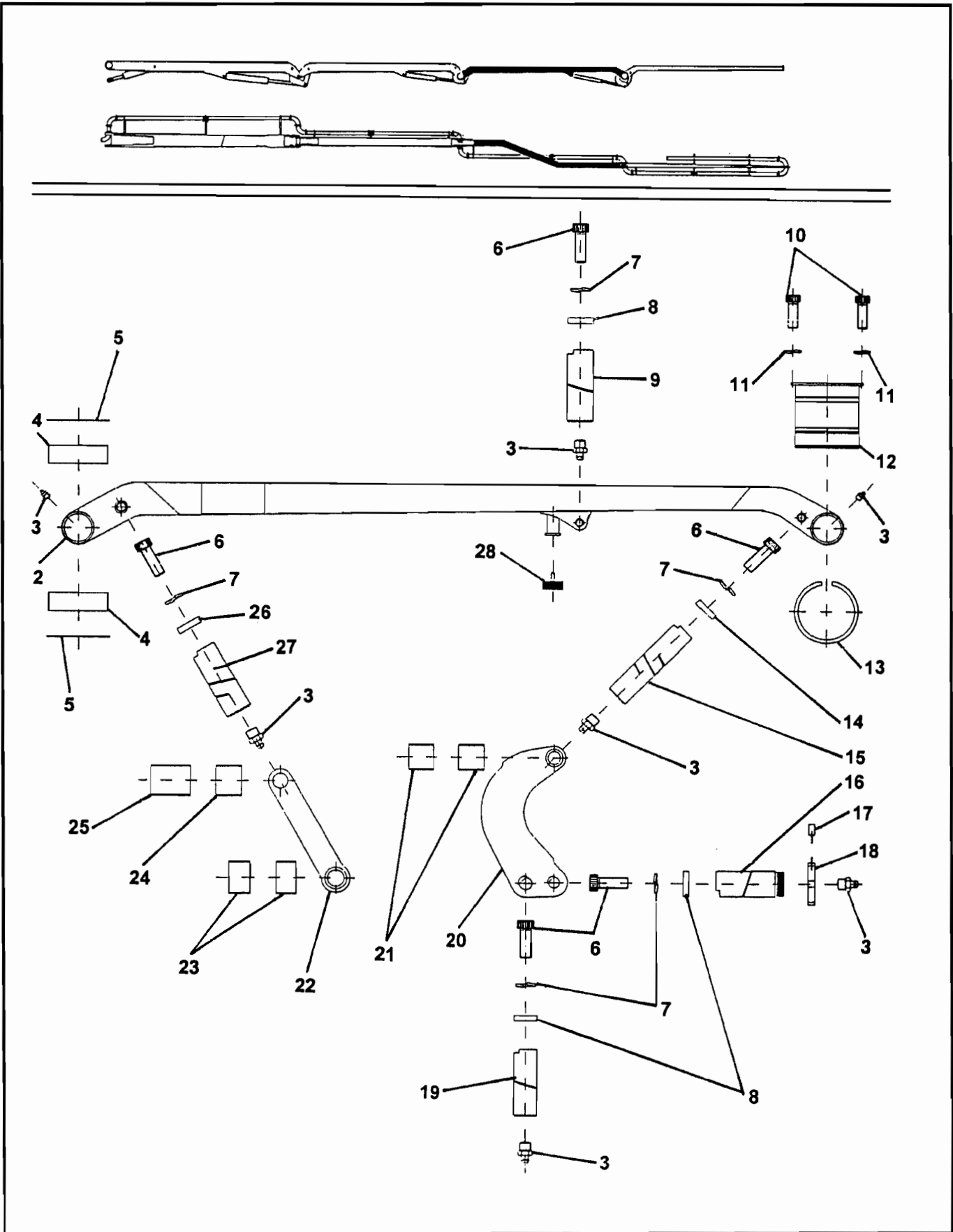

REVISION:

ITEM NO.	REED'S PARTS NO.	DESCRIPTION					QTY
		1	2	3	4	5	
-1	802011	Assembly, <b>XT 36</b> Third Boom (See Group 90, Figure 01 for NHA)					Ref
2	802012	• Weldment, <b>XT 36</b> Third Boom					1
3	C-VI131.1010	• Nipple, Grease					9
4	802052	• Bearing					2
5	802063	• Ring, Wear					2
6	C-VC110.101525	• Screw					5
7	C-UE110.10	• Washer, Elastic					5
8	802049	• Washer, Pin					3
9	802034	• Pin, Pivot					1
10	C-VC110.081220	• Screw					5
11	C-UE110.08	• Washer, Elastic					5
12	802035	• Pin, Fourth Boom Hollow					1
13	802043	• Ring, Fourth Boom Pin Retaining					1
14	802050	• Washer, Pin					1
15	802036	• Pin, Pivot					1
16	802038	• Pin, Pivot					1
17	C-VG122.061010	• Screw					2
18	802044	• Ring, Threaded Pin					1
19	802037	• Pin, Pivot					1
20	802014	• Link, Fourth Boom Lever					1
21	802061	• Bearing					2
22	802010	• Link, Third Boom Pressure					1
23	802058	• Bearing					2
24	802059	• Bearing					1
25	802060	• Bearing					1
26	802047	• Washer, Pin					1
27	802033	• Pin, Pivot					1
28	802071	• Pad, Rubber					1

DASH (-) ITEM NOT ILLUSTRATED

## FOURTH BOOM ASSEMBLY

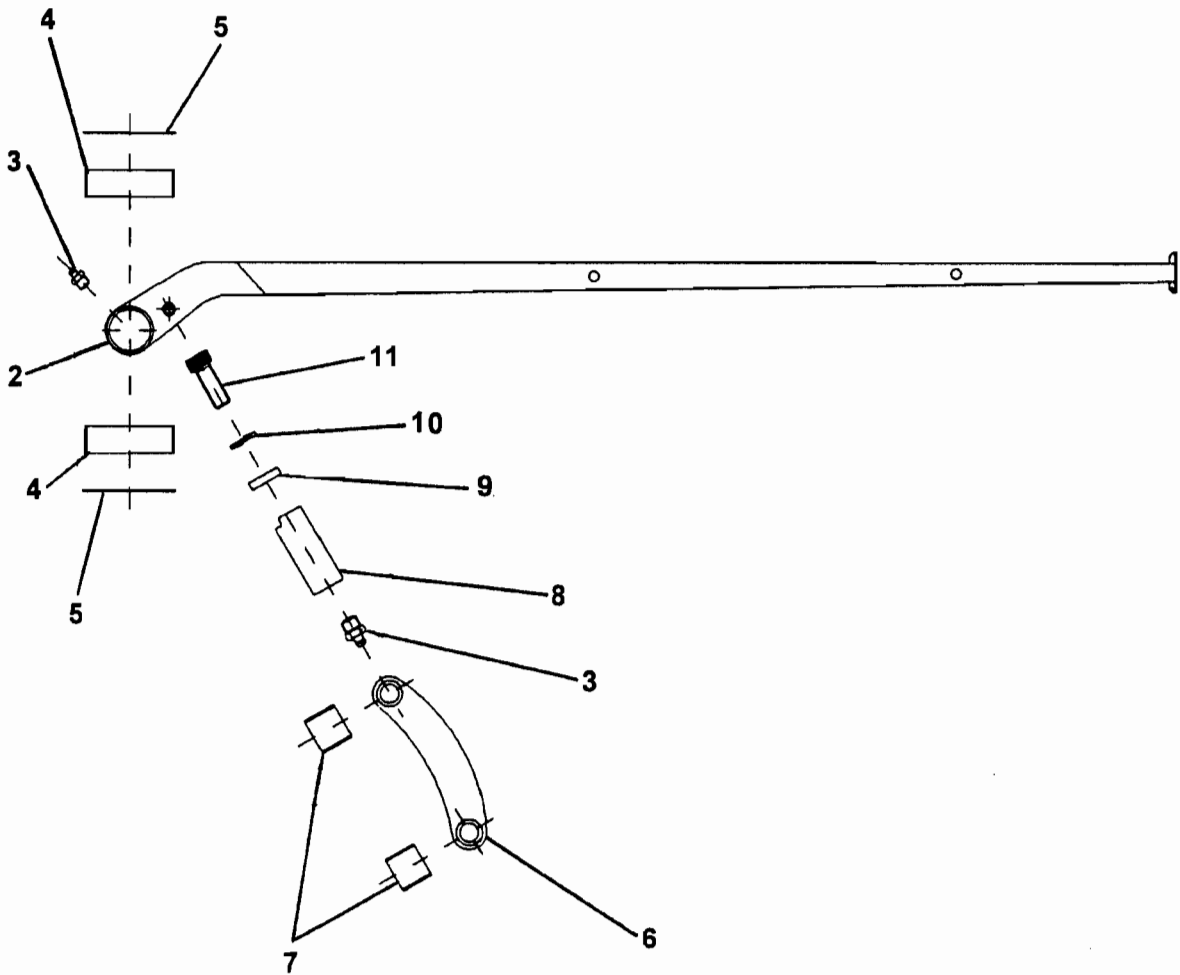
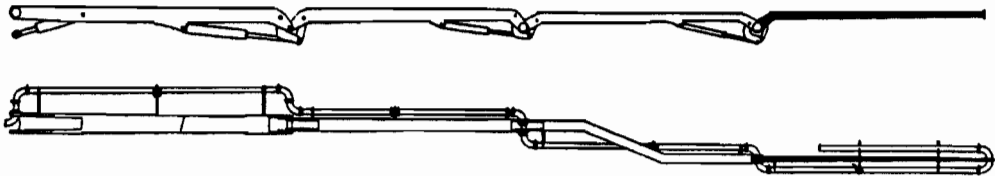

REVISION:



ITEM NO.	REED'S PARTS NO.	DESCRIPTION					QTY
		1	2	3	4	5	
-1	802016	Assembly, <i>XT 36</i> Fourth Boom (See Group 90, Figure 01 for NHA)					Ref
2	802017	• Weldment, <i>XT 36</i> Fourth Boom					1
3	C-VI131.1010	• Nipple, Grease					3
4	802053	• Bearing					2
5	802064	• Ring, Wear					2
6	802015	• Link, Fourth Boom Pressure					1
7	802062	• Bearing					2
8	802034	• Pin, Pivot					1
9	802049	• Washer, Pin					1
10	C-UE110.10	• Washer, Elastic					1
11	C-VC110.101525	• Screw					1

DASH (-) ITEM NOT ILLUSTRATED

## XT 36 FIRST BOOM CYLINDER ASSEMBLY

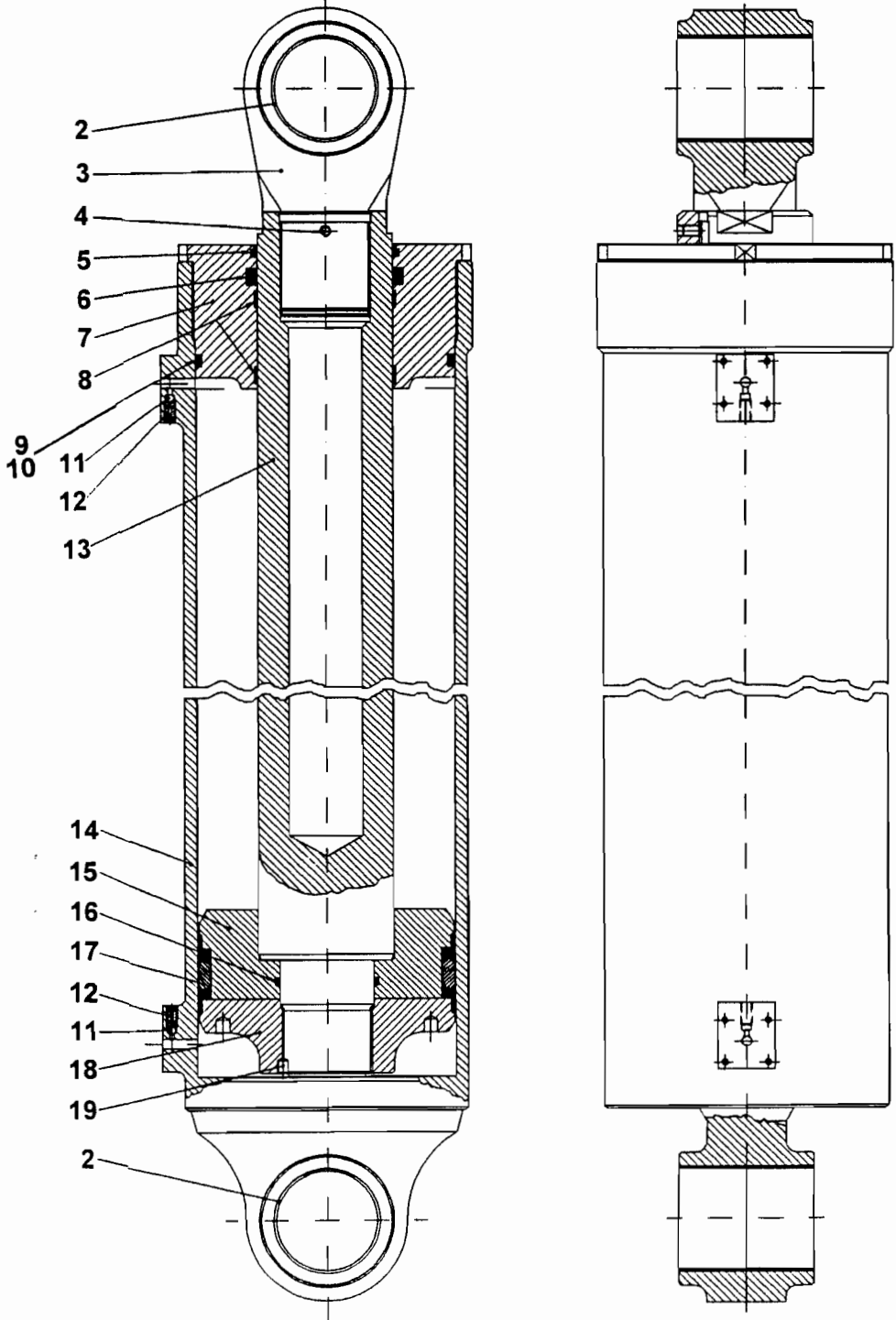
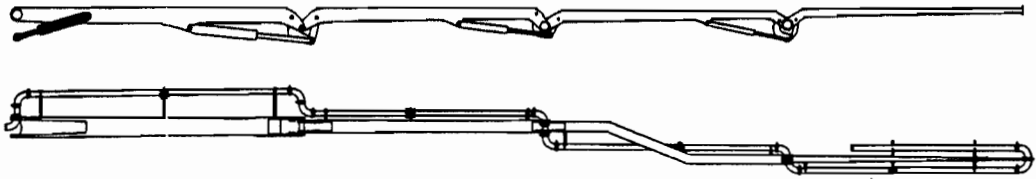



# XT 36 FIRST BOOM CYLINDER ASSEMBLY

**XT 36**  
**PARTS**  
GROUP 90  
FIGURE 06  
PAGE 02

ITEM NO.	REED'S PARTS NO.	DESCRIPTION					QTY
		1	2	3	4	5	
-1	W-106189	Assembly, XT 36 First Boom Cylinder (See Group 90, Figure 01 for NHA)					Ref
2	802055	• Bearing					4
3	C-1B108	• Cap, Rod					1
4	C-VG122.101515	• Screw					1
5	C-BR310.120	• Gasket, Seal					1
6	C-BT110.120	• Gasket, Seal					1
7	W-106720	• Head, Slide Rod					1
8	C-AG123.120	• Ring, Slide Rod					2
9	C-AO120.371	• Ring, Sealing					1
10	C-AP110.372	• Seal, Gasket					1
11	C-CS100.007	• Ball, Still					2
12	C-WPVS1	• Valve, Air Hole					2
13	C-1B107	• Rod					1
14	C-1B102	• Cylinder					1
15	C-3B112	• Piston					1
16	C-AO420.6325	• Ring, Sealing					1
17	C-BS229058071A	• Gasket, Seal					1
18	C-3B109A	• Nut, Rod					1
19	C-VG121.101512	• Screw					1

DASH (-) ITEM NOT ILLUSTRATED



# XT 36 SECOND BOOM CYLINDER ASSEMBLY

**XT 36**  
**PARTS**  
GROUP 90  
FIGURE 07  
PAGE 01

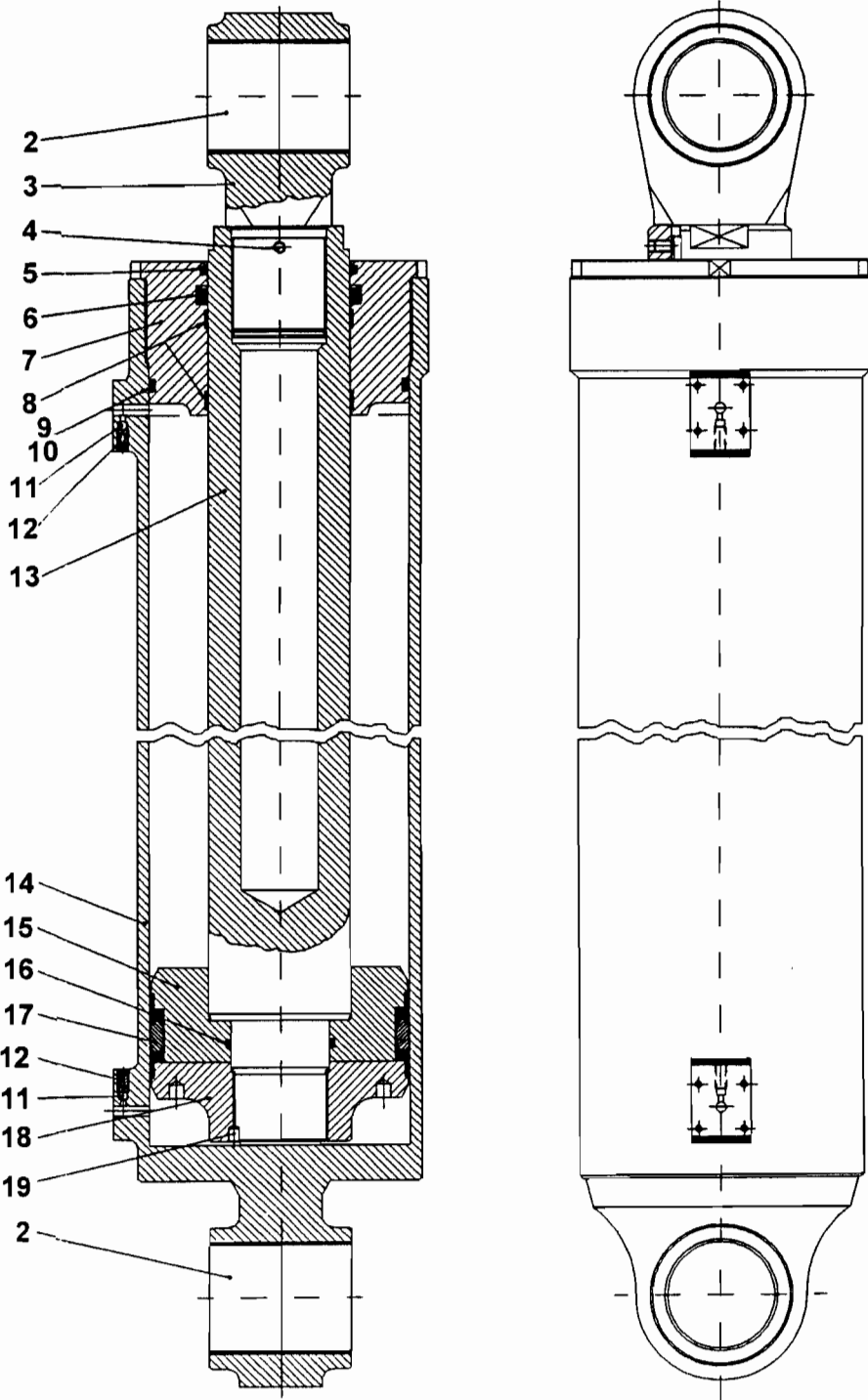
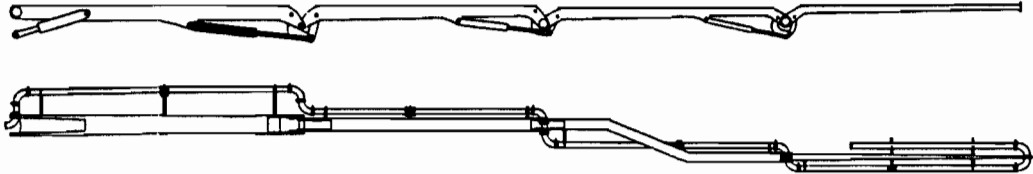



# XT 36 SECOND BOOM CYLINDER ASSEMBLY

**XT 36**  
**PARTS**  
GROUP 90  
FIGURE 07  
PAGE 02

ITEM NO.	REED'S PARTS NO.	DESCRIPTION					QTY
		1	2	3	4	5	
-1	802008	Assembly, <i>XT 36</i> Second Boom Cylinder (See Group 90, Figure 01 for NHA)					Ref
2	802055	• Bearing					4
3	C-1B108	• Cap, Rod					1
4	C-VG122.101515	• Screw					1
5	C-BR310.120	• Gasket, Seal					1
6	C-BT110.120	• Gasket, Seal					1
7	C-1B201A	• Head, Slide Rod					1
8	C-AG123.120	• Ring, Slide Rod					2
9	C-AO120.370	• Ring, Sealing					1
10	C-AP110.370	• Seal, Gasket					1
11	C-CS100.007	• Ball, Steel					2
12	C-WPVS1	• Valve, Air Hole					2
13	C-1B207	• Rod					1
14	C-1B202A	• Cylinder					1
15	C-1B212A	• Piston					1
16	C-AO420.6325	• Ring, Sealing					1
17	C-BS229058071A	• Ring, Sealing					1
18	C-1B209A	• Nut, Rod					1
19	C-VG122.101512	• Screw					1

DASH (-) ITEM NOT ILLUSTRATED



# XT 36 THIRD BOOM CYLINDER ASSEMBLY

XT 36  
PARTS  
GROUP 90  
FIGURE 08  
PAGE 01

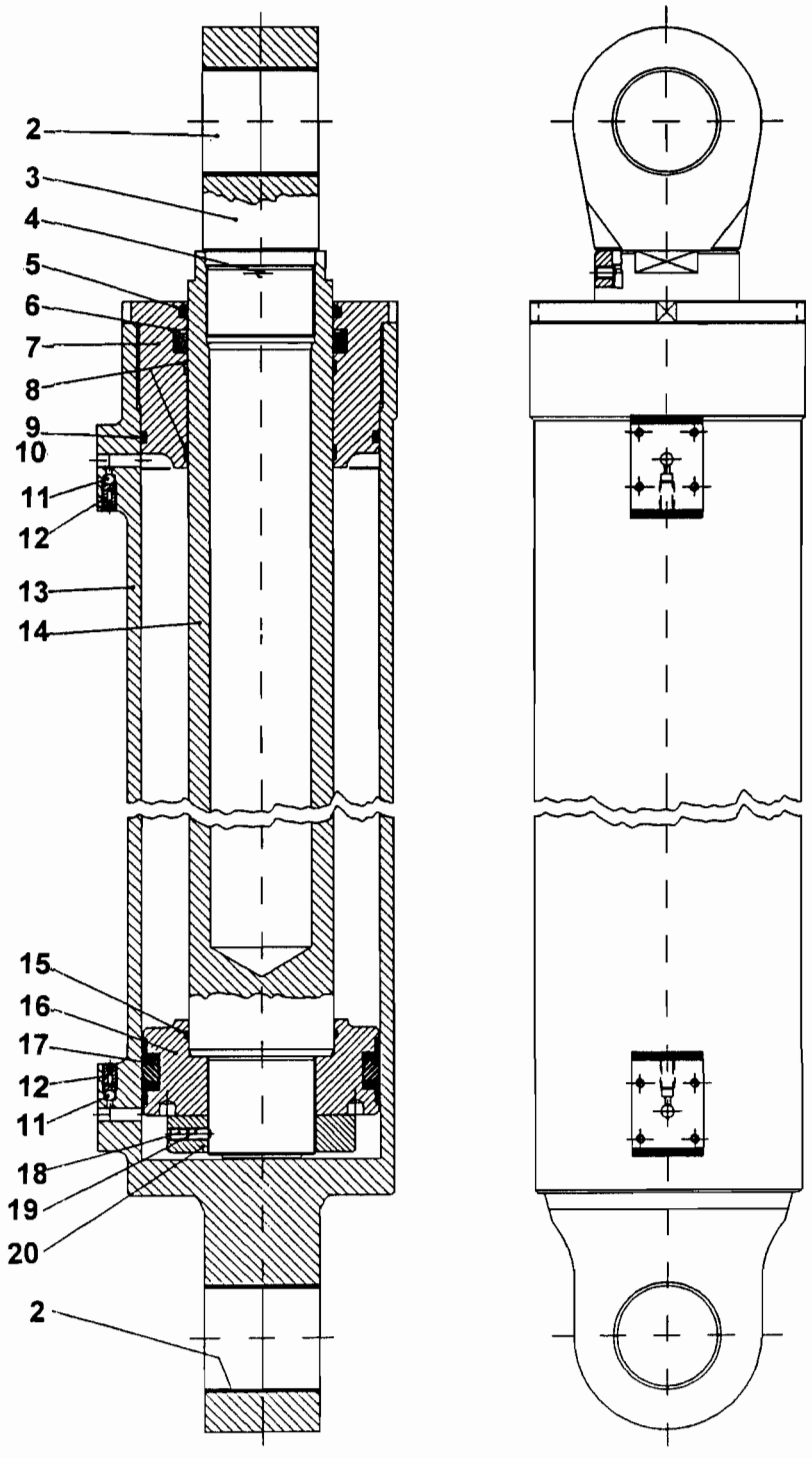
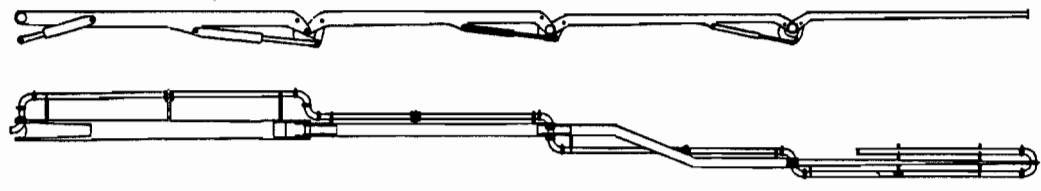

ITEM NO.	REED'S PARTS NO.	DESCRIPTION					QTY
		1	2	3	4	5	
-1	802013	Assembly, <b>XT 36</b> Third Boom Cylinder (See Group 90, Figure 01 for NHA)					Ref
2	802058	• Bearing					4
3	C-1B308	• Cap, Rod					1
4	C-VG122.081212	• Screw					1
5	C-BR310.100	• Gasket, Seal					1
6	C-BT110.100	• Gasket, Seal					1
7	C-1B301	• Head, Slide Rod					1
8	C-AG122.100	• Ring, Slide Rod					2
9	C-AP110.361	• Seal, Gasket					1
10	C-AO120.361	• Ring, Sealing					1
11	C-CS100.007	• Ball, Steel					2
12	C-WPVS1	• Valve, Air Hole					2
13	C-1B302	• Cylinder					1
14	C-1B307A	• Rod					1
15	C-AO420.4387	• Ring, Seal					1
16	C-1B312A	• Piston					1
17	C-BS23649551	• Gasket, Seal					1
18	C-VG122.081212	• Screw					1
19	C-VG122.081215	• Screw					1
20	C-1B3090	• Nut, Rod					1

DASH (-) ITEM NOT ILLUSTRATED



# XT 36 FOURTH BOOM CYLINDER ASSEMBLY

**XT 36**  
**PARTS**  
GROUP 90  
FIGURE 09  
PAGE 01

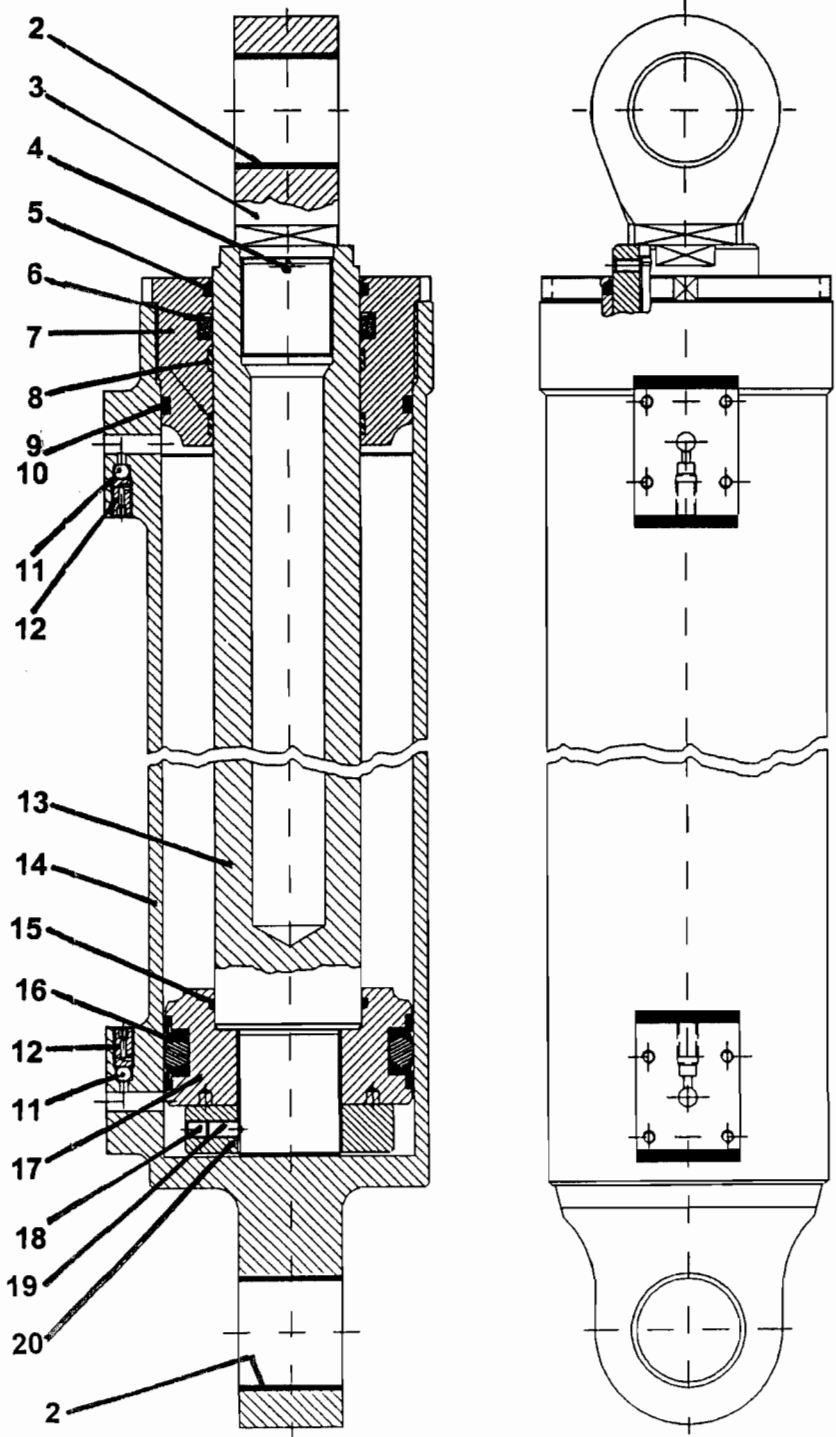
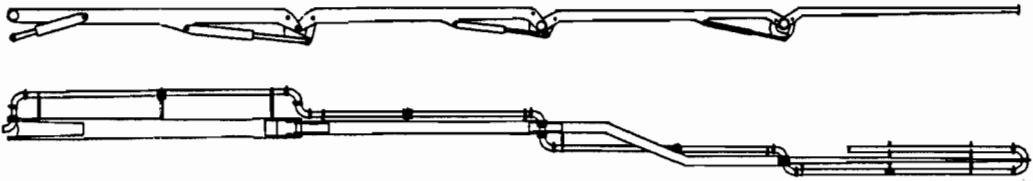





# XT 36 FOURTH BOOM CYLINDER ASSEMBLY

**XT 36**  
**PARTS**  
GROUP 90  
FIGURE 09  
PAGE 02

ITEM NO.	REED'S PARTS NO.	DESCRIPTION					QTY
		1	2	3	4	5	
-1	802018	Assembly, <b>XT 36</b> Fourth Boom Cylinder (See Group 90, Figure 01 for NHA)					Ref
2	802062	• Bearing					4
3	C-1B408	• Cap, Rod					4
4	C-VG122.061012	• Screw					1
5	C-BR310.070	• Gasket, Seal					1
6	C-BT110.070	• Gasket, Seal					1
7	C-3B401	• Head, Slide Rod					1
8	C-AG122.070	• Ring, Slide Rod					2
9	C-AP110.348	• Seal, Gasket					1
10	C-AO120.348	• Ring, Sealing					1
11	C-CS100.007	• Ball, Steel					2
12	C-WPVS1	• Valve, Air Hole					2
13	C-1B407A	• Rod					1
14	C-1B402	• Cylinder					1
15	C-AO420.4275	• Ring, Sealing					1
16	C-BS23472374	• Gasket, Seal					1
17	C-3B412B	• Piston					1
18	C-VG121.081212	• Screw					1
19	C-VG121.081215	• Screw					1
20	C-3B409	• Nut, Rod					1

DASH (-) ITEM NOT ILLUSTRATED



# BOOM DELIVERY LINE ASSEMBLY

XT 36  
PARTS  
GROUP 90  
FIGURE 10  
PAGE 01

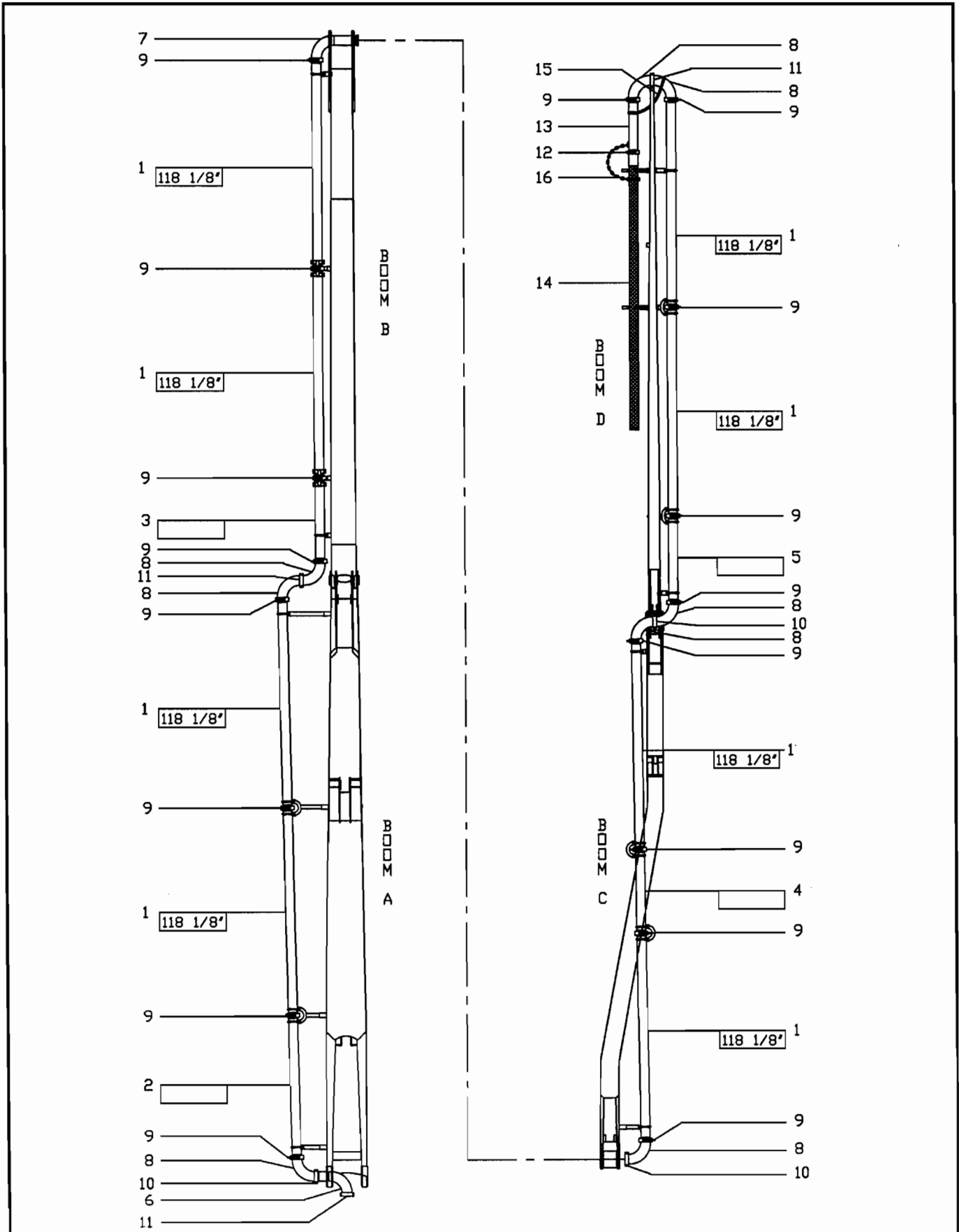

REVISION:



# BOOM DELIVERY LINE ASSEMBLY

**XT 36**  
**PARTS**  
 GROUP 90  
 FIGURE 10  
 PAGE 02

ITEM NO.	REED'S PARTS NO.	DESCRIPTION	QTY
	90-10	Assembly, Boom Delivery Line (See Group 90, Figure 01 for NHA)	Ref
1	801105-3000	• Boom Pipe, 3000mm	1
2	801105-XXXX	• Boom Pipe, Makeup-A Boom	1
3	801105-XXXX	• Boom Pipe, Makeup-B Boom	1
4	801105-XXXX	• Boom Pipe, Makeup-C Boom	1
5	801105-XXXX	• Boom Pipe, Makeup-D Boom	1
6	802420	• Boom Elbow, 449mm Leg	1
7	802423	• Boom Elbow, 608mm Leg	1
8	800327	• Boom Elbow	8
9	800070	• Snap Coupling, 148mm	16
10	802091	• Two Bolt Coupling, 148mm	1
11	802092	• Two Bolt Coupling, 148mm w/Base	1
		<b>END HOSE – 4 INCH</b>	
9	800070	• Snap Coupling, 148mm	1
12	71530	• Snap Coupling, 4" HD	1
13	800067	• Reducer, 148mm x 4" HD	1
14	800068	• End Hose, 4 IN x 10 FT	1
15	801770	• Web Sling	1
16	801671	• Chain	1FT
		DASH (-) ITEM NOT ILLUSTRATED	

REVISION:

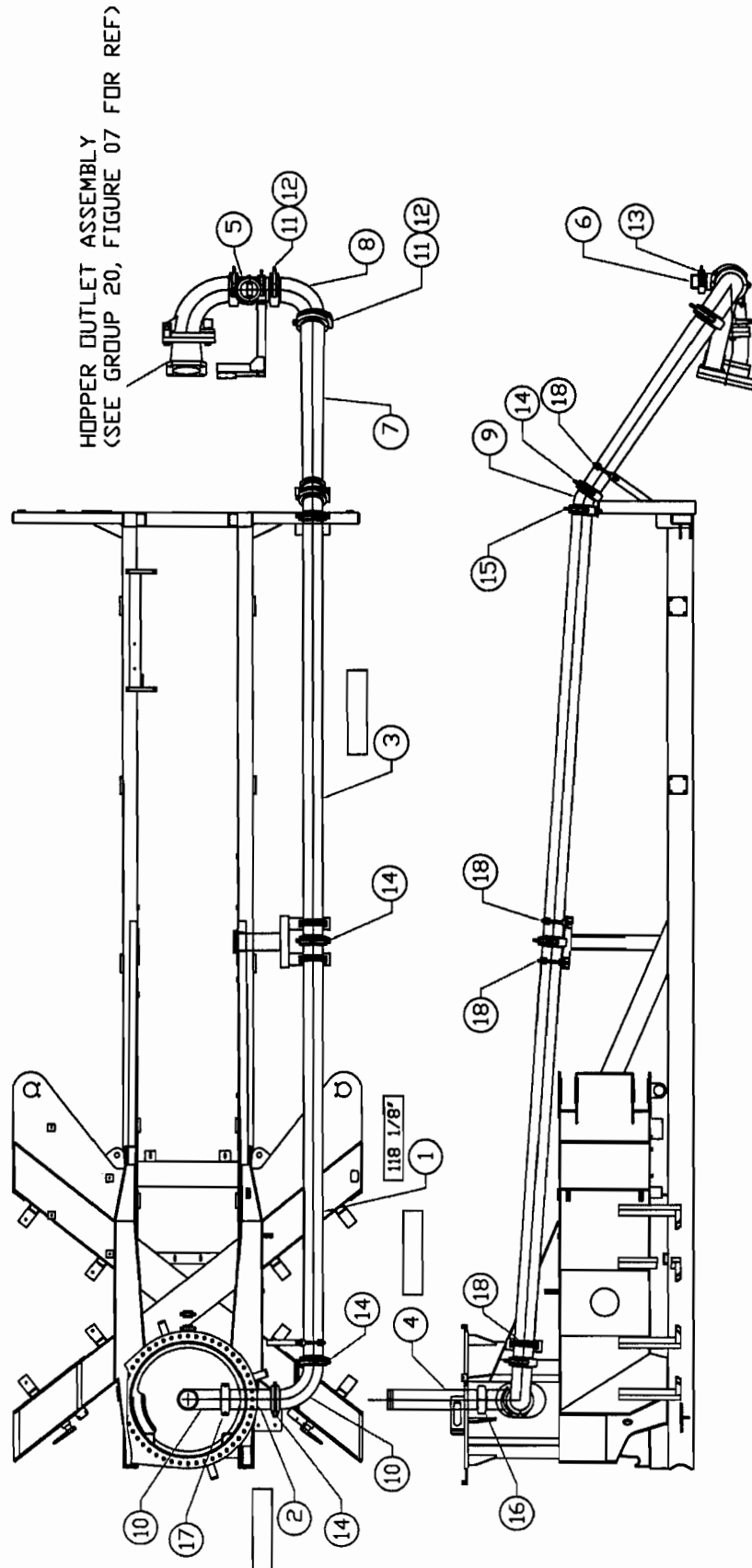

REVISION:

ITEM NO.	REED'S PARTS NO.	DESCRIPTION					QTY
		1	2	3	4	5	
	90-11	Assembly, Deck Delivery Line (See Group 90, Figure 01 for NHA)					Ref
1	801967-3000	• Deck Pipe, 3000mm					1
2	801967-305	• Deck Pipe, 305mm					1
3	801967-XXXX	• Deck Pipe, Makeup					1
4	801967-XXXX	• Deck Pipe, Makeup-Pedestal					1
5	801558	• Adaptor, Hopper Elbow					1
6	801565	• Cap Weldment					1
7	800326	• Reducer, 6" HP x 148mm					1
8	800336	• Elbow, 6" HP Male/Female					1
9	800328	• Elbow, 148mm x 30 Degree					1
10	800327	• Elbow, 148mm					2
11	72242	• Snap Coupling, 6" HP					1
12	72241	• Gasket, 6" HP					2
13	71530	• Snap Coupling, 4" HD					1
14	800070	• Snap Coupling, 148mm					4
15	802296	• Snap Coupling, 148mm w/Base					1
16	802291	• Two Bolt Coupling, 148mm					1
17	800068	• Two Bolt Coupling, 148mm w/Base					1
18	800341	• U-Clamp, 140mm					4
		DASH (-) ITEM NOT ILLUSTRATED					