



Model XT39R4

Truck Mounted 39-Meter Concrete Boom Pump



- **126'7" (38.6 m) Vertical Reach**
- **160 yd³/hr (125 m³/hr)**
- **1233 psi Concrete Pressure**
- **4-Section Roll and Fold Boom with 5" (125 mm) Line**
- **Centralized "X" Outrigger and Boom Pedestal**
- **Efficient Rexroth A4VG125 "Closed-Loop" Hydraulics**
- **Exclusively 90° Elbows on Boom**
- **Radiused Boom Design**

Boom: Versatile, compact, fully articulating 4-section roll-and-fold boom represents the latest in boom technology. Radiused boom design to improve durability and eliminate stress focal points. Low unfolding height of 29'10" (9.1 m).

Delivery Line: 5" (125 mm) delivery line, with straight pipe sections and 90 degree elbows.

Pedestal: Integrated outrigger and boom pedestal with small outrigger footprint. "X"-structure design eliminates stress or twist in truck frame. Hydraulic oil tank and water tank located in pedestal section for improved weight distribution. Two spacious 12' 9" (3.9 m) long decks for convenient storage of pipes and hoses.

Outriggers: Front and rear, fully hydraulic, "X"-type outriggers; only 22'4" (6.8 m) front width and 22'11" (7.0 m) rear width for quick setup. Front outriggers telescope while rear ones swing-out. Outrigger controls are located at the truck boom base. Unsurpassed stability while pumping.

Remote Controls: Fully proportional radio remote controls included. Convenient teathered back-up system. Manual boom controls are conveniently located on the RH side.

Clean-Out: Hydraulically driven, high pressure 580 psi (40 bar) water pump with a 185 gal (700 L) water tank and hose.

Concrete Pump - Closed-loop hydraulic system using Rexroth A4VG125 hydraulic pump for smooth, controllable pumping. Hard-chromed concrete cylinders and carbide wear parts precision machined for long life and tight sealing. Fully-variable volume control from 0 to 160 yd³/hr (0 to 125 m³/hr). Hinged clean-out door and swing away discharge pipe for quick, effective wash-out. All major system components located for good operator accessibility and ease of service. Harsh-mix hopper combines field proven boom pump experience with the most advanced technology available. Hopper grate and splash guards are standard.

Model XT39R4

Truck Mounted 39-Meter Concrete Boom Pump

BOOM SPECIFICATIONS		XT39R4	
Height & Reach			
Vertical Reach	126'7"	38.60 m	
Horizontal Reach	113'10"	34.70 m	
Reach Depth	87'11"	26.80 m	
Unfolding Height	29'10"	9.1 m	
4-Section Boom			
1st Section Articulation	100°	100°	
2nd Section Articulation	180°	180°	
3rd Section Articulation	180°	180°	
4th Section Articulation	240°	240°	
1st Section Length	30'6"	9.30 m	
2nd Section Length	27'7"	8.40 m	
3rd Section Length	27'7"	8.40 m	
4th Section Length	28'3"	8.60 m	
General Specs			
Pipeline Size (ID) Metric Ends	5.0"	125 mm	
Rotation	365°	365°	
End Hose: Length (Heavy-duty)	13'0"	4.00 m	
Diameter	5.0"	125 mm	
Outrigger Spread L-R-Front	22'4"	6.80 m	
Outrigger Spread L-R-Rear	22'11"	7.00 m	

PUMP SPECIFICATIONS			
Output:	160 yd ³ /hr	125 m ³ /hr	
Pressure:	1233 psi	85 bar	
Hard-Chromed Concrete Cylinders			
Concrete Cylinder Diameter	9.0"	230 mm	
Stroke Length	79.0"	2000 mm	
Maximum Strokes per Minute:	25		
Hopper Capacity	21.2 ft ³	600 L	
Volume Control	Zero to Full		
Hopper Grate Vibrator	Standard		
Hydraulic System:	Closed-loop		
Hydraulic System Pressure	4640 psi	320 bar	
Hydraulic Tank Capacity (Pump System)	116 gal	440 L	
Hydraulic Drive Cylinders: Rod Diameter	3.15"	80mm	
Piston Diameter	4.9"	125mm	
Water Tank Capacity	185 gal	700 L	
Maximum Aggregate Size	2.5"	63 mm	

TRUCK MOUNTED SPECIFICATIONS*		Truck Model: Mack MR 688S	
Horsepower	350	350	
Length	39'8"	12.08 m	
Width	8'6"	2.59 m	
Height	12'11"	3.94 m	
Wheelbase	215"	5.46 m	
Front Axle Weight (Approx.)**	19,374 lbs	8,806 kg	
Rear Axle Weight (Approx.)**	43,478 lbs	19,763 kg	
Total Weight (Approx.)**	62,852 lbs	28,569 kg	

Maximum theoretical performance shown above. Maximum output and pressure cannot be reached simultaneously. Performance will vary depending on slump, mix design and pipeline diameter. Specifications subject to change without prior notice.

*Dimensions vary with different truck makes, models and specifications.

**Weights are approximate and include pump, boom, truck, full hydraulic oil, full water tank, full fuel tank, and driver

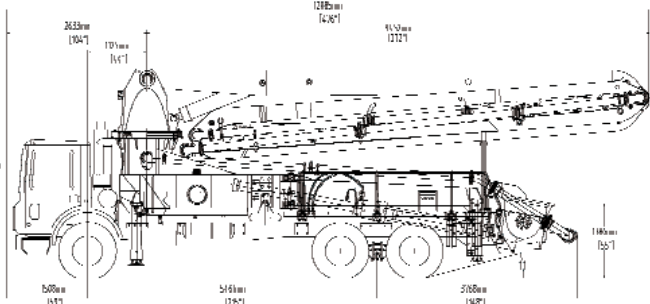
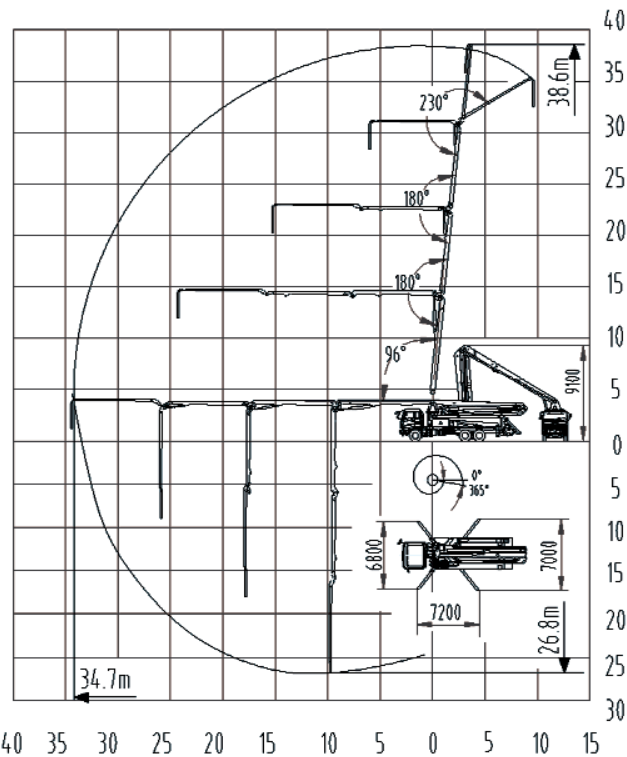

Distributed By:

REED • An Independent Member of the Shea Family of Companies
 13822 Oaks Avenue • Chino, California 91710-7008 USA • 909-287-2100
 Fax: 909-287-2140 • Toll-free: 888-779-7333 • www.reedpumps.com