



# M2200 MIXER TECHNICAL MANUALS

## Operations, Maintenance, Schematics, Parts, Safety



### OPERATIONS/ MAINTENANCE

- Introduction
- Warranty
- Safety
- Operation
- Main Controls
- Priming
- Pumping
- Clean-up
- Maintenance
- Check-List

### SCHEMATICS/ PARTS LISTS

- Pumping Train Group
- Power Train Group
- Main Hydraulic Pump
- Tanks
- Hydraulic Manifolds
- Accumulator
- Electrical Group
- PCL Controls
- Frame Installation
- Available Options

### SAFETY MANUAL AMERICAN CONCRETE PUMPING ASSOCIATION



- Introduction
- General Safety Rules
- Appendix



# OPERATION and MAINTENANCE



(909)287-2100

INTRODUCTION..... 2

WARRANTY ..... 2

    WARRANTY CLAIM FORM..... 4

SAFETY ..... 5

    SAFETY ALERT SYMBOLS AND SIGNAL WORDS..... 5

    LOCKOUT / TAGOUT..... 6

    GENERAL SAFETY GUIDELINES..... 6

    SAFETY DECALS ..... 8

OPERATION ..... 17

    OPERATOR QUALIFICATIONS ..... 17

    PRODUCT DESCRIPTION ..... 18

        B20HPC-RM POWER PACK..... 18

        RP2200 ELECTRIC POWER PACK ..... 19

    CONNECTIONS..... 20

CONTROLS ..... 22

    PAN MIXER CONTROL BOX..... 23

    RP2200 CONTROLS..... 24

JOBSITE SET-UP ..... 25

    PREPARING FOR SYSTEM START-UP..... 26

OPERATION OF PAN MIXER ..... 27

MAINTENANCE ..... 34

    RECOMMENDED MAINTENANCE PRACTICES..... 34

    GENERAL MAINTENANCE AREAS ..... 36

    LUBRICATION..... 37

    COMPONENT REPLACEMENT ..... 43

    PUMP MAINTENANCE SCHEDULE AND CHECKLISTS ..... 44

NOTES..... 51

REV	DATE	DESCRIPTION	NAME
RM2200-V04	11/06/19	REV*	J. SLACK



## INTRODUCTION

This manual introduces the warranty policy, safe operation, safe maintenance, parts, and other aspects of the concrete PAN MIXER.

Reading and understanding this operation manual will help maximize performance and reliability, and help minimize dangers, improper operation, and repair costs. Contact REED Customer Service for additional replacement manuals.

All safety guidelines, product descriptions, illustrations, and specifications found throughout this manual were in effect at the time the manual was released for printing. It should be noted; **REED RESERVES THE RIGHT TO MAKE CHANGES IN DESIGN OR TO MAKE ADDITIONS TO OR IMPROVEMENTS IN THE PRODUCT WITHOUT IMPOSING ANY OBLIGATIONS UPON ITSELF TO INSTALL THEM ON PRODUCTS PREVIOUSLY MANUFACTURED.**

Everyone involved with the operation, maintenance, inspection, and repair of the concrete pump **MUST READ** and **UNDERSTAND** this manual and the accompanying Safety Manual.



## WARRANTY

**REED** warrants each new M2200 Pan Mixer Concrete equipment to be free of defects in material and workmanship under normal use and service for a period as follows:

### PAN MIXER

- 1 year or 1200 operating hours, whichever occurs first
- All Structural Parts for 3 years

The warranty is issued **ONLY** to the **INITIAL USER**. The warranty period begins when the product is delivered to the initial user or when first put into service, whichever occurs first. Said warranty is void if the machine is subject to misuse, neglect, accident, and/or abuse.

**REED's** obligation under this warranty is limited to correcting without charge, at its factory, any parts or parts thereof which shall be returned to its factory, transportation prepaid and upon **REED's** examination proves to have been originally defective. Correction of such defects by repair or replacement shall constitute fulfillment of all obligations to the initial user. This warranty does not include labor or transportation charges unless specifically identified and authorized in writing by **REED**. Nor does the warranty apply to any unit upon which repairs or unauthorized alterations have been made.

This warranty does not apply to normal maintenance service or to normal replacement of certain machine parts which are subject to normal wear (such as concrete cylinders and wear components, valve mechanisms, delivery systems, hopper grate, etc.) **REED** makes no warranty in respect to trade accessories or outside vendor components, such being subject to the warranties of their respective manufacturers.

*THIS IS A LIMITED WARRANTY AND IS IN LIEU OF ANY OTHER WARRANTIES, EXPRESSED OR IMPLIED, INCLUDING ANY WARRANTY OF MERCHANTABILITY OF FITNESS FOR A PARTICULAR PURPOSE.* In no event shall **REED** be made liable for incidental, general or consequential damage, loss or any expense directly or indirectly related and resulting from use or lack of use caused by delay in delivery, parts failure, or any other causes associated with the product use. No person, firm or corporation is authorized to assume for **REED** any other liability in connection with the sale of **REED** products.

Effective April 2010



# OPERATION and MAINTENANCE



(909)287-2100

WARRANTY CLAIM FORM					
Claim Number:			Date:		
Distributor Account Number:			End User Account Number:		
Distributor:			End User:		
Address:			Address:		
City:	State:	Zip:	City:	State:	Zip:
Phone ( )			Phone ( )		
Pump Model: _____			In Service Date: _____		
Pump Serial Number: _____			Hours of Operation: _____		
			Failure Date: _____		
			Repair Date: _____		
<p>Do not send part(s) until requested by <b>REED</b> or until claim is approved. All parts requested to be returned must have a Return Authorization Number provided by <b>REED</b> and shipping freight prepaid. Parts must ship within 30 days from <b>REED</b> request.</p>					
Return Authorization Number:			Ship Date:		
Part Number	Description	Qty	Unit Price	Total Price	Replacement Part Invoice No.
Failure Description and Cause: _____					
<b>REED</b> Comments: _____					
Claim Value Approved:\$ _____			Claim Value Denied:\$ _____		
<b>REED</b> Print Name, Sign, and Date: _____					
Dealer Print Name, Sign, and Date: _____					

## SAFETY

Everyone involved with the operation, maintenance, inspection, and repair of the concrete pump **MUST READ** and **UNDERSTAND** this manual and the accompanying Safety Manual.

### SAFETY ALERT SYMBOLS AND SIGNAL WORDS

The following safety alert symbols, signals, and explanations are intended to warn the operator of hazardous and potentially hazardous situations.

The triangle with the exclamation point inside is used to alert the operator to an important safety point and is called a safety alert symbol. One of the following signal words will appear after the safety alert symbol:



If the safety alert symbol is followed by the signal word **DANGER**, the safety alert symbol indicates a hazardous situation which, if not avoided, **WILL** lead to death or serious injury.

If the safety alert symbol is followed by the signal word **WARNING**, the safety alert symbol indicates a potentially hazardous situation which, if not avoided, **COULD** result in death or serious injury.

If the safety alert symbol is followed by the signal word **CAUTION**, the safety alert symbol indicates a potentially hazardous situation which, if not avoided, **COULD** result in minor to moderate injury.

The signal word **CAUTION**, but without safety alert symbol means the safety symbol alert addresses a hazard which, if not avoided, **COULD** cause damage to equipment or property.

### LOCKOUT / TAGOUT

The Lockout/Tagout procedure applies to all **REED** concrete placing equipment. Before performing any maintenance and/or repair on equipment;

1. Remove keys lock-out signage must be posted to indicate machine is currently under Lockout/Tagout.

The following symbol is a reminder to Lock Out and Tag Out equipment before working on equipment.

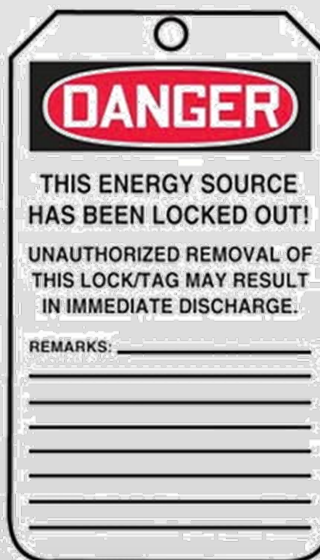

---

## GENERAL SAFETY GUIDELINES

**WARNING**

Use Only Qualified, Experienced, and Trained Personnel  
Wearing Protective Equipment At All Times

**WARNING**

For Safe Use, Maintenance, Inspection, and Repair,  
Only Operate, Maintain, Inspect, and Repair  
In Accordance with This Operation Manual and the Safety Manual

**WARNING**

Performance and Safety Features Must Never Be Altered, Disconnected, or Removed

**WARNING**

Contact **REED** Technical Support and Service When Assistance Is Required

**SAFETY DECALS**

Decals and placement of decals are standardized by the Concrete Pump Manufacturers Association (CPMA) for your protection. They are placed at appropriate areas on the concrete pump to be constant warnings of dangers. Know and adhere to the information they provide. Contact **REED** Customer Service for complimentary replacements of safety decals, shipping charges may apply.

**DECALS PLACED NEAR CONTROL BOX AREA**

**WARNING**  
Do not operate at pressure exceeding the rating of the entire mechanical delivery system.

**ADVERTENCIA**  
No operar a presiones que excedan la presión nominal de todo el sistema mecánico de entrega.

**WARNING**  
Do not use the boom as a crane or hoist.

**ADVERTENCIA**  
No usar la palanca como grúa o aparato de levanta.

**WARNING**  
Stay off hopper grates.

**ADVERTENCIA**  
Manténgase siempre en la rejilla que cubre la tolva.

**⚠ WARNING**

**Do not operate this machine without training. Understand the warnings in safety manuals and on decals.**

**⚠ ADVERTENCIA**

**No use esta maquinaria sin estar capacitado. Entienda las advertencias de los manuales de seguridad y de las calcomanías.**

Do not paint over this label/No pintar encima de ésta etiqueta

800925

<b>IMPORTANT</b>	<b>IMPORTANTE</b>
<p>You can order additional operation manuals, spare parts books, safety manuals and decal sets by contacting us at:</p> <p>REED Manufacturing 1-(888)-779-7333 7:00 AM to 5:00 PM Pacific Time Monday through Friday</p>	<p>Usted puede solicitar manuales de operacion, catalogos de refacciones, manuales de seguridad y juegos de calcomanias adicionales contactando a:</p> <p>REED Manufacturing 1-(888)-779-7333 DE 7:00 AM a 5:00 PM Hora Pacifico LUNES A VIERNES</p>

Do not paint over this label/No pintar encima de ésta etiqueta

803226





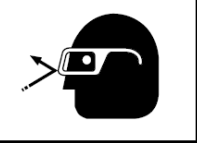

---

**DO NOT OPERATE  
MACHINE  
WITHOUT ALL  
GRATES IN PLACE**

⚠ WARNING			SAFETY INSTRUCTIONS	
			<ol style="list-style-type: none"> <li>1. Relieve system pressure before opening any system or coupling.</li> <li>2. Regularly inspect system condition and wall thickness.</li> <li>3. Wear reduces system burst pressure.</li> <li>4. Use recommended clean out procedures - consult manufacturer.</li> <li>5. Use retaining pins in delivery system snap couplings.</li> </ol>	
<ul style="list-style-type: none"> <li>• Stay clear of pressurized concrete placing system.</li> <li>• Wear eye protection.</li> <li>• Do not operate at pressures exceeding the rating of any piece of the material delivery system.</li> </ul>			INSTRUCCIONES DE SEGURIDAD	
<p><b>⚠ ADVERTENCIA</b></p> <ul style="list-style-type: none"> <li>• Permanezca alejado del sistema de distribución de concreto presurizado.</li> <li>• Use protección para los ojos.</li> <li>• No opere a presiones mayores que las de la capacidad de cualquier pieza del sistema de descarga.</li> </ul>			<ol style="list-style-type: none"> <li>1. Alivie la presión del sistema ante de abrir un sistema o un acoplamiento.</li> <li>2. Inspeccione periódicamente el estado del sistema y el espesor de las paredes.</li> <li>3. El desgaste reduce la presión de rotura por estallido.</li> <li>4. Use los procedimientos de limpieza recomendados, consulte con el fabricante.</li> <li>5. Use los pasadores de retención en los acoplamientos de fijación a presión.</li> </ol>	

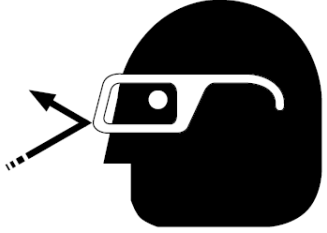
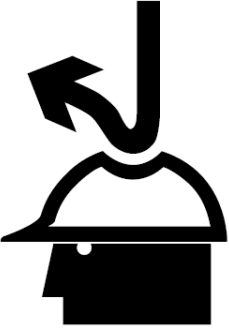
803237

ADVERTENCIA ⚠ WARNING		
		
Do not paint over this label/No pintar encima de ésta etiqueta		

800929A

INSTRUCCIONES DE SEGURIDAD				SAFETY INSTRUCTIONS		
 <p>Recommended hand signals Señales de mano recomendadas</p>						
						
1. START PUMP SPEED UP	2. SLOW PUMP DOWN	3. STOP PUMP	4. LITTLE BIT	5. RELIEVE PRESSURE (2 golpecitos) (2 taps)	6. ADD WATER 4-GALLONS	7. ALL DONE CLEAN UP
1. PRENDER LA BOMBA ACELERAR	2. BAJAR VELOCIDAD A LA BOMBA	3. PARAR LA BOMBA	4. UN POCO	5. ALIVIAR LA PRESIÓN	6. AÑADIR AGUA 4-GALONES	7. TERMINADO LIMPIAR
Do not paint over this label/No pintar encima de ésta etiqueta						

803235

### DECALS PLACED NEAR HOPPER GRATE AREA

Do not paint over this label/No pintar encima de esta etiqueta

**⚠ WARNING**



Keep hands out of hopper and valve assembly. See operation manual if access is required.

**⚠ ADVERTENCIA**

No meta las manos a la tolva o válvula. Consulte el manual de operación si necesita tener acceso.

800917

Do not paint over this label/No pintar encima de esta etiqueta

**⚠ WARNING**



Stay off hopper grates.

**⚠ ADVERTENCIA**

Manténgase alejado de la rejilla que cubren la tolva.

800918

Do not paint over this label/No pintar encima de esta etiqueta

**! WARNING**



**Cement dust is toxic. Use lung protection when exposed.**

**! ADVERTENCIA**

**El polvo de cemento es tóxico. Use protección para los pulmones cuando se exponga.**

803231

### DECALS PLACED NEAR WATERBOX AREA

	 <b>WARNING</b>
	<b>Keep hands out of waterbox. Stop motor if access is required. Keep guards in place.</b>
	 <b>ADVERTENCIA</b>
	<b>No meta las manos a la caja de agua. Pare el motor si necesita tener acceso. Mantenga las cubiertas cerradas.</b>

Do not paint over this label/No pintar encima de ésta etiqueta

800916

### DECALS PLACED NEAR OUTRIGGER CONTROL AREA

	 <b>WARNING</b>
	<b>Clear area before activating outriggers.</b>
	 <b>ADVERTENCIA</b>
	<b>Despeje el área antes de activar los estabilizadores.</b>

Do not paint over this label/No pintar encima de ésta etiqueta

800919

### DECALS PLACED ON SIDE PANEL AREA



#### **⚠ WARNING**

This machine is remote controlled and may start at any time. Stop engine before servicing unit.

#### **⚠ ADVERTENCIA**

Esta máquina funciona a control remoto y puede ponerse en marcha en cualquier momento. Apagar el motor antes de realizar el mantenimiento.

Do not paint over this label/No pintar encima de esta etiqueta

800921

#### **⚠ WARNING**

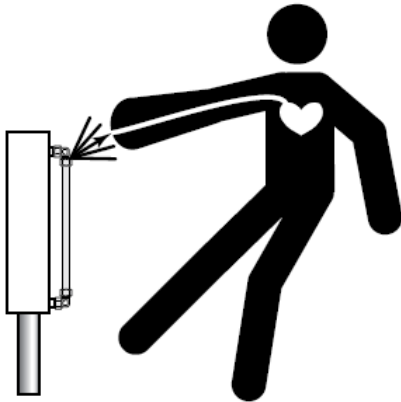

Do not paint over this label/No pintar encima de esta etiqueta

Do not touch hydraulic oil leaks. Get immediate medical attention if oil penetrates skin.

#### **⚠ ADVERTENCIA**

No toque las fugas de aceite hidráulico. Obtenga atención médica inmediata si el aceite penetra en la piel.

803225



800931







## OPERATION

### OPERATOR QUALIFICATIONS

**Everyone involved with the operation, maintenance, inspection, and repair of the concrete pump MUST READ and UNDERSTAND this operation manual and the accompanying Safety Manual.**

The following are a few general warnings for operator qualifications outlined in the Safety Manual.



- Individuals who cannot read and understand this operation manual, Safety Manual, signs, warnings, notices, and operating instructions, in the language in which they are printed, must not be allowed to operate the concrete equipment / mixer.
- Only qualified, experienced, and trained personnel may be allowed to operate the concrete equipment / mixer.
- Operation, maintenance, inspections, and repair must only be made by qualified, experienced, and trained personnel.
- Obey all applicable local and government statutes and regulations applying to safely operate equipment in their location.

### PRODUCT DESCRIPTION

The operation of the pan mixer encompasses the use of hydraulic and electrical systems. The pan mixer is designed to safely mix wet concrete or material within its published ratings and specifications.

Stability of the pan mixer during operation is provided by the (4) adjustable legs that can be raised or lowered manually to accommodate terrain.

**REEDs powerful M2200 Pan Mixer can mix a 3000 lb. batch of shotcrete / concrete materials.** The M2200 will mix a 1-ton super sack (2200 lbs.) of material in 3 minutes. The mixer then quickly discharges the material into the pump hopper to be either sprayed or pumped.

The M2200 features:

**(OPTION)  
Variable Speed  
Mixer Blade  
Rotation**

**Hydraulic Motor  
drive,59 rpm  
maximum,**

**Forklift tubes and  
lifting eye kit for  
easy transport**

**Manual  
retractable (4)legs**

**(OPTION)  
Stainless steel or  
plastic water tank  
for precise water  
measurements**

**Work platform  
with controls and  
safety railing**

**Heavy duty  
Bag splitter**

**Safety grate cover with shut-off**

**Nema 4  
fully enclosed  
weather prof  
control panel  
mounted on  
operator  
platform**

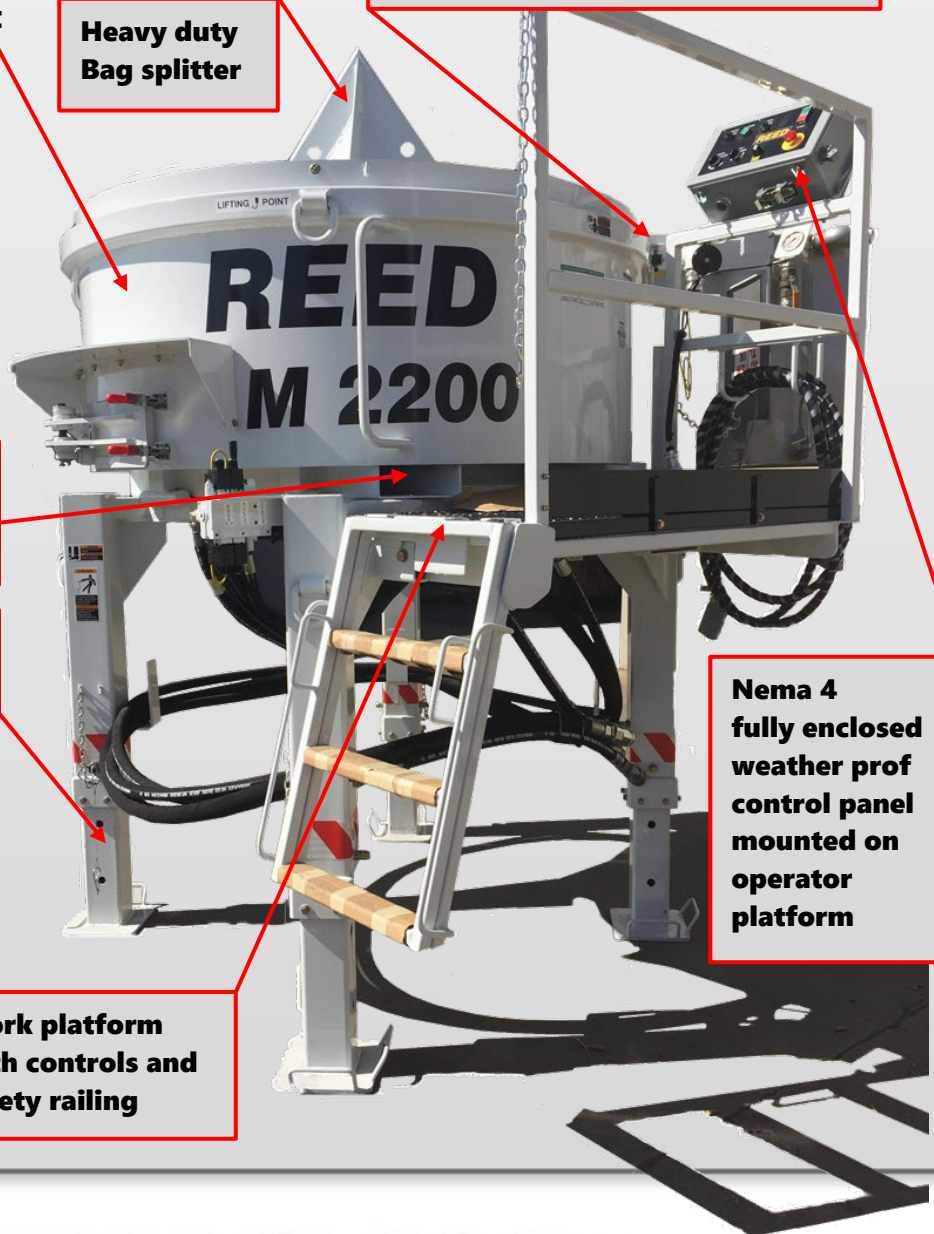

### B20HPC-RM POWER PACK

The M2200 Pan Mixer can also be powered by B20HPC-RM Hydraulic Power Pack (sold separately). Power Pack information is as follows:

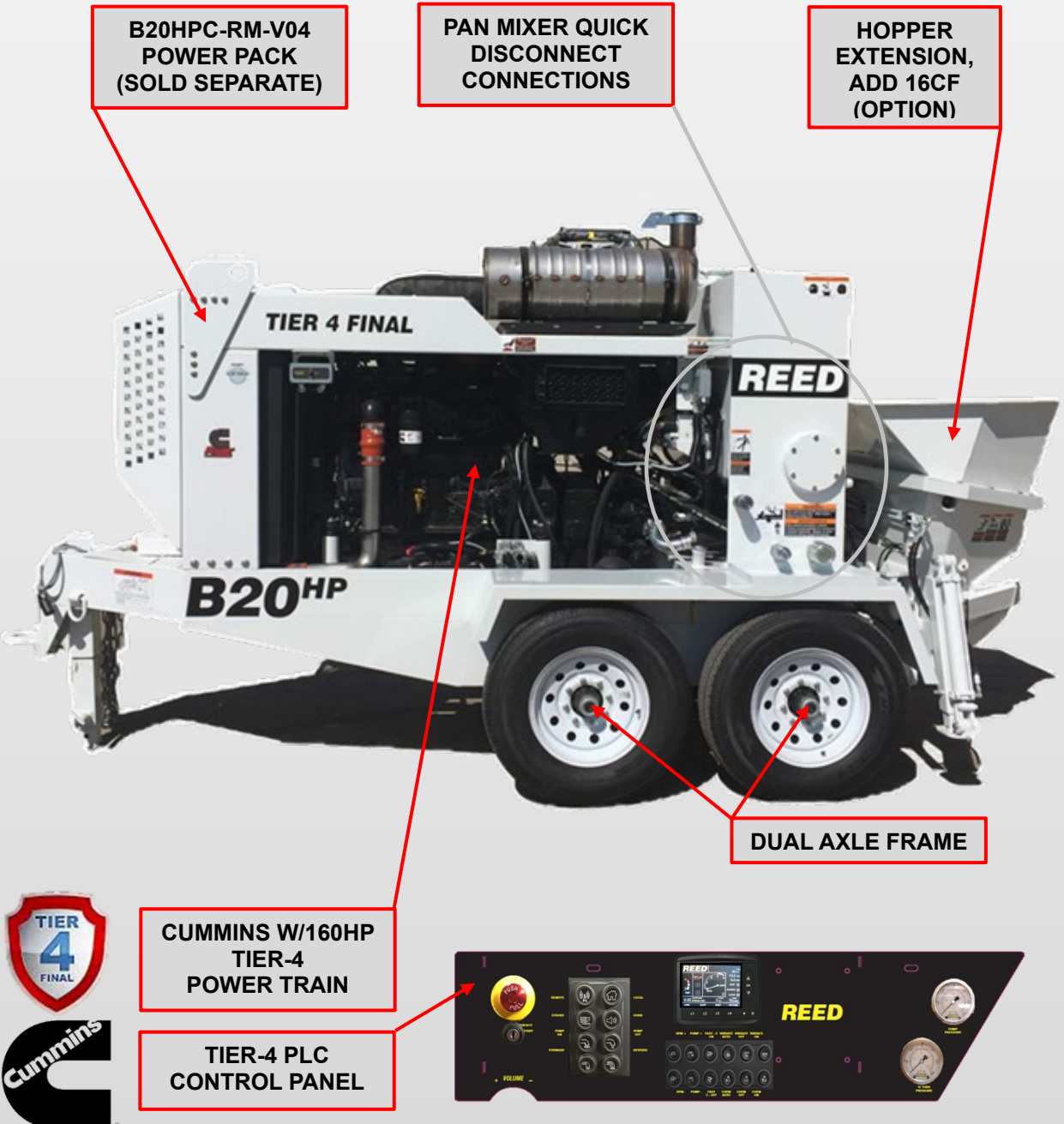

### CONNECTIONS

1. HYDRAULIC HOSES BETWEEN THE POWER PACK AND PAN MIXER
  - THERE ARE HIGH PRESSURE HOSES THAT MUST BE INSTALLED BETWEEN POWER PACK AND PAN MIXER. THE ENDS ARE SPRING LOADED. THE ENDS ARE MALE AND FEMALE AND DIFFERENT SIZES, THERE SHOULD BE NO CONFUSION OF PLACEMENT INSTALLATION.



**! DANGER**

**CAUTION**

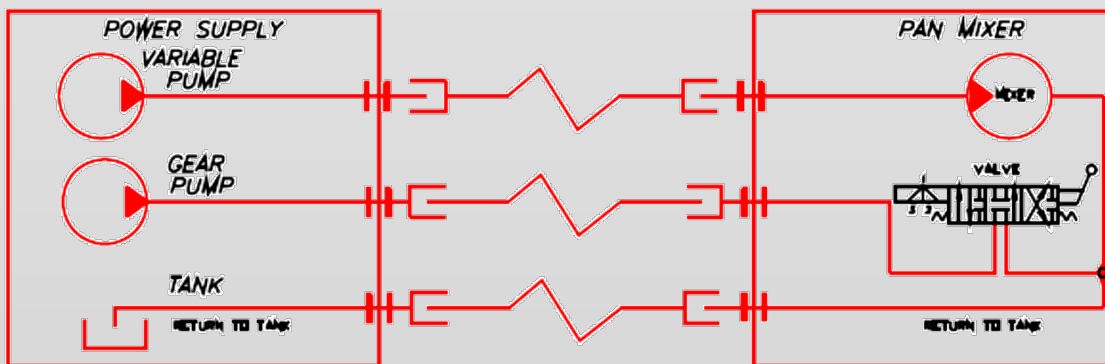



### CONNECTIONS

2. ELECTRICAL CONNECTION BETWEEN PAN MIXER AND POWER PACK
  - THERE IS A COMUNICATION CABLE THAT MUST BE CONNECTED BETWEEN THE POWER PACK AND THE PAN MIXER. THIS 24 CONDUCTOR CABLE CARRIES ALL INFORMATION AND POWER BETWEEN THE MIXER AND POWER PACK. IT CONSISTS OF MALE AND FEMALE ENDS THAT ARE SELF EXPLANATORY WHEN VIEWED STRAIGHT ON FROM THE END.



CONNECT  
COMMUNICATION CABLE  
TO POWER PACK  
  
THEN TO CONTROL  
PANEL



**CONTROLS****PAN MIXER CONTROL BOX**

1. **System ON/OFF** (Green Rotary Switch w/light)
  - SWITCH POSITION TO THE LEFT = OFF CONDITION
  - SWITCH POSITION TO THE RIGHT = CONTROL ON LIGHT SHOULD COME ON
2. **Horn Switch** (Green Button)
  - WHEN PUSHED THE HORN SHOULD SOUND AND THE RED 'E' STOP LIGHT SHOULD STOP FLASHING (Note, the MOTOR SWITCH MUST BE IN THE OFF POSITION)
3. **Mixer Paddle ON/OFF** (Green Rotary Switch w/light)
  - THIS SWITCH IN THE "ON" POSITION WILL START THE MIXER PADDELS TURNING AS LONG AS THE LIGHT IS NOT FLASHING. IF FLASHING THE SYSTEM IS IN AN "E" STOP CONDITION AND "MUST" BE RESET, BY CLEARING THE FAULT TURNING OFF THE "MOTOR" SWITCH AND THEN SOUNDING THE HORN, AT THIS POINT THE SYSTEM SHOULD BE READY. (Note if using an electric power pack, the motor must be restarted)
4. **I-O (START (green)-STOP (red)) PUSH BUTTON SWITCH**
  - THIS PUSH BUTTON SWITCH IS MEANT TO START AND STOP THE 50Hp. ELECTRIC MOTOR OF THE POWER PACK. IT HAS AN OPORATIONAL LIGHT TO SIGNAL START. 'I' = START AND 'O' = STOP.

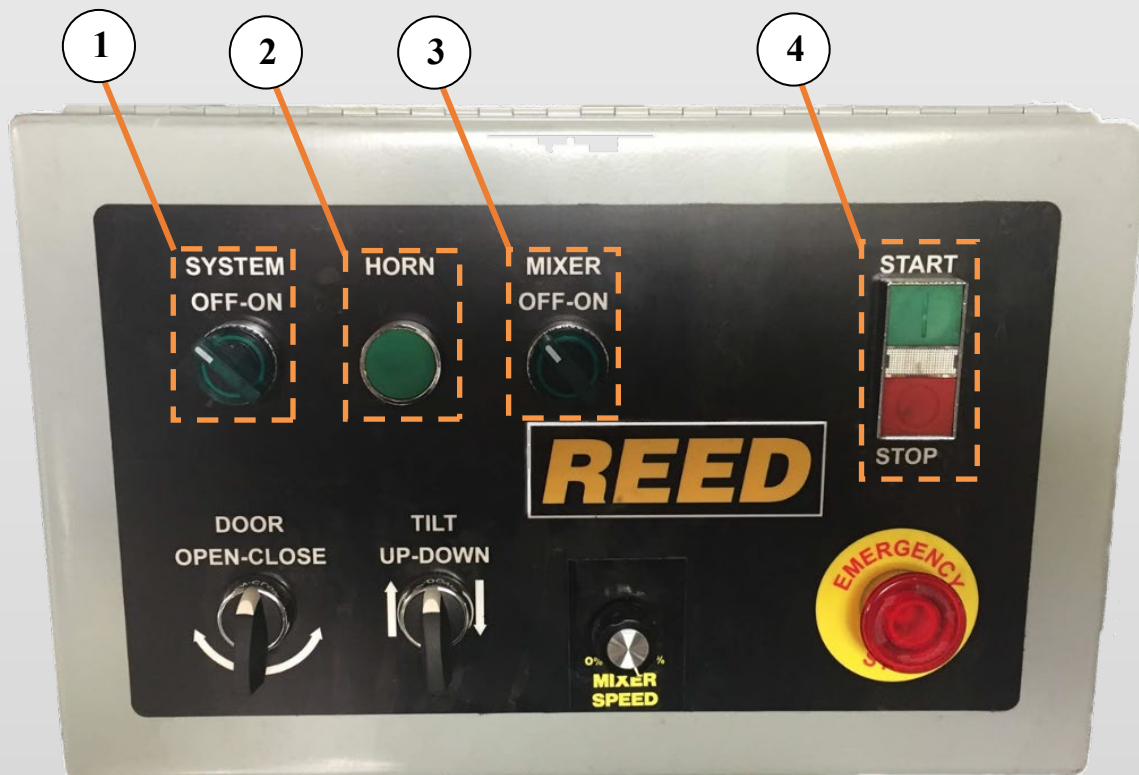



**PAN MIXER CONTROL BOX****5. EMERGENCY STOP (LARGE RED PALM BUTTON)**

- THIS LARGE RED PALM BUTTON IS A PUSH TO ACTIVATE THEN TWIST AND PULL UP TO START THE RESET SEQUENCE. THIS BUTTON SHUTS OFF ALL FEATURES OF THE PAN MIXER AND WHEN HOOKED TO AN ELECTRIC POWER PACK SHUTS DOWN THE ELECTRIC MOTOR. THIS SWITCH HAS A RED LIGHT THAT BLINKS ON/OFF WHEN DEPRESSED TO LET YOU KNOW THAT IT HAS BEEN ACTIVATED. (TWIST AND PULL UP TO START THE RESET SEQUENCE).

**6. DOOR SWITCHES**

- THE CALL OUT IS 'DOOR OPEN- CLOSE' THESE SWITCHES ARE SPRING CENTERED AND THE LEGENDS ABOVE AND BELOW THEM CALL OUT THE DIRECTION OF ROTATION THAT WILL BE ACHIEVED FROM THE ACTIVATION OF THIS ROTATION (The switches are momentary and not proportional to their movement only ON-OFF-ON in there nature)

**7. TILT UP-DOWN**

- THIS ROTARY SWITCH IS TO ACTIVATE THE TILT SYSTEM OF THE PAN MIXER TO DUMP OUT OF ONLY ONE DOOR DURING CLEAN OUT OR IF THERE IS A PROBLEM WITH THE MIX.

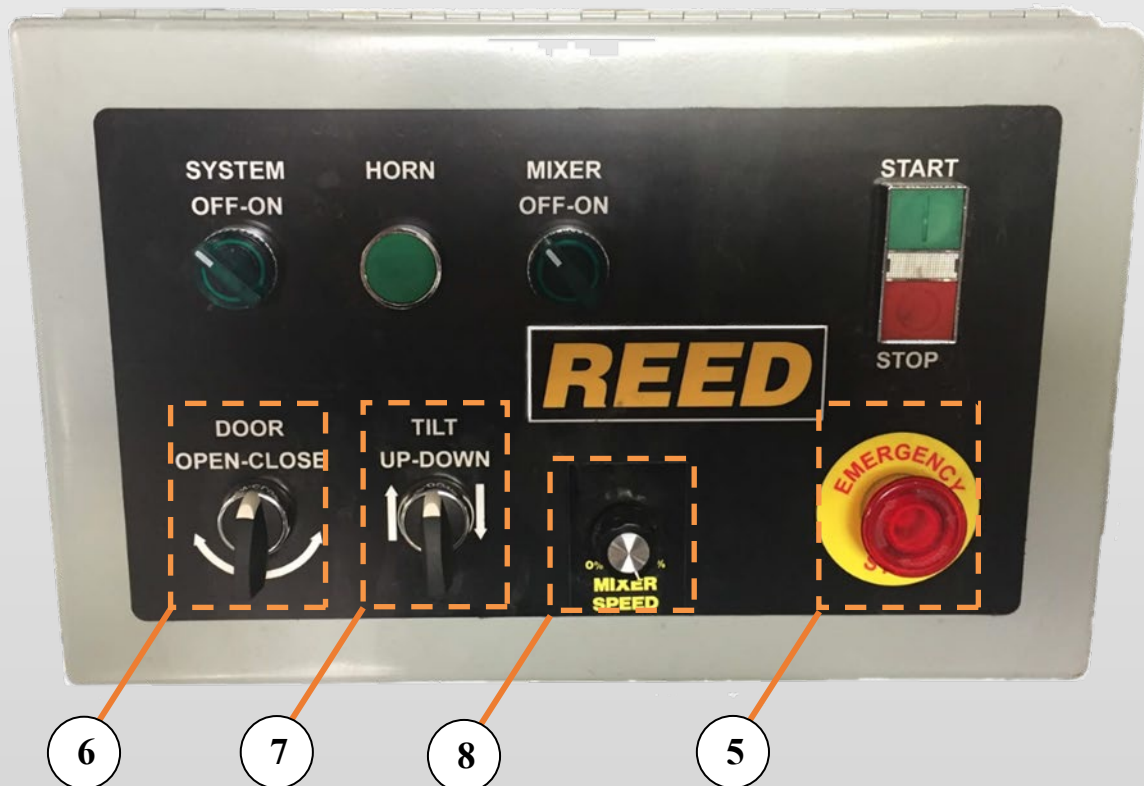
**8. MIXER SPEED CONTROL KNOB THIS ROTARY SWITCH IS TO ADJUST BLAD MIXER SPEED**

### RP2200 CONTROLS

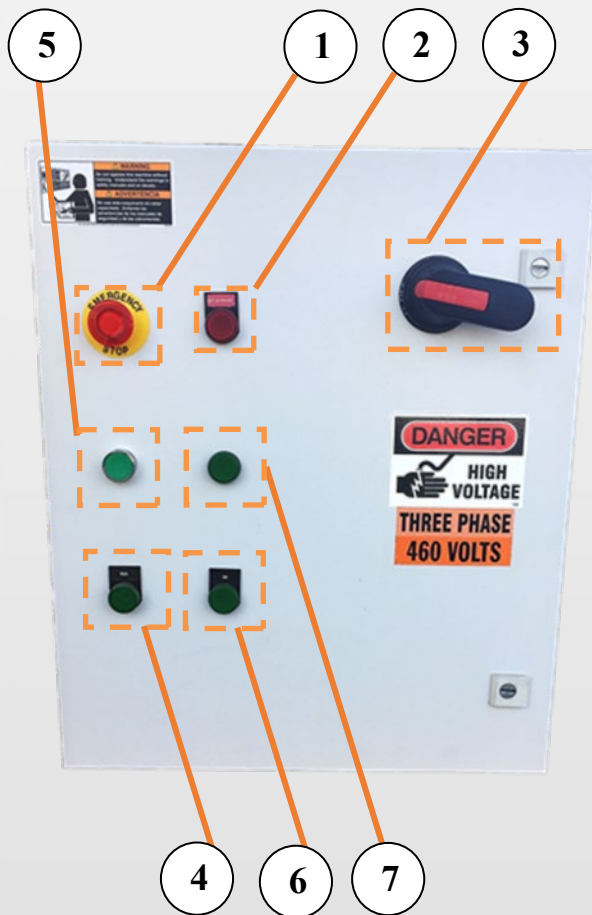

1. EMERGENCY STOP (LARGE RED PALM BUTTON)
  - THIS LARGE RED PALM BUTTON IS A PUSH TO ACTIVATE THEN TWIST AND PULL UP TO START THE RESET SEQUENCE. THIS BUTTON SHUTS OFF ALL FEATURES OF THE PAN MIXER AND WHEN HOOKED TO AN ELECTRIC POWER PACK SHUTS DOWN THE ELECTRIC MOTOR. THIS SWITCH HAS A RED LIGHT THAT BLINKS ON/OFF WHEN DEPRESSED TO LET YOU KNOW THAT IT HAS BEEN ACTIVATED. (TWIST AND PULL UP TO START THE RESET SEQUENCE).
2. OUT OF PHAZE LIGHT (RED)
  - THIS LIGHT IS ILLUMINATED AFTER START UP AND SHOULD GO OFF IMMEDIATELY, IF IT DOES NOT TURN OFF THEN THERE IS A THREE PHAZE INCOMING POWER ISSUE AND IF NOT DEALT WITH WILL NOT ALLOW THE ELECTRIC MOTOR TO RUN (Note, consult a licensed electrician for testing and repair of condition, consult factory for any added assistance)
3. MAIN POWER DISCONNECT LEVER
  - THIS LEVER IS A ONE QUARTER TURN HANDLE THAT WILL ALLOW THE CONTROLS TO BE POWERED DOWN INTERNALLY EXCEPT FOR THE MAIN WIRES COMING FROM THE MAIN POWER SUPPLY. CONTROL BOX DOOR CAN BE OPENED AND ACCESS THE COMPONENTS INSIDE FOR SERVICE. (Note, only licensed electricians should be allowed inside of control box 'THE POSSIBILITY OF DEATH CAN OCCUR').
4. RUN LIGHT (Green)
  - THE RUN LIGHT WILL ILLUMINATE WHEN THE MAIN ELECTRIC MOTOR HAS BEEN SUCCESSFULLY STARTED.
5. Horn Switch (Green Button)
  - WHEN PUSHED THE HORN SHOULD SOUND ADVISING WORKERS OF A NEW CONDITION.
6. MOTOR ON LIGHT (green)
  - LIGHT WILL ILLUMINATE WHEN THE MAIN ELECTRIC MOTOR IS IN THE RUNNING CONDITION
7. READY LIGHT
  - LIGHT WILL BE ILLUMINATE WHEN READY TO START MIXER.

## JOBSITE SET-UP

Refer to the Safety Manual for set-up safety precautions not limited to the following guidelines:

### **WARNING**

Ensure Machine Can Be Safely Operated in Set-Up Location  
Away from Hazards and Dangers  
Away from Slopes and Excavations

### **WARNING**

Position Machine on As Solid and Level Ground As Possible

### **WARNING**

Adjust height of Machine and remove Leg pins

### **WARNING**

Secure Machine Positions with Leg Pins and Locks

### PREPARING FOR SYSTEM START-UP

When Removing Leg Pins Making sure there are no objects underneath mixer or platform.

**CAUTION**

THE STEPS ARE A MANUAL TYPE THAT RAISE UP TO UNLATCH AND THE CAN BE LOWERED TO ADDAPT TO THE PAN HIGHTH BY HOOKING THE TOUNGE TO THE CORRECT RUNG FOR THE JOB SITE.

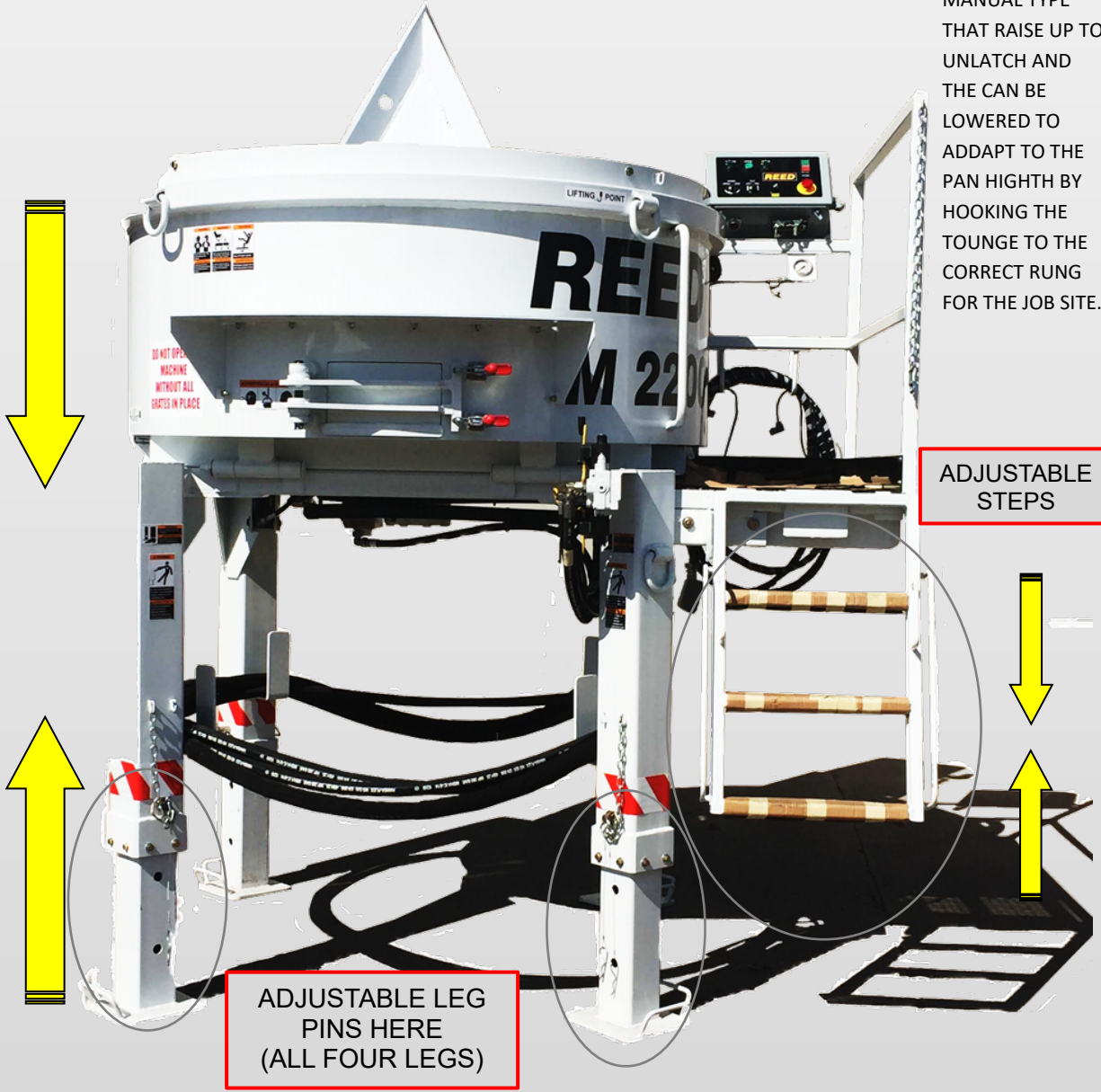

### OPERATION OF PAN MIXER

#### PREPARING FOR SYSTEM START-UP

AFTER ALL CONNECTIONS HAVE BEEN MADE AND THE APPROPRIATE POWER HAS BEEN SUPPLIED TO THE CONTROL BOX THE LICENSED ELECTRICIAN CAN TEST FOR PROPER ROTATION OF THE ELECTRIC MOTOR AND ALL SUPPORTING CONNECTIONS.

THE OPERATOR SHOULD FAMILIARIZE HIMSELF WITH THE CONTROLS AND LOCATION OF HIS FEET TO BE SAFE ON THE DECK.



**THE HOPPER GRATE MUST BE CLOSED** (There is a safety interlock that guards against the opening of the mixer grate there will be more on this later)

#### SYSTEM START-UP

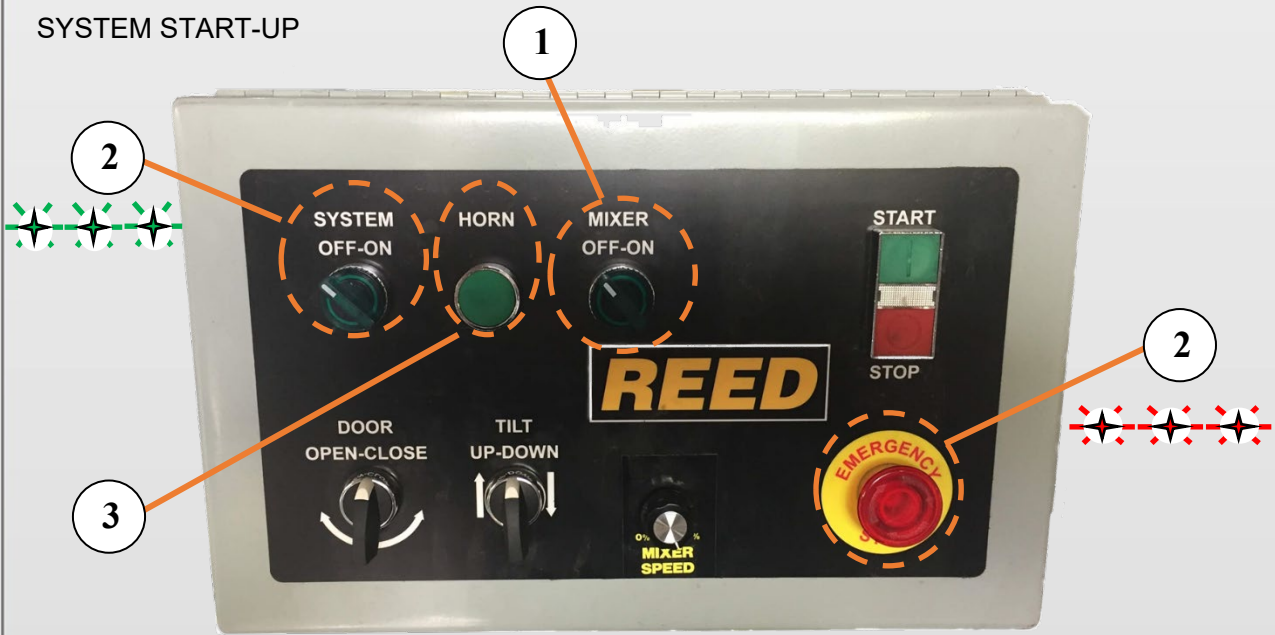

1. THE **MIXER SWITCH** MUST BE IN THE **OFF POSITION**. THEN THE **SYSTEM SWITCH** CAN BE TURNED ON.
2. TURN ON THE **SYSTEM ON-OFF SWITCH** TO **"ON"** THE LIGHT IN THE SYSTEM ON SWITCH WILL BE FLASHING ALONG WITH THE 'E' STOP LIGHT.
3. THE **HORN SWITCH** MUST BE **"PRESSED"** TO ALERT WORKERS IN THE AREA OF A CHANGE IN CONDITION THAT COULD BE LIFE THREATENING, AND THE LIGHTS SHOULD STOP FLASHING AND GO TO A CONSTANT ON CONDITION. IF THIS DOES NOT HAPPEN THERE IS A PROBLEM IN THE SYSTEM THAT MUST BE ADDRESSED. (I.E. hopper open, motor switch on, poor connection somewhere.)

READY CONDITION "SOLID LIGHT"



E-STOP CONDITION "FLASHING LIGHT"



## OPERATION OF PAN MIXER

### SYSTEM START-UP

4. THE ELECTRIC MOTOR MAY BE STARTED FROM THE PLATFORM WITH THE I-O (**START** (green)-**STOP** (red)) PUSH BUTTON SWITCH. BY PUSHING THE GREEN BUTTON.
  5. ONCE ELECTRIC MOTOR IS STARTED YOU SHOULD SEE HYDRAULIC PRESSURE ON THE GADGE.
- TURN **MIXER SWITCH** TO THE "ON" POSITION.
6. **MIXER SPEED** CAN BE CONTROLLED BY ROTORY KNOB.

IN THE CASE OF THE END OF THE DAY OR IF THERE IS A STOP IN PRODUCTION THE RED BUTTON CAN BE PUSHED TO STOP THE ELECTRIC MOTOR, AS ALWAYS, THE MIXER MOTOR SHOULD BE STOPED FIRST.

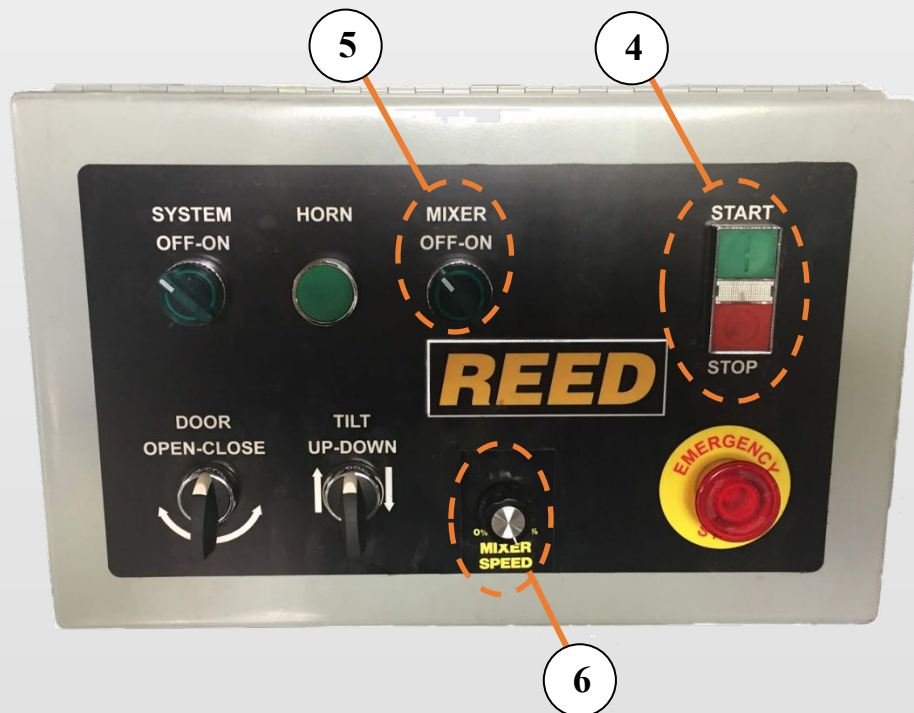

AFTER BLENDING MATERIAL IN MIXER, THERE MAY BE A NEED FOR A SAMPLE OF THE BLENDED MATERIAL, IN THIS CASE THE HOPPER GRATE CAN BE RAISED WITH OUT STOPING THE MOTOR DRIVING THE BLADES FOR A PERIOD OF TIME EQUAL TO 30 SECONDS ONLY! AFTER THAT TIME PERIOD THE MACHINE WILL DEFAULT TO THE 'E' STOP CONDITION.

THE OPOPERATOR AND ALL FUNCTIONS INCLUDING THE ELECTRIC MOTOR WILL BE SHUT OFF. YOU MUST RESTART THE COMPLETE SYSTEM.

DURING THE OPERATION OF THE MACHINE DURING THE DAY, AS LONG AS THE BLADE **MOTOR SWITCH** IS IN THE "OFF" POSITION THE HOPPER GRATE CAN BE LIFTED OPENED WITH OUT THE POSSIBILITY OF 'E' STOP CONDITION ENGAGMENT.

### OPERATION OF PAN MIXER

7. **EMERGENCY BUTTON SWITCH** CAN BE PRESSED IN THE CASE OF AN EMERGENCY. RED BUTTON CAN BE PUSHED TO STOP THE MIXER, OR IF THE HOPPER GRATE IS LIFTED OPEN OVER 30 SECONDS IT WILL GO TO E-STOP



IF **EMERGENCY BUTTON** IS PRESSED, OR IS IN THE E-STOP MODE THE RED LIGHT WILL BE FLASHING "RED"

#### HOW TO RESET **EMERGENCY STOP BUTTON**

8. AFTER PUSHING THE **E-STOP BUTTON** YOU MUST TURN THE RED BUTTON TO THE RIGHT TO RESET THE BUTTON. THEN YOU MUST PLACE THE **MIXER SWITCH** IN THE "OFF" POSITION

THE **HORN** SWITCH MUST BE "PRESSED" TO RESET SYSTEM

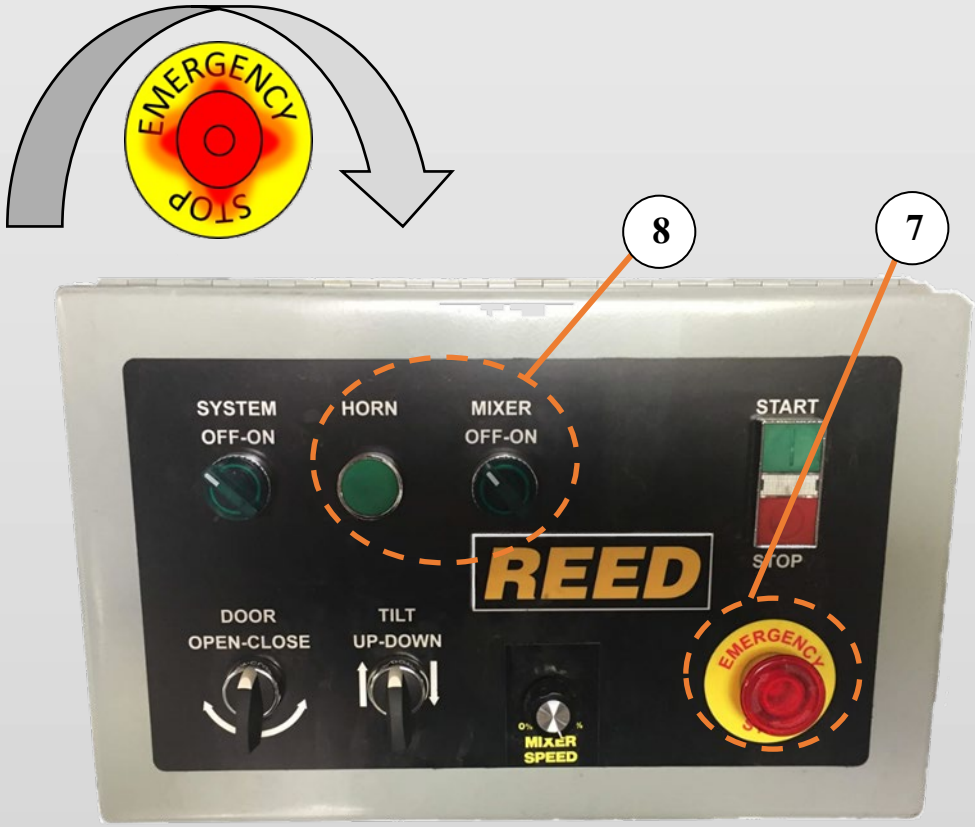



### OPERATION OF PAN MIXER

#### SUB SYSTEMS DOORS-TILT-WATER PUMP

- ALL THE FUNCTIONS OF THE SUB SYSTEMS EXCEPT FOR THE WATER PUMP CAN BE RUN FROM THE PLATFORM WITH THE PREVIOUSLY MENTIONED SWITCHES, ALSO ALL THE FUNCTIONS INCLUDING THE WATER PUMP CAN BE MANUALLY RUN FROM THE VALVE ASSEMBLY ON/OFF NOT A FRICTION TYPE AT THE BASE OF THE STEPS.
- THE WATER PUMP IS A HIGH-PRESSURE SYSTEM THAT CAN BE USED FOR ROUTINE CLEANING.
- INPUT FLOW TO THE WATER PUMP IS A STANDARD GARDEN HOSE HOOK UP.

9. HOW TO OPERATE **HYDRAULIC DOOR**, THE CALL OUT IS “DOOR OPEN-CLOSE” THE SWITCH ARE SPRING CENTERED. TURN TO THE LEFT TO “OPEN” TURN TO THE RIGHT TO “CLOSE”.

HOW TO OPERATE **CLEAN-OUT DOOR**, THE DUMP DOOR IS A MANUAL TYPE. UNLOCK THE LUCKS AND OPEN THE DOOR MANUAL, THEN LIFT MIXER UP FOR CLEAN OUT.

### CAUTION

10. “**CAUTION**” HOW TO OPERATE THE TILT SWITCH, TO CLEAN-OUT OR DUMP MATERIAL, TURN THE **TILT SWITCH** TO THE LEFT TO LIFT. TURN THE **TILT SWITCH** TO THE RIGHT TO LOWER.



### SAFETY ALERT OPERATING TILT UP/DOWN



**! WARNING**

**CRUSH HAZARD**

Can cause serious injury.

Stay clear of moving mechanism of Pan Mixer .

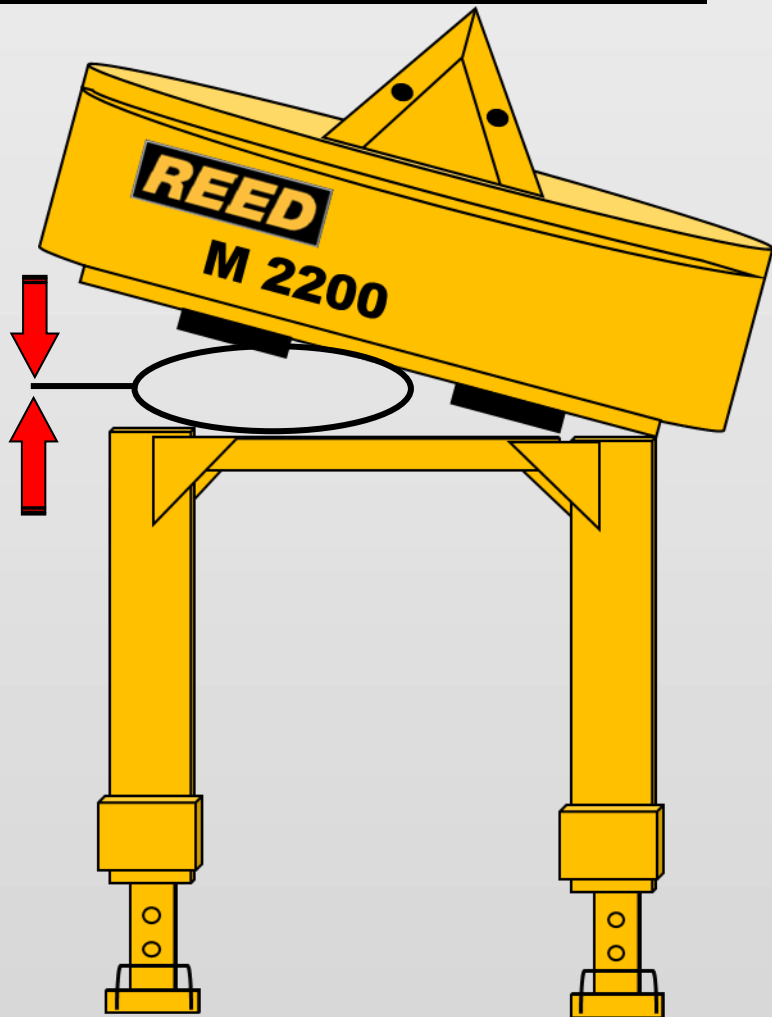

HOW TO OPERATE **CLEAN-OUT DOOR**, THIS DOOR IS A MANUAL TYPE.  
UNLOCK THE LUCKS AND OPEN THE DOOR MANUAL, THEN LIFT MIXER UP FOR  
CLEAN OUT.

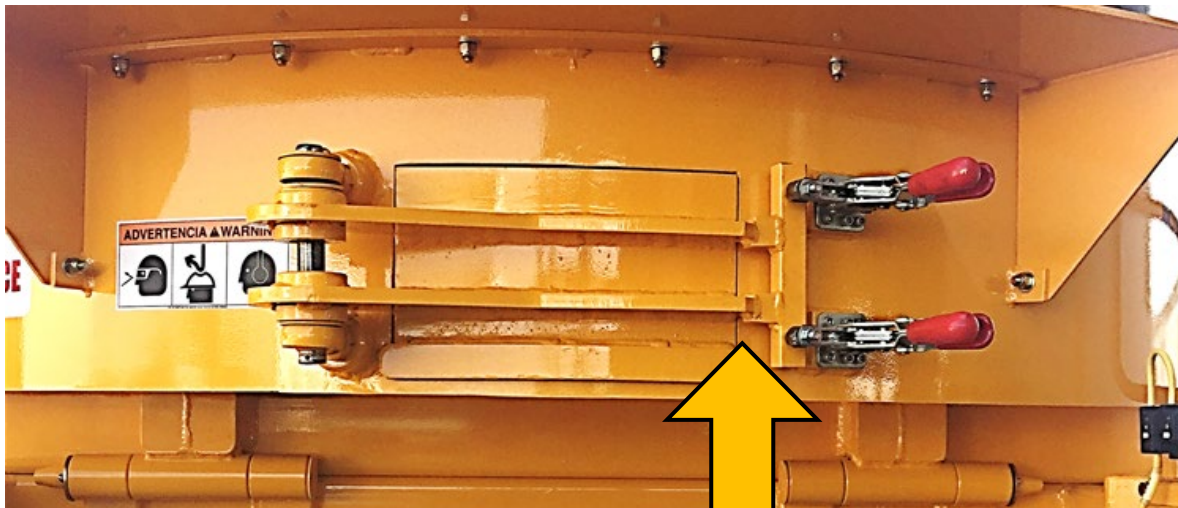

**OPEN MANUAL  
DOOR HERE**

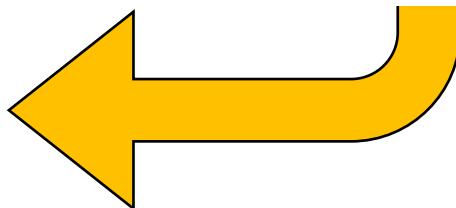

## OPERATION OF PAN MIXER

### CHEMICAL/WATER TANK (OPTION)

- THE STAINLESS-STEEL TANK IS A FOLD DOWN/UP TYPE WITH VALVES TO FILL THE TANK WITH WATER OR CHEMICAL DEPENDING ON THE APPLICATION AND MIX DESIGN.
- THERE IS A DISPERSION TUBE THAT HAS A QUICK DISCONNECT THAT WILL ALLOW IT TO BE STOWED DURING MOVING AND RELOCATION, THIS TUBE IS FITTED WITH OUTLET ORFICES FOR WATER OR CHEMICAL ADDITIVE TO FLOW INTO THE MIX BELOW.



## MAINTENANCE

### RECOMMENDED MAINTENANCE PRACTICES

#### MAINTENANCE MANAGEMENT

Schedule lubrication and maintenance inspections to anticipate maintenance issues. Maintenance management requires the assignment of responsibilities to individual personnel, training of personnel, keeping of records, and the exercise of judgment.

#### INSPECTION AND LUBRICATION CHECKLISTS AND OPERATOR REPORTS

Utilize checklists for scheduled inspection and lubrication and maintain a written record regarding observations and actions performed. Maintain all scheduled maintenance reports by the operator listing any malfunctions and observations.

#### MIXER HISTORY FILE NOTING MIXER SERIAL NUMBER

File the operator reports, inspection and lubrication checklists, shop repair, work orders and tickets, parts replacement and pump usage records. This file should also include the parts book for the specific serial number and engine.

#### ANNUAL REVIEW

Review the history records of each unit once every year to find evidence of repetitive failures, adjustments, problems, or excessive wear so that action can be taken to minimize breakdowns and reduce excessive maintenance costs. A review of the machine history will help in the stocking of spare parts and assemblies in advance of a possible need.

### **CAUTION**

Engine Manufacturer Maintenance Schedule Must Be Followed  
Read Engine Manufacturer Manual

**REED** has provided only general guidelines regarding engine maintenance and will not cover engine warranty claims.

### MAINTENANCE



Hydraulic Pressure in All Systems Must Be ZERO Before and During Any Maintenance Procedures

Engine Must Be Turned OFF and Lockout / Tagout Procedures Must Be Followed Before and During Any Maintenance Procedures





## GENERAL MAINTENANCE AREAS

Perform scheduled inspections to identify and detect any potential problems. The list presented should be inspected and checked on a regular basis and is a recommended minimum.

### MAIN CONTROLS

- Control box in good condition, sealed, not damaged
- All Switches, Push buttons, E-Stop in good condition, not broken, jammed or bent and stay in position or momentarily return to center
- Control identification in good condition, legible
- Gauges in good condition

### REMOTE CONTROLS

- Control console in good condition, not damaged
- Switch in good condition
- Cord in good condition, no cuts, securely mounted to box

### HYDRAULIC SYSTEM

- Hydraulic tank securely mounted, covers tight
- Breather, filler cap and strainer in place, level sight gauge in proper condition
- Check filter condition indicators
- Hydraulic oil cooler securely mounted; connections tight
- Hydraulic fluid to proper level and clean
- All hoses and tubing secure, check for leaks

## LUBRICATION

Rapid wear and possible shutdown will result if the unit is operated with inadequate lubrication. Follow the recommendations stated herein, and if needed increase the application of lubricants above these recommendations when the equipment is subject to heavy usage.

### RECOMMENDED LUBRICATING INTERVALS

Recommended lubrication intervals are based on normal use under normal conditions. The lubrication interval must be increased to meet more challenging uses and uses which subject the equipment to high and/or unusual concentration of forces. The lubrication interval must be increased if the pump has been exposed to environmental conditions such as low humidity, high humidity, excessive dust, high temperatures, low temperatures, heavy rainfall, long term storage, ocean air, etc...

- 1) every hour of operation
- 2) after completion of every job

All lubrication points must be greased on every interval as recommended.

### TYPE OF LUBRICANT

- Use EP grease, extreme pressure grease available for wheel bearings, general purpose grease, Shell Alvania EP (LFH2), or equivalent if this lubricant is unavailable in your area



- Do NOT use Moly grease, grease with Moly additives

### LUBRICATION POINTS

The following graphics are for REFERENCE ONLY.

### LUBRICATION POINTS

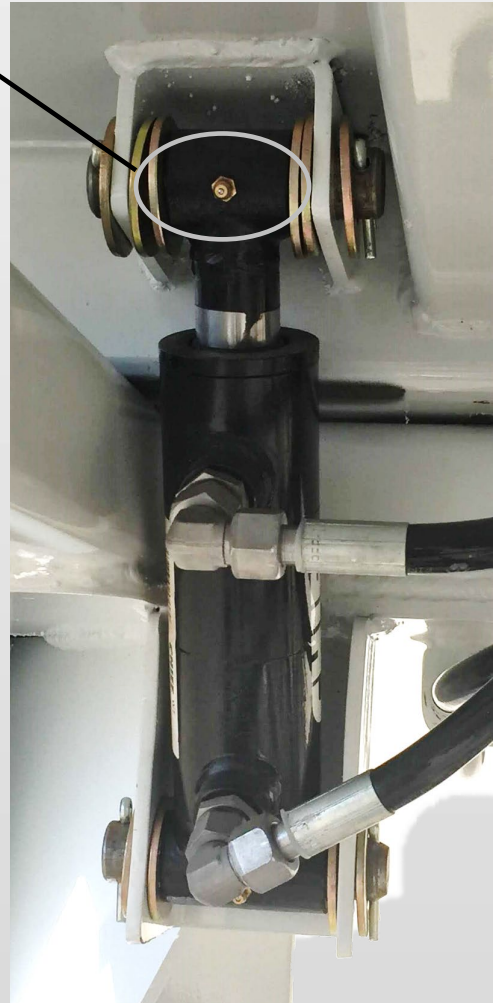

### HYDRAULIC SYSTEM

Hydraulic pumps are used to supply the flow of oil necessary to operate actuators of the Pan Mixer.

**CAUTION**

Contamination of the Oil Is the Leading Contributor to System Malfunctions

Extreme care must be exercised to prevent contaminants from entering the system. Always cap or plug open ports and hydraulic lines.

### HYDRAULIC TANK

Hydraulic tank can be equipped with an access cover with breather. A sight and temperature gauge are installed on the tank to determine the fluid level and temperature inside the tank. The tank is also equipped with drain valve.

To accomplish filtration, hydraulic tanks can be equipped with the following: internal magnetic suction strainers, a suction filter, a return filter and a pressure filter.

NOTE: Not all models use all these components. Suction and return filters are equipped with an indicator gauge to monitor filter restriction. An oil cooler is adjacent to the engine cooling unit.

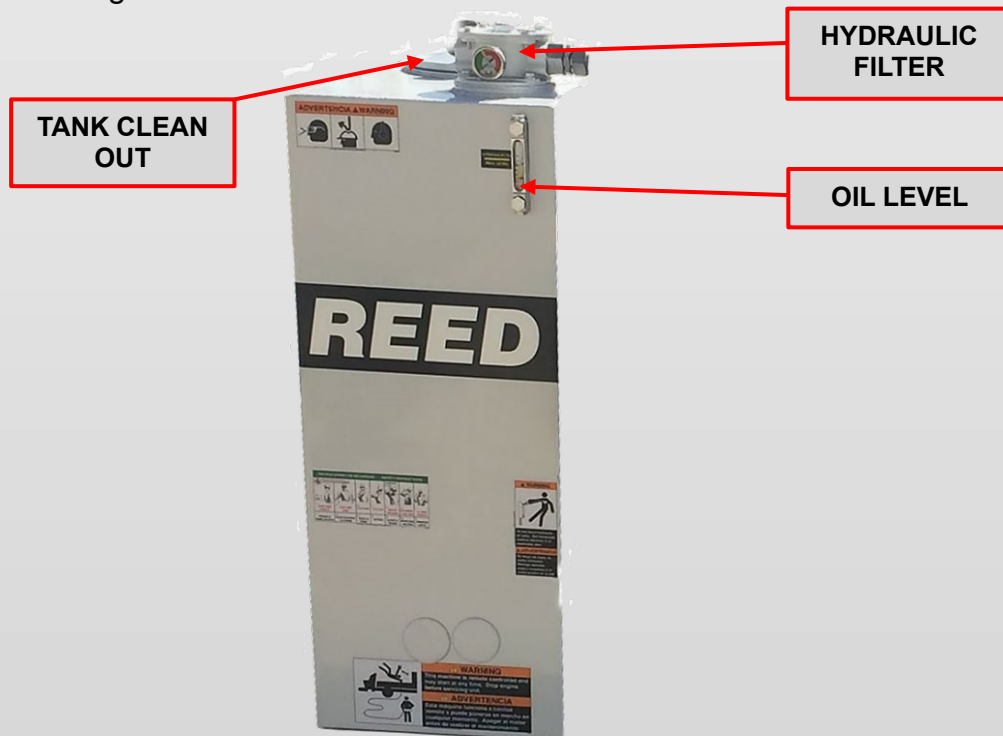

## HYDRAULIC SYSTEM MAINTENANCE ITEM DESCRIPTIONS

### FLUID

Check fluid level and oil clarity daily with sight gauge provided. Maintain level at full mark. Add hydraulic oil through the return filter fill port when necessary.

### TANK BREATHER

Clean every 50 hours of operation. Remove from tank, clean with solvent and air blow dry.

### FILTER

Change after first 50 hours of operation. Thereafter change every 250 hours of operation or when condition gauge indicates change is necessary.

### HYDRAULIC TANK

Change oil in tank every 500 hours of operation or yearly, whichever comes first.

### HYDRAULIC FLUID

The hydraulic system is filled with Shell Oil Company TELLUS #46. It is to be used in ambient temperatures of 39-90° F (4-32° C). The normal fluid temperature will range from 100-167° F (38-75° C).

For ambient temperatures of 90° F (32° C) and above, use fluid designated with an ISO rating of 68. Use ISO 32 for ambient temperatures of 32° F (4° C) and below.

**CAUTION**

Use Only Shell Tellus 46 or Equivalent  
Never Mix with Other Types of Fluids

**CAUTION**

Always Use Clean and New Fluid

Using impure or other type of fluids not specified will contaminate the hydraulic system and lead to eventual system malfunction and/or damage.

### ADDING HYDRAULIC FLUID

There are a few common methods for filling the hydraulic tank as described below. Exercise extreme care when adding fluid to the hydraulic tank to avoid contamination.

- To prevent any dirt or water from entering the hydraulic tank, thoroughly clean area around the return filter fill port plug, the vented fill cap or the inspection cover.
- Remove return filter fill port plug, vented cap or inspection cover.
- Fill system to MAX LEVEL mark on sight gauge with new clean hydraulic fluid. If a pump is used to transfer the fluid, ensure the pump filter is clean. If pouring fluid from a container, pour it through a fine wire mesh screen, 200 mesh or finer.
- Replace filter fill port plug, vented cap or inspection cover immediately after filling tank to proper level.

**CAUTION**

Do Not Use Cloth for Straining Fluid  
Lint Is a Contaminant Harmful to the Hydraulic System

### FILTER SERVICING

Hydraulic filters provide a means of continuous hydraulic fluid filtration to prevent recirculation of contamination which will cause rapid wear and component breakdown.

A filter that is equipped with a condition indicator gauge should be checked daily and the element changed when indicated to do so. Below are TYPICAL filters and filter elements.

RETURN FILTER

FILTER ELEMENT

FILTER INDICATOR      FILL PORT





## To change the filter elements:



1. Shut off machine.
2. VERIFY PRESSURES IN ALL CIRCUITS READ ZERO!
3. Wipe clean any dirt and grime from area surrounding filter housing
4. Loosen the filter cover plate bolts
5. Carefully remove cover so as not to damage the gasket or O-ring
6. Discard only element and discard responsibly
7. Install bypass valve (if equipped) and new element and replace cover
8. Wipe clean any contaminants around high pressure filter
9. Remove filter housing then remove and discard filter element
10. Check and replace O-ring or gasket if necessary
11. Replace filter element and install filter housing
12. Start-up machine and observe for leakage

## CAUTION

Do Not Wash Out and Reuse Disposable Filter Elements

### CLEANING THE HYDRAULIC TANK

The hydraulic tank should be drained and cleaned after 500 hours of operation or yearly, whichever occurs first, to assist in keeping the systems clean and in proper condition.

1. Shut off machine
2. VERIFY PRESSURES IN ALL CIRCUITS READ ZERO!
3. Place a suitable size container under the hydraulic tank drain fitting and then remove drain plug. Dispose of used oil responsibly
4. After draining, remove the access cover on the hydraulic tank being careful not to damage the gasket
5. Remove, disassemble and clean magnetic suction strainers before reassembly (if equipped)
6. Flush the inside of hydraulic tank with clean solvent and wipe clean with lint free cloths
7. Install suction strainers (if equipped)
8. Replace sight gauge
9. Install the tank drain plug and access cover with gasket.
10. Change the hydraulic system filter element(s) and breather cap
11. Refill the hydraulic tank with new clean hydraulic fluid to MAX LEVEL mark
12. Start machine and check for leaks

## COMPONENT REPLACEMENT

When parts are worn, do not delay in replacement. Continued usage with worn parts may lead to damage of other components.

Please contact the **REED** Service Department or your local dealer for technical support.



# PUMP MAINTENANCE SCHEDULE AND CHECKLISTS

Providing a maintenance schedule defined specifically by run hours or yardage pumped serves only as a general guideline given the large amount of variables a unit might be subject to, such as weather and ambient temperature conditions, jobsite conditions, material differences of mix design, the load burden the unit is typically subject to, i.e. light, medium or heavy duty operation, etc.

The list that follows is to be used as a reference guide. However, the end user is encouraged to develop a preventative maintenance program that specifically suites their needs depending on the usage of the equipment.

DAILY PUMP MAINTENANCE CHECKLIST		
Actual Hours _____		Date ___ / ___ / ___
#	Maintenance Description	Initials
1	Check hydraulic tank fluid levels	
2	Check condition of hydraulic oil for water or other contamination.	
3	Drain water from hydraulic tank	
4	Check engine fluid levels (see engine manufacturer maintenance schedule for additional requirements)	
	Additional Notes:	
5	Check hydraulic filter indicator condition	
6	Lubricate lubrication points, during and after pumping	
7	Inspect unit for fluid leaks, loose hoses, loose nuts, bolts, fasteners etc.	
	Additional Notes:	
8	Additional Notes:	



# OPERATION and MAINTENANCE



(909)287-2100

INITIAL 50 HOUR MAINTENANCE CHECKLIST		
Actual Hours _____		Date ____ / ____ / ____
#	Maintenance Description	Initials
1	Change engine oil and filters (see engine manufacturer maintenance schedule for additional requirements) IF REQUIRED	
	Additional Notes:	
2	Change hydraulic oil filters	
3	Inspect hydraulic hoses and fittings for any signs of external wear or damage	
	Additional Notes:	



# OPERATION and MAINTENANCE



(909)287-2100

EVERY 100 HOUR MAINTENANCE CHECKLIST		
Actual Hours _____		Date ____ / ____ / ____
#	Maintenance Description	Initials
1	Clean hydraulic tank breather	
2	Inspect all structural components (check frame, hopper, and other structural members for any damage)	
	Additional Notes:	
	Additional Notes:	
3	Check coolers and radiators for dirt or debris. Clean as necessary	
4	Check condition of engine drive belts. Change if necessary (see engine manufacturer maintenance schedule for additional requirements) IF REQUIRED	
Additional Notes:		



# OPERATION and MAINTENANCE



(909)287-2100

EVERY 250 HOUR MAINTENANCE CHECKLIST		
Actual Hours _____		Date ____ / ____ / ____
#	Maintenance Description	Initials
1	Change hydraulic filters (or change more frequently as indicated by indicator gauge on filter)	
	Additional Notes:	
2	Check that all electrical wires, cables, terminals, plugs are in good condition	
	Additional Notes:	
3	Change engine oil and filters (see engine manufacturer guide for all engine requirements) IF REQUIRED	
	Additional Notes:	
4	Check condition of fuel hoses, fittings, and clamps	
	Additional Notes:	
5	Inspect all safety decals to ensure that they are completely visible and legible	
6	Perform complete inspection of the controls	
7	All toggles in good condition, stay in position or momentarily return to center	
8	Control identification in good condition, legible	
9	Perform complete inspection of the controls	
10	All toggles in good condition, stay in position or momentarily return to center	
11	Control identification in good condition, legible	
12	Gauges in good condition	
	Additional Notes:	





# OPERATION and MAINTENANCE



(909)287-2100

EVERY 250 HOUR MAINTENANCE CHECKLIST		
Actual Hours _____		Date __/__/__
#	Maintenance Description	Initials
13	Control console in good condition	
14	Switch in good condition	
	Additional Notes:	



# OPERATION and MAINTENANCE



(909)287-2100

EVERY 500 HOUR MAINTENANCE CHECKLIST		
Actual Hours _____		Date ____ / ____ / ____
#	Maintenance Description	Initials
1	Inspect hydraulic hoses and fittings for any signs of external wear or damage	
	Additional Notes:	
2	Inspect all wear parts and change as necessary (excessive wear may cause inefficient performance and/or shutdown of operation)	
	Additional Notes:	
3	Change hydraulic fluid, clean the reservoir and the suction strainers within reservoir, and replace all hydraulic oil filters	
	Additional Notes:	
4	Complete inspection of the engine (refer to engine manufacturer maintenance schedule for details) IF REQUIRED	
5	Inspect mountings, bolts, brackets	
6	Oil level proper, coolant level proper, check for leaks	
7	Fuel system, tank mounting, filter condition, check for leaks, damaged lines	
11	Air cleaner and muffler securely mounted IF REQUIRED	
Additional Notes:		





**OPERATION and MAINTENANCE**



**(909)287-2100**

---

**NOTES**

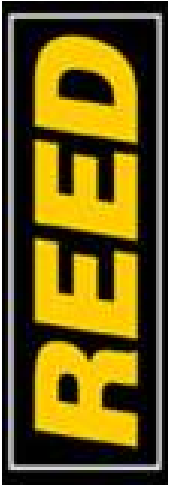

# 88733 PAN-MIXER CONTROL PANEL W/SPEED CONTROL

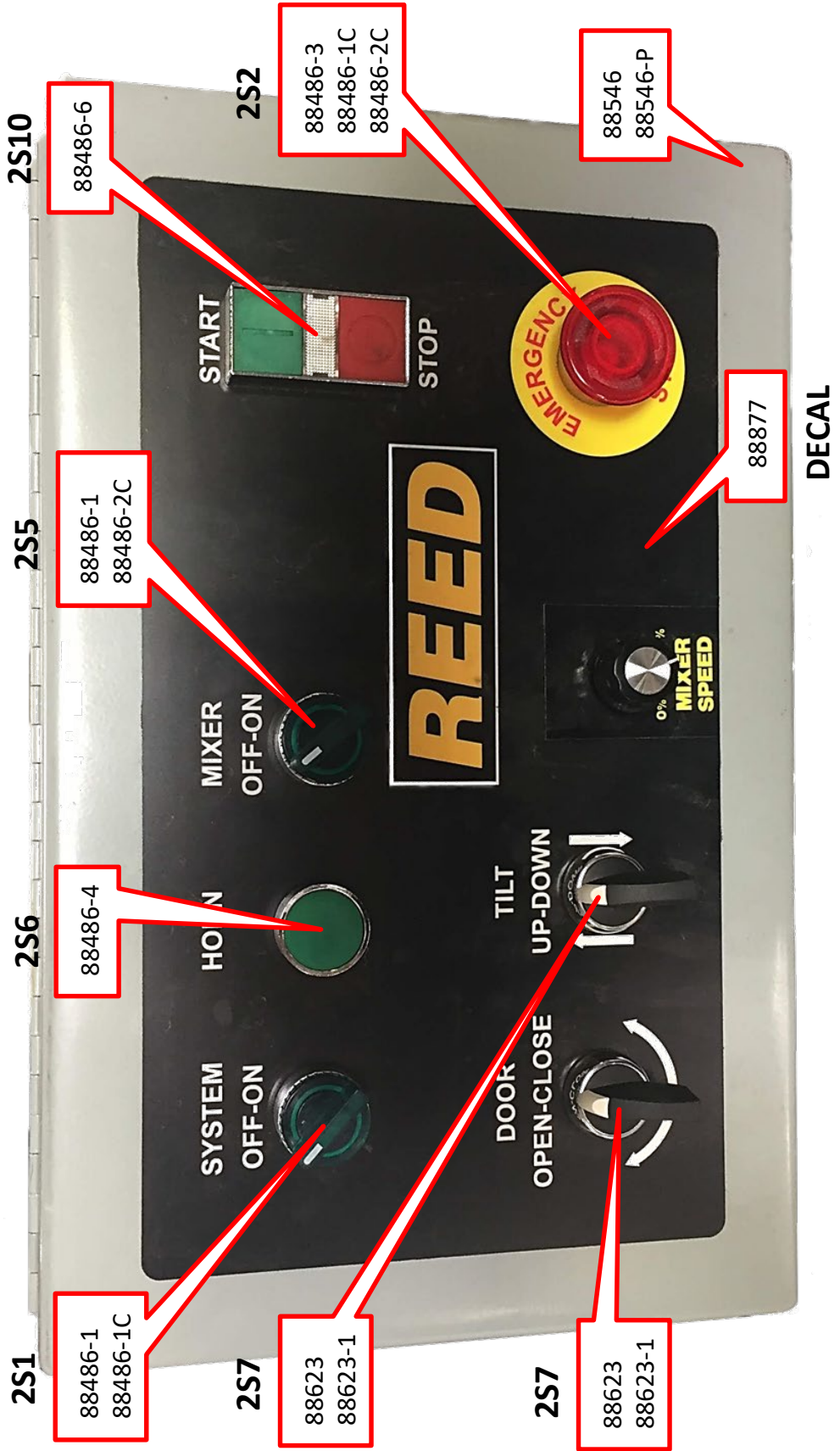

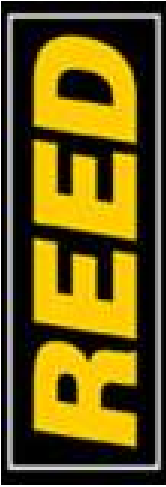

# 88733 PAN-MIXER DOOR CONTACT LAYOUT

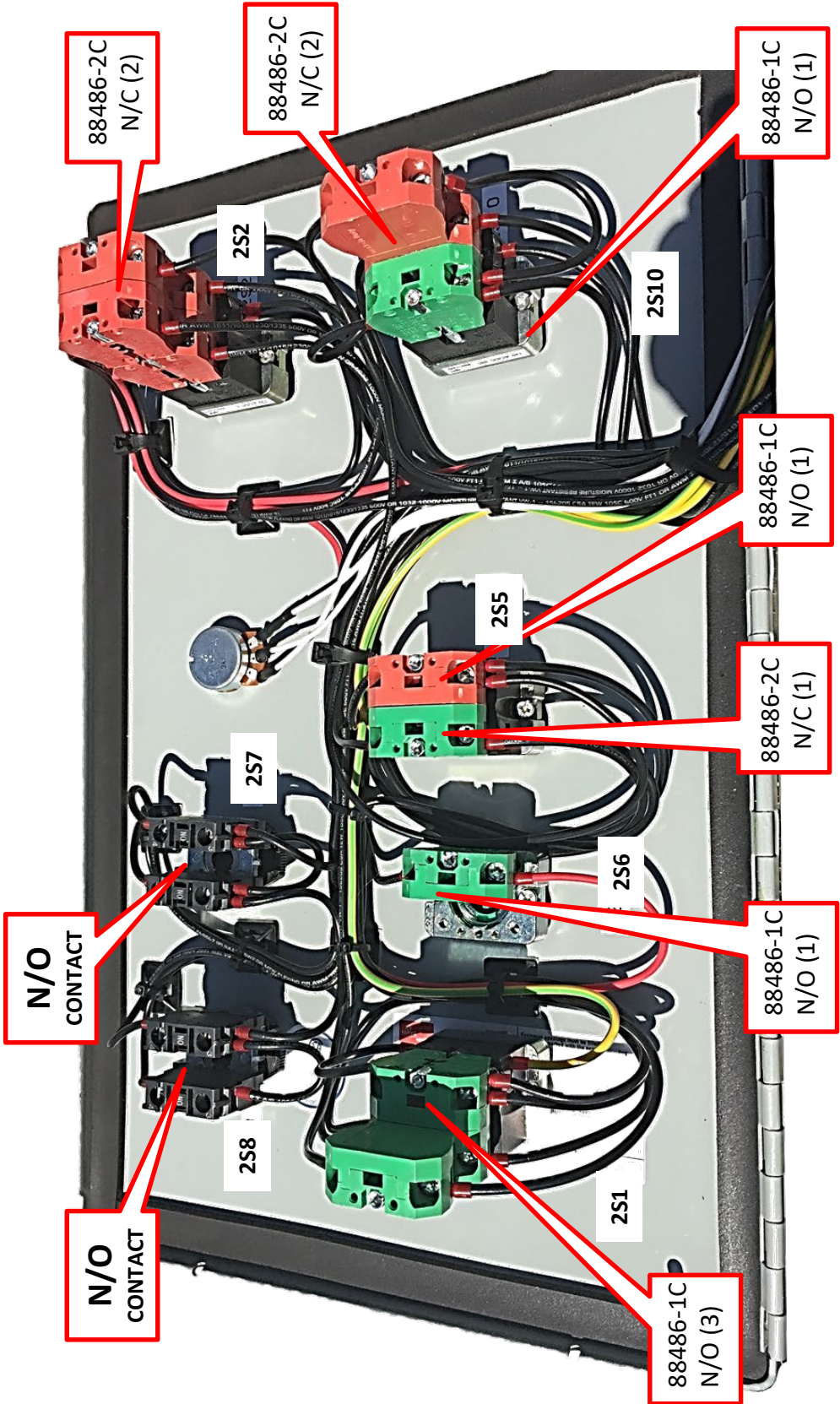



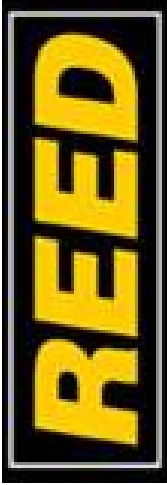

# 88733 PAN-MIXER FUSE/DIODE/GROUND BLOCK

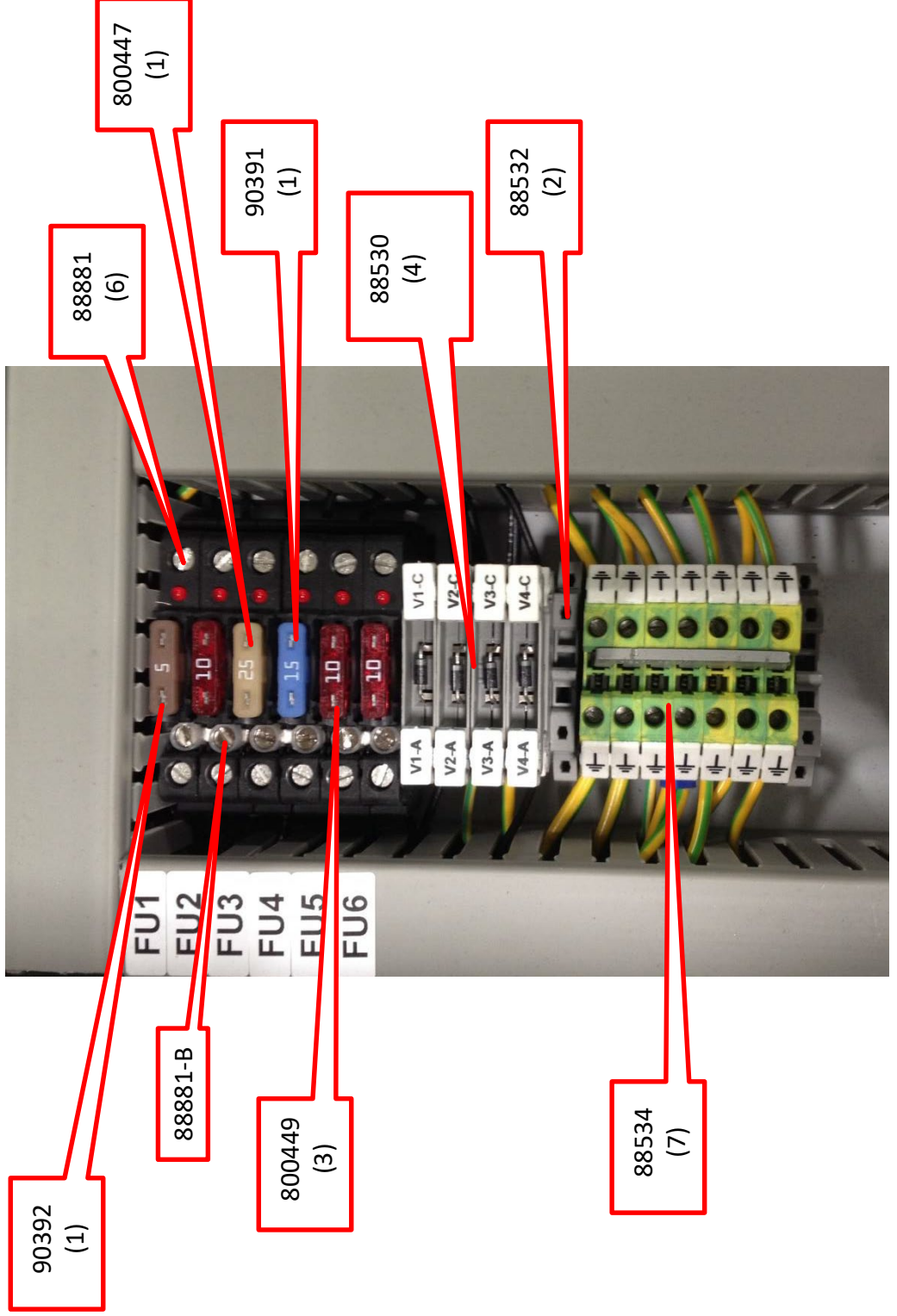

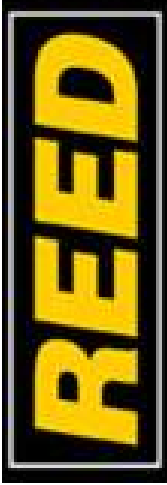

# 88733 PAN-MIXER RELAY / TIMER

**2T1**  
TIMER

W-105331-1  
(1)

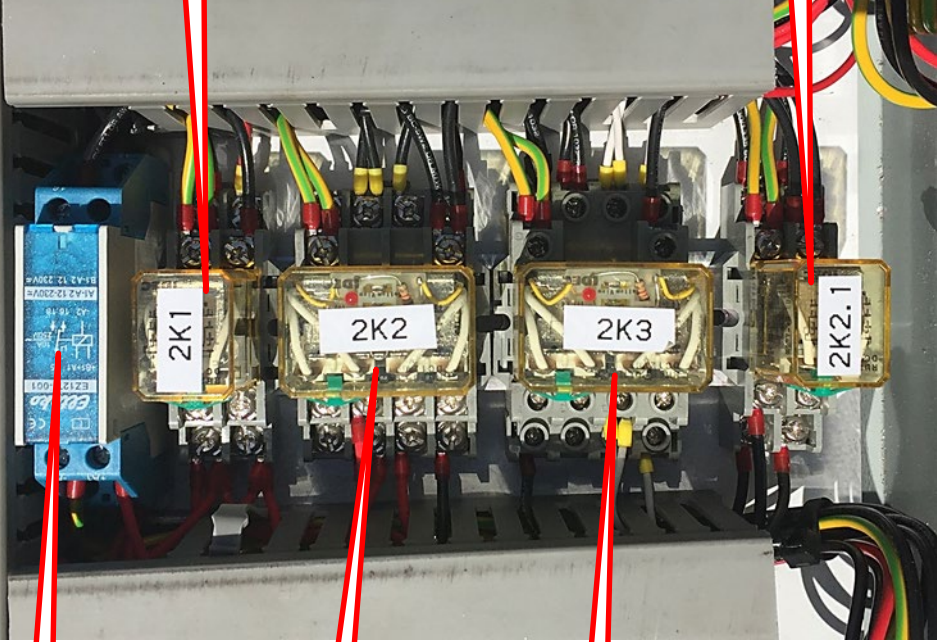

**2K1**  
RELAY/  
SOCKET BASE

88345-1  
88347

**2K2**  
RELAY/  
SOCKET BASE

88527  
88527-1

**2K3**  
RELAY/  
SOCKET BASE

88527  
88527-1

**2K2.1**  
RELAY/  
SOCKET BASE

88345-1  
88347

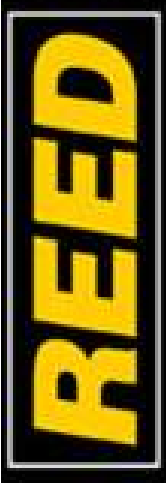

# 88733 PAN-MIXER RELAY / TIMER

**2T2**  
TIMER

W-106393  
FINDER

**2K4**  
RELAY/  
SOCKET BASE

88345-1  
88347

89734  
89741  
89742  
89743

**Single output  
Proportional  
controller**

**2K5**  
RELAY/  
SOCKET BASE

88345-1  
88347

88881  
90392

**2K1**  
RELAY/  
SOCKET BASE

W-105618  
W-105517  
W-105619

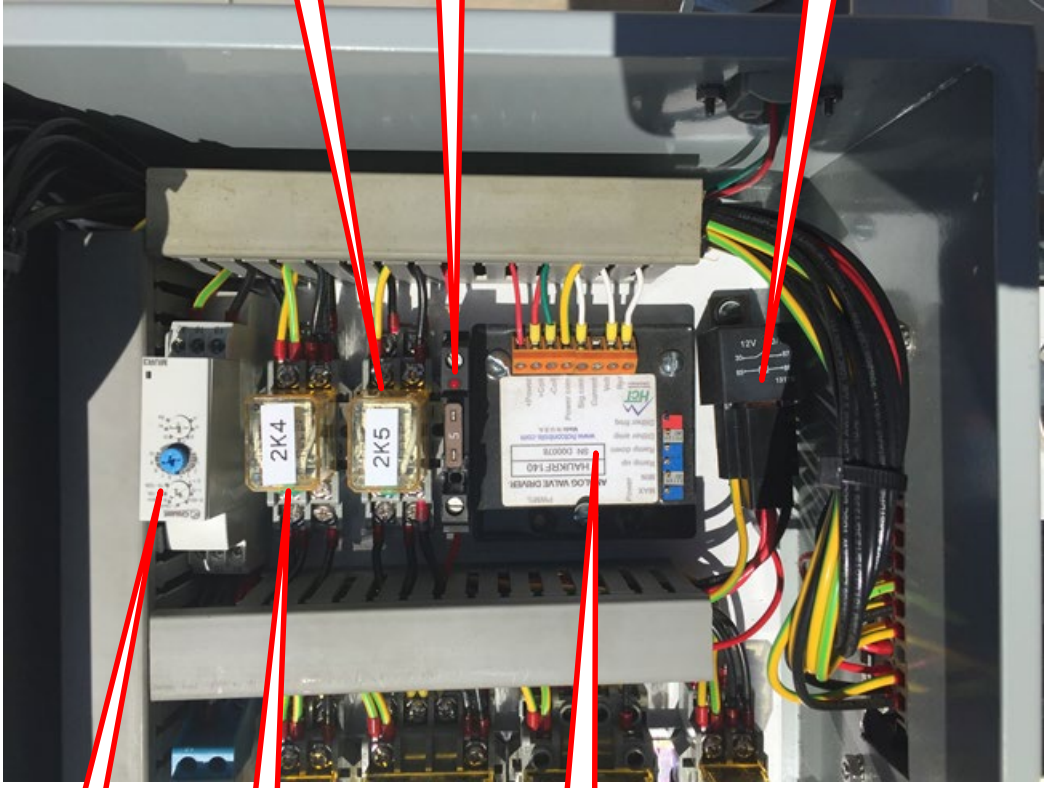

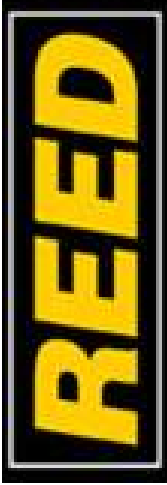

# 88733 PAN-MIXER PLUG/CONNECTOR





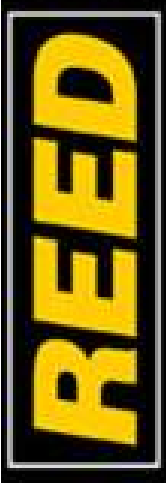

# 88733 PAN-MIXER DUCTING/DIN RAIL LAY-OUT

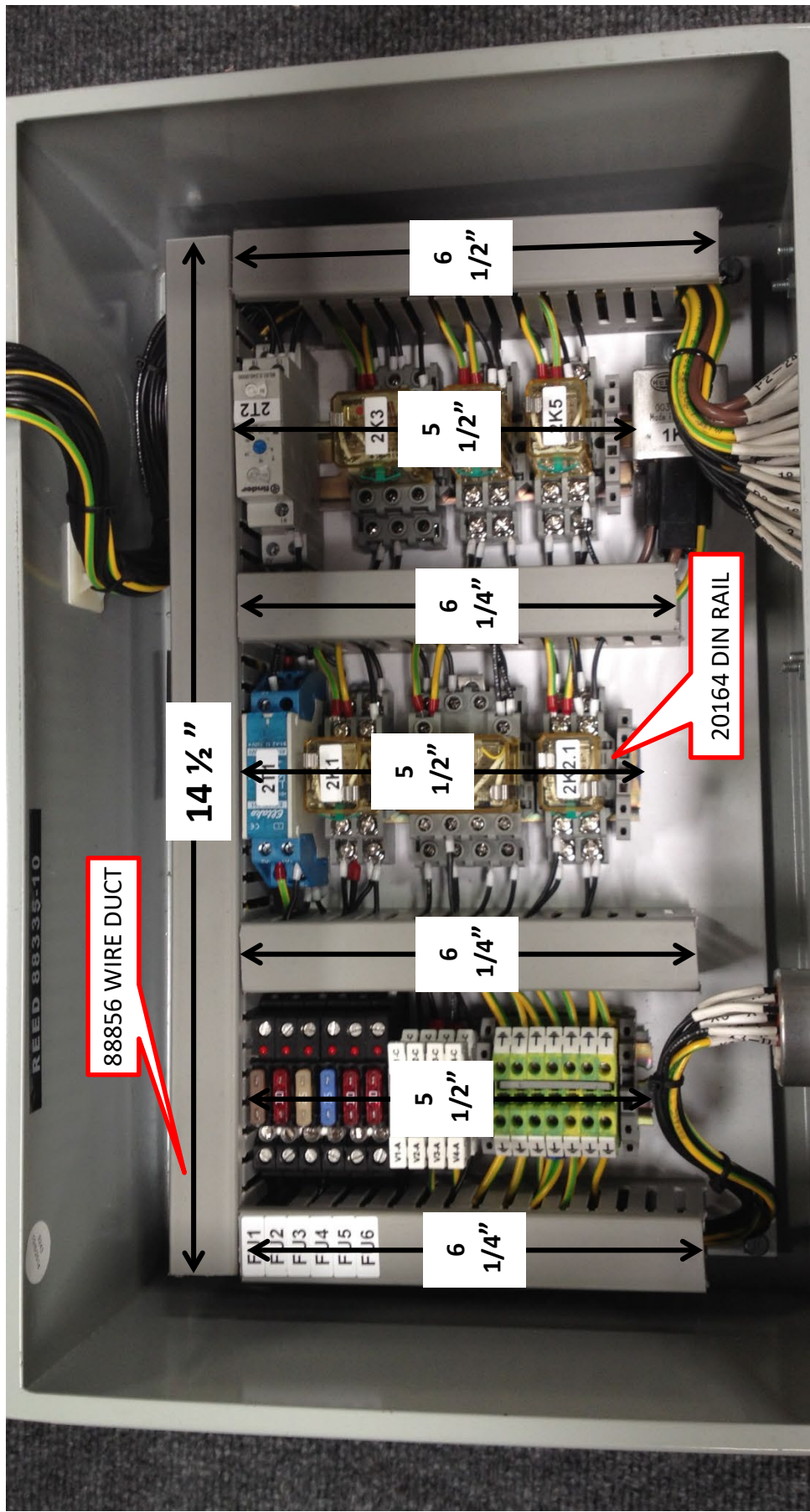

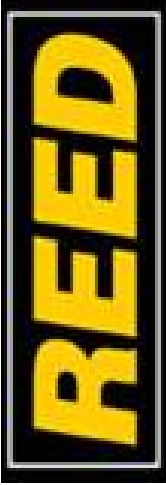

# 88335-10 PAN-MIXER HARNES LAY-OUT

## 89733-H

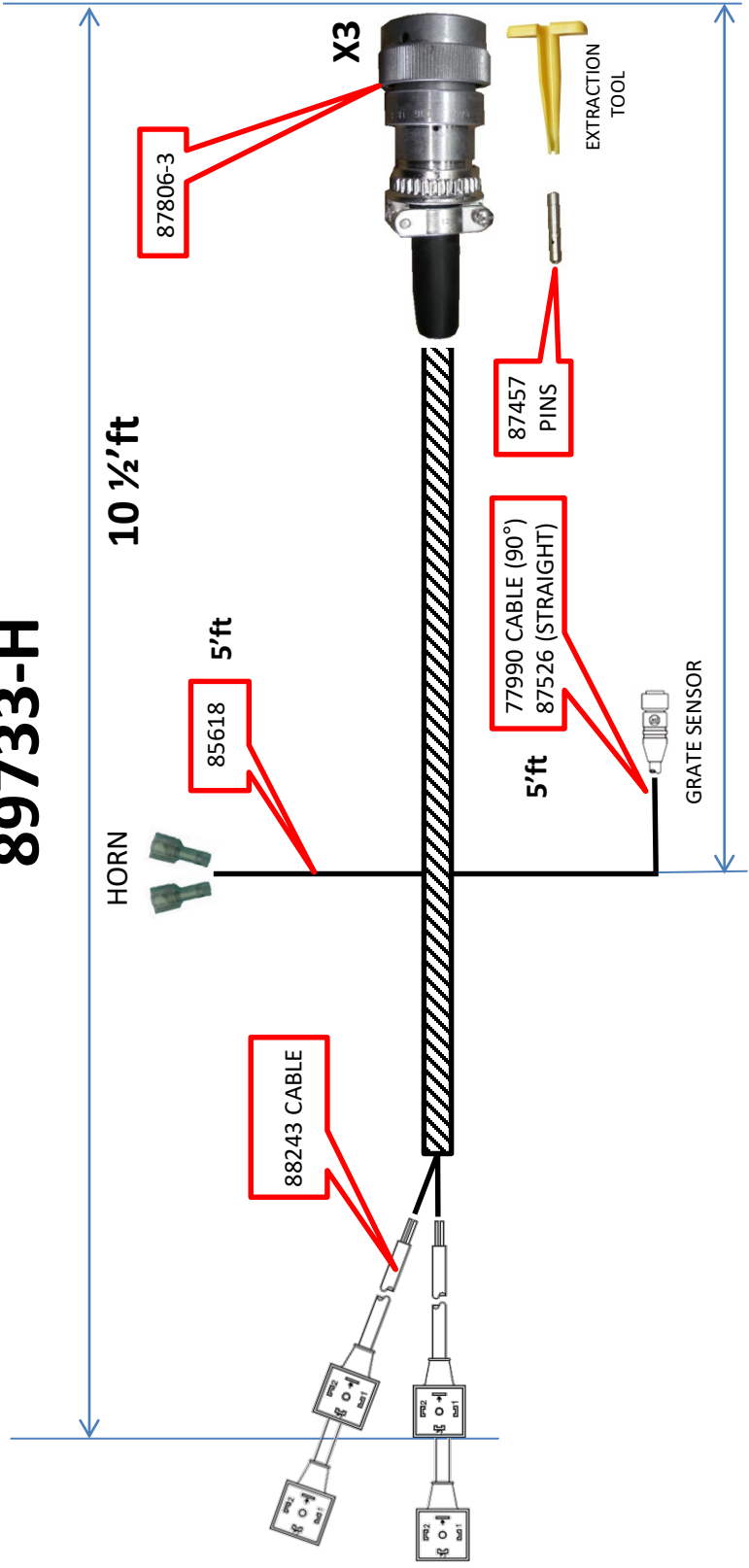



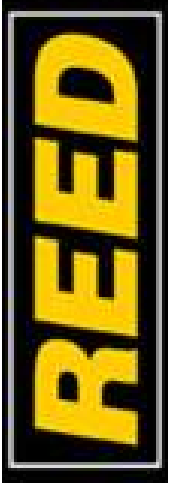

# 88335-10 PAN-MIXER HARNES SCHEMATIC

## 89733-H

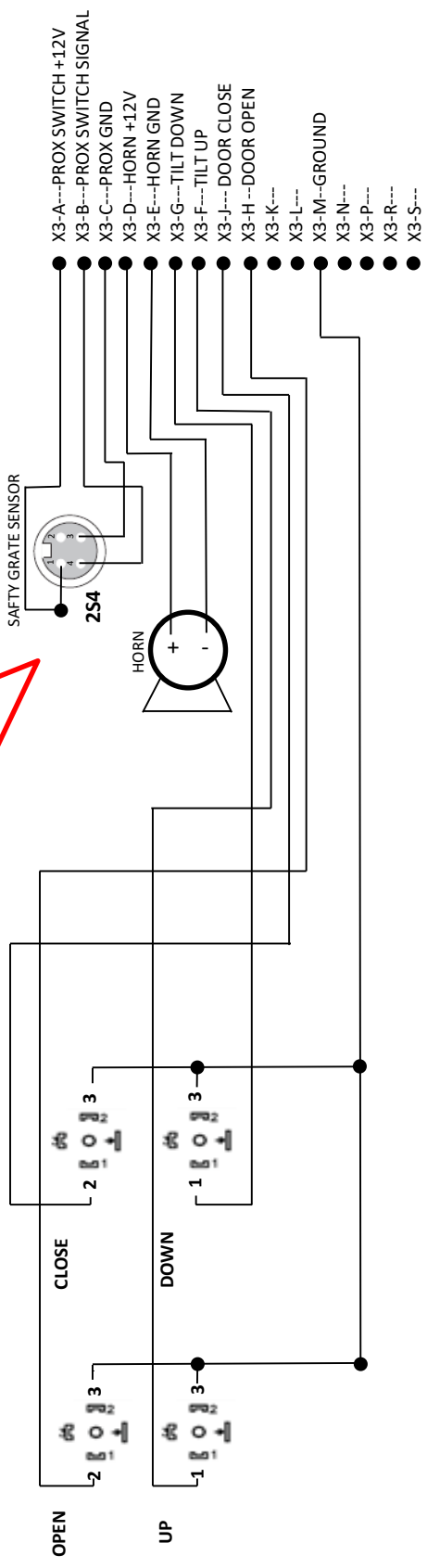

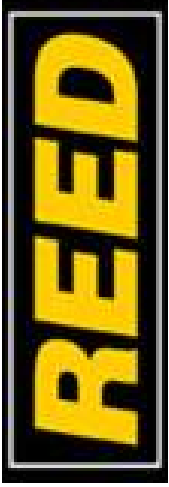

# 88335-10 PAN-MIXER HARNESS LAY-OUT

## 88610 POWER PACK TO PAN MIXER EXTENTION CABLE

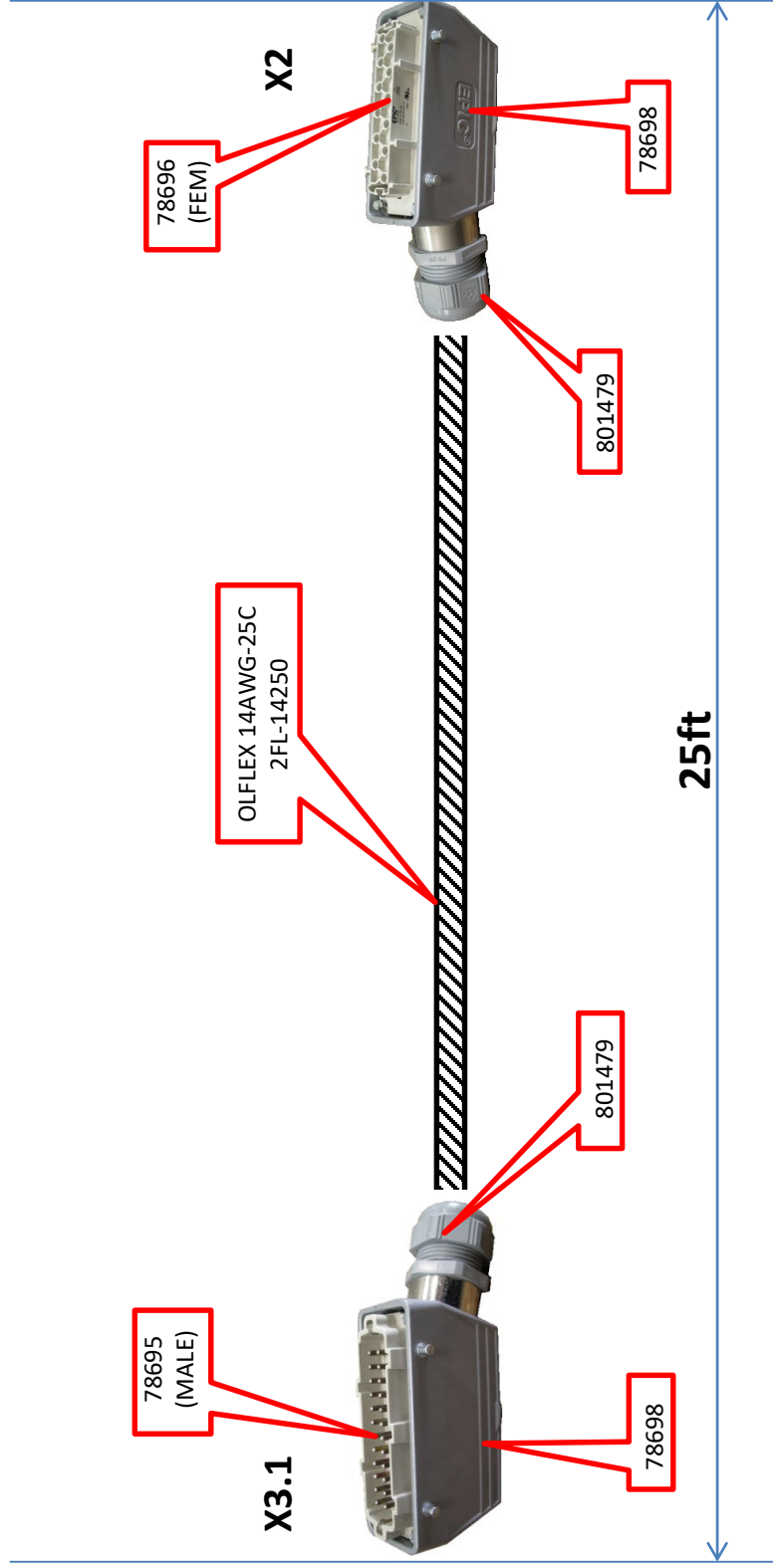

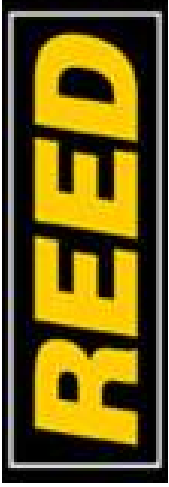

# 88335-10 PAN-MIXER HARNES SCHEMATIC

88610

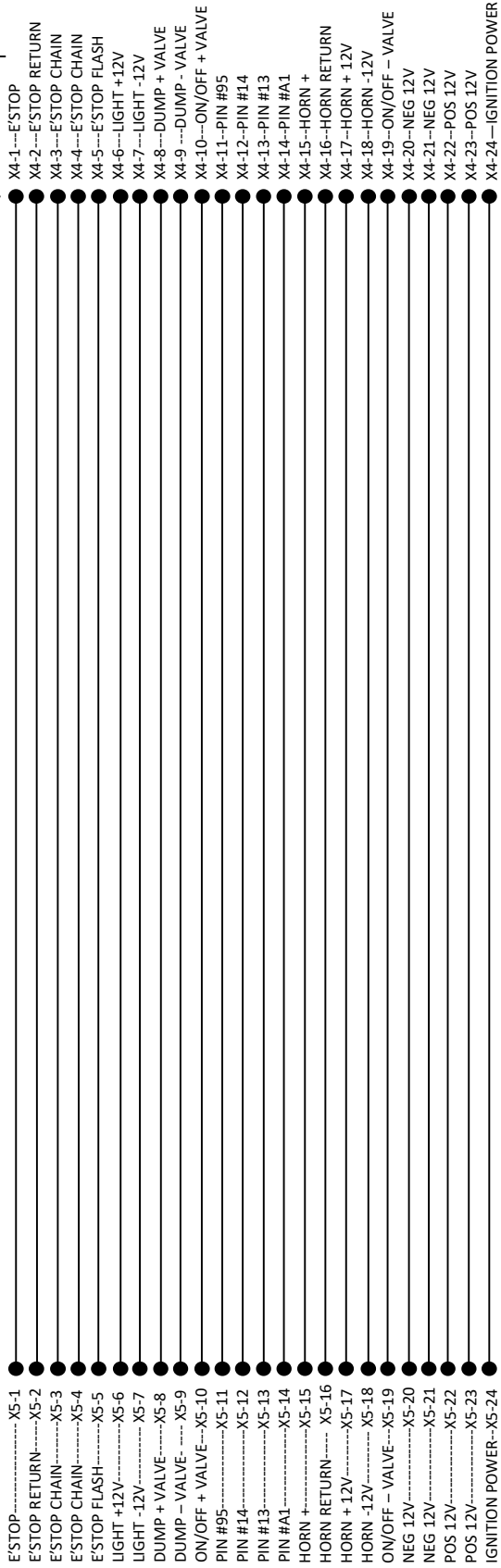
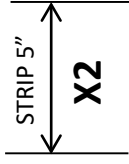
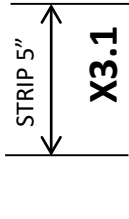



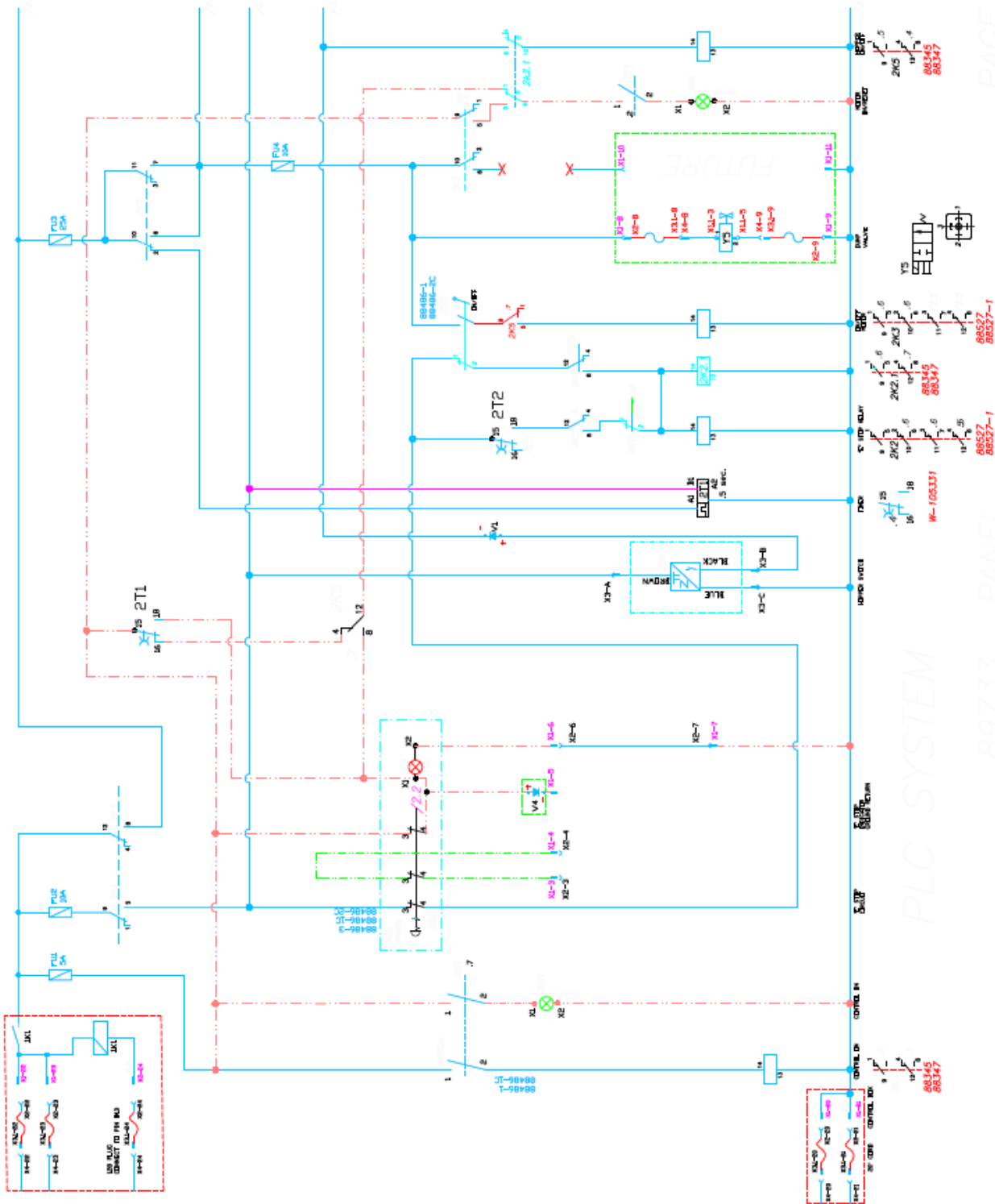

PLC SYSTEM  
89733 PANEL

89349  
89347

89349  
89347

89349  
89347

89349  
89347

89349  
89347

89349  
89347

89349  
89347

89349  
89347

89349  
89347

89349  
89347

89349  
89347

89349  
89347

89349  
89347

89349  
89347

89349  
89347

89349  
89347

89349  
89347

89349  
89347

89349  
89347

89349  
89347

89349  
89347

89349  
89347

89349  
89347

89349  
89347

89349  
89347

89349  
89347

89349  
89347

89349  
89347

89349  
89347

89349  
89347

89349  
89347

89349  
89347

89349  
89347

89349  
89347

89349  
89347

89349  
89347

89349  
89347

89349  
89347

89349  
89347

89349  
89347

89349  
89347

89349  
89347

89349  
89347

89349  
89347

89349  
89347

89349  
89347

89349  
89347

89349  
89347

89349  
89347

89349  
89347

89349  
89347

89349  
89347

89349  
89347

89349  
89347

89349  
89347

89349  
89347

89349  
89347

89349  
89347

89349  
89347

89349  
89347

89349  
89347

89349  
89347

89349  
89347

89349  
89347

89349  
89347

89349  
89347

89349  
89347

89349  
89347

89349  
89347

89349  
89347

89349  
89347

89349  
89347

89349  
89347

89349  
89347

89349  
89347

89349  
89347

89349  
89347

89349  
89347

89349  
89347

89349  
89347

89349  
89347

89349  
89347

89349  
89347

89349  
89347

89349  
89347

89349  
89347

89349  
89347

89349  
89347

89349  
89347

89349  
89347

89349  
89347

89349  
89347

89349  
89347

89349  
89347

89349  
89347

89349  
89347

89349  
89347

89349  
89347

89349  
89347

89349  
89347

89349  
89347

89349  
89347

89349  
89347

89349  
89347

89349  
89347

89349  
89347

89349  
89347

89349  
89347

89349  
89347

89349  
89347

89349  
89347

89349  
89347

89349  
89347

89349  
89347

89349  
89347

89349  
89347

89349  
89347

89349  
89347

89349  
89347

89349  
89347

89349  
89347

89349  
89347

89349  
89347

89349  
89347

89349  
89347

89349  
89347

89349  
89347

89349  
89347

89349  
89347

89349  
89347

89349  
89347

89349  
89347

89349  
89347

89349  
89347

89349  
89347

89349  
89347

89349  
89347

89349  
89347

89349  
89347

89349  
89347

89349  
89347

# REED

## WIRING HARNESS PAN MIXER

B-SERIES

SCMTC

PAGE 1 of 1

DRAWING NO. REV DATE  
89733-H

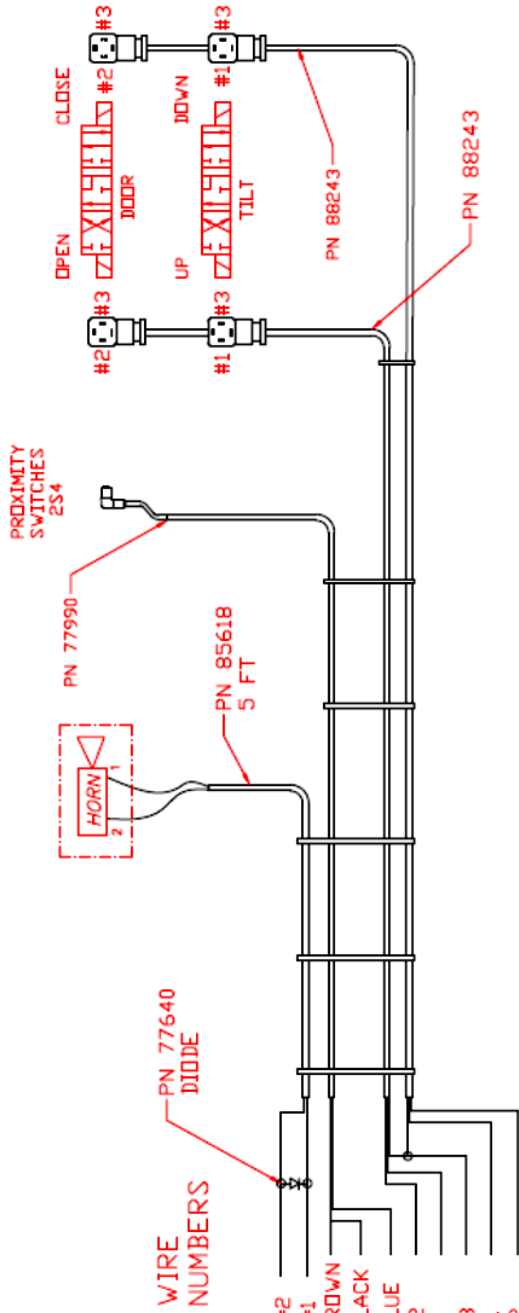

PN 87806-3 PLUG  
PN 87457 PINS

16 PIN  
PLUG  
X3

- |                    |    |       |
|--------------------|----|-------|
| HORN -             | #E | #2    |
| HORN +             | #D | #1    |
| PROX SWITCH +12V   | #A | BROWN |
| PROX SWITCH SIGNAL | #B | BLACK |
| PROX SWITCH -12V   | #C | BLUE  |
| DUMP DOOR OPEN     | #H | #2    |
| TILT UP            | #F | #1    |
| TILT DOWN          | #M | #3    |
| DUMP DOOR CLOSE    | #J | #2    |



89792

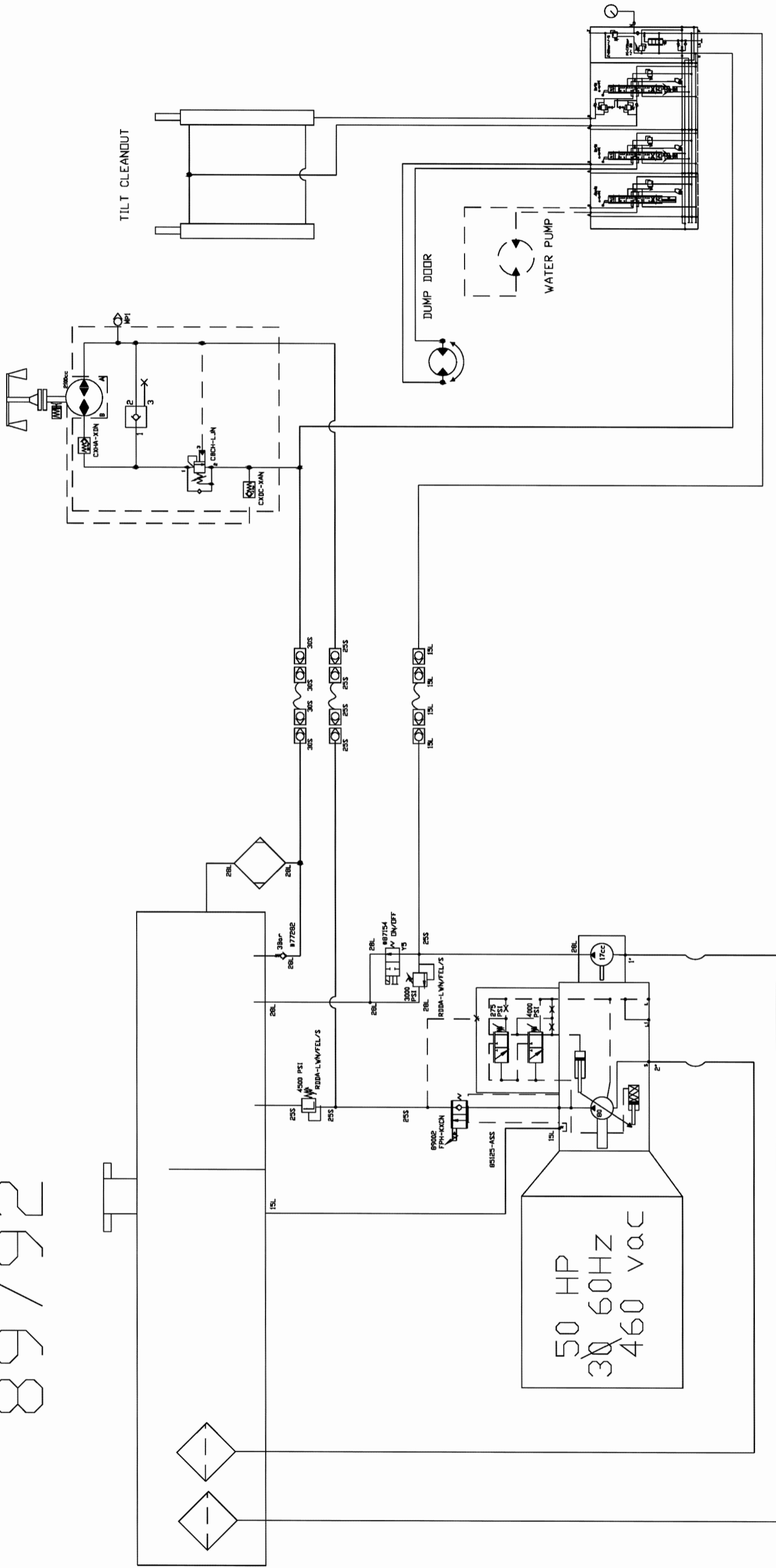

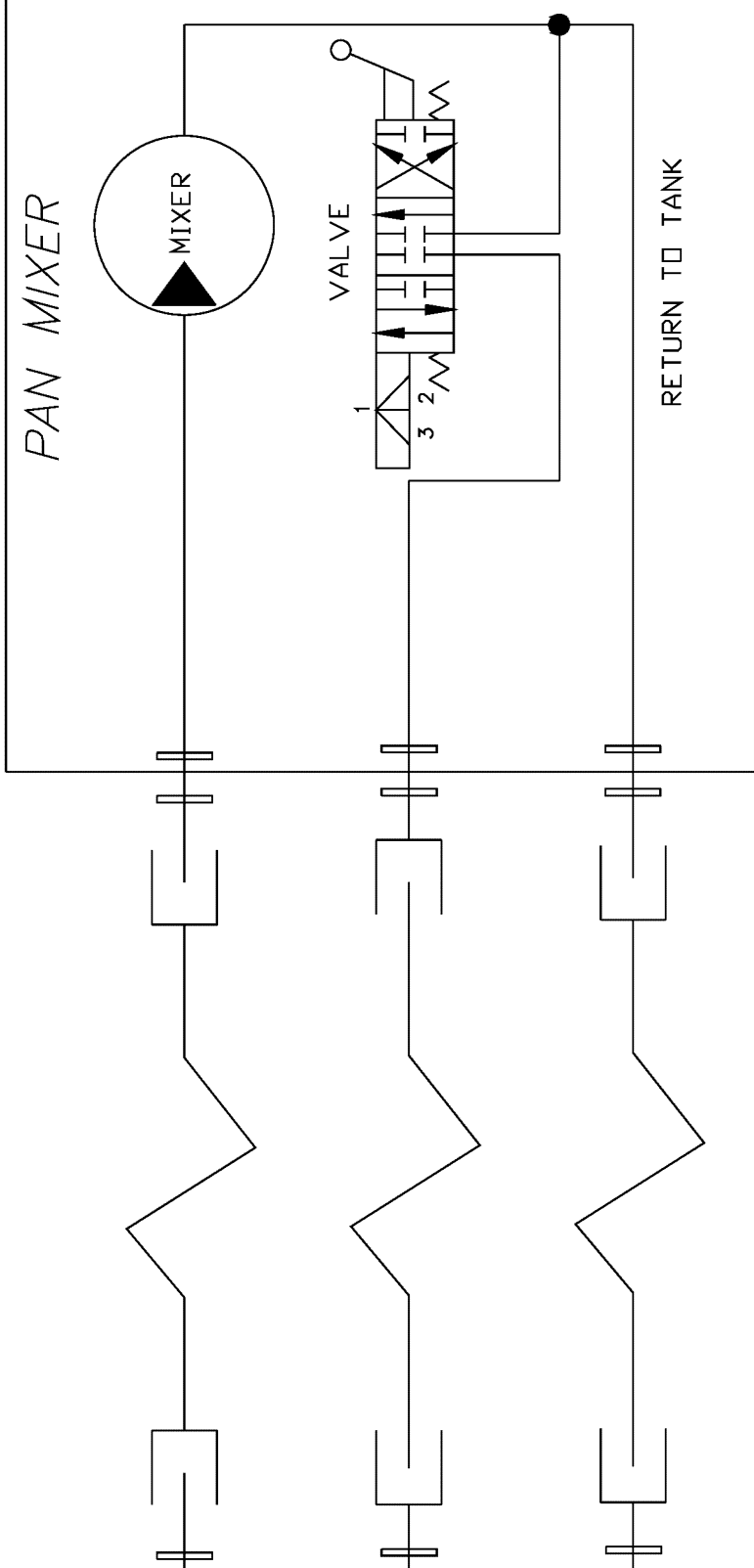
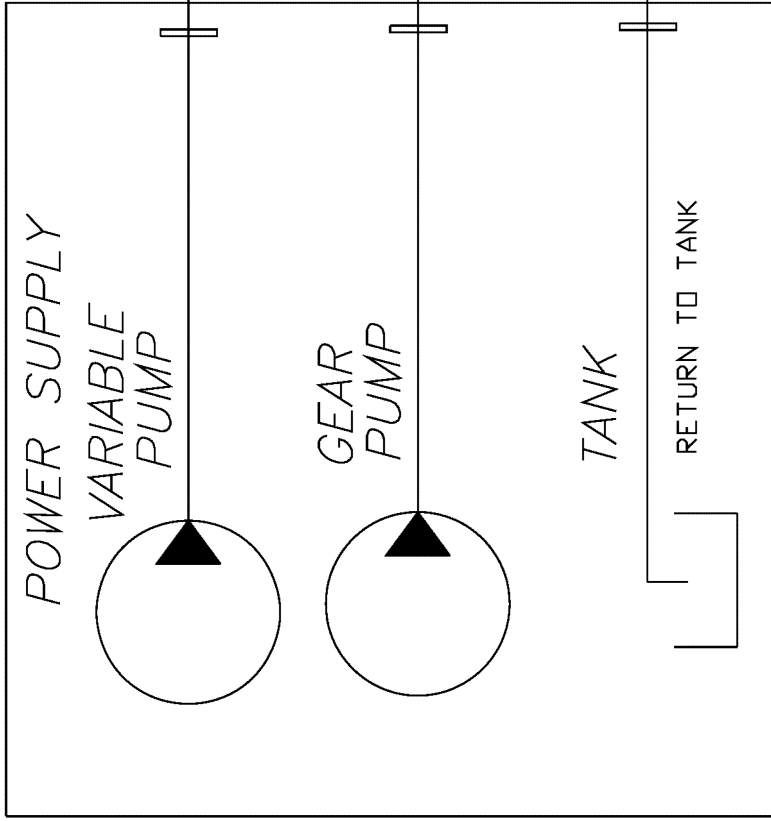

# POWER PACK HARNESS #89735

ELECTRIC POWER SUPPLY TO VALVES

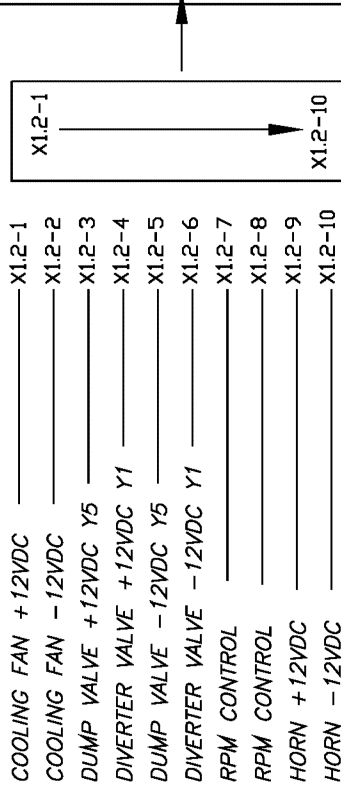

ELECTRIC POWER SUPPLY

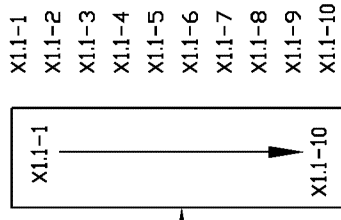

MAIN DIESEL POWER CONTROL

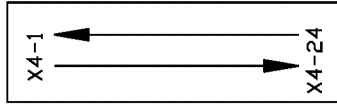

MAIN ELECTRIC CONTROL

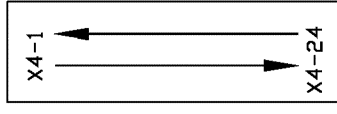

MAIN DIESEL POWER CONTROL

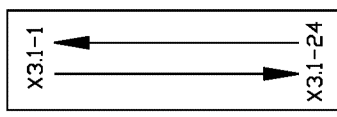

MAIN ELECTRIC CONTROL

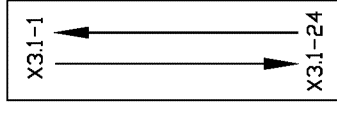

REMOVABLE CABLE

PLUG INTO CONTROL SUPPLY

CONTROL BOX

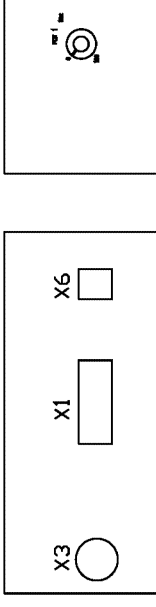

COULD BE

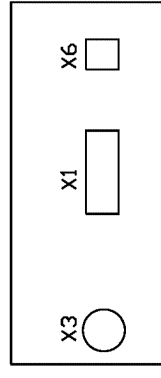

- X3-A — PROX SWITCH +12VDC
- X3-B — PROX SIGNAL 2S9
- X3-C — PROX GND.
- X3-D — HORN +12VDC
- X3-E — HORN -12VDC
- X3-F — TILT UP Y2
- X3-G — TILT DOWN Y2
- X3-H — DUMP DOOR OPEN Y3
- X3-I — DUMP DOOR CLOSE Y3
- X3-J — GROUND
- X3-K — GROUND
- X3-L — GROUND
- X3-M — GROUND
- X3-N — GROUND
- X3-O — GROUND
- X3-P — GROUND
- X3-Q — GROUND

# PAM MIXER HARNESS #89733-H

- +12VDC —
- +12VDC —
- 12VDC —
- 12VDC —
- DUMP -VALVE
- ON/OFF -VALVE
- HORN -12VDC —
- HORN +12VDC —

- (BATTERY SUPPLY) +12VDC —
- (BATTERY SUPPLY) +12VDC —
- (BATTERY SUPPLY) -12VDC —
- (BATTERY SUPPLY) -12VDC —
- DUMP -VALVE —
- ON/OFF -VALVE —
- HORN -12VDC —
- HORN +12VDC —

- X1.1-1 — X1.1-10
- X1.1-2
- X1.1-3
- X1.1-4
- X1.1-5
- X1.1-6
- X1.1-7
- X1.1-8
- X1.1-9
- X1.1-10
- X4-1 — X4-24
- X4-2
- X4-3
- X4-4
- X4-5
- X4-6
- X4-7
- X4-8
- X4-9
- X4-10
- X4-11
- X4-12
- X4-13
- X4-14
- X4-15
- X4-16
- X4-17
- X4-18
- X4-19
- X4-20
- X4-21
- X4-22
- X4-23

- X3.1-1 — X3.1-24
- X3.1-2
- X3.1-3
- X3.1-4
- X3.1-5
- X3.1-6
- X3.1-7
- X3.1-8
- X3.1-9
- X3.1-10
- X3.1-11
- X3.1-12
- X3.1-13
- X3.1-14
- X3.1-15
- X3.1-16
- X3.1-17
- X3.1-18
- X3.1-19
- X3.1-20
- X3.1-21
- X3.1-22
- X3.1-23

MALE CONNECTOR

MALE CONNECTOR

MALE CONNECTOR

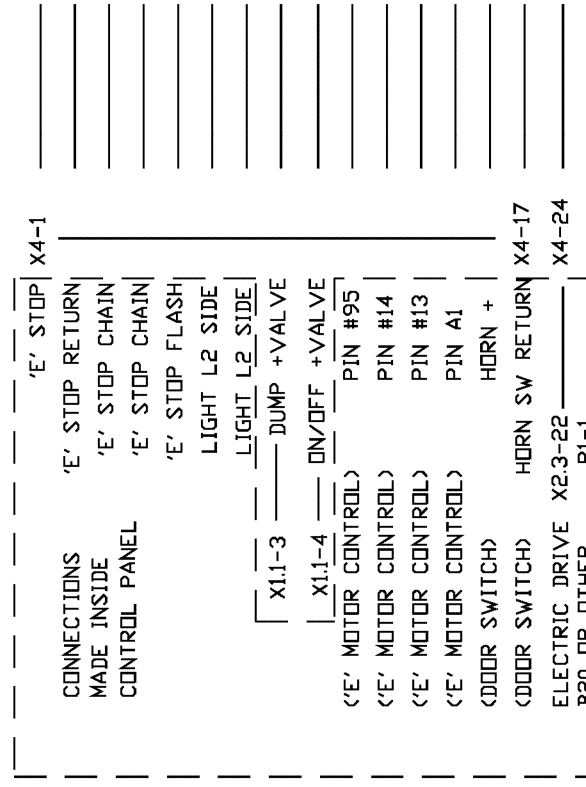

- 'E' STOP
- 'E' STOP RETURN
- 'E' STOP CHAIN
- 'E' STOP CHAIN
- 'E' STOP FLASH
- LIGHT L2 SIDE
- LIGHT L2 SIDE
- DUMP +VALVE
- ON/OFF +VALVE
- PIN #95
- PIN #14
- PIN #13
- PIN A1
- HORN +
- HORN RETURN
- 'E' STOP

- CONNECTIONS MADE INSIDE CONTROL PANEL
- X1.1-3 — DUMP +VALVE
- X1.1-4 — ON/OFF +VALVE
- (E' MOTOR CONTROL) PIN #95
- (E' MOTOR CONTROL) PIN #14
- (E' MOTOR CONTROL) PIN #13
- (E' MOTOR CONTROL) PIN A1
- (DOOR SWITCH) HORN +
- (DOOR SWITCH) HORN SW RETURN X4-17
- ELECTRIC DRIVE X2.3-22
- B20 OR OTHER PI-1

- X2-1 — X2-24
- X2-2
- X2-3
- X2-4
- X2-5
- X2-6
- X2-7
- X2-8
- X2-9
- X2-10
- X2-11
- X2-12
- X2-13
- X2-14
- X2-15
- X2-16
- X2-17
- X2-18
- X2-19
- X2-20
- X2-21
- X2-22
- X2-23

# EXTENSION CABLE #88610

- X1-1 — X1-24
- X1-2
- X1-3
- X1-4
- X1-5
- X1-6
- X1-7
- X1-8
- X1-9
- X1-10
- X1-11
- X1-12
- X1-13
- X1-14
- X1-15
- X1-16
- X1-17
- X1-18
- X1-19
- X1-20
- X1-21
- X1-22
- X1-23

CONTROL BOX

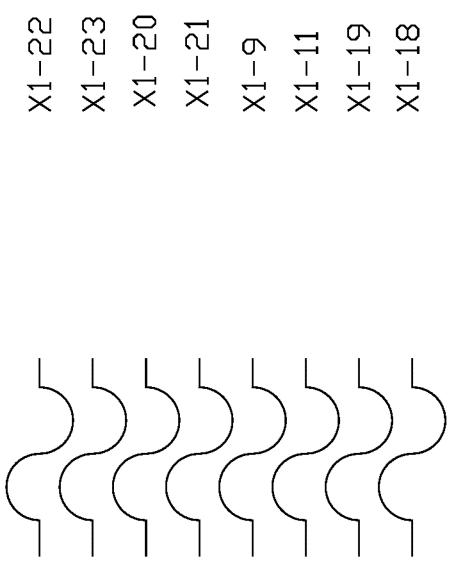

+12VDC —  
 +12VDC —  
 -12VDC —  
 -12VDC —  
 DUMP - VALVE  
 ON/OFF - VALVE  
 HORN -12VDC —  
 HORN +12VDC —

X3

PROX SWITCH +12VDC  
 PROX SIGNAL 2S9  
 PROX GND.  
 HORN +12VDC  
 HORN -12VDC  
 TILT UP Y2  
 TILT DOWN Y2  
 DUMP DOOR OPEN Y3  
 DUMP DOOR CLOSE Y3  
 GROUND  
 GROUND  
 GROUND  
 GROUND  
 GROUND

X3-A —  
 X3-B —  
 X3-C —  
 X3-D —  
 X3-E —  
 X3-F —  
 X3-G —  
 X3-H —  
 X3-J —  
 X3-K —  
 X3-L —  
 X3-M —  
 X3-N —  
 X3-O —  
 X3-P —  
 X3-Q —  
 X3-R —  
 X3-S —  
 X3-T —  
 X3-U —

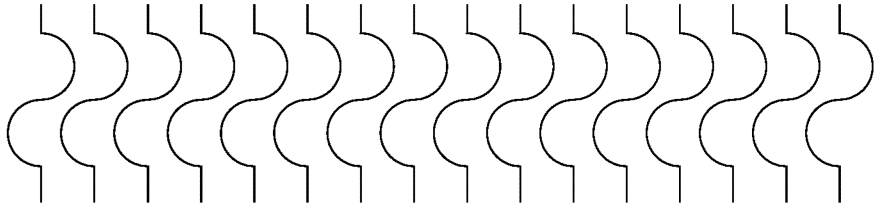

— 'E' STOP  
 — 'E' STOP RETURN  
 — 'E' STOP CHAIN  
 — 'E' STOP CHAIN  
 — 'E' STOP FLASH  
 — LIGHT L2 SIDE  
 — LIGHT L2 SIDE  
 — DUMP + VALVE  
 — ON/OFF + VALVE  
 — PIN #95  
 — PIN #14  
 — PIN #13  
 — PIN A1  
 — HORN +  
 — HORN RETURN  
 — 'E' STOP

X1-1  
 X1-2  
 X1-3  
 X1-4  
 X1-5  
 X1-6  
 X1-7  
 X1-8  
 X1-10  
 X1-12  
 X1-13  
 X1-14  
 X1-15  
 X1-16  
 X1-17  
 X1-24

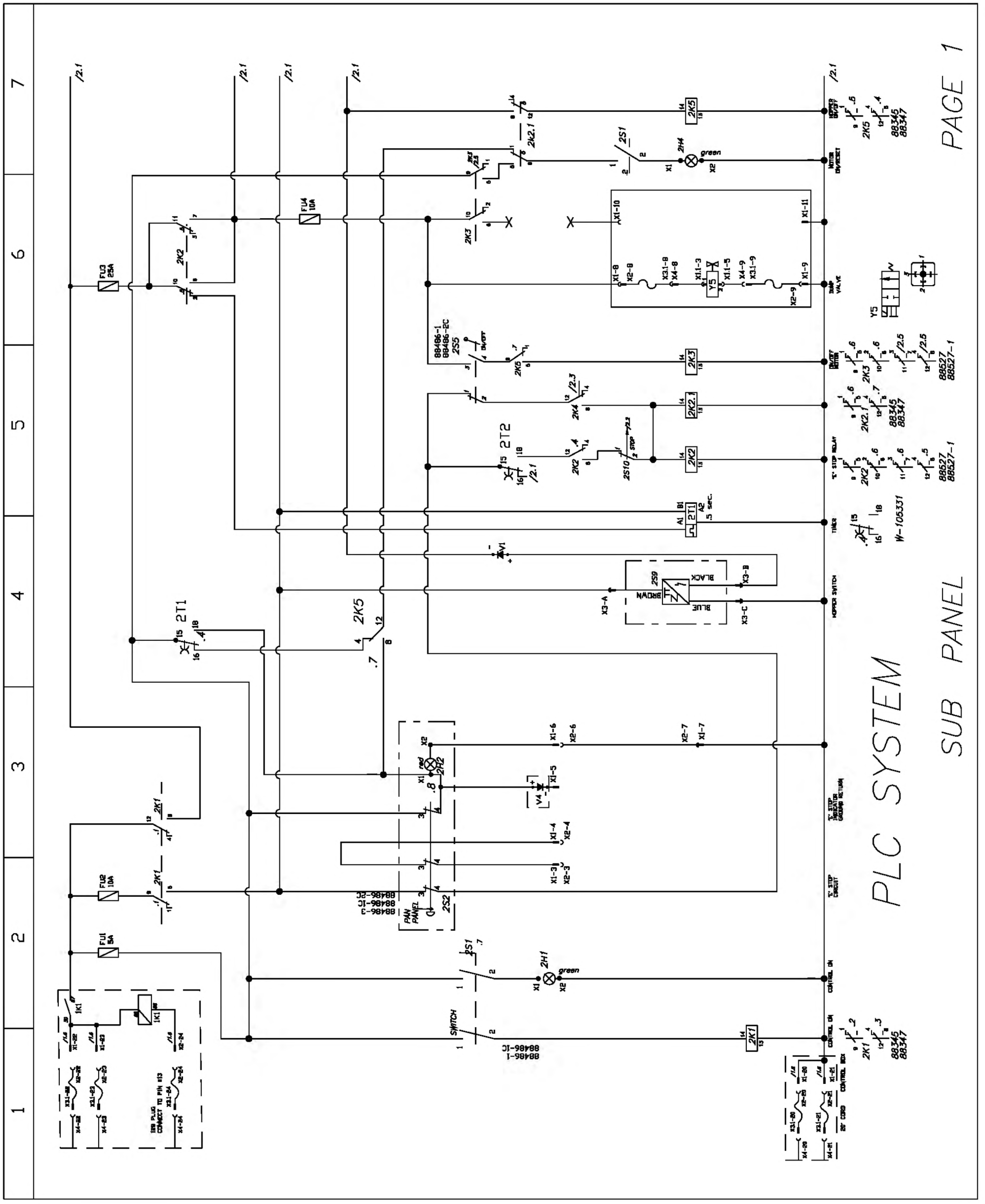

# PLC SYSTEM

## SUB PANEL

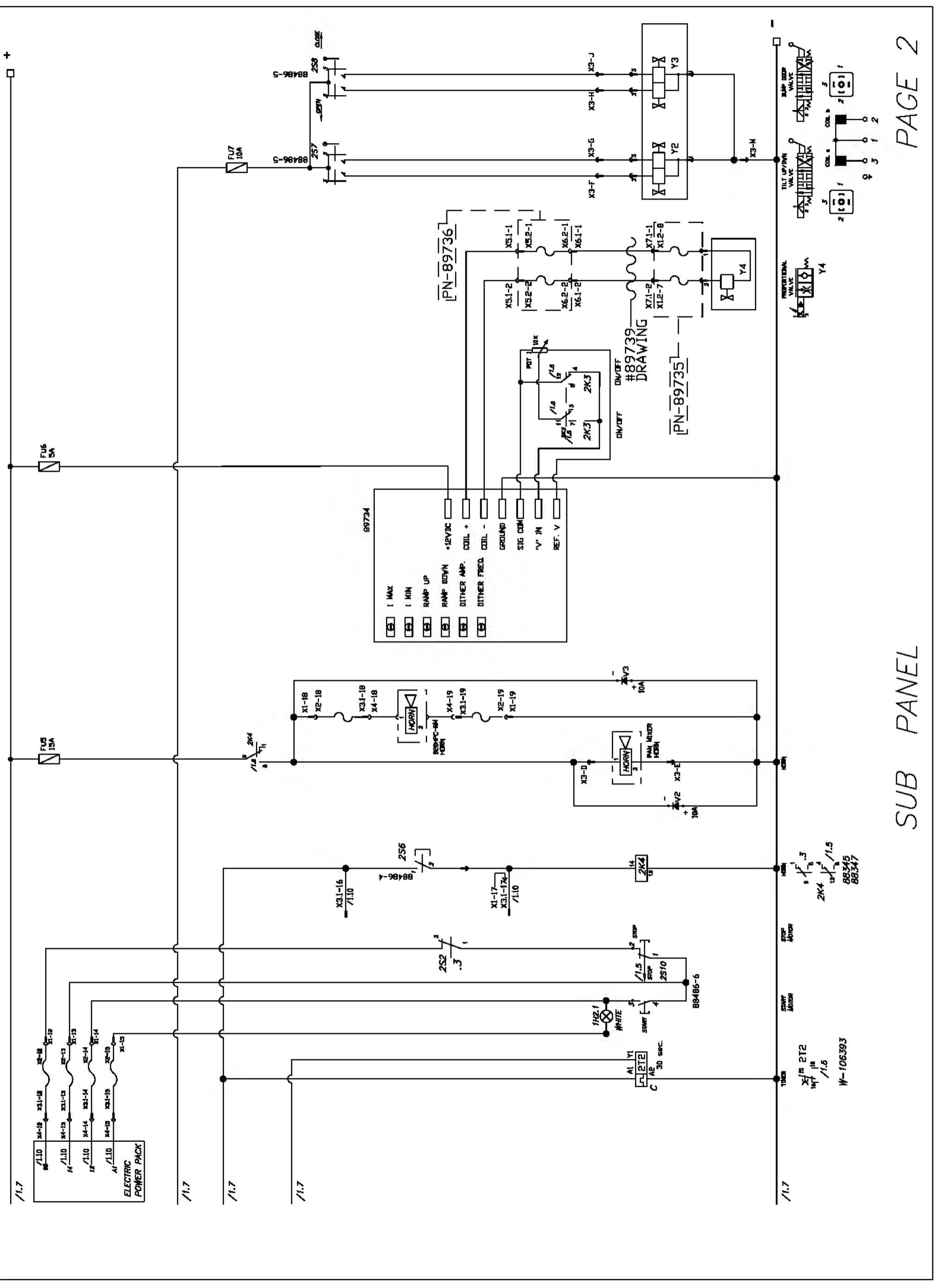

/1.7

/1.7

/1.7

/1.7

/1.7

ELECTRIC POWER PACK

99734

[S]	I MAX	+12VDC
[S]	I MIN	COIL +
[S]	RAMP UP	COIL -
[S]	RAMP DOWN	GROUND
[S]	DITHER AMP.	SIG COM
[S]	DITHER FREQ.	'V' IN
[S]		REF. V

#89739  
DRAWING

PN-89735

W-106393

88345  
88347



# 89739

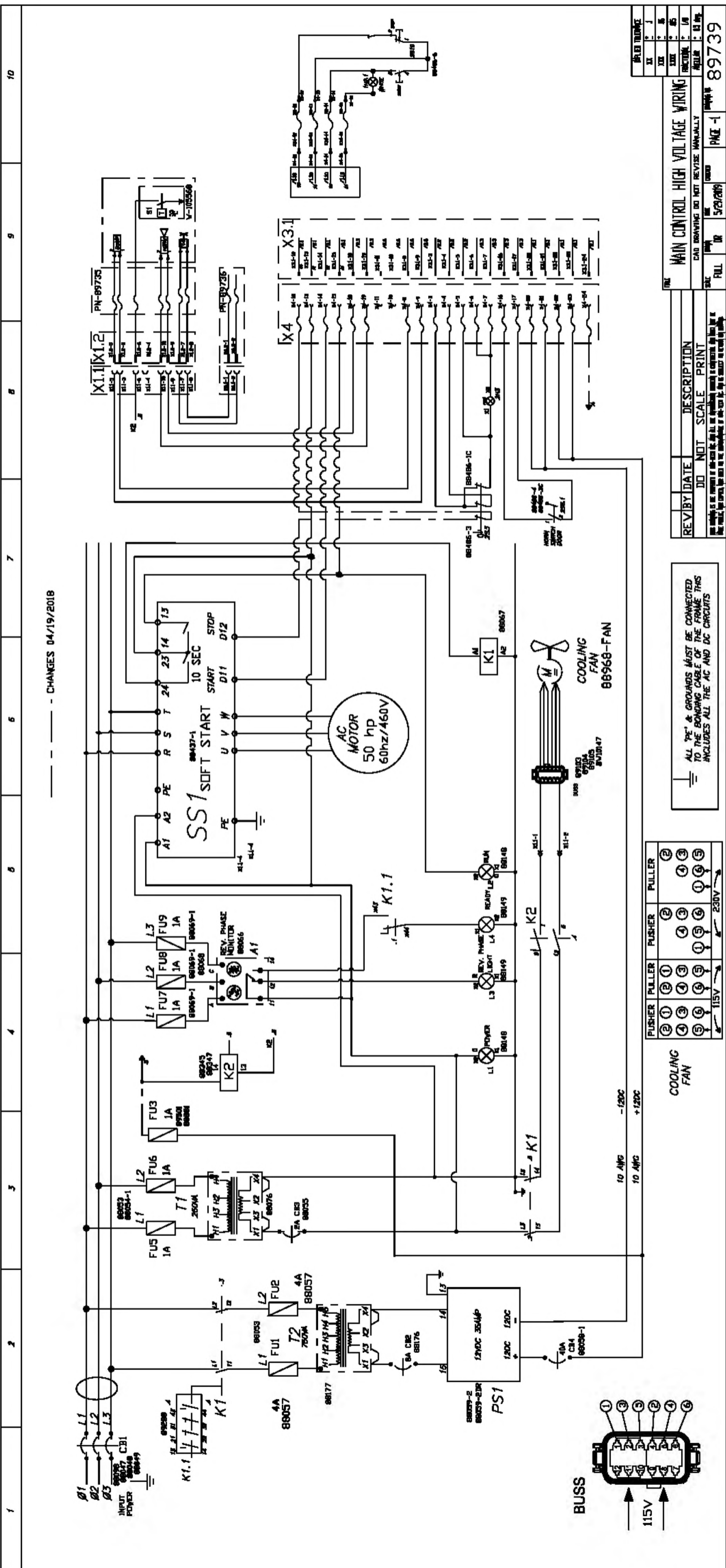

REV	BY	DATE	DESCRIPTION
1			SCALE PRINT
2			NOT REVISION

ALL PE & GROUNDS MUST BE CONNECTED TO THE BONDING CABLE OF THE FRAME THIS INCLUDES ALL THE AC AND DC CIRCUITS

PULLER		PUSHER		PULLER	
1	2	1	2	1	2
3	4	3	4	3	4
5	6	5	6	5	6

NO.	DESCRIPTION	SCALE	PRINT
1	115V		
2	10 AVG		
3	120C		
4	120C		
5	120C		
6	120C		

# REED

## WIRING HARNESS PAN MIXER

B-SERIES

SCMTC

PAGE 1 of 1

DRAWING NO.  
89733-H

REV

DATE  
5/17/19

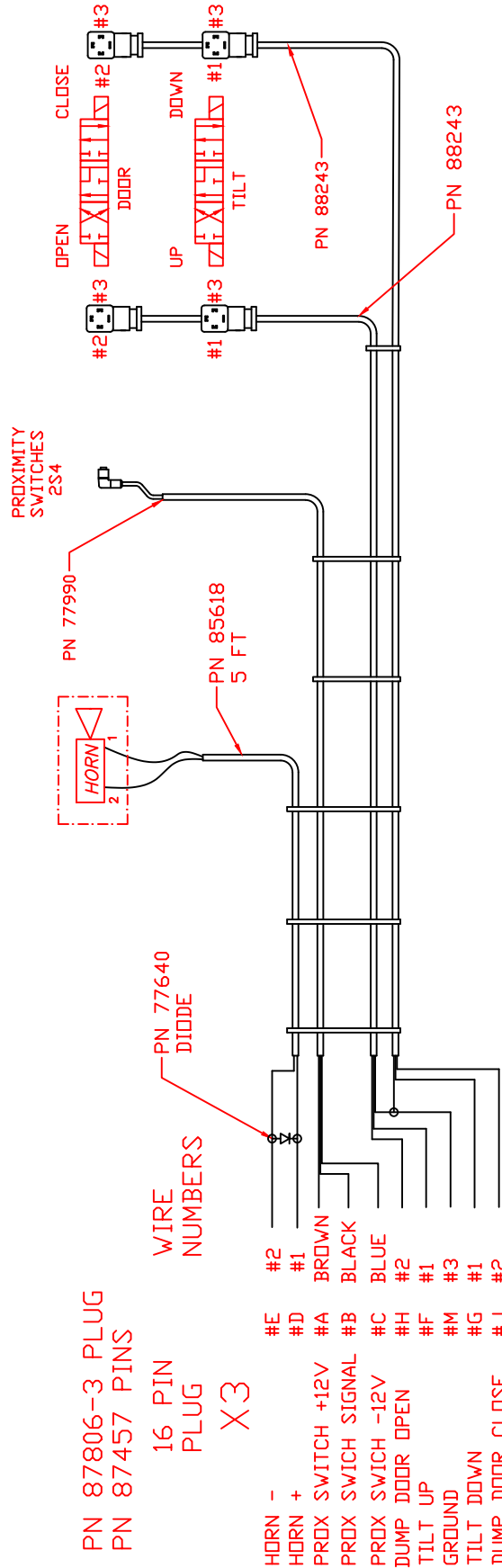



# RP2200

## PARTS



(909)287-2100

PARTS.....2

    FRAME ASSEMBLY .....2

MAIN HYDRAULIC GEAR PUMP .....3

    PUMP DRIVE .....3

    POWER TRAIN.....3

    ELECTRIC MOTOR / COUPLING .....4

    HYDRAULIC TANK ASSEMBLY .....5

ELECTRICAL CONNECTION .....7

    WIRING HARNESS .....8

MAIN ELECTRICAL PANEL.....9

    CONNECTORS .....12

AVAILABLE OPTIONS ..... **ERROR! BOOKMARK NOT DEFINED.**

REV	DATE	DESCRIPTION	NAME
RP2200-V05	11/12/19	INITIAL *	J.SLACK

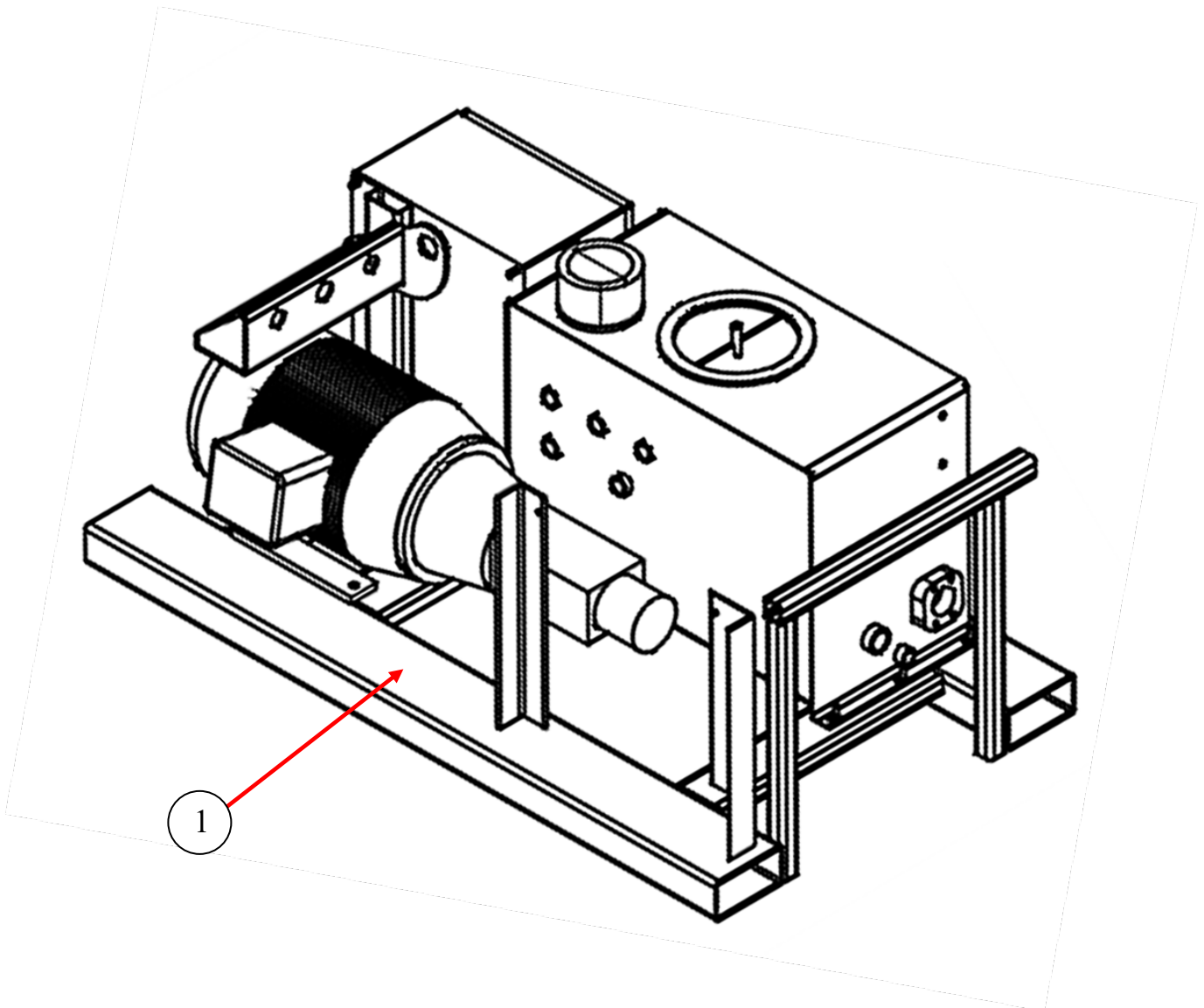
PARTS  
FRAME ASSEMBLY

ID #	PART #	PART DESCRIPTION	QUANTITY	
	89676	FRAME WELDMENT, PAN MIXER		EA

### MAIN HYDRAULIC GEAR PUMP PUMP DRIVE

**Kawasaki**  
Hydraulics

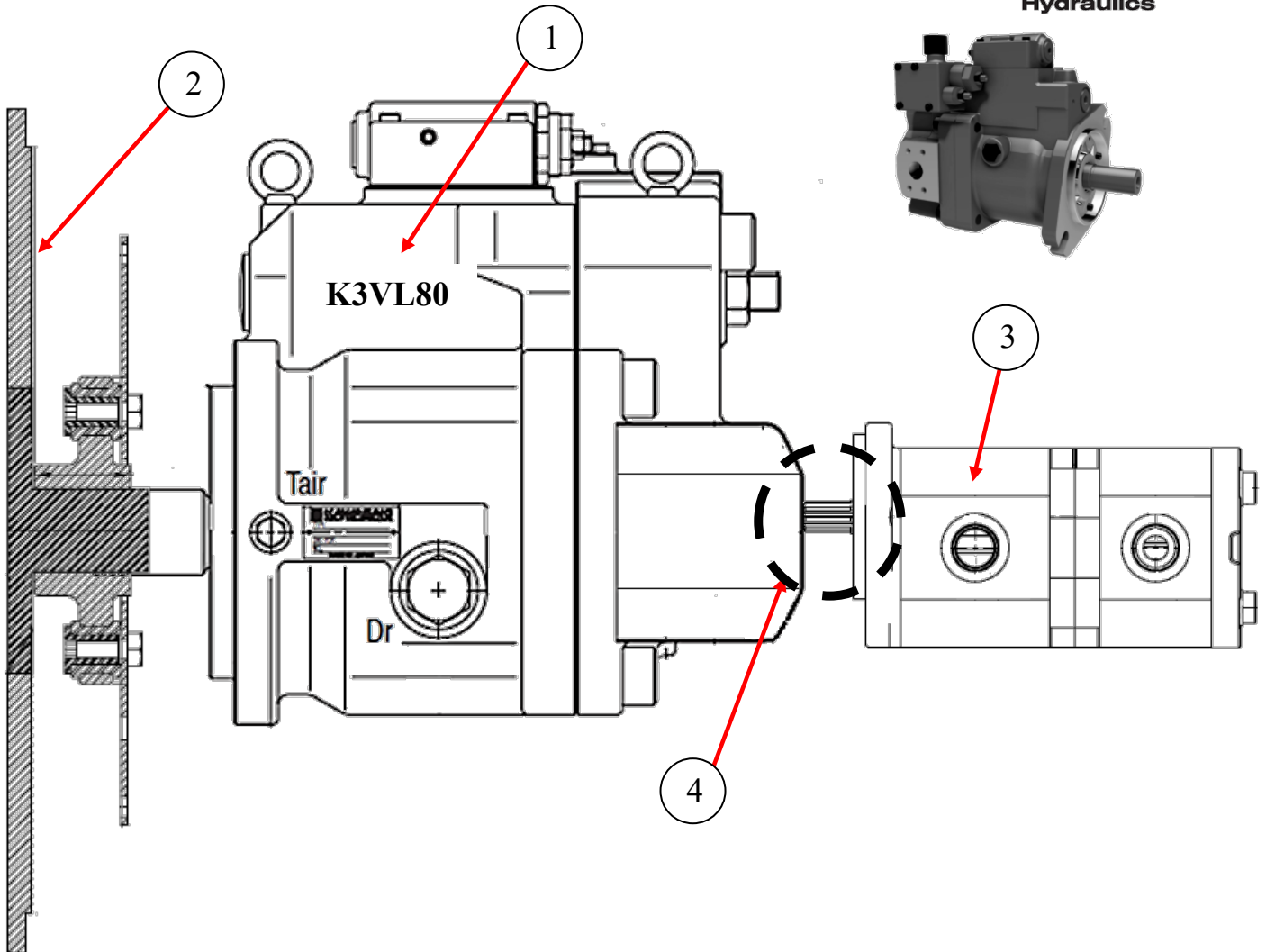

ID #	PART #	PART DESCRIPTION	QUANTITY	
1	79560-K	PUMP, KV3L80 KAWASAKI, 62HP	1	EA
2	72266	PUMP DRIVE -324/326TC/SAE-C	1	EA
3	88614	PUMP-GEAR PUMP 33CC RH, SAE-A MOUNT	1	EA
4	74017	O-RING #232	1	EA

### POWER TRAIN ELECTRIC MOTOR / COUPLING

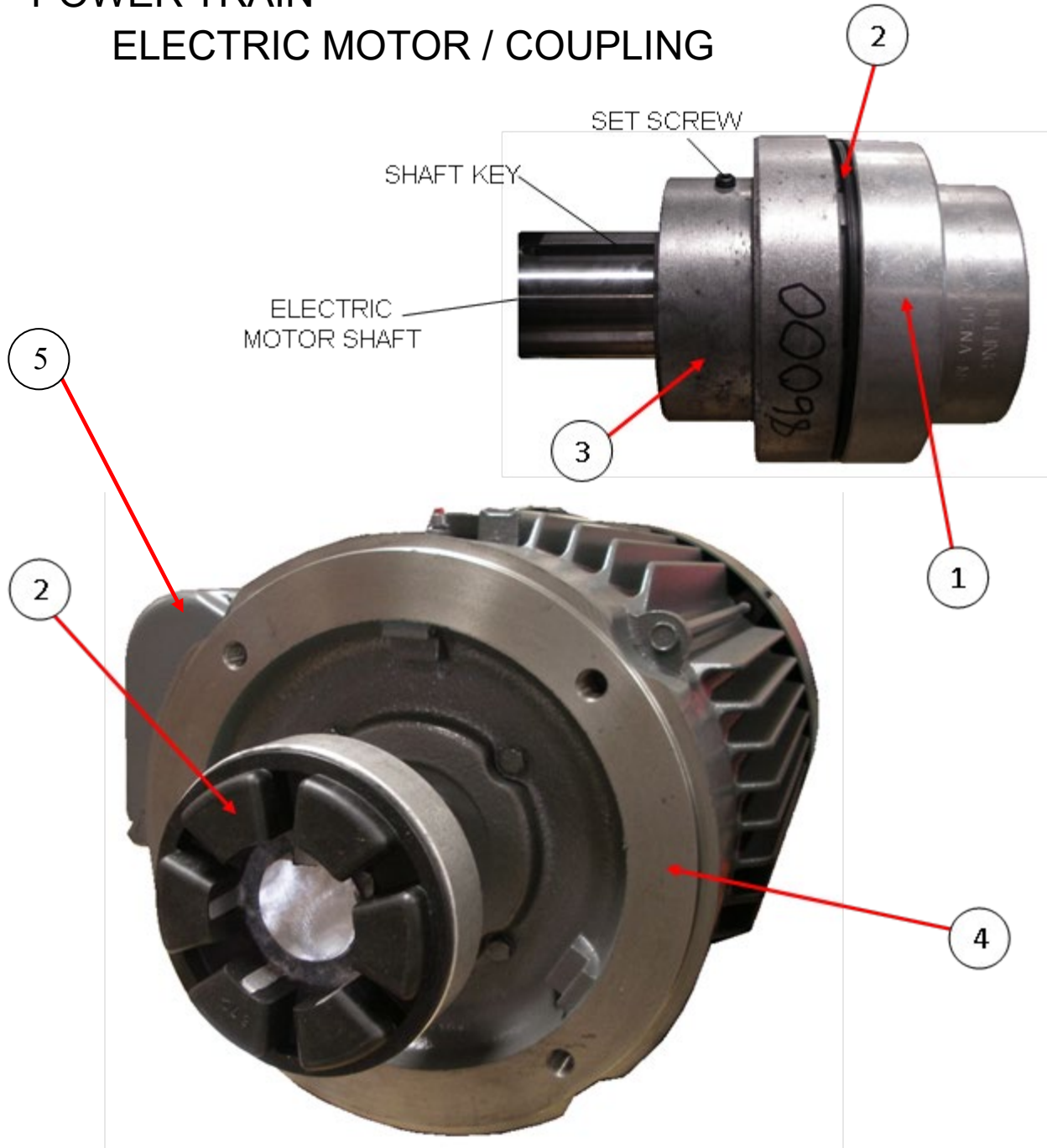

ID #	PART #	PART DESCRIPTION	QUANTITY	
1	87040	COUPLING HALF, PUMP SHAFT	1	EA
2	86002	COUPLING SPIDER, L190-NBR (USE P/N 87041)	1	EA
3	86000	COUPLING HALF, L190-2 1/2X1/2 (USE P/N 87039)	1	EA
4	85991	MOTOR, 50HP, 460V, 60HZ, 3PH,	1	EA
5	88928	TERMINAL BLOCK FOR WEG MOTOR CE CONN.	1	EA



### HYDRAULIC TANK ASSEMBLY

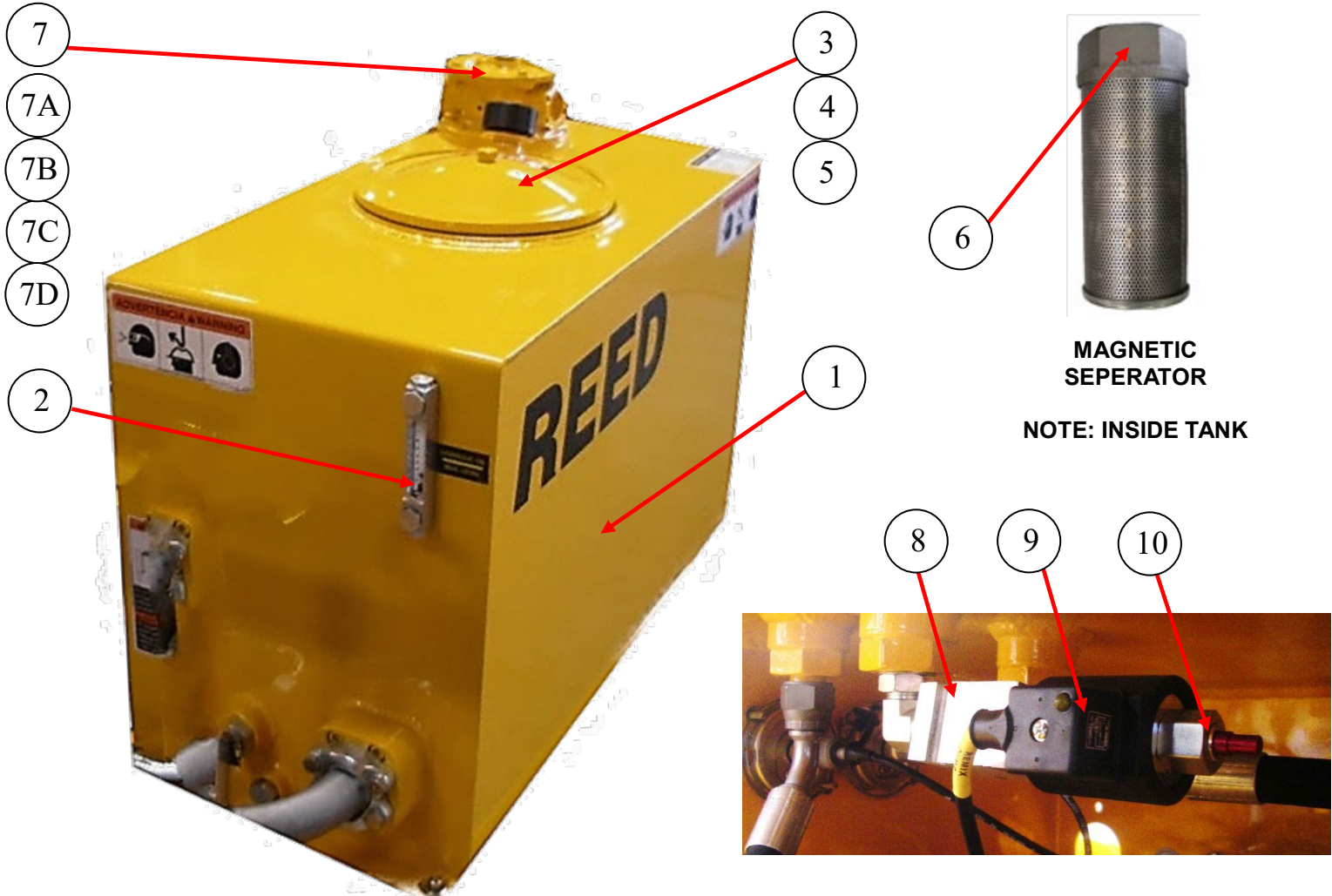

**MAGNETIC SEPERATOR**

**NOTE: INSIDE TANK**

ID #	PART #	PART DESCRIPTION	QUANTITY	
1	88449	OIL TANK WELDMENT	1	EA
2	74509	GAUGE-SIGHT/TEMPERATURE	1	EA
3	85537	FILLER BREATHER, 3/4 NPT	1	EA
4	85529	ENDCOVER KIT, 12 IN W/DRAIN	1	EA
5	85867	GASKET- END COVER 12"	1	EA
6	800230	MAGNETIC SEPARATOR,3"NPT	1	EA
7	85282	FILTER, RETURN, TANK MOUNTED	1	EA
7A	BW10241	SEAL KIT FOR 85282 FILTER RETURN	1	EA
7B	85282-G	GASKET-CORK	1	EA
7C		FILTER ELEMENT, PN 85282 FILTER	1	EA
7D	85575	GAUGE, PN 85282 RETURN FILTER	1	EA
8	87154	SOLENOID VALVE ASSY	1	EA
9	87155	COIL	1	A/R
10	87155-C	CARTRIDGE	1	A/R

## HYDRAULIC ASSEMBLY

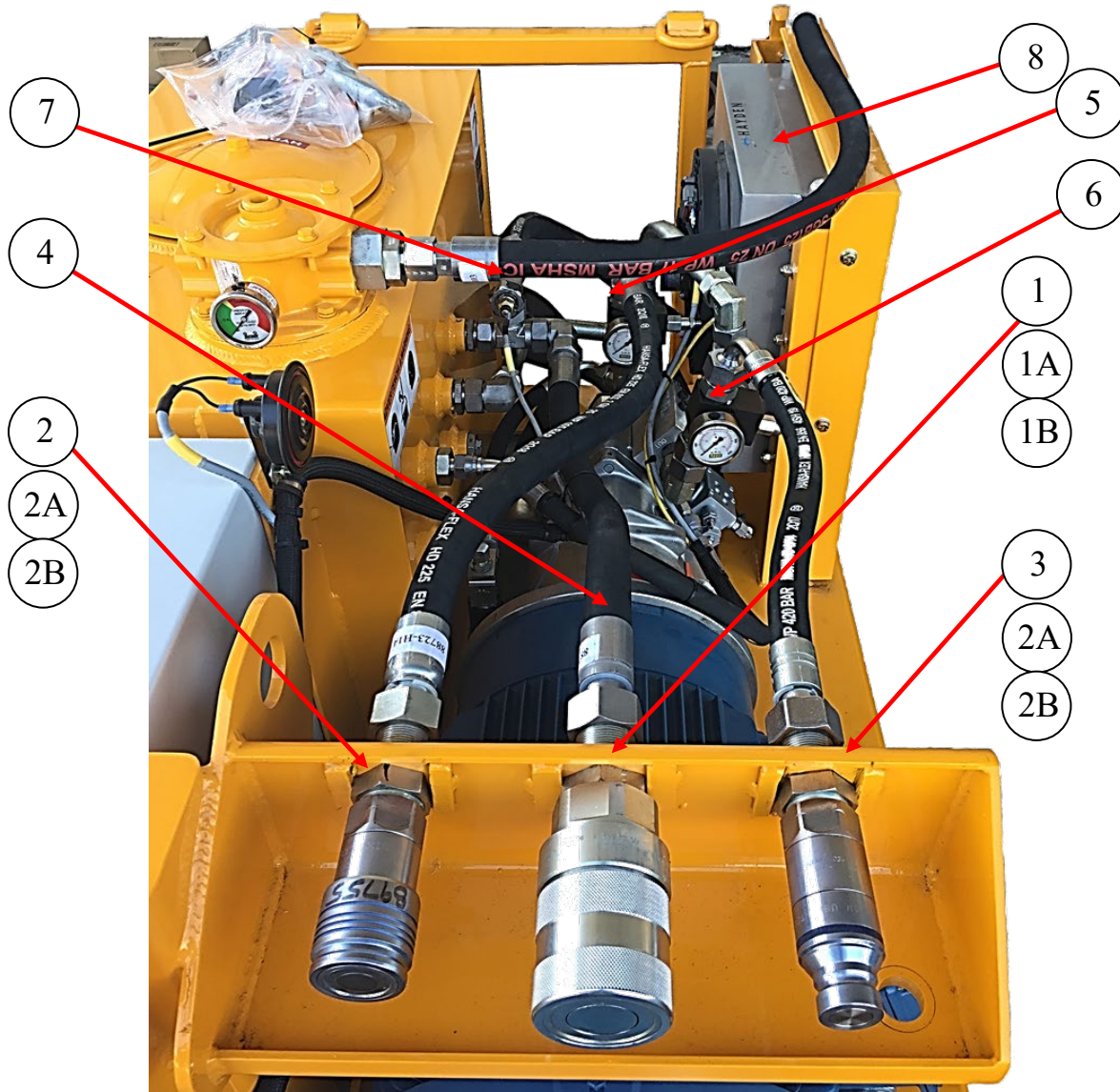

ID #	PART #	PART DESCRIPTION	QUANTITY	
1	89755-1	COUPLER 1.5" QUICK DISCONNECT	1	EA
1A	89400-1	BULKHEAD, MALE ADAPTER SAE24-30S	1	EA
1B	89454-1	LOCK NUT M42X2, FOR 30S BULKHEAD	1	EA
2	89755	COUPLER 1" QUICK DISCONNECT	1	EA
2A	89400	BULKHEAD, MALE ADAPTER SAE16-25S	2	EA
2B	89454	LOCK NUT M36X2, FOR 25S BULKHEAD	2	EA
3	89754	PLUG 1" QUICK DISCONNECT	1	EA
4	88723	HOSE KIT FOR PAN MIXER POWER PACK	KIT	
5	70366	PRESSURE GAUGE, 3000 PSI/BAR	1	EA
6	74562	PRESSURE GAUGE, 6000 PSI/BAR	1	EA
7	W-105568	THERMAL SENSOR, 55 DEG.	1	EA
8	88968	HYDRAULIC OIL COOLER-ELEC 115/230 VAC	1	EA

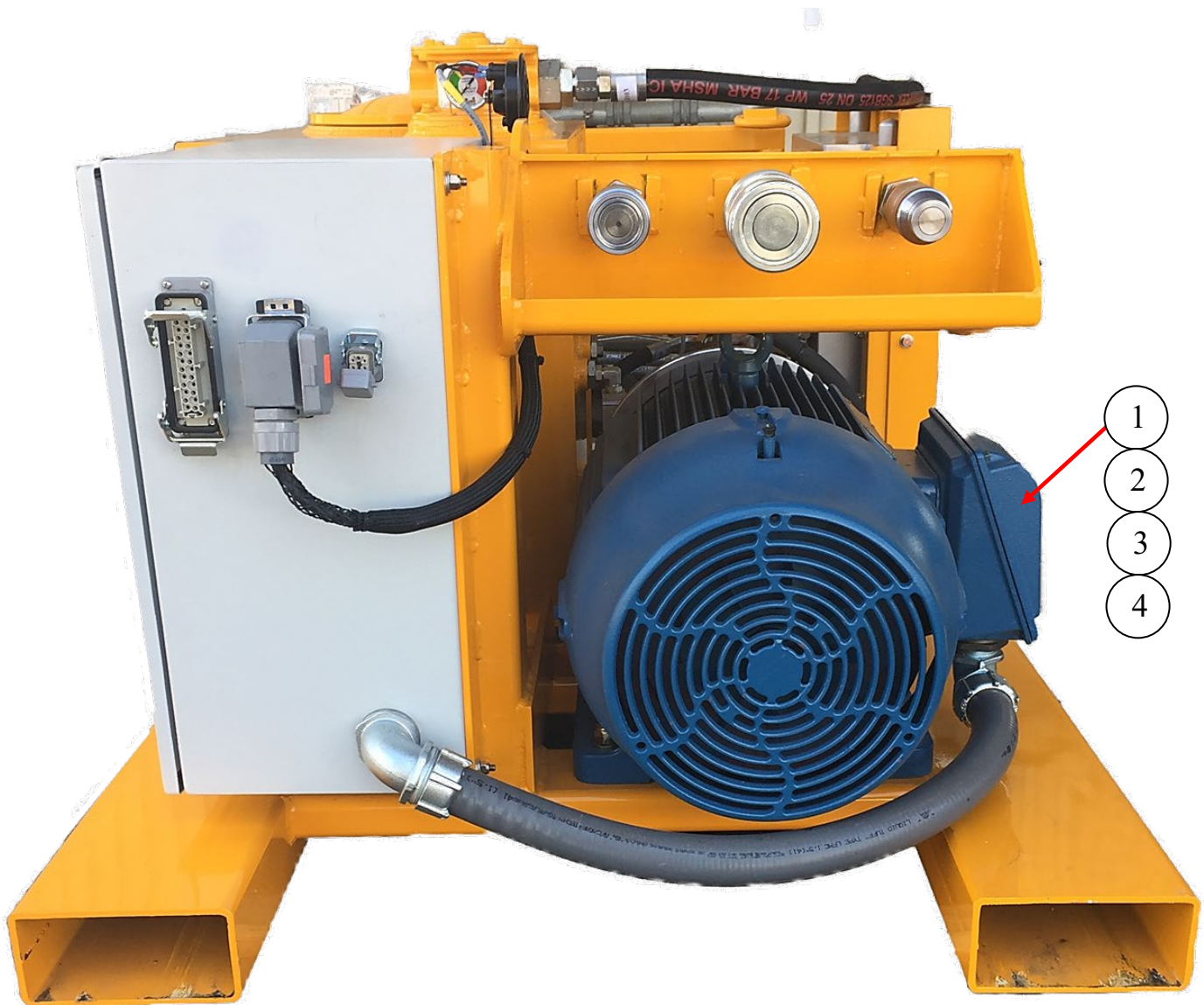

**ELECTRICAL CONNECTION**

ID #	PART #	PART DESCRIPTION	QUANTITY	
1	86523	CABLE-2 AWG NEC TYPE (MTW & THW)	15	FT.
2	86519	CONNECTOR-1 ½ IN.	2	EA
3	86520	INSULATED BUSHING-1 ½ IN.	1	EA
4	89150-2	LUG COPPER 1AWG STR W/3/8 HOLE	4	EA

**WIRING HARNESS**

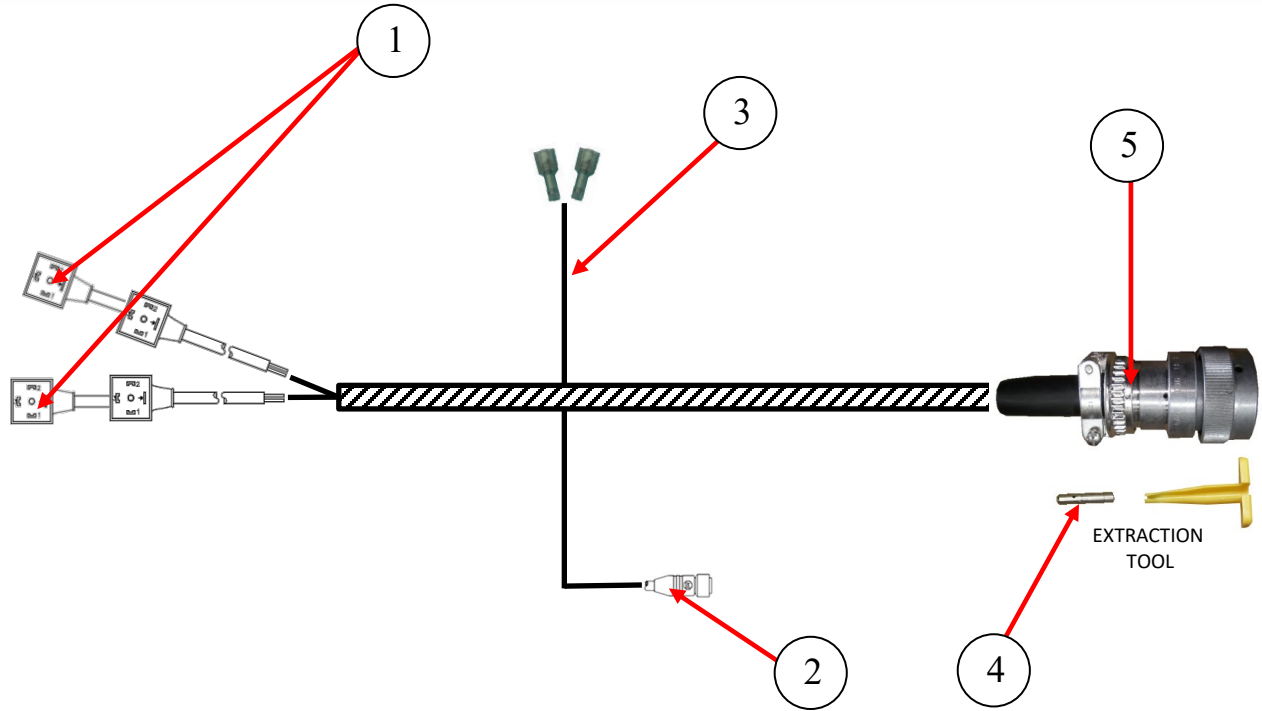

ID #	PART #	PART DESCRIPTION	QUANTITY	
	89733-H	HARNESS, MAIN, PAN MIXER	REF	
1	88243	CABLE W/2DIN PLUG	2	EA
2	77990	CABLE, PROXIMITY SWITCH	1	EA
3	85618	CABLE, 16AWG-2C, PVC-GRY	5	FT
4	87457	PIN, FOR 87456 PLUG	16	EA
5	87806-3	PLUG CONNECTOR, 16 PIN W/CORD GRIP	1	EA

## MAIN ELECTRICAL PANEL

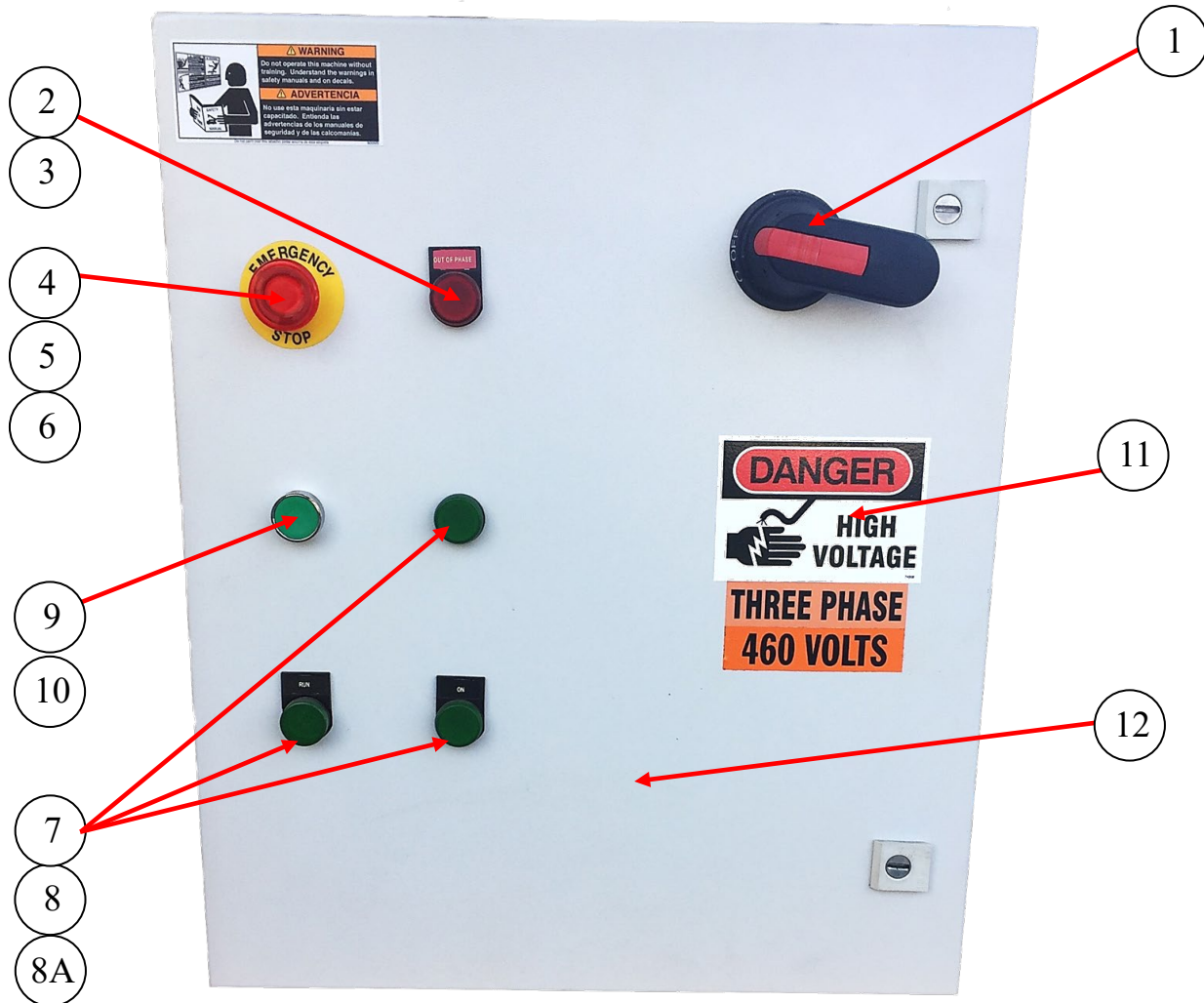

ID #	PART #	PART DESCRIPTION	QUANTITY	
	89739	CONTROL PANEL PAN MIXER / SPEED CONTROL	REF	
1	88047	HANDLE FOR 88046 CIRCUIT BREAKER	1	EA
2	88149-1	LABEL PLATE (OUT OF PHASE)	1	EA
3	88149	LED INDICATING LIGHT, (RED)	1	EA
4	88486-3	PUSHBUTTON RED 22M LED TWIST LOCK (E-STOP)	1	EA
5	88486-1C	N.O. CONTACT BLOCK	1	EA
6	88486-2C	N.C. CONTACT BLOCK	1	EA
7	88148	LED INDICATING LIGHT, (GREEN)	3	EA
8	88148-1	LABEL PLATE (RUN)	1	EA
8A		LABEL PLATE (ON)	1	EA
9	88486-4	PUSH BUTTON GREEN, 22M MOMENTARY (HORN)	1	EA
11	74306	HIGH VOLTAGE DECAL	1	EA
12	88246	ENCLOSURE 24-20-12" NEMA-4	1	EA



## MAIN ELECTRICAL PANEL

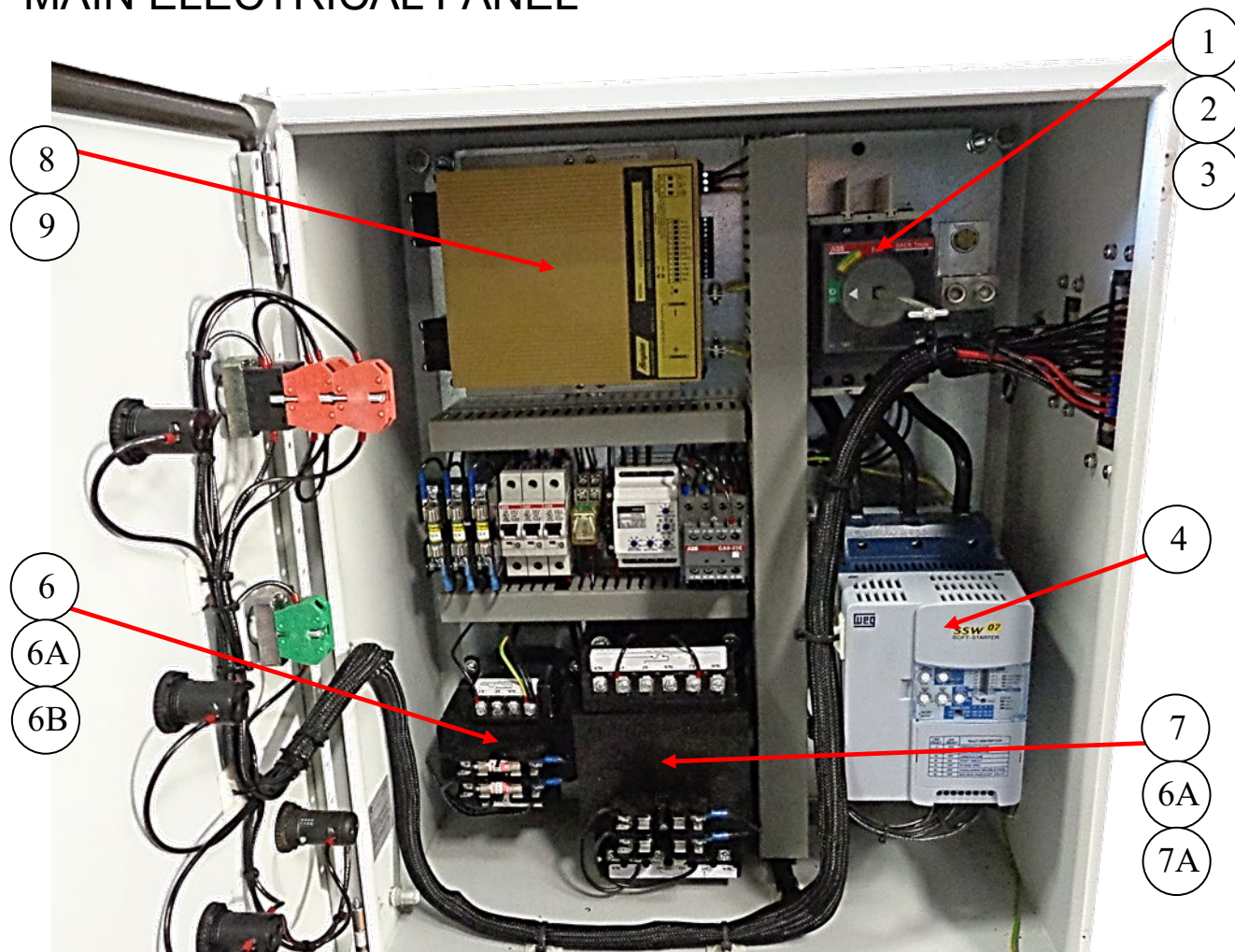

ID #	PART #	PART DESCRIPTION	QUANTITY	
		CONTROL PANEL PAN MIXER / SPEED CONTROL	REF	
1	88098	CIRCUIT BREAKER 100 AMP	1	EA
2	88048	MECHANISM FOR 88047	1	EA
3	88049	SHAFT FOR 88047 HANDLE (8 1/4" LONG)	1	EA
4	88437-1	SOFT START (SS1)	1	EA
5		DIN RAIL		EA
6	88076	TRANSFORMER 250VA, 230/460V-120V	1	EA
6A	88053	FUSE BLOCK KIT	2	EA
6B	88054-1	FUSE 1 AMP	2	EA
7	88177	TRANSFORMER 750VA, 230/460V-120V	1	EA
7A	88057	FUSE 4 AMP	2	EA
8	88059-2	POWER SUPPLY 12VDC, 35AMP ACOPIAN	1	EA
9	88059-2DR	DIN RAIL KIT FOR88059-1	2	EA
10		GROUND BLOCK		EA
11	88247	PANEL FOR 88246 ENCLOSURE	1	EA



## MAIN ELECTRICAL PANEL

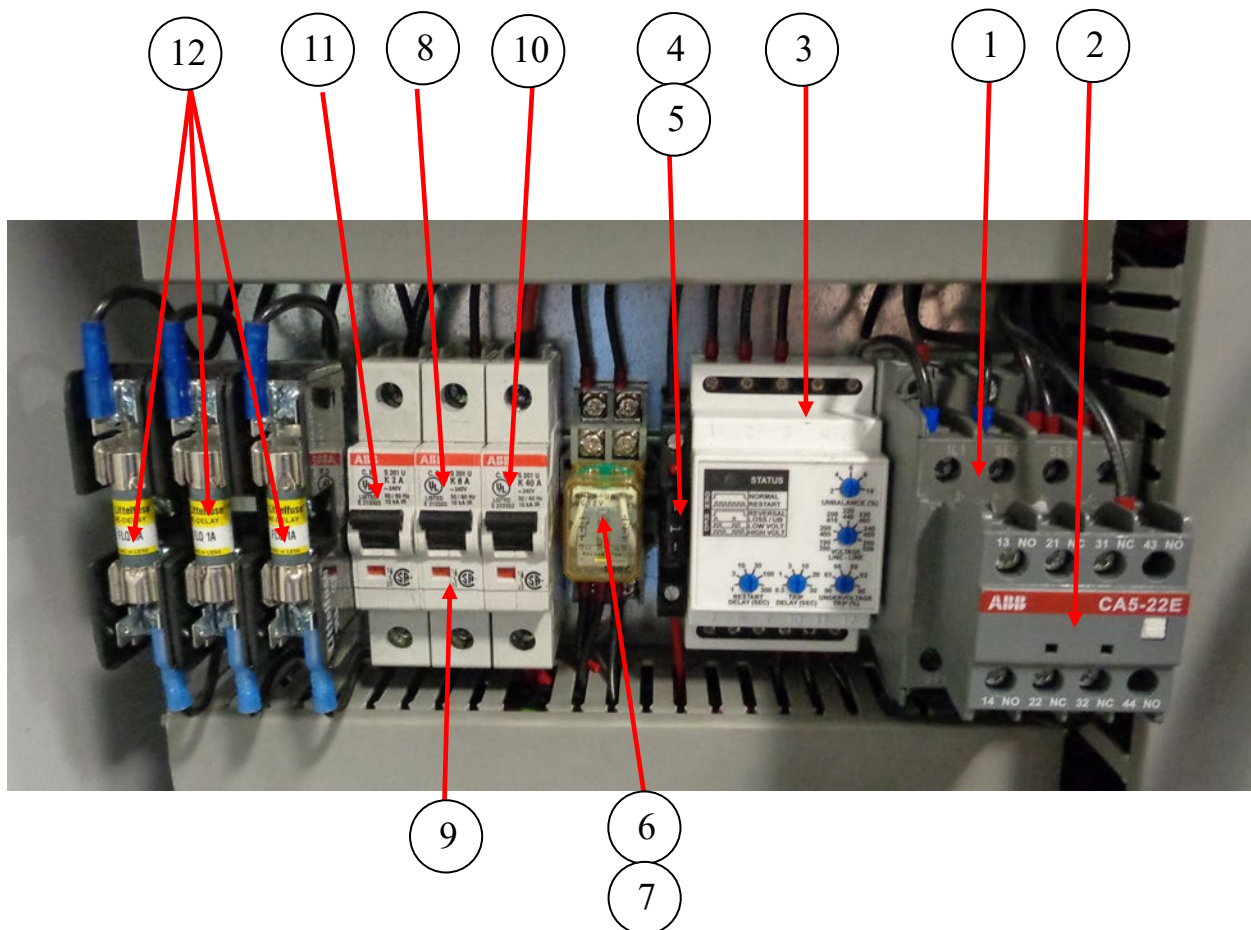

ID #	PART #	PART DESCRIPTION	QUANTITY	
		CONTROL PANEL PAN MIXER / SPEED CONTROL	REF	
1	88067	CONTACTOR (K1)	1	EA
2	89288	(K1.1)	1	EA
3	88066	RELAY REVERSE PHASE MONITOR	1	EA
4	89501	FUSE 1AMP	1	EA
5	88881	FUSE HOLDER	1	EA
6	88345-1	RELAY 12V 2 POLE	1	EA
7	88347	RELAY BASE	1	EA
8	88055	CIRCUIT BREAKER, 2 AMP		EA
9	88179	CIRCUIT BREAKER, 8 AMP	2	EA
10	88058-1	CIRCUIT BREAKER, 40 AMP	1	EA
11	88068	FUSE BLOCK	2	EA
12	88069-1	FUSE 1A (FLQ)	3	EA

**CONNECTORS**

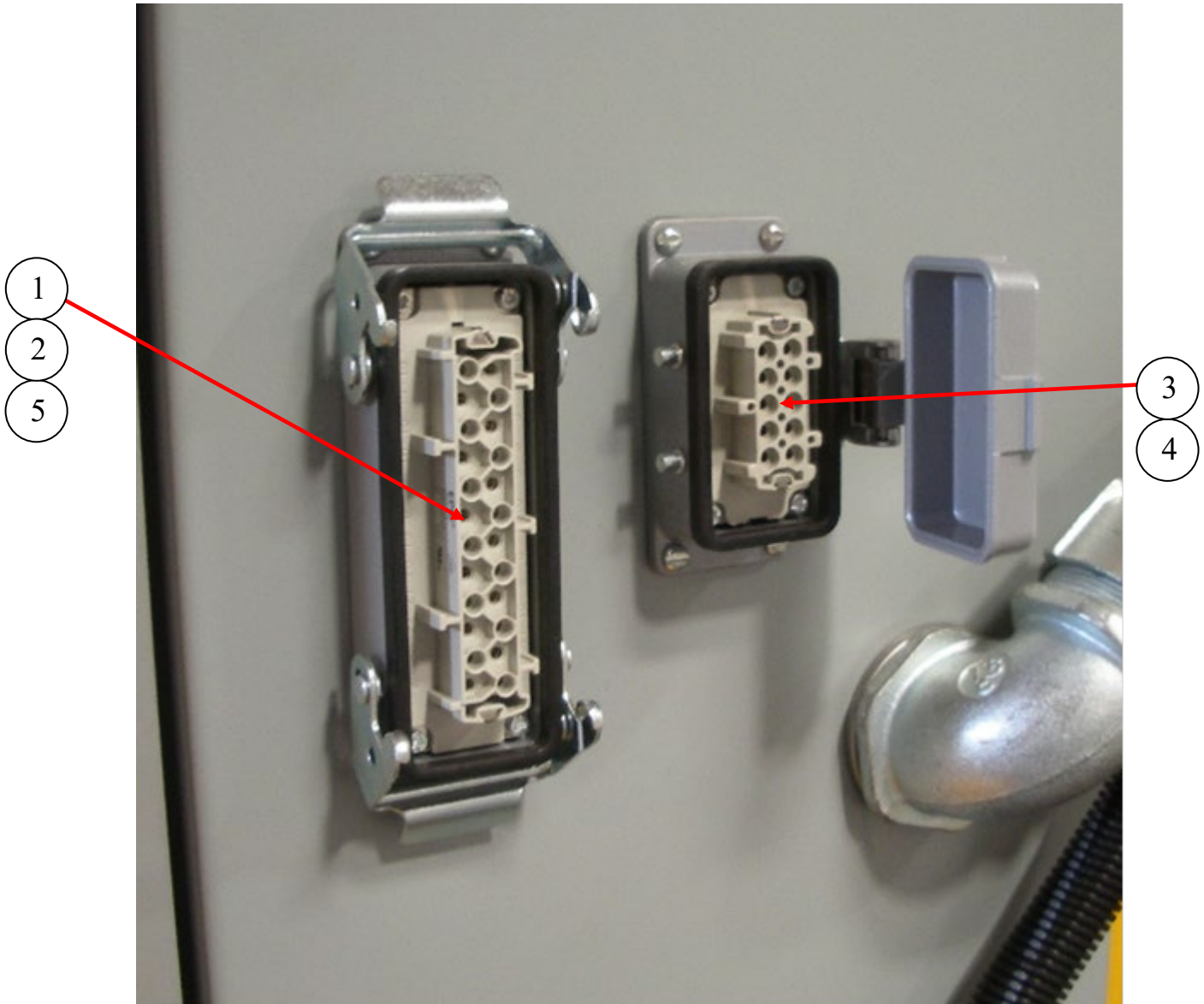

ID #	PART #	PART DESCRIPTION	QUANTITY	
1	78696	N. CONN INSERT, 24P FEMALE	1	EA
2	78697	N CONN. BASE LATCH, 24P	1	EA
3	79963	N CONN. INSERT, 10P FEMALE.	1	EA
4	79965	N. CONN. BASE-PIN, 10P	1	EA
		8-32 X 1" SCREWS (MOUNTING HARDWARE)	8	EA
		8-32 LOCKNUTS (MOUNTING HARDWARE)	8	EA
5	10118000	24 PIN COVER	1	EA



# RM2200 PARTS



(909)287-2100

PARTS.....2

PAN MIXER .....2

    MIXING BLADES .....2

    BAG BREAKER/SAFTEY GRATE .....3

    SINGLE DOOR ASSEMBLY .....4

    MAIN SHAFT ASSEMBLY .....5

    MAIN HYDAULIC MANIFOLD .....6

    MAIN HYDAULIC MANIFOLD SCHEMATIC .....7

    FRAME ASSEMBLY .....8

    LIFT CYLINDER .....9

    HYDRAULIC VALVE .....10

    CLEAN-OUT DOOR ASSEMBLY.....11

    PANEL WIRING HARNESS .....12

    MAIN CONNECTION WIRING HARNESS .....13

MAIN CONTROLS .....14

    CONTROL PANEL .....14

        FUSE, DIODE, GROUND BLOCK .....15

        RELAY, TIMER .....16

        RELAY, TIMER, CONTROLER.....17

        PLUG, CONNECTOR .....18

    AVAILABLE OPTIONS .....19

REV	DATE	DESCRIPTION	NAME
RM2200-V04	6/22/2020	INITIAL *	J.SLACK

## PARTS

### PAN MIXER

### MIXING BLADES

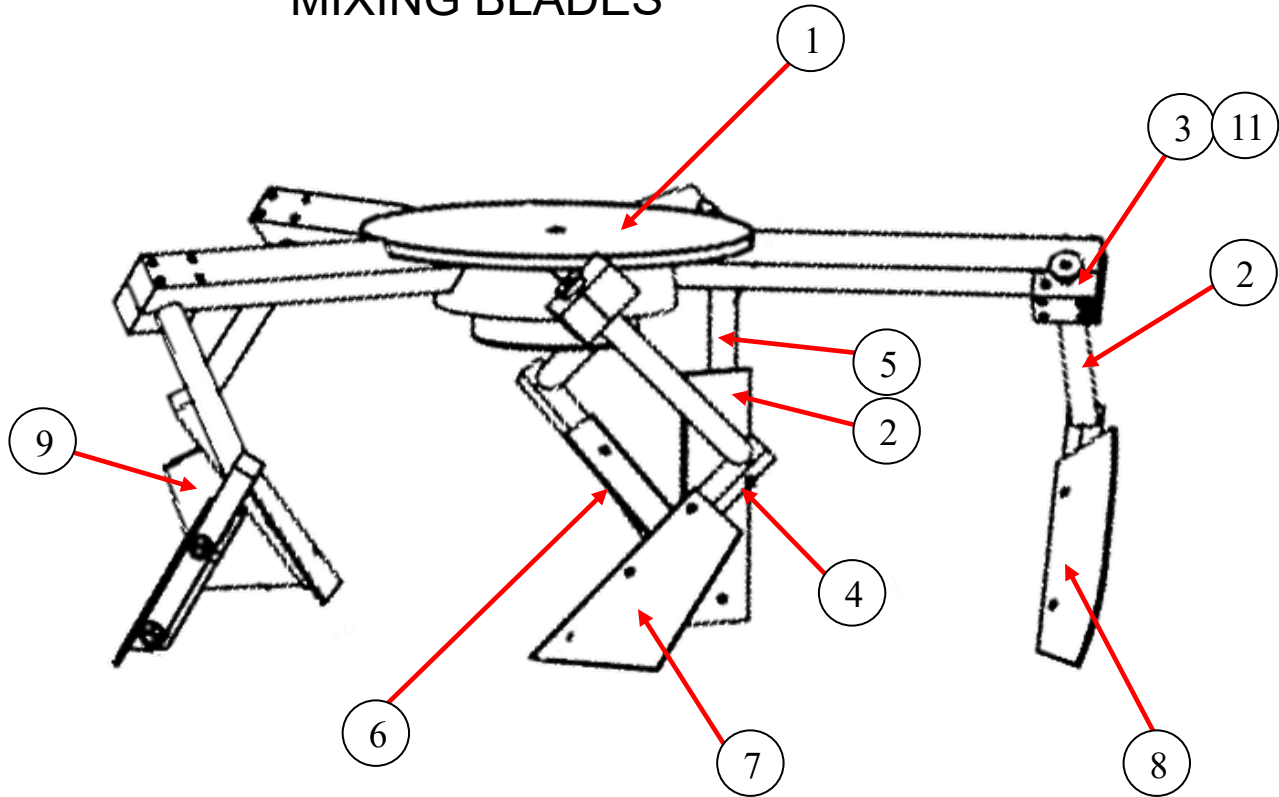

ID #	PART #	PART DESCRIPTION	QUANTITY	
	88917	MIXER BLADE ASSY	REF	
1	88212	WELDMENT	1	EA
2	88214	ARM SHAFT	5	EA
3	88213-A	PADDLE ARM CLAMP	6	EA
4	88231	ARM SQUARE	5	EA
5	88338	SHAFT STRAIT	1	EA
6	88508	MIXER HALF BLADE	3	EA
7	88509	MIXER MAIN BLADE	4	EA
8	88510	MIXER OUTER BLADE	1	EA
9	88511	MIXER INSIDE BLADE	1	EA
10	88197-P	PADDLE	1	EA
11	88981	KEY	5	EA

### BAG BREAKER/SAFTEY GRATE

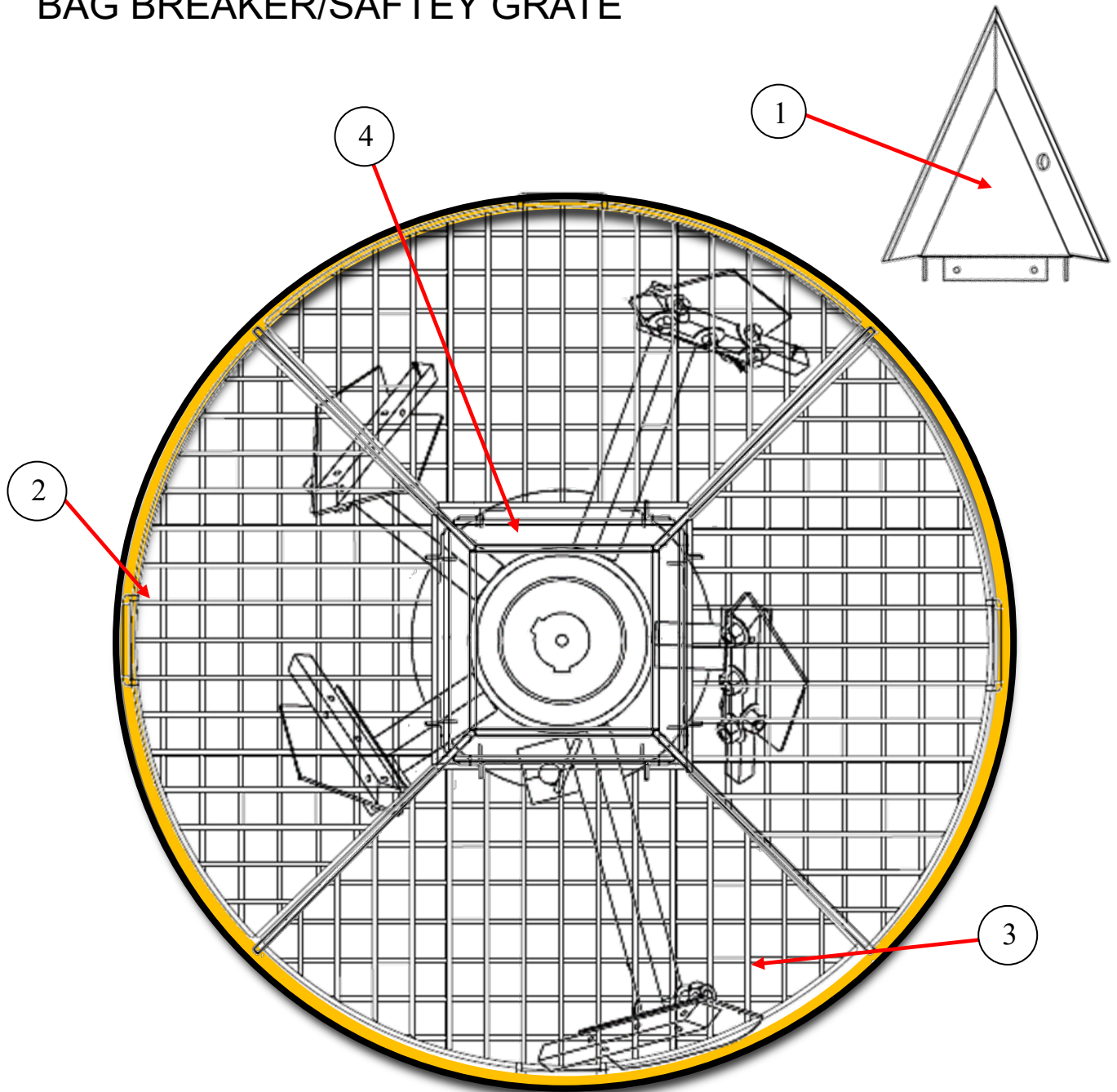

ID #	PART #	PART DESCRIPTION	QUANTITY	
1	88523	PYRAMID BAG CUTTER	1	EA
2	88506	SCREEN DOOR WELDMENT 2.5" OPENING	3	EA
3	88507	SCREEN DOOR WELDMENT 1" OPENING	1	EA
4	88521	FRAME WELDMENT BOTTOM, MIXER SUPPORT	1	EA



## SINGLE DOOR ASSEMBLY

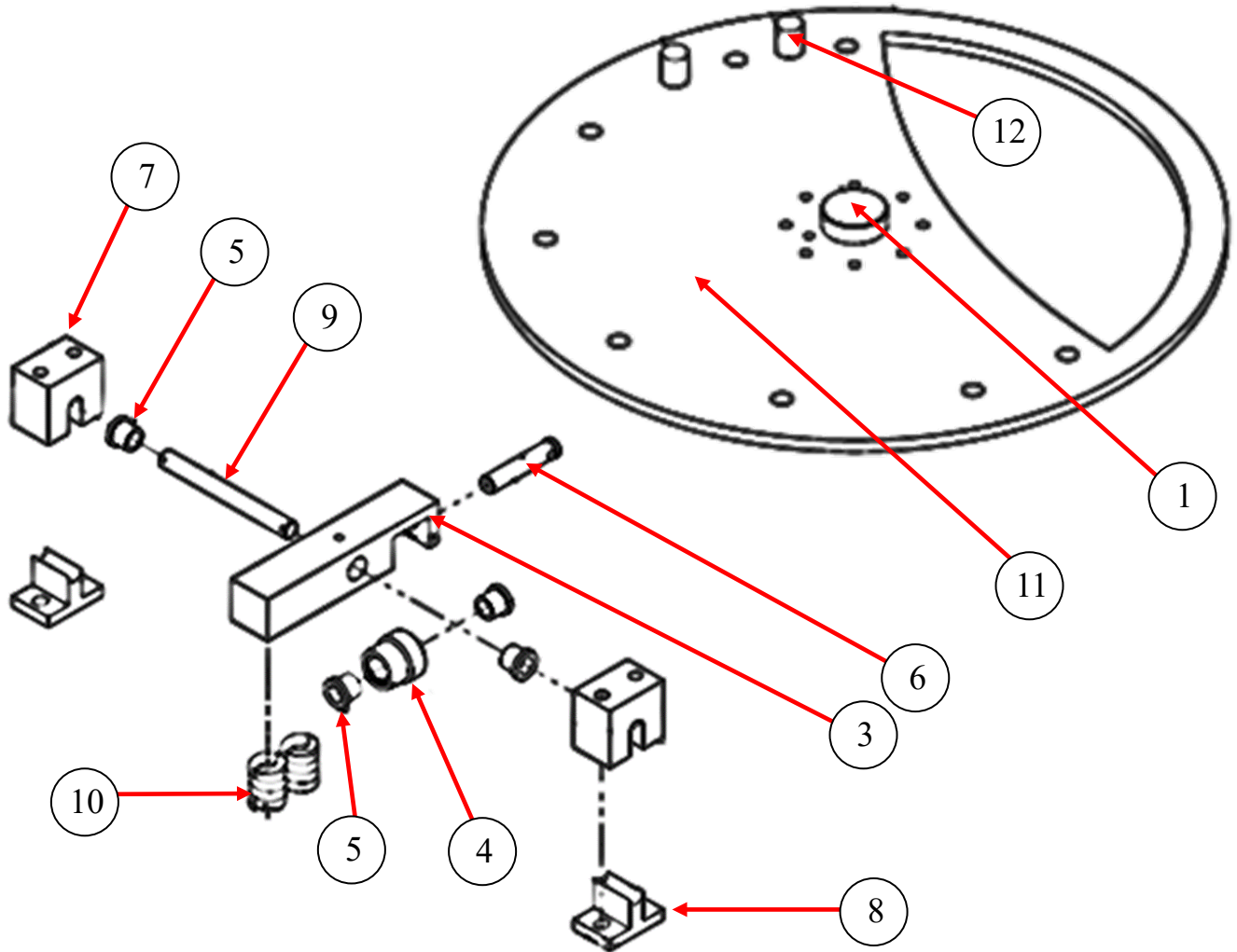

ID #	PART #	PART DESCRIPTION	QUANTITY	
1	88696	DRIVE ADAPTER	1	EA
2	88698	DOOR, HARDENRD PLATE	1	EA
3	88699	ROLLER HOLDER	1	EA
4	88707	ROLLER	1	EA
5	88695	BRONZE FLANGED BEARING	4	EA
6	88712	PIN MACHINED	1	EA
7	88713	BOLT BLOCK FOR ROLLER	2	EA
8	88714	T BLOCK FOR ROLLER BLCOK	2	EA
9	88716	ROLLER PIN	1	EA
10	88711	SPRING	2	EA
11	88697	DOOR OUTER PLATE	1	EA
12	88871	PIN, DOOR ROTATION STOP	2	EA



## MAIN SHAFT ASSEMBLY MOTOR/GEAR BOX

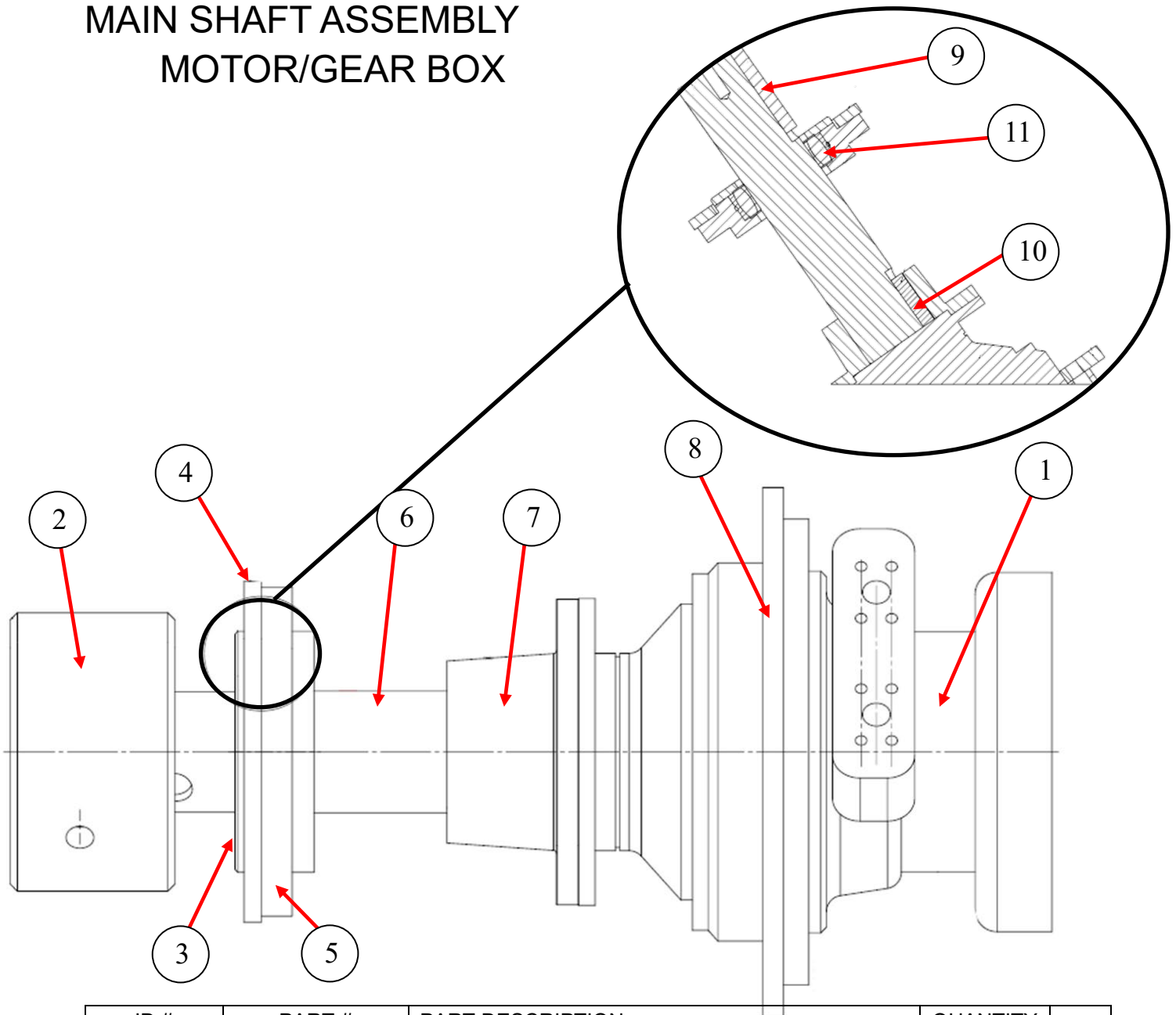

ID #	PART #	PART DESCRIPTION	QUANTITY	
1	88192	HYDRALIC MOTOR	1	EA
2	88200	HUB	1	EA
3	88195	BEARING CAP	1	EA
4	88193	RING	1	EA
5	88194	BEARING RETAINER	1	EA
6	88199	SHAFT	1	EA
7	88198	FLANGE	1	EA
8	88196	FLANGE RING, MOTOR MOUNT	1	EA
9	88232	KEY	2	EA
10	88233	KEY	3	
11	88216	BEARING	1	EA

## MAIN HYDAULIC MANIFOLD

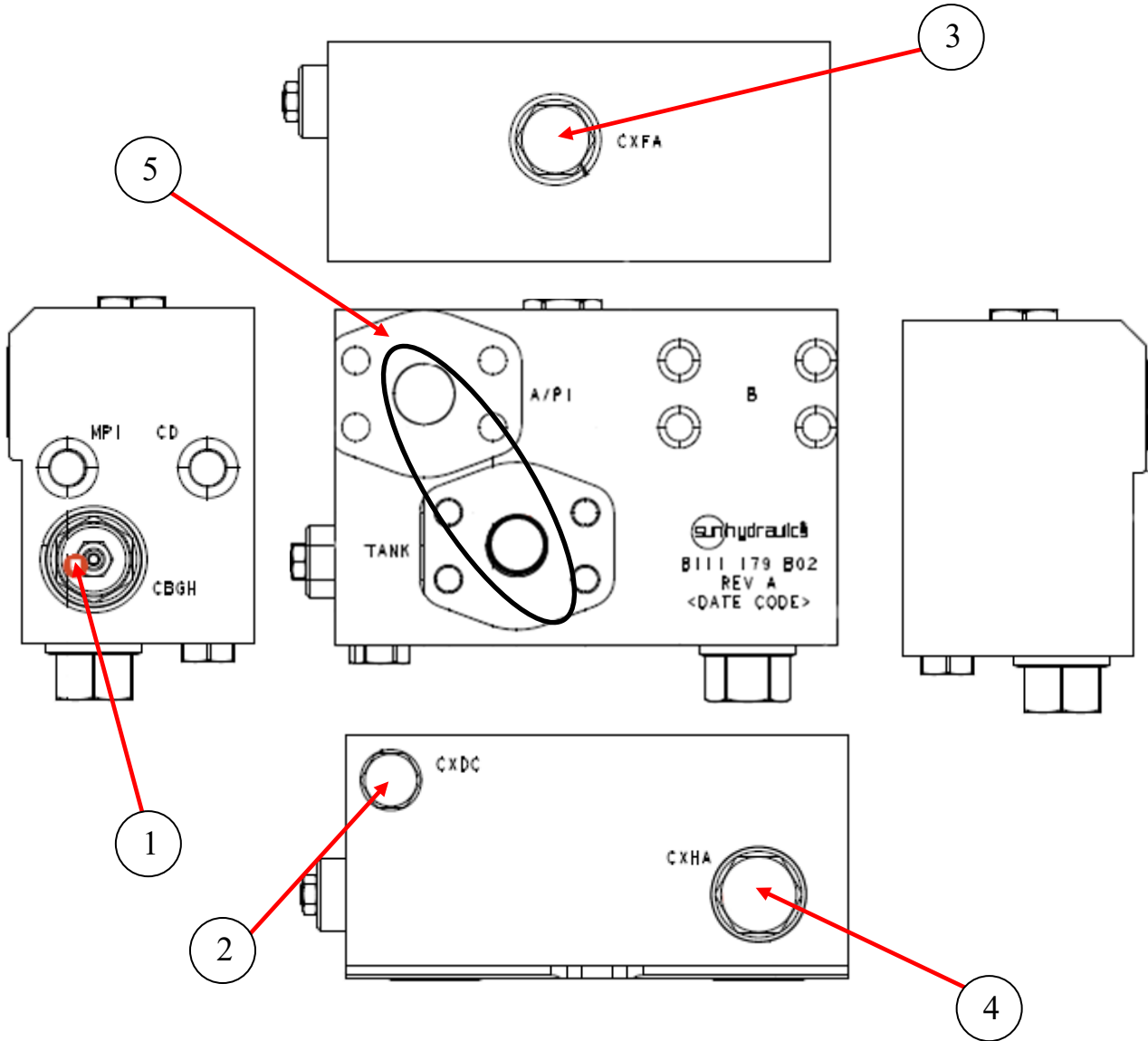

ID #	PART #	PART DESCRIPTION	QUANTITY	
	88602	MANIFOLD ASSY MOTOR DRIVE	REF	
1	CBGH-LDN	COUNTERBALANCE VALVE	1	EA
2	CXDC-XAN	CHECKVALVE	1	EA
3	CXFA-XAN	CHECKCALVE	1	EA
4	CXHA-XAN	CHECKVALVE	1	EA
5	500-001-219	O RING, BUNA-N	2	EA

## MAIN HYDAULIC MANIFOLD SCHEMATIC

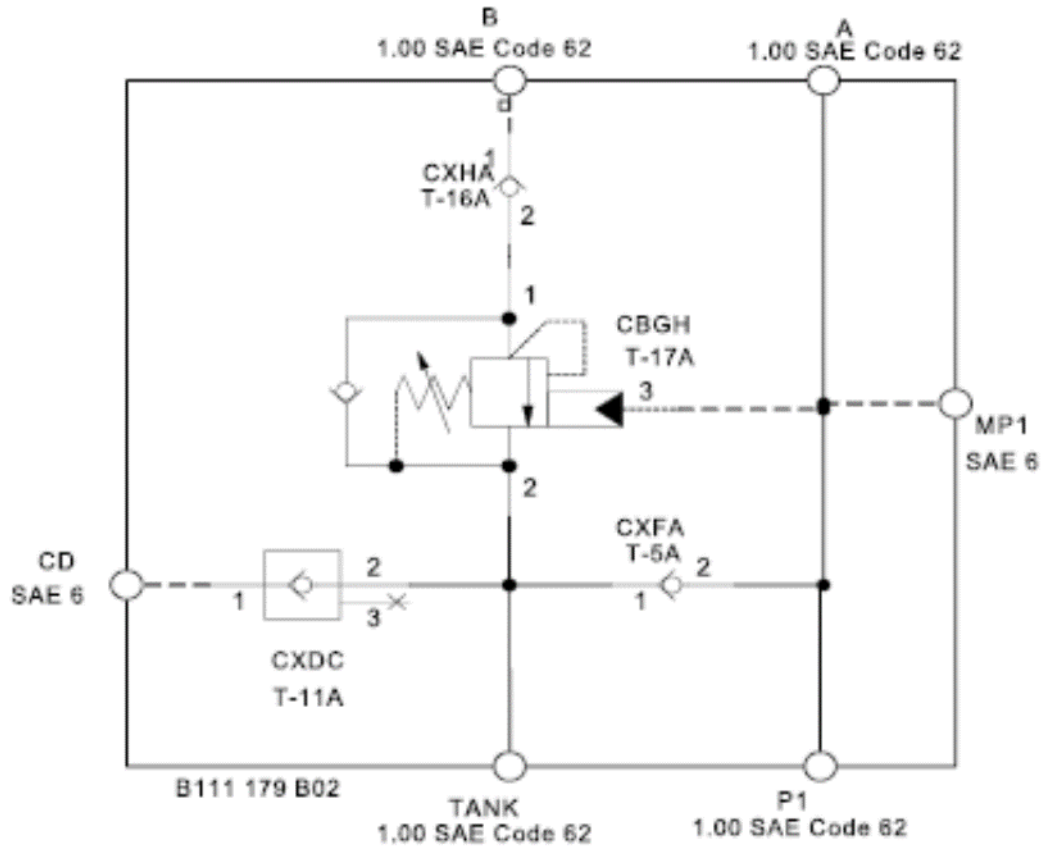

## FRAME ASSEMBLY

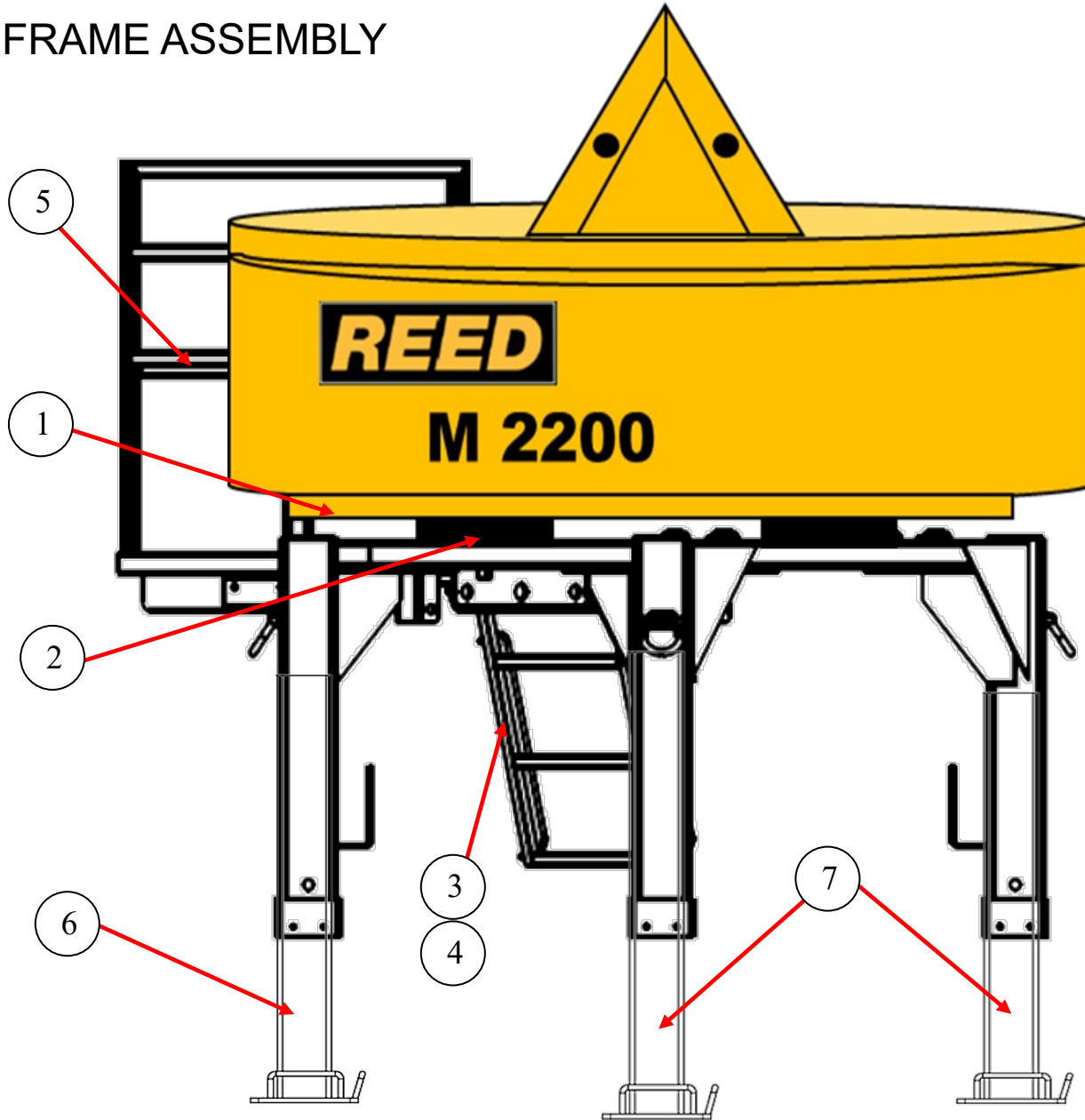

ID #	PART #	PART DESCRIPTION	QUANTITY	
1	88544	FRAME WELDMENT BOTTOM, MIXER SUPPORT	1	EA
2	88209	FRAME WELDMENT, FORKLIFT, PAN MIXER	1	EA
3	88650	STEP WELDMENT REMOVABLE, PAN MIXER	1	EA
4	88975	HANDLE, PAN MIXER	1	EA
5	88731	GUARD FOR WALKING PLATFORM	1	EA
6	88207	INNER LEG WELDMENT LH, PAN MIXER	2	EA
7	88208	INNER LEG WELDMENT RH, PAN MIXER	2	EA
	88719	BRACKET, CONTROL BOX MOUNT WELDMENT	1	EA
	88970	BRACKET WELMENT, REMOTE CABLE	1	EA

### LIFT CYLINDER

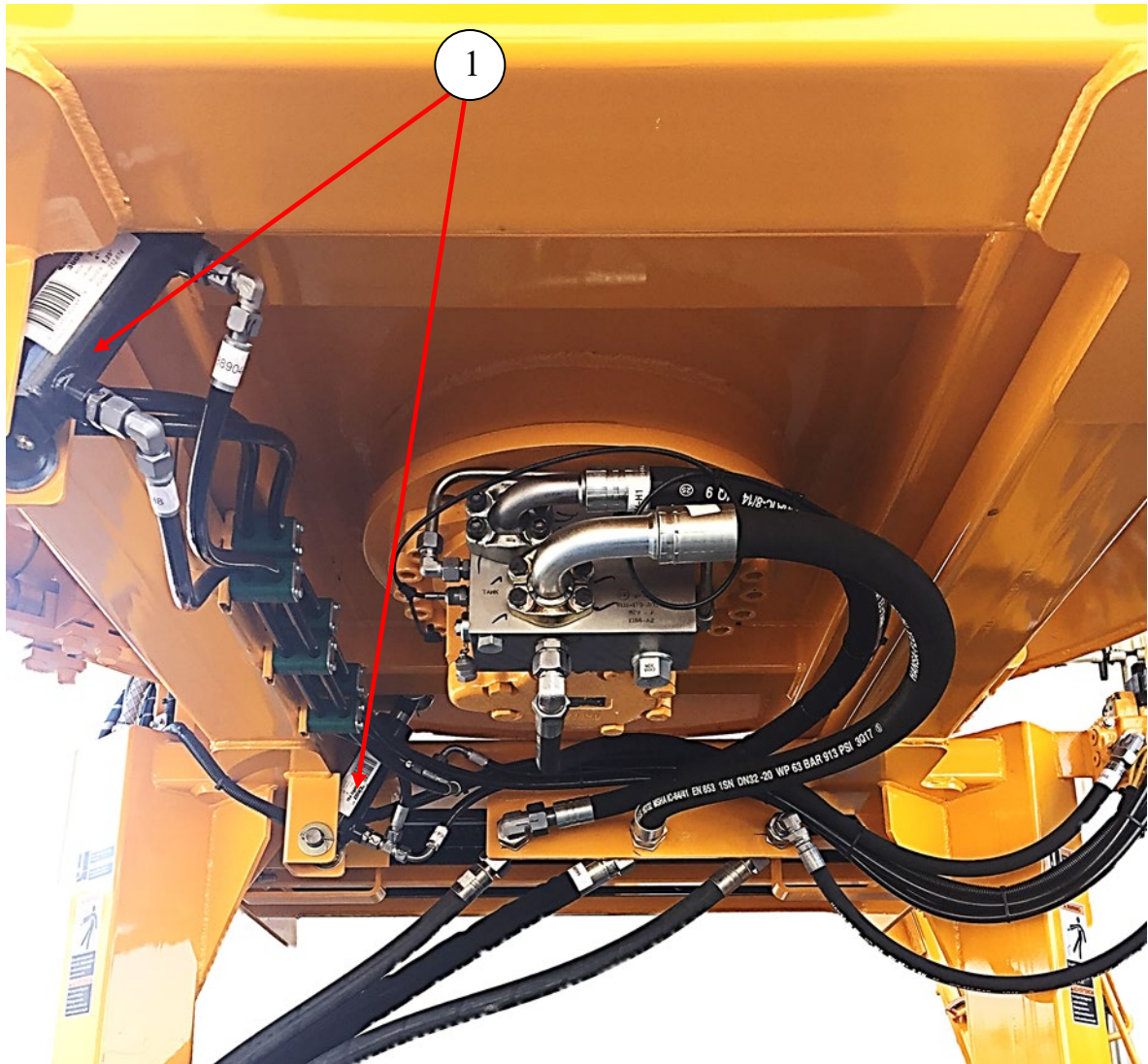

ID #	PART #	PART DESCRIPTION	QUANTITY	
1	88256	CYLINDER HYD, 2" BOR 4" STROKE	2	EA

### HYDRAULIC VALVE

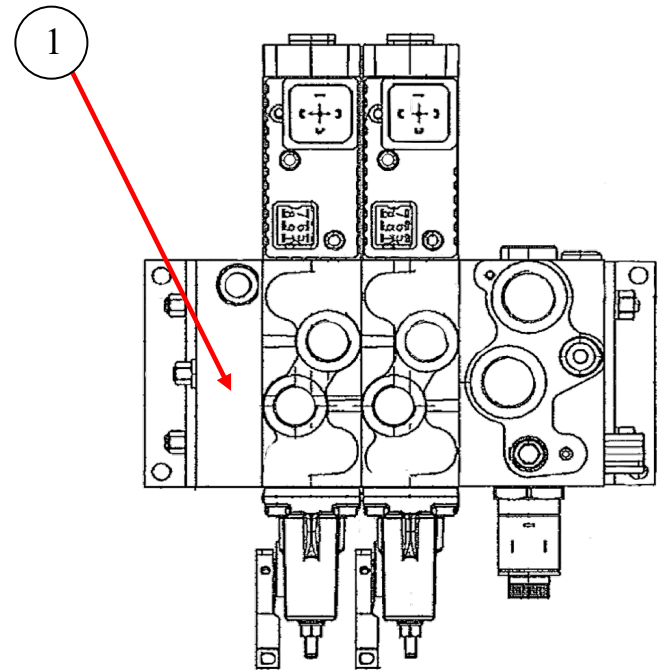
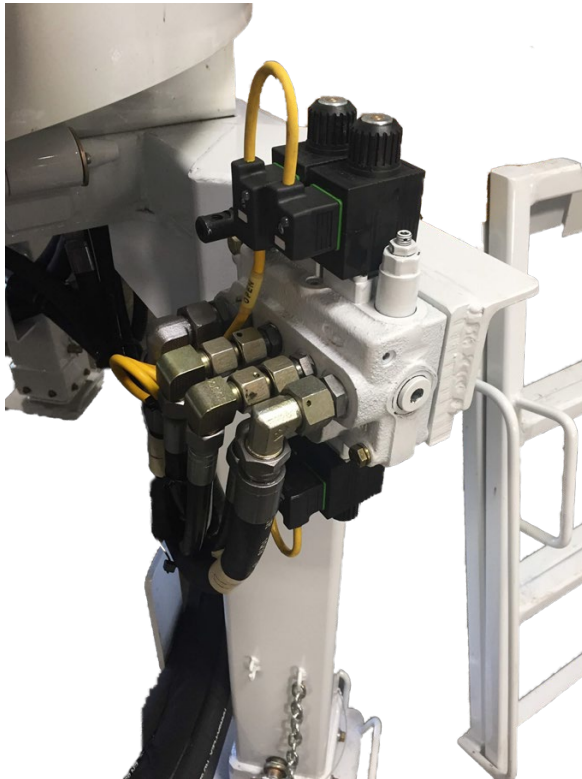

ID #	PART #	PART DESCRIPTION	QUANTITY	
1	89809	VALVE WALVOIL 2 SPOOL W/ ONE FRICTION SEC.	1	

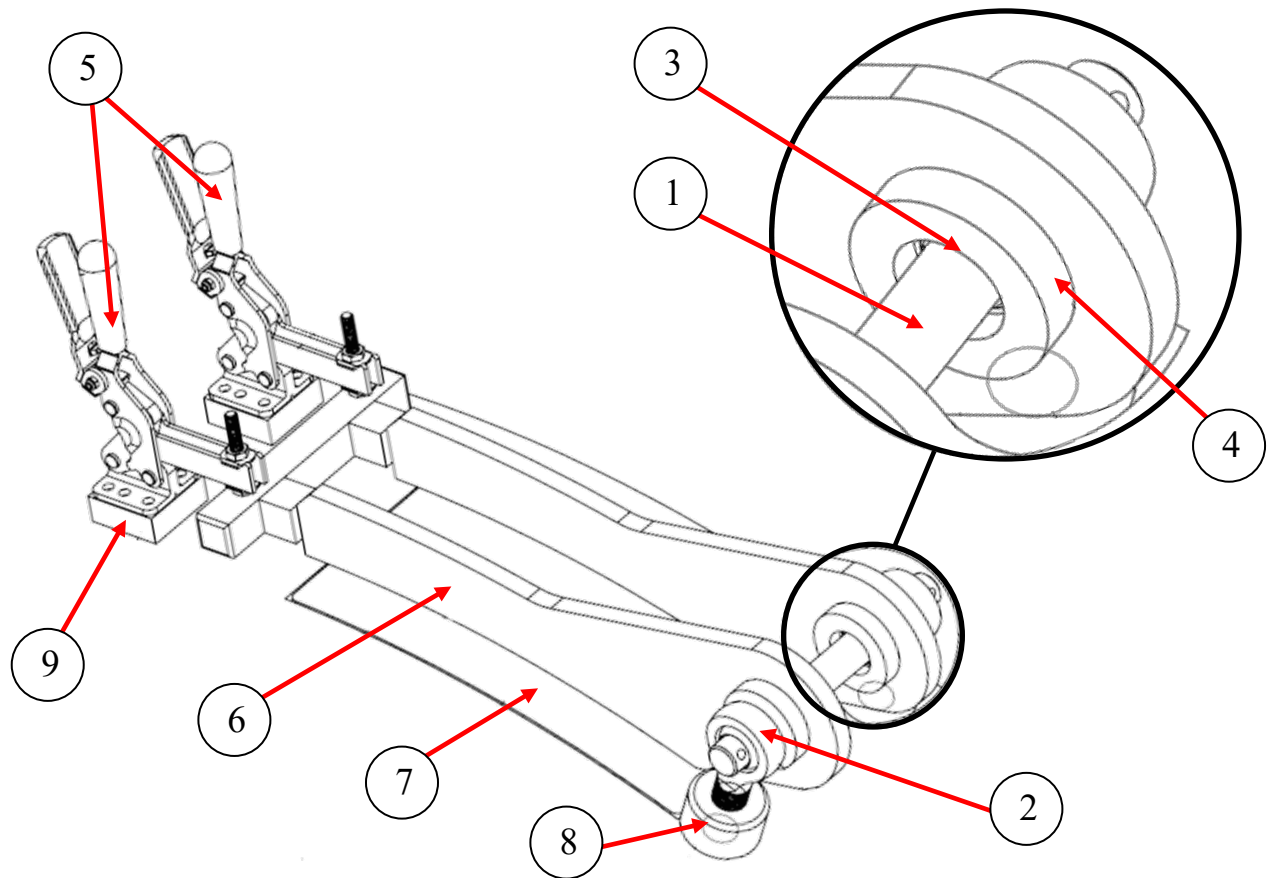

**CLEAN-OUT DOOR ASSEMBLY**

ID #	PART #	PART DESCRIPTION	QUANTITY	
	88900	DOOR CLEAN OUT, ASSY PAN MIXER		
1	88893	BALL JOINT 7/8" SWIVEL BEARING	2	EA
2	88894	BALL JOINT 7/8" ROD END	2	EA
3	88895	SHAFT 7/8" DIA	1	EA
4	88899	RETAINING RING	4	EA
5	88896	CLAMP HOLD DOWN TOGGLE	2	EA
6	88897	GUSSET CLEAN OUTDOOR	2	EA
7		CLEAN OUT DOOR	1	EA
8	88901	SUPPORT, DOOR, HINDGE BEARING	2	EA
9	88902	SUPPORT, DOOR, CLAMP	2	EA

## PANEL WIRING HARNESS

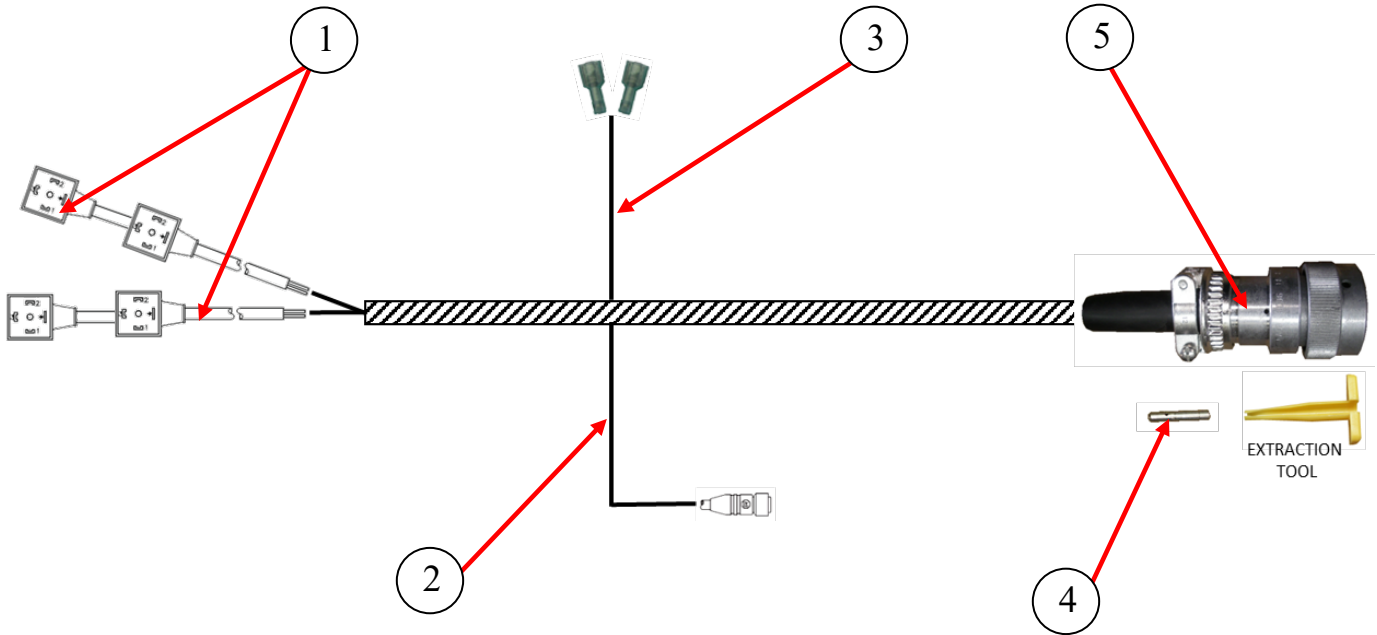

ID #	PART #	PART DESCRIPTION	QUANTITY	
	88733-H	MAIN CONNECTION CABLE	REF	
1	88243	CABLE WITH 2 DIN PLUG,5M	2	EA
2	77990	CABLE, PROXIMITY SWITCH	1	EA
3	85618	CABLE, 16AWG-2C, PVC-GREY	5	EA
4	87457	PIN, FOR 87456 PLUG	16	EA
5	87806-3	PLUG CONNECTOR, 16GA W/CORD GRIP	1	EA
6	77640	DIODE, IN4003	A/R	EA

## MAIN CONNECTION WIRING HARNESS

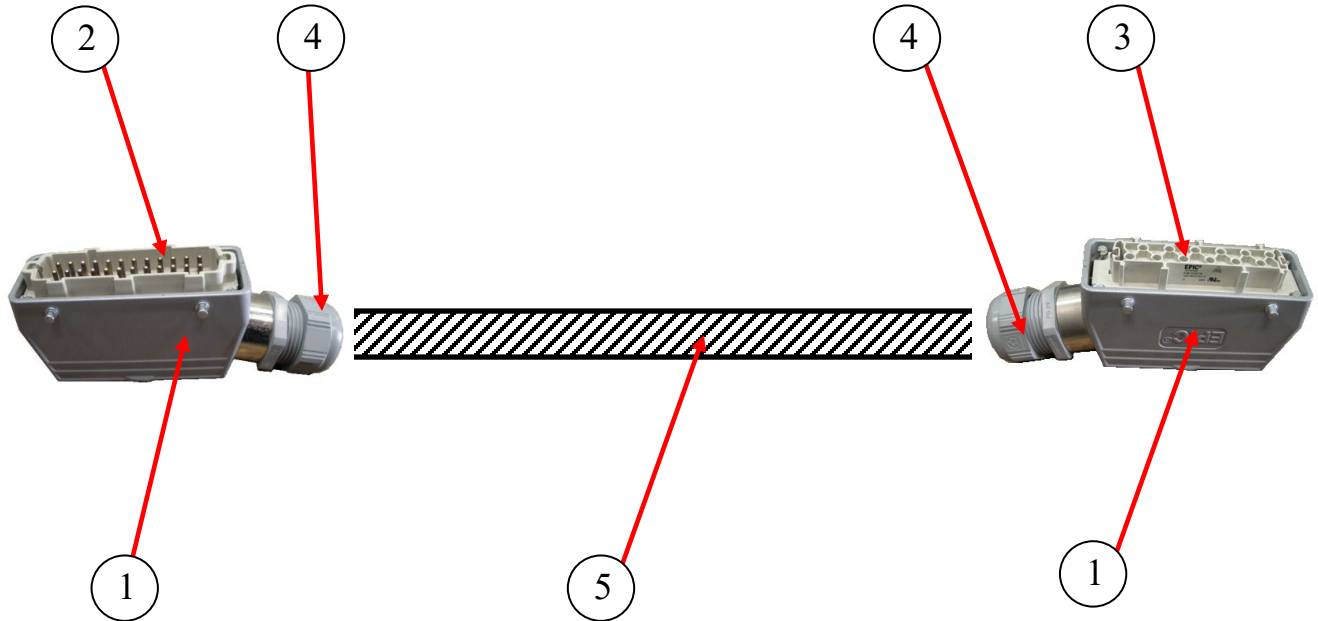

ID #	PART #	PART DESCRIPTION	QUANTITY	
	88610	MAIN CONNECTION CABLE	REF	
1	78698	CONNECTOR HOUSING	2	EA
2	78695	PLUG, 24 PIN (MALE)	1	EA
3	78696	PLUG, 24 PIN (FEMALE)	1	EA
4	801479	CORD GRIP	2	EA
5	2FL-14250	OFLEX 14AWG-25C GRY	25	FT

## MAIN CONTROLS

### CONTROL PANEL

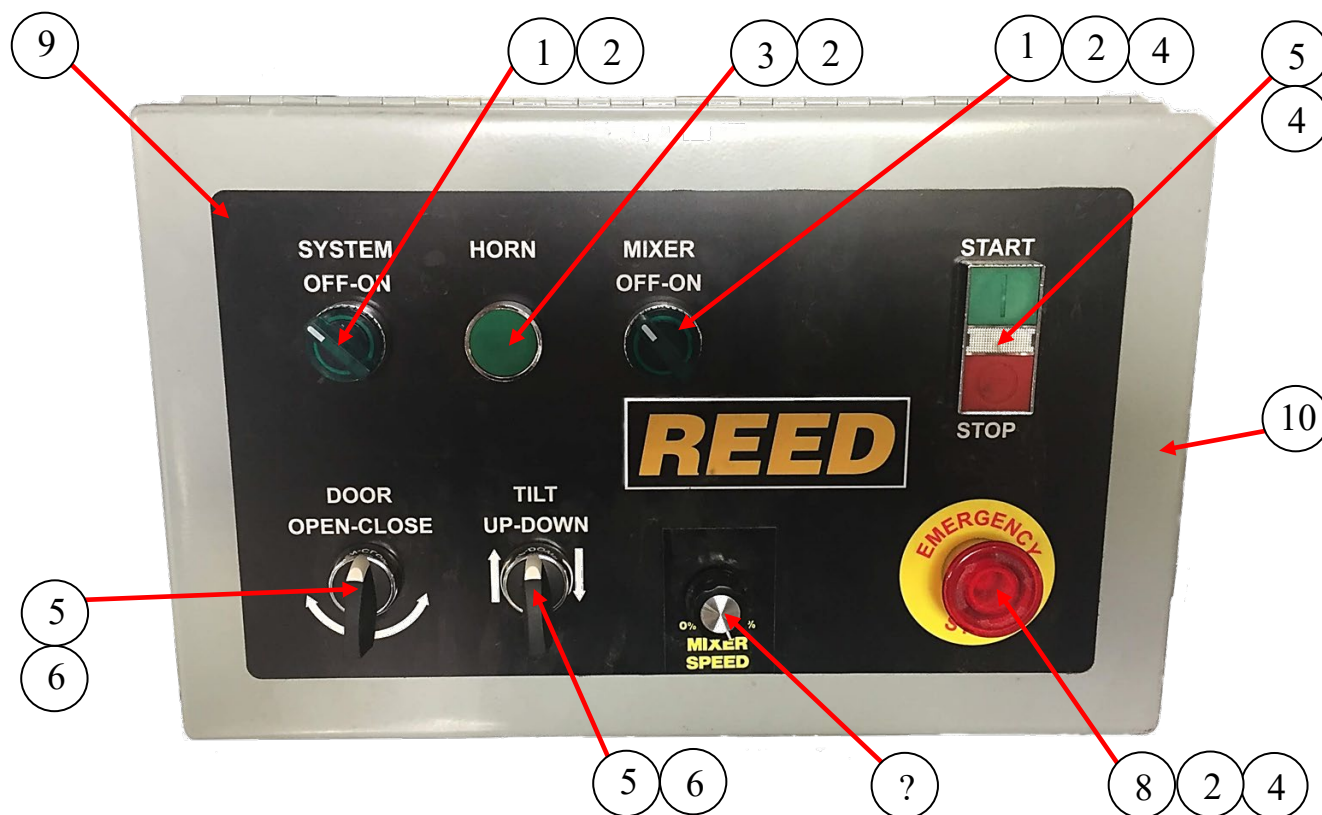

ID #	PART #	PART DESCRIPTION	QUANTITY	
	89733	CONTROL PANEL W/VARIABLE SPEED	REF	
1	88486-1	SELECTOR SW 22MM METAL 2 POS GREEN 120AC	2	EA
2	88486-1C	NO CONTACT BLOCK	7	EA
3	88486-4	PUSHBUTTON GEN, 22MM MOM W/O BLOCK	1	EA
4	88486-2C	NC CONTACT BLOCK	7	EA
5	88623	SELECTOR SWITCH 22MM 3 POS	2	EA
6	88623-1	CONTACT BLOCK KIT W 2NO CONTACT BLOCK	4	EA
7	88486-6	PUSHBUTTON 22MM ON/OFF	1	EA
8	88486-3	PUSHBUTTON RED, 22MM E-STOP	1	EA
9	88877	DECAL, CTRL BOX	1	EA
10	88546	HOFFMAN BOX 16X10X6	1	EA

## FUSE, DIODE, GROUND BLOCK

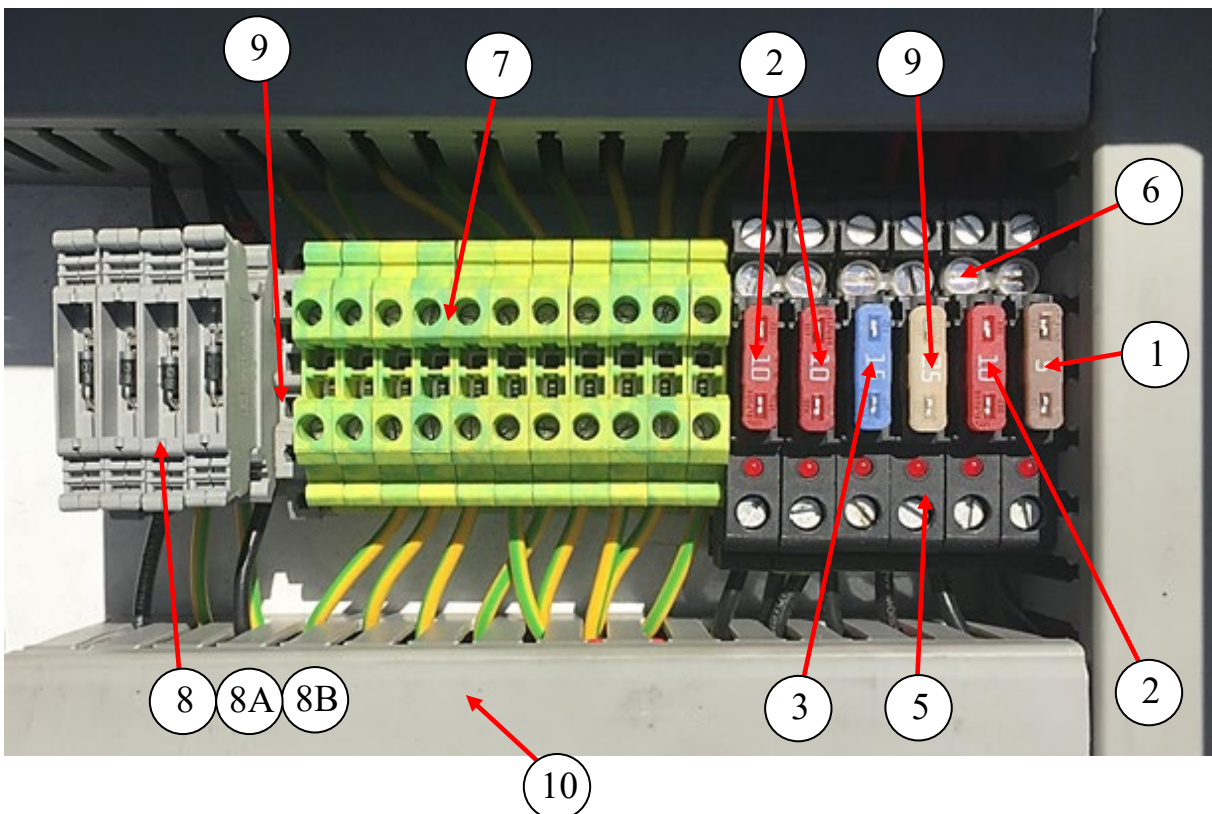

ID #	PART #	PART DESCRIPTION	QUANTITY	
	89733	CONTROL PANEL W/VARIABLE SPEED	REF	
1	90392	FUSE, ATO 5	1	EA
2	800449	FUSE, ATO 10	3	EA
3	90391	FUSE, ATO 15	1	EA
4	800447	FUSE, ATO 25	1	EA
5	88881	FUSE HOLDER LED	6	EA
6	88881-B	JUMPER FIXED BRIDGE	A/R	
7	88534	UNIVERSAL GROUND TERMINAL BLOCK	11	EA
8	88530	FED THRGH MODULE TERMINAL BLOCK W/DIODE	4	EA
8A	W-104185	DIODE WITH TERM BLOCK	4	EA
8B	W-104186	TERM BLOCK FOR DIODE	4	EA
9	88532	END CLAMP DIN RAIL	4	EA
10	88856	WIRE DUCTING 1X2.25 IN. W/COVER	A/R	



### RELAY, TIMER

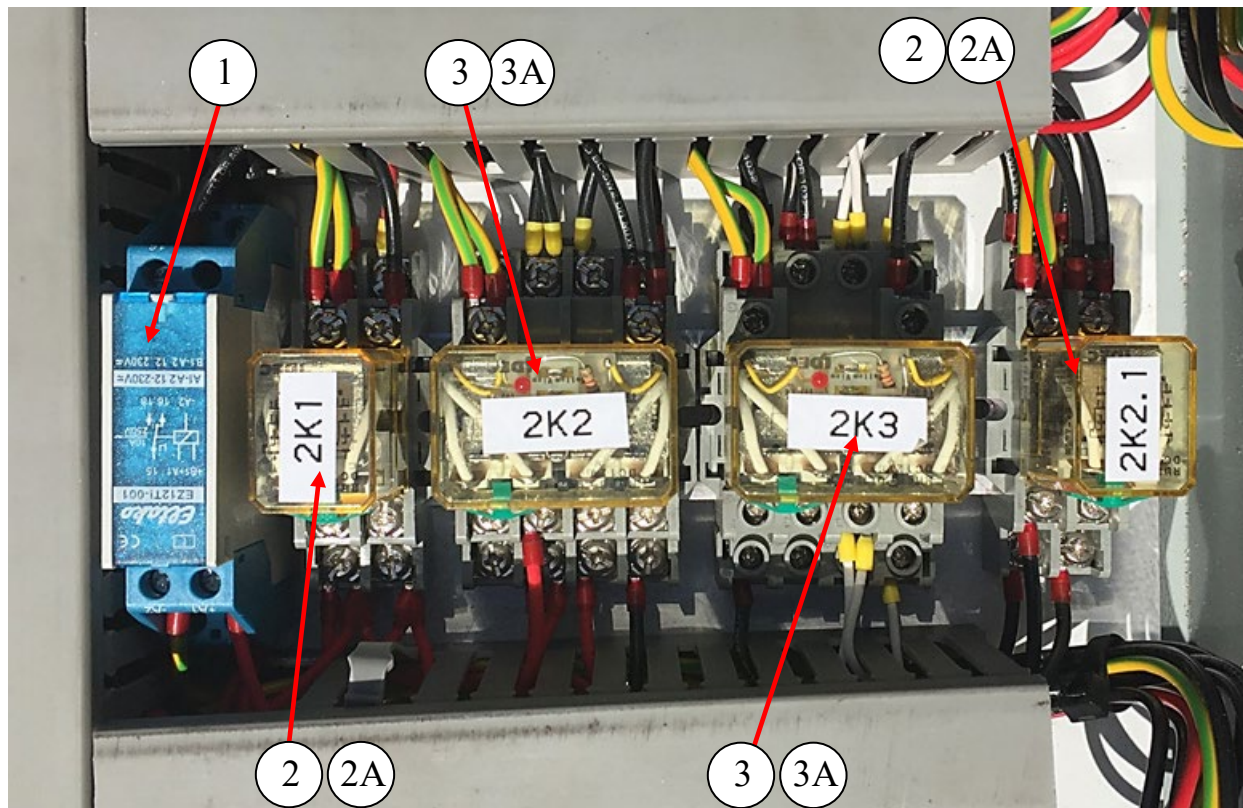

ID #	PART #	PART DESCRIPTION	QUANTITY	
	89733	CONTROL PANEL W/VARIABLE SPEED	REF	
1	W-105331	RELAY-TIMER (2T1)	1	EA
2	88345-1	RELAY, 2PLDT, 12VDC, W/MOMENTARY CHECK BTN	2	EA
2A	88347	RELAY BASE, FOR 88345 (2K1, 2K2.2)	2	EA
3	88527	RELAY, 4PDT POLE CHANGE OVER, 12VDC	2	EA
3A	88527-1	RELAY BASE, 88527	2	EA



## RELAY, TIMER, CONTROLER

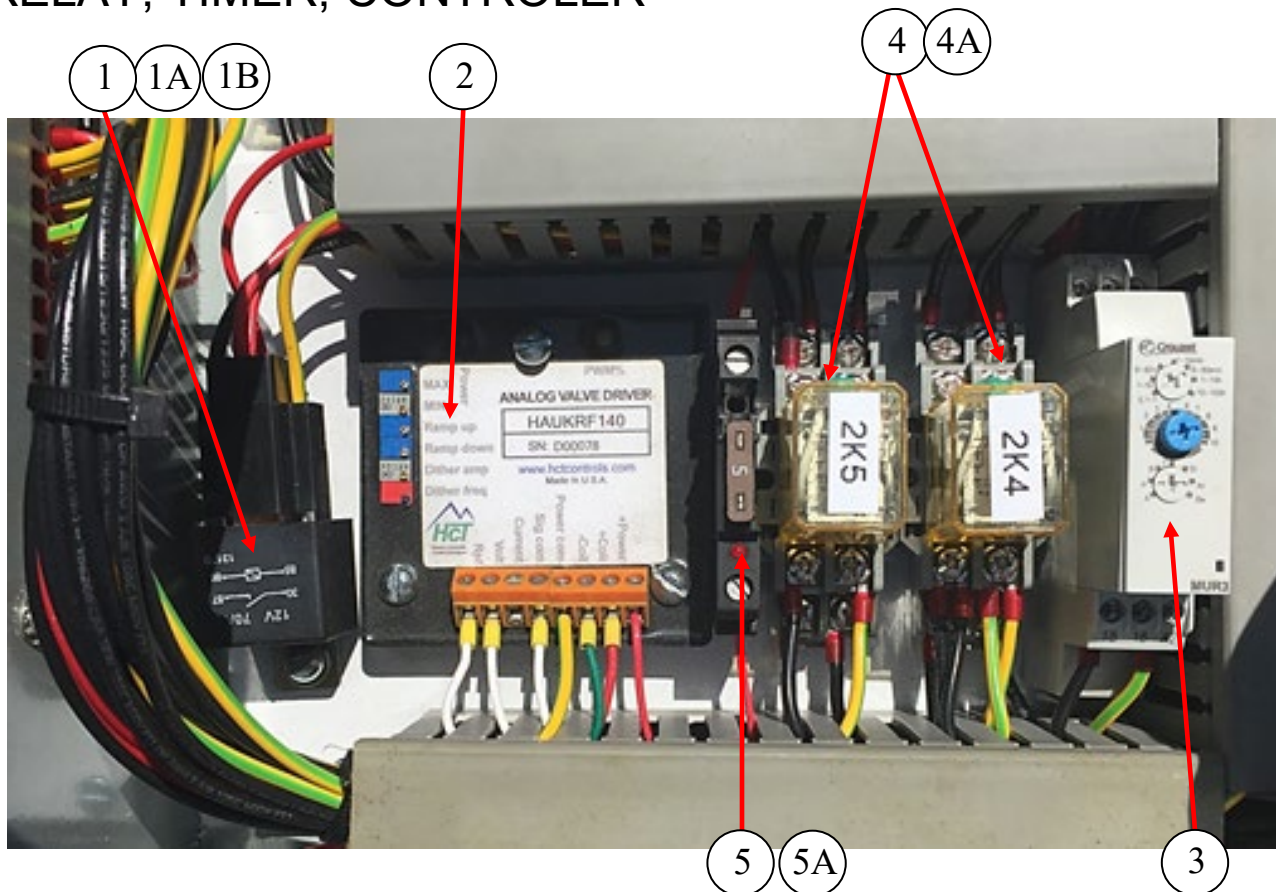

ID #	PART #	PART DESCRIPTION	QUANTITY	
	89733	CONTROL PANEL W/VARIABLE SPEED	REF	
1	W-105617	CONNECTOR, 70A RELAY	2	EA
1A	W-105618	RELAY, SPST, 12V, 70A	1	EA
1B	W-105619	SOCKET, W-105618 RELAY	1	EA
2	89734	SINGLE OUTPUT PROPORTIONAL CONTROLER	1	EA
3	W-106393-1	RELAY, TIMER	1	EA
4	88345-1	RELAY, 2PLDT, 12VDC, W/MOMENTARY CHECK BTN	2	EA
4A	88347	RELAY BASE, FOR 88345 (2K1, 2K2.2)	2	EA
5	88881	FUSE HOLDER LED	1	EA
5A	90392	FUSE, ATO 5	1	EA

## PLUG, CONNECTOR

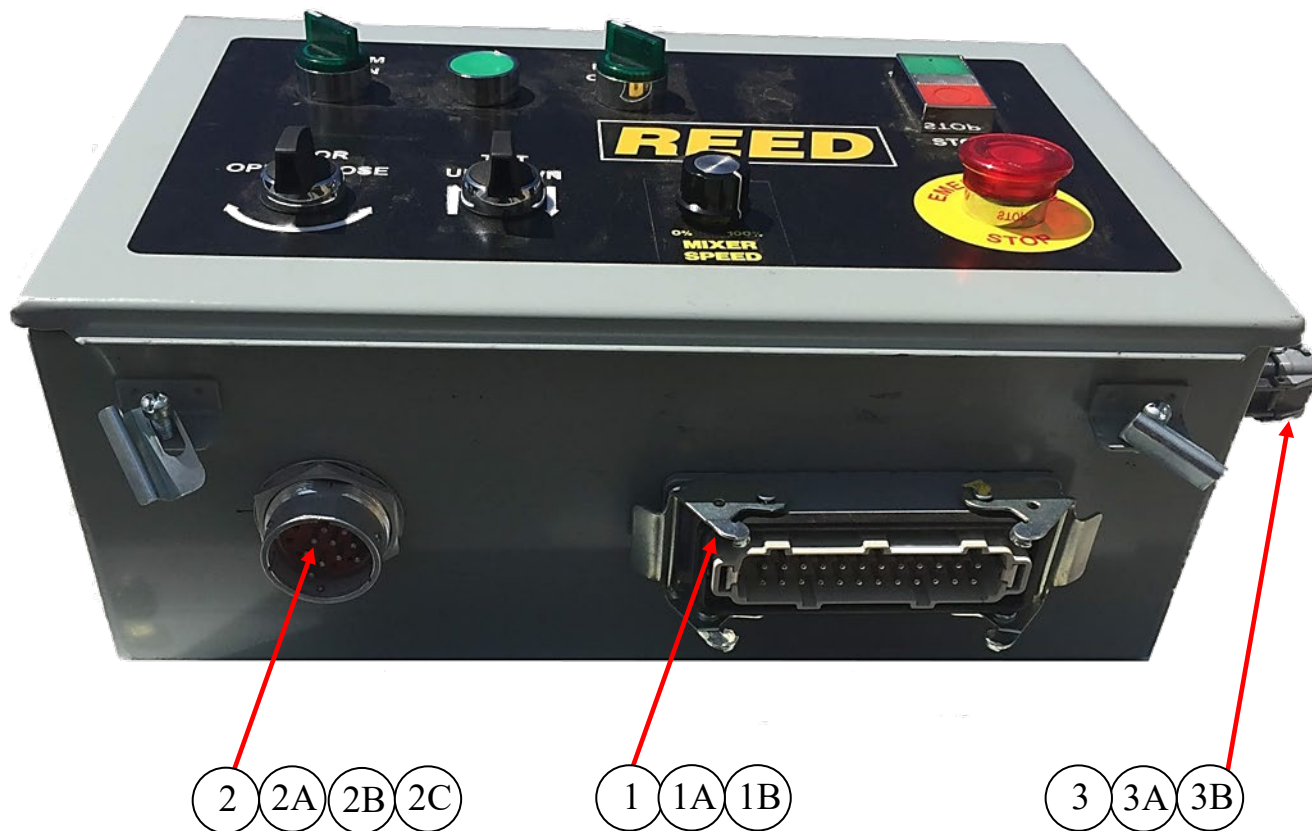

ID #	PART #	PART DESCRIPTION	QUANTITY	
	89733	CONTROL PANEL W/VARIABLE SPEED	REF	
1	78695	CONN. INSERT, 24P MALE, 16A	1	EA
1A	78697	CONN. BASE-LATCH, 24P	1	EA
1B	78697-C	COVER FOR, 78697 CONN BASE	1	EA
2	88478-3	RECEPTACLE, BULKHEAD 16 PIN	1	EA
2A	88479-1	NUT FOR 88478-2	1	EA
2B	88480-1	WASHER FOR 8847-2	1	EA
2C	87807	PIN MALE, FOR 87806 PLUG	16	EA
3	89741	PANEL MOUNT BASE 4 PIN	1	EA
3A	89742	GASKET FOR 89741	1	EA
3B	89743	PLUG, MALE 10A, 4 PIN	1	EA

AVAILABLE OPTIONS

WATER TANK ASSEMBLY



VARIABLE SPEED MIXER CONTROL

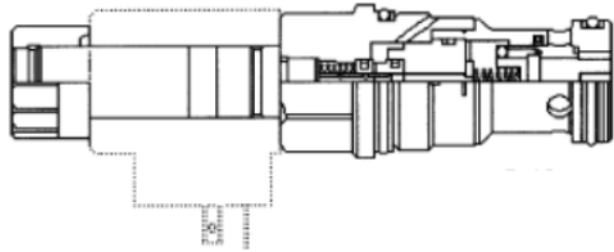



LINE PUMP

# SAFETY MANUAL 7

VERSION 7.0.1

A guide for the prevention of accidents when driving, operating, cleaning, and maintaining small line concrete pumps and related equipment.



AMERICAN CONCRETE PUMPING ASSOCIATION  
606 Enterprise Drive | Lewis Center, OH 43035  
P: 614.431.5618 | F: 614.431.6944  
[WWW.CONCRETEPUMPERS.COM](http://WWW.CONCRETEPUMPERS.COM)



**CALIFORNIA**

**Proposition 65 Warning**

**Diesel engine exhaust and some of its constituents are known to the State of California to cause cancer, birth defects, and other reproductive harm.**

## SAFETY MANUAL

### A GUIDE FOR THE PREVENTION OF ACCIDENTS WHEN DRIVING, OPERATING, CLEANING, AND MAINTAINING CONCRETE LINE PUMPS AND RELATED EQUIPMENT

#### Introduction

Safety is one of the major concerns of every person involved in the concrete pumping industry. Although much of the responsibility for everyday safety rests upon the pump operator, it is vital that everyone involved makes safety the top priority. This includes the owners, the mechanics, the ready mix drivers, the placing crew, the concrete contractors, and the machine manufacturers.

Although this *Safety Manual* covers a great deal of information regarding the prevention of accidents while operating a concrete pump, it is unlikely that every conceivable circumstance has been covered. Regardless of how thorough a manual like this may be, there is always the unexpected. Please understand that there is no substitute for **common sense** and dedication to the idea that **you are responsible for your own safety**, and affect the safety of those around you. You have to know the rules first, but you

must keep your mind on the job if knowledge of the rules is going to keep you and your coworkers alive and well. No attempt has been made in this *Safety Manual* to provide the highly specialized knowledge of the workings of the individual machines that is also critical for safe and proper operation. For that, you must **read and understand the operation manual for the machine(s) that you operate!**

This *Safety Manual* is a guide for the prevention of accidents and is to be used in conjunction with **professional training**. The ACPA now has an Operator Training Program. Additional information and materials are available through the American Concrete Pumping Association, including, specifically, an Operator Certification Program. Make the commitment to be professional - get your certification!

Version 7.0.1

February 2015

© Copyright 1992, 1993, 1999, 2000, 2003, 2006, 2008, 2015

CPMA, All rights reserved.



# SAFETY MANUAL

## Table of Contents

Introduction . . . . .	iii
General Rules . . . . .	1
I.    Before You Leave The Yard . . . . .	2
1.    Safety Alert Symbol And Signal Word Explanation . . . . .	2
2.    What To Do Before You Arrive At Work . . . . .	2
3.    What To Check Before You Leave The Yard . . . . .	4
4.    Safety Rules For Towing Trailer-Mounted Concrete Pumps . . . . .	8
II.   On The Job Site - Safety Rules For Job Setup . . . . .	9
5.    Setting Up A Trailer-Mounted Pump and/or A Separate Pipeline . . . . .	9
III.  Concrete Pump Operation . . . . .	14
6.    Safety Rules For Pump Operators. . . . .	14
7.    Safety Rules For Shotcreting . . . . .	22
IV.  Cleaning The Pump And System . . . . .	24
8.    Safety Rules For Cleaning The Concrete Valve And Hopper . . . . .	24
9.    Safety Rules For Cleaning The Water Box . . . . .	24
10.   Safety Rules For Cleaning A Separately Laid Pipeline. . . . .	25
V.   Maintenance Of The Machinery . . . . .	31
11.   Safety Rules Regarding Inspection . . . . .	31
12.   Safety Rules Regarding Scheduled Maintenance . . . . .	32
13.   Safety Rules When Servicing The Machinery . . . . .	33
VI.  Coworker Safety . . . . .	35
14.   Safety Rules For Workers Assigned To The Pump. . . . .	35
15.   Safety Rules For The Placing Crew. . . . .	41
Appendix. . . . .	45
VII.  Weld-On Ends/Coupling Comparison . . . . .	46
VIII.  Minimum Pipe Wall Thickness Chart . . . . .	47
IX.  Glossary Of Terms . . . . .	48
X.   Recommended ACPA Hand Signals . . . . .	53
XI.  Bibliography . . . . .	53
Alphabetical Index. . . . .	55

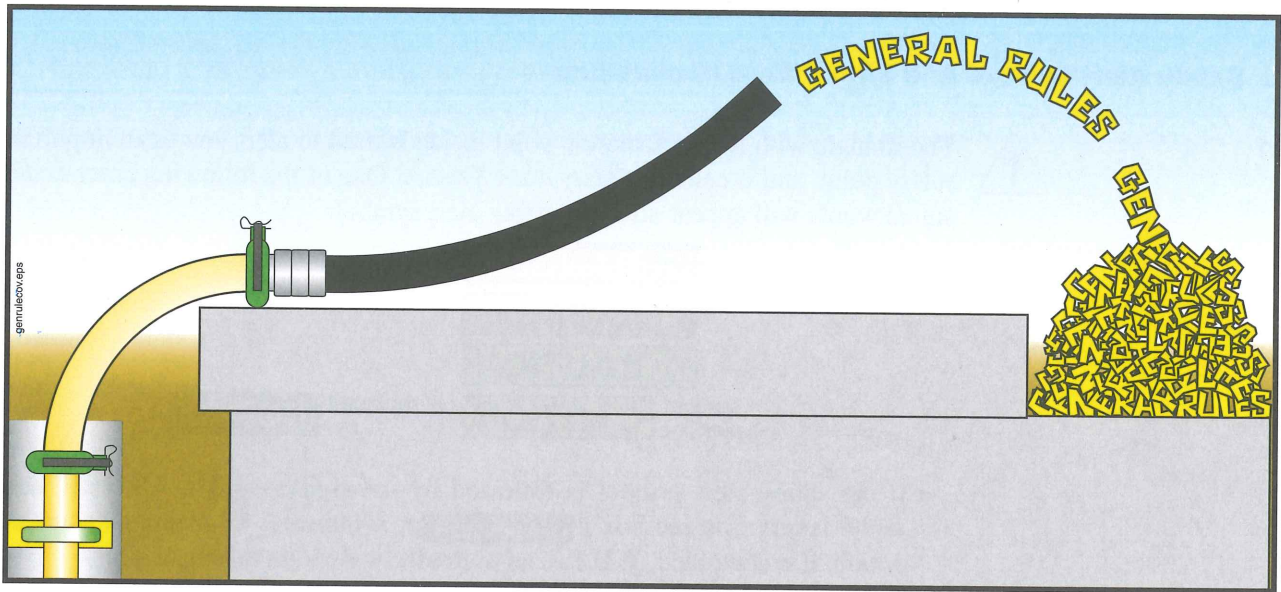

## General Rules Table of Contents

<b>Before You Leave The Yard</b> . . . . .	<b>2</b>
1. Safety Alert Symbol And Signal Word Explanation . . . . .	2
2. What To Do Before You Arrive At Work . . . . .	2
3. What To Check Before You Leave The Yard . . . . .	4
4. Safety Rules For Towing Trailer-Mounted Concrete Pumps . . . . .	8
<b>On The Job Site - Safety Rules For Job Setup</b> . . . . .	<b>9</b>
5. Setting Up A Trailer-Mounted Pump and/or A Separate Pipeline . . . . .	9
<b>Concrete Pump Operation</b> . . . . .	<b>14</b>
6. Safety Rules For Pump Operators . . . . .	14
7. Safety Rules For Shotcreting . . . . .	22
<b>Cleaning The Pump And System</b> . . . . .	<b>24</b>
8. Safety Rules For Cleaning The Concrete Valve And Hopper . . . . .	24
9. Safety Rules For Cleaning The Water Box . . . . .	24
10. Safety Rules For Cleaning A Separately Laid Pipeline . . . . .	25
<b>Maintenance Of The Machinery</b> . . . . .	<b>31</b>
11. Safety Rules Regarding Inspection . . . . .	31
12. Safety Rules Regarding Scheduled Maintenance . . . . .	32
13. Safety Rules When Servicing The Machinery . . . . .	33
<b>Coworker Safety</b> . . . . .	<b>35</b>
14. Safety Rules For Workers Assigned To The Pump . . . . .	35
15. Safety Rules For The Placing Crew . . . . .	41

## I. Before You Leave The Yard

### 1. Safety Alert Symbol And Signal Word Explanation





1.1



The triangle with the exclamation point inside is used to alert you to an important safety point, and is called a *Safety Alert Symbol*. One of the following color-coded signal words will appear after the safety alert symbol:

or - without  
the symbol:

is replaced  
by:

- If the safety alert symbol is followed by the signal word **DANGER** with white letters in a red box (  ), it indicates a hazardous situation which, if not avoided, **WILL** lead to **death or serious injury**.
- If the safety alert symbol is followed by the signal word **WARNING** with black letters in an orange box (  ), it indicates a potentially hazardous situation which, if not avoided, **COULD** result in **death or serious injury**.
- If the safety alert symbol is followed by the signal word **CAUTION** with black letters in a yellow box (  ), it indicates a potentially hazardous situation which, if not avoided, **COULD** result in **minor to moderate injury**.
- The signal word **CAUTION**, used in a yellow box, but **without the safety alert symbol** (  ), means the point addresses a hazard which, if not avoided, **COULD** cause **damage to equipment or property**.
- The signal word **NOTICE** (  ), now replaces the signal word caution (without the safety alert symbol), above.

### 2. What To Do Before You Arrive At Work

2.1

Get enough sleep to be ready for the day's work. Accidents can happen when the body is on the job, but the mind is not.

2.2

Dress in appropriate apparel and Personal Protective Equipment (P.P.E. or just PPE.) See Figure1. You should always wear these items when pumping concrete:

- hard hat;
- safety glasses or goggles (plus a full face shield, when shotcreting);
- snug-fitting clothes;
- gloves;
- steel-toed shoes;

In addition, you should wear:

- hearing protection if you stand near the pump or any other source of noise;



- breathing mask whenever there is cement dust in the air;
- rubber gloves during cleanout or if you'll be touching wet concrete;
- rubber boots anytime you have to stand in concrete;
- full face-shield when shotcreting, or any time material is rebounding.

\* Full face shield should be used in addition to safety glasses when shotcreting, or any time material is rebounding.

\*\* Breathing mask needed when cement dust (or other toxic dust) is present in the air.

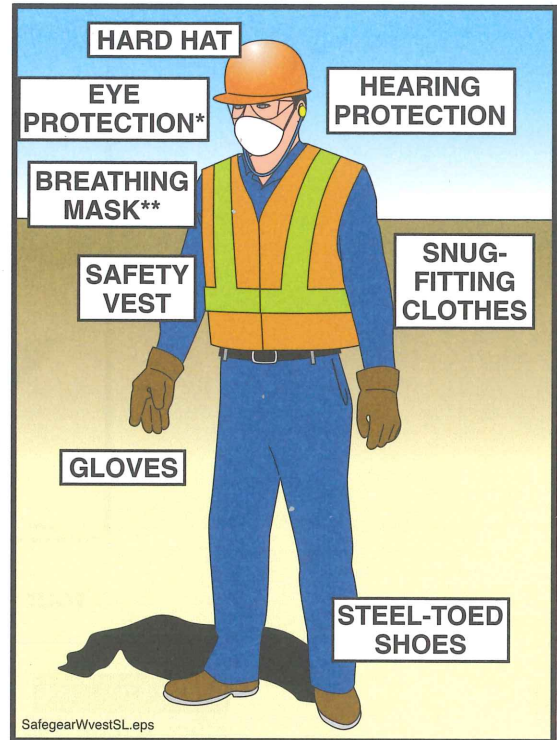

**Figure 1**  
**Personal Protective Equipment (PPE)**

2.3 Jewelry, athletic shoes, sandals, and shorts are examples of clothing that should NOT be worn when pumping.

2.4 **⚠ WARNING** Be sure that any clothing you wear does not have strings, fringes, or other external tightening means that could be caught in moving parts (Figure 2).

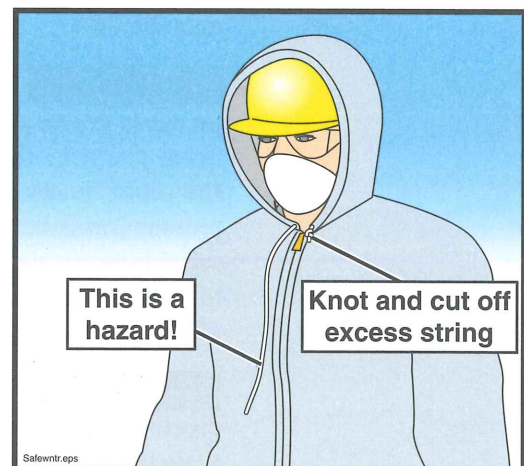
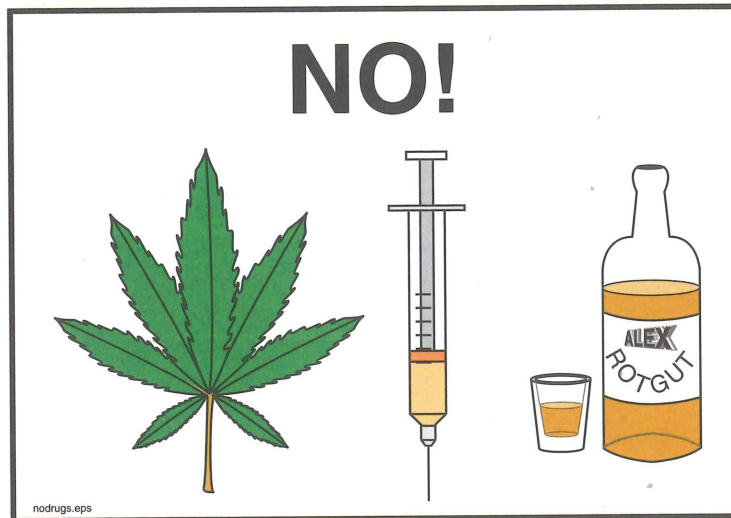

**Figure 2**  
**No strings attached**

# SAFETY MANUAL

2.5 Arrive to work on time. Accidents can be caused by hurrying through procedures.

2.6 **⚠ WARNING** Never go to work on a construction site or work on, around or near a piece of machinery when under the influence of drugs or alcohol. Beware of prescription medications or over the counter drugs, many of which have specific warnings about operating machinery after taking the medication (Figure 3).



**Figure 3**  
Your coworkers depend upon you for their safety

2.7 **⚠ WARNING** Don't bring your personal problems to work with you. In an office setting this may be annoying to coworkers, but on a construction site it can be deadly. The workers around you depend on you for their safety.

### 3. What To Check Before You Leave The Yard

3.1 **⚠ WARNING** Do not operate the machine until you read and understand the unit's operation manual. Lack of understanding of proper operating procedures could result in unsafe operation. Operation manuals are issued with each new unit. If you haven't seen it, ask your supervisor. Replacements are available from the manufacturer.

3.2 **⚠ WARNING** Inspect delivery pipes, concrete delivery hoses, and end hoses for wear. Never use a hose or pipe that is dented or worn out. **Know the maximum pressure that your machine can exert on the concrete, and be sure that the pipes, hoses and clamps are capable of handling the pressure.** Maximum pressure on concrete is stated in operation manuals, service manuals, and on the serial number plate of the machine. A chart showing the minimum wall thickness of pipeline versus maximum pressure is found on page 47 in the Appendix section of this *Safety Manual*.

3.3 **⚠ WARNING** If you will need to use compressed air to clean out the system pipeline, **BE SURE** that you have the proper training, equipment, and attachments to do this procedure safely! Proper attachments include:

- A blowout head with properly sized air discharge regulator valve and separate water/air inlet. The two openings should be spaced apart far enough that a blowout ball could not cover both openings at once.
- A *go-devil*, or a hard sponge ball. Regardless of which is used, it **must** fit into the pipeline tight enough that air cannot escape ahead of it.
- A ball or go-devil catcher that will catch the go-devil or ball when the line has been purged of all concrete, unless another method of controlling the outlet is used. There are two types of catchers (see paragraph 5.24 on page 13).
- A hose that is rated for the pressure of the air compressor you will use and that is able to connect with both the air compressor and the blowout head. The hose must be in good working condition and must be free of cracks, frays, tears or other damage. Do **NOT** improvise on this. **Make sure** you have the right part (Figure 4).

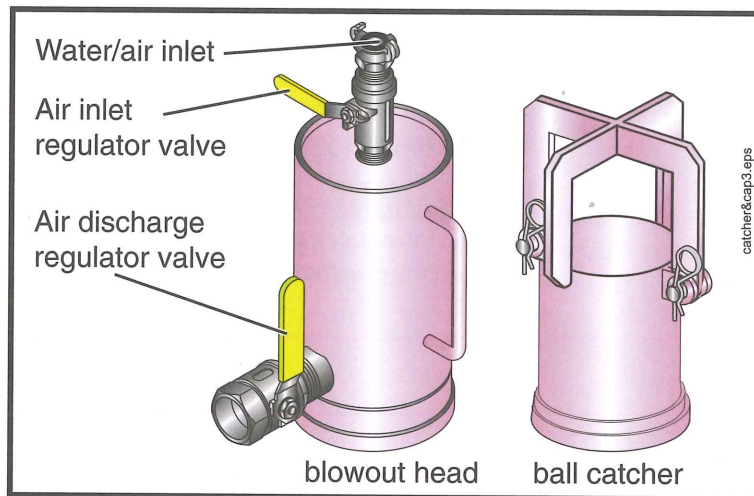

**Figure 4**  
**Compressed air accessories**

- 3.4 **⚠ WARNING** Be sure that the unit is equipped with all the pipes, clamps, gaskets and hoses, blowout adapters, ball catchers, and other accessories that you will need for the day's work. Making do with inappropriate equipment could cause accidents.
- 3.5 On trailer-mounted units, check the oil and cooling system of the pump drive engine. Accidents could occur when lack of maintenance is causing a distraction while operating the equipment.
- 3.6 Be sure the battery has enough charge to start the pump drive engine. You will be rushed on the job if you have to do repair work before you can begin operation.
- 3.7 **⚠ WARNING** The operator is responsible for checking to see that the concrete pump, and delivery system are in safe and proper working condition. If an unsafe condition exists, **work must not begin** until necessary repairs have been completed, or until the machine can be operated safely.



# SAFETY MANUAL

- 3.8** **⚠ WARNING** The operator is responsible for checking that all safety equipment and guards are in place and in good condition. If found to be missing, incomplete, or damaged, **work must not begin** until the situation has been made safe.
- 3.9** **⚠ WARNING** The operator is responsible for checking that all safety decals are in place and are in readable condition. If found to be missing or unreadable for any reason, steps should be taken to obtain replacements.
- 3.10** **⚠ WARNING** Inspect the tires and brakes on the truck. Never drive a truck with bald or cracked tires, or with weak or worn brakes. If you have air brakes, be sure that the air system is free from leaks and will maintain pressure when driving. Loss of air pressure will cause the brakes to be applied while driving. If driving continues after the brakes are applied, the resulting friction could cause enough heat to start a fire.
- 3.11** Drain moisture from the air tanks that supply the unit's brakes (if so equipped). This is especially important if weather conditions could cause the moisture to freeze. If you lose air pressure because of frozen moisture, the brakes will apply themselves, and you will have to stop driving until the unit is repaired.
- 3.12** **⚠ WARNING** (See Figure 5.) Mount or dismount the pump or truck using the *3-point Rule* (i.e. keep two hands and one foot or one hand and two feet in contact with a secure surface at ALL times).

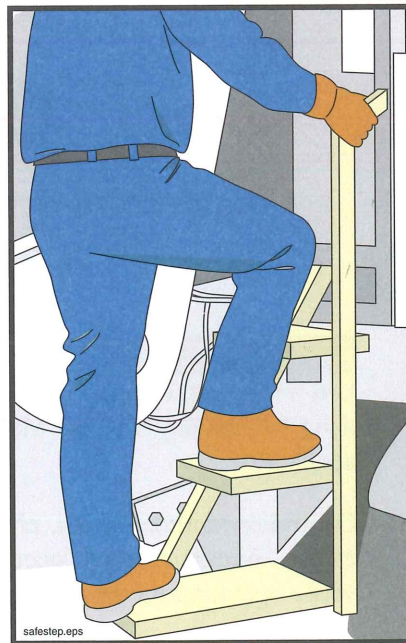
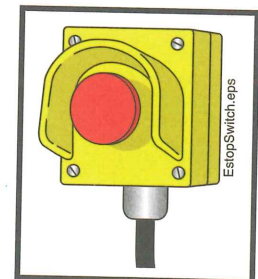

**Figure 5**  
**The 3-point Rule**

- 3.13** **⚠ WARNING** Never mount or dismount the truck or pump while carrying objects that prevent you from using the 3-point Rule. Move the objects separately, if needed.

- 3.14 **⚠ WARNING** If applicable, be sure that outriggers are pinned and locked before traveling. If the locking device is damaged or worn, it should be repaired immediately and the unit **must not be driven until the outriggers can be positively locked** against accidental opening.
- 3.15 **⚠ WARNING** Be sure there is nothing in the cab of the truck (such as empty soda cans, loose tools, etc.) that could interfere with the operation of the vehicle.
- 3.16 Be sure that all road-related safety devices (warning signs, flares, fire extinguisher, etc.) are present and secured for travel.
- 3.17 Be sure all personal protective equipment (hard hat, safety goggles, rubber gloves, etc.) are secured for travel.
- 3.18 **⚠ WARNING** Be sure the windshield and mirrors are clean and free of frost or ice, and that the mirrors are properly adjusted.
- 3.19 **⚠ WARNING** Verify that head lights, tail lights, turn signals, brake lights, backup warning horn, and backup lights are operational.
- 3.20 In some cases you may be asked to operate a machine other than the one with which you are familiar. In these cases, be sure to:
- Know the weight, height, and width of the machine.
  - Have a copy of the operation manual with you.
  - Ask the machine's normal operator, the dispatcher, or your supervisor questions regarding any unusual or unique operational characteristics of the machine.
  - Familiarize yourself with the machine by setting it up in the yard and running the functions, and by familiarizing yourself with the operation manual. This is especially important if the new machine is significantly different than the one you normally operate. Your coworkers depend on you to know the machine.
- 3.21 **⚠ WARNING** Be certain that all loose items on the unit are secured for travel before driving.
- 3.22 **⚠ WARNING** Emergency stop switches (E-stops) should be periodically checked by activating the switch in the yard and confirming that none of the pump functions operate electrically or manually.

**Figure 6**  
Periodically check your emergency stop switches (E-stops) for proper function



## 4. Safety Rules For Towing Trailer-Mounted Concrete Pumps

- 4.1 **⚠ WARNING** Be sure the towing vehicle is sized appropriately for the trailer. It must be heavy enough and have enough braking ability to maintain control at highway speeds and to stop—even on hills. If the trailer is heavier than the towing vehicle, braking distances will be greatly increased (Figure 7).

**Figure 7**  
Do not under size the  
towing vehicle

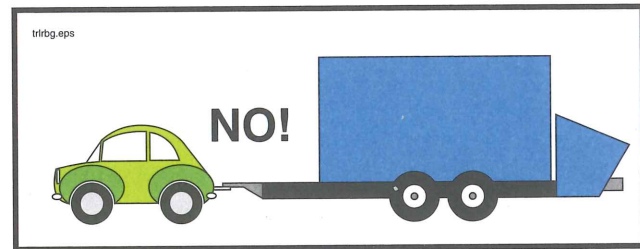

- 4.2 **⚠ WARNING** Never tow a trailer that has concrete in the hopper. The extra weight in the back of the machine will remove weight from the tongue and cause the trailer to fishtail.
- 4.3 **⚠ WARNING** Check the tires, tire pressure, and brakes on the trailer before towing. Never tow a vehicle with cracked or bald tires. A trailer tire blowout can cause loss of control in the towing vehicle.
- 4.4 **⚠ WARNING** Be especially careful on ice or slippery roads when towing a trailer. A skid that would normally be easily correctable can be multiplied by the trailer, causing loss of control.
- 4.5 **⚠ WARNING** Be sure the electrical connections between the towing vehicle and the trailer are sturdy and reliable, and that the lights on the towing vehicle and trailer are working.
- 4.6 **⚠ WARNING** Always use safety chains and break-away protection when towing a trailer.
- 4.7 **⚠ CAUTION** Be aware of local or state regulations regarding mirrors, lights and maximum speed when towing a trailer.
- 4.8 **⚠ WARNING** When towing a trailer, your stopping distance and turning radius are greatly increased. Be aware of this **at all times**.
- 4.9 **⚠ WARNING** When towing a trailer long distances, it is important to frequently check the hitch, hitch pins, couplers, safety clips, towing eyes, wiring, emergency breakaway switch, safety chains, and other accessories, as equipped.
- 4.10 **⚠ WARNING** Be aware of your length when towing a trailer. A common cause of trailer accidents is turning too close to curbs or objects.
- 4.11 **⚠ WARNING** Never back up a trailer without a guide.
- 4.12 **⚠ WARNING** Frequently observe the trailer and watch for unusual swerving or indications of problems, such as a flat tire.



## II. On The Job Site - Safety Rules For Job Setup

### 5. Setting Up A Trailer-Mounted Pump and/or A Separate Pipeline

- 5.1 **The job setup phase sets the stage for most accidents.** Taking a few extra moments to correctly set up the job will improve your chances of having a safe, trouble free day.
- 5.2 **The operator is responsible for the safe operation of the machine.** Notify your employer, the job superintendent, and/or O.S.H.A. if you are being asked to set up in an unsafe manner. **You are never required to take a chance with safety.** You are the **only** person who can determine that the job circumstances under your control are safe.
- 5.3 **⚠ WARNING** Any power connections above 28 volts must be made by a licensed electrician. The supply power and appropriate disconnect boxes are the responsibility of the contractor.
- 5.4 **⚠ WARNING** Electrical power on the job site may be taken only from a fused, grounded disconnect box with a disconnect switch that can be locked against activation. If you will be making repairs to the concrete pump or separate placing boom, first lock out the power at the disconnect box.
- 5.5 **⚠ WARNING** On units equipped with electric motors, **check the power cables every day.** If they are frayed or have open spots in the insulation, replace the wire. If the connectors are worn or loose, have repairs made by a licensed electrician.
- 5.6 **⚠ WARNING** Consider the safe approach and departure of the ready-mix trucks and adjust your setup accordingly. Adjusting your setup position by a few degrees one way or another could mean the difference between a safe approach and an unsafe approach. Some examples of unsafe approaches are: too near an excavation or sticking out into traffic.
- 5.7 **⚠ WARNING** Avoid collisions! Secure the immediate area of the machine from public traffic in accordance with all applicable regulations (warning lights, safety cones, barricades with flashers, etc.).
- 5.8 **⚠ WARNING** Pipelines, end hoses, couplings, and all other material delivery components must be able to withstand the maximum concrete pressure of the pump. Be sure of it! Read and understand the minimum wall thickness chart found in the *Appendix* of this manual. If you don't understand the chart, contact the pipe manufacturer for assistance.
- 5.9 A *concrete delivery hose* is a flexible concrete hose that has two end couplings. An *end hose* is a flexible concrete hose that has one end coupling. See Figure 8.

**Figure 8**  
End hose vs delivery hose

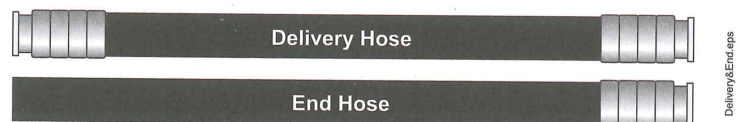

## SAFETY MANUAL

5.10

**⚠ WARNING** Do not use a piece of pipeline, end hose, coupling, or any other material delivery component that is not in good condition. **Replace, do not repair damaged pipes and hoses.** Concrete pipeline system is subject to wear, and the rate of wear is affected by pumping pressure, concrete composition, pipeline material, and other factors. Read and understand the minimum wall thickness chart in the *Appendix* of this manual. **Bursting pipes and concrete escaping under pressure is a serious safety hazard (Figure 9)!**



**Figure 9**  
Delivery system components must be able to withstand maximum pump pressure

5.11

When laying out a pipeline, it is preferable to use an elbow instead of a hose to make direction changes. Elbows have less resistance to flow than hoses, and will therefore reduce the overall pressure required to push the concrete.

5.12

Always use the largest diameter pipeline that is practical, and use steel pipe instead of rubber hose. This will keep the pressure required to push the concrete to a minimum.

5.13

Support the delivery pipeline. Either an "S" transition pipe should be used to bring the pipe to ground level, or **each** section of the pipeline should be supported at the pump outlet level.

5.14

**⚠ WARNING** The sections of pipe nearest the pump are subjected to the highest pressure and the greatest wear. Because of this increase of pressure near the pump, you should install only thick-walled pipe, in like-new condition there. Read and understand the minimum wall thickness chart in the *Appendix* of this manual.

5.15

**⚠ WARNING** The maximum concrete pressure of the pump must be the only factor used to determine what thickness of pipe and what type of ends are needed. In the case of a rock jam or any other type of blockage, the maximum pressure of the pump will be exerted.

5.16

Grooved (Victaulic) ends are **not recommended** for concrete pumping. Read and understand the comparison between heavy duty raised, metric, and grooved ends in the *Appendix* of this manual.

5.17

**⚠ WARNING** If the pipeline remains on the job (as is the case when pumping a high-rise building), the operator is responsible for checking the pipeline for



dents, cracks, wear, and continuous connection each day before the pour begins.

5.18

**⚠ WARNING** In vertical runs, the weight of the vertical sections of pipe must be supported by a thrust block (often called a *deadman*, Figure 10) or other load-bearing device. **Each section of pipeline in a vertical run must be secured from lateral and horizontal movement.**

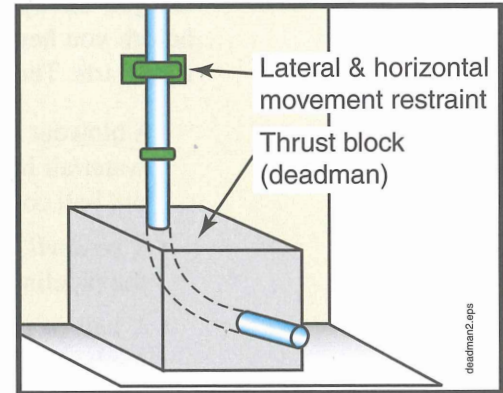

**Figure 10**  
A thrust block (deadman)

5.19

**⚠ WARNING** If you will be unable to see the point of placement, establish a system of communications with the workmen who will be there. Arrange for radio communications, a system of visual or auditory signals (lights or bells), or a signalperson (Figure 11). If a signalperson is used, **agree on hand signals before beginning the pour!**

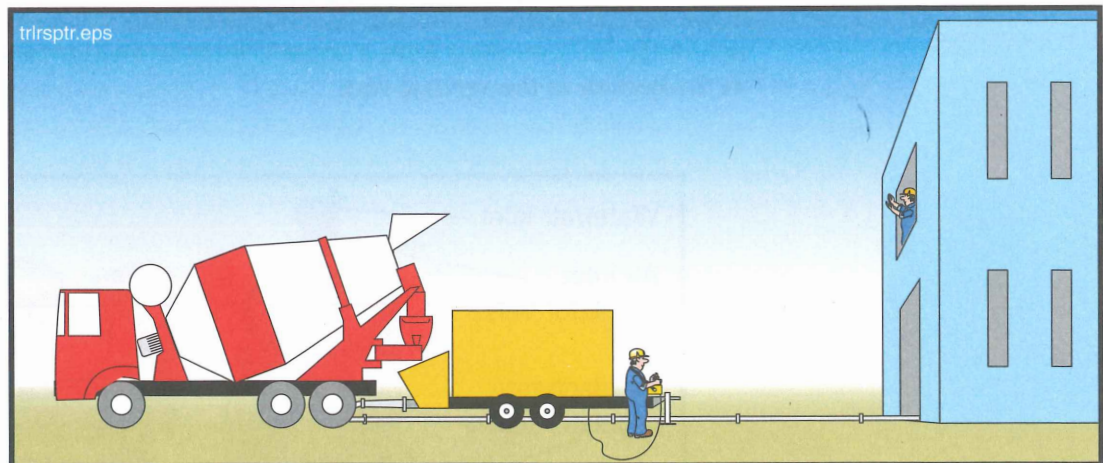

**Figure 11**  
Arrange communications before starting

5.20

**⚠ WARNING** Never leave the machine unattended when it is running or ready to run. If you must leave the area, you must leave someone to monitor the unit. This is especially critical if there are children in the vicinity.

## SAFETY MANUAL

5.21

**⚠ WARNING** Watch for children! It is possible for children to access the machine, but it is not safe for them to do so.

5.22

**⚠ WARNING** If spectators will be near the job, cordon off an area where they will be safe.

5.23

**⚠ WARNING** If you will be cleaning the pipeline with compressed air at the completion of the job, **be sure that you have all the necessary accessories to do the job safely.** If you don't have all of them, make arrangements to get them before you begin to pump. **Do not improvise on this. Make sure** you have the right parts. The minimum accessories include:

- A blowout head with properly sized air discharge regulator valve, and separate water/air inlet. The two openings must be spaced apart far enough that a blow-out ball could not cover both openings at once.
- A *go-devil*, or a hard sponge ball. Regardless of which is used, it **must** fit into the pipeline tight enough that air cannot escape ahead of it.
- A ball or go-devil catcher that will catch the go-devil or ball, or some other method of controlling the discharge while the line is being purged of material. There are two types of catchers (see paragraph 5.24).
- A hose that is rated for the pressure of the air compressor you will use and that is able to connect with both the air compressor and the blowout head. The hose must be in good working condition and must be free of cracks, frays, tears or other damage.
- If you will be cleaning the pipeline with compressed air at the completion of the job, be sure an adequate air compressor is available before starting the job.
- If you will be cleaning a vertical pipeline with compressed air at the completion of the job, you **must have a shutoff valve or switching valve installed at the bottom of the vertical run!**

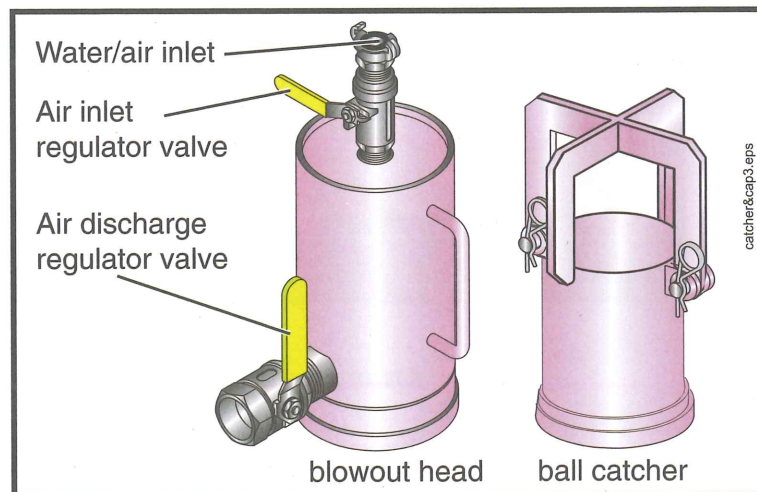

**Figure 12**  
**Ball catcher and blowout head**

5.24

**⚠ WARNING** There are two types of ball catchers. Know which type of catcher you are using. You may need to adjust your cleanout procedure according to which type you have. The two types are as follows:

1. Catchers that stop the ball or go-devil before air can escape, and
2. Catchers that allow the air out of the pipeline after the ball or go-devil has reached the end.

Each type of catcher has advantages and disadvantages (Figure 13).

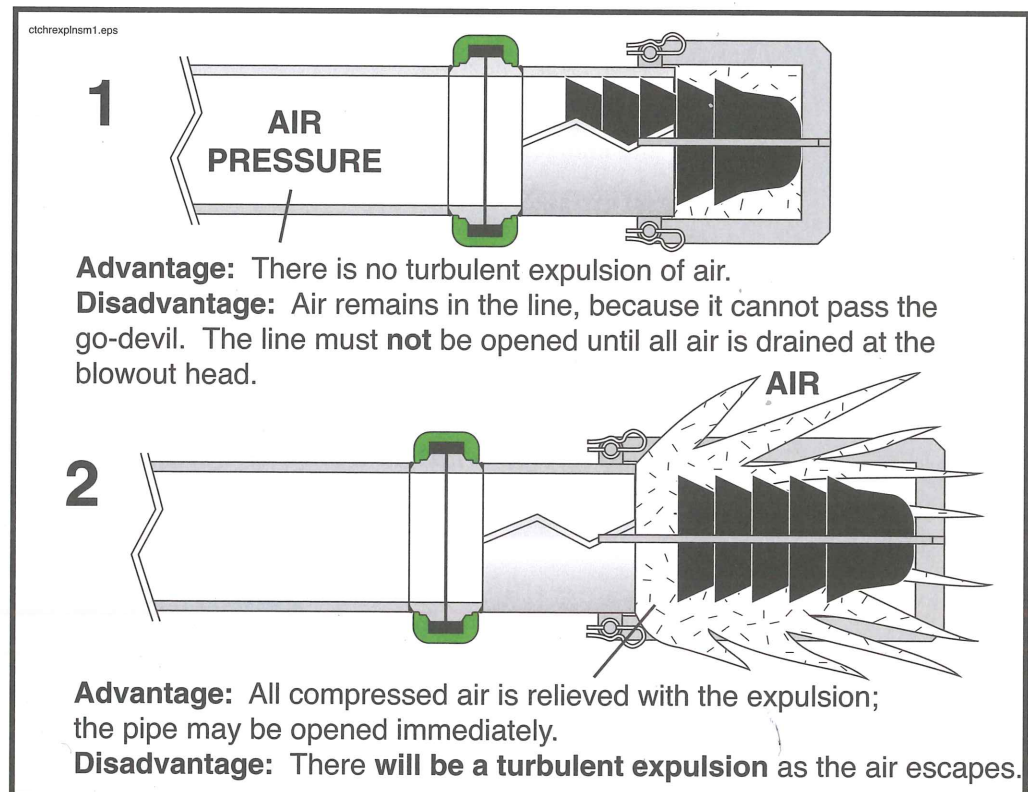

**Figure 13**  
Types of catchers

With catcher type 1, the go-devil stops, but air is still trapped behind it. The advantage is prevention of the sometimes violent expulsion of air at the end of the pipe. The disadvantage is that the air must be drained from the blowout head before the pipe line is safe to open. The pipeline must be controlled; allow no one to open it until all compressed air is relieved.

Catcher type 2 is long enough that the compressed air escapes behind the go-devil. **Note!** This would happen with either catcher when used with a ball instead of a go-devil. The advantage of this is that once you hear the turbulent expulsion, there is no pressurized air remaining in the line, and the line may be opened immediately. The disadvantage is the expulsion itself. In this case, the end of the line must be controlled because flying concrete and aggregate pose a hazard.

Both catchers can be safely used if care is given to the hazards involved.



## III. Concrete Pump Operation

### 6. Safety Rules For Pump Operators

6.1 **WARNING** Only qualified operators are allowed to operate the pump. A Qualified Operator is defined as someone who:

- has reached the age of 18 years (21 for interstate travel);
- is physically and mentally capable;
- has been trained in the operation and maintenance of the pump and the placing boom (if applicable);
- has demonstrated their capabilities to the employer in respect to the operation and maintenance of the pump and placing boom (if applicable); and
- can be expected to perform these duties, as assigned, in a reliable manner.

6.2 **WARNING** Because operators are responsible for the safe operation of the machine, it is crucial that they understand the proper operation of the machine and the safety rules that apply to the job at hand, so the course of action taken in unforeseen circumstances will be a safe one. Only thorough training and supervised job experience can supply the necessary understanding.

6.3 **WARNING** When operating the machine, wear **Personal Protective Equipment (P.P.E., or just PPE)**. (Including \*full face shield and/or \*\* breathing mask, when necessary, as shown in Figure 14.)

\* Full face shield should be used in addition to safety glasses when shotcreting, or any time material is rebounding.

\*\* Breathing mask needed when cement dust (or other toxic dust) is present in the air.

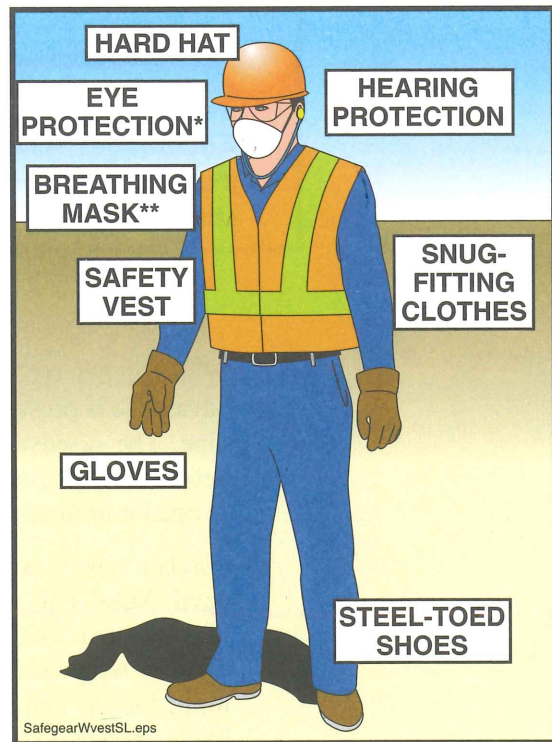

**Figure 14**  
**Wear Personal Protective Equipment (PPE)**

- 6.4 **⚠️ WARNING** All guards, covers, and service flaps must be secured in place during operation.
- 6.5 **⚠️ WARNING** **Electrocution hazard!** If you are operating and lightning moves into the area, seek shelter until the lightning is gone.
- 6.6 **⚠️ WARNING** **Crushing hazard!** Never, ever position yourself between a ready mix truck and the pump! Stand off to the side, so the ready mix driver can see you at all times (Figure 15).

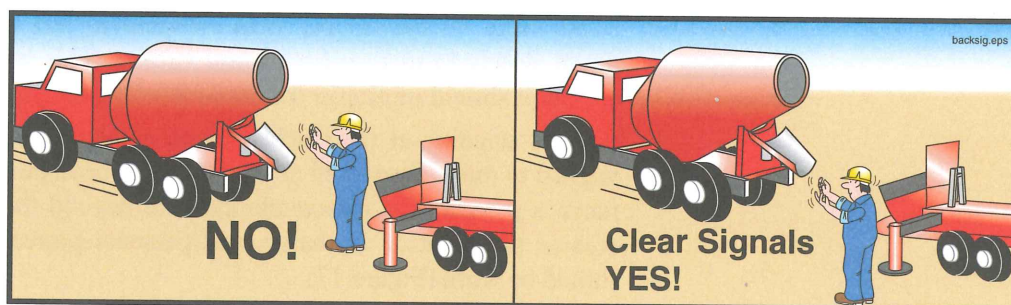

**Figure 15**  
**Never stand between the ready mix truck and the pump**  
**Use clear and concise hand signals**

- 6.7 **⚠️ WARNING** When backing in ready mix trucks, use clear and concise hand signals (Figure 15).
- 6.8 **⚠️ WARNING** If the job requires that you work above ground to operate your machine, an approved fall protection plan must be implemented.
- 6.9 **⚠️ CAUTION** **Loss of hearing!** While standing near a working concrete pump, sound pressure levels may exceed O.S.H.A. standards for constant exposure (Figure 16).

### PERMISSIBLE NOISE EXPOSURES\*

\*Under part 1910.95 Occupational Noise Exposure, (Dept. of Labor) of the Code of Federal Regulations, Chap. XVII of Title 29 (39 F.R. 7006).

DURATION per DAY in HOURS	Sound level in dB (A) Slow response
8	90
6	92
4	95
3	97
2	100
1 1/2	102
1	105
1/2	110
1/4 or LESS	115



**WEAR HEARING PROTECTION!**

**Figure 16**  
**Noise level and exposure time limits**



## SAFETY MANUAL

## 6.10

**⚠ WARNING** Do not let the concrete level in the hopper become low! If air is sucked into the material cylinders, the pump will compress the air. Compressed air always poses a hazard as it is expelled from the hopper or the delivery pipeline (Figure 17). If air is taken into the material cylinders, take the following steps to minimize the hazard:

1. Stop the pump immediately. Hit the emergency stop switch (E-Stop) if that is the quickest way to stop the pump. There will be an expulsion of compressed air the next time the concrete valve shifts, which can be safely absorbed by filling the hopper with concrete.
2. If possible, fill the hopper with concrete to just below the grate, then pump slowly in reverse for several strokes. This will not remove all the air, but it should minimize the amount left in the pipeline.
3. Persons standing at the discharge end or near the delivery line must be warned to move away until all of the air has been purged. Personnel should move a prudent and reasonable distance beyond the end-hose movement area or the point of discharge, and personal protective equipment (PPE) should be worn (Figure 17).
4. When the pump is restarted, pump forward slowly until **all** air is removed from the pipeline. Don't assume that the first little air bubble is the end of the compressed air.
5. Do not allow anyone near the discharge until concrete runs steadily from the end and there is no movement of the delivery system.

If workers are positioned in high or precarious places, warn them to expect a loud sound as the air escapes the pipeline. (Warn them even if they are well away from the discharge.) That way, we can prevent the worker from falling as a result of being startled by the noise.

**Figure 17**  
Remove everyone from  
the discharge area  
whenever air is in the line

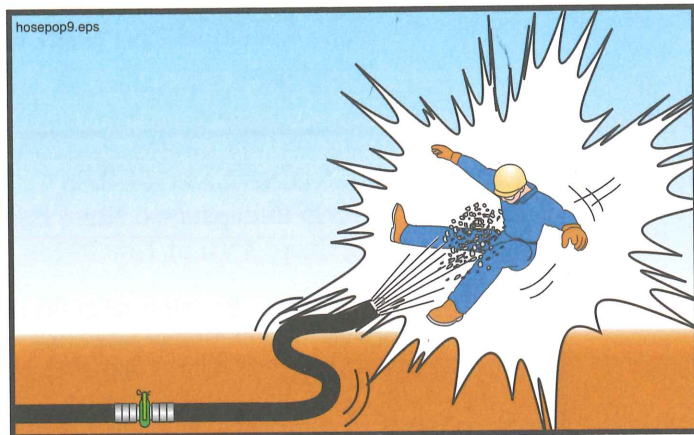

## 6.11

**⚠ WARNING** Air can be introduced into the delivery system in several ways besides being sucked in through the hopper.

For example:

- when initially priming the delivery system;
- when restarting after moving;

- when restarting after adding or removing delivery system;
- when attempting to remove a blockage by rocking the concrete;
- when opening the system to remove a blockage;
- when pumping is stopped and the pipeline is at a downward angle.

6.12

**⚠ WARNING** When initially priming the delivery system, when restarting after moving, when restarting after adding or removing hoses, when attempting to remove a blockage by rocking the concrete, or whenever air has been introduced into the line, warn everyone to stay away from the discharge until material runs steadily. Personnel should move a prudent and reasonable distance beyond the end-hose movement area or the point of discharge, and personal protective equipment (PPE) should be worn (Figure 17).

6.13

**⚠ WARNING** Blockages in the pump or delivery pipeline can create an unsafe condition. Blockages are caused by many different factors, as outlined below.

#### CAUSES OF BLOCKAGES

- **Faulty concrete mix design.** The concrete being supplied may not be a pumpable mix; for example there may be too much sand or too little cement. There may be bleeding or segregation. Some admixtures adversely affect pumpability (e.g., too much air entrainment). If the mix is not pumpable, no amount of operator expertise will make it so.
- **The line size may be inadequate.** The line size should always be at least 3 times larger than the largest aggregate being pumped, or blockages could occur.
- **Worn concrete valve parts.** Worn parts allow the finest material and water to escape back into the hopper when pressure is applied.
- **Pipeline and joint deficiencies.** This would include: dirty pipes (pipes that have not been cleaned properly); worn and leaking pipe joints that allow loss of concrete fines and water; pipes that haven't been properly primed before starting; and too many sections of rubber hose, which increases friction. These are all causes of blockages that can be controlled by the operator.
- **Pump inadequate for the application.** The pump selected for the job may not have enough pressure or horsepower available for the required duty.
- **Concrete setting up in the pipeline.** This may be caused by delays on site (e.g., repairing a broken form), or by attempting to pump old concrete (concrete that was batched hours before pumping and is being kept alive only by adding water and constant agitation). Weather conditions can also affect how quickly the concrete becomes hard. Companies should establish procedures for these situations. A good rule of thumb is: **If in doubt...wash out.**
- **Foreign matter in the concrete.** Pieces of old concrete that break away from mixer fins, unmixed clumps of cement, mixer fins, hammers, and furry mammals are examples of foreign matter that have caused blockages.
- **An inexperienced operator can cause blockages by setting up the job improperly.** For example, if the placing crew is forced to add hose or pipe to reach a far point after the pour is already in progress, there is a great chance of



## SAFETY MANUAL

creating a blockage due to the dry conditions inside the pipe or hose. It is for this reason that the job should be set up so pipe or hose need only be removed (never added) as the day progresses. If dry pipe or hose must be added, it must be lubricated just like the rest of the pipe was lubricated when you first started.

- **An inexperienced or improperly trained placing crew can cause blockages by kinking the end hose.** This type of blockage can lead to serious accidents because the hose may unkind by the force of the pump.
- **The concrete becomes segregated in the hopper.**
  - a. If the concrete is too wet, the cement and fine material get washed from the stone and coarse sand. This mix will not pump. It is for this reason that you should cover the hopper as you wait out a passing storm, never allow a truck mixer to wash out in your hopper, and never add water to the mix.
  - b. If concrete is over vibrated, it will separate. Turn off the hopper vibrator when not actively pumping.

6.14

**⚠ WARNING** Never try to remove a pipeline blockage by applying high pressure to it, because that will cause the blockage to become a plug. If you have a blockage, immediately stop the pump. Stroke the pump several times in reverse. Slowly stroke the pump in forward, and try to dislodge the blockage. If you are moving the blockage, continue to do so slowly and gently. While attempting to clear the blockage, remove all personnel from the discharge area, as air may be introduced into the placing line during this process. If you are unable to move the blockage after a couple of attempts, stop the pump. Continuing to apply high pressure could create a hazardous condition.

6.15

**⚠ WARNING** If the pump or associated equipment develops a problem that creates an unsafe condition, you must stop pumping immediately! Do not restart until the unsafe condition has been remedied.

6.16

**⚠ WARNING** The following points must be observed when locating a blockage.

- Pump in **reverse** for **at least two strokes**, then stop the pump. In the case of a mechanical pump (which cannot be reversed), it is important to carefully follow the manufacturer's instructions for relieving line pressure before any clamp is opened. **Do not allow anyone to open the pipeline** until the pressure is relieved (Figure 18).
- Wear personal protective equipment (PPE) when opening a blocked pipeline.
- Clear the area of nonessential personnel before opening the line.
- In all cases, the blockage must be removed before pumping again. Remember that air will be introduced when the system is taken apart, and keep personnel away from the discharge when restarting.
- Plugs will be found (in the order of likelihood): reducers, hoses, elbows, and pipe.
- If you are tapping the pipe to find the plug, the sound will be a dull thud (tik-tik) rather than a ringing sound (tong-tong) at the spot of the plug, because the

jammed material will keep the pipeline from vibrating. (This method won't find a plug in a hose.)

- To find a plug in a hose: with the pressure relieved, tap or step on the hose to locate the hard spot where the hose is plugged.

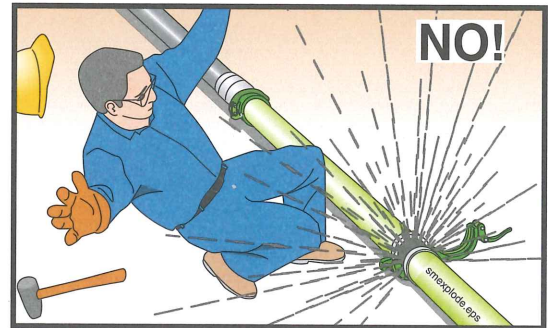

**Figure 18**  
Never open a pressurized pipeline

- 6.17 **⚠ WARNING** It is possible that some pressure will remain in the pipeline after reversing the pump. Use a shovel or pry bar to open the clamps on a blocked pipeline. Wear face protection, and turn away from the pipeline when opening the clamp.
- 6.18 **⚠ WARNING** It would be better to let the pipe be ruined by setting concrete than to risk injury by ignoring safe procedures. Always use safe practices when cleaning pipe. Remember, pipeline is replaceable, you are not.
- 6.19 **⚠ WARNING** **Do not kink hoses.** Kinking will cause the pump to create maximum concrete pressure. **The pump may unkink the hose with force!** (See Figure 19.)

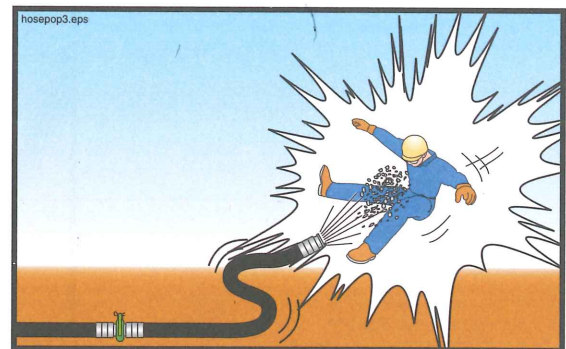
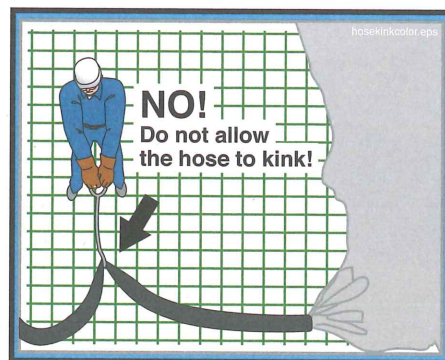

**Figure 19**  
Kinking the hose creates a hazard

- 6.20 **⚠ WARNING** Never use compressed air to clear a blockage! It is unsafe and unnecessary. The pump can develop much more pressure than an air compressor. If the pump pressure cannot move it, air pressure won't either.



# SAFETY MANUAL

6.21

**⚠️ WARNING** Never stand on, sit on, or straddle a pipeline while it's in use, or whenever it is pressurized. Pipeline wears out with each stroke of the pump. If the pipe bursts, you want to be to the side of it, not on top of it (Figure 20).



**Figure 20**  
Never straddle or sit on a pressurized pipeline

6.22

**⚠️ WARNING** Crushing/amputation hazard. Do not remove the water box covers or grates when the machine is stroking (Figure 21). If you must remove the water box cover (to add water, for example), and there is not a bolt-down grate over the water box, then stop the pump and activate the emergency stop (E-stop) so the pump cannot be restarted until you are finished and the covers are back in place. If a bolt-down grate is installed, you may simply stop the pump from stroking before removing the water box covers. Replace the covers before restarting the pump.

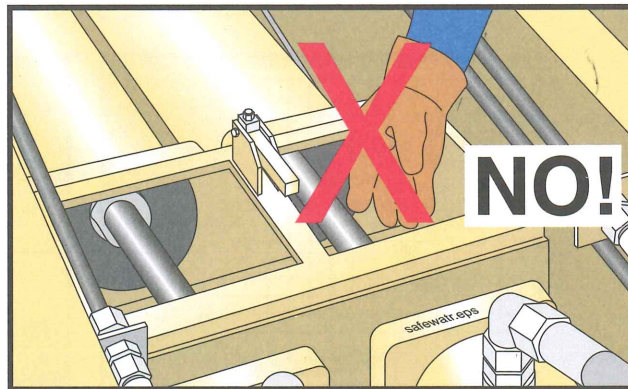

**Figure 21**  
Keep your body out of the water box

6.23

**⚠️ WARNING** Never leave the pump unattended! Before you leave a laborer, ready mix driver, or any other worker alone with the pump for any reason, make sure the worker who you leave with the pump knows:

- the safety rules for a person stationed at the pump (the rules are listed in this *Safety Manual*, beginning on page 35),



- how to stop the pump,
- the location of the emergency stop switches (E-stops),
- how to signal you.

6.24

**⚠ WARNING** To prevent any unintentional movements of the machine, **all** control devices on the operator's panel and the remote control box must be switched off before changing from remote control to local control, or vice-versa. Whenever you are connecting or disconnecting the remote cable, push in the emergency stop switch (E-stop).

6.25

**⚠ WARNING** Crushing/amputation hazard. Never put your hands, feet, or any other body part into the water box, concrete valve, or hopper when the hydraulic system is operational or ready to operate! (See Figure 22.)



**Figure 22**  
**Don't put your body in the machine**

6.26

**⚠ WARNING** Do not work on the hopper, water box, concrete valve, or the hydraulic system unless the drive engine is turned off and the accumulator pressure (if so equipped) has been released! On units with internal combustion engines, the key must be removed. If there is more than one key, you should tag the ignition. On units driven by electric motors, the main disconnect must be locked out according to applicable standards.

6.27

**⚠ WARNING** Never operate the pump blind. If you can't see the point of placement, you must establish a system of communications with the workmen who can see the point of placement. Arrange for radio communications, a system of visual or auditory signals (lights or bells), or a signalperson. If a signalperson is used, **agree on hand signals before beginning the pour!** (Use of the ACPA standardized hand signals is highly recommended.)

# SAFETY MANUAL

## 7. Safety Rules For Shotcreting

7.1 Keep the pump clean. A clean machine runs more efficiently. To enhance the cleaning of your pump, it will help to spray some type of bond breaker on the entire unit before each use (form oil or equivalent). Do not put oil on surfaces that will become hot, such as exhaust manifolds.

7.2 **⚠ WARNING** The nozzle person and nearby personnel should protect themselves by wearing appropriate safety gear, including a full face shield to prevent rebounding concrete from injuring their face and eyes (Figure 23).

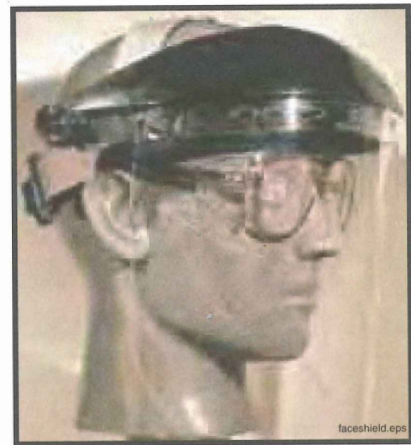

**Figure 23**  
Wear a full face shield for rebound protection

7.3 **⚠ WARNING** Direct the reducers away from the operator and the concrete mixer driver. The line pressures can be quite high during the shotcrete process (Figure 24).



**Figure 24**  
Point reducers away from the operator and driver

7.4 **⚠ WARNING** When practical, the nozzle man and the pump operator should use radios to communicate to facilitate a fast shut-down in the event of a line plug.

7.5 **⚠ WARNING** If setting up on a city street or some other obstacle prevents you from directing the reducers away from your work station, it can be helpful to use rubber matting and bungee cords to cover the reducers and act as a protective cover to protect you and the mixer driver in the event of a line rupture (Figure 25).

**Figure 25**  
Cover reducers and use  
containment boxes for cleanout



7.6

**⚠ WARNING** Crushing/amputation hazard! Always keep the hopper grate in place (Figure 26). Never put your hands, feet, or any other body part into the concrete valve, hopper, or water box when the hydraulic system is operational or ready to operate! Never stand on the hopper grate! In addition, the grate can keep many items from entering the hopper that would become blockages in the line.



**Figure 26**  
Never remove the hopper grate  
while the pump is operating

7.7

**⚠ CAUTION** Overspray always presents a problem during the shotcrete process. Protect personnel and equipment in the area by providing overspray protection, even when you are shooting on the inside. The most commonly used protection is plastic sheeting. It is easy to work with and can be nailed or fastened to almost any surface. Canvas tarps can be used in the same manner, but need to be cleaned frequently. Masonite and plywood also work well in some instances. It can help to over-form the area where shotcrete is to be applied. For example, if a wall is to be six feet high, you can form it to eight feet creating a two-foot area of protection. The same would apply to the end of a wall.

7.8

**⚠ WARNING** Check forms and rebar for stability—both backward and forward—before shotcreting. The rebar cage needs to be tied to something—usually the back form. When the shotcrete wall is being built up, the placed shotcrete wants to sag forward, bringing the rebar with it. If the rebar moves, the form may also move.



## IV. Cleaning The Pump And System

### 8. Safety Rules For Cleaning The Concrete Valve And Hopper

- 8.1 **⚠ WARNING** Wear protective clothing and equipment when cleaning the concrete pump because the lime in concrete can burn your skin. Protect against concrete burns and concrete poisoning by wearing rubber boots and gloves during cleanout or any other time that you will be in contact with the concrete.
- 8.2 **⚠ WARNING** Crushing and amputation hazard! **Never put your hands or any other body part into the concrete valve.** Instead, use water jets and the supplied rake (Figure 27).

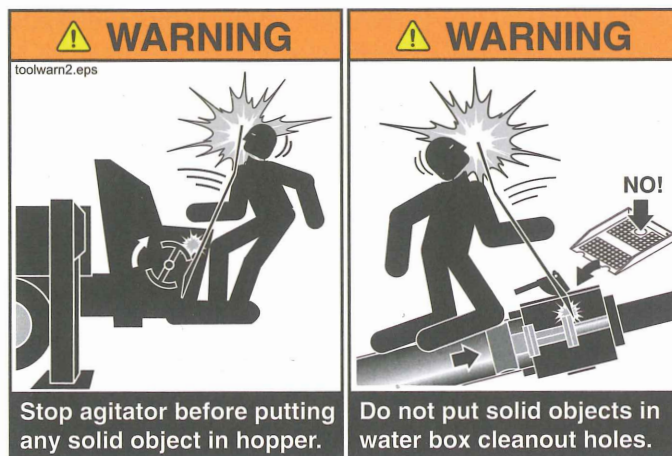

**Figure 27**  
Keep your body parts  
out of the machine

- 8.3 **⚠ WARNING** Never put your hands or any other body part into the machine when the hydraulic system is operational. If you must remove the grate to chip at hardened concrete, you must first disable the system by taking the transmission out of gear and locking the cab door, or stopping the engine, relieving pressure in the accumulator circuit (if so equipped) and securing the controls against unintended operation. Reinstall the grate before restarting the engine (Figure 27).
- 8.4 **⚠ WARNING** Never put a bar or other solid tool into the hopper, water box, or other working system while the hydraulics are operational (Figure 28).

### 9. Safety Rules For Cleaning The Water Box

- 9.1 **⚠ WARNING** Crushing and amputation hazard! Stop the concrete pump before removing the water box covers. If your unit has bolt-down guards, do not remove them for cleaning. If there is not a bolt-down guard over the water box, then stop the pump and activate the emergency stop (E-stop) so the pump cannot

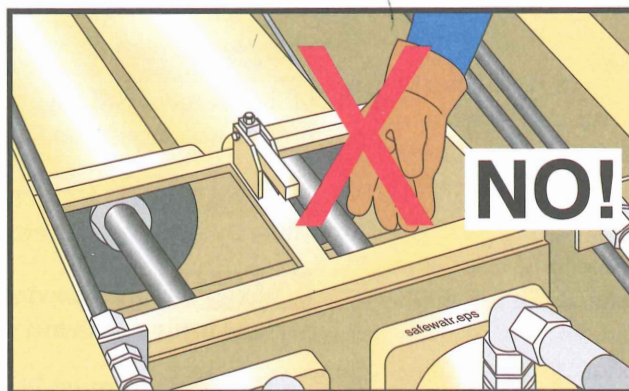

**Figure 28**  
Don't put solid objects into working systems

be restarted until you are finished cleaning and the covers are back in place. If a bolt-down grate is installed, you may simply stop the pump from stroking before removing the water box covers. Replace the covers before restarting the pump.

9.2 **WARNING** Falling hazard! Be sure of your footing when cleaning the water box.

9.3 **WARNING** Crushing and amputation hazard! Do not remove the water box guards for cleaning. Clean the water box with water jets only. **Do not put your hands or any other body part into the water box for cleaning or at any other time when the hydraulic system is operational (Figure 29).**



**Figure 29**  
Keep your hands out of the water box

## 10. Safety Rules For Cleaning A Separately Laid Pipeline

10.1 **WARNING** Flying particle hazard! Clear the discharge area of personnel and equipment before forcing a ball or go-devil through the pipeline, even if you are cleaning with water. Some air will be trapped in the pipeline, and the trapped air will become compressed before discharge.



## SAFETY MANUAL

10.2

**⚠ WARNING** Using compressed air to clean the delivery system should only be done when no other method is practical, or as recommended by the manufacturer.

10.3

**⚠ WARNING** The point of discharge must be controlled. Use a ball catcher or some other containment device at the point of discharge, even when cleaning with water.

**Figure 30**  
Cleaning with compressed air can be extremely hazardous if you don't follow the safety rules

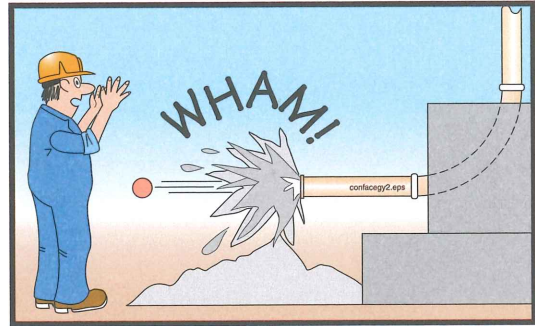

10.4

**⚠ WARNING** If you have to use compressed air for cleaning the line you **must** have all of the necessary accessories. Read and understand the complete safety rules regarding cleaning out with compressed air in this section of this *Safety Manual* starting at paragraph 10.8 on page 26. Cleaning with compressed air should only be done by qualified people. See Figure 30.

10.5

**⚠ WARNING** If the ball or go-devil doesn't come out of the delivery system after applying compressed air, you **must relieve the pipe of air pressure before opening it**. If the bleed-off valve plugs when you are draining the air, the only safe way to proceed is to drill small holes into the pipeline, which will then allow the air to escape. Wear a full face shield when drilling the holes. Pipe you have drilled into is ruined and must be replaced. Drill the holes to relieve the air pressure even if the concrete has set up in the pipe. The pipe is hazardous until the pressure is relieved.

10.6

**⚠ WARNING** Exercise care when tapping on the pipeline to find the location of the cleanout ball. Applying too much force will dent a single wall pipe (making it weak and unsafe) and could break the carbide insert of double wall pipe.

10.7

**⚠ WARNING** It is better to let the pipe be ruined by setting concrete than to risk injury by ignoring safe procedures. Remember, pipeline is replaceable, you are not.

10.8

**⚠ WARNING** **Blowing out with compressed air creates potential hazards! Serious injury or death could result** if you do not adhere to these safety points.

- **Blowing out must be performed under the supervision of a qualified person.** (See the glossary for the definition of *qualified person*.)
- **Blowing out requires two people!** One trained person must be at the inlet end to operate the air insertion, and the other trained person must be near (but safely back from) the discharge point to monitor the discharge and to make sure that no one enters the hazard area.
- **No pipe bends or flexible delivery hoses may be connected to the end of the pipeline during the blowing out process,** unless there is a pre-planned

cleanout station erected to route the discharge into the ready mix truck.

- **The point of discharge must be controlled. Clear the discharge area of personnel and equipment** before beginning the blowing out process. Do not allow anyone to enter the area during the blowout process. If a ball catcher is used, be aware of which type you have, and adjust your procedure accordingly. Ball catcher types are described in paragraph 5.24 on page 13.
- **The concrete outlet must be positioned high enough to permit easy discharge of the material.**
- If you are going to divert the discharge into a discharge pipe system, you must lubricate the discharge line with slurry, or a plug could occur.
- **The pipe cleaning blowout head must be equipped with a properly sized air discharge regulator valve and a separate water/air inlet.** The two openings should be spaced apart far enough that a blowout ball could not cover both openings at once (Figure 31).

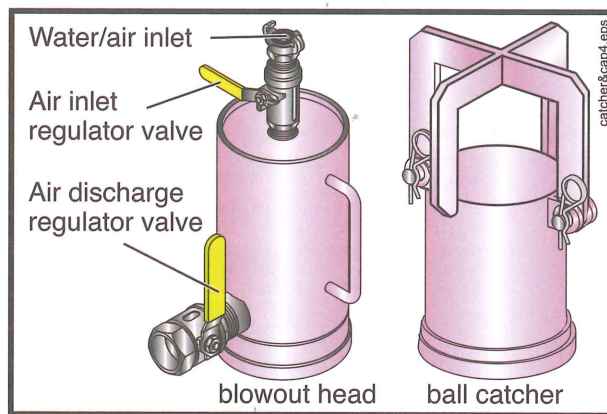

**Figure 31**  
Ball catcher and  
blowout head

- The ball or go-devil must be large enough to prevent compressed air flow around and into the concrete.
- **The pipeline must not be disassembled until it has been completely relieved of air. Be sure of this! (See Figure 32.)**

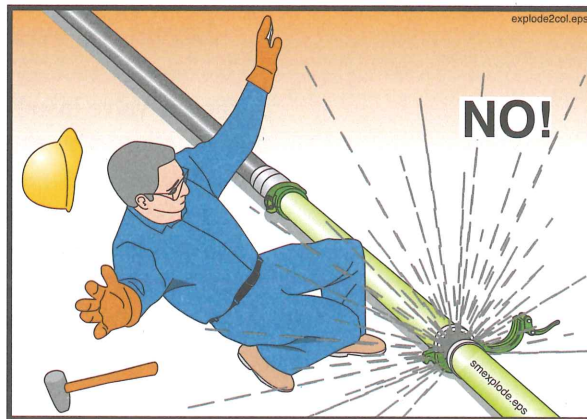

**Figure 32**  
Never open a  
pressurized  
pipeline

- **Do not use compressed air to blow out concrete delivery hose, single pipe sections and short pipelines up to a length of 40 feet.** Hoses will jump and



# SAFETY MANUAL

move unpredictably; short pipelines don't have enough concrete to resist the force of the air, causing it to discharge too quickly, like a cannon (Figure 33).

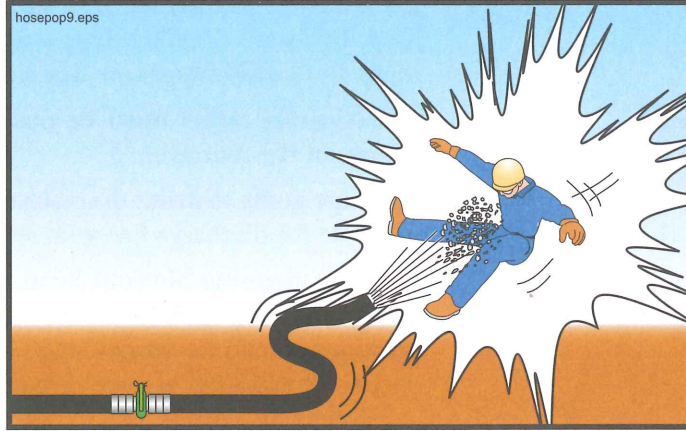

**Figure 33**  
**Never use air to blow out hoses or short pipelines**

- **When air pressure begins to drop rapidly, shut off the air supply from the compressor, and immediately begin bleeding air out of the pipeline.** (The drop in pressure signifies that the pipeline is almost empty of concrete.)

## 10.9

**⚠ WARNING** When blowing out a vertical line, a shutoff valve is required to prevent the following scenario.

1. (See diagram A in Figure 34.) Without a shutoff valve installed, the pipeline is disconnected from the pump. Immediately, the concrete drains out of the vertical sections of pipe, leaving concrete in both horizontal sections, and air trapped in between.
2. (See diagram B in Figure 34.) The ball is inserted, and pushed with compressed air. This also compresses the air that is trapped in the vertical sections of pipe. The trapped air will be violently expelled when it reaches the end of the pipe, but the pipe will not yet be empty.

A shutoff valve installed at the bottom of the vertical run will prevent this hazardous situation. The shutoff valve must be capable of handling the maximum concrete pressure of the pump and, of course, must be installed before the pour begins. Several different styles are available, ranging from a manually operated flat gate that is put into place with a hammer to fully hydraulic types that will also divert the concrete to a different pipeline. With a shutoff valve installed, you can proceed as indicated below.

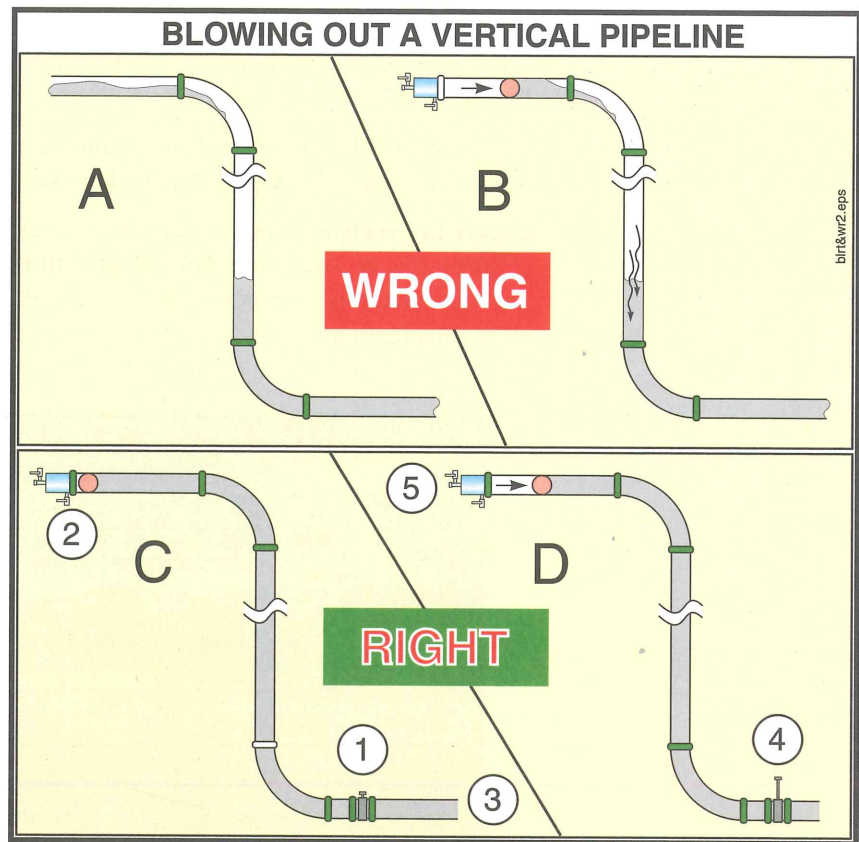

**Figure 34**  
Blowout of a vertical line

10.10

**⚠ WARNING** Blowing out vertical sections of pipe (for example on a high-rise building) requires additional safety precautions.

1. **Know where the discharge area for blowing out will be before the pour begins.** Ready the area and accessories before the pour begins so you will not waste time when pumping is completed.
2. **Blowing out with compressed air requires two qualified persons.**
3. **The persons at both ends of the pipeline must be able to communicate without delays,** which means you must establish communications (for example, with a radio).
4. **When pumping is complete, close the shutoff valve before disconnecting the pipeline from the pump** (Item 1, Figure 34). Failure to do this will cause the concrete to fall out of the vertical sections of pipe, leaving concrete in the horizontal sections of pipe and an air pocket in the vertical sections. This does not apply if you are using a switching (diversion) valve.
5. **Install the ball(s) in the pipeline, secure the blowout head and hook up the air compressor. Do not apply the air yet!** (Item 2, Figure 34.)

## SAFETY MANUAL

6. If you will be diverting the discharge to a cleanout area, lubricate the discharge line with slurry, or a plug could occur.
7. **Position the ready mix truck at the cleanout standpipe**, or install the ball catcher or other containment device at the end of the discharge line. (Item 3, Figure 34.)
8. **Clear the discharge area of personnel.** You must allow no one to enter the discharge area until the pipeline is depressurized.
9. **Divert the vertical pipe line to the cleanout area and secure the discharge (Figure 35), or open the shutoff valve in the delivery pipe line now.** Allow gravity to start the concrete moving through the discharge line. As the concrete falls from the vertical sections, it will take the ball with it, making it impossible to trap air in the line. (Item 4, Figure 34.)



**Figure 35**  
**Divert vertical pipeline to the cleanout area and be sure to secure the discharge before continuing**

10. **Apply the compressed air to the pipeline.** Close communications must be maintained at this time. Add only enough air to keep the concrete moving. Do not allow the concrete to accelerate. (Item 5, Figure 34.)
11. **When concrete starts to accelerate, shut off the air supply from the compressor, and open the air regulator to bleed air from the line.** Rapidly accelerating concrete indicates that the pipeline is almost empty. After the ball has been expelled from the pipeline, leave the air regulator open to be sure that all air is removed from the system.
12. All the rules for blowing out found in Point 10.8 on page 26 also apply to blowing out a vertical pipe line. These rules are in addition to the general cleaning a pipeline with compressed air rules.

10.11

**⚠ WARNING** Never use compressed air to attempt to clear a blockage! It is unsafe and unnecessary. If the pump pressure can't move it, air pressure won't either.



## V. Maintenance Of The Machinery

### 11. Safety Rules Regarding Inspection

- 11.1 **⚠ WARNING** Visually inspect your unit each day before it is put into operation. If any problem is found that will affect the safe operation of the pump, don't use the pump until it is repaired!
- 11.2 **⚠ WARNING** If safety decals are faded, missing, damaged, or otherwise unreadable, they must be replaced immediately. Contact the manufacturer of your unit to obtain replacements.
- 11.3 **⚠ WARNING** If safety devices or guards are removed for inspection purposes, they must be replaced before someone uses the machine.
- 11.4 **⚠ WARNING** Pay attention to the operation manual and manufacturers service bulletins regarding maintenance and inspection procedures and intervals.
- 11.5 **⚠ WARNING** If inspection reveals something that looks wrong, or even suspicious, report it to the manufacturer for consideration. Don't just assume that it's okay.
- 11.6 **⚠ WARNING** Visual inspection of the concrete pump circuits and safety devices should be done daily. Hands-on inspection and documentation of results should be done weekly, or at least when preventive maintenance is scheduled.
- 11.7 **⚠ WARNING** Do not neglect the delivery pipeline, clamps, or hoses. Check them often for wear, dents, and frays. Never send a unit to a job with a worn or damaged delivery system. For single wall pipes, ultrasonic thickness testers are more accurate than the tap method.

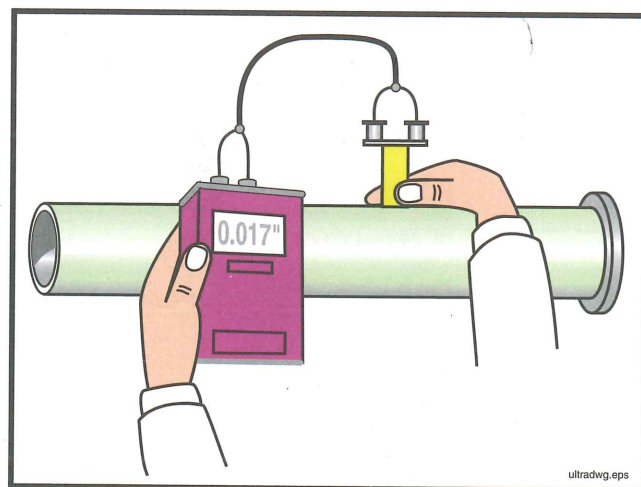

††

**Figure 36**  
Check delivery system wall thickness with  
an ultrasonic thickness tester

## 12. Safety Rules Regarding Scheduled Maintenance

**12.1** **⚠ WARNING** Proper and timely maintenance is important to the safe operation of a concrete pump. The proper procedures are outlined in the operation manual supplied with the pump. Do not put it off. Do not treat it lightly. Do not fudge results. The lives of the operator, oiler, and workers on the job are depending on it.

**12.2** **⚠ WARNING** Keep the machine clean! Oil spills, grease, loose tools, and displaced accessories are hazards.

**12.3** **⚠ WARNING** Pins should be used on all delivery system clamps. Clamps that will hang over workers, and clamps used on system that will be dragged shall be pinned (Figure 37).

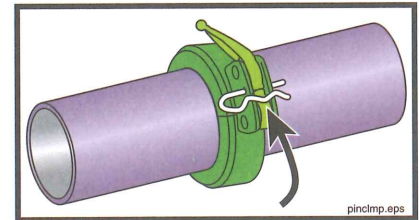

**Figure 37**  
Pin the clamps

**12.4** **⚠ WARNING** Be sure that you are installing the correct clamps for the types of pipe ends used. Never try to mate dissimilar pipe ends unless using a clamp specifically made for this purpose. See the comparison regarding weld-on ends on page 46 in the *Appendix* of this manual.

**12.5** **⚠ WARNING** When using new pipe and/or hose on the machine, be sure that it is capable of handling the maximum concrete pressure of the pump.

**12.6** **⚠ WARNING** If safety devices or guards are removed for servicing, they must be replaced before the machine is put back in service.

**12.7** **⚠ WARNING** Do not change the maximum relief valve setting on any hydraulic circuit without permission from the manufacturer. **Never** change an accumulator circuit pressure setting without specific instructions from the manufacturer.

**12.8** **⚠ WARNING** Never make unauthorized modifications to structural members or pressure circuits.

**12.9** **⚠ WARNING** You must **replace, not repair** damaged hydraulic or concrete hoses or pipes.

**12.10** **⚠ WARNING** Never try to repair a machine using worn, damaged, or defective components.

**12.11** **NOTICE** Never allow welding current to travel through bearings or hydraulic cylinders. Keep the ground cable on the component that is being welded.

12.12

**NOTICE** Electronic components can be destroyed by welding current. Before welding on the unit, you must disconnect the battery cables, and unplug all radio remote control power wires. If in doubt, contact the Service Department of the manufacturer for instructions **before** proceeding.

## 13. Safety Rules When Servicing The Machinery

13.1

**WARNING** Repairs should be carried out by qualified workshop personnel. (See the glossary for the definition of *qualified personnel*.)

13.2

**WARNING** Read and understand the maintenance procedures in the operation manual **of the machine before attempting any repairs**. If in doubt, call the manufacturer. Incorrectly done repairs affect the safe use of the machine.

13.3

**WARNING** Burn hazard! **Never work on a hot hydraulic system.**

13.4

**WARNING** Falling hazard! If you cannot work at ground level, you must find and use a suitable work platform, a tie-off harness system, or otherwise secure yourself from falling.

13.5

**WARNING** If maintenance work requires that you use a crane, hoist, fork truck, or similar machine, read and understand the safety regulations for that equipment.

13.6

**WARNING** Only operators should operate the unit. If work on the machine requires that it be operated and you are not qualified as an operator, you must get someone who is qualified to assist you.

13.7

**DANGER** Electrocuting hazard! **Repair work on electrical systems over 28 volts must be done by qualified electricians.**

13.8

**WARNING** Explosion hazard! **Be sure that you understand the potential danger of spring-loaded or compressed-gas components before you service them.** (Examples: nitrogen accumulators, gas springs for toolbox doors, tires, brake chambers.) If you don't know the dangers, call the manufacturer **before** beginning work!

13.9

**WARNING** If you will be working in a hidden area inside the machine, lock it out as follows.

- With a gas or diesel engine, remove the ignition key and place a *Do Not Operate* sign on the controls. Carry the key with you.
- With an electrically driven pump, lock out the main breaker and tag the controls.

The above rules are one simple Lock Out-Tag Out procedure. A procedure may also be provided in the operation manual for the unit and there may be state or local regulations that require a more advanced or stringent Lock Out-Tag Out program. Be aware of the regulations in your area.



# SAFETY MANUAL

- 13.10** **⚠ WARNING** Never activate the system hydraulics without checking if another workman is in a hidden position. Always yell “clear” before starting the engine or electric motor, and allow time for response.
- 13.11** **⚠ WARNING** Never work on a pressurized hydraulic system. Stop the engine or electric motor, relieve the accumulator circuit and verify zero pressure on the gauge (if so equipped), and be sure that no hydraulic components are loaded, (i.e., outrigger supporting the unit) before you open the hydraulic system.
- 13.12** **⚠ WARNING** Never use gasoline or diesel fuel as a cleaning solvent. This is critical to remember when cleaning hydraulic oil reservoirs, because gas and diesel fuels are highly explosive and traces left in the oil may ignite when compressed!
- 13.13** **⚠ WARNING** Remember to mount and dismount the unit using the 3-point Rule. One hand and two feet or two hands and one foot are to be in contact with a secure surface at all times (Figure 38).



**Figure 38**  
**The 3-point Rule**

- 13.14** **⚠ WARNING** Always use the correct tools for the job. Tools should be kept clean and in good condition.
- 13.15** **⚠ WARNING** If you see a coworker engaging in an unsafe practice, warn him about the dangers. Safety is always in the hands of those on the job!
- 13.16** **⚠ WARNING** After any repair is completed, test the function of the repaired part to be sure that repairs were done correctly.



## VI. Coworker Safety

### 14. Safety Rules For Workers Assigned To The Pump.

14.1

**⚠ WARNING** You must know how to stop the pump. Have the operator show you the locations of the emergency stop switches (E-stops) (Figure 39).

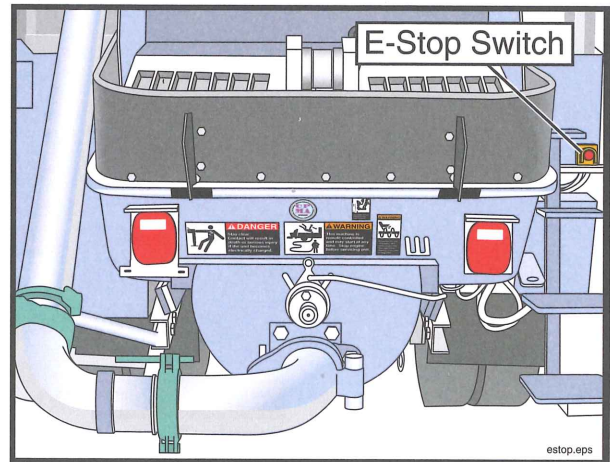

**Figure 39**  
Know how to stop the unit in an emergency

14.2

**⚠ DANGER** You should wear the same personal protective equipment as the operator. Goggles, hard hat, ear protection, and rubber gloves are especially important when working near the hopper, (including \*full face shield and/or \*\* breathing mask, when necessary, as shown in Figure 40).

\* Full face shield should be used in addition to safety glasses when shotcreting, or any time material is rebounding.

\*\* Breathing mask needed when cement dust (or other toxic dust) is present in the air.



**Figure 40**  
Wear the same personal protective equipment as the operator

## SAFETY MANUAL

14.3

**⚠ WARNING** Crushing hazard. Never, ever position yourself between the ready mix truck and the pump! Stand to the side, where the driver can see you (Figure 41).



**Figure 41**  
Never stand between the ready mix truck and the pump

14.4

**⚠ WARNING** When backing in ready mix trucks, use clear and concise hand signals (Figure 42).

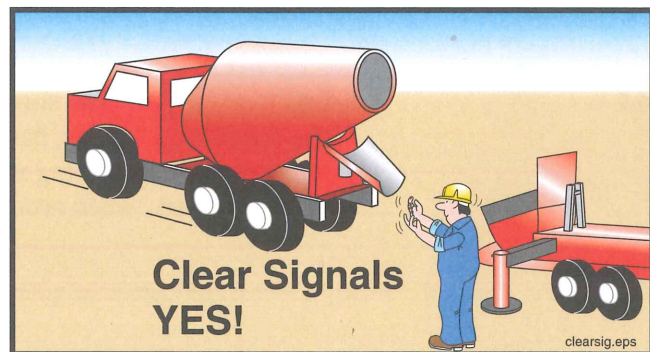

**Figure 42**  
Use clear, concise  
hand signals

14.5

**⚠ WARNING** If handling the chutes of a ready mix truck, keep your hands clear of the hinged areas.

14.6

**⚠ WARNING** Do not allow the ready mix driver to put concrete in the pump hopper until the pump operator gives him the 'okay.' Filling the hopper early can cause the pump to plug.

14.7

**⚠ WARNING** If you see foreign material that could create a blockage coming from the ready mix truck, alert the operator to stop the pump. Do not attempt to remove the material from the hopper or grate while the hydraulic system is ready to work. (See Point 14.16 on page 39.) If necessary, depress the E-stop button to stop the pump and alert the operator.

14.8

**⚠ WARNING** Never allow the ready mix driver to clean out in the hopper, because it can create a blockage. (Water will wash the cement and fine sand from the course aggregate causing segregation.)

14.9

**⚠ WARNING** Do not operate the pump unless you are also a trained operator and the regular operator has released the controls to you. **There must not be more than one operator at a time.** This does not apply to stopping the pump or boom if there is a need to do so.

14.10

**⚠ WARNING** Do not let the concrete level in the hopper become low! If air is sucked into the material cylinders, the pump will compress the air. Compressed air always poses a hazard as it is expelled from the hopper or the delivery pipeline (Figure 43). If air is taken into the material cylinders, take the following steps to minimize the hazard:

1. Stop the pump immediately. Hit the emergency stop switch (E-stop) if that is the quickest way to stop the pump. There will be an expulsion of compressed air the next time the concrete valve shifts. If possible, fill the hopper with concrete to help contain the expulsion. Do not put your face directly over the hopper.
  2. Alert the operator of the problem. It is the operator's job to know the procedures for safe removal of air from the pump and delivery system. These procedures include pumping in reverse for a couple of strokes.
  3. Persons standing at the discharge end or near the delivery line must be warned to move away until all of the air has been purged. Warn them to stay a reasonable and prudent distance beyond the reach of the end hose or point of discharge (Figure 43).
  4. When the pump is restarted, don't assume that the first little air bubble is the end of the compressed air.
  5. Do not allow anyone near the discharge until concrete runs steadily from the end and there is no movement of the delivery system.
- If workers are positioned in high or precarious places, warn them to expect a loud sound as the air escapes the pipeline. (Warn them even if they are well away from the discharge.) That way, we can prevent the worker from falling as a result of being startled by the noise.

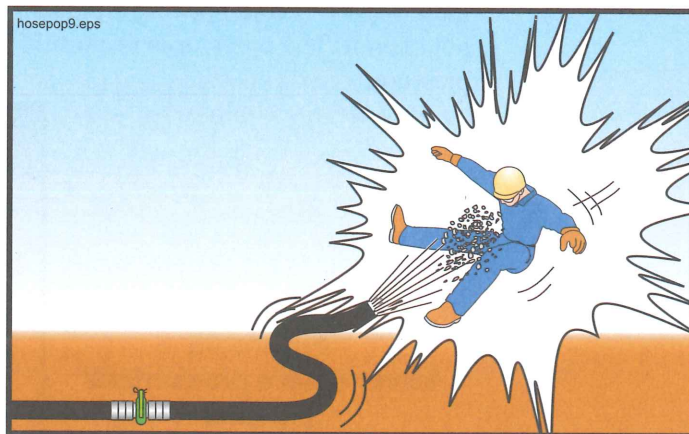

**Figure 43**  
**Remove everyone from the discharge area**  
**whenever air has been introduced into the line**



## SAFETY MANUAL

14.11

**⚠ WARNING** When initially priming the delivery system, when restarting after moving, when restarting after adding or removing hoses, or whenever air has been introduced into the line, warn everyone to stay away from the discharge until concrete runs steadily and there is no movement of the delivery system. Personnel should stay back a reasonable and prudent distance beyond the reach of the end hose or point of discharge (Figure 43). Air will be in the line when first starting, when restarting after moving, when a blockage has been successfully removed by rocking the concrete, and after the line has been taken apart or opened for any reason.

14.12

**⚠ WARNING** Never use compressed air to clear a blockage! The operator is responsible for knowing the safe blockage removal procedures. It is unsafe and unnecessary to use compressed air. If the pump pressure cannot move it, air pressure won't either.

14.13

**⚠ WARNING** Never stand on, sit on, or straddle a pipeline while it's in use, or whenever it is pressurized. Pipeline wears out with each stroke of the pump. If the pipe bursts, you want to be to the side of it, not on top of it (Figure 44).



**Figure 44**  
Never straddle or sit on  
a pressurized pipeline

14.14

**⚠ WARNING** Expulsion hazard! Never open a pipeline that is under pressure (Figure 45). The pump must be run in reverse for at least two strokes and then stopped before opening a pipeline. If the pipeline is pressurized with air, do not open it. The operator is responsible for knowing how to safely release the air pressure.

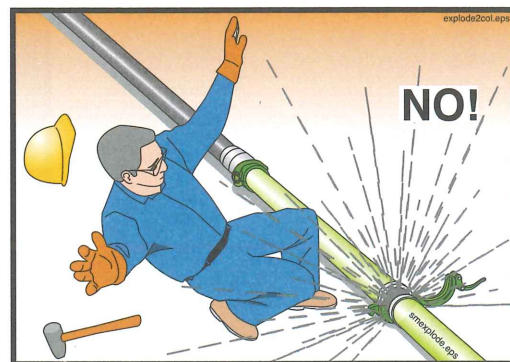

**Figure 45**  
Never open a pressurized  
pipeline

14.15

**⚠ WARNING** Be careful when handling pipeline or any other heavy object. Learn how to lift without using your back. Get assistance if needed.



14.16

**⚠ WARNING** Crushing/amputation hazard! Never put your hands, feet, or any other body part into the water box, concrete valve, or hopper when the hydraulic system is operational or ready to operate! Never stand on the hopper grate! (See Figure 46.)



**Figure 46**  
Never put your body in the machine!

14.17

**⚠ WARNING** Never lift or remove the hopper grate for any reason (Figure 47).

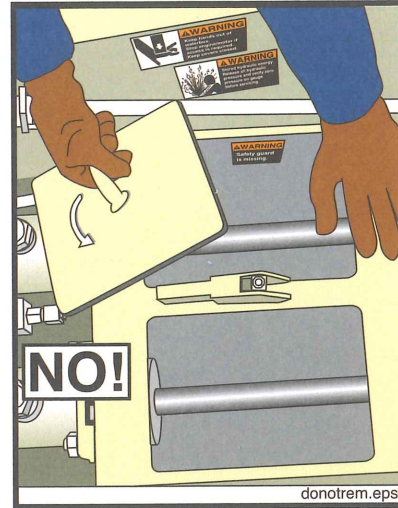

**Figure 47**  
Lifting hopper grate exposes the agitator and the concrete valve

# SAFETY MANUAL

14.18

**⚠ WARNING** Do not remove the water box covers or grates when the machine is stroking (Figure 48). Do not remove the water box cover (to add water, for example), until the operator has disabled the machine. Replace the covers before the operator restarts the pump.



**Figure 48**  
Do not remove the water box covers when the machine is stroking

14.19

**⚠ WARNING** Mount or dismount the pump or truck using the *3-point Rule*. One hand and two feet or two hands and one foot are to be in contact with a secure surface at all times (Figure 49).



**Figure 49**  
The 3-point Rule

14.20

**⚠ WARNING** Keep unauthorized personnel off of the pump.

## 15. Safety Rules For The Placing Crew

### 15.1

**⚠ WARNING** Wear Personal Protective Equipment (P.P.E., or just PPE) when working around a concrete pump (Figure 50). The gloves should resist concrete lime burns. If you will be working **in** the concrete, protect your feet and hands with rubber boots and gloves (including \*full face shield and/or \*\* breathing mask, when necessary, as shown below).

\* Full face shield should be used in addition to safety glasses when shotcreting, or any time material is rebounding.

\*\* Breathing mask needed when cement dust (or other toxic dust) is present in the air.

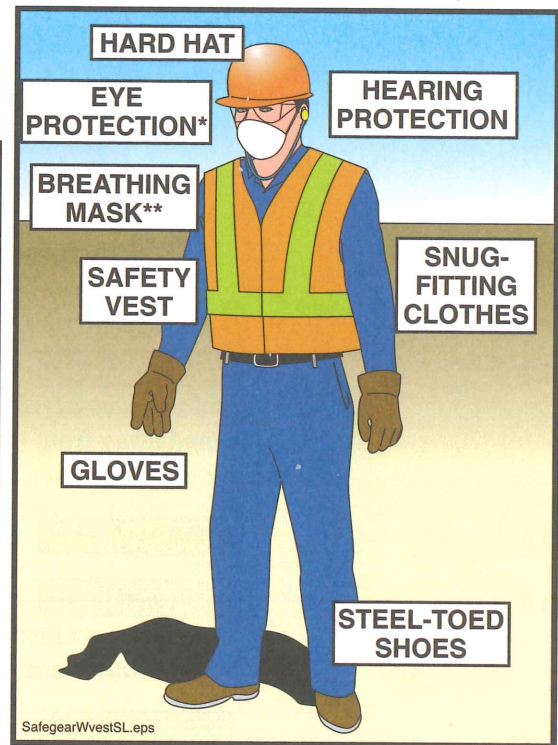

**Figure 50**  
Wear Personal Protective Equipment (PPE)

### 15.2

**⚠ WARNING** When the operator is initially priming the delivery system, restarting after moving, restarting after adding or removing pipes or hoses, or any time that air has been introduced into the delivery system, stand a reasonable and prudent distance away from the tip hose or point of discharge. Do not get near the discharge until material runs steadily and there is no movement of the delivery system. (Figure 51). Compressed air in the line can cause rubber hose to move violently. If the operator tells you that air is coming in the delivery system, proceed as follows:

- Get to ground level (if in a high place) and remain well away from the discharge or at least take cover.
- Stay away from the discharge. Be sure that **all** the air is gone before getting near the point of discharge again. It is the operator's job to know when it's safe to go back to normal pumping.



# SAFETY MANUAL

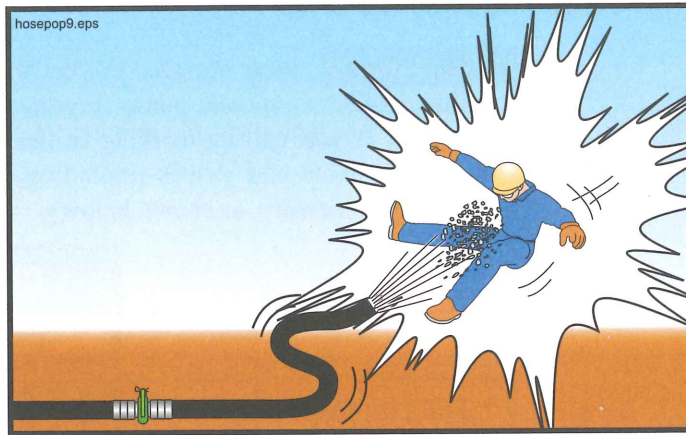

**Figure 51**  
**Stay away from the point of discharge when starting or restarting, and when there's air in the pipeline**

**15.3** **⚠ WARNING** Never use compressed air to clear a blockage! It is unsafe and unnecessary. If the pump pressure cannot move it, air pressure won't either. Stand away from the discharge and the line if anyone attempts to use compressed air in this manner.

**15.4** **⚠ WARNING** Do not look into the end of a plugged hose or pipe!

**15.5** **⚠ WARNING** When the pump crew is using compressed air to clean the boom or system pipeline, stay away from the discharge area. **Never try to hold down a pipe or hose that is being cleaned with air.**

**15.6** **⚠ WARNING** Never open a pressurized pipeline (Figure 52). The pump operator must release the pressure before you open the line: If the line is pressurized with compressed air, let the operator release the pressure and verify that the air has escaped before you proceed.

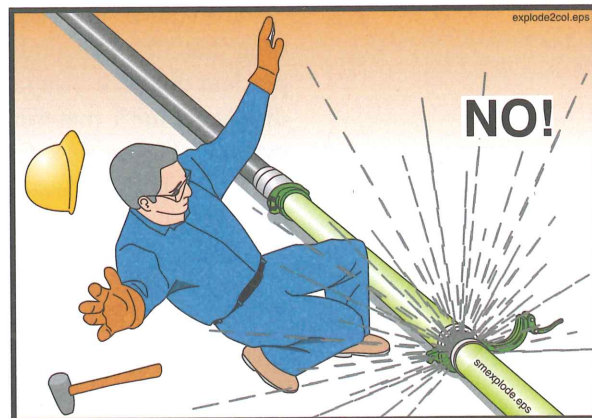

**Figure 52**  
**Never open a pressurized pipeline**

**15.7** **⚠ WARNING** After removing pipe sections you must **reassemble using gaskets and clamps**. Pipelines assembled without gaskets will leak cement and water, which can cause a blockage.



15.8 **⚠️ WARNING** Concrete is being moved through the delivery system by pressure. Failure of a pipe, clamp, hose, or elbow is possible. For this reason, spend as little time as possible standing near the pipeline, and wear protective clothing.

15.9 **⚠️ WARNING** Do not kink the end hose. Kinking will cause the pump to create maximum concrete pressure. The pump may unkink the hose by force! (See Figure 53.)

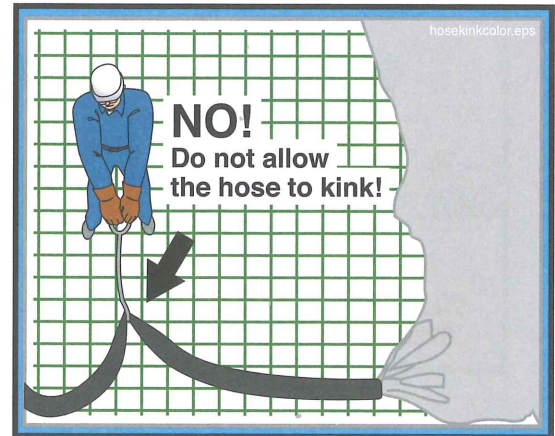

**Figure 53**  
Never kink the hose;  
Never hold the hose with your shoulder

15.10 **⚠️ CAUTION** Be careful when handling pipeline or any other heavy object. Learn how to lift without using your back. Get assistance if needed.

15.11 **⚠️ WARNING** Falling hazard! When pouring columns, slabs, or walls above ground, secure yourself from falling.

15.12 **⚠️ WARNING** Never stand on, sit on, or straddle a pipeline while it's in use, or whenever it is pressurized (Figure 54). Pipeline wears out with each stroke of the pump. If the pipe bursts, you want to be to the side of it, not on top of it.

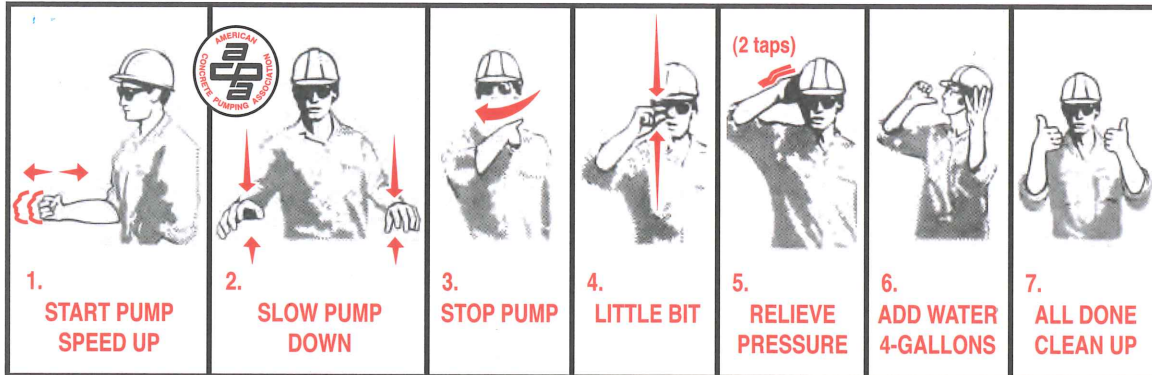

**Figure 54**  
Never straddle or sit on a pressurized pipeline

# SAFETY MANUAL

**15.13** **⚠ WARNING** To avoid confusion and conflicting signals, only one person should act as a signalperson (give operational signals to the pump operator). However, the operator is trained to obey a stop signal from anyone and everyone.

**15.14** **⚠ WARNING** Before the pour begins, the hose person, the signalperson, and the operator should agree on the hand signals (Figure 55).



ACPAhandsigsmallline2.eps

**Figure 55**  
**Recommended ACPA hand signals**

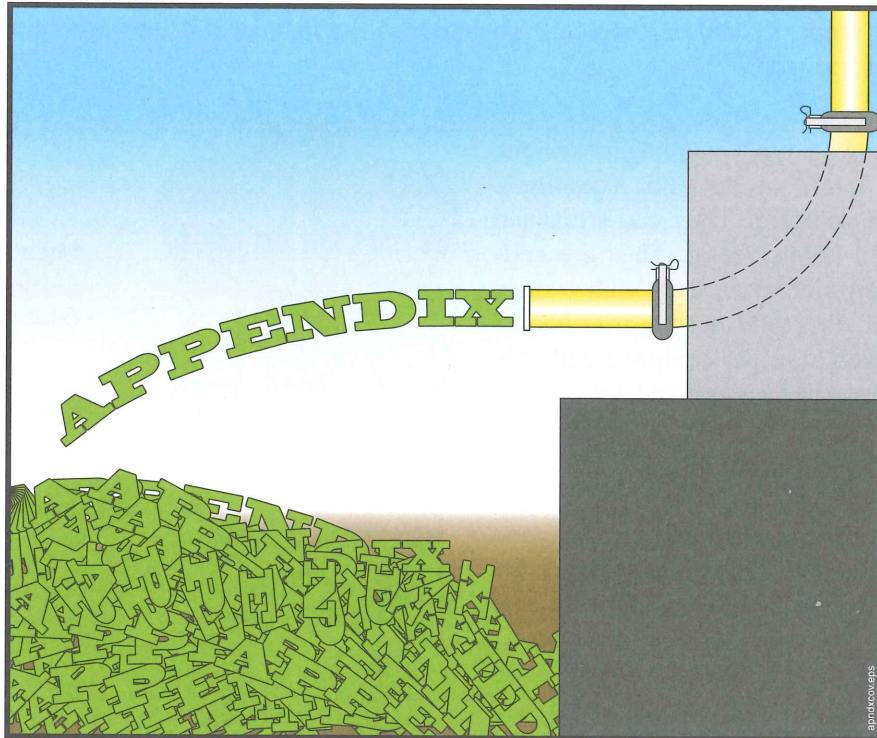

## Appendix

VII.	Weld-On Ends/Coupling Comparison . . . . .	46
VIII.	Minimum Pipe Wall Thickness Chart . . . . .	47
IX.	Glossary Of Terms . . . . .	48
X.	Recommended ACPA Hand Signals . . . . .	53
XI.	Bibliography . . . . .	53



**VII. Weld-On Ends/Coupling Comparison**

Shown is a comparison among commonly used ends/couplings. No two ends shown can be joined without the use of an adapter pipe or a special adapter clamp. Clamps and pipe strength must also be considered when determining proper system requirements. The ratios shown in the text below represent the safety factor from burst:working pressures.

1. Male/female o-ring type couplings have the highest pressure rating of the ends commonly used for concrete pumping. They can withstand 4350 PSI @ a 2:1 safety factor. They are self-aligning and waterproof when used with o-rings in good condition. Typically not used on booms because of their weight. Pipes equipped with this style coupling cannot be swapped end-for-end.

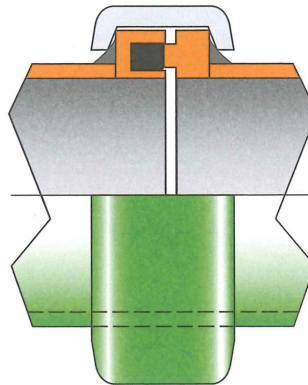

Male / Female O-Ring (shown with clamp)

2. Heavy-Duty couplings are designed for pressures up to 2250 PSI @ 2:1. They have 20% more contact area than metric couplings, and a tapered face that draws the pipe sections together during assembly. Both the ends and clamps weigh more than metric style, and therefore should not be used on booms without consulting the manufacturer.

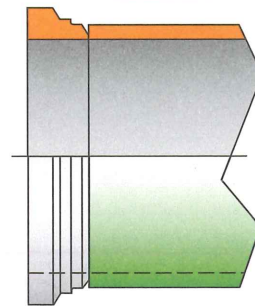

Heavy-Duty

3. Metric couplings are designed for pressures up to 1400 PSI @ 2:1. They have 85% more contact area than grooved couplings. The face is flat and will not draw pipe together. Although they have a raised edge, they are not compatible with Heavy-Duty couplings unless a special clamp or an adapter pipe is used to change from one style to the other. Metric connections are standard equipment on booms because of the weight savings compared with other styles.

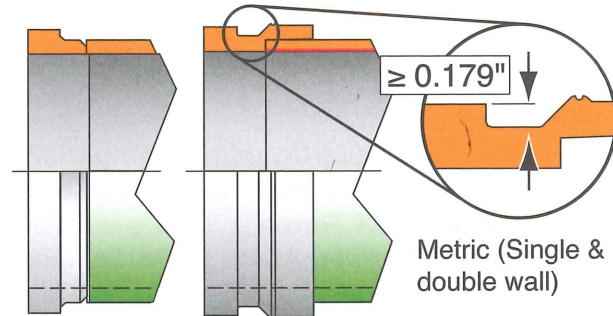

Metric (Single & double wall)

4. Grooved (Victaulic) couplings (lip height of 0.15" or less) are designed for pressures only up to 750 PSI @ 2:1. The recessed groove is hard to clean when changing pipe on a job. The weld-on end fails before the pipe because the groove is cut into the pipe thickness, making it the weakest spot. Grooved couplings are not recommended for concrete pumping applications.

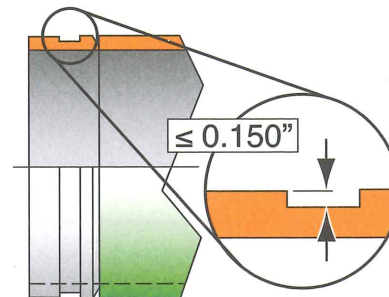

Grooved; flange height equal to or less than 0.150", cut directly into pipe wall. NOT ALLOWED for concrete pumping per ASME B30.27

**NOTE:** All pressure ratings listed refer to 5-inch (125mm) diameters in like-new condition. Other pressures would apply to other diameters.



## VIII. Minimum Pipe Wall Thickness Chart

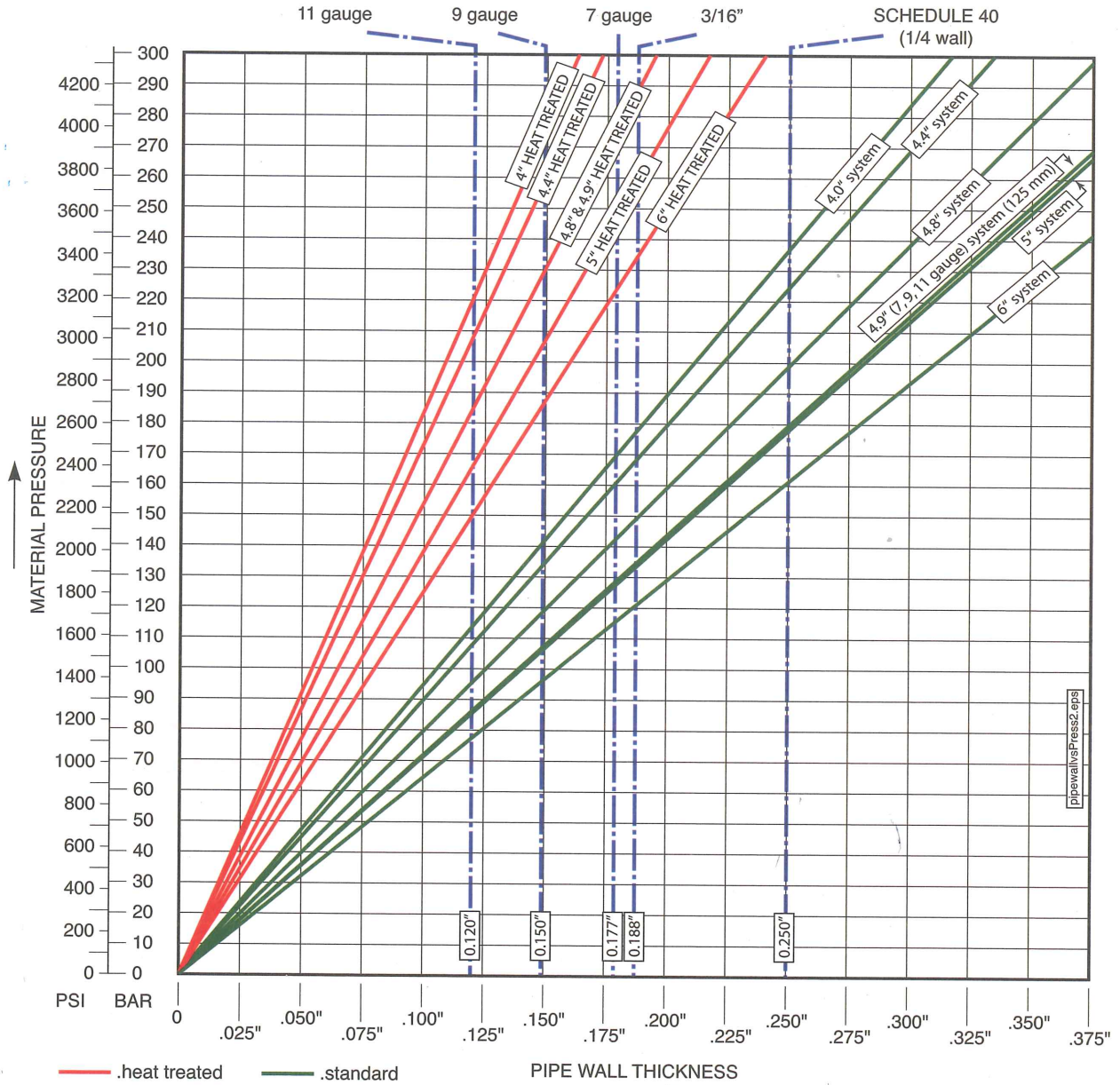

1. This chart assumes a safety factor of 2:1. Higher safety factors may be required in some circumstances.
2. Wear reduces wall thickness. Thickness must be checked on a regular basis.
3. Pressures may be limited even more by clamp style or pipe end used.
4. The chart is based on 62,000 PSI tensile strength. Heat-treated calculations are based on 120,000 PSI tensile strength.
5. The chart is for pressure calculations ONLY. There is no allowance for mechanical forces other than pressure, and thicker walls may be needed for mechanical strength because of support or restraint considerations.
6. The chart does not take into account metal fatigue caused by pressure cycles.

**Note!** This chart is intended as a guide for concrete pumping applications and is subject to the notes, assumptions, and conditions listed above. Any other use of this chart is not recommended.

This chart does not apply to double-wall pipe. Double-wall pipe can be checked by inspecting the inside of the pipe. If the insert is intact, the pipe is okay. If the insert is worn through, the pipe must be replaced. Contact your pipe supplier for the pressure capacity of your double-wall pipe.

## IX. Glossary Of Terms

### **Accumulator**

A hydraulic device that stores fluid power energy in much the same way that a battery stores electrical energy. Because an accumulator will store energy, it **MUST** be drained and depressurized before work begins on an accumulator-equipped actuator or hydraulic system.

### **Agitator**

A device that sits in the concrete hopper to keep concrete moving, preventing it from setting. It is typically a rotating shaft to which several paddles have been mounted. *See Also:* Hopper Grate

### **ASME B30.27**

A safety standard for material placement systems (concrete pumps and material placement conveyors) that has been accepted by ANSI as an American National Standard.

### **Blanking Plate**

Also known as a blanking plug or end cap. Its purpose is to prevent material from falling out of the delivery system when moving a boom with a full pipeline over personnel or property.

### **Blockage**

Simply put, if the pump is pushing and concrete fails to come out at the point of discharge, it is called a blockage. Blockages can be removed with pump pressure, by rocking the pump between forward and reverse, or some other remedial measure. If the blockage cannot be removed in such a manner, it's called a plug. *See Also:* Plug, Rock Jam. The causes of blockages are detailed in Section 6.12 of this manual. In all cases, blockages create a hazard by causing high concrete pressure, combined with the sometimes uncoordinated efforts of untrained workmen to remedy the problem.

### **Bulk Density**

The mass of a substance per volume. For example, one cubic foot of air weighs much less than one cubic foot of water. One cubic foot of lightweight concrete weighs less than one cubic foot of steel-entrained concrete. We could say that steel-entrained concrete has a higher bulk density than lightweight concrete. All calculations for the operation manuals and specifications of concrete pumps are based upon 150 pounds per cubic foot, which is the approximate mass of hard rock (normal) concrete.

### **Certified Operator**

An operator that has been issued a certification card by the American Concrete Pumping Association. There are several classes of certification, each relating to a different category of pump. For an operator to become certified, he (she) must: pass the written tests regarding operation, setup, and cleanout for each category of pump; pass the safety rules test which is common to all certification categories; meet the experience requirements set forth for each category; and maintain a safe and clean driving record. The certification card only certifies that the operator has passed a written test administered by an ACPA certification proctor and does not attest to their ability to operate a concrete pump. *See Also:* Qualified Person, Qualified Operator.

### **Concrete Delivery Hose**

A flexible concrete hose that has two end couplings.

### **Concrete Pressure**

The force per square area that is exerted on the concrete. The concrete pressure will always be a ratio in direct proportion to the hydraulic oil pressure on the concrete pump circuit. *See Also:* Maximum Pressure



## **Decibels**

One tenth of a bel. Abbreviated dB. It is a measurement of sound volume. As it applies to concrete pumps, it is a measurement of the sound pressure level one meter away from a noise source. O.S.H.A. has developed guidelines for time limits on exposure to sound at different volume levels. The chart can be found on page 15 of this manual.

## **Drive Engine**

The primary source of power for a hydraulic system. Typically, the word "engine" denotes an internal combustion device, whereas the word "motor" denotes an electrical device.

## **End Hose**

A flexible concrete hose that has one end coupling.

## **Foreign Material**

Material that was never intended to be pumped, which ends up in the concrete hopper. Examples of foreign material include: small animals; hammers; ready mix truck fins; unmixed clumps of cement; hardened concrete that breaks away from ready mix truck fins; and soda pop cans. These items could create a blockage if pumped.

## **Go-devil**

A plug made from a rubber composite, usually with several fins that expand to seal when pressure is applied. They are intended to be inserted in a steel delivery pipeline and pushed with water or compressed air for the purpose of cleaning the pipe. *See Also:* Sponge Ball

## **Guide**

An assistant brought in to help in backing up a truck or trailer, or to help in other circumstances where the driver cannot see enough to assure safety. *See Also:* Signaller

## **High Voltage**

For the purposes of this manual, anything over 28 volts is to be considered high voltage. In the U.S., electrically driven concrete pumps normally operate the motors at 480 volts AC (high voltage) and the controls at 24 volt DC (low voltage).

## **Hopper Grate**

A meshwork placed over the concrete hopper, typically made from steel bars. It serves the functions of keeping human body parts away from the agitator (when left in its proper position) and keeping large foreign objects from falling into the hopper, which could cause blockages if they were pumped.

## **Jacking the Outriggers**

Adjustment of the outriggers in the vertical direction.

## **Licensed Electrician**

A qualified electrician licensed by the state, county or municipality where the connections are to be made. In some locations electricians are not required to be licensed, and in these cases the work should still be carried out by competent professionals. Under no circumstances should high-voltage connections be made by a concrete pump operator or related personnel.

## **Maintenance**

All procedures for service, inspection, and repair of concrete pumps and related equipment and devices. Maintenance and inspection are methods of *maintaining* the desired state of the equipment. Repair is the method of *restoring* the desired state of the equipment.

## **Maximum Pressure**

When talking about a hydraulic system, maximum pressure refers to the highest pressure that can be achieved with the settings of the circuit relief valves. When discussing concrete output, maximum pressure refers to the pressure that will be developed if the hydraulic system pressure

# SAFETY MANUAL

reaches the relief valve setting. Concrete pressure is the force at which the differential cylinders are moving, divided by the cross sectional area of the concrete cylinder. Maximum concrete pressure, then, is developed when the differential cylinders are moving with maximum force, which is determined by the hydraulic system relief valve setting. *See Also:* Concrete Pressure.

## Minimum Safety Distance

In this manual, the term “minimum safety distance” refers to the closest distance that you are allowed to approach an object, electrical wires, etc. and still leave room for errors in human judgement or machine malfunction. With electrical wires in the U.S., this distance is 20 feet from the wires (50 feet above 350 Kv), as recommended by the American Concrete Pumping Association. This distance may have other values in different locations. It is up to the operator to know the value for the place of operation.

## Operational Area

The area around a working piece of equipment or point of discharge where hazards can be encountered due to the nature of the machinery or process in use.

## O.S.H.A.

Occupational Safety and Health Administration. A branch of the United States federal government that deals with job safety. It establishes and enforces safety regulations for industry and business. Among the areas over which it has authority are construction job sites and work shops.

## Personal Protective Equipment (P.P.E. or just PPE)

Things you can wear to protect yourself from potential dangers in a concrete placing environment. Examples are:

- Snug-fitting work clothes
- Steel-toed work boots
- Lime-resistant gloves
- Safety glasses
- Ear muffs or ear plugs
- Rubber boots when you have to stand in concrete
- Hard hat
- Breathing mask when working with cement dust

## Plug

A plug is a blockage that cannot be removed with the pump pressure, or by other remedial measures. A plug must be removed manually. *See Also:* Blockage.

## Point of Discharge

Also known as the point of placement. The location of concrete expulsion from a delivery system. This can be the point of placement (the actual form that is being filled with concrete) or the cleanout area after completion of the job.

## Pour

Used by the concrete pumping industry and in this manual as a noun. It is the specific job for the pump during any given time period. (e.g. “We’ll grab lunch right after the pour.”)

## Qualified Person

As used in this *Safety Manual*, a *qualified person* is defined as: a person who, by possession of a recognized degree of certificate of professional standing, or who by extensive knowledge, training, and experience, has successfully demonstrated the ability to solve or resolve problems relating to the subject matter and work. Other qualified persons may include master mechanics and after-sales service technicians of the manufacturer. *See Also:* Certified Operator



## Qualified Operator

Operators shall be considered qualified when they have completed a program of training and supervised operation of concrete pumps and have passed a practical operating examination of their ability to operate a specific model and type of equipment as well as their understanding of the controls and operating procedures. Furthermore, the operator must meet the knowledge and physical requirement sections of the concrete pumping safety standard.

## Qualified Personnel

A generic term used to describe a person who is qualified in the area of application. For example, having your boom repairs inspected by “qualified personnel” before use would refer to inspection by a certified welder or certified welding inspector. Having repairs to your hydraulic system done by “qualified personnel” would refer to repairs made by qualified workshop personnel.

## Qualified Workshop Personnel

An individual who:

- has reached the age of 18 years,
- is physically and mentally capable,
- has been trained in proper repair, maintenance, and inspection procedures plus the pertinent safety rules for concrete pumps and related equipment,
- has demonstrated their capabilities to their company in regards to the above mentioned procedures and rules, and
- can be expected to perform these duties, as assigned, in a reliable manner.

## Rock Jam

A specific type of blockage caused when the cement and fines of the concrete are not present in sufficient quantity to fully coat the larger aggregates and the walls of the delivery system. In these cases, the rock (larger aggregates of the mix) will form a wedge inside of the pipe. Resistance to movement then becomes overpowering and the concrete stops. *See Also:* Blockage.

## Separate Pipeline

A pipeline that is laid between the concrete pump and the point of discharge, other than the placing boom pipeline.

## Shutoff Valve

In hydraulics: a valve with the ability to stop the flow or pressure of hydraulic oil. It must be able to withstand the maximum pressure of the hydraulic circuit that it controls.

In concrete: A manually or hydraulically operated valve that will prevent the flow of concrete in either direction. The shutoff valve must be able to withstand the maximum pressure on the concrete of which the pump is capable of exerting.

## Signalperson

A person positioned at a vantage point where both the point of discharge and the pump operator can be seen and who relays operational signals to the operator.

## Soil Pressure

The force per square area that is exerted on the ground by the outrigger legs. The amount of pressure that the soil will support varies with the composition and compaction of the soil. To make a determination on the stability of the soil.

## Sponge Ball

A medium to hard sponge formed into a sphere and used to clean the inside of delivery pipelines. *See Also:* Go-devil

# SAFETY MANUAL

## **Spotter**

A person positioned at a vantage point where the distance between a hazard and the pump can be clearly seen and evaluated and the pump operator can be alerted if a predetermined safety distance is compromised. *See Also:* Guide

## **Sucking Back**

The act of putting the concrete pump into the reverse mode for any of several reasons.

## **Thrust Block**

Also known as a “dead man”. This is a large block of poured concrete, usually with one or more sweep elbows cast inside, placed at the bottom of a vertical run for the purpose of supporting the weight of the vertical run and for lateral stabilization of the pipeline. It stabilizes and supports the vertical run by virtue of its enormous mass (normally one cubic yard or larger).

## **Towing Vehicle**

In this manual, *Towing Vehicle* applies only to vehicles that tow trailer-mounted concrete pumps. It is the vehicle that you will use to tow the trailer on the road, on the job site, or in the yard. See the safety rules regarding this subject on page 8 of this *Safety Manual*.

## **Transport Position**

This relates to the position of the machinery when you will be driving or towing the unit. For example, the travel position of the engine hood is the position of the hood when it is completely lowered and latched into place.

## **Unauthorized**

Without authority, without permission. Examples: Unauthorized operation of the boom could be operation by a passer-by, unauthorized repairs to the boom could be repairs designed without the manufacturer’s knowledge.

## **Unintentional Movement**

Movement of the pump, boom or related equipment without a specific intentional command by the operator. An example of an unintentional movement would be if an operator fell while walking with the remote control box and accidentally hit a joystick, causing a boom movement.

## **Vertical Run**

Sections of concrete delivery pipeline that are running in an up (or down) direction. Vertical runs have very specific procedures and rules for installation, support, cleaning, and inspection. Concrete pumping personnel should, therefore, have specific training in these procedures and rules before attempting to use them in a job setting.

## **Water Jet**

The actual stream of water that comes out of the end of a water hose or pressure washer. This is the only part of the water system that needs to go into the hopper, concrete valve, or water box for cleaning.

## X. Recommended ACPA Hand Signals

The American Concrete Pumping Association (ACPA) recommends using the following hand signals as standard procedure.

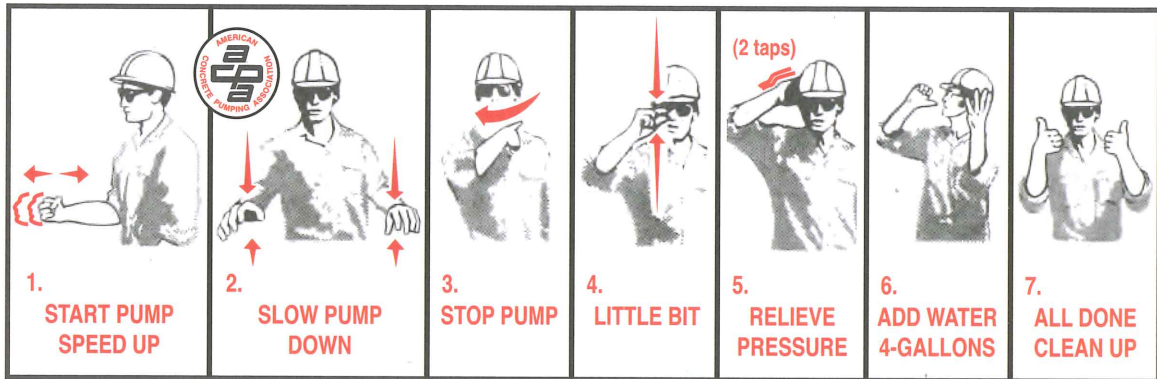

ACPAhandsgsmallline2.eps

## XI. Bibliography

Further information regarding concrete pumping is available from the sources listed below. Information for this book was gathered from several different sources, including the following books:

PUMPING CONCRETE AND CONCRETE PUMPS © F. W. Schwing, GmbH

CONCRETE PUMP OPERATOR'S GUIDE TO SAFETY © British Concrete Pumping Association

The MANUAL and ADVISORY SAFETY CODE of PRACTICE for CONCRETE PUMPING © British Concrete Pumping Association

SAFETY STANDARD FOR CONCRETE PUMPS, PLACING BOOMS, AND DELIVERY SYSTEM by the Concrete Pump Manufacturers Bureau

Additional technical information and/or graphic were supplied by:

Construction Forms, Inc.

The American Concrete Pumping Association

Some cartoons were scanned from the book CONCRETE PUMP OPERATOR'S GUIDE TO SAFETY © British Concrete Pumping Association. Used by Permission.

# SAFETY MANUAL



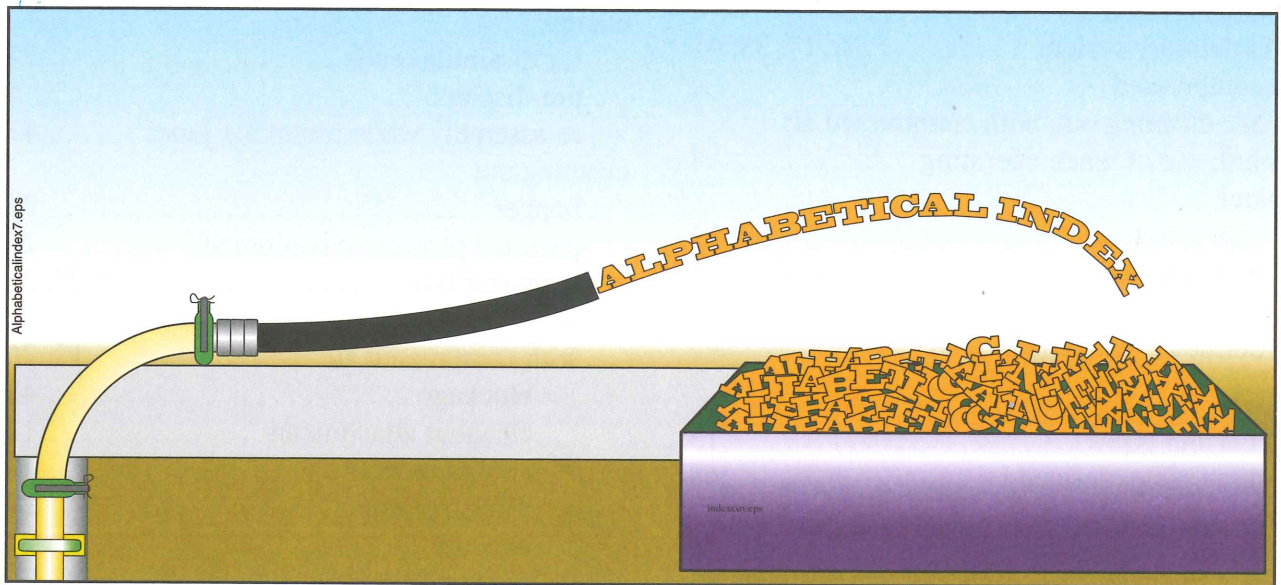

## Alphabetical Index

**A**

- accidents
  - causes of .....5, 9
- accumulator
  - changing max. pressure settings .....32
  - defined .....48
  - maintenance .....33, 34
- ACPA recommended hand signals .....44
- agitator, defined .....48
- air in delivery system .....16, 17, 38, 41
- air, compressed
  - See* cleaning out, with compressed air
- alcohol, use of when operating .....4
- apparel
  - appropriate .....2, 14
  - inappropriate .....2
- ASME B30.27
  - defined .....48

**B**

- ball catcher types .....13
- blanking plate, defined .....48
- blockage
  - before opening pipeline .....18, 19
  - clearing with compressed air ....19, 30, 42
  - concrete segregation .....18
  - defined .....48
  - foreign matter .....17, 36
  - inadequate pump .....17
  - inexperienced placing crew .....18
  - kinked hose .....19
  - operator error .....17
  - pipe deficiencies .....17
  - procedure to remove .....18
  - safe removal of .....18, 19, 38, 42
  - setting of concrete .....17
  - unpumpable mix .....17
- blowing out
  - See* cleaning out, with compressed air
- blowout head
  - See* cleanout accessories, blowout head
- boom
  - See* placing boom

- bulk density, defined .....48

**C**

- catcher, types of .....13
- caution, defined .....2
- certified operator, defined .....48
- checks
  - pre-dispatch .....5, 6
- children, dangers to .....12
- clamps
  - for dissimilar ends .....32
  - pre-dispatch .....5
  - re-assembly when removing pipes .....42
- cleaning out
  - hopper .....24
  - personal protective equipment .....24
  - the water box .....24, 25
  - water box .....25
  - with compressed air .....12, 26
    - blockage .....42
    - cleanout attachments .....12
    - communications .....29
    - discharge area .....29
    - experts .....26
    - near personnel .....27, 30
    - need for 2 people .....26
    - outlet positioning .....27
    - relieving air pressure .....26
    - shutoff valve .....28
    - through hose .....26, 27
    - through short pipe .....26, 27
    - trapped air .....28
    - vertical pipelines .....12, 29, 30
    - when to stop .....28
  - with water .....25, 26
- cleanout accessories
  - blowout head .....5, 12, 26
    - pre-dispatch .....5
    - use .....12, 27, 29
  - catcher .....26
    - pre-dispatch .....5
    - size .....5, 12
    - types .....13
    - use .....12, 27
- compressed air
  - attachments .....4, 12, 26, 27

hose	5, 12	expert	50
go-devil		foreign material	49
defined	49	go-devil	49
size	27	guide	49
use	27, 29	high voltage	49
sponge ball	5, 12, 26	hopper grate	49
defined	51	jacking the outriggers	49
size	5, 12, 27	licensed electrician	49
use	27, 29	maintenance	49
clothes, appropriate	2	maximum pressure	49
compressed air		minimum safety distance	50
<i>See</i> cleaning out, with compressed air		O.S.H.A.	50
concrete		operational area	50
unpumpable mix	17	Personal Protective Equipment	50
concrete delivery hose	9	point of discharge	50
concrete delivery hose, defined	9, 48	pour	50
concrete pressure, defined	48	qualified operator	14
concrete valve		qualified personnel	51
danger	21, 23, 39	qualified workshop personnel	51
couplings	32	rock jam	51
grooved (Victaulic), explained	46	safety alert symbol	2
Heavy-Duty, explained	46	separate pipeline	51
male/female O-ring type, explained	46	shutoff valve	51
metric, explained	46	signal word	2
<b>D</b>		signalperson	51
danger, defined	2	soil pressure	51
dead man,		sponge ball	51
<i>See</i> thrust block		spotter	52
decals		sucking back	52
safety	31	thrust block	52
decibel, defined	49	towing vehicle	52
definition		transport position	52
accumulator	48	unauthorized	52
agitator	48	unintentional movement	52
blanking plate	48	vertical run	52
blockage	48	warning	2
bulk density	48	water jet	52
caution	2	delivery system	
certified operator	48	air in line	16, 17, 38, 41
concrete delivery hose	48	cleaning with compressed air	12, 26
concrete pressure	48	cleaning with water	25
danger	2	damaged	10
decibel	49	gaskets	
drive engine	49	pre-dispatch	5
end hose	49	reassembly when removing pipe	42



- handling .....38, 43
- hose
  - inspection .....4
  - kinked .....19
  - pre-dispatch .....5
- inspection on the job .....10
- maximum pressure .....4, 9, 32
- minimum wall thickness .....4, 9, 10, 31
- pipe
  - ends .....32, 46
  - inspection .....4
  - pre-dispatch .....5
- repair of bad hose and pipe .....32
- sizing diameter .....10
- suspended sections .....10
- tapping for ball location .....26
- usable condition .....10
- vertical runs .....10
  - blowing out .....29
  - shutoff valve .....12, 29, 30
  - thrust block .....11
- drive engine, defined .....49
- driving
  - safety devices .....7, 8
  - stopping distance .....8
  - windshield and mirrors .....7
  - with concrete in the hopper .....8
- drugs .....4
- E**
  - electrical components
    - cautions .....33
  - electrically driven units
    - disconnect box .....9
    - maintenance .....33
    - power supply responsibility .....9
  - emergency stop (E-stop) .....7, 21, 35
  - end hose .....9
  - end hose, defined .....9, 49
  - expert, defined .....50
- F**
  - falling, prevention .....16, 33, 37, 43
  - fishtailing, cause .....8
  - foreign material, defined .....49
- G**
  - gasoline and diesel fuel
    - as cleaning solvents .....34
  - glossary of terms .....48
  - go-devil .....5
    - catcher .....5, 13
    - defined .....49
    - size .....27
    - use .....29
  - grate
    - water box .....20
  - guards, removal of
    - for inspection .....31
    - for servicing .....32
  - guide
    - defined .....49
- H**
  - hand signals .....11, 21
    - ACPA recommended .....44
    - who should give .....44
  - high voltage
    - defined .....49
  - hopper
    - danger around .....21, 23, 24, 36, 39
  - hopper grate, defined .....49
  - hose
    - inspection .....4
    - kinked .....19
    - maximum pressure .....4
    - pre-dispatch .....5
- I**
  - inspection
    - concrete pump circuits .....31
    - delivery system .....31
    - placing boom



# SAFETY MANUAL

ALPHABETICAL INDEX

- daily ..... 31
- safety devices ..... 31
- service bulletins ..... 31
- J**
- jacking the outriggers, defined ..... 49
- K**
- kinked hose, *See* blockages
- L**
- laborers
  - alone at the pump ..... 20, 35
  - assigned to the pump ..... 20, 35
  - E-stop location knowledge ..... 20, 35
  - handling delivery system ..... 38, 43
  - notifying operator ..... 36
  - personal protective equipment ..... 35
- licensed electrician, defined ..... 49
- lights ..... 7
- lockout, tagout ..... 21, 33
- loose items
  - securing for travel ..... 7
- M**
- maintenance
  - changing maximum pressure settings ... 32
  - components, damaged ..... 32
  - cranes and hoists, use of ..... 33
  - defined ..... 49
  - for safety ..... 32
  - gas or diesel as cleaning solvent ..... 34
  - hidden areas ..... 33
  - of electrically driven units ..... 33
  - of spring- or gas-loaded devices ..... 33
  - oil, hot ..... 33
  - operation of boom ..... 33
  - removal of safety devices ..... 32
  - repairs
    - by qualified personnel ..... 33
    - of hydraulic hose and pipe ..... 32
    - of pressurized hydraulics ..... 34
  - repairs, incorrect ..... 33
  - safety of workers ..... 34
  - structural modifications, unauthorized ... 32
  - tools, correct ..... 34
- maximum pressure, defined ..... 49
- medications, cautions ..... 4
- minimum safety distance, defined ..... 50
- N**
- noise exposure chart ..... 15
- O**
- O.S.H.A. .... 9
  - defined ..... 50
  - noise exposure chart ..... 15
- oil
  - spills ..... 32
- oilers, *See* laborers
- operation
  - danger to children ..... 12
  - discharge point ..... 11, 21
  - for servicing ..... 33
  - noise ..... 15
  - noise exposure chart ..... 15
  - personal protective equipment ..... 14
  - problems with equipment ..... 18, 31
  - unfamiliar machines ..... 7
  - warnings ..... 4
- operation manual ..... 4, 7, 31, 32, 33
- operational area
  - defined ..... 50
- operator
  - certification ..... 48
  - qualified, defined ..... 14
- outrigger jacking, defined ..... 49
- outriggers
  - pinning ..... 7
- P**
- personal problems, at work ..... 4
- Personal Protective Equipment (P.P.E.) 2, 7, 14, 18, ..... 24, 35
  - defined ..... 50
  - for laborers ..... 35
  - for placing crew ..... 41
  - securing for travel ..... 7
- pipe
  - ends ..... 32
  - inspection ..... 4
  - opening when pressurized ..... 18, 42
  - pre-dispatch ..... 5

- pressurized .....42
- placing boom
  - as hoist .....33
  - discharge point .....11, 21
  - unintentional movement .....21
- placing crew
  - dangerous areas .....42
  - dealing with blockages .....38, 42
  - handling hose and system .....42
  - hazards
    - compressed air in pipeline .....42
    - falling .....16, 33, 37, 43
    - hose kinking .....43
    - pressurized pipes .....43
  - personal protective equipment .....41
  - safety rules .....41
- point of discharge, defined .....50
- pour, defined .....50
- PPE, *See* Personal Protective Equipment
- Q**
- qualified operator, defined .....51
- qualified personnel, defined .....51
- qualified workshop personnel, defined .....51
- R**
- ready mix truck
  - backing .....15, 36
  - driver
    - cleaning out in the hopper .....36
    - what to teach them .....20
    - when to begin dumping .....36
  - foreign material from .....36
  - signalling the driver .....15, 36
- remote control
  - plugging and unplugging .....21
- rock jam, defined .....51
- S**
- safety alert symbol, defined .....2
- separate pipeline, defined .....51
- service bulletins .....31
- setup
  - ready mix truck approach .....9
  - traffic .....9
  - unsafe .....9
- shutoff valve
  - pressure requirements .....28
- shutoff valve, defined .....51
- signal word, defined .....2
- signalperson
  - use .....11, 21, 44
- signalperson, defined .....51
- signalperson, how many may become .....44
- sleep, importance of .....2
- soil pressure, defined .....51
- sponge ball
  - catcher .....13
  - defined .....51
  - size .....27
  - use .....29
- spotter, defined .....52
- sucking back, defined .....52
- symbols
  - caution .....2
  - danger .....2
  - warning .....2
- T**
- thrust block, defined .....52
- towing
  - backing up .....8
  - knowledge of the laws .....8
  - loss of control .....8
  - stopping distance .....8
  - trailer mounted pumps .....8
  - trailer-mounted pumps .....8
- towing vehicle, defined .....52
- transport position, defined .....52
- U**
- ultrasonic thickness tester .....31
- unauthorized, defined .....52
- unintentional movement, defined .....52
- V**
- vertical pipeline
  - See* delivery system, vertical runs
- vertical run, defined .....52
- Victaulic, *See* couplings, grooved (Victaulic),

explained

## W

warning, defined ..... 2

water box

    checking while pumping ..... 20

    danger ..... 21, 23, 24, 25, 39

water jet, defined ..... 52

weather conditions

    considerations ..... 6

welding

    current arcing damage ..... 32

    on electrical components ..... 33

weld-on ends, types ..... 46

workers

    alone at the pump ..... 20, 35

    assigned to the pump ..... 20, 35

    e-stop location knowledge ..... 20, 35

Information contained in this Safety Manual is not intended to supercede the manufacturer's recommendations or company policies.



606 Enterprise Drive  
Lewis Center, OH 43035  
614 431 5618  
[www.concretepumpers.com](http://www.concretepumpers.com)