



A-SERIES TECHNICAL MANUALS

Operations, Maintenance, Schematics, Parts, Safety



OPERATIONS/ MAINTENANCE

- Introduction
- Warranty
- Safety
- Operation
- Main Controls
- Priming
- Pumping
- Clean-up
- Maintenance
- Check-List

SCHEMATICS/ PARTS LISTS

- Pumping Train Group
- Power Train Group
- Electrical Group
- Controls
- Frame Installation
- Available Options

SAFETY MANUAL AMERICAN CONCRETE PUMPING ASSOCIATION



- Introduction
- General Safety Rules
- Appendix



OPERATION and MAINTENANCE

13822 Oaks Avenue
Chino, CA 91710
reedpumps.com
(909) 287 - 2100

INTRODUCTION 2

WARRANTY 3

 WARRANTY CLAIM FORM..... 4

SAFETY 5

 SAFETY ALERT SYMBOLS AND SIGNAL WORDS 5

 LOCKOUT / TAGOUT 5

 GENERAL SAFETY GUIDELINES 6

 SAFETY DECALS 7

OPERATION 14

 OPERATOR QUALIFICATIONS 14

 PRODUCT DESCRIPTION 15

 HYDRAULIC SYSTEM DESCRIPTION 16

 CONTROLS..... 23

 ERROR CODES 24

 PRIMING 30

 PUMPING CONCRETE 31

 JOBSITE CLEANUP 33

MAINTENANCE 34

 RECOMMENDED MAINTENANCE PRACTICES 34

 GENERAL MAINTENANCE AREAS 35

 LUBRICATION..... 37

 COMPONENT REPLACEMENT 45

 S-TUBE, WEAR RING, AND WEAR PLATE 45

 S-TUBE ADJUSTMENT 49

 PISTON CUP AND GUIDE BAND REMOVAL/REPLACEMENT 50

 PUMP MAINTENANCE SCHEDULE AND CHECKLISTS 53

REV	DATE	DESCRIPTION	NAME
*	4/17/2017	INITIAL	J.SLACK



INTRODUCTION

This manual introduces the warranty policy, safe operation, safe maintenance, parts, and other aspects of the concrete pump.

Reading and understanding this operation manual will help maximize performance and reliability, and help minimize dangers, improper operation, and repair costs. Contact REED Customer Service for additional replacement manuals.

All safety guidelines, product descriptions, illustrations, and specifications found throughout this manual were in effect at the time the manual was released for printing. It should be noted; REED RESERVES THE RIGHT TO MAKE CHANGES IN DESIGN OR TO MAKE ADDITIONS TO OR IMPROVEMENTS IN THE PRODUCT WITHOUT IMPOSING ANY OBLIGATIONS UPON ITSELF TO INSTALL THEM ON PRODUCTS PREVIOUSLY MANUFACTURED.

Everyone involved with the operation, maintenance, inspection, and repair of the concrete pump MUST READ and UNDERSTAND this manual and the accompanying Safety Manual.



WARRANTY

REED warrants each new A, B, and C Series Concrete Pump to be free of defects in material and workmanship under normal use and service for a period as follows:

A Series Pumps

- 1 year or 1200 pumping hours whichever occurs first

B and C Series Pumps

- “Hitch to Hopper” for 1 year or 1200 pumping hours, whichever occurs first
- All Structural Parts for 3 years

The warranty is issued **ONLY** to the **INITIAL USER**. The warranty period begins when the product is delivered to the initial user or when first put into service, whichever occurs first. Said warranty is void if the machine is subject to misuse, neglect, accident, and/or abuse.

REED's obligation under this warranty is limited to correcting without charge, at its factory, any parts or parts thereof which shall be returned to its factory, transportation prepaid and upon **REED**'s examination proves to have been originally defective. Correction of such defects by repair or replacement shall constitute fulfillment of all obligations to the initial user. This warranty does not include labor or transportation charges unless specifically identified and authorized in writing by **REED**. Nor does the warranty apply to any unit upon which repairs or unauthorized alterations have been made.

This warranty does not apply to normal maintenance service or to normal replacement of certain machine parts which are subject to normal wear (such as concrete cylinders and wear components, valve mechanisms, delivery systems, hopper grate, etc.) **REED** makes no warranty in respect to trade accessories or outside vendor components, such being subject to the warranties of their respective manufacturers.

THIS IS A LIMITED WARRANTY AND IS IN LIEU OF ANY OTHER WARRANTIES, EXPRESSED OR IMPLIED, INCLUDING ANY WARRANTY OF MERCHANTABILITY OF FITNESS FOR A PARTICULAR PURPOSE. In no event shall **REED** be made liable for incidental, general or consequential damage, loss or any expense directly or indirectly related and resulting from use or lack of use caused by delay in delivery, parts failure, or any other causes associated with the product use. No person, firm or corporation is authorized to assume for **REED** any other liability in connection with the sale of **REED** products.

Effective April 2010



OPERATION and MAINTENANCE

13822 Oaks Avenue
Chino, CA 91710
reedpumps.com
(909) 287 - 2100

WARRANTY CLAIM FORM					
Claim Number:			Date:		
Distributor Account Number:			End User Account Number:		
Distributor:			End User:		
Address:			Address:		
City:	State:	Zip:	City:	State:	Zip:
Phone ()			Phone ()		
Pump Model: _____			In Service Date: _____		
Pump Serial Number: _____			Hours of Operation: _____		
			Failure Date: _____		
			Repair Date: _____		
Do not send part(s) until requested by REED or until claim is approved. All parts requested to be returned must have a Return Authorization Number provided by REED and shipping freight prepaid. Parts must ship within 30 days from REED request.					
Return Authorization Number:			Ship Date:		
Part Number	Description	Qty	Unit Price	Total Price	Replacement Part Invoice No.
Failure Description and Cause: _____					
REED Comments: _____					
Claim Value Approved:\$ _____			Claim Value Denied:\$ _____		
REED Print Name, Sign, and Date: _____					
Dealer Print Name, Sign, and Date: _____					

SAFETY

Everyone involved with the operation, maintenance, inspection, and repair of the concrete pump **MUST READ** and **UNDERSTAND** this manual and the accompanying Safety Manual.

SAFETY ALERT SYMBOLS AND SIGNAL WORDS

The following safety alert symbols, signals, and explanations are intended to warn the operator of hazardous and potentially hazardous situations.

The triangle with the exclamation point inside is used to alert the operator to an important safety point, and is called a safety alert symbol. One of the following signal words will appear after the safety alert symbol:



If the safety alert symbol is followed by the signal word **DANGER**, the safety alert symbol indicates a hazardous situation which, if not avoided, **WILL** lead to death or serious injury.

If the safety alert symbol is followed by the signal word **WARNING**, the safety alert symbol indicates a potentially hazardous situation which, if not avoided, **COULD** result in death or serious injury.

If the safety alert symbol is followed by the signal word **CAUTION**, the safety alert symbol indicates a potentially hazardous situation which, if not avoided, **COULD** result in minor to moderate injury.

The signal word **CAUTION**, but without safety alert symbol means the safety symbol alert addresses a hazard which, if not avoided, **COULD** cause damage to equipment or property.

LOCKOUT / TAGOUT

The Lockout/Tagout procedure applies to all **REED** concrete placing equipment. Before performing any maintenance and/or repair on equipment;

1. Unit must be OFF and the ignition key must be removed from the control panel or dash.
2. Key must be securely stored in toolbox or with operator performing maintenance.
3. Signage must be posted to indicate machine is currently under Lockout/Tagout.

The following symbol is a reminder to Lock Out and Tag Out equipment before working on equipment.



GENERAL SAFETY GUIDELINES



Use Only Qualified, Experienced, and Trained Personnel
Wearing Protective Equipment At All Times



For Safe Use, Maintenance, Inspection, and Repair,
Only Operate, Maintain, Inspect, and Repair
In Accordance With This Operation Manual and the Safety Manual



Performance and Safety Features Must Never Be Altered, Disconnected, or Removed



Contact **REED** Technical Support and Service When Assistance Is Required



SAFETY DECALS

Decals and placement of decals are standardized by the Concrete Pump Manufacturers Association (CPMA) for your protection. They are placed at appropriate areas on the concrete pump to be constant warnings of dangers. Know and adhere to the information they provide. Contact **REED** Customer Service for complimentary replacements of safety decals, shipping charges may apply.

DECALS PLACED NEAR CONTROL BOX AREA

	<p style="text-align: center;">⚠ WARNING</p> <p>Do not operate this machine without training. Understand the warnings in safety manuals and on decals.</p> <p style="text-align: center;">⚠ ADVERTENCIA</p> <p>No use esta maquinaria sin estar capacitado. Entienda las advertencias de los manuales de seguridad y de las calcomanías.</p>
Do not paint over this label/No pintar encima de ésta etiqueta	
800925	

IMPORTANT	IMPORTANTE
<p>You can order additional operation manuals, spare parts books, safety manuals and decal sets by contacting us at: REED Manufacturing 1-(888)-779-7333 7:00 AM to 5:00 PM Pacific Time Monday through Friday</p>	<p>Usted puede solicitar manuales de operacion, catalogos de refacciones, manuales de seguridad y juegos de calcomanias adicionales contactando a: REED Manufacturing 1-(888)-779-7333 DE 7:00 AM a 5:00 PM Hora Pacifico LUNES A VIERNES</p>
Do not paint over this label/No pintar encima de ésta etiqueta	
803226	



OPERATION and MAINTENANCE



13822 Oaks Avenue
Chino, CA 91710
reedpumps.com
(909) 287 - 2100

⚠ WARNING			SAFETY INSTRUCTIONS	
			<ol style="list-style-type: none"> 1. Relieve system pressure before opening any system or coupling. 2. Regularly inspect system condition and wall thickness. 3. Wear reduces system burst pressure. 4. Use recommended clean out procedures - consult manufacturer. 5. Use retaining pins in delivery system snap couplings. 	
<ul style="list-style-type: none"> • Stay clear of pressurized concrete placing system. • Wear eye protection. • Do not operate at pressures exceeding the rating of any piece of the material delivery system. 			INSTRUCCIONES DE SEGURIDAD	
⚠ ADVERTENCIA <ul style="list-style-type: none"> • Permanezca alejado del sistema de distribución de concreto presurizado. • Use protección para los ojos. • No opere a presiones mayores que las de la capacidad de cualquier pieza del sistema de descarga. 			<ol style="list-style-type: none"> 1. Alivie la presión del sistema ante de abrir un sistema o un acoplamiento. 2. Inspeccione periódicamente el estado del sistema y el espesor de las paredes. 3. El desgaste reduce la presión de rotura por estallido. 4. Use los procedimientos de limpieza recomendados, consulte con el fabricante. 5. Use los pasadores de retención en los acoplamientos de fijación a presión. 	

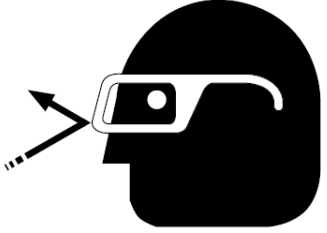
803237

ADVERTENCIA ⚠ WARNING		
		
Do not paint over this label/No pintar encima de ésta etiqueta		

800929A

INSTRUCCIONES DE SEGURIDAD				SAFETY INSTRUCTIONS		
 Recommended hand signals Señales de mano recomendadas						
						
1. START PUMP SPEED UP	2. SLOW PUMP DOWN	3. STOP PUMP	4. LITTLE BIT	5. RELIEVE PRESSURE (2 golpecitos) (2 taps)	6. ADD WATER 4-GALLONS	7. ALL DONE CLEAN UP
1. PRENDER LA BOMBA ACELERAR	2. BAJAR VELOCIDAD A LA BOMBA	3. PARAR LA BOMBA	4. UN POCO	5. ALIVIAR LA PRESIÓN	6. AÑADIR AGUA 4-GALONES	7. TERMINADO LIMPIAR

Do not paint over this label/No pintar encima de ésta etiqueta

803235

DECALS PLACED NEAR HOPPER GRATE AREA

⚠ WARNING



Do not paint over this label/No pintar encima de esta etiqueta

Keep hands out of hopper and valve assembly. See operation manual if access is required.

⚠ ADVERTENCIA

No meta las manos a la tolva o válvula. Consulte el manual de operación si necesita tener acceso.

800917

⚠ WARNING



Do not paint over this label/No pintar encima de esta etiqueta

Stay off hopper grates.

⚠ ADVERTENCIA

Manténgase alejado de la rejilla que cubren la tolva.

800918

⚠ WARNING



Do not paint over this label/No pintar encima de esta etiqueta

Cement dust is toxic. Use lung protection when exposed.

⚠ ADVERTENCIA

El polvo de cemento es tóxico. Use protección para los pulmones cuando se exponga.

803231



OPERATION and MAINTENANCE

13822 Oaks Avenue
Chino, CA 91710
reedpumps.com
(909) 287 - 2100

DECALS PLACED NEAR WATERBOX AREA

	 WARNING
	Keep hands out of waterbox. Stop motor if access is required. Keep guards in place.
	 ADVERTENCIA
	No meta las manos a la caja de agua. Pare el motor si necesita tener acceso. Mantenga las cubiertas cerradas.

Do not paint over this label/No pintar encima de ésta etiqueta 800916

DECALS PLACED NEAR OUTRIGGER CONTROL AREA

	 WARNING
	Clear area before activating outriggers.
	 ADVERTENCIA
	Despeje el área antes de activar los estabilizadores.

Do not paint over this label/No pintar encima de ésta etiqueta 800919



OPERATION and MAINTENANCE

13822 Oaks Avenue
Chino, CA 91710
reedpumps.com
(909) 287 - 2100

DECALS PLACED NEAR HOPPER OUTLET AREA

	⚠ WARNING
	Do not operate at pressures exceeding the rating of the entire material delivery system.
	⚠ ADVERTENCIA
	No utilizar a presiones que excedan la presión nominal de todo el material de la línea de entrega.
Do not paint over this label/No pintar encima de ésta etiqueta	
800921	

	⚠ WARNING
	Before opening a blocked pipeline, relieve pressure by reversing pump. See manual.
	⚠ ADVERTENCIA
	Alivie la presión antes de destapar una tubería bloqueada, invirtiendo para ello la bomba. Vea el manual.
Do not paint over this label/No pintar encima de ésta etiqueta	
800922	



OPERATION and MAINTENANCE

13822 Oaks Avenue
Chino, CA 91710
reedpumps.com
(909) 287 - 2100

DECALS PLACED ON SIDE PANEL AREA



⚠ WARNING
 This machine is remote controlled and may start at any time. Stop engine before servicing unit.

⚠ ADVERTENCIA
 Esta máquina funciona a control remoto y puede ponerse en marcha en cualquier momento. Apagar el motor antes de realizar el mantenimiento.

Do not paint over this label/No pintar encima de esta etiqueta

800924

⚠ WARNING

Do not touch hydraulic oil leaks. Get immediate medical attention if oil penetrates skin.

⚠ ADVERTENCIA

No toque las fugas de aceite hidráulico. Obtenga atención médica inmediata si el aceite penetra en la piel.

Do not paint over this label/No pintar encima de esta etiqueta

803225







OPERATION

OPERATOR QUALIFICATIONS

Everyone involved with the operation, maintenance, inspection, and repair of the concrete pump MUST READ and UNDERSTAND this operation manual and the accompanying Safety Manual.

The following are a few general warnings for operator qualifications outlined in the Safety Manual.



- Individuals who cannot read and understand this operation manual, Safety Manual, signs, warnings, notices, and operating instructions, in the language in which they are printed, must not be allowed to operate the concrete pump.
- Only qualified, experienced, and trained personnel may be allowed to operate the concrete pump.
- Operation, maintenance, inspections, and repair must only be made by qualified, experienced, and trained personnel.
- Obey all applicable local and government statutes and regulations applying to safe operation and towing of concrete pumps.



PRODUCT DESCRIPTION

The operation of the concrete pump encompasses the use of hydraulic and electrical systems. The concrete pump is designed to safely pump wet concrete through a delivery system of pipes and hoses within its published ratings and specifications.

Stability of the concrete pump during operation is provided by the outriggers and front jack. Controls for the outriggers are located on the sides of the concrete pump.

The pumping system employs a S-Tube design valve system. This system incorporates material cylinders linked to hydraulic cylinders that cycle alternately. With concrete material in the hopper and the pump operating, a material cylinder retracts, drawing material into the cylinder. At full retraction of the cylinder, a signal is sent to both the S-tube swing cylinder and the drive cylinder directional valves causing the s-tube to shift position to the fully loaded material cylinder and the drive cylinders to change direction. The concrete piston of the loaded cylinder then pushes the material through the s-tube and into the delivery lines. The shifting from one cylinder to the other cylinder takes place providing a continuous flow of material through the delivery piping system. The pump can be operated at the control panel or can be operated from the remote control.

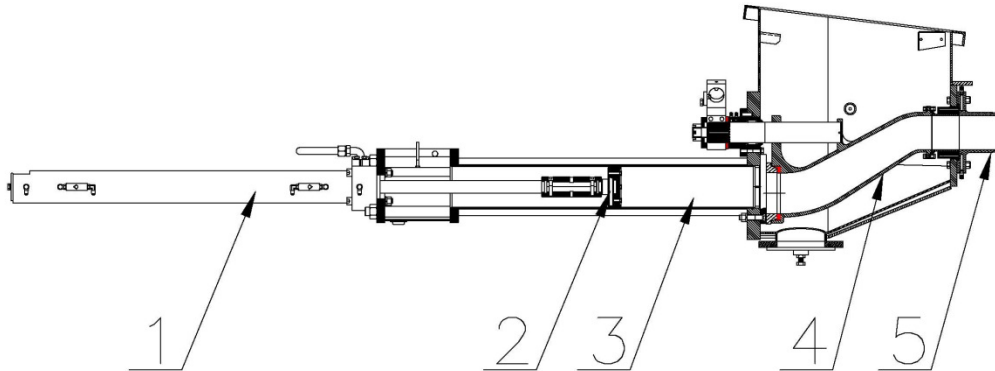

The hydraulic oil flow created by the hydraulic pump pushes the drive cylinder pistons inside the drive cylinders (1) alternately back and forth. Because the drive cylinders and concrete pistons (2) inside the concrete cylinders (3) are linked together, the pistons move synchronously.

When a drive cylinder retracts along with the concrete piston, concrete will be sucked from the hopper into the concrete cylinder. Simultaneously, the other drive cylinder and concrete piston are extended toward the hopper. The concrete piston will push concrete from the concrete cylinders through the S-Tube (4) and out to delivery system (5).

Next, the pump switches at the end of the stroke, causing the s-tube valve to shift to the other concrete cylinder which has sucked and filled the cylinder with concrete, starting the next cycle.

Reverse pumping links the concrete piston in the suction stroke and S-Tube valve to suck concrete from the s-tube instead of the hopper. As a result, the concrete piston pumps concrete into the hopper.

The power for operation of the concrete pump is provided by the engine, which drives the hydraulic pumps.

All functions for operation of the concrete pump can be accomplished from the local controls mounted



on the side of the unit. Optional hand-held cable or radio remotes enable the pump to be operated away from a remote distance.

HYDRAULIC SYSTEM DESCRIPTION

The hydraulic system of the concrete pump consists of three separate circuits and although integrated, each is designed to perform a particular function within the operation of the concrete pump. The three circuits utilized are:

- **Main Pump Circuit**
Controls operation of the hydraulic drive cylinders.
- **S-Tube Shift Circuit**
Controls operation of shifting the s-tube from one material cylinder to the other.
- **Auxiliary Circuit**
Controls the operation of the agitator and other auxiliary equipment.

For the purpose of making the operation of each circuit easier to understand, they are being described separately.

MAIN PUMP CIRCUIT

The main hydraulic pump is a variable displacement axial piston pump of swashplate design. The pistons run along the swashplate which is capable of being tilted. This tilting changes the angle of the swashplate and thus the stroke length of the pistons, which in turn varies the displacement of fluid. The larger the angle of the swashplate, the greater the flow of fluid. The angle of the swashplate is varied by the volume control that works in conjunction with the load sense feature of this pump.

The main hydraulic pump is driven directly by the engine or electric motor. When the engine is running, PUMP switch in the OFF position and the VOLUME control minimized, there is no demand placed on the pump. This is referred to as the pump being de-stroked, meaning, it is only producing a minimal amount of flow to enable the lubrication of the pump. This lubrication exists regardless of whether the engine is at idle or maximum RPM.

The main pump circuit is equipped with a manifold that is drilled and ported to accommodate the relief valve, check valve, flow control and the pilot operated directional valve. The cycle valve is a directional spool valve with electro hydraulic solenoid operation. Its purpose is to direct the flow of oil from the main hydraulic pump to one or the other hydraulic drive cylinders.

To energize the pump circuit, use the adjustable throttle control to set the engine speed at maximum RPM. Open the VOLUME control to any range from 0 to FULL. In so doing, the load sense is alerted to the demand and places the pump on stroke. The pump will now produce the flow in proportion to the amount by which the volume control has been opened. Since the PUMP switch is OFF, the flow from the hydraulic pump is fed to the main directional valve, thru the valve, and then returns to the hydraulic tank.



OPERATION and MAINTENANCE

13822 Oaks Avenue
Chino, CA 91710
reedpumps.com
(909) 287 - 2100

To energize the cycling circuit, the PUMP switch must be ON. When this is done, an electrical signal is generated which in turn energizes the coils of the main directional pilot valve and also activates the S-Tube directional valve.

The material pumping action is the result of the two material cylinders cycling on an alternate basis. This alternating cycling is controlled by an electrical signal that is generated by the proximity sensors located in the flush box at the end of each material cylinder's suction or retraction stroke.

As the piston coupler passes under the proximity sensor, it generates an electrical input signal that is sent to the logic controller, designed to control the alternating action of the material cylinders and to synchronize the movement of the s-tube. The output signal from the logic controller is used to energize the coils of the main directional pilot valve as well as that of the s-tube directional valve.

As protection to the main pump circuit against excessive pressure, a relief valve has been installed and set. Thus when the system pressure reaches the maximum factory settings, the relief valve opens directing the oil back to the tank.

MAIN PUMP CIRCUIT OPERATIONAL SEQUENCE

It can be noted in the schematic and the diagram below that the main pressure and flow is only directed to one side of the hydraulic drive cylinder. In this instance, it is directed to the head side or piston side of the double acting drive cylinder.

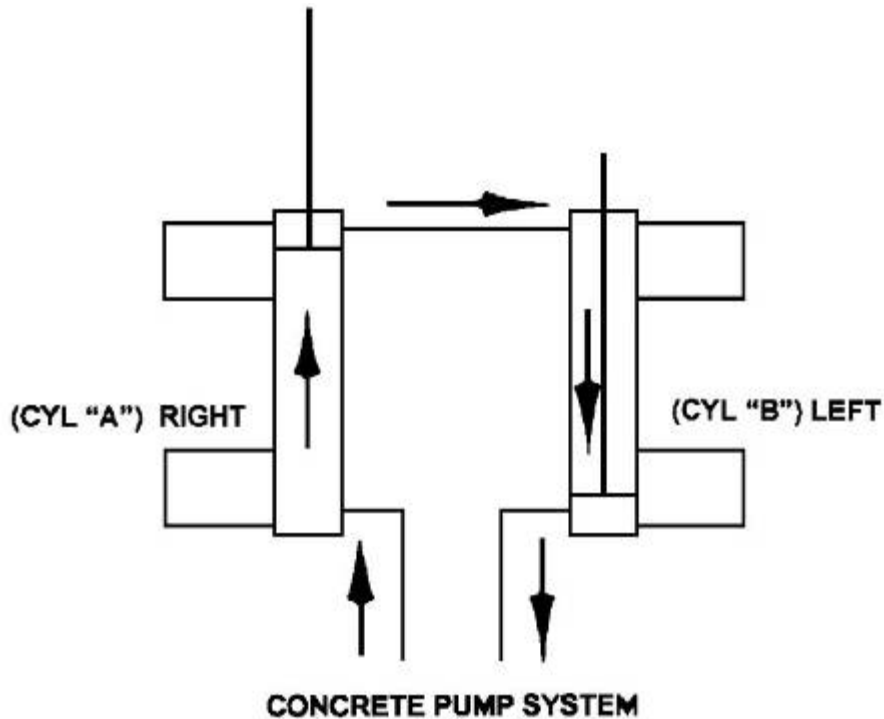

The hydraulic drive cylinders are identical. Because only one cylinder is pressurized at a time, a means is required to assist in the retraction of the opposite cylinder. This is accomplished by connecting the rod sides of the cylinders together, forming a slave loop. In so doing, the hydraulic fluid that exists in the rod side of the extending cylinder (CYL "A") is transferred to the rod side of the other cylinder (CYL "B") causing it to retract simultaneously. The oil in the head side of CYL "B" is then forced out as it retracts and free flows through the directional valve back to the hydraulic tank or system.

With this arrangement of connecting the two cylinders together, it is possible for various reasons, such as leakage around the piston seals, that more oil exists on the rod side of the cylinder than is required. When this condition exists, some hydraulic oil remains at the rod end of the cylinder being extended while the other cylinder is fully retracted. As a result, the cylinder will not completely extend and thus short strokes, which will also happen to the other cylinder on the next cycle.

This condition can be corrected by actuating and holding the STROKE CHANGE switch on the electrical control box until extending cylinder is fully extended. Hydraulically, this is accomplished by use of the check valves installed on both cylinders. By holding the STROKE CHANGE switch, you have interrupted the cycle and are forcing more oil into the head side of the extending cylinder. Since that cavity is full, pressure is built up in the rod side of the fully retracted cylinder, which unseats the head-side check valve and forces the excess oil out of the slave loop and back to the tank. Once the



extending cylinder has reached its full stroke, regular operation can continue.

Short stroking can also occur from incorrect proximity sensor location or leaking check valves.

S-TUBE CIRCUIT

Since there is only one outlet for the pumping material, a means is required to transfer the material from the material cylinder to the outlet and into the delivery line. To accomplish this, an s-tube is installed in the hopper. Since there are two material cylinders and one s-tube, the s-tube must be shifted from one material cylinder to the other, whichever one is loaded with the pumping material.

The s-tube shift hydraulic circuit is of the open center type, meaning that when the control valves are in the neutral position, the internal passages of the valves are open, allowing the hydraulic fluid to return to the tank. With the engine running the hydraulic pump is operating, producing a flow of oil which, with no control energized, will pass through the shift circuit on its way back to tank.

To meet the flow and pressure requirements of the shift circuit, one section of a tandem pump is used. Note: a single pump may be used if unit is not required for auxiliary equipment. The tandem hydraulic pump is of the gear pump design with a fixed displacement, meaning it is designed to constantly produce the same displacement at a pre-set maximum, depending on engine rpm. The tandem gear pump is directly connected to and driven through the main hydraulic pump. In addition to the hydraulic pump, the s-tube shift circuit consists of a manifold, an accumulator, solenoid valve cartridges, a solenoid directional valve, and 1 or 2 hydraulic shift cylinders. The following is offered to describe the function of each in the system.

S-TUBE CIRCUIT MANIFOLD

Like the main hydraulic circuit, the shift circuit is also equipped with a manifold block. It contains an unloader cartridge, relief cartridge, solenoid valve cartridges, directional valve (solenoid or pilot operated) and an s-tube shift selector ball valve. Each of these components is designed to perform a particular function in the swing circuit as explained in the following descriptions:

- **RELIEF CARTRIDGE**

This cartridge is used to divert the pump flow from going to the accumulator once its capacity has been reached, directing it to free flow back to tank. It becomes operational when the unloader cartridge setting has been reached, acting as a dump valve.

- **UNLOADER CARTRIDGE**

This pressure sensitive cartridge is used to protect the system from excessive pressure. It limits the amount of pressure being applied to the accumulator by hydraulically signaling the relief cartridge to open once the unloader setting has been reached. The unloader will also redirect the oil back to the accumulator when it senses a drop in system pressure, when the hydraulic cylinder shifts for example.

- **SOLENOID VALVE CARTRIDGE**

There are two (2) of these cartridges used in the circuit. These cartridges, which may be referred



to as dump valves, are designed into the circuit as SAFETY VALVES. Close-loop models utilize one (1) solenoid valve. Their purpose is to automatically relieve pressure from the shift circuit as commanded by the emergency stop circuit. At start up, the normally open cartridges are open to tank so the shift circuit can not build any pressure. When the emergency stop circuit is reset, an electrical signal is generated which energizes the solenoids, closing the cartridges and allowing the shift circuit to pressurize. When the emergency stop function is activated or the key switch turned off, the power is taken away from solenoids, causing the cartridges to open and dump shift circuit pressure back to tank.

- **SOLENOID DIRECTIONAL VALVE**

This valve is a directional control valve that is shifted by electronically activated solenoids. Its purpose is to direct the flow of oil stored in the accumulator to one or the other end of the shift cylinder based on the signal received by the logic controller that was generated by the proximity sensor.

- **S-TUBE SHIFT SELECTOR BALL VALVE**

This is a manual ball valve used to control the speed of the s-tube shift. With valve fully opened (CCW), the flow is unrestricted, causing a fast hard shift of the s-tube. When the valve is closed (CW), the shift is slower as the flow must now pass through an orifice.

- **ACCUMULATOR**

The accumulator is incorporated into the shift circuit to provide instant pressure and volume for the shifting of the s-tube, which cannot be obtained under normal circumstances. An accumulator is a hydraulic reservoir that retains the hydraulic fluid under high pressure.

The accumulator contains a rubber bladder on the inside of the reservoir. The bladder is pre-charged with dry nitrogen. In the application of the shift circuit, the hydraulic fluid is pumped into the accumulator at a higher pressure than that inside the bladder. This compresses the bladder building up high pressure within the accumulator that is retained until released.



S-TUBE CIRCUIT OPERATIONAL SEQUENCE

In the operational sequence of the shift circuit with the engine at full RPM, the tandem pump is producing its rated displacement. The flow is going through the system and is being dumped or directed back to the tank thru the solenoid cartridges of the s-tube circuit manifold.

When the HORN/RESET switch is placed to RESET, an electrical signal closes the solenoid valve or cartridges. When this occurs the hydraulic fluid is now directed to the accumulator where it starts compressing the bladder and building up pressure. When the pressure in the shift circuit reaches a setting of the unloader valve, the unloader valve activates causing the relief cartridge to open. The open relief valve now directs the oil flow from the pump back to the tank instead of continuing to pressurize the accumulator. A check valve retains the pressure in the swing circuit and prevents the fluid from going back into the pump line.

In the main pump circuit description it was described how an electrical signal was generated by the proximity sensor which was sent to the logic controller and used to control the alternating action of the hydraulic drive cylinders. This same signal is also used to shift the s-tube so that its movement is synchronized with that of the hydraulic drive cylinder, shifting the s-tube to the material cylinder which is ready to extend (normal forward operation).

The electrical signal activates the solenoid coil of the directional valve, shifting the spool to the appropriate side. The accumulator then releases, exhausting the fluid which flows through the directional valve and is directed to the appropriate side of the shift cylinder. As soon as the shift is made the accumulator is refilled immediately and the sequence starts all over again.

AUXILIARY CIRCUIT

The auxiliary circuit has been designed and installed for the purpose of operating the hydraulic function of the auxiliary equipment on the unit, primarily the agitator. This function is that of the agitator rotation for mixing the material in the hopper and feeding of the concrete cylinders.

The flow and pressure requirements for the auxiliary circuit are met by employing the second stage or section of the same tandem pump used on the s-tube shift circuit. With the engine running and throttle set to maximum RPM, the flow from the tandem pump is directed to a single spool directional control valve. This circuit also utilizes a solenoid valve cartridge or dump valve, designed as a safety valve with the purpose of preventing flow to the auxiliary circuit as commanded by the emergency stop circuit. At start up, the normally open cartridge directs the oil flow from the tandem pump to tank, prohibiting function of the auxiliary circuit. When the emergency stop circuit is reset, an electrical signal is generated to energize the solenoid, closing the cartridge and blocking flow directly back to tank, instead allowing the flow to the single spool directional control valve for operation. The directional control valve has relief cartridge to protect the system against excessive pressure

When the agitator valve lever is activated the agitator will rotate in forward direction as hydraulic fluid is directed to that side of the motor. Rotation can be reversed by moving agitator lever in other direction.



OPERATION and MAINTENANCE

13822 Oaks Avenue
Chino, CA 91710
reedpumps.com
(909) 287 - 2100

Another common auxiliary circuit function is hydraulic outriggers. When hydraulic outriggers are used, a larger directional valve is used to accommodate the two extra functions, the near and far side outriggers. These functions work similar to the agitator described above but are electrically operated by solenoids. The solenoids are controlled by operating the up/down switch found in the outrigger switch box located on either side of the machine. Although the machine may be hydraulically lifted and lowered, the outrigger legs must always be pinned in position as with manual outriggers for added security and stabilization.



CONTROLS

1. SYSTEM POWER energizes the system enabling Engine Start Button.
2. ENGINE START starts the engine when the System Power Switch is ON.
3. CHECK ENGINE LIGHT (if equipped) is on when engine experiencing possible problems.
4. STOP ENGINE LIGHT (if equipped) indicates operator to stop engine immediately.
5. CONTROL ON LIGHT indicates control circuit energized.
6. DIGITAL DISPLAY (if equipped) displays engine RPM, oil pressure, volts, temperature, coolant level, strokes per minute, and status of systems.
7. HOUR METER records the number of hours the electrical system has been activated when the ignition key is ON.
8. HOPPER GRATE SAFETY SWITCH engages **EMERGENCY STOP** when grate is lifted
9. LOCAL or REMOTE controls intended operation of machine.
10. **EMERGENCY STOP stops all hydraulic functions of the concrete pump when pushed in. Pull the Emergency Stop Button out to enable system to reset; Horn/Reset must be pressed to reset pump operation.**
11. HORN/RESET activates system for operation
12. RPM +/- controls increase and decrease of engine RPM.
13. PUMP ON controls concrete pump ON/OFF function.
14. PUMP FORWARD REVERSE controls pump direction.
15. PUMP ON and PUMP REVERSE lights indicate pump status.
16. STROKE CHANGE changes stroke direction and eliminates proximity sensor signal while activated.
17. FAST CHANGE (if equipped) controls fast change feature for smoother operation under certain conditions. Used only on closed loop models.
18. VIBRATOR (if equipped-HOPPER OPTION) controls vibrator activation
19. VOLUME CONTROL (if equipped) controls volume output of the concrete pump.
20. DIAGNOSTIC INTERFACE (if equipped is accessible by **REED** and authorized **REED** dealers only) is a computer port for system settings and diagnostic testing.



ERROR CODES

- EC01** – No radio link (no signal from either radio or cable)
- EC02** – J1939 CAN link error
- EC03** – RPM Plus
- EC04** – RPM Minus
- EC05** – Volume Plus
- EC06** – Volume Minus
- EC07** – Horn
- EC08** – Vibrator
- EC09** – Safety Valve 1
- EC10** – Safety Valve 2
- EC11** – Pump Coil A
- EC12** – Pump Coil B
- EC13** – S Tube A
- EC14** – S Tube B
- EC15** – Reverse Coil Output – enabled when calibration checkbox for Reverse Logic Change is unchecked.
- EC16** – Fast Change – enabled when the calibration checkbox for Fast Change is checked.
- EC17** – Reverse Light Out Error
- EC18** – Pump Light Out Error
- EC19** – Check Engine Light
- EC20** – Stop Engine Light
- EC21** – Volume PWM Output Error
- EC22** – Prox A&B Error
- EC23** – Wrong ID
- EC24** – Engine RPM Overspeed
- EC25** – Oil Low Pressure
- EC26** – Coolant Over Temp.
- EC27** – Low Battery Voltage
- EC28** – High Battery Voltage
- EC29** – Denison Fast Change
- EC30** – Denison A (only on C series with Denison Hydraulic pumps)
- EC31** – Denison B (only on C series with Denison Hydraulic pumps)



VOLUME CONTROL KNOB or SWITCH adjusts volume output of the material
CLOSED LOOP Models utilize a PILOT pressure gauge as a scale of volume
COUNTERCLOCKWISE/+ To INCREASE Volume
CLOCKWISE/- To DECREASE Volume

CAUTION

Do Not Adjust Volume Output by Adjusting RPM
Adjust Volume Output by Adjusting Volume Control Knob



AGITATOR CONTROL controls agitator ON/OFF and FORWARD REVERSE functions.

HYDRAULIC OUTRIGGER CONTROLS/MANUAL OUTRIGGERS

Raises and lowers outriggers to stabilize machine and prevent damage to axle components. Pumping concrete with a load on the axle will damage or destroy axle, wheels, bearings, etc. **ALWAYS USE THE OUTRIGGERS WHILE PUMPING CONCRETE!**



S-TUBE SHIFT SELECTOR BALL VALVE controls the speed of the S-Tube shift.

Hard Shift - rotate ball valve lever counter clockwise (CCW). This position will be used for the majority of pumping applications.

Soft Shift - turn ball valve lever clockwise (CW). This position may be used when a slurry is being pumped or when the machine is being cleaned out.

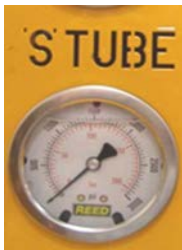
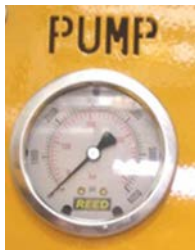

GAUGES

PUMP or DRIVE CYLINDER GAUGE indicates the hydraulic pressure requirement of the pumping cylinders to push material. Gauge reading varies depending upon many circumstances such as: material slump, material line type, size and length, vertical, uphill, downhill or horizontal placement, pumping speed, etc.

S-TUBE GAUGE indicates amount of oil pressure stored in accumulator circuit. Pressure will build and stabilize at a set pressure once E-STOP is reset. Pressure will fluctuate as swing cylinder(s) shift but will always recharge to the same set pressure.

PILOT GAUGE (CLOSED LOOP ONLY) indicates volume adjustment of main hydraulic pump. Works between a range of 90 PSI (6 Bar) min and 275 PSI (19 Bar) max.



CABLE REMOTE (RADIO REMOTE OPTIONAL, CONTACT **REED** FOR INFORMATION)

1. POWER ON/EMERGENCY STOP switch stops all functions of the concrete pump in OFF position. Move the Emergency Stop switch to ON to enable system reset; Horn/Reset must be pressed to reset pump operation.
2. CONTROL ON indicates control circuit energized.
3. HORN/RESET activates system for operation.
4. RPM +/- controls increase and decrease of engine RPM.
5. PUMP ON/OFF controls concrete pump ON/OFF function.
6. PUMP FORWARD/REVERSE controls pump direction.
7. VOLUME CONTROL (if equipped) controls volume output of the concrete pump.
8. STROKE CHANGE changes stroke direction and eliminates proximity sensor signal while activated.
9. FAST CHANGE (if equipped-closed loop only) controls the fast change feature for smoother operation under certain conditions

TOWING

Refer to the Safety Manual for towing safety precautions not limited to the following guidelines:



Ensure Unit Is Securely Attached Before Driving
Refer To Tow Hitch Instruction Manual



Tow Slowly and Safely Depending On Road Conditions
Overturning May Occur At Unsafe Speeds



NEVER Exceed 55 MPH



Maintain a Sufficient Distance for Braking
Overturning May Occur At Unsafe Stopping Distances



Do Not Tow With Concrete in the Hopper



Frequently Check, Monitor and Maintain all Towing Equipment
On Both the Towing Vehicle and the Trailer



Hitch Height

- Adjust the Hitch Height to Allow for Safe Towing
- The Tongue Weight on Tandem Axle Trailers Increases as the Tongue is Raised
 - Towing with Insufficient or Excessive Tongue Weight is Dangerous
 - Perform Road Tests to Ensure the Safety of the Tongue Weight

JOBSITE SET-UP

Refer to the Safety Manual for set-up safety precautions not limited to the following guidelines:

**WARNING**

Ensure Machine Can Be Safely Operated In Set-Up Location
Away From Hazards and Dangers
Away From Slopes and Excavations

**WARNING**

Position Machine On As Solid and Level Ground As Possible

**WARNING**

Place Outrigger Pads Below Outrigger Jacks If Necessary

**WARNING**

Secure Jack Positions with Outrigger Pins and Locks

CAUTION

Not Using Outriggers Voids Warranty
Damage Will Occur If Outriggers Are Not Used



PRIMING

Priming consists of pumping a lubricant to coat the s-tube and delivery lines to assist the initial concrete material in getting through the delivery lines and avoid blockages. Once the delivery lines are full of concrete, that material will supply the lubrication necessary for the material to flow through the delivery lines. However, it is imperative that a primer be used ahead of the initial concrete material to pre-lubricate the lines in order to avoid blockages.

A suggested grout to use for priming and lubrication may consist of 2 parts sand and 1 part cement and mixed to a consistency of a thick cream.

The amount of grout required depends on the length of the delivery line as well as the material being pumped. Operator experience will eventually indicate the amount to be required.

In addition to grout, there is a wide variety of priming products available on the market.



PUMPING CONCRETE

Everyone involved with the operation, maintenance, inspection, and repair of the concrete pump **MUST READ** and **UNDERSTAND** this manual and the **Safety Manual**.

Refer to the Safety Manual for pumping and blockages safety precautions not limited to the following guidelines:



Perform Required Inspection, Lubrication, and Maintenance
Before, During, and After Pumping Operations



Do Not Remove Hopper Grate
Or Other Safety Components



Do Not Insert Body Parts into Hopper, S-Tube, Flushbox
Or Other Moving Components



Turn Pump ON Only When Hopper Is Full Of Concrete



Ensure the following conditions are met before activating pump:

- PUMP Switch Is OFF
- VOLUME CONTROL Is Set To MINIMUM
- AGITATOR Control Is In OFF Position
- EMERGENCY STOPS Are Not Activated
- Controls On LOCAL Position
- HOPPER GRATE is CLOSED



PUMPING CONCRETE Continued

1. Turn KEY operated SYSTEM POWER Switch to ON
2. Press ENGINE START Button to start engine
3. Activate the HORN/RESET to prepare the concrete pump for operation
4. After engine warms up, increase RPM to desired engine RPM by adjusting THROTTLE CONTROL
5. Adjust VOLUME CONTROL to low output when starting pumping operations
6. Switch PUMP Switch to ON to pump concrete when hopper is full, maintain full level
7. Closely monitor the PUMP pressure gauge while pumping
8. Turn PUMP Switch to REVERSE to reverse the pumping action if necessary. REVERSE function is typically used to relieve pressure in the delivery line in the event of a blockage. A blockage will generally result in the main hydraulic system reaching maximum pressure as indicated on the PUMP PRESSURE GAUGE
9. Turn PUMP Switch OFF to stop cycling and stop pumping concrete
10. In the event of an emergency, push the EMERGENCY STOP Button IN to stop all functions of the concrete pump. Pull the EMERGENCY STOP Button OUT to enable system to reset; Horn/Reset function must be activated to reset pump operation.

JOBSITE CLEANUP



Do Not Remove Hopper Grate
Or Other Safety Components



Do Not Insert Body Parts into Hopper, S-Tube, Flushbox
Or Other Moving Components

1. Set VOLUME CONTROL to LOW
2. Pump as much material as possible out of the delivery system
3. Turn PUMP Switch OFF
4. Disconnect delivery system. Disconnect the line right after the reducer if a reducer is used
5. Open hopper door and empty hopper
6. Flush out hopper, S-Tube, and cylinders with water
7. Place DIRECTION Switch in REVERSE. Place no more than two feet of the water hose into the pump discharge outlet then turn the PUMP switch ON Water will drain into the material cylinders and as pump cycles, any sand and rocks will be forced out through the open clean out door.
8. Stroke the pump to make sure all sand and other material has been cleaned out, and then turn the pump off.
9. If the need to enter the hopper arises with any tool or any body part, refer to procedures in the Maintenance section (subsection called Component Replacement). Turn off the engine to shut down the system. Confirm that the equipment hold no pressure in any hydraulic system.
10. Close the hopper clean out door.
11. Place a clean out sponge into the disconnected delivery line. Reconnect the line to the hopper outlet or reducer with the sponge inserted as close to the hopper outlet as possible.
12. Fill the hopper with water. Place the DIRECTION Switch to the FORWARD position and check that VOLUME control is set at low speed. Turn PUMP Switch ON and cycle the pump until the sponge passes through the entire delivery system into a sponge catcher
13. Turn off the pump and allow the water to drain from the system
14. Clean up the remaining areas of the machine as needed
15. After clean up is complete lubricate all grease points to expel any grout before it cures



MAINTENANCE

RECOMMENDED MAINTENANCE PRACTICES

MAINTENANCE MANAGEMENT

Schedule lubrication and maintenance inspections to anticipate maintenance issues. Maintenance management requires the assignment of responsibilities to individual personnel, training of personnel, keeping of records, and the exercise of judgment.

INSPECTION AND LUBRICATION CHECKLISTS AND OPERATOR REPORTS

Utilize checklists for scheduled inspection and lubrication and maintain a written record regarding observations and actions performed. Maintain all scheduled maintenance reports by the operator listing any malfunctions and observations.

PUMP HISTORY FILE NOTING PUMP SERIAL NUMBER

File the operator reports, inspection and lubrication checklists, shop repair, work orders and tickets, parts replacement and pump usage records. This file should also include the parts book for the specific serial number and engine.

ANNUAL REVIEW

Review the history records of each unit once every year to find evidence of repetitive failures, adjustments, problems, or excessive wear so that action can be taken to minimize breakdowns and reduce excessive maintenance costs. A review of the machine history will help in the stocking of spare parts and assemblies in advance of a possible need.



Engine Manufacturer Maintenance Schedule Must Be Followed
Read Engine Manufacturer Manual

REED has provided only general guidelines regarding engine maintenance, and will not cover engine warranty claims.



Hydraulic Pressure in All Systems Must Be ZERO
Before And During Any Maintenance Procedures



Engine Must Be Turned OFF and Lockout / Tagout Procedures Must Be Followed
Before And During Any Maintenance Procedures



GENERAL MAINTENANCE AREAS

Perform scheduled inspections to identify and detect any potential problems. The list presented should be inspected and checked on a regular basis and is a recommended minimum.

TRAILER

- Frame integrity, visually check welds, cracks
- Torsion axle secure
- Wheels and tires, lug nuts tight, tire pressure, bearings oiled/greased and adjusted, dust caps on and secure
- Electric brakes, breakaway switch connected
- Front jack stand handle turns easily, smoothly
- Manual jacks slide freely, lock pins in place
- Lighting and Wiring in good condition, operational

ENGINE (refer to engine manufacturer manual)

- Inspect mounts, bolts, brackets and belts
- Oil and coolant fluids at proper level, check for leaks
- Fuel system, tank mounting, filter condition, leaks, damaged lines
- Battery hold down, condition, tightness of cables
- Key switch, indicator lights
- Throttle control functional
- Air cleaner and muffler securely mounted

PUMP CELL

- Visually check for structural damage, cracked welds
- Hydraulic drive cylinders in good condition, secure, check for leaks
- Material cylinders secure, tie rods tight
- Water box structurally sound, clean, cover in place
- S-Tube shift mechanism structurally sound, all pins and retainers in place
- Hydraulic shift cylinder(s) in good condition
- Bearing housing, seals etc. in good condition
- Hydraulic hoses secure no leaks

HOPPER ASSEMBLY

- Visually check for structural damage, cracked welds
- S-Tube secure, in good condition
- Check condition of wear plate, wear ring, seals
- Check connection of s-tube to outlet, seals, bearing
- Hopper Grate, Hinges and Bushings in good condition
- E-STOP Hopper Grate Sensor is operational and in good condition
- Hopper drain is functional
- Hopper is clean
- Zerk fittings accept grease



OPERATION and MAINTENANCE

13822 Oaks Avenue
Chino, CA 91710
reedpumps.com
(909) 287 - 2100

MAIN CONTROLS

- Control box in good condition, sealed, not damaged
- All toggles in good condition, stay in position or momentarily return to center
- Control identification in good condition, legible
- Gauges in good condition

REMOTE CONTROLS

- Control console in good condition, not damaged
- Switch in good condition
- Cord in good condition, no cuts, securely mounted to box

HYDRAULIC SYSTEM

- Hydraulic tank securely mounted, covers tight
- Breather, filler cap and strainer in place, level sight gauge in proper condition
- Check filter condition indicators
- Hydraulic oil cooler securely mounted, connections tight
- Check accumulator condition, mounting brackets & clamps
- Hydraulic fluid to proper level and clean
- All hoses and tubing secure, check for leaks



LUBRICATION

The **REED** concrete pump is equipped with several components that require frequent lubrication. These areas involve the s-tube shifting mechanism, swing components, the shift and outlet bearings and agitator. To insure the economical service and the long life of these components, grease fittings are installed at each point.

Rapid wear and possible shutdown will result if the unit is operated with inadequate lubrication. Follow the recommendations stated herein, and if needed increase the application of lubricants above these recommendations when the equipment is subject to heavy usage.

RECOMMENDED LUBRICATING INTERVALS

Recommended lubrication intervals are based on normal use under normal conditions. The lubrication interval must be increased to meet more challenging uses and uses which subject the equipment to high and/or unusual concentration of forces. The lubrication interval must be increased if the pump has been exposed to environmental conditions such as low humidity, high humidity, excessive dust, high temperatures, low temperatures, heavy rainfall, long term storage, ocean air, etc...

- 1) every hour of operation
- 2) after completion of every job

All lubrication points must be greased on each and every interval as recommended.

TYPE OF LUBRICANT

- Use EP grease, extreme pressure grease available for wheel bearings, general purpose grease, Shell Alvania EP (LFH2), or equivalent if this lubricant is unavailable in your area
- Do NOT use Moly grease, grease with Moly additives

LUBRICATION POINTS

The following graphics are for REFERENCE ONLY.

S-TUBE SHIFT LUBRICATION

CAUTION

IF EQUIPPED WITH DUAL (2) HYDRAULIC SHIFT CYLINDERS,
RELIEVE SHIFT CIRCUIT HYDRAULIC PRESSURE TO PROPERLY GREASE
HYDRAULIC SHIFT CYLINDERS AND BELL CRANK

STUBE BEARING
GREASE POINTS

SINGLE SHIFT

DUAL SHIFT

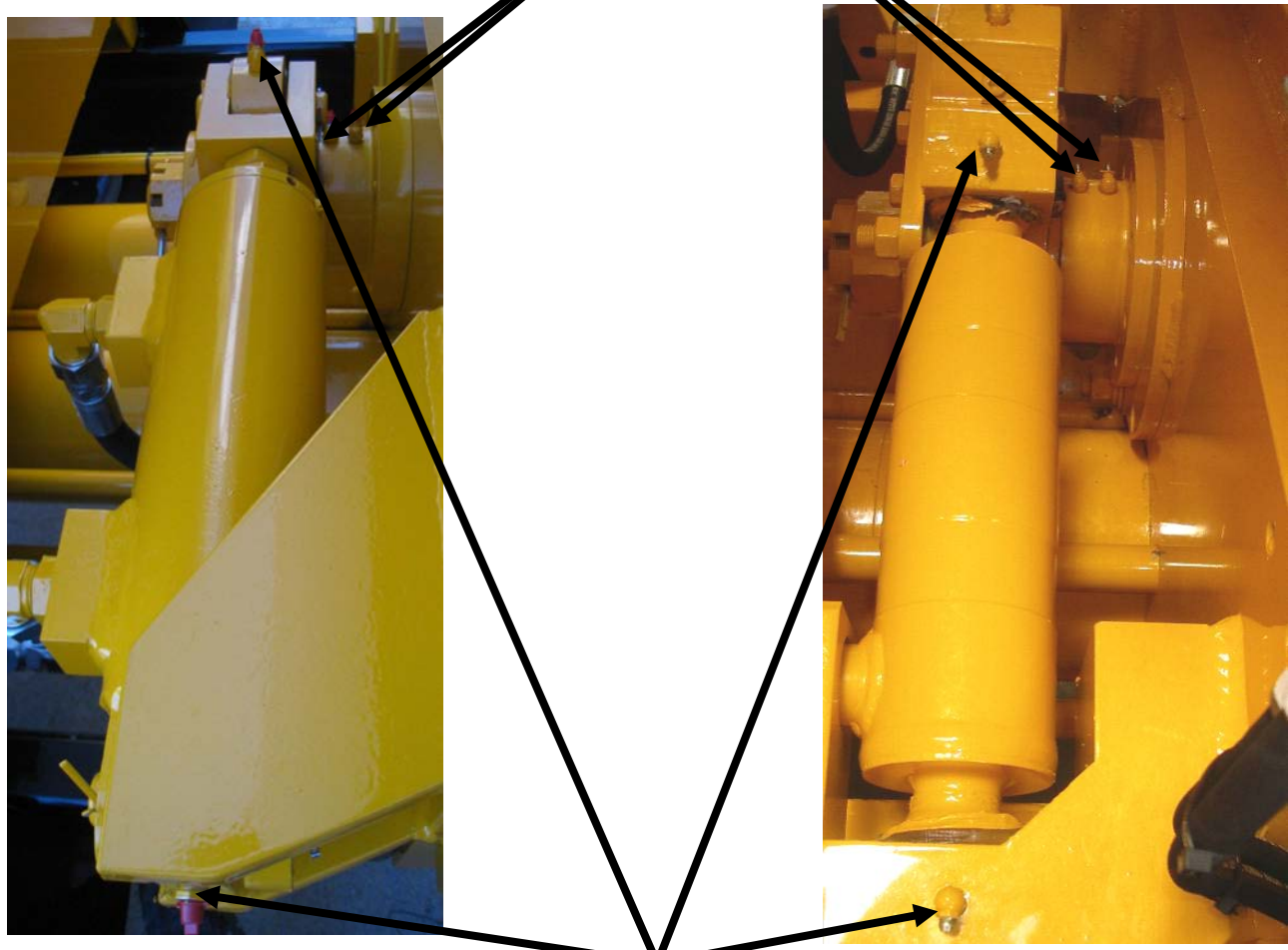

BELL CRANK AND SHIFT
CYLINDER GREASE POINTS

*NOTE: RELIEVE S-TUBE CIRCUIT PRESSURE BEFORE
APPLYING GREASE IF EQUIPPED WITH DUAL (2) SHIFT CYLINDERS*

S-TUBE OUTLET LUBRICATION

4" S-TUBE OUTLET GREASE POINTS

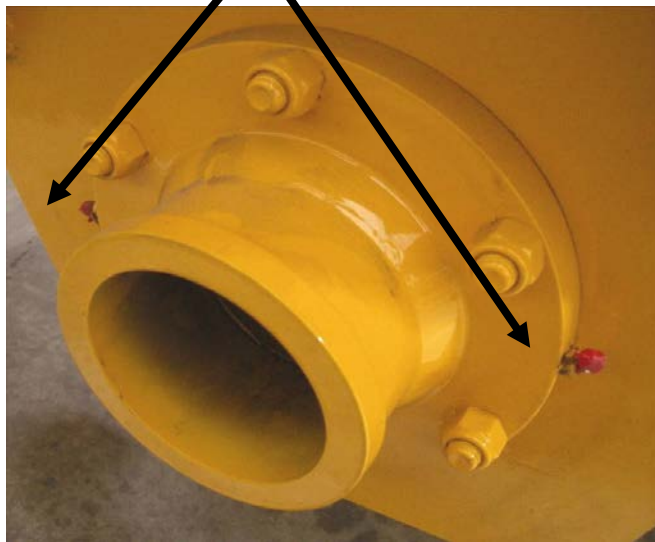

5" S-TUBE OUTLET GREASE POINTS



AGITATOR LUBRICATION

HARSH MIX HOPPER
HYDRAULIC MOTOR SIDE
GREASE POINT

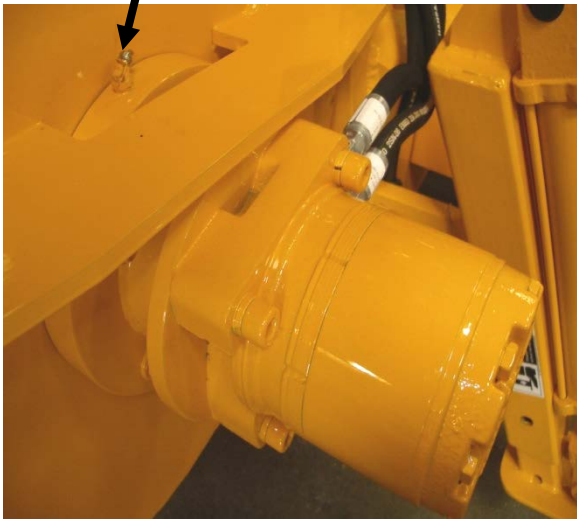

HARSH MIX HOPPER
NON-HYDRAULIC MOTOR SIDE
GREASE POINTS

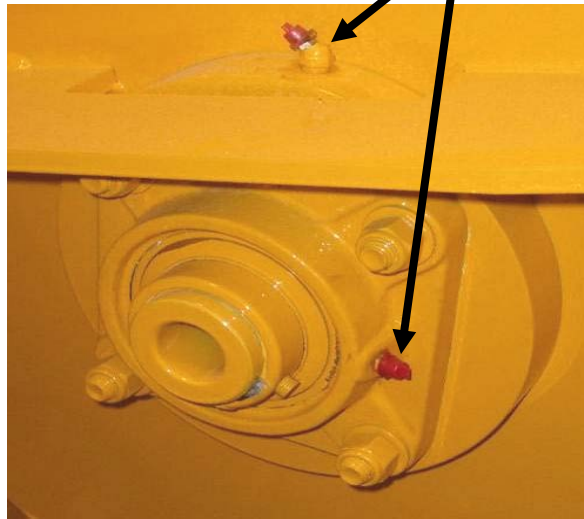

STANDARD HOPPER
HYDRAULIC MOTOR SIDE
GREASE POINT



STANDARD HOPPER
NON-HYDRAULIC MOTOR SIDE
GREASE POINT





HYDRAULIC SYSTEM

Hydraulic pumps are used to supply the flow of oil necessary to operate actuators of the concrete pump.



Contamination of the Oil Is the Leading Contributor to System Malfunctions

Extreme care must be exercised to prevent contaminants from entering the system. Always cap or plug open ports and hydraulic lines.

HYDRAULIC TANK

Hydraulic tank can be equipped with an access cover with breather. A sight and temperature gauge is installed on the tank to determine the fluid level and temperature inside the tank. The tank is also equipped with drain valve.

To accomplish filtration, hydraulic tanks can be equipped with the following: internal magnetic suction strainers, a suction filter, a return filter and a pressure filter.

NOTE: Not all models use all of these components. Suction and return filters are equipped with an indicator gauge to monitor filter restriction. An oil cooler is adjacent to the engine cooling unit.



OPERATION and MAINTENANCE

13822 Oaks Avenue
Chino, CA 91710
reedpumps.com
(909) 287 - 2100

HYDRAULIC SYSTEM MAINTENANCE ITEM DESCRIPTIONS

FLUID

Check fluid level and oil clarity daily with sight gauge provided. Maintain level at full mark. Add hydraulic oil through the return filter fill port when necessary.

TANK BREATHER

Clean every 50 hours of operation. Remove from tank, clean with solvent and air blow dry.

FILTER

Change after first 50 hours of operation. Thereafter change every 250 hours of operation or when condition gauge indicates change is necessary.

HYDRAULIC TANK

Change oil in tank every 500 hours of operation or yearly, whichever comes first.

HYDRAULIC FLUID

The hydraulic system is filled with Shell Oil Company TELLUS #46. It is to be used in ambient temperatures of 39-90° F (4-32° C). The normal fluid temperature will range from 100-167° F (38-75° C).

For ambient temperatures of 90° F (32° C) and above, use fluid designated with an ISO rating of 68. Use ISO 32 for ambient temperatures of 32° F (4° C) and below.

CAUTION

Use Only Shell Tellus 46 or Equivalent
Never Mix With Other Types of Fluids

CAUTION

Always Use Clean and New Fluid

Using impure or other type of fluids not specified will contaminate the hydraulic system and lead to eventual system malfunction and/or damage.

ADDING HYDRAULIC FLUID

There are a few common methods for filling the hydraulic tank as described below. Exercise extreme care when adding fluid to the hydraulic tank to avoid contamination.

- To prevent any dirt or water from entering the hydraulic tank, thoroughly clean area around the return filter fill port plug, the vented fill cap or the inspection cover.
- Remove return filter fill port plug, vented cap or inspection cover.
- Fill system to MAX LEVEL mark on sight gauge with new clean hydraulic fluid.

If a pump is used to transfer the fluid, ensure the pump filter is clean. If pouring fluid from a container, pour it through a fine wire mesh screen, 200 mesh or finer.

- Replace filter fill port plug, vented cap or inspection cover immediately after filling tank to proper level.

CAUTION

Do Not Use Cloth for Straining Fluid
Lint Is a Contaminant Harmful To the Hydraulic System

FILTER SERVICING

Hydraulic filters provide a means of continuous hydraulic fluid filtration in an effort to prevent recirculation of contamination which will cause rapid wear and component breakdown.

A filter that is equipped with a condition indicator gauge should be checked daily and the element changed when indicated to do so. Below are TYPICAL filters and filter elements.

RETURN FILTER

FILTER INDICATOR FILL PORT



FILTER ELEMENT



SUCTION FILTER

FILTER INDICATOR



To change the filter elements:



1. Shut off machine.
2. VERIFY PRESSURES IN ALL CIRCUITS READ ZERO!
3. Wipe clean any dirt and grime from area surrounding filter housing
4. Loosen the filter cover plate bolts
5. Carefully remove cover so as not to damage the gasket or O-ring
6. Remove and element bypass valve (if equipped)
7. Discard only element and discard responsibly
8. Install bypass valve (if equipped) and new element and replace cover
9. Wipe clean any contaminants around high pressure filter
10. Remove filter housing then remove and discard filter element
11. Check and replace o-ring or gasket if necessary
12. Replace filter element and install filter housing
13. Start up machine and observe for leakage



Do Not Wash Out and Reuse Disposable Filter Elements

CLEANING THE HYDRAULIC TANK

The hydraulic tank should be drained and cleaned after 500 hours of operation or yearly, whichever occurs first, to assist in keeping the systems clean and in proper condition.

1. Shut off machine
2. VERIFY PRESSURES IN ALL CIRCUITS READ ZERO!
3. Place a suitable size container under the hydraulic tank drain fitting and then remove drain plug. Dispose of used oil responsibly
4. After draining, remove the access cover on the hydraulic tank being careful not to damage the gasket
5. Remove, disassemble and clean magnetic suction strainers before reassembly (if equipped)
6. Flush the inside of hydraulic tank with clean solvent and wipe clean with lint free cloths
7. Install suction strainers (if equipped)
8. Replace sight gauge
9. Install the tank drain plug and access cover with gasket.
10. Change the hydraulic system filter element(s) and breather cap
11. Refill the hydraulic tank with new clean hydraulic fluid to MAX LEVEL mark
12. Start machine and check for leaks



COMPONENT REPLACEMENT

When parts are worn, do not delay in replacement. Continued usage with worn parts may lead to damage of other components.

This section is provided as a general guideline to assist in replacing major components that will wear. Please contact the **REED** Service Department or your local dealer for technical support.

S-TUBE, WEAR RING, AND WEAR PLATE

The sealing characteristics of the s-tube depend on the positive contact of the wear ring, located inside the s-tube, to the wear plate mounted inside of the hopper. The abrasiveness and friction of the concrete will cause wear and a breakdown of the sealing action. As this breakdown occurs, periodic adjustments to the s-tube can be made. This will help to improve the sealing quality; however, eventually the components will need to be replaced.

Adjustment or parts are required if:

- s-tube concrete build up
- deep grooves have developed on the face of the wear plate and/or on the wear ring
- When the output volume at the end of the delivery line noticeably begins to decrease or eventually stops
- When the material being pumped is being forced back into the hopper under pressure



Pressures in All Hydraulic Circuits Must Be ZERO
BEFORE AND DURING Any Maintenance Procedures



Engine Must Be Turned OFF and Lockout / Tagout Procedures Must Be Followed
BEFORE AND DURING Any Maintenance Procedures

NOTE: The following graphics are for REFERENCE ONLY.



OPERATION and MAINTENANCE

13822 Oaks Avenue
Chino, CA 91710
reedpumps.com
(909) 287 - 2100

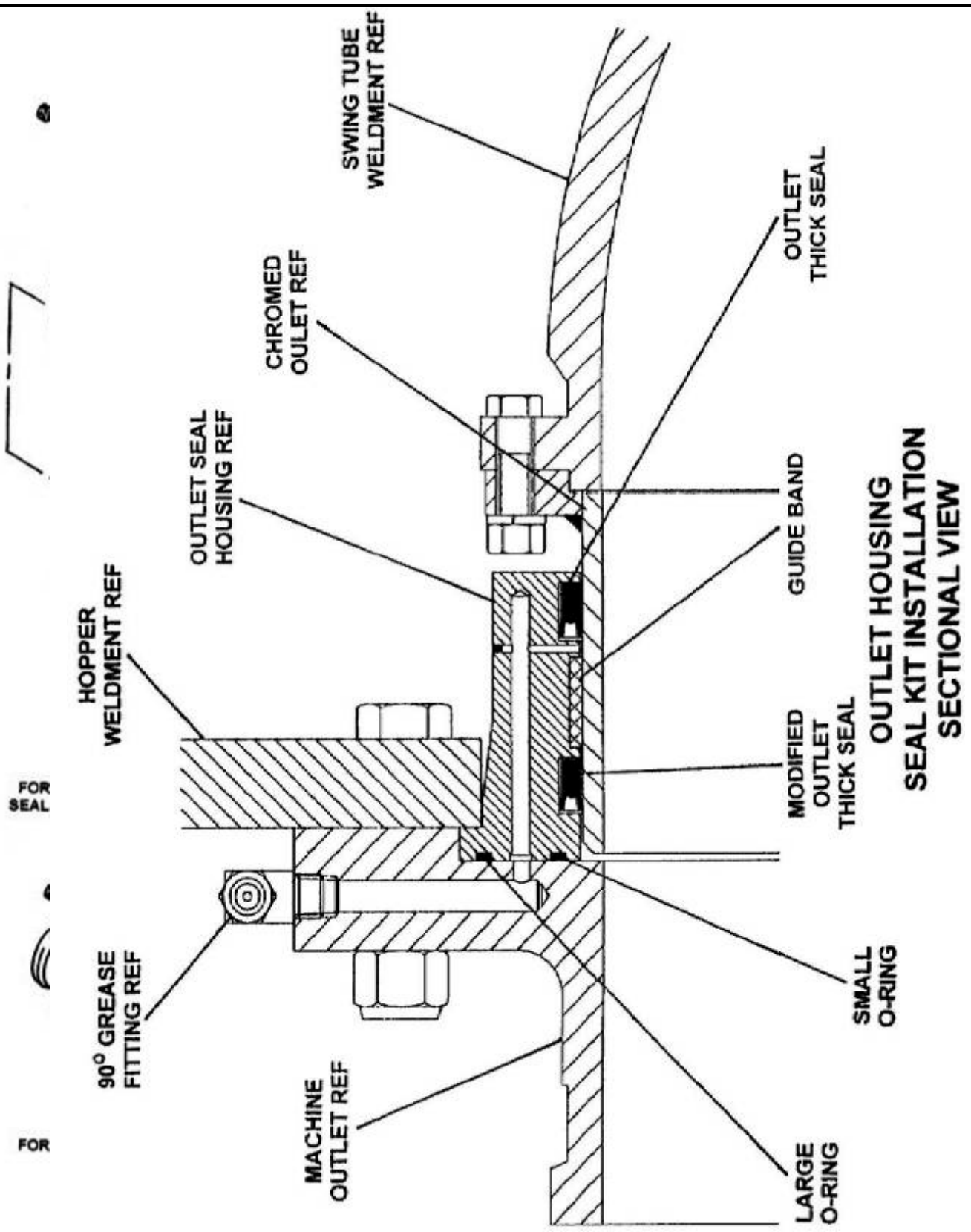



OPERATION and MAINTENANCE

13822 Oaks Avenue
Chino, CA 91710
reedpumps.com
(909) 287 - 2100

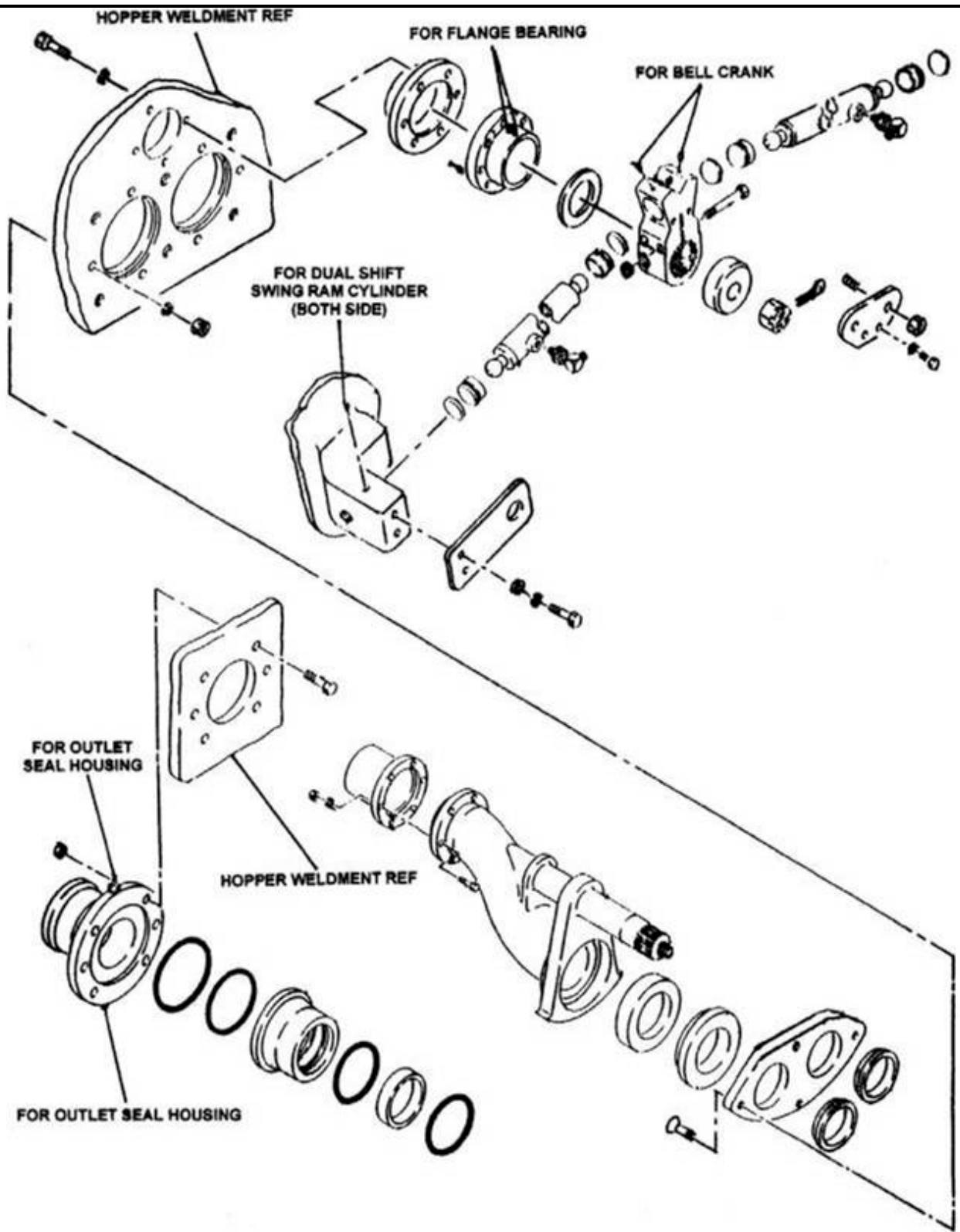

DUAL SHIFT PUMPING TRAIN



Pressures in ALL Hydraulic Circuits Must Be ZERO
BEFORE AND DURING Any Maintenance Procedures



Engine Must Be Turned OFF and Lockout / Tagout Procedures Must Be Followed
BEFORE AND DURING Any Maintenance Procedures

1. Shut off machine
2. VERIFY PRESSURES IN ALL CIRCUITS READ ZERO!
3. Loosen bell crank pinch bolt (s), remove cotter pin, loosen s-tube nut 1 turn
4. Remove outlet bolts, remove outlet
5. Remove outlet seal housing followed by s-tube nut, spacer, bell crank, washer, swing ram(s)
6. Place a sling from an overhead hoist around the discharge end of s-tube to help support the tube.
7. Pry s-tube toward outlet, remove wear ring & thrust seal. The s-tube may be swung upside down to provide access to clean. Thrust seal groove or cavity must be properly cleaned

Note: for better access, the s-tube may be removed from hopper by removing flange bearing, seal and chromed outlet and hoisting it out of hopper

8. If wear plate is to be changed, remove wear plate mounting bolts. Pry wear plate from hopper using provided jack bolt.
9. Pry anti-chip rings out of hopper bore. Use caution not to damage chrome concrete cylinder. Clean anti-chip ring bore and wear plate area. Replace o-rings (if applicable). Test-fit new bolts in new wear plate-they should be below the surface of the wear plate and not protruding (grind if necessary).
10. Apply small bead of silicone to outer diameter of anti-chip rings, install into hopper bore with split at bottom
11. Apply small amount of silicone to hopper-side of wear plate and bolt-heads. Install wear plate, hand tighten bolts. A short pair of bolts with nuts may be placed underneath new wear plate to adjust and align to concrete cylinders. Torque wear plate mounting bolts to 250 ft lbs, remove adjusting bolts.
12. Install new thrust seal & wear ring in s-tube.
13. Install shaft seal and flange bearing (if removed), torque bolts to 100 ft lbs



OPERATION and MAINTENANCE

13822 Oaks Avenue
Chino, CA 91710
reedpumps.com
(909) 287 - 2100

14. Slide s-tube forward against wear plate, install washer, align/ mount bell crank, install spacer and castle nut. Do not tighten yet.
15. Replace outlet seals in proper orientation, apply grease and install outlet seal housing. Install outlet, torque outlet bolts to 100 ft lbs. Grease all zerk fittings for s-tube until grease comes out of seals.
16. Remove sling, tighten s-tube nut/bolt. It may be helpful to start machine and cycle s-tube to help new parts seat. Do final tightening to s-tube nut/bolt, install cotter pin/retainer, tighten bell crank pinch bolt (s). The nut should be as tight as possible without hampering the shift of s-tube

S-TUBE ADJUSTMENT



Pressures in ALL Hydraulic Circuits Must Be ZERO
BEFORE AND DURING Any Maintenance Procedures



Engine Must Be Turned OFF and Lockout / Tagout Procedures Must Be Followed
BEFORE AND DURING Any Maintenance Procedures

The s-tube will require periodic adjustment as the wear parts wear in order to ensure the good contact and sealing characteristics of the wear plate and wear ring, as well as maintaining a constant squeeze of the thrust seal behind the wear ring. S-tube adjustment is performed by tightening the castle nut. Generally, the castle nut should be as tight as it can be without slowing or hindering the throw of the s-tube.

1. With engine off and no pressure showing on gauges, loosen the bell crank pinch bolts
2. Remove cotter pin and tighten castle nut one flat or to next cotter pin slot.
3. Start and cycle machine to ensure proper s-tube operation. Adjust further if necessary, following lock out tag out rule for each adjustment.
4. When adjustment has been satisfied, install cotter pin and tighten bell crank pinch bolts.

PISTON CUP AND GUIDE BAND REMOVAL/REPLACEMENT

Because of the abrasiveness of the material being pumped, it will be necessary to periodically replace the piston cups. Signs and indicators of worn parts might be:

- The slurry or abrasive material being pumped starts to appear in flush box
- Leading edge of piston cup is noticeably deteriorated or unevenly worn
- The water or lubricating oil in water box begins to rapidly lower level without any sign of leakage
- Operation is rough and erratic



Pressures in ALL Hydraulic Circuits Must Be ZERO
BEFORE AND DURING Any Maintenance Procedures



Engine Must Be Turned OFF and Lockout / Tagout Procedures Must Be Followed
BEFORE AND DURING Any Maintenance Procedures

1. Drain all oil or water from the flush box.
2. Cycle machine using appropriate controls until one of the cylinders is completely retracted. Turn off engine and allow hydraulic systems to completely depressurize.
3. As a precaution, mark location of proximity sensor adjusting bracket. Remove proximity sensor cross bracket.
4. Mark the end of the piston coupler so that it can be placed in the same relation during reassembly.
5. Unbolt and remove top and bottom halves of coupler. Pry the piston assembly into flush box.
6. Disassemble and clean piston adapter and plate. Check flatness of plate, replace if necessary.
7. Install and grease new guide band. Push adapter/guide band squarely into cleaned and greased concrete cylinder.
8. Install coupler using medium strength Loctite on bolts and torque to 90 ft lbs.
9. Start and completely extend the adapter and guide band to hopper side. Run in Forward or Reverse as necessary to expose fully extended piston adapter.
10. Turn off engine and allow all hydraulic systems to completely depressurize

11. Install one alignment bolt (3/8"x24x5" with head cut off) into the piston adapter to assist in

- locating the cup in the correct position to line up the holes.
12. Slide new piston cup, small end first, over alignment bolt until it meets wear plate. Use a rubber hammer to drive piston cup into concrete cylinder until it seats against piston adapter
 13. Slide piston plate into place.
 14. Apply medium strength Loctite to bolts. After three bolts with lock washers are started, remove alignment bolt and thread in the last bolt. Tighten bolts equally and firmly using hand tools.
 15. One concrete piston is complete. Follow steps 2-14 again for the other side.
 16. Install proximity sensor cross bracket.
 17. Install flush box plug, fill to top of rods with oil or water, and install flush box cover.

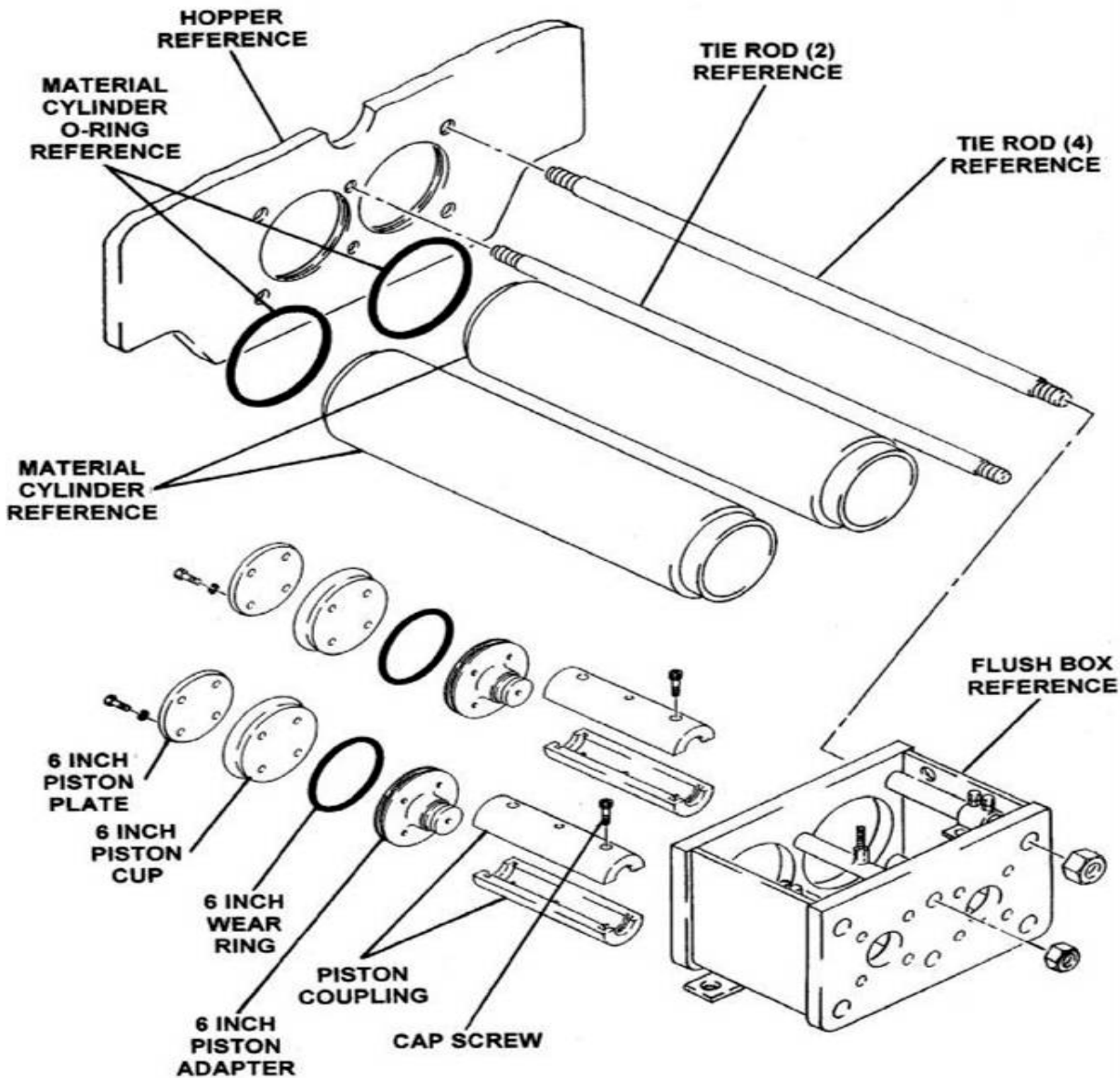

ACCUMULATOR

Pressures in ALL Hydraulic Circuits Must Be ZERO
BEFORE AND DURING Any Maintenance Procedures



Engine Must Be Turned OFF and Lockout / Tagout Procedures Must Be Followed
BEFORE AND DURING Any Maintenance Procedures



The hydraulic accumulator is a pressurized vessel and only QUALIFIED TECHNICIANS should perform the necessary repairs. Always drain the fluid COMPLETELY from the accumulator before performing any work on the component.

A qualified technician can check the pre-charge pressure of the accumulator using an accumulator charge kit if low pressure is suspected. Check the pre-charge pressure of the accumulator if the needle of the hydraulic s-tube gauge does not suddenly drop off at the specified pressure when the hydraulic s-tube circuit is depressurizing, or if the s-tube action is noticeably slow and weak.



PUMP MAINTENANCE SCHEDULE AND CHECKLISTS

Providing a maintenance schedule defined specifically by run hours or yardage pumped serves only as a general guideline given the large amount of variables a unit might be subject to, such as weather and ambient temperature conditions, jobsite conditions, material differences of concrete mix design, the load burden the unit is typically subject to, i.e. light, medium or heavy duty operation, etc.

The list that follows is to be used as a reference guide. However, the end user is encouraged to develop a preventative maintenance program that specifically suites their needs depending on the usage of the equipment.

DAILY PUMP MAINTENANCE CHECKLIST		
Actual Hours _____		Date ___ / ___ / ___
#	Maintenance Description	Initials
1	Check hydraulic tank fluid levels	
2	Check condition of hydraulic oil for water or other contamination.	
3	Drain water from hydraulic tank	
4	Check flush box fluid levels NOTE: If water is used instead of oil, water should be drained DAILY	
5	Check engine fluid levels (see engine manufacturer maintenance schedule for additional requirements)	
	Additional Notes:	
6	Check hydraulic filter indicator condition	
7	Lubricate lubrication points, during and after pumping	
8	Inspect unit for fluid leaks, loose hoses, loose nuts, bolts, fasteners etc.	
	Additional Notes:	
9	Trailer Towing Safety Inspection	
	a) brakes functional	
	b) air pressure in tires is adequate and tire condition	
	c) all "lug nuts" are secure and in place	
	d) Wheel bearings properly lubricated, adjusted, dust caps secure	
	e) tow hitch is secure and in good condition	
10	Additional Notes:	



OPERATION and MAINTENANCE

13822 Oaks Avenue
Chino, CA 91710
reedpumps.com
(909) 287 - 2100

INITIAL 50 HOUR MAINTENANCE CHECKLIST		
Actual Hours _____		Date ___/___/___
#	Maintenance Description	Initials
1	Change engine oil and filters (see engine manufacturer maintenance schedule for additional requirements)	
	Additional Notes:	
2	Change hydraulic oil filters	
3	Inspect hydraulic hoses and fittings for any signs of external wear or damage	
	Additional Notes:	



OPERATION and MAINTENANCE

13822 Oaks Avenue
Chino, CA 91710
reedpumps.com
(909) 287 - 2100

EVERY 100 HOUR MAINTENANCE CHECKLIST		
Actual Hours _____		Date ___/___/___
#	Maintenance Description	Initials
1	Clean hydraulic tank breather	
2	Inspect all structural components (check frame, hopper, axle, hood, towing hook, and other structural members for any damage)	
	Additional Notes:	
3	Adjust "S-Tube Nut" or "Castle Nut" (refer to "S-Tube Adjustment" in Maintenance Section)	
	Additional Notes:	
4	Change flush box oil and examine for excessive amounts of contamination (excessive contamination might indicate need to change the Piston Cups)	
	Additional Notes:	
5	Check coolers and radiators for dirt or debris. Clean as necessary	
6	Check condition of engine drive belts. Change if necessary (see engine manufacturer maintenance schedule for additional requirements)	
Additional Notes:		



OPERATION and MAINTENANCE

13822 Oaks Avenue
Chino, CA 91710
reedpumps.com
(909) 287 - 2100

EVERY 250 HOUR MAINTENANCE CHECKLIST		
Actual Hours _____		Date ___/___/___
#	Maintenance Description	Initials
1	Change hydraulic filters (or change more frequently as indicated by indicator gauge on filter)	
2	Check that S-Tube, wear parts and seals in hopper are secure and adjusted well, rotate wear ring and replace seal if necessary	
	Additional Notes:	
3	Check swing cylinder components: cylinders, bell crank, pins, bushings, bearings and grease fittings are secure, tight, and not worn excessively	
	Additional Notes:	
4	Check piston cup wear (as indicated by analysis of contaminants found in flush box oil)	
	Additional Notes:	
5	Check that all electrical wires, cables, terminals, plugs are in good condition	
	Additional Notes:	
6	Change engine oil and filters (see engine manufacturer guide for all engine requirements)	
	Additional Notes:	
7	Check condition of fuel hoses, fittings, and clamps	
	Additional Notes:	
8	Inspect all safety decals to ensure that they are completely visible and legible	



OPERATION and MAINTENANCE

13822 Oaks Avenue
Chino, CA 91710
reedpumps.com
(909) 287 - 2100

EVERY 250 HOUR MAINTENANCE CHECKLIST		
Actual Hours _____		Date ___/___/___
#	Maintenance Description	Initials
9	Perform complete inspection of the controls	
10	All toggles in good condition, stay in position or momentarily return to center	
11	Control identification in good condition, legible	
12	Gauges in good condition	
	Additional Notes:	
13	Remote controls, control console in good condition	
14	Switch in good condition	
15	Cord in good condition, no cuts, securely mounted to box	
	Additional Notes:	
16	Trailer frame integrity, visually check welds, cracks	
17	Torsion axle secure	
18	Wheels and tires, lug nuts tight, tire inflation	
19	Wheel Bearings properly lubricated and adjusted, dust caps secure	
20	Electric brakes, breakaway switch connected	
21	Front jack stand handle turns easily, smoothly	
22	Manual jacks slide freely, lock pins in place	
23	Lighting good condition operational	
Additional Notes:		



OPERATION and MAINTENANCE

13822 Oaks Avenue
Chino, CA 91710
reedpumps.com
(909) 287 - 2100

EVERY 500 HOUR MAINTENANCE CHECKLIST		
Actual Hours _____		Date ___/___/___
#	Maintenance Description	Initials
1	Inspect hydraulic hoses and fittings for any signs of external wear or damage	
	Additional Notes:	
2	Inspect all wear parts and change as necessary (excessive wear may cause inefficient performance and/or shutdown of operation)	
	Additional Notes:	
3	Change hydraulic fluid, clean the reservoir and the suction strainers within reservoir, and replace all hydraulic oil filters	
	Additional Notes:	
4	Complete inspection of the engine (refer to engine manufacturer maintenance schedule for details)	
5	Inspect mountings, bolts, brackets	
6	Oil level proper, coolant level proper, check for leaks	
7	Fuel system, tank mounting, filter condition, check for leaks, damaged lines	
8	Battery hold down, condition, tightness of cables	
9	Key switch, indicator lights operable	
10	Throttle control functional	
11	Air cleaner and muffler securely mounted	
Additional Notes:		



OPERATION and MAINTENANCE

13822 Oaks Avenue
Chino, CA 91710
reedpumps.com
(909) 287 - 2100

EVERY 500 HOUR MAINTENANCE CHECKLIST		
Actual Hours _____		Date ___/___/___
#	Maintenance Description	Initials
12	Pump cell check for structural damage, cracked welds	
13	Hydraulic drive cylinders in good condition, secure, check for leaks	
14	Material cylinders secure, tie rods tight	
15	Water box structurally sound, clean, cover in place	
16	S-Tube shift mechanism structurally sound, all pins and retainers in place	
17	Hydraulic shift cylinders in good condition	
18	Bearing housing, seals etc. in good condition	
19	Hydraulic hoses secure no leaks	
	Additional Notes:	
20	Hopper check for structural damage, cracked welds	
21	S-Tube secure, in good condition	
22	Check condition of wear plate, wear ring, seals	
23	Check connection of S-Tube to outlet, seals, bearing	
24	Hopper drain is functional	
Additional Notes:		



OPERATION and MAINTENANCE

13822 Oaks Avenue
Chino, CA 91710
reedpumps.com
(909) 287 - 2100

EVERY 500 HOUR MAINTENANCE CHECKLIST	
Actual Hours _____	Date ____/____/____
ADDITIONAL GENERAL NOTES:	



OPERATION and MAINTENANCE

13822 Oaks Avenue
Chino, CA 91710
reedpumps.com
(909) 287 - 2100

NOTES

HYDRAULIC AND ELECTRICAL SCHEMATICS

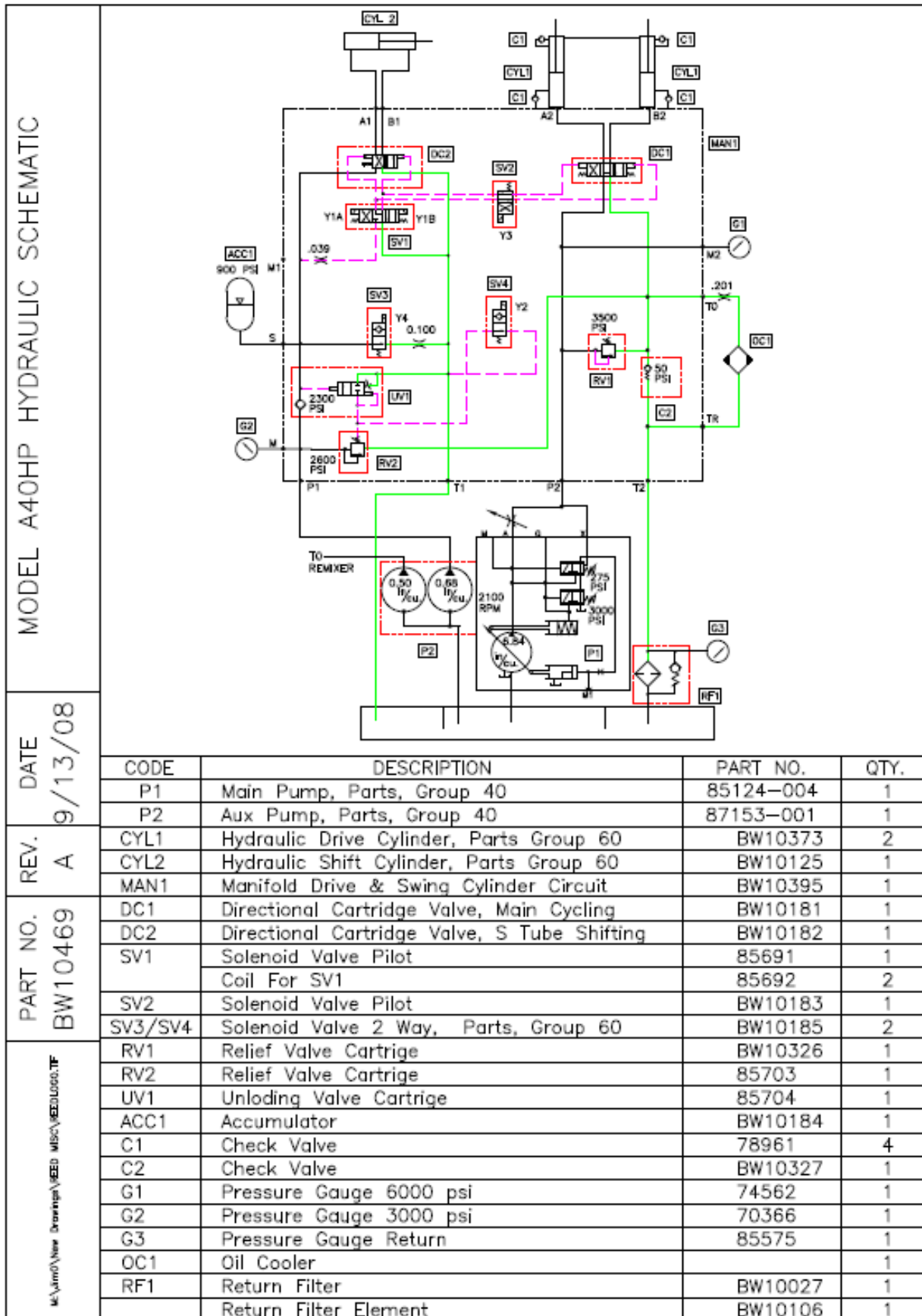

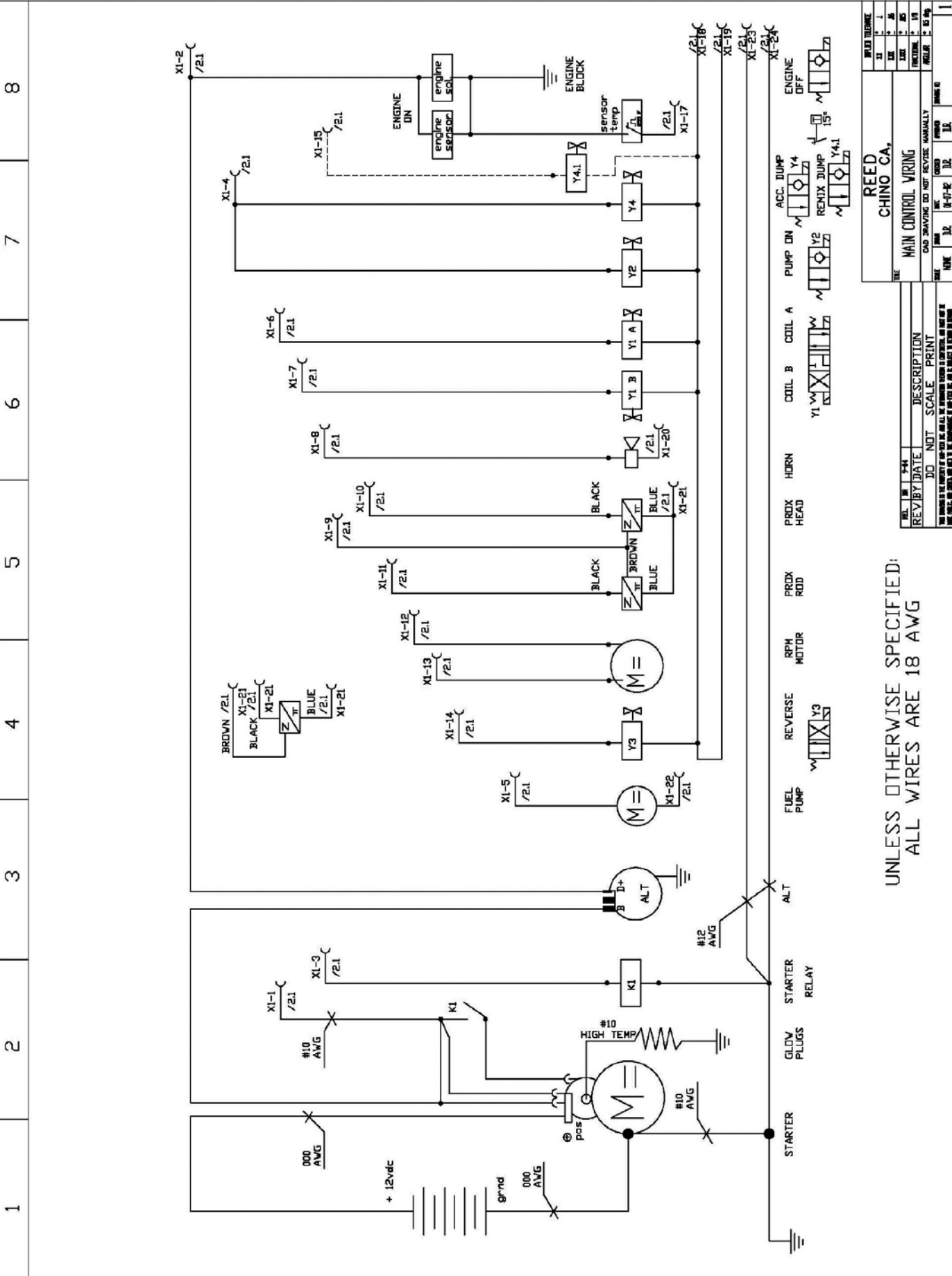

UNLESS OTHERWISE SPECIFIED:
ALL WIRES ARE 18 AWG

REV. NO.	DATE	DESCRIPTION
DD	NOT SCALE	PRINT

REV. NO.	DATE	DESCRIPTION
DD	NOT SCALE	PRINT

REV. NO.	DATE	DESCRIPTION
DD	NOT SCALE	PRINT

REV. NO.	DATE	DESCRIPTION
DD	NOT SCALE	PRINT

REV. NO.	DATE	DESCRIPTION
DD	NOT SCALE	PRINT

REV. NO.	DATE	DESCRIPTION
DD	NOT SCALE	PRINT

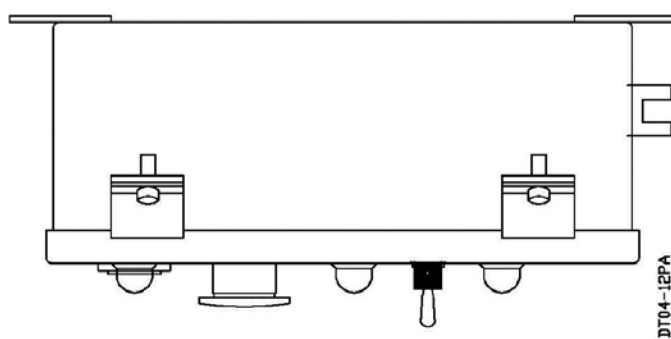
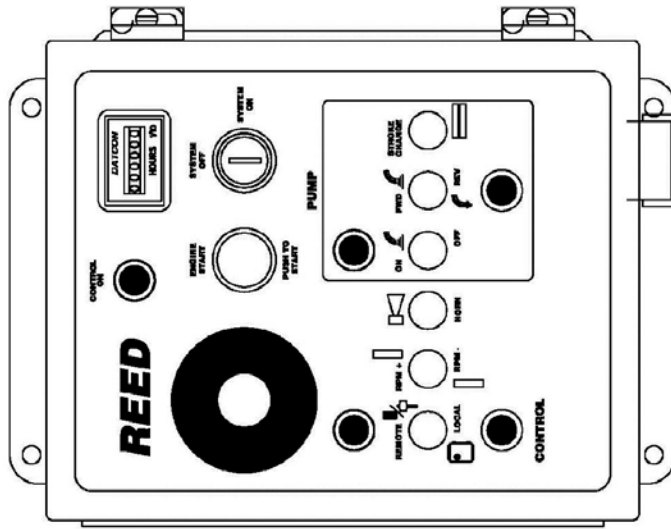

CONNECTOR P2: 12 PIN DEUTSCH DT04-12PA

PIN#	DESCRIPTION
1	REMOTE POWER
2	REMOTE GROUND
3	ENGINE RPM DECREASE INPUT
4	ENGINE RPM INCREASE INPUT
5	HORN INPUT
6	PUMP ON INPUT
7	PUMP REVERSE INPUT
8	PUMP STROKE CHANGE INPUT
9	REMOTE POWER RETURN
10-12	N/C

**CUSTOMER APPROVAL
APPROVED BY: _____
DATE: _____**

CONNECTOR P1: 24 PIN DEUTSCH DRC12-24PA

PIN#	DESCRIPTION
1	BATTERY POWER (12 VDC)
2	IGNITION POWER OUT
3	STARTER RELAY OUT
4	SAFETY JUMPS OUTPUT
5	FUEL PUMP OUTPUT
6	PUMP COIL A OUTPUT
7	PUMP COIL B OUTPUT
8	HORN SWITCH POWER
9	PROX SWITCH HEAD INPUT
10	PROX SWITCH BOD INPUT
11	ENGINE RPM MOTOR A OUTPUT
12	ENGINE RPM MOTOR B OUTPUT
13	REVERSE VALVE OUTPUT
14	REVERSE VALVE OUTPUT
15	GRATE SENSOR POWER
16	GRATE SENSOR POWER
17	GROUND
18	GROUND
19	GROUND
20	GROUND
21	GROUND
22	GROUND
23	CONTROLLER GROUND
24	CONTROLLER GROUND

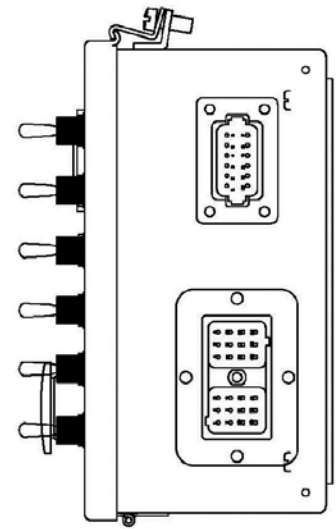

REV#	DATE	DESCRIPTION
00		NOT SCALE PRINT
01		SCALE PRINT
02		SCALE PRINT
03		SCALE PRINT
04		SCALE PRINT
05		SCALE PRINT
06		SCALE PRINT
07		SCALE PRINT
08		SCALE PRINT
09		SCALE PRINT
10		SCALE PRINT
11		SCALE PRINT
12		SCALE PRINT
13		SCALE PRINT
14		SCALE PRINT
15		SCALE PRINT
16		SCALE PRINT
17		SCALE PRINT
18		SCALE PRINT
19		SCALE PRINT
20		SCALE PRINT
21		SCALE PRINT
22		SCALE PRINT
23		SCALE PRINT
24		SCALE PRINT

REV: HCU/REED

DATE	TIME	BY	CHK	APP	REVISED MANUALLY	SCALE	REV	DATE	BY
KAR-TECH Delafield, WI 53018 CONCRETE PUMP CONTROL									
DATE	TIME	BY	CHK	APP	REVISED MANUALLY	SCALE	REV	DATE	BY

41-028-2-F-2A

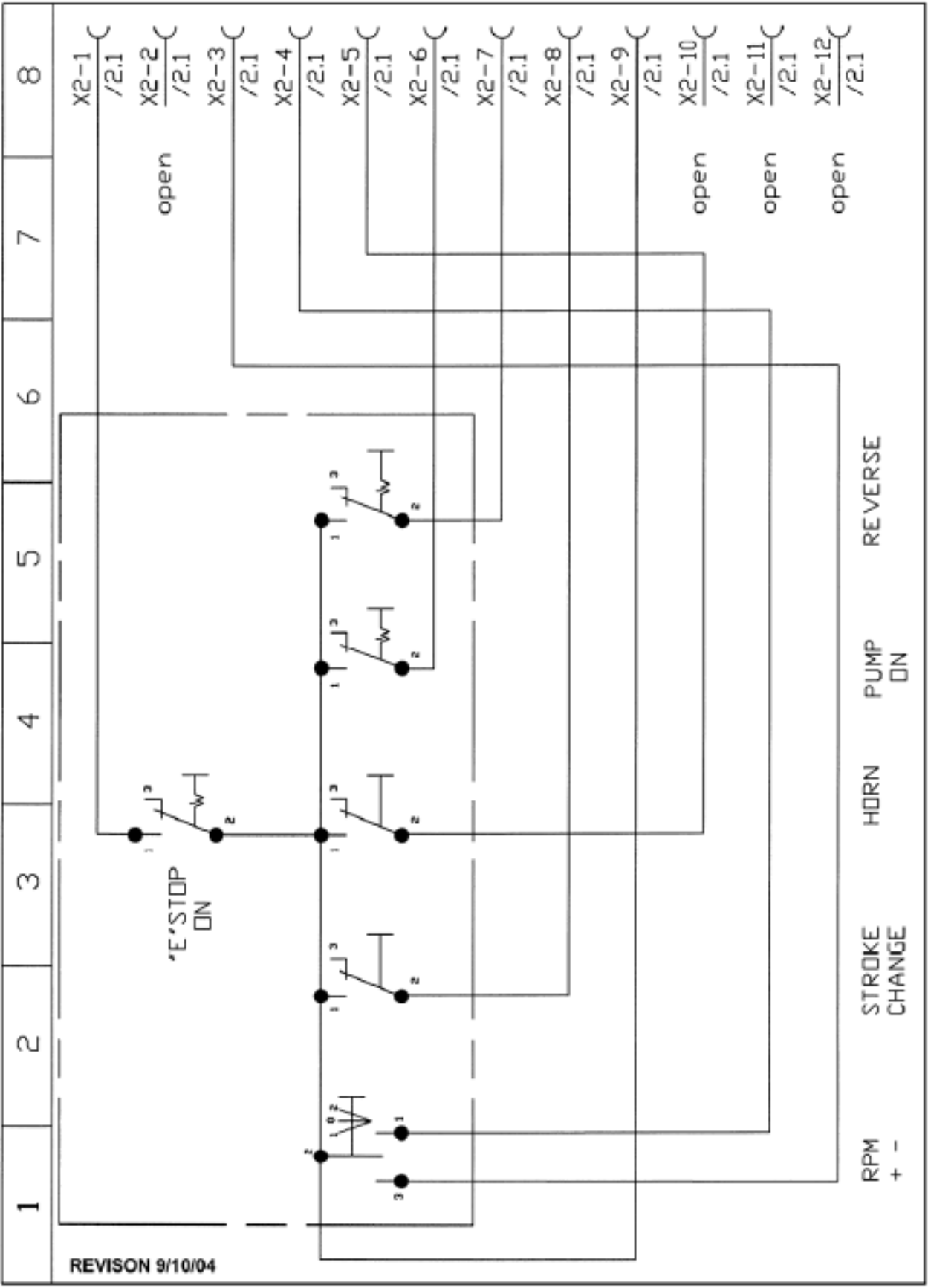

DEUSCH CONNECTOR PARTS
 PLUG BW10145
 BOOT BW10146
 PINS BW10147

24 PIN WIRE
 PLUG NUMBERS
 X1

- #20
- + #8
- #13
- + #1
- #12
- + #19
- #14
- + #8
- #18
- + #7
- #4
- + #15
- #11
- + #9
- #21
- + #10
- #16
- + #17
- #1
- + #2
- #3
- + #23
- #24
- + #22
- #5

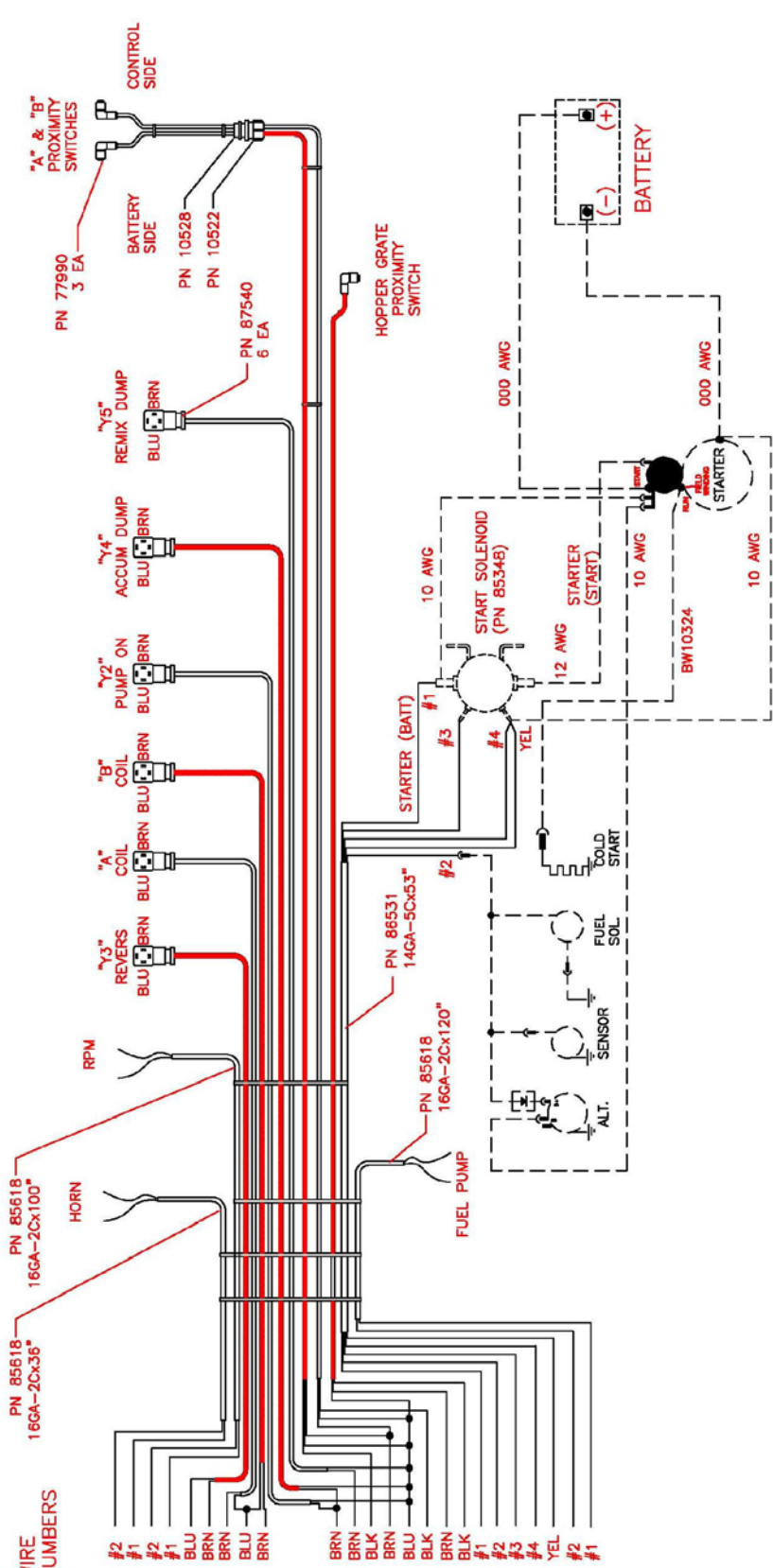

DO NOT SCALE DRAWING		CONCRETE PLACING EQUIPMENT	
UNLESS OTHERWISE SPECIFIED, DIMENSIONS ARE IN INCHES.		CHINO, CA 91710	
TOLERANCES: XX .030 XXX .010		TITLE REED WIRING HARNESS, A SER, BW10039-2	
FRACTION 1/32		MATERIAL	
ANGLE 1/2		PART NUMBER	
DRAWN SK		REV	
BY		BW10414	
DATE		SHEET 1 OF 1	
DESCRIPTION OF CHANGE		THIS DRAWING IS THE PROPERTY OF REED MANUFACTURING AND IS TO BE USED ONLY FOR THE EQUIPMENT SPECIFIED IN THE ORIGINAL AGREEMENT THAT IT SHALL NOT BE REPRODUCED, LOANED, OR DISPOSED OF, DIRECTLY OR INDIRECTLY, NOR USED FOR ANY PURPOSE OTHER THAN THAT FOR WHICH IT IS SPECIFICALLY FURNISHED.	
REVISIONS			

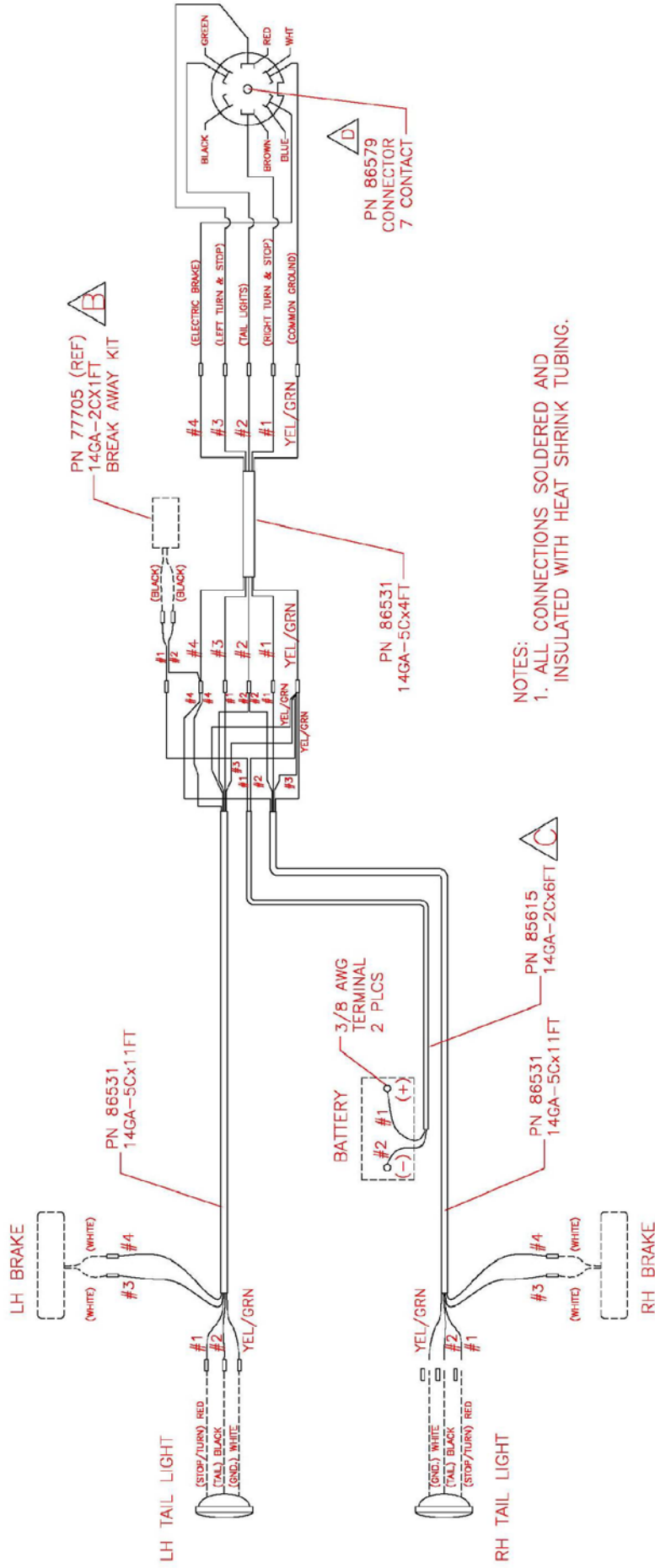

NOTES:
 1. ALL CONNECTIONS SOLDERED AND INSULATED WITH HEAT SHRINK TUBING.

DO NOT SCALE DRAWING		CONCRETE PLACING EQUIPMENT	
UNLESS OTHERWISE SPECIFIED, DIMENSIONS ARE IN INCHES.		CHINO, CA 91710	
SK	ECN#12000	TITLE	REED
HR	ECN#596	TITLE	TRAILER HARNESS, A SERIES
HR	ECN#536	MATERIAL	
HR	ECN#490	THIS DRAWING IS THE PROPERTY OF REED MANUFACTURING AND IS LOANED WITHOUT CONSIDERATION OTHER THAN THE BORROWER'S AGREEMENT THAT IT SHALL NOT BE REPRODUCED, COPIED, LOANED, OR USED IN ANY MANNER OTHER THAN THAT FOR WHICH IT IS SPECIFICALLY FURNISHED.	PART NUMBER BW10139
REV	DATE	DESCRIPTION OF CHANGE	REV
A	03/12/02		D
REVISIONS		SHEET 1 OF 1	

APPLICATION NOTES:

The following connections are made through the REED Interface Cable, p/n HAR4002.

1. Remote Power Return

The system will provide a +12Vdc signal on pin 9 of the Reed connector when the remote handheld unit is turned ON.

2. Pump On/Off

The system provides a +12Vdc signal on pin 6 of the Reed connector when the remote Pump On button is pressed. When the Pump Off button on the remote is pressed, the +12Vdc signal is removed.

3. Pump Forward/Reverse

The system provides a latched +12Vdc signal on pin 7 when the Reverse button is pressed. When the Forward button is pressed, the +12Vdc signal is removed.

4. Engine Throttle

A +12Vdc voltage will be present (momentary operation) between pins 3 and 4 of the Reed connector when the Throttle Up button is pressed.
A negative 12Vdc voltage will be present on these same pins when the Throttle Down button is pressed.

5. Pump Stroke Change

A momentary +12Vdc signal will be placed on pin 8 of the Reed connector when the Volume Up button is pressed.

6. Horn

A momentary +12Vdc signal will be placed on pin 5 of the Reed connector when the Horn button is pressed.

7. Power Connections

System power must be provided through a keyed and fused +12VDC power source. The system must be fused with a 10 amp fuse.
The receiver must also be connected to a suitable electrical ground. These connections are made through the pins 1 and 2 of the Reed connector respectively.

8. Antenna Connection

Mount the antenna to the top side of the concrete pumper cowling. Connect the antenna to the receiver using the supplied 5 foot coax cable.
Using cable ties, affix the cable to suitable locations to prevent flexing due to vibration. Excessive flexing can cause the internal conductor to suffer fatigue and break.

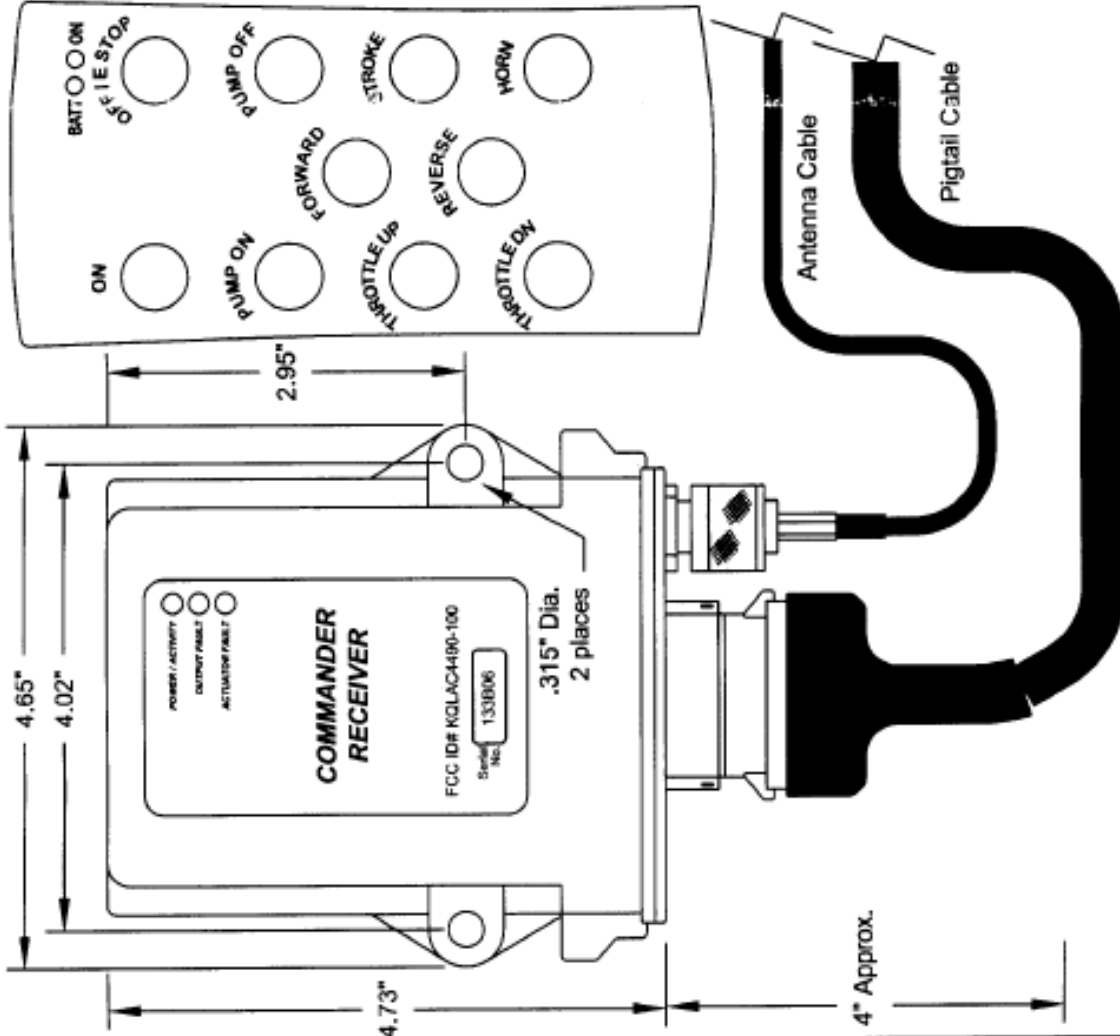

Title Concrete Pumper System REED Series A Type		
Size A	Number 20030	Rev 3
Date October 24, 2008	Drawn By MGS	
Filename 20030Ar3.dwg		
Sheet 1 of 4		

REED Series A Controller Unit

For specific detail on the connections to the Series A controller, please consult REED drawing No. 41-028-6-A and the table below.

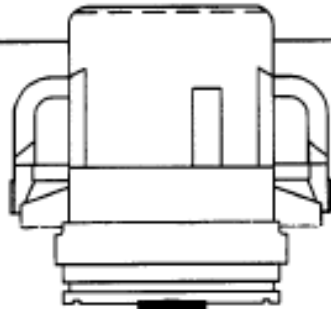

REED Controller Connector



Interface Cable from BASE Receiver

SYSTEM CONNECTION

Base Pin #	Colour	Base Function	Reed Pin #	Reed Function
1	Blue	CH4 Output	9	Remote to Power Return
2	White	CH3 Output	5	Horn
3	Green	CH2 Output	7	Pump Reverse
4	Black/White	RS232 TX	N/C	-
5	Blue/Black	RS232 RX	N/C	-
6	Red	V/Batt (Power In)	1	Remote Power
7	Green/Black	Bridge Output 2-1	8	Pump Stroke Change
8	Orange/Black	Bridge Output 2-2	N/C	-
9	Red/Black	Bridge Output 1-2	3	Throttle Down
10	White/Black	Bridge Output 1-1	4	Throttle Up
11	Orange	CH1 Output	6	Pump On
12	Black	GND	2	Remote GND

BASE ENGINEERING INC.
WIRELESS INDUSTRIAL CONTROLS

Title Concrete Pumper System
REED Series A Type

Size A Number 20030 Rev 3

Date October 24, 2008 Drawn By MGS

Filename 20030Br3.dwg Sheet 2 of 4



A40HP PARTS

13822 Oaks Avenue
Chino, CA 91710
reedpumps.com
909-287-2100

PUMPING TRAIN ASSEMBLY	2
5" OUTLET ASSEMBLY	4
5" OUTLET SEAL KIT INSTALLATION	5
WEAR PLATE ASSEMBLY	6
6" PISTON CUP ASSEMBLY	7
DRIVE CYLINDER ASSEMBLY	8
SINGLE SHIFT BELL CRANK ASSEMBLY.....	9
SINGLE SHIFT SWING CYLINDER ASSEMBLY	10
HOPPER GRATE WITH SAFETY SWITCH.....	11
GRATE ASSEMBLY	12
CLEAN OUT DOOR ASSEMBLY	13
POWER TRAIN.....	14
ENGINE, PUMPS, AND FILTERS	14
ENGINE MOUNTS.....	17
HYDRAULIC LINES, HOSES, AND FITTINGS	21
CONTROL MANIFOLD	26
SOLENIOD VALVE ASSEMBLIES	31
ELECTRICAL GROUP	32
BATTERY.....	32
PROXIMITY SWITCHES	33
STARTER RELAY.....	34
TRAILER HARNESS AND BREAKAWAY	35
TAILLIGHTS.....	36
WIRING HARNESS	37
A-SERIES CONTROL BOX	38
CONTACT BLOCKS	40
FUSES AND RELAYS	41
CONNECTORS.....	42
50FT CABLE REMOTE	43
FRAME INSTALLATION.....	44
FRAME, GAUGES, TIRES, JACK, AND TOW EYE.....	44
5200LB AXLE MOUNTING ASSEMBLY	45
HOOD AND COVERS.....	46
FENDERS AND OUTRIGGERS	47
OPTIONS.....	48
MANUAL OUTRIGGERS	48
HYDRAULIC AGITATOR.....	49
AUTOLUBE PUMP (PLASTIC TUBING)	52
RADIO REMOTE KIT (BASE).....	54
CHROME WHEEL AND TIRE	55
SURGE BRAKE ASSEMBLY.....	56

PUMPING TRAIN ASSEMBLY

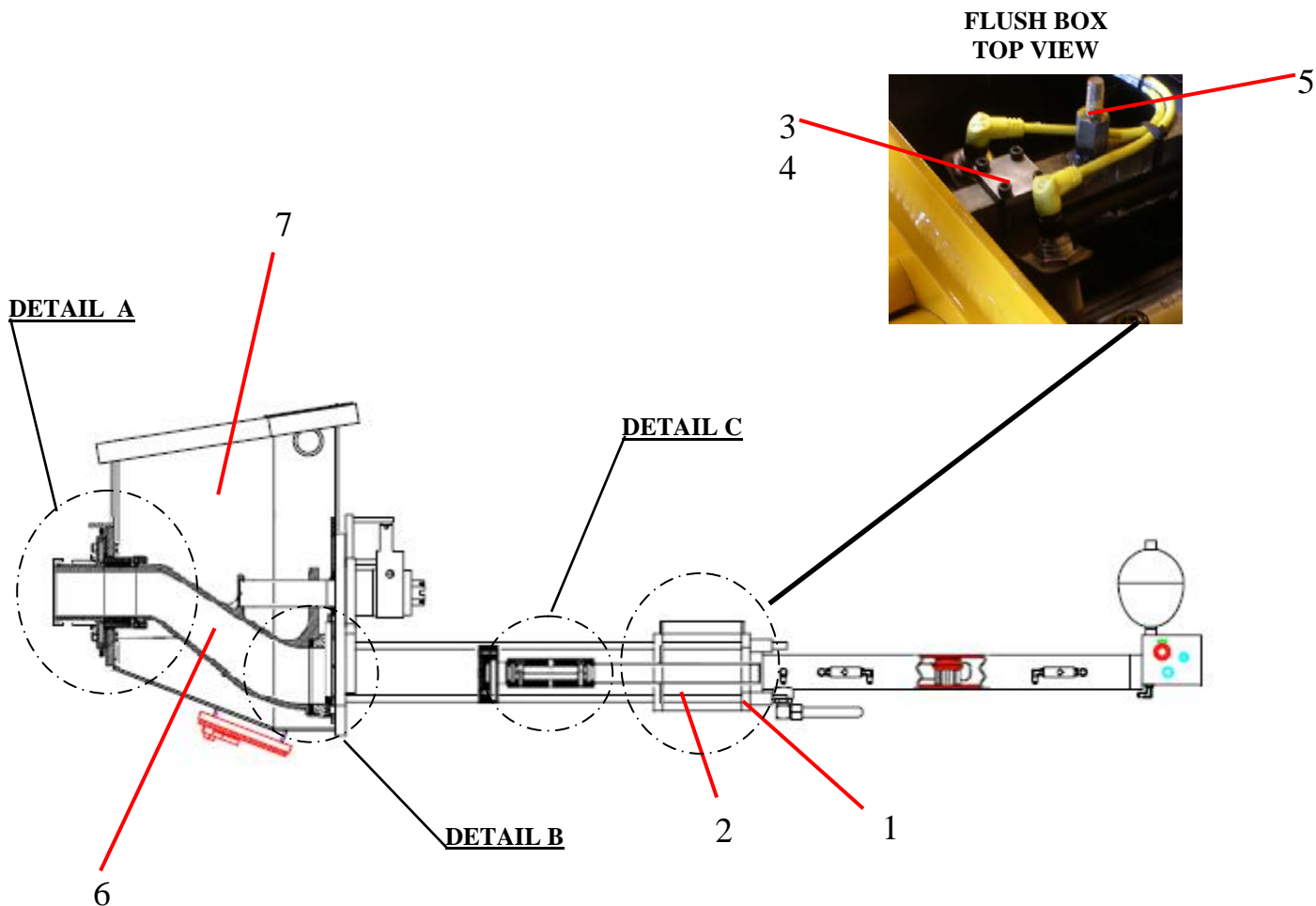

ID #	PART #	PART DESCRIPTION	QUANTITY	
	BW28045-5	PUMP CELL ASSEMBLY A40 W/SAFTY SWITCH, JARP-HYDATECH		REF
1	10282	PLUGS-PIPE GALV 1"	1	EA
2	BW10368	FLUSH BOX WELDMENT, A40	1	EA
3	BW10101	BRACKET, PROX SWITCH, A30	1	EA
4	BW10383	BRACKET, PROX SWITCH	1	EA
5	BW10193	STUD, 3/8-16 X 2" LONG	1	EA
6	BW10391	S TUBE WELDMENT, 6X5 A40	1	EA
7	BW10363A	HOPPER, WELDMENT A40 SAFETY SWITCH	1	EA

PUMPING TRAIN ASSEMBLY CONTINUED

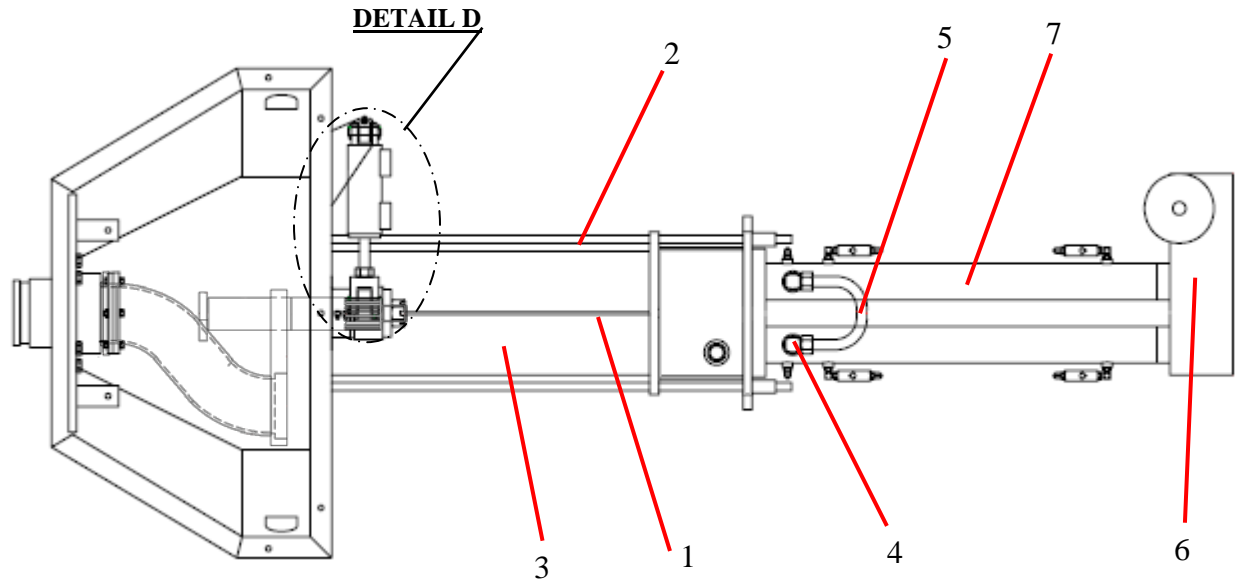

ID #	PART #	PART DESCRIPTION	QUANTITY	
1	BW10380	TIE ROD, SHORT, A40	4	EA
2	BW10381	TIE ROD, LONG, A40	2	EA
3	BW10376	CONCRETE CYLINDER, 6" X 30" A40	2	EA
4	86728-023	ELBOW, MB – MJ90-16-16	2	EA
5	BW10394	TUBE, HYD, LOOP LINE, A40	1	EA
6	BW10395	MANIFOLD CONTROL W/CARTRIDGES, A40	1	EA
7	BW10373HT	DRIVE CYLINDER 3.75 X 2.00 X 30.00 (HYDRATECH))	REF	

S-TUBE ASSEMBLY
5" OUTLET ASSEMBLY

DETAIL A

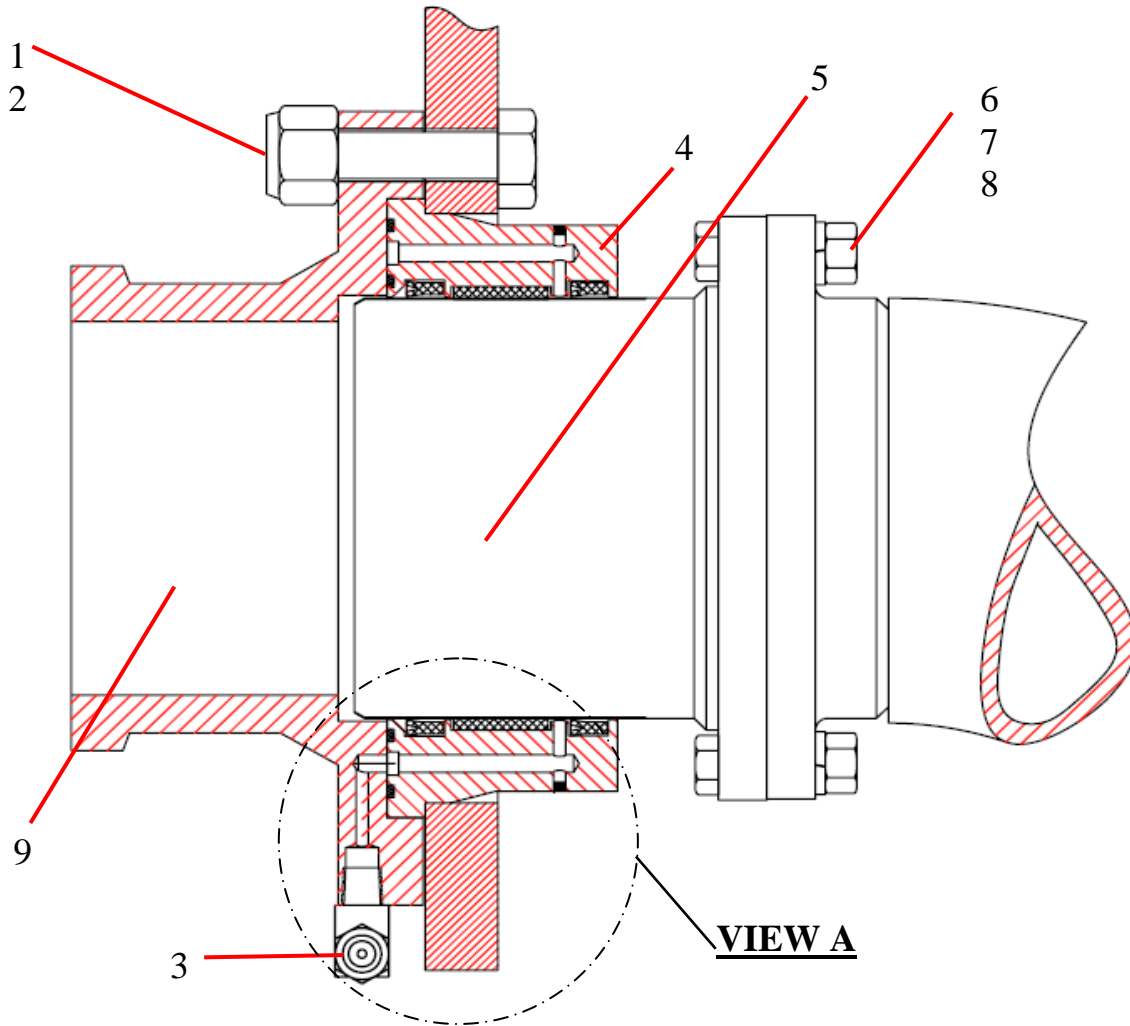

ID #	PART #	PART DESCRIPTION	QUANTITY	
	86321	OUTLET ASSEMBLY	1	EA
1		HHCS, 5/8-18 x 3" GR/8	6	EA
2		LOCK NUT, 5/8-18	6	EA
3		GREASE FITTING, 1/8" NPT 90°	2	EA
4	72309	OUTLET SEAL HOUSING	1	EA
5	70042	WELD.-CHROMED OUTLET	1	EA
6		HHCS, 3/8 - 16 X1 1/2" GR 8	6	EA
7		HEX NUT, 3/8" - 16	6	EA
8		LOCK WASHER, 3/8"	6	EA
9	72482	OUTLET, 5" (1-PIECE)	1	EA

5" OUTLET SEAL KIT INSTALLATION

VIEW A

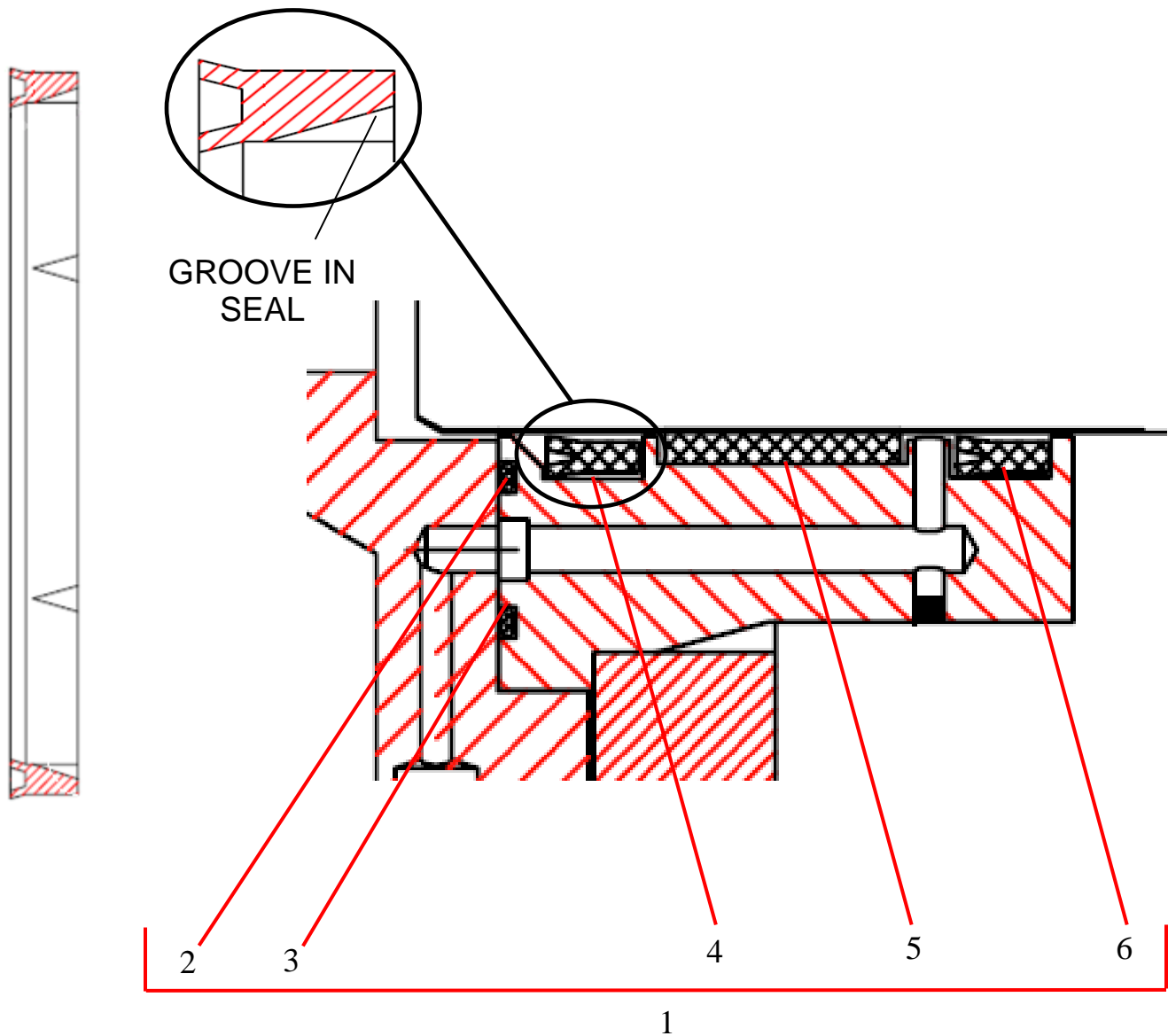

ID #	PART #	PART DESCRIPTION	QUANTITY	
1	79895	SEAL KIT	1	EA
2	77762	O-RING-#257 BUNA 90	1	EA
3	77761	O-RING-#264 BUNA 90	1	EA
4	86504	SEAL-MODIFIED- 5 IN OUTLET	1	EA
5	77763	GUIDE BAND – 5.375 OD X 1.00W	1	EA
6	77765	LIP SEAL -5.50 ID X 6.00 OD X.56	1	EA

WEAR PLATE ASSEMBLY

DETAIL B

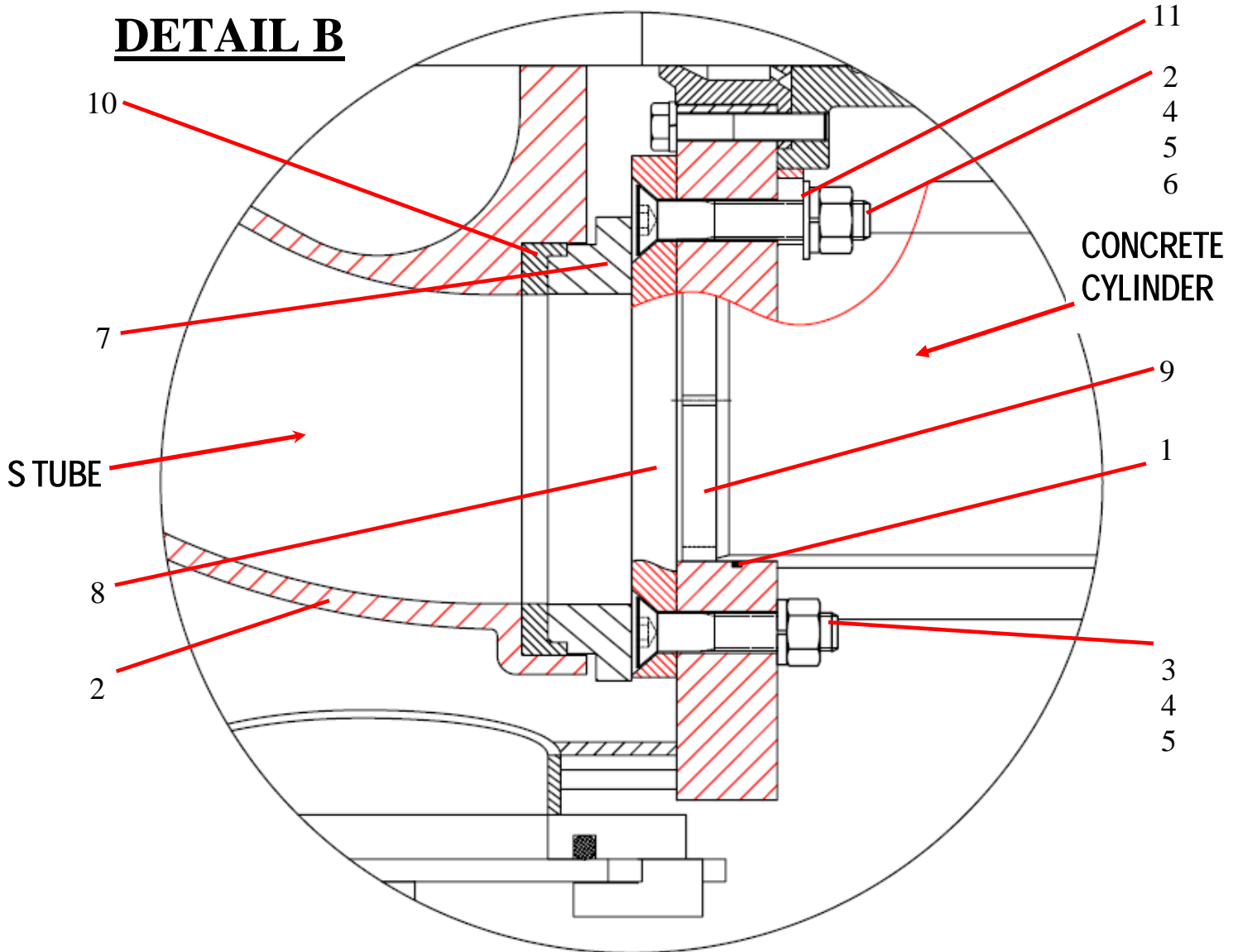

ID #	PART #	PART DESCRIPTION	QUANTITY	
1	86149	O-RING, #259 BUENA 70	1	EA
2		FHCS, 3/4" - 10X 4 1/2" GR 8	1	EA
3		FHCS, 3/4" - 10X 3 1/2" GR 8	3	EA
4		HEX NUT, 3/4" - 10	4	EA
5		LOCK WASHER, 3/4"	4	EA
6		FLATWASHER, 3/4"	4	EA
7	72310	WEAR RING, 6"	1	EA
8	BW10382	WEAR PLATE 6" A40	1	EA
9	86086	CHIP RING, 6"	2	EA
10	86085	SEAL, SINGLE LIP, 6"	1	EA
11	86502	LOCATOR RING - FLANGE BEARING	1	EA

6" PISTON CUP ASSEMBLY

DETAIL C

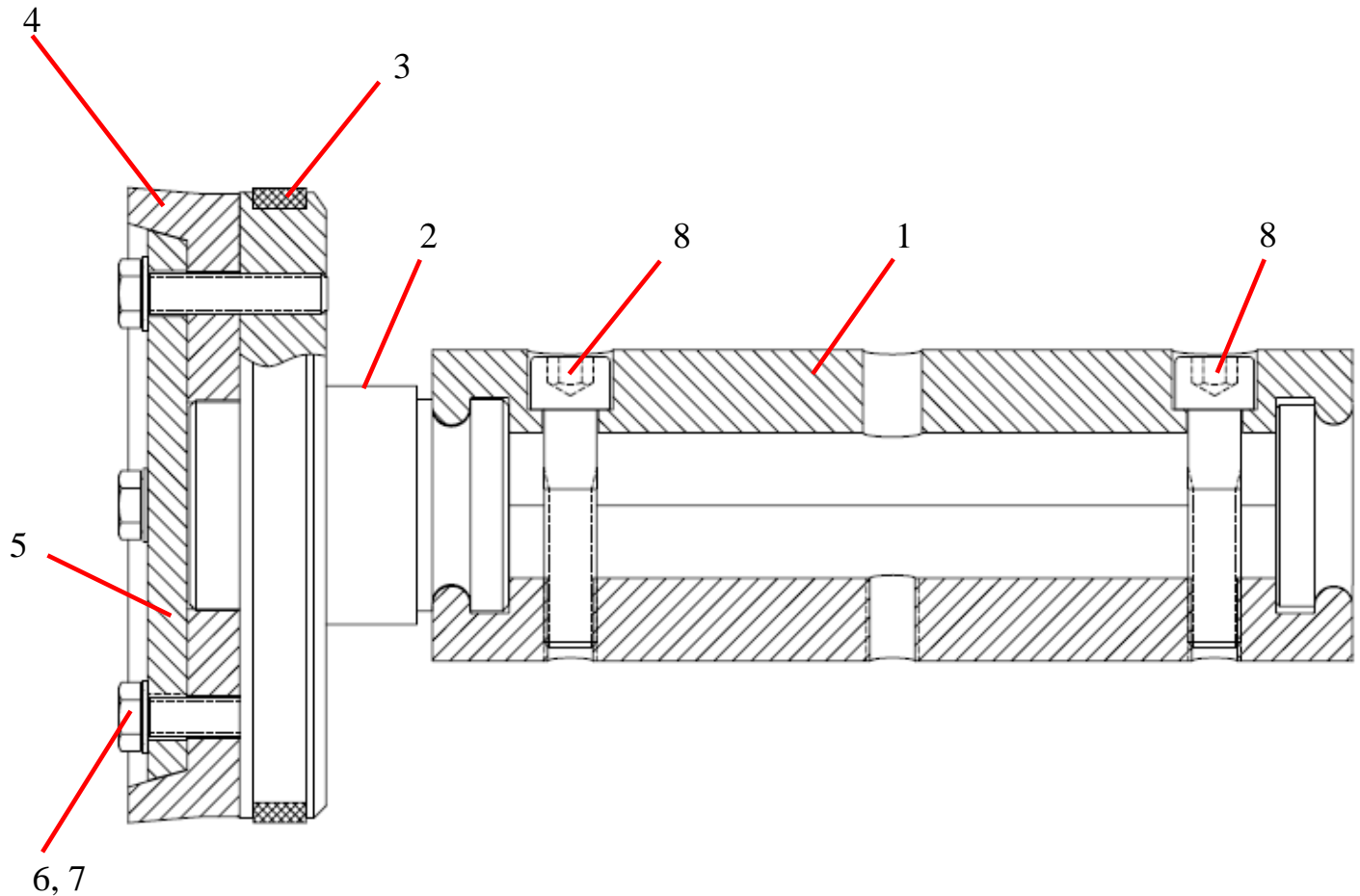

ID #	PART #	PART DESCRIPTION	QUANTITY	
1	73425	PISTON COUPLING	1	E/SIDE
2	77194	PISTON ADAPTER 6"	1	E/SIDE
3	77120	WEAR RING (GUIDE BAND) 6"	1	E/SIDE
4	70048	PISTON CUP, 6 IN.	1	E/SIDE
5	70057	PISTON PLATE 6"	1	E/SIDE
6		HHCS, 3/8-24 x1 3/4" GR 8	4	E/SIDE
7		INTERNAL LOCKWASHER 3/8	4	E/SIDE
8		SHCS 1/2 - 20 x 2 1/4"	2	E/SIDE

DRIVE CYLINDER ASSEMBLY

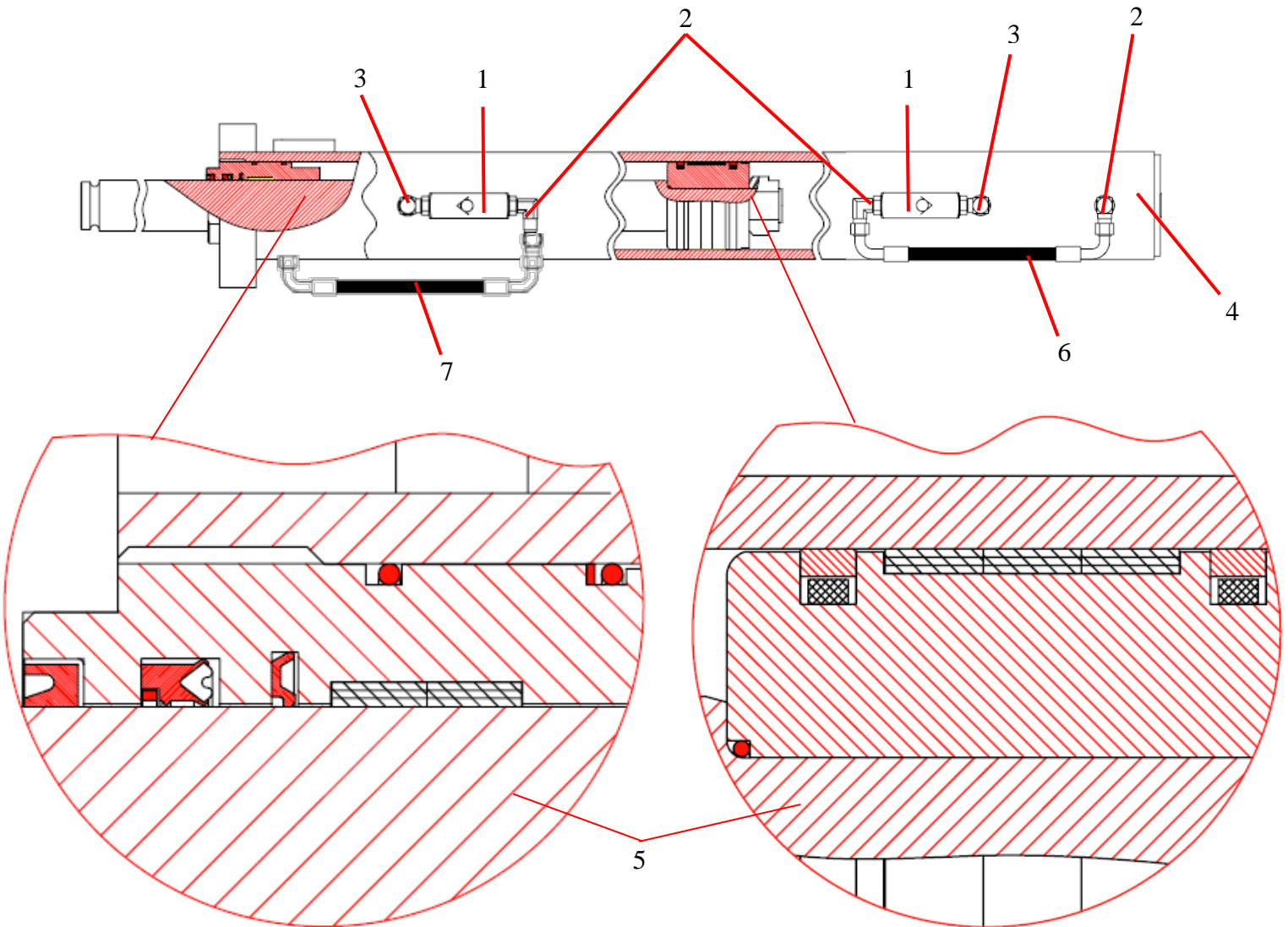

ID #	PART #	PART DESCRIPTION	QUANTITY	
1	78961	CHECK VALVE-5K PSI O-RING	2	EA/SIDE
2	86748	FITTING-MB-MJ90-6-6	3	EA/SIDE
3		ELBOW, MB-MB90-6-6	2	EA/SIDE
4	BW10373HT	DRIVE CYL-3.75 X 2.00 X 30.00 (HYDRATECH))	2	EA/SIDE
5	BW10373A-SK	SEAL KIT FOR BW10373HT CYL	2	EA/SIDE
6	BW10051	HOSE-RT2-FJS90-FJS09-06-06-06-12"	1	EA/SIDE
7	BW10405	HOSE-RT2-FJS90-FJS09-06-06-06-14"	1	EA/SIDE

SINGLE SHIFT BELL CRANK ASSEMBLY

DETAIL D

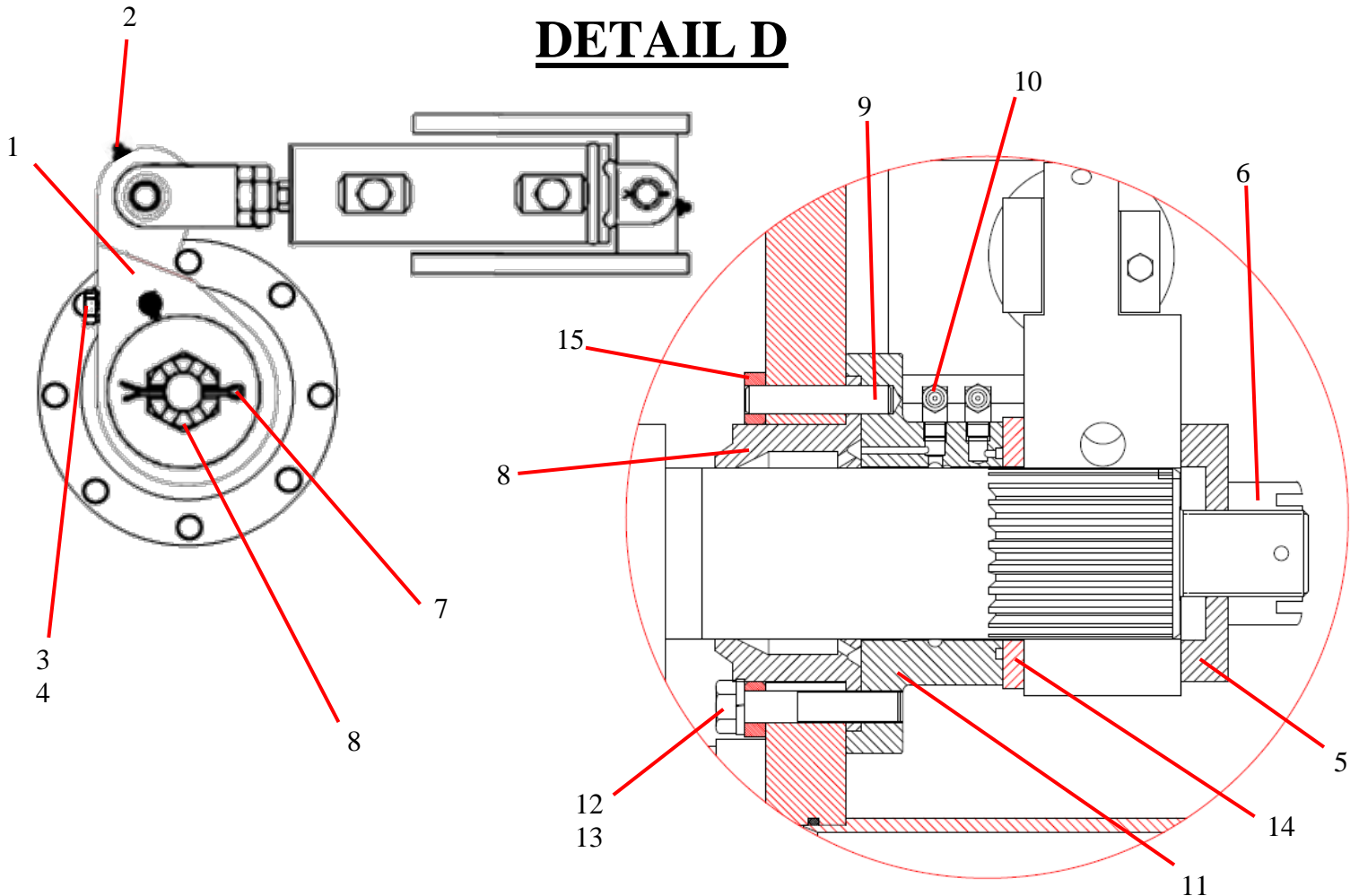

ID #	PART #	PART DESCRIPTION	QUANTITY	
1	85131	BELL CRANK, 3 IN SPLINE, SINGLE	1	EA
2		GREASE FITTING, 1/8" NPT 45°	1	EA
3		HHCS, 3/4 x 4" GR 8	1	EA
4		LOCK WASHER, 3/4"	1	EA
5	85134	SPACER, S-TUBE NUT	1	EA
6	70825	NUT 1 1/2" - 12 CASTLE	1	EA
7		COTTER PIN, 1/4 x 4"	1	EA
8	85962	SEAL, FLANGE BEARING, 3" SHAFT	1	EA
9		DOWEL PIN, 1/2" DIA x 2"	2	EA
10		GREASE FITTING, 1/8" NPT	2	EA
11	85133	FLANGED BEARING, 3 IN SPLINE	1	EA
12		HHCS, 9/16 - 12x3" GR 8	4	EA
13		LOCK WASHER, 9/16"	4	EA
14	85294-1	THRUST WASHER, S -TUBE (NYLON)	1	EA
15	BW10384	SPACER RING A40	1	EA

SINGLE SHIFT SWING CYLINDER ASSEMBLY

DETAIL D

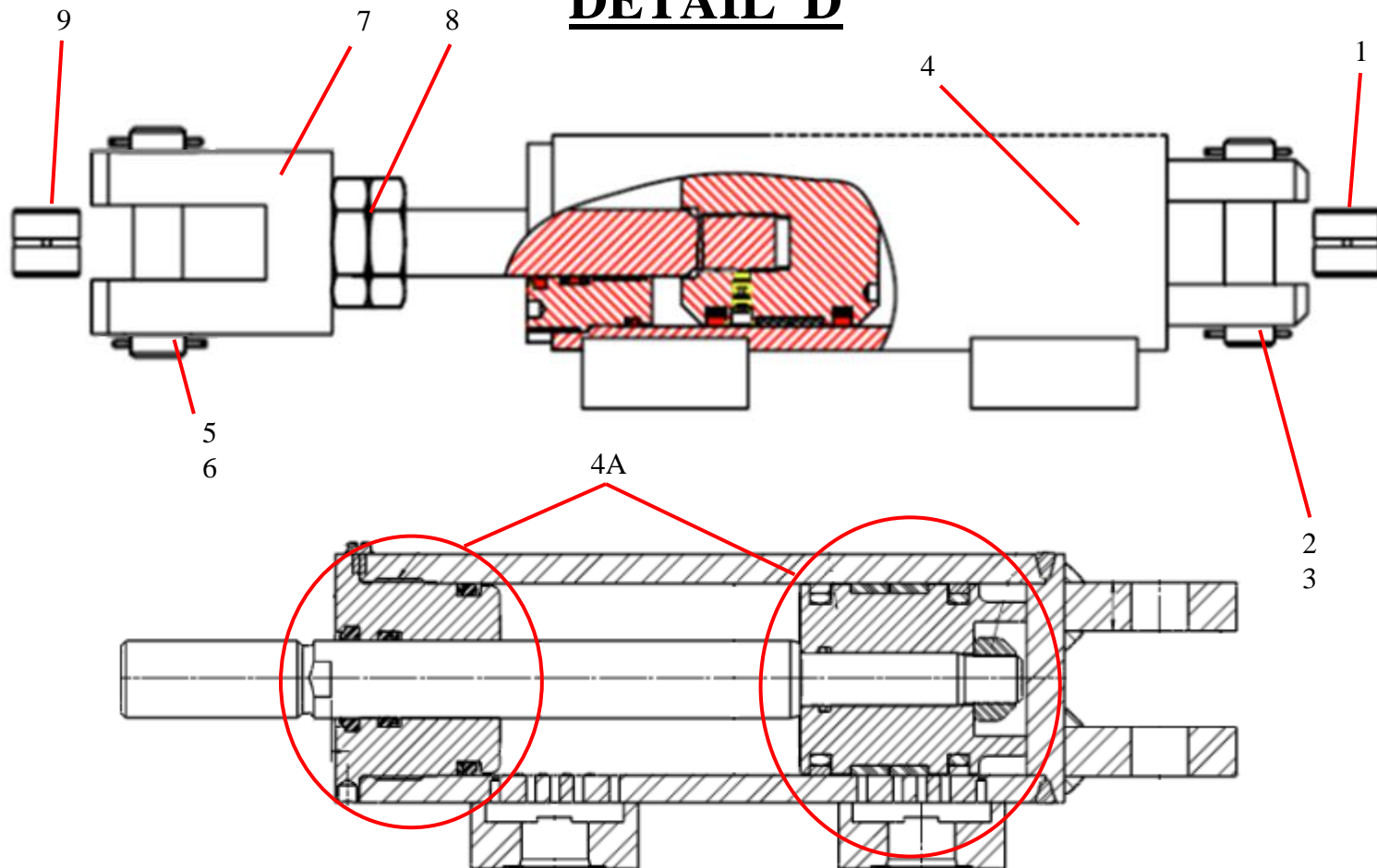

ID #	PART #	PART DESCRIPTION	QUANTITY	
1	71011	BUSHING - SHIFT CYLINDER	1	EA
2	74207	PIN - CLEVIS - .750 DIA	1	EA
3		COTTER PIN, 3/32X1 3/4"	2	EA
4	BW10374HT	SWING CYLINDER - 2.50 X 1.00 X 5.15	1	EA
4A	86221A-SK	SEAL KIT FOR BW10374HT	1	EA
5	86150	PIN, CLEVIS 1.00 DIA	1	EA
6		COTTER PIN, 1/8X2.00	2	EA
7	86135	CLEVIS, SHIFT CYLINDER	1	EA
8		1"X14 JAM NUT	2	EA
9	85538	BUSHING, SHIFT CYLINDER	1	EA

HOPPER GRATE WITH SAFETY SWITCH

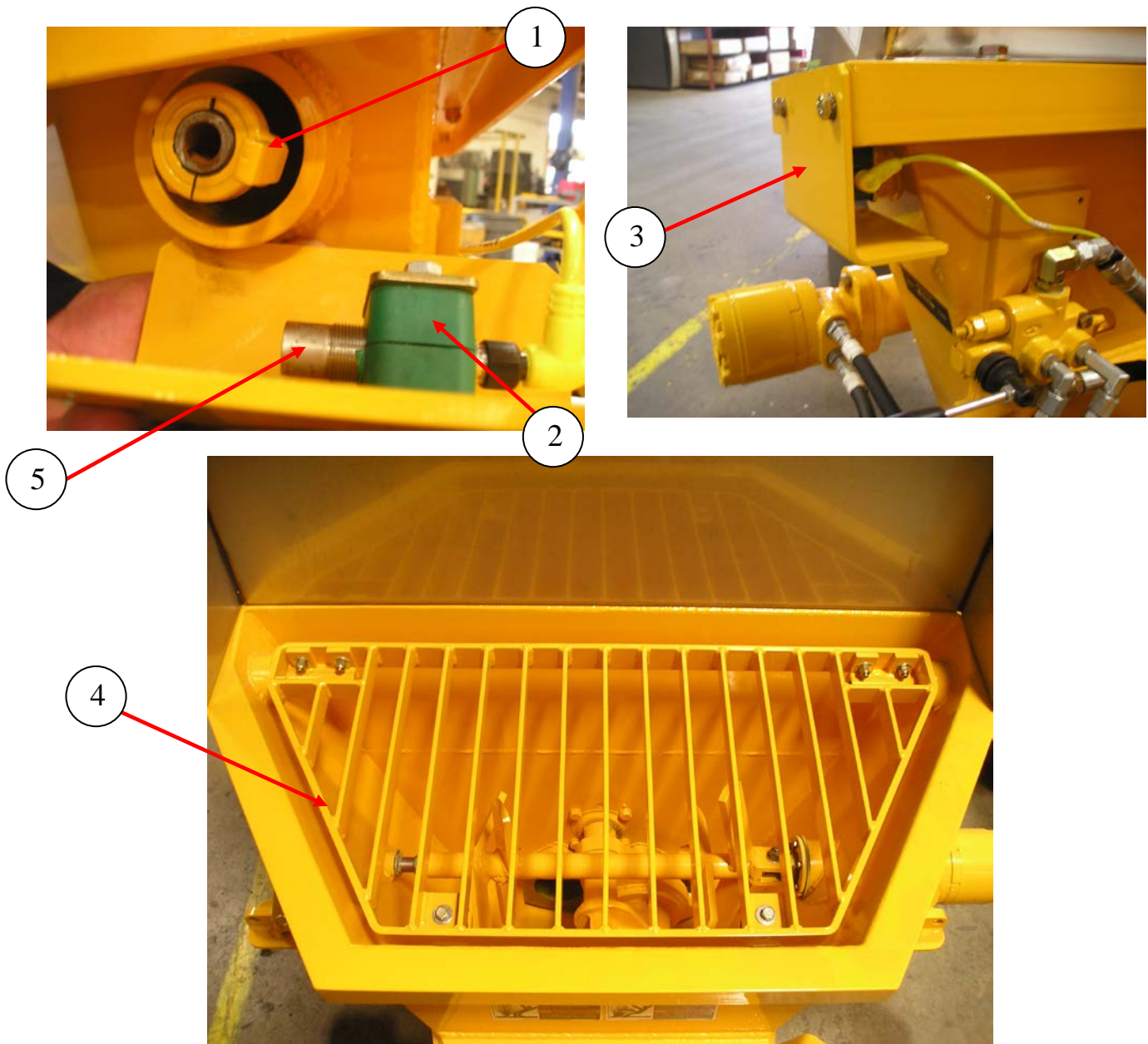

ID #	PART #	PART DESCRIPTION	QUANTITY	
1	87769	COLLAR SHAFT, 7/8" DIA	1	EA
2	801902-006	CLAMP, 18MM TUBE CLAMP SET	1	EA
3	87997	COVER WELD PROX SWITCH HOPPER	1	EA
4	BW10416	GRATE WELDMENT, A SER STD HOPPER	1	EA
5	87369	PROXIMITY SENSOR PMP	1	EA

GRATE ASSEMBLY

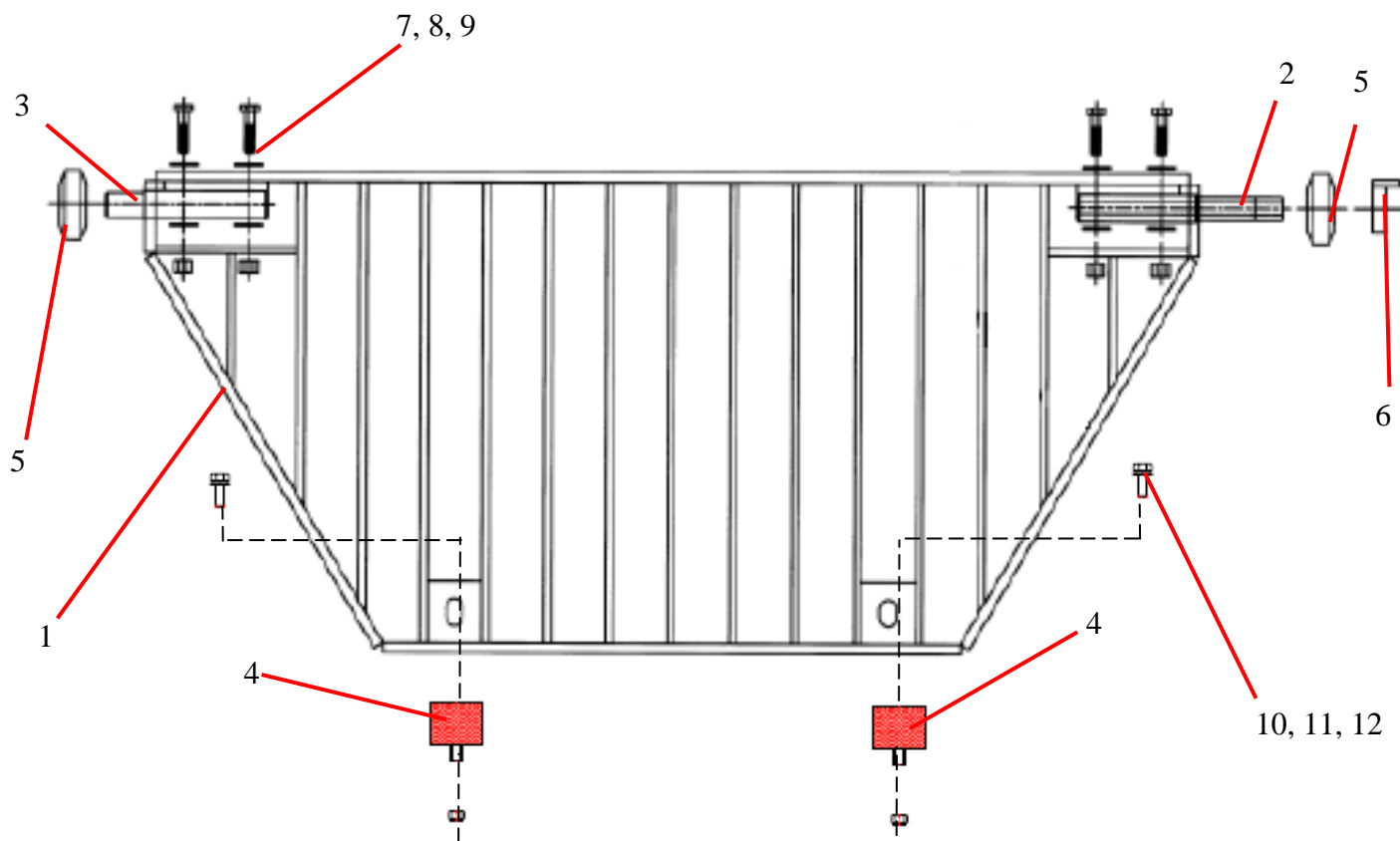

ID #	PART #	PART DESCRIPTION	QUANTITY	
1	BW10416	GRATE WELDMENT, A SER STD HOPPER		REF
2	87857	PIN WELDMENT LONG	1	EA
3	87858	PIN WELDMENT SHORT	1	EA
4	86083	BUMPER, HOPPER GRATE	2	EA
5	W-114850	RUBBER BUFFER 65X22.5X26	2	EA
6	87769	COLLAR SHAFT, 7/8" DIA	1	REF
7		3/8"-16 X 1 1/4" HEX BOLT	4	EA
8		3/8" FLAT WASHER	8	EA
9		3/8-16 LOCK NUT	4	EA
10		3/8"-16 X 1" HEX BOLT	2	EA
11		3/8" FLAT WASHER	2	EA
12		3/8" LOCK WASHER	2	EA

CLEAN OUT DOOR ASSEMBLY

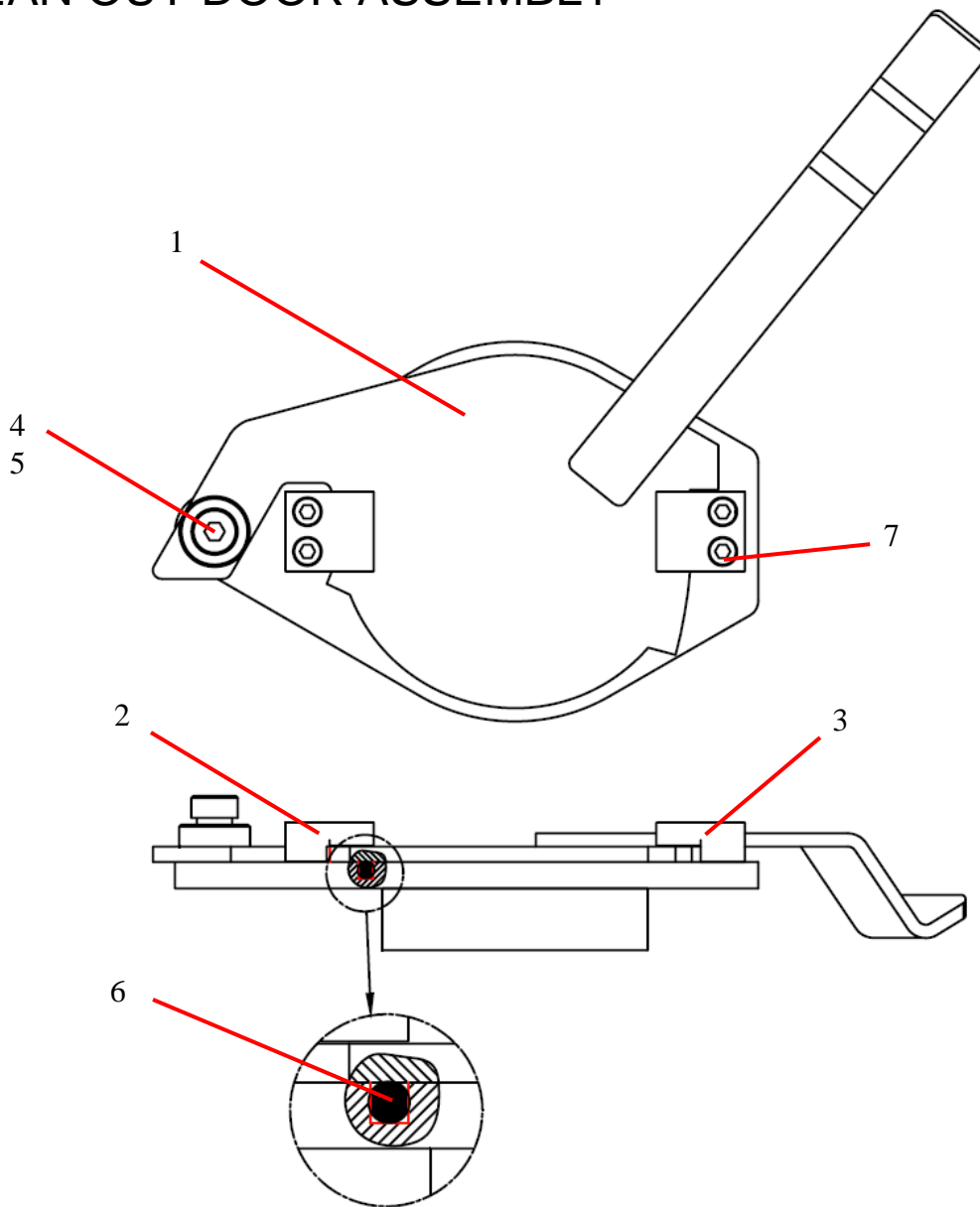

ID #	PART #	PART DESCRIPTION	QUANTITY	
1	85370	DOOR WELDMENT, CLEAN OUT	1	EA
2	86559	BLOCK, CLEAN OUT DOOR, LH	1	EA
3	86560	BLOCK, CLEAN OUT DOOR, RH	1	EA
4		SHOULDER SCREW 1" DIA-1 1/4"	1	EA
5	85367	BOSS, CLEAN OUT DOOR	1	EA
6	W102908A	O-RING CORD, HOPPER DOOR	2.21	FT
7		SHCS 1/2"-13 X 1 1/4"	4	EA

POWER TRAIN ENGINE, PUMPS, AND FILTERS

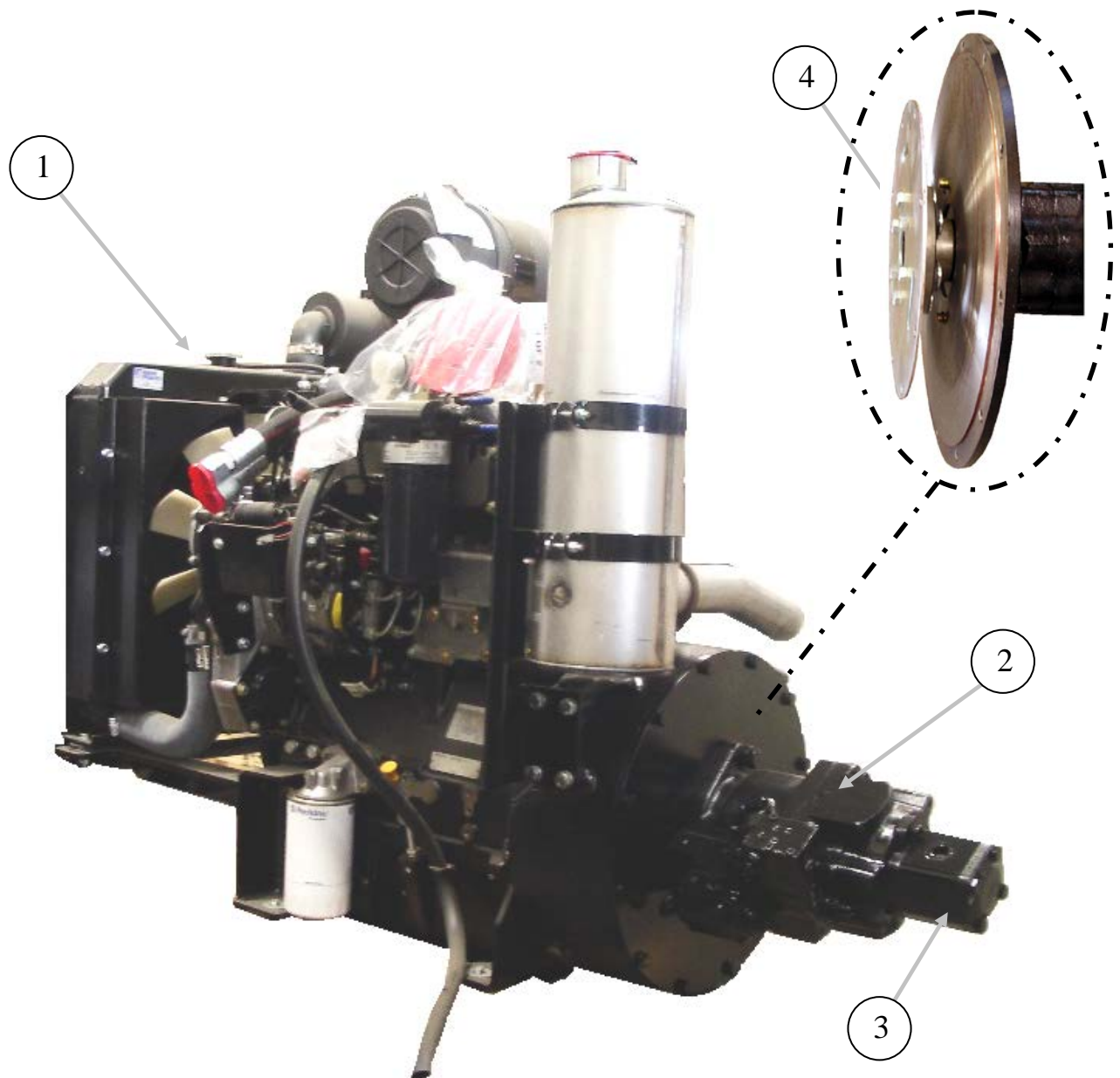

ID #	PART #	PART DESCRIPTION	QUANTITY	
	BW31051	POWER TRAIN ASSY. A40HP		REF
1	BW10039-2	ENGINE – PERKINS 1104D	1	EA
2	85124-004	PUMP, KV3L112 KAWASAKI, 75HP	1	EA
3	87153-001	PUMP-RH-DBLE GEAR, 11.3/8.2 CC	1	EA
4	87360	PUMP DRIVE -SAE 3 - SAE D	1	EA

ENGINE, PUMPS, AND FILTERS CONTINUED

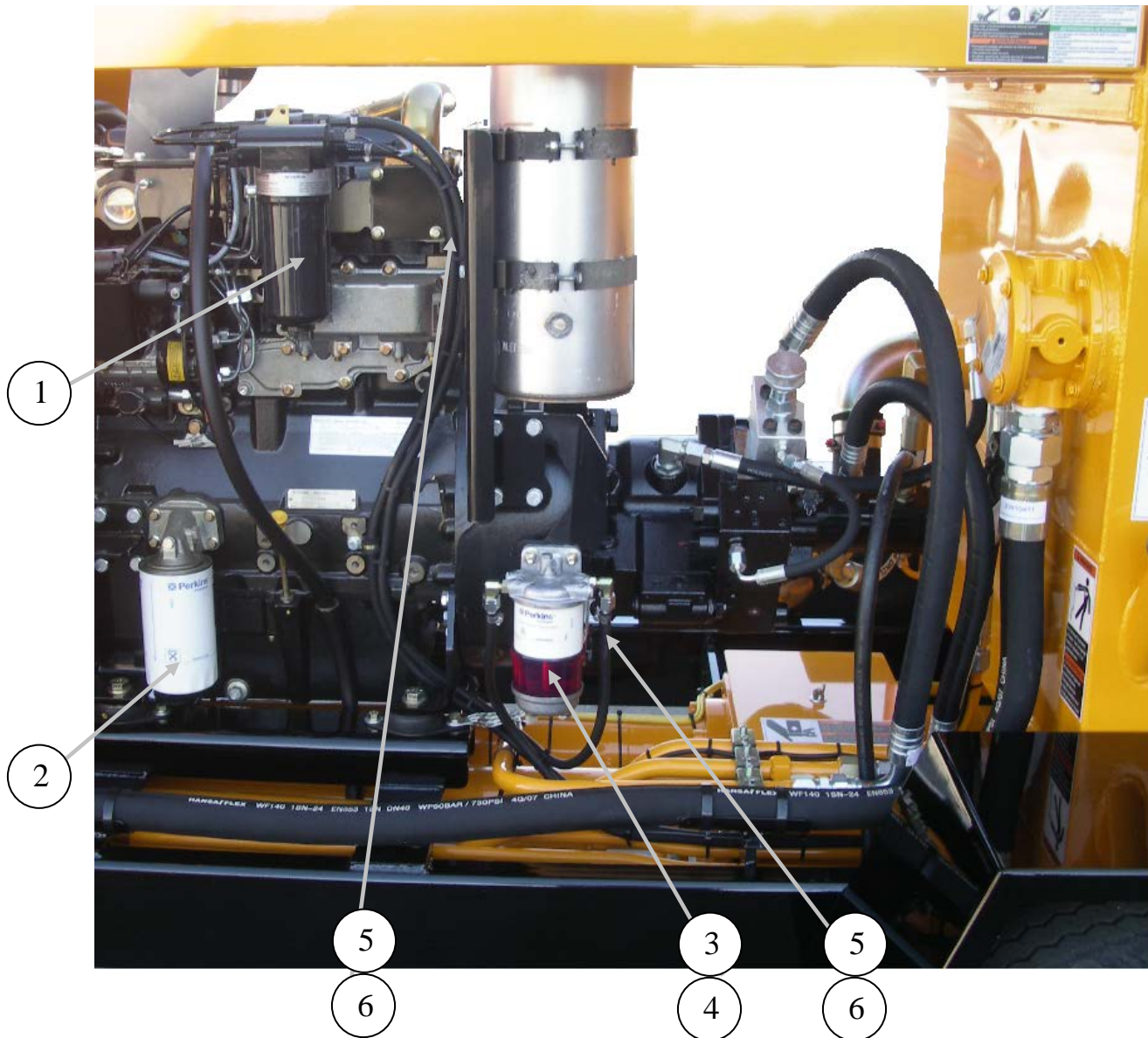

ID #	PART #	PART DESCRIPTION	QUANTITY	
1	BW10333	FILTER-FUEL PERKINS 1004-42 ENG	1	EA
2	BW10332	FILTER-OIL PERKINS 1004-42-ENG	1	EA
3	BW10451	WATER FUEL SEPERATOR	1	EA
4	BW10452	FILTER FOR FUEL- WATER SEP. (BW10451)	1	EA
5	77347A	HOSE- 5/16 SAE30R7 BLK (FUEL)	13	FT
6	10577	CLAMP-HOSE FOR 1/2" OD	6	EA

ENGINE, PUMPS, AND FILTERS CONTINUED

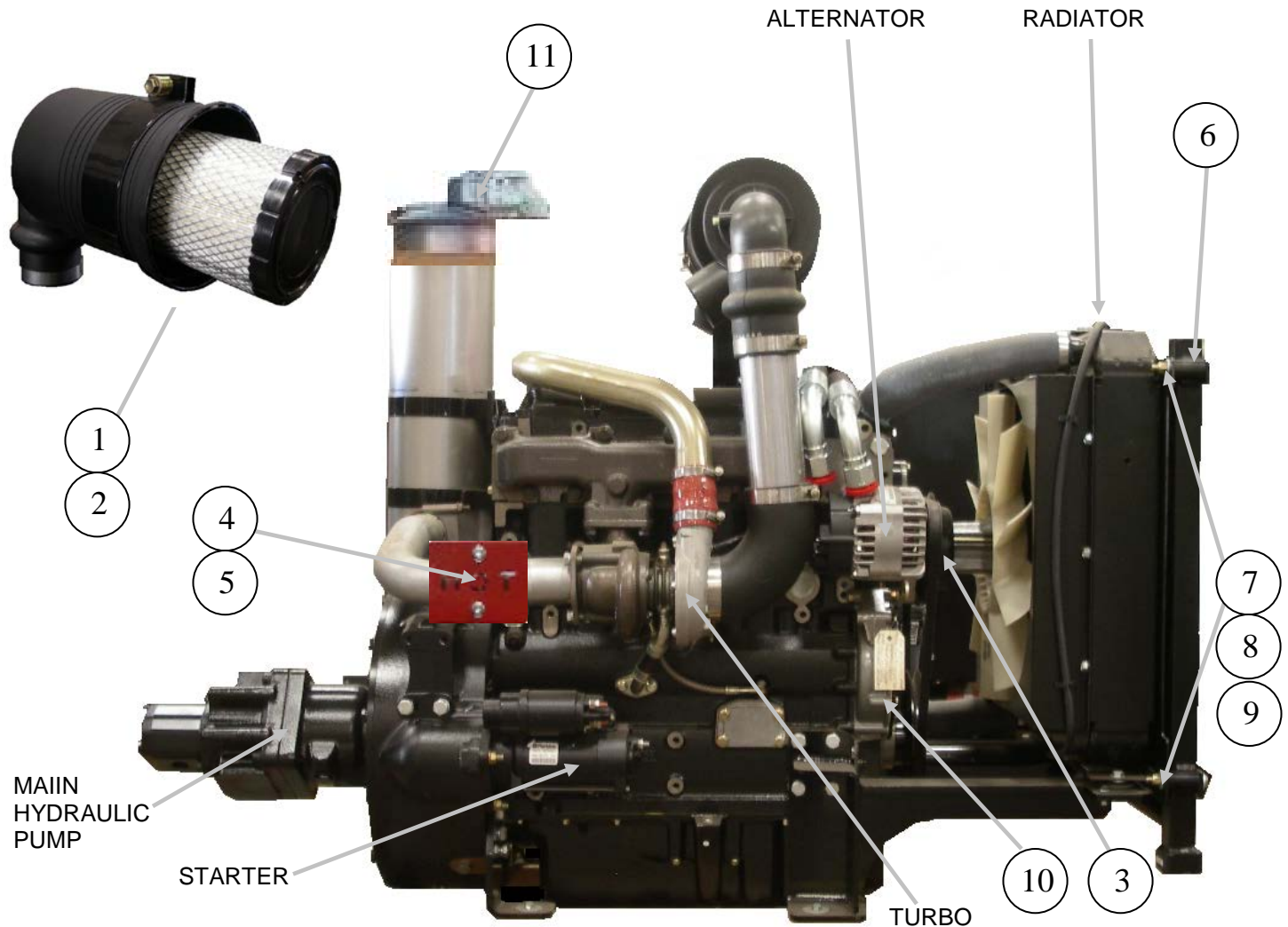

ID #	PART #	PART DESCRIPTION	QUANTITY	
1	BW10330	FILTER ELEMENT AIR, PRIMRY 1004C-ENGINE	1	EA
2	BW10331	FILTER ELEMENT AIR, SAFTY	1	EA
3	BW10334	FAN BELT	1	EA
4	BW10179	SAFETY PLATE, EXHAUST PAINTED RED	1	EA
5	78213	CLAMP	1	EA
6	BW10277	OIL COOLER-A30	1	EA
7	BW10289	SPACER, OIL COOLER, PAINTED (BLK)	4	EA
8	BW10289A	SPACER, OIL COOLER, PAINTED (BLK)	1	EA
9	BW10278	BRACKET-OIL COOLER, PAINTED BLK	2	EA
10	BW10335	WATER PUMP FOR BW10039-1-ENGINE	1	EA
11	70849	RAIN CAP, MUFFILER	1	EA

ENGINE MOUNTS

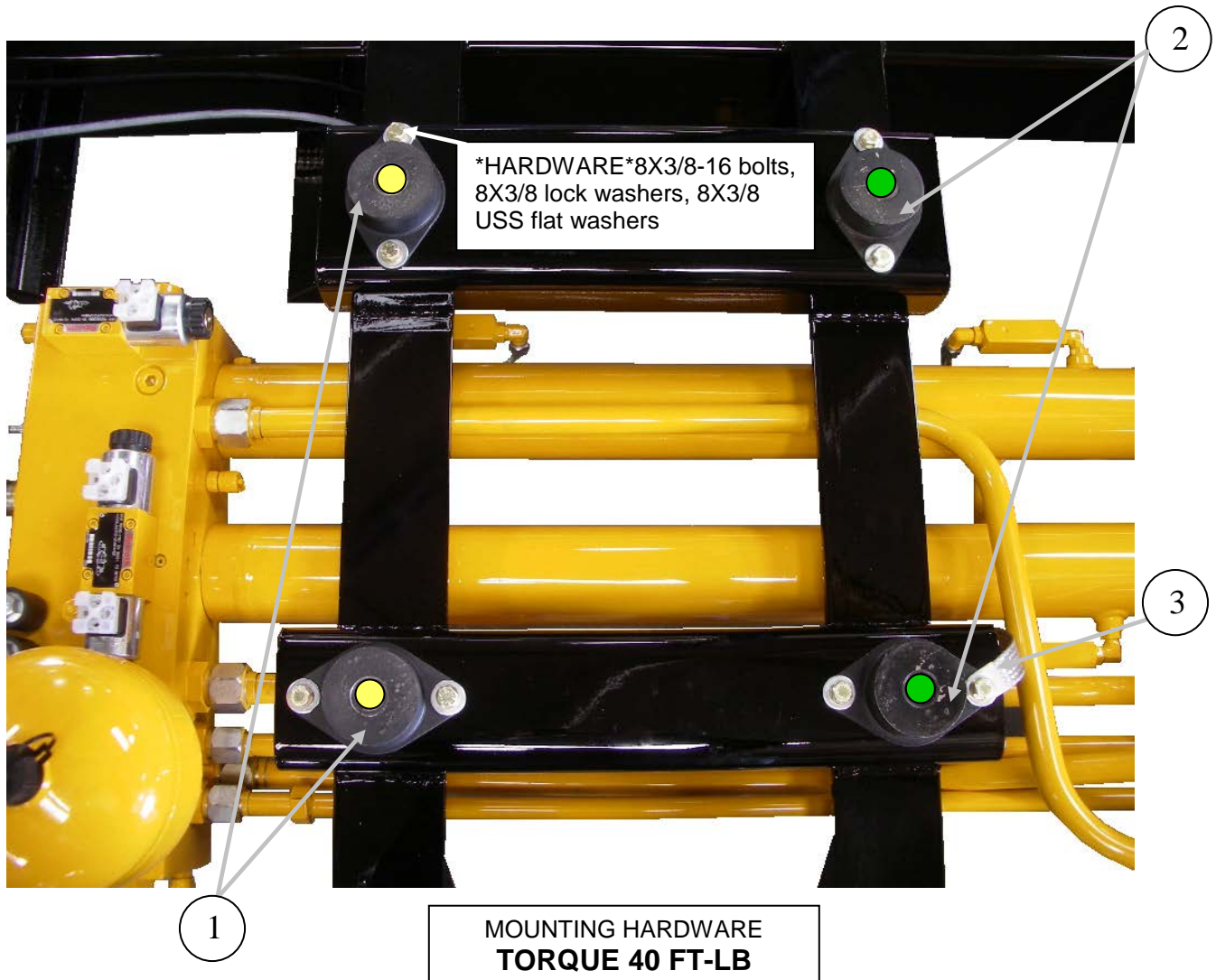

ID #	PART #	PART DESCRIPTION	QUANTITY	
1	BW10266	ENGINE MOUNT-FRT, 480 LB-YELLOW DOT	2	EA
2	BW10270	ENGINE MOUNT-REAR, 690 LB-GREEN DOT	2	EA
3	73269	GROUND STRAP	1	EA

HYDRAULIC ASSEMBLY

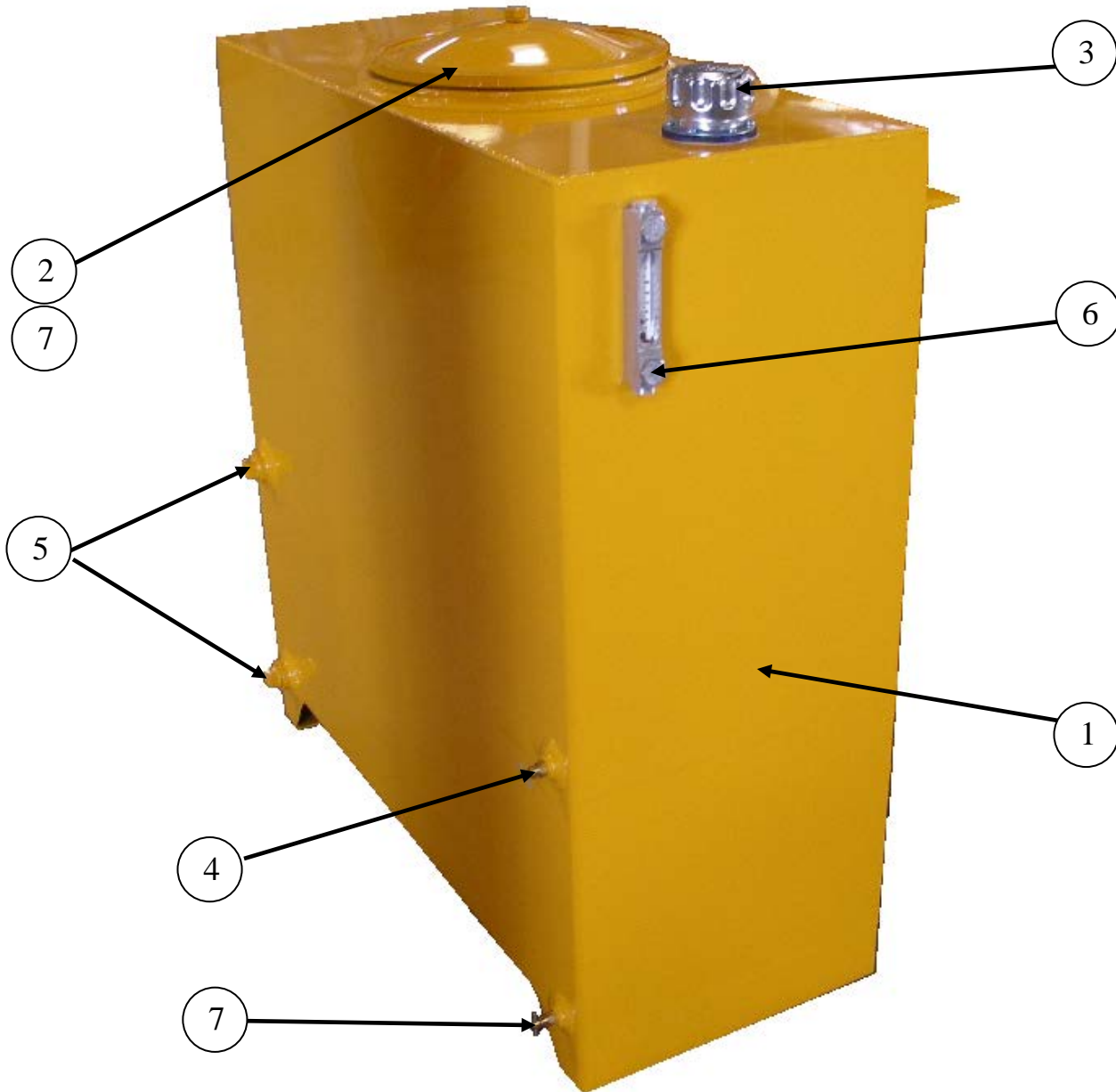

ID #	PART #	PART DESCRIPTION	QUANTITY	
	BW10432	HYD./FUEL TANK ASSY.	1	EA
1	BW10386	HYD./FUEL TANK WELDMENT	1	EA
2	BW10171	KIT, 12 END COVER	1	EA
3	74508	FILLER BREATHER W/CAP	1	EA
4	801025	DRIAN COCK, ¼ NPT	2	EA
5	10282	PLUG-PIPE / GALV 1"	2	EA
6	74509	GAUGE-SIGHT/TEMPERATURE	1	EA
7	85867	GASKET, END COVER 12" (SPARE PART)	REF	EA

FLOW CONTROL VALVE

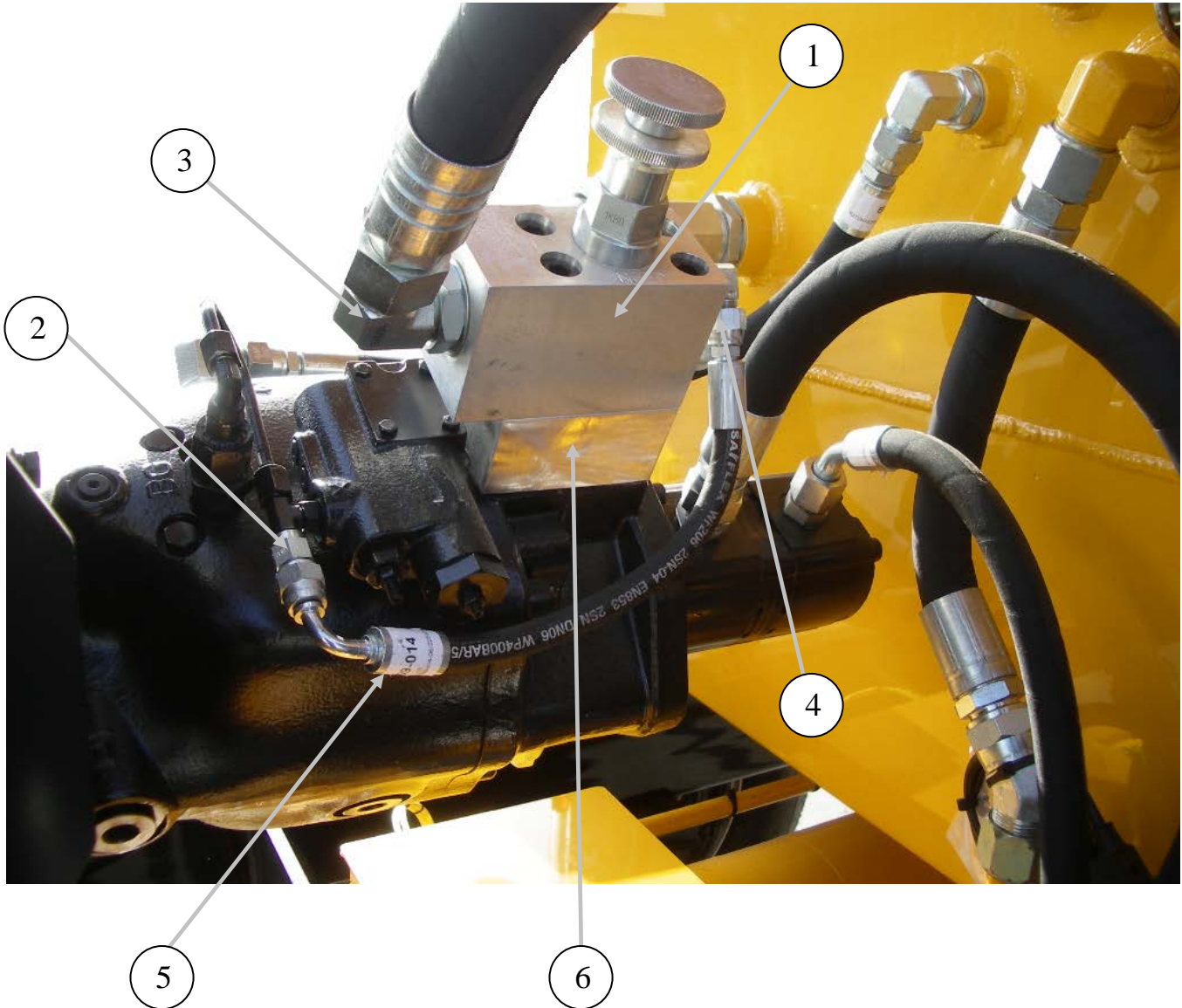

ID #	PART #	PART DESCRIPTION	QUANTITY	
1	85125	FLOW CONTROL, HV10V0100 PUMPPUMP (HI SPEED)	1	EA
2	86900-002	ADAPTER, STRAIGHT –MB-MJ-4-6	1	EA
3	86728-023	ELBOW, MB-MJ90-16-16	1	EA
4		ELBOW, MB-MJ90-4-6	1	EA
5	85659-014	HOSE, 4M2T-6FJX-6FJX90S-12.50"	1	EA
6	BW10477	SPACER 85125 FLOW VALVE SPACER	1	EA

HYDRAULIC AND FUEL TANK ASSEMBLY CONTINUED

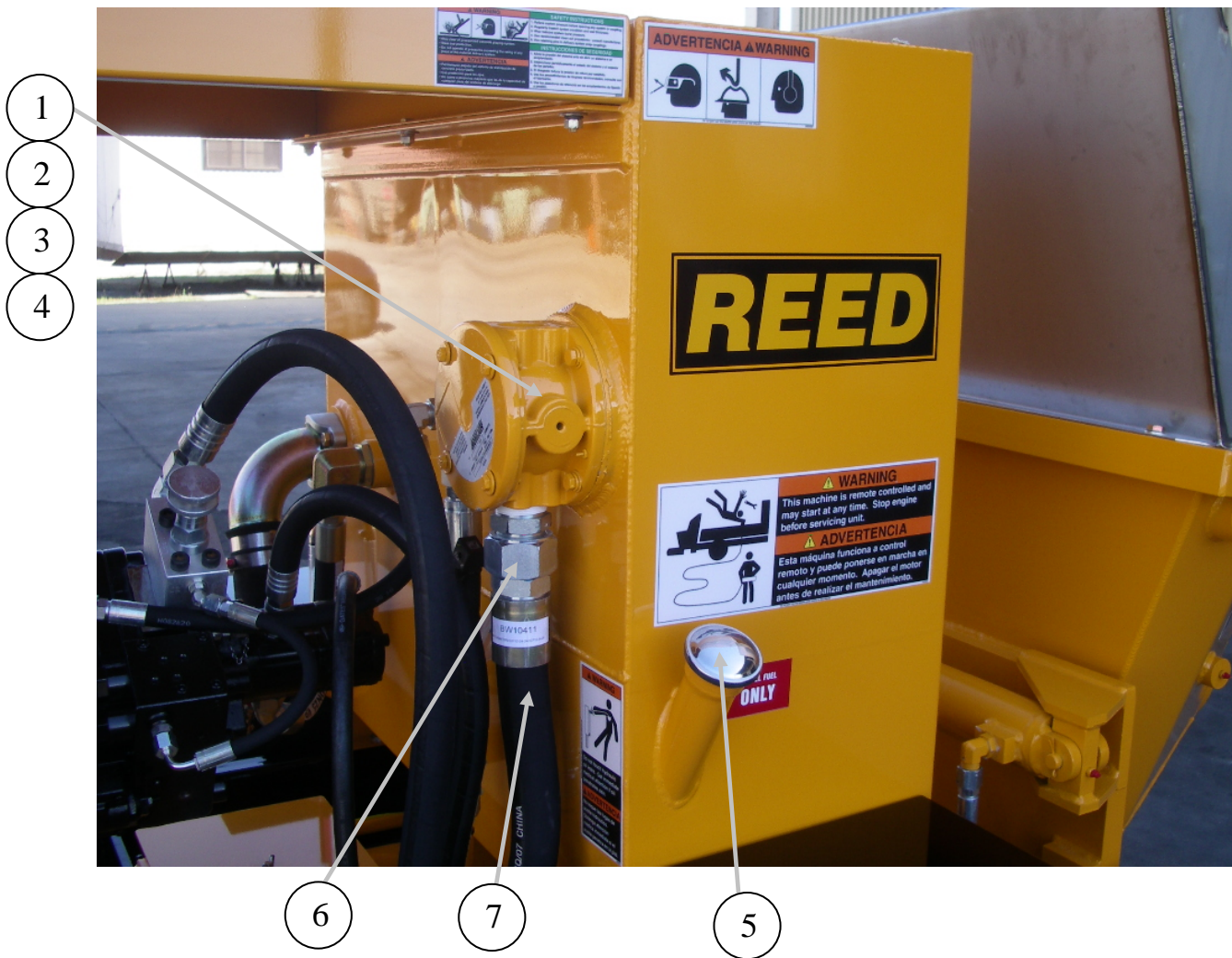

ID #	PART #	PART DESCRIPTION	QUANTITY	
1	BW10027	FILTER, RETURN	1	EA
2	BW10241	SEAL KIT FOR BW10027 (RETURN FILTER)	1	EA
3	BW10242	GASKET FOR BW10027 (RETURN FILTER)	1	EA
4	BW10106-1	ELEMENT 25 MIKRON, FOR BW10027	1	EA
5	BW10256	CAP, FILLER	1	EA
6		FITTING, MP-MJ-24-24	1	EA
7	BW10162	HOSE, 24C1TH-24FJX-24FJX-68.00	1	EA

HYDRAULIC LINES, HOSES, AND FITTINGS

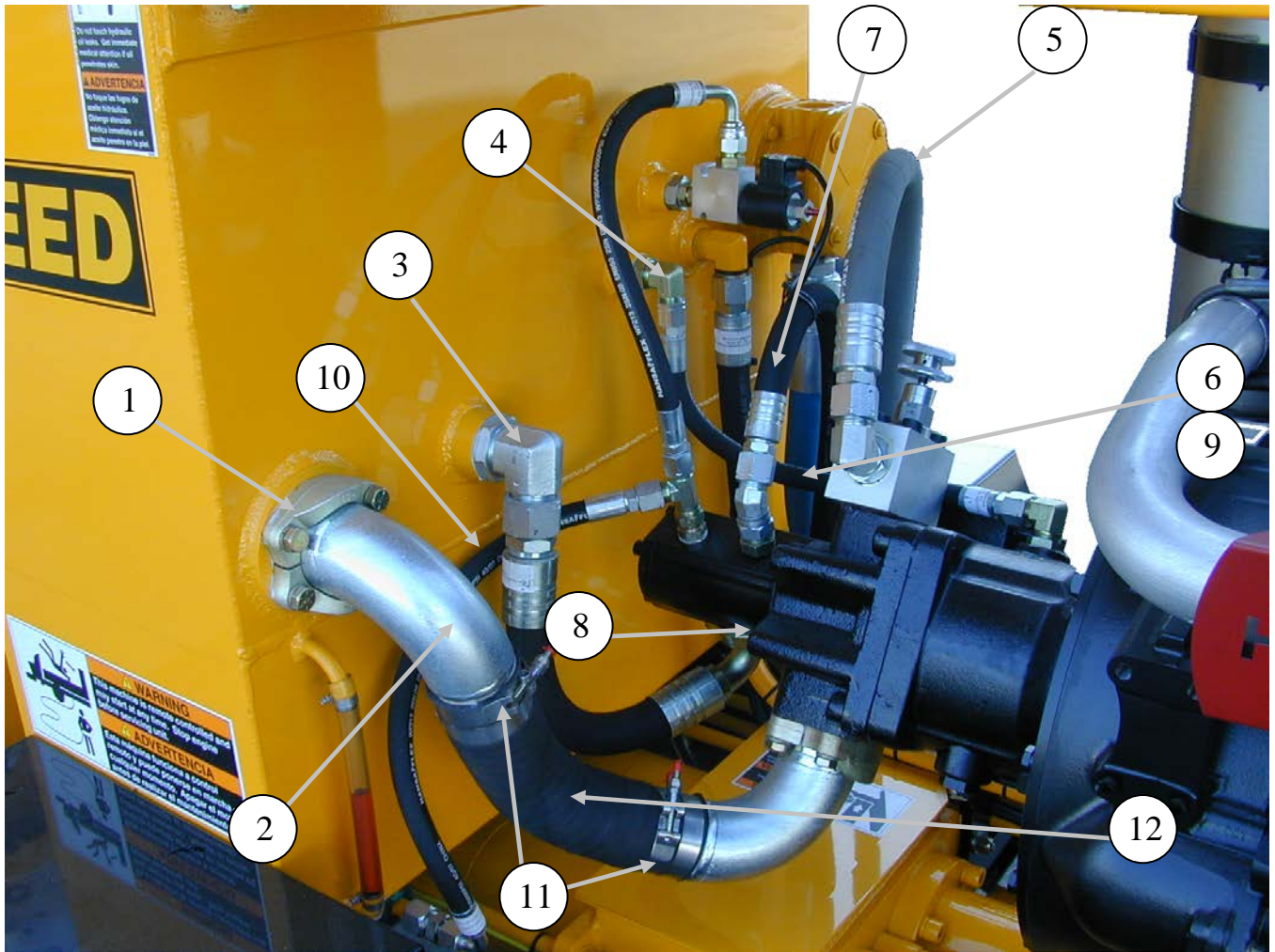

ID #	PART #	PART DESCRIPTION	QUANTITY	
1	86264-007	SPIT FLANGE-CODE 61 -40 SAE	2	EA
2	86911-009	STEM, 2 1/2 " 90 DEG. 40C4-40FL90	2	EA
3	86728-019	ELBOW MB-MJ90-12-12	2	EA
4		FITTING, MJ-MP90-16-16	1	EA
5	BW10412	HOSE, R12-FJS-FJS90-16-16-41"	1	EA
6	85667-004	HOSE, 12G5K-12FJX-12FJX90-32.00	1	EA
7	85657-002	HOSE, 8M2T-10FJX-10FJX90S-19.50	1	EA
8		FITTING, MB-MJ-10-12 (STRAIGHT)	1	EA
9		ADAPTER, MB-MJ-12-16	1	EA
10	85664-008	HOSE, 16G4H-16FJX-16FJX45-20"	1	EA
11	79803	CLAMP - T- BOLT -3.00 DIA	4	EA
12	85660-001	HOSE, 40G4H-NO ENDS-	12.00	EA

HYDRAULIC LINES, HOSES, AND FITTINGS CONT

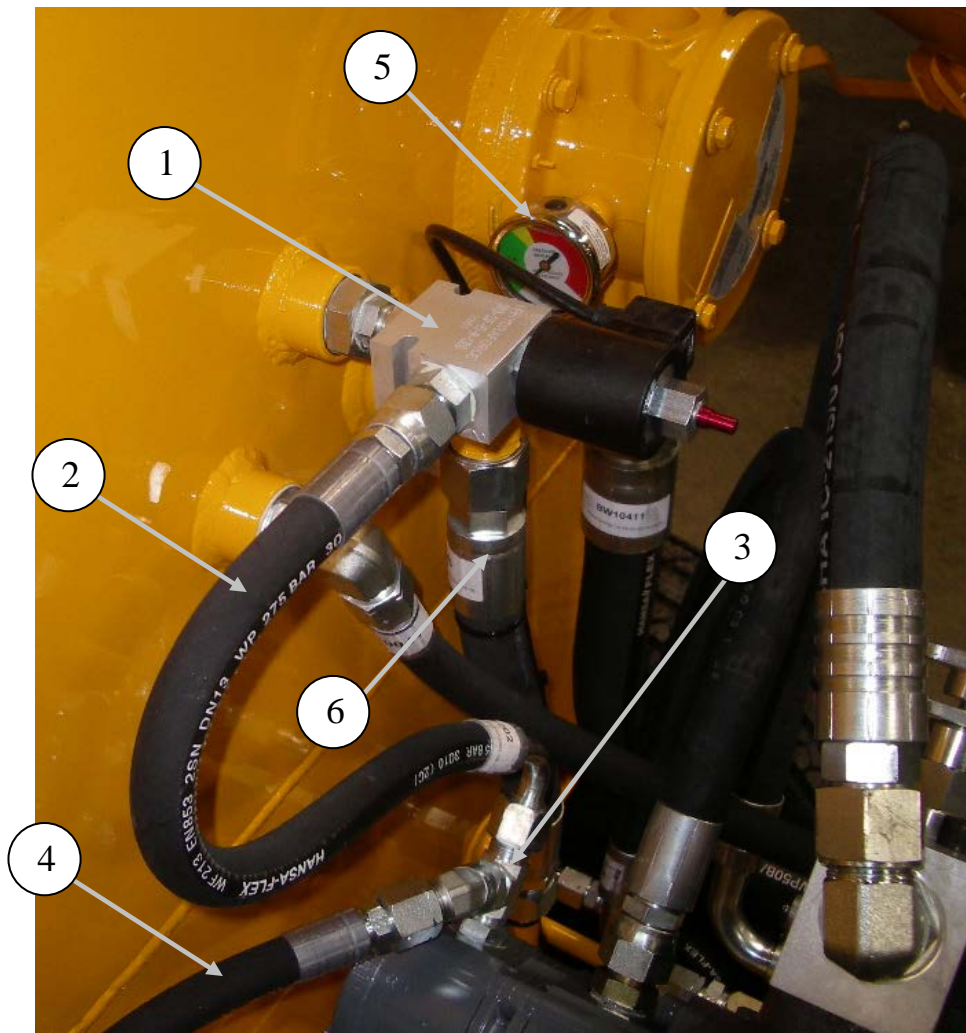

ID #	PART #	PART DESCRIPTION	QUANTITY	
1	87154	SOLENOID VALVE, 2P-2W, NO, 12V DIN	1	EA
2	85657-002	HOSE, 8M2T-10FJX-10FJX90S-19.50	1	EA
3		MJ-MB-MJT10	1	EA
4	85657-024	HOSE, 8M2T-10FJX-10FJX90S-24.50	1	EA
5	BW10249	GAUGE-RETURN FILTER BW10027	1	EA
6	BW10046	HOSE, R1T-FJS-MJ-16-16-16-14.5"	1	EA

HYDRAULIC LINES, HOSES, AND FITTINGS CONTINUED

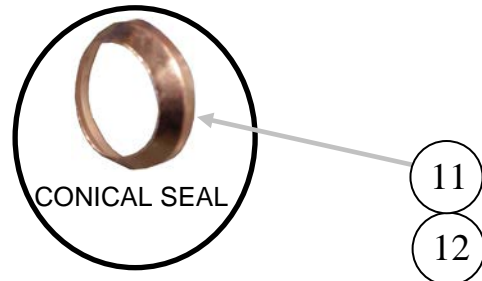
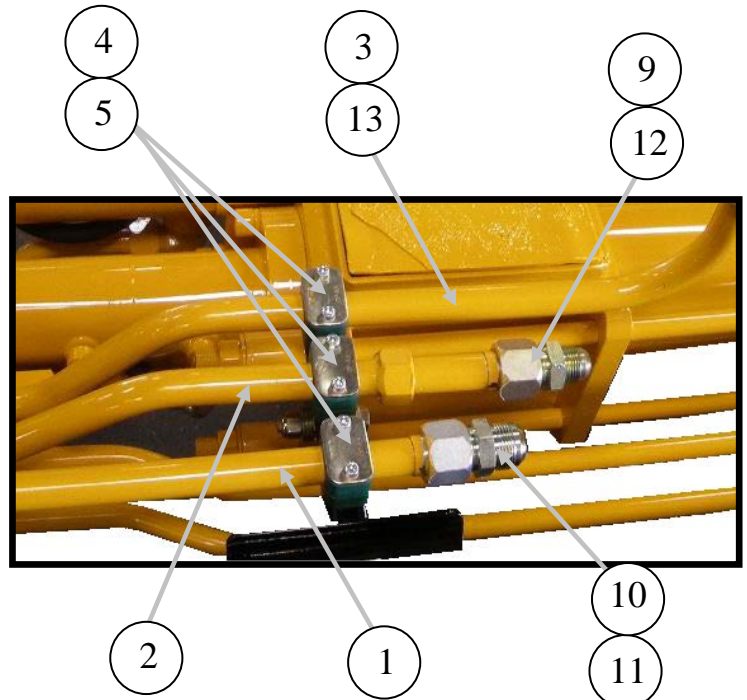
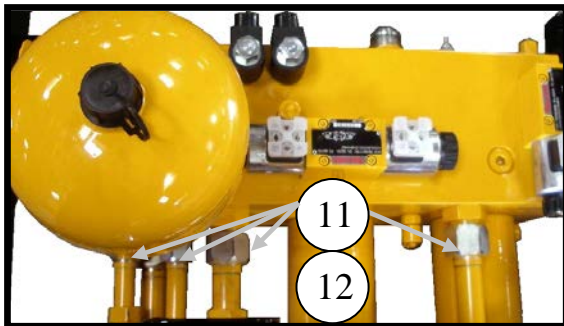

ID #	PART #	PART DESCRIPTION	QUANTITY	
1	BW10151	TUBE HYD, ACC.PUMP, PRESSURE-PAINTED	1	EA
2	BW10403	TUBE HYD, MAIN PUMP PRESSURE PAINTED	1	EA
3	BW10153	TUBE HYD, RETURN LINE-PAINTED	1	EA
4	801902-007	CLAMP, 25MM TUBE CLAMP SET	3	EA
5	801902-001	NUT, TEE TUBE CLAMP	6	EA
6	800897	CLAMP, 3/4" TUBE, SINGLE	2	EA
7	BW10154	TUBE HYD, SWING CYLINDER-PAINTED	2	EA
8		UNION MALE, MJ-MJ-12-10	2	EA
9	87415-001	UNION MALE JIC, MJ-MJ-16-12	1	EA
10	87415-002	UNION MALE JIC, MJ-MJ-12-12	1	EA
11	BW10229	CONICAL SEAL, SIZE 12	5	EA
12	BW10230	CONICAL SEAL, SIZE 16	6	EA
13	BW10049	HOSE R2T-FJS-FJS-10-10-08-20"	2	EA

HYDRAULIC LINES, HOSES, AND FITTINGS CONTINUED

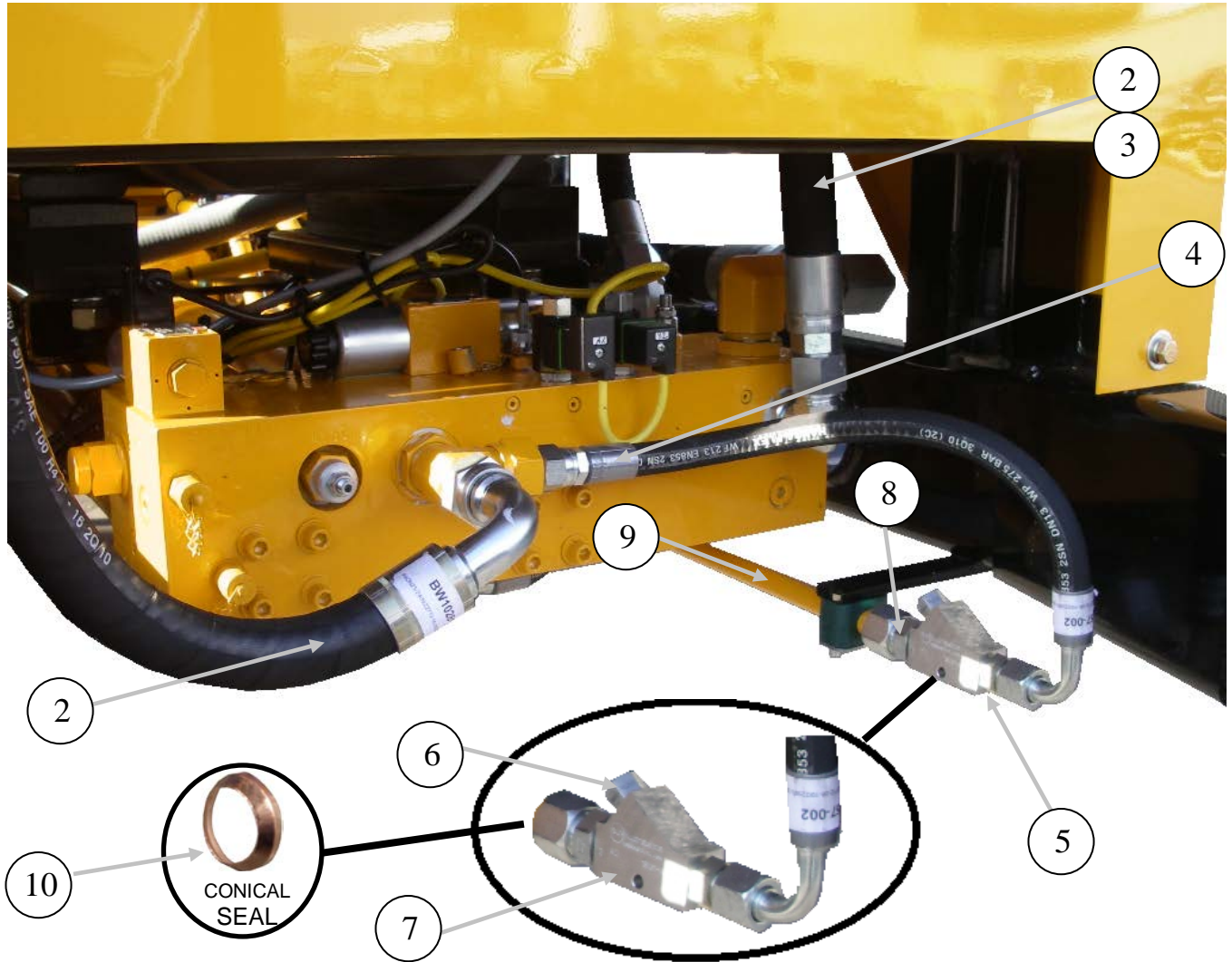

ID #	PART #	PART DESCRIPTION	QUANTITY	
1	BW10280	HOSE, 16GMV=-20FJX-16FJX90S-24"	1	EA
2		HOSE, 16GMV=-16FJX-16FJX	1	EA
3	86728-026	ELBOW, MB-MJ90-20-16	1	EA
4	85657-002	HOSE, 8M2T-10FJX-10FJX90S-19.50	1	EA
5		MB-MJ-6-10	1	EA
6	BW10471	CHECK VALVE	1	EA
7	BW10472	MANIFOLD FOR BW10471 (MUST BE MODIFIED)	1	EA
8		MB-MJ-6-12	1	EA
9	BW10409	TUBE HYD. MIXER VALVE RETURN	1	EA
10	BW10229	CONICAL SEAL, SIZE 12	2	EA

BLANK PAGE



CONTROL MANIFOLD

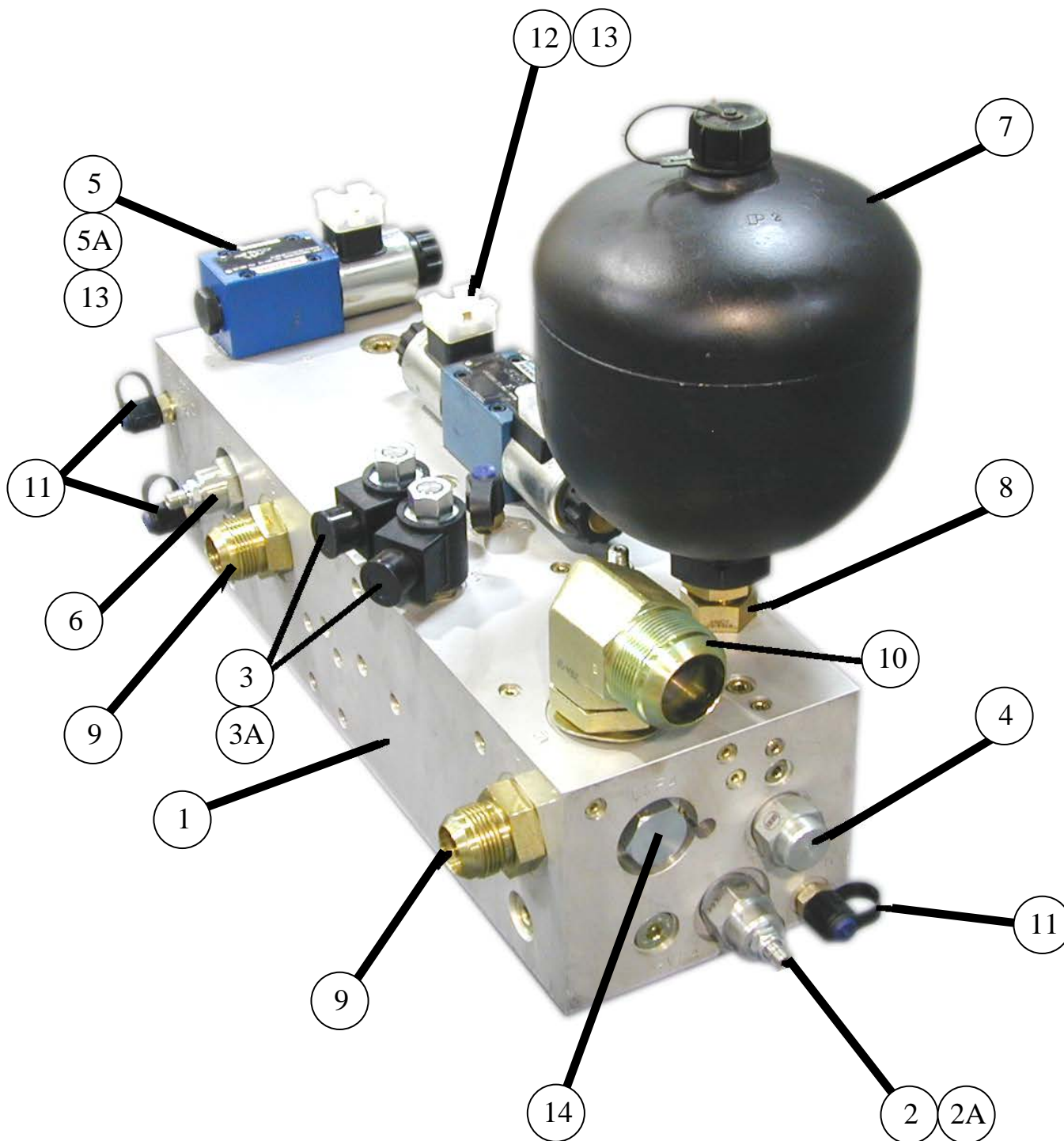

**45 TO 50
FT.LBS**



A40HP PARTS

13822 Oaks Avenue
Chino, CA 91710
reedpumps.com
909-287-2100

CONTROL MANIFOLD CONTINUED

ID #	PART #	PART DESCRIPTION	QUANTITY	
	BW10395	MANIFOLD, CYLINDER CIRCUIT ASSEMBLY, A40	1	EA
1	BW10375	MANIFOLD MACHINED, A40 SERIES	1	EA
2	85703	RELIEF VALVE CARTRIDGE, FOR 85249	1	EA
2A	85703SK	RELEIF VALVE CARTRIDGE SEAL KIT	1	EA
3	BW10185	VALVE POPET, 2 WAY N/O FORBW10186	2	EA
3A	87247	COIL, 12VDC, FOR 87246	2	EA
4	BW10182	DIRECTIONAL CARTRIDGE VALVE 2 POSIT	1	EA
4A	BW10182-SK	DIRECTIONAL CARTRIDGE VALVE SEAL KIT	1	EA
5	BW10183	VALVE PILOT, 2 POSITION	1	EA
5A	BW10183-SK	DIRECTIONAL CARTRIDGE VALVE SEAL KIT	1	EA
6	BW10326	RELIEF VALVE CARTRIDGE, FOR BW1004	1	EA
7	BW10184	ACCUMULATOR, 2 LITER	1	EA
8	BW10328	ADAPTER, MB-MB-12-12	1	EA
9	86900-028	ADAPTER, MB-MJ-16-16	2	EA
10	86728-028	ELBOW, MB-MJ90-20-24	1	EA
11	78593	MINICHECK ADAPTER, SAE 4	2	EA
12	85691	VALVE PILOT, FOR 85689	1	EA
13	BW10329	10-24X2" SHCS (TORQE 6.5 FT. LBS.)	8	EA
14	BW10327	CHECK VALVE CARTRIDGE FOR BW10004	1	EA

INSTALLATION TORQUE-CHART	
ITEM/CODE	TORQUE SETTING
RPGC	45 TO 50 FT. LBS.
CXFA	45 TO 50 FT. LBS.
RVEA	45 TO 50 FT. LBS.
QCDB	35 FT. LBS.
DCDD	50 FT. LBS.
DCEC	160 FT. LBS.
ITEM 4	20 FT. LBS.
ITEM 4A	5 FT. LBS.
ITEM 5&7	6.5 FT. LBS.

CONTROL MANIFOLD FRONT SIDE

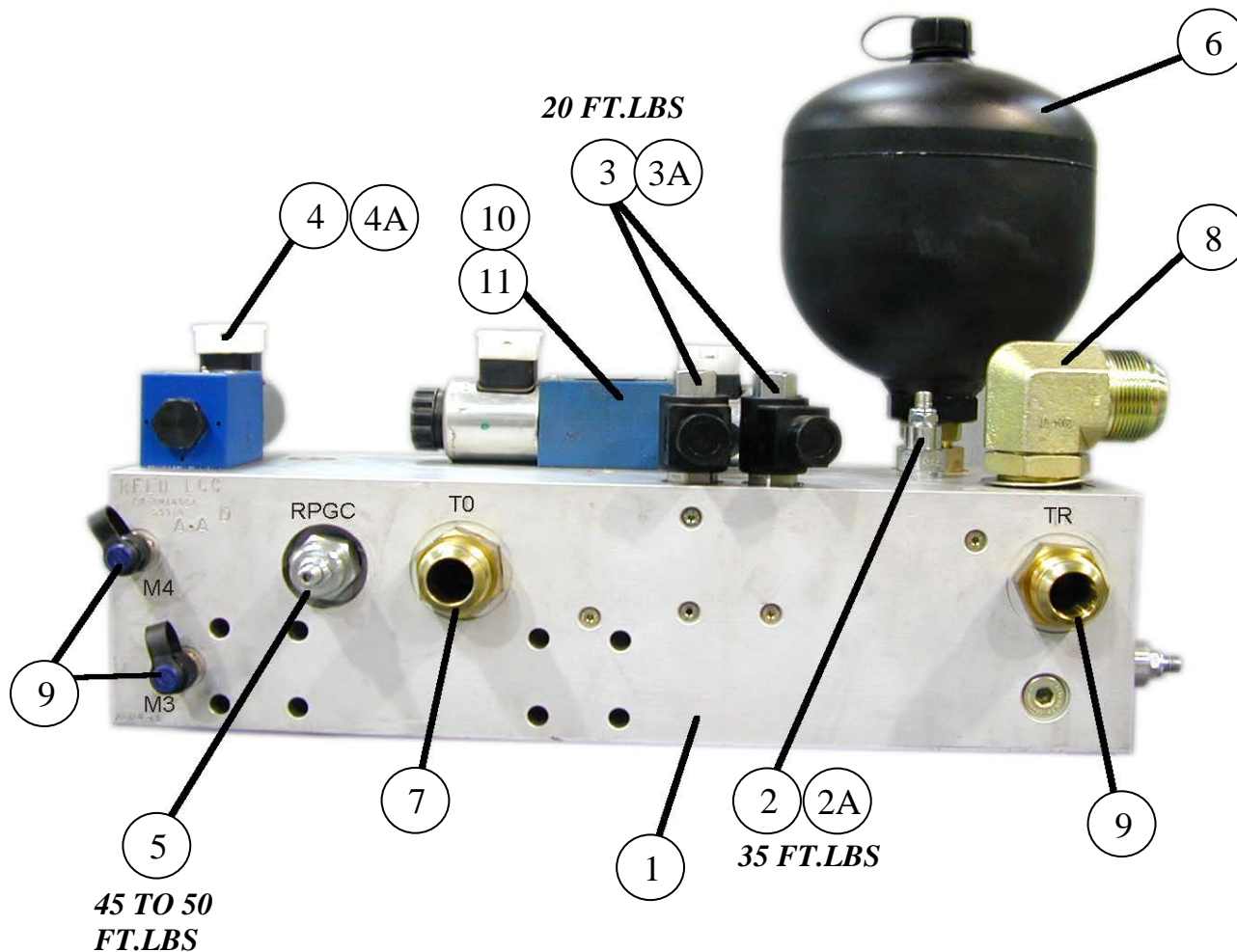

ID #	PART #	PART DESCRIPTION	QUANTITY	
1	BW10375	MANIFOLD MACHINED, A40 SERIES	1	REF
2	85704	UNLOADER VALVE CARTRIDGE, FOR 85249	1	REF
2A	85704-SK	UNLOADER VALVE CARTRIDGE SEAL KIT	1	EA
3	BW10185	VALVE POPET, 2 WAY N/O FORBW10186	2	REF
3A	87247	COIL, 12VDC, FOR 87246	2	REF
4	BW10183	VALVE PILOT, 2 POSITION	1	REF
4A	BW10183-SK	DIRECTIONAL CARTRIDGE VALVE SEAL KIT	1	REF
5	BW10326	RELIEF VALVE CARTRIDGE, FOR BW1004	1	REF
6	BW10184	ACCUMULATOR, 2 LITER	1	REF
7	86900-028	ADAPTER, MB-MJ-12-12	2	REF
8	86728-028	ELBOW, MB-MJ90-20-24	1	REF
9	78593	MINICHECK ADAPTER, SAE 4	2	REF
10	85691	VALVE PILOT, FOR 85689	1	REF
11	BW10329	10-24X2" SHCS (TORQUE 6.5 FT. LBS.)	8	REF

CONTROL MANIFOLD CYLINDER SIDE

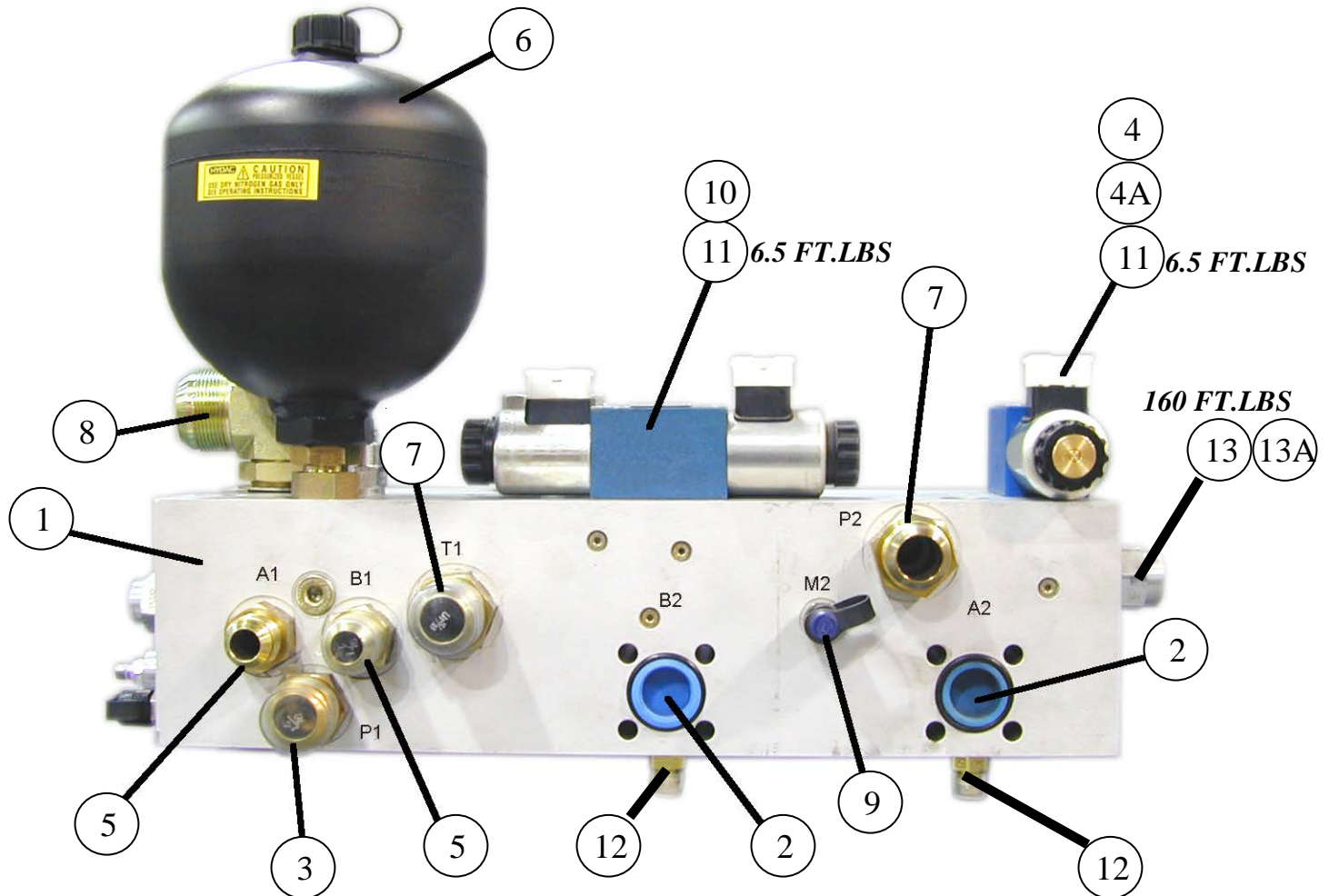

ID #	PART #	PART DESCRIPTION	QUANTITY	
1	BW10375	MANIFOLD MACHINED, A40 SERIES	1	REF
2	BW10177	O-RING, #219	2	EA
3	86900-024	ADAPTER, MB-MJ-12-16	1	EA
4	BW10183	VALVE PILOT, 2 POSITION	1	REF
4A	BW10183-SK	DIRECTIONAL CARTRIDGE VALVE SEAL KIT	1	REF
5	86900-23	ADAPTER, MB-MJ-12-12	2	EA
6	BW10184	ACCUMULATOR, 2 LITER	1	REF
7	86900-028	ADAPTER, MB-MJ-16-16	2	REF
8	86728-028	ELBOW, MB-MJ90-20-24	1	REF
9	78593	MINICHECK ADAPTER, SAE 4	2	REF
10	85691	VALVE PILOT, FOR 85689	1	REF
11	BW10329	10-24X2" SHCS (TORQUE 6.5 FT. LBS.)	8	REF
12	86900-002	ADAPTER, MB-MJ-4-6	2	EA
13	BW10181	DIRECTIONAL CARTRIDGE VALVE 3 POSIT	1	EA
13A	BW10181-SK	DIRECTIONAL CARTRIDGE VALVE SEAL KIT	1	EA



A40HP PARTS

13822 Oaks Avenue
Chino, CA 91710
reedpumps.com
909-287-2100

CONTROL MANIFOLD PORTING

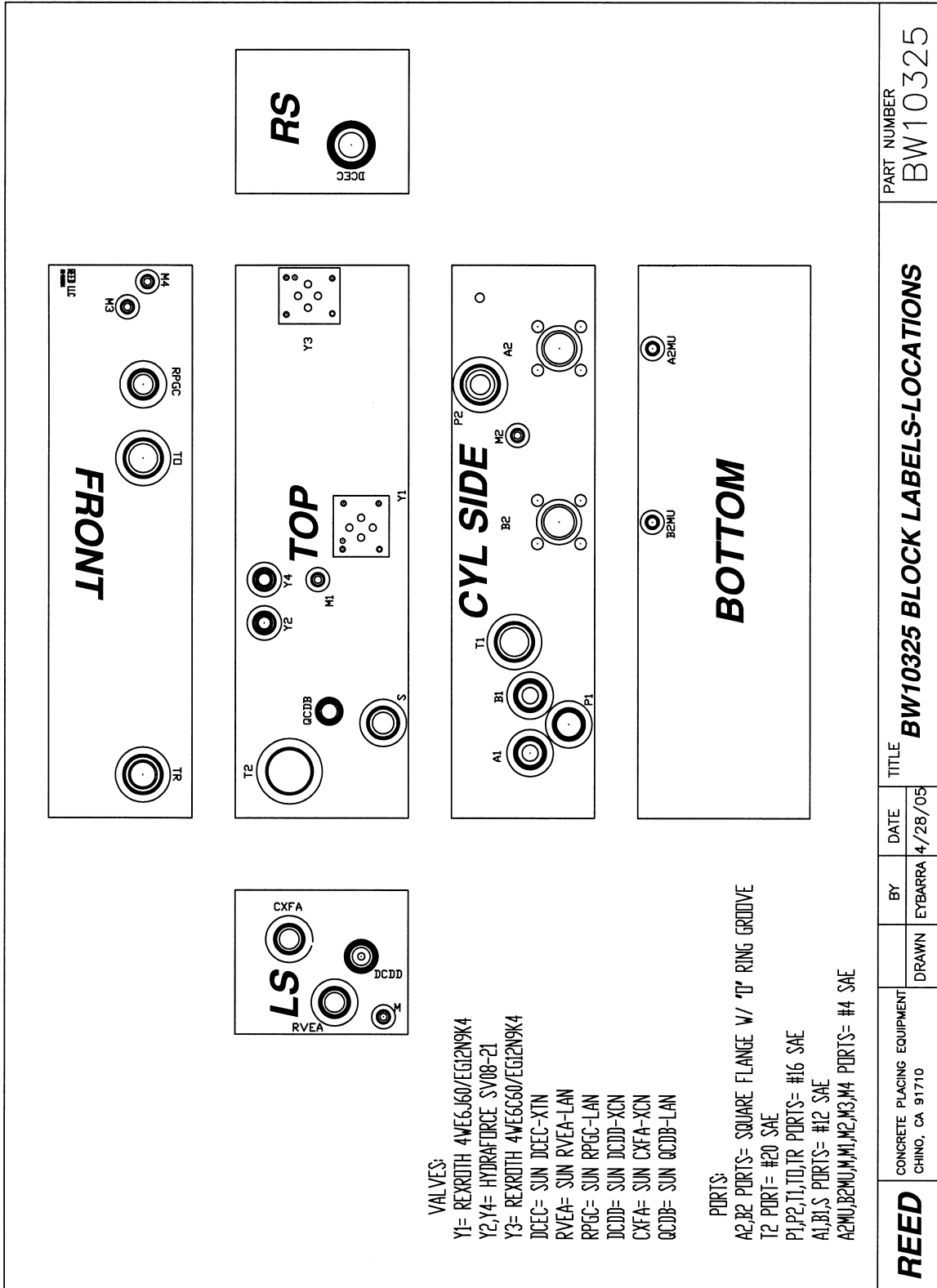

SOLENIOD VALVE ASSEMBLIES

REVERSE CIRCUIT PILOT SOLENOID
VALVE ASSEMBLY

BW10183

O-RING KIT
72313

PLUG
74597

COIL
85692

PLUG
74597

COIL
85692

PLUG
74597

COIL
85692

MAIN CYCLING PILOT SOLENOID
VALVE ASSEMBLY

85691

O-RING KIT
72313

ELECTRICAL GROUP

BATTERY

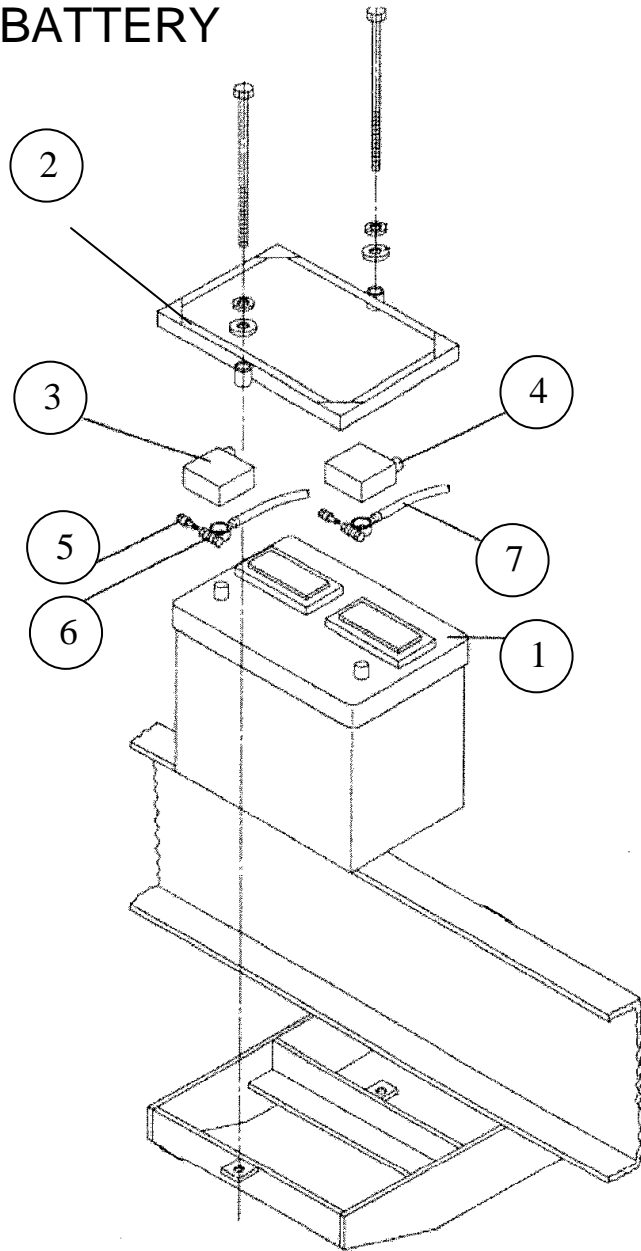

ID #	PART #	PART DESCRIPTION	QUANTITY	
	BW44020	ELECTRICAL GROUP A SER BW10039-2	1	EA
1	77075	BATTERY-12V 1000 CCA31	1	EA
2	72945	BATTERY HOLD DOWN	1	EA
3	77719	COVER, POSITIVE BATT-RED	1	EA
4	77720	COVER, NEGATIVE BATT-BLACK	1	EA
5	87223	EXTENDER, TOP TERMINAL BOLT	2	EA
6	72014	CABLE-38" BATTERY-RED	1	EA
7	75116	CABLE-26" BATTERY-BLACK	1	EA

PROXIMITY SWITCHES

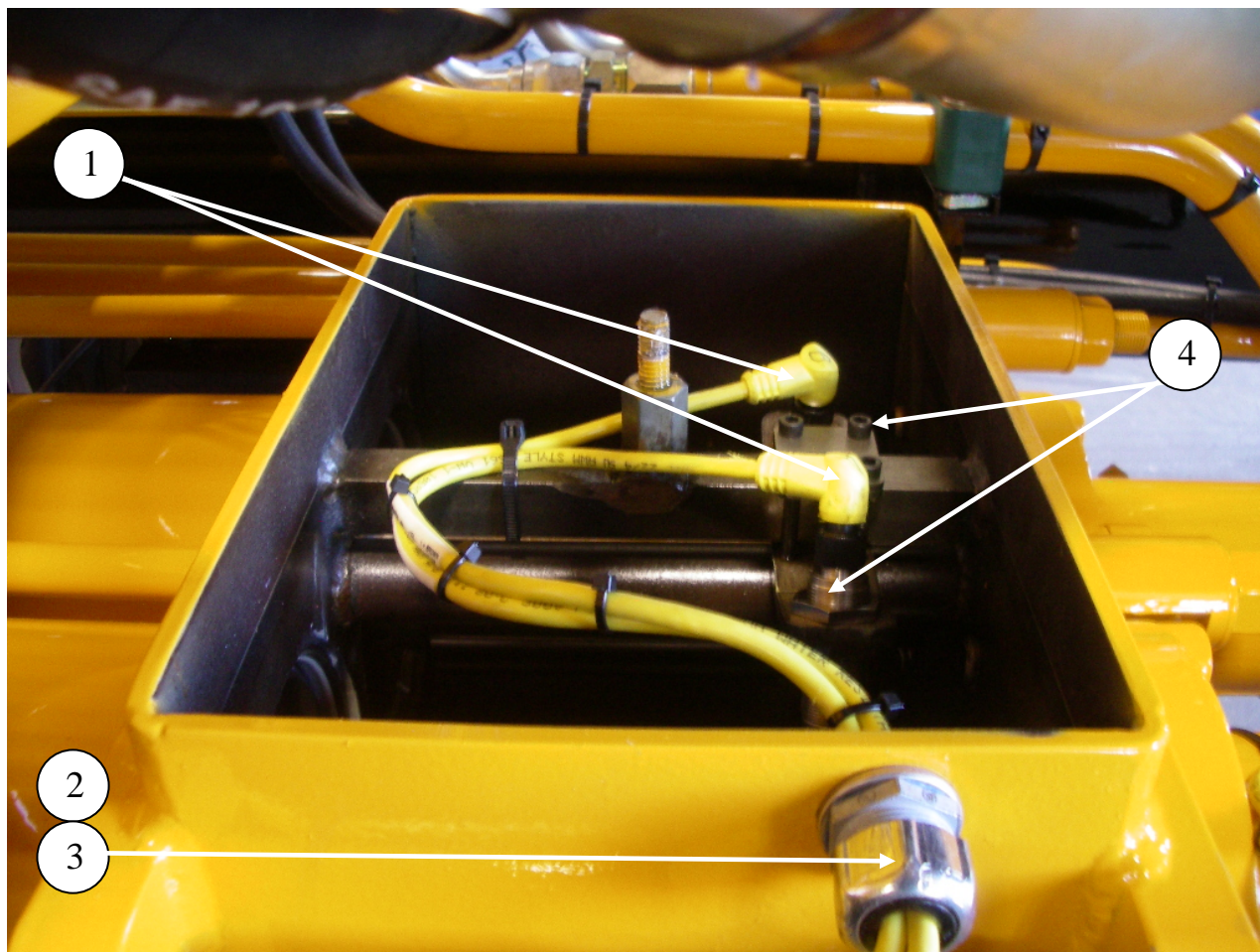

ID #	PART #	PART DESCRIPTION	QUANTITY	
1	77990	CABLE, PROXIMITY SWITCH	2	EA
2	10522	STRAIN RELIEF	1	EA
3	10528	NUT ½" BONDING TYPE LOCK	1	EA
4	77998	PROXIMITY SENSOR NPN	2	EA

STARTER RELAY

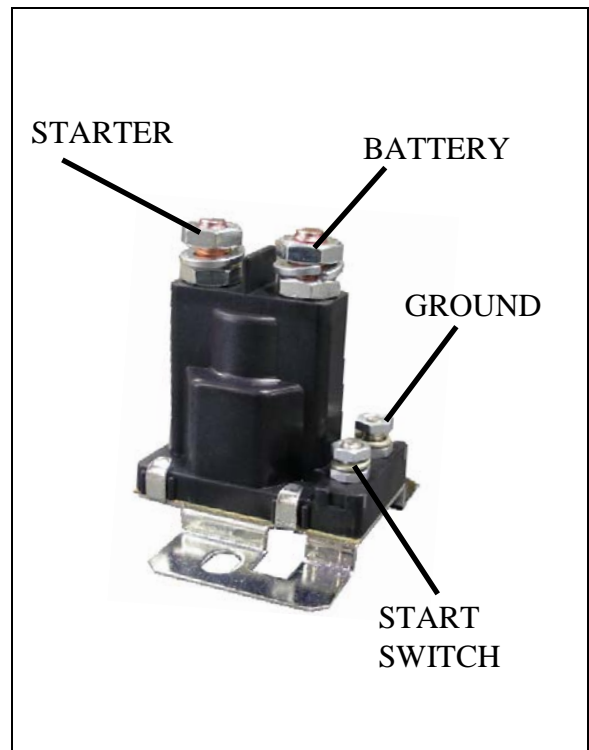
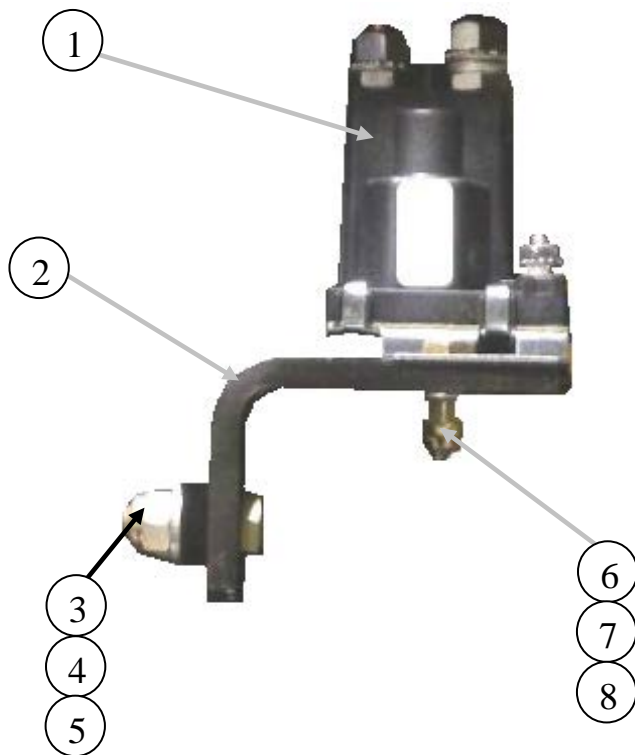

ID #	PART #	PART DESCRIPTION	QUANTITY	
1	87541	RELAY STARTER 12VDC-SELL W/87544	1	EA
2	87544	BRACKET STARTER RELAY MOUNT	1	EA
3		SHCS, 5/16-18X1"	2	EA
4		FLAT WASHER, 5/16	2	EA
5		LOCK WASHER, 5/16	2	EA
6		SHCS, 1/4-20X3/4" 2	2	EA
7		FLAT WASHER 1/4"	2	EA
8		LOCK WASHER 1/4"	2	EA

TRAILER HARNESS AND BREAKAWAY

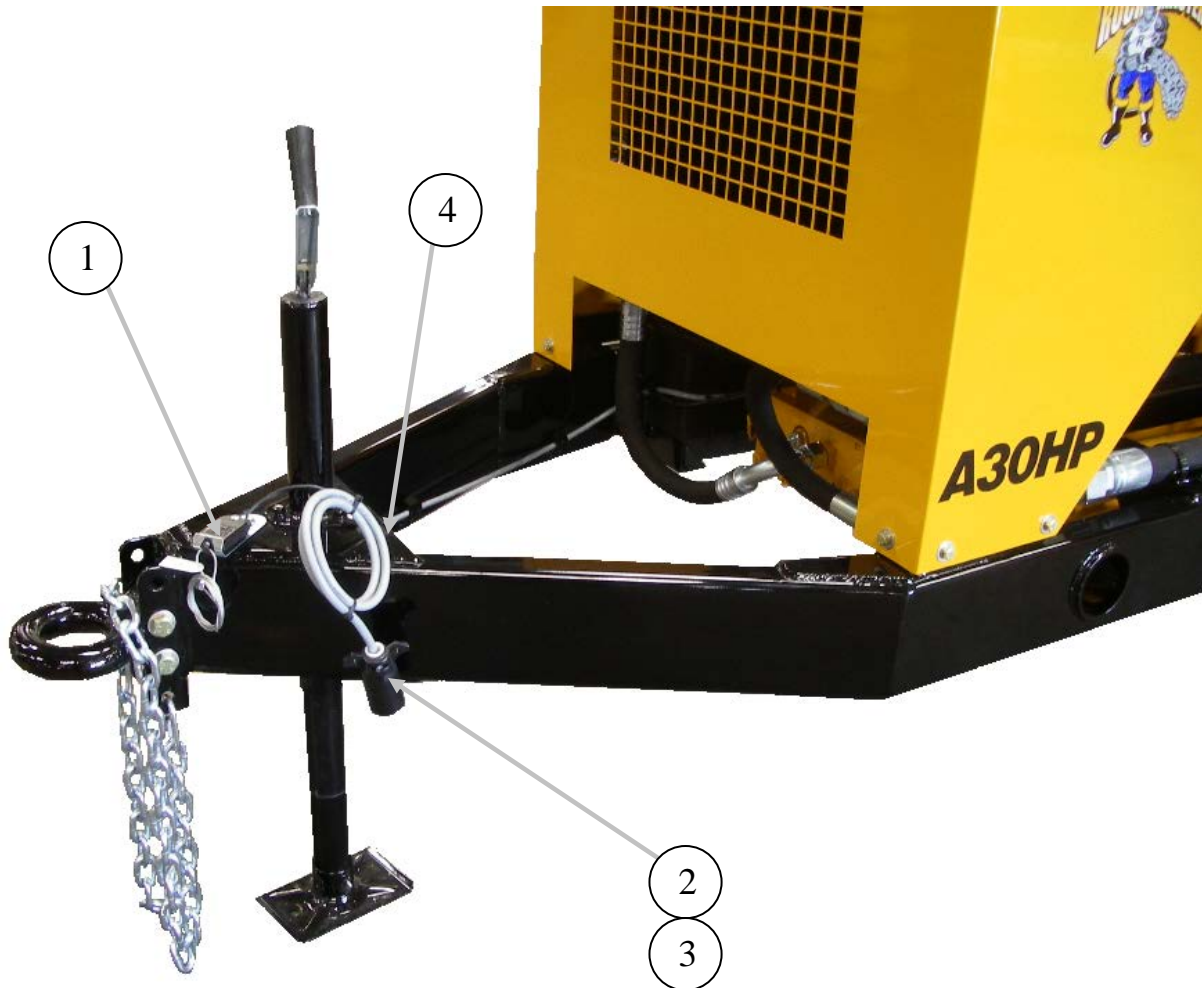

ID #	PART #	PART DESCRIPTION	QUANTITY	
1	77705	BREAK-AWAY KIT 5000 SERIES	1	EA
2	86579	TRAILER PLUG 7C FLAT PI	1	EA
3	BW10139	WIRING HARNESS , TRAILER A SERIES	1	EA
4	86759	GROMMET	1	EA

TAILLIGHTS



UNDERNEATH
FENDER

ID #	PART #	PART DESCRIPTION	QUANTITY	
1	72948	TAIL LIGHT R3000 SERIES	2	EA
2	85981	LOOM CLAMP 5/8"	2	EA
3	86759	GROMMET	2	EA

WIRING HARNESS

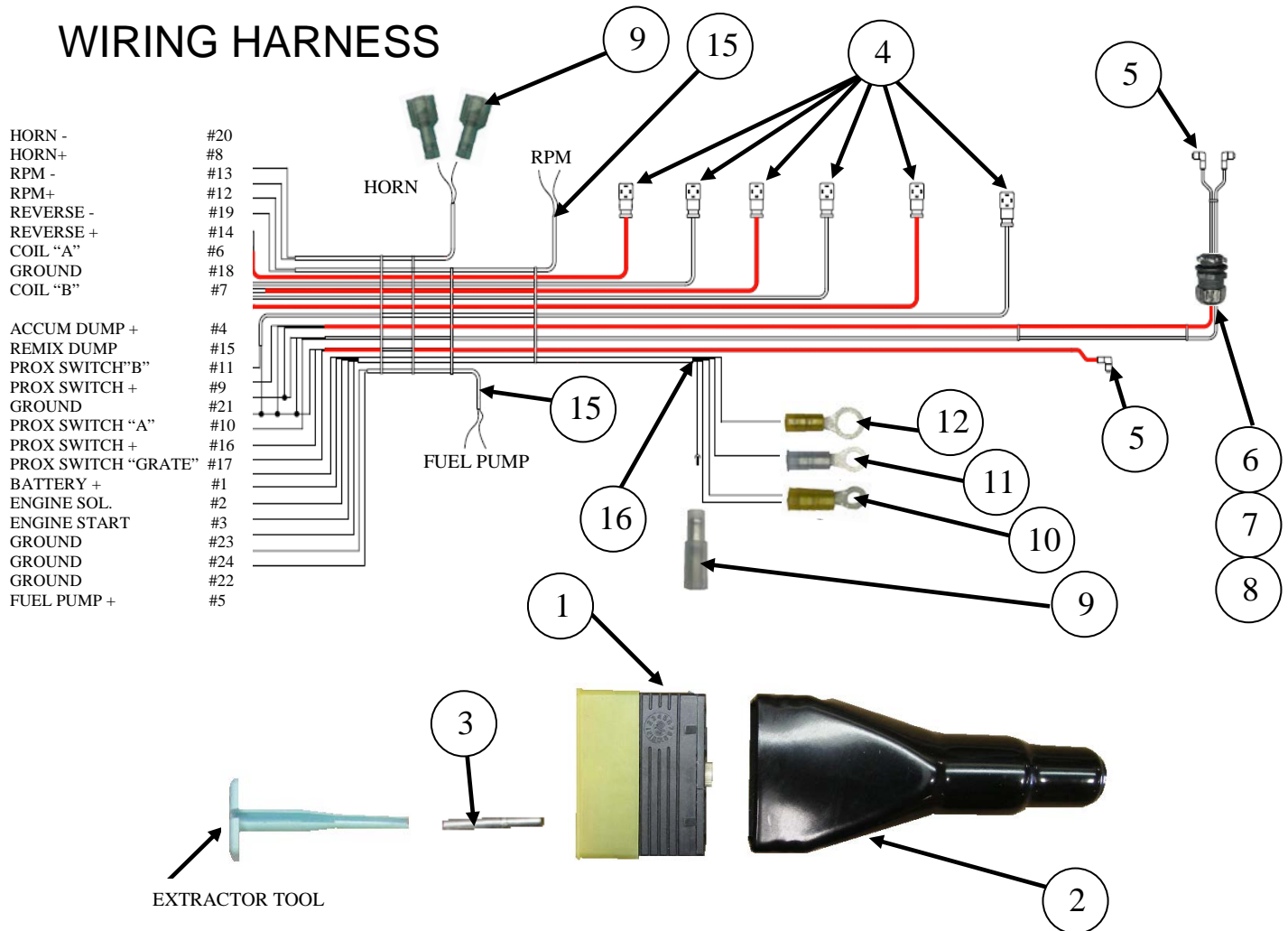

ID #	PART #	PART DESCRIPTION	QUANTITY	
	BW10414	WIRING HARNESS A SERIES, BW10039-2	1	EA
1	BW10145	PLUG CONNECTOR	1	EA
2	BW10146	BOOT, FOR BW10145 PLUG	1	EA
3	BW10147	PIN, FOR BW10145 PLUG	24	EA
4	88243	CABLE W/2 DIN PLUGS, 5M LONG	3	EA
5	77990	CABLE, PROXIMITY SWITCH, 5M	3	EA
6	10528	NUT- 1/2" BONDING TYPE LOCK NUT	1	EA
7	10522	STRAIN RELIEF	1	EA
8	30240	GASKET- LIQUID TITE- ELECT	1	EA
9		BULLET RECEPACAL, 0.180", 16-14 Ga.	1	EA
10		10 Stud, 12-10 Ga. (YELLOW NYLON)	1	EA
11		10 Stud, 12-10 Ga. (BLUE NYLON)	1	EA
12		3/8" Stud, 12-10 Ga. (YELLOW NYLON)	1	EA
13		0.250", 16-14 Ga. (BLUE NYLON)	1	EA
14		1" DIA WIRE LOOM PLASTIC	3	FT
15	85618	CABLE, 16 AWG-2C, PVC-GRY	REF	
16	86531	CABLE, 14 AWG-5C, PVC-GRY	REF	

CONTROLS A-SERIES CONTROL BOX





A40HP PARTS

13822 Oaks Avenue
Chino, CA 91710
reedpumps.com
909-287-2100

A-SERIES CONTROL BOX CONTINUED

ID #	PART #	PART DESCRIPTION	QUANTITY	
	BW10343-1	CONTROL BOX, A SERIES	1	EA
1	BW10203	A-1008CH 10X8X4 STEEL ENCL	1	EA
2	BW10354	KEY SWITCH, IGNITION, W/2KEYS	1	EA
3	BW10205	SW, TOGGLE (ON-OFF) RPM	1	EA
4	BW10206	SW, TOGGLE (ON-OFF) STROKE CHANGE & HORN	2	EA
5	BW10207	SW, TOGGLE (ON -OFF) PUMP ON/OFF & FWD/REV	2	EA
6	BW10223	SW, TOGGLE (ON-ON) LOCAL & REMOTE	1	EA
7	BW10361	SW, SEALING BOOT	9	EA
8	BW10208	MUSROOM HEAD MAINTIANED BUTT.	1	EA
9	BW10358	E-STOP LIGHT	1	EA
10	BW10357	CONTACT BLOCK (NORMALLY CLOSED)	1	EA
11	BW10359	LGT, WL-41047MINI RED 15	1	EA
12	BW10212	MINI HOURMETER	1	EA
13	BW10369	LED, PILOT LIGHT (GRN)	4	EA
14	BW10371	LED, PILOT LIGHT (AMBER)	1	EA
15	BW10355	SW, PB GRN FLUSH (ENG START)	1	EA
16		DECAL, 401289A DWG	1	EA
17	88017	SW, CONTACT BLOCK (NORMALLY OPEN)	1	EA
18	72862	GAUGE FOR PROX. SENSOR SETTING	1	EA

CONTACT BLOCKS

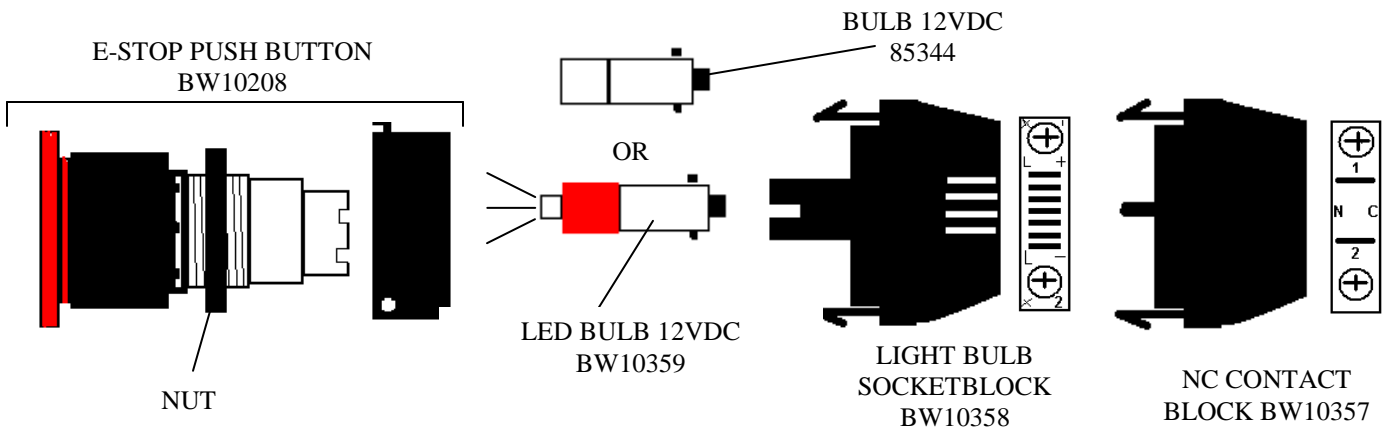
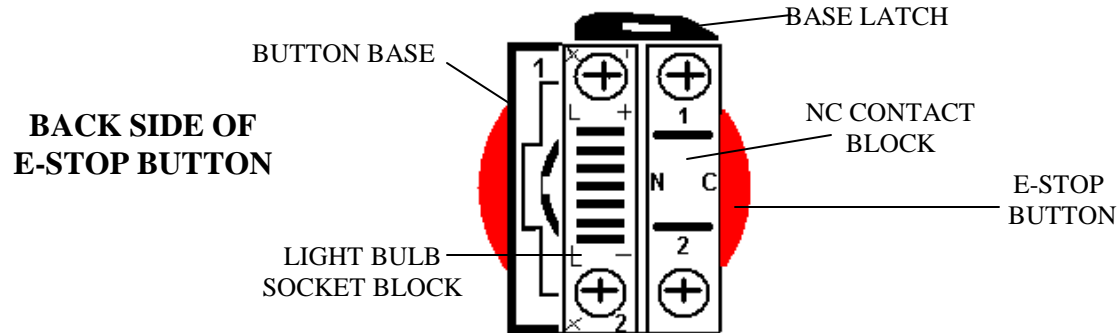

ENGINE START BUTTON ASSEMBLY

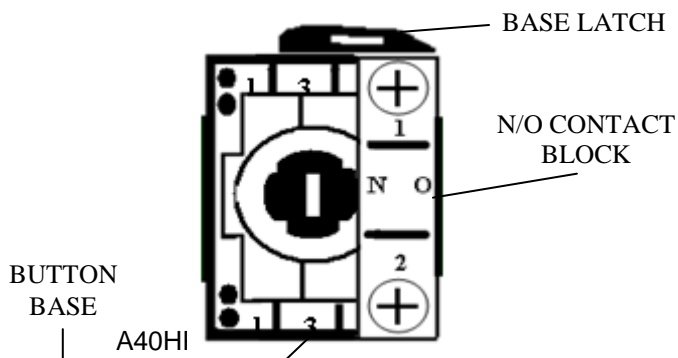
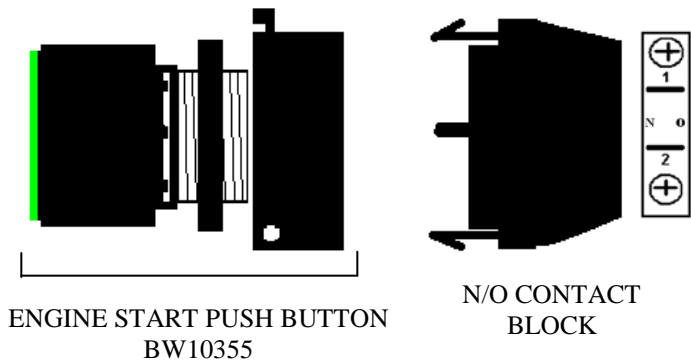

SYSTEM ON BUTTON ASSEMBLY

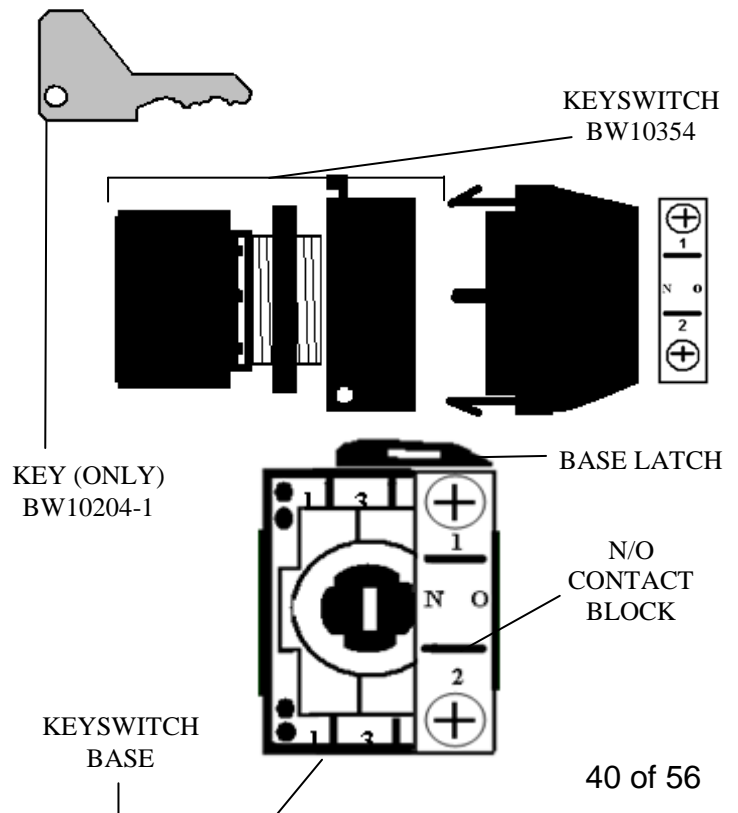

FUSES AND RELAYS

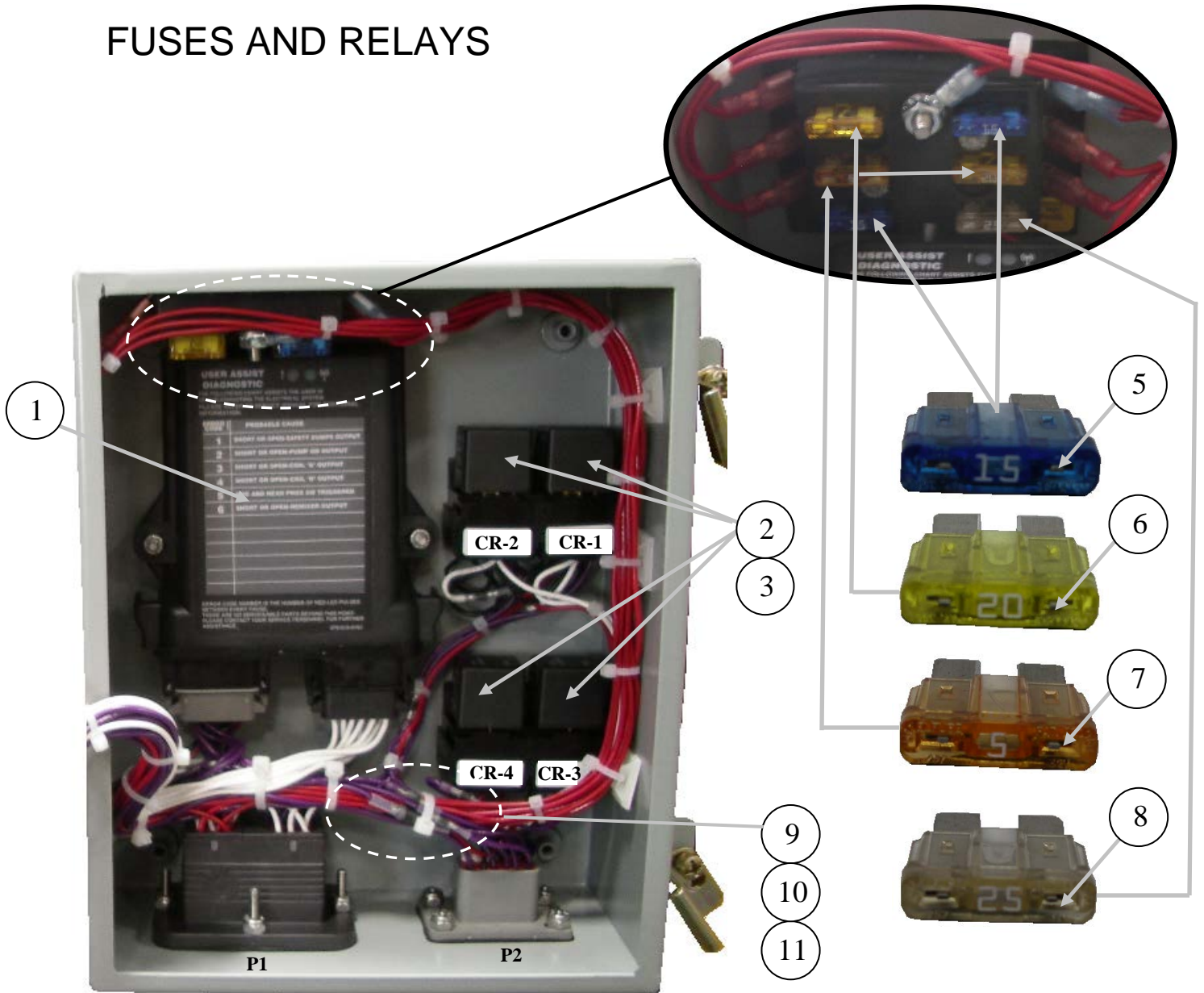

ID #	PART #	PART DESCRIPTION	QUANTITY	
1	BW10255-1	LOGIC CONTROLLER, A SERIES, REF F W/SAFTY GR	1	EA
2	BW10222	RELAY, DIODE SUPPRESSED	4	EA
3	BW10224	SOCKET, RELAY SCKT	4	EA
4	BW10227	FUSE BLOCK, GHG 6F	1	EA
5	90391	FUSE, 257015 LTL 15 A ATO	2	EA
6	800448	FUSE, 257020 LTL 20A ATO	2	EA
7	90392	FUSE, 257005 LTL 5A ATO	1	EA
8	800447	FUSE, 257025 LTL 25A ATO	1	EA
9	BW10225	DIODE, 1N4001	7	EA
10	BW10226	DIODE, TSF12	2	EA
11	BW10228	DIODE, 1N5404	2	EA



A40HP PARTS

13822 Oaks Avenue
Chino, CA 91710
reedpumps.com
909-287-2100

CONNECTORS

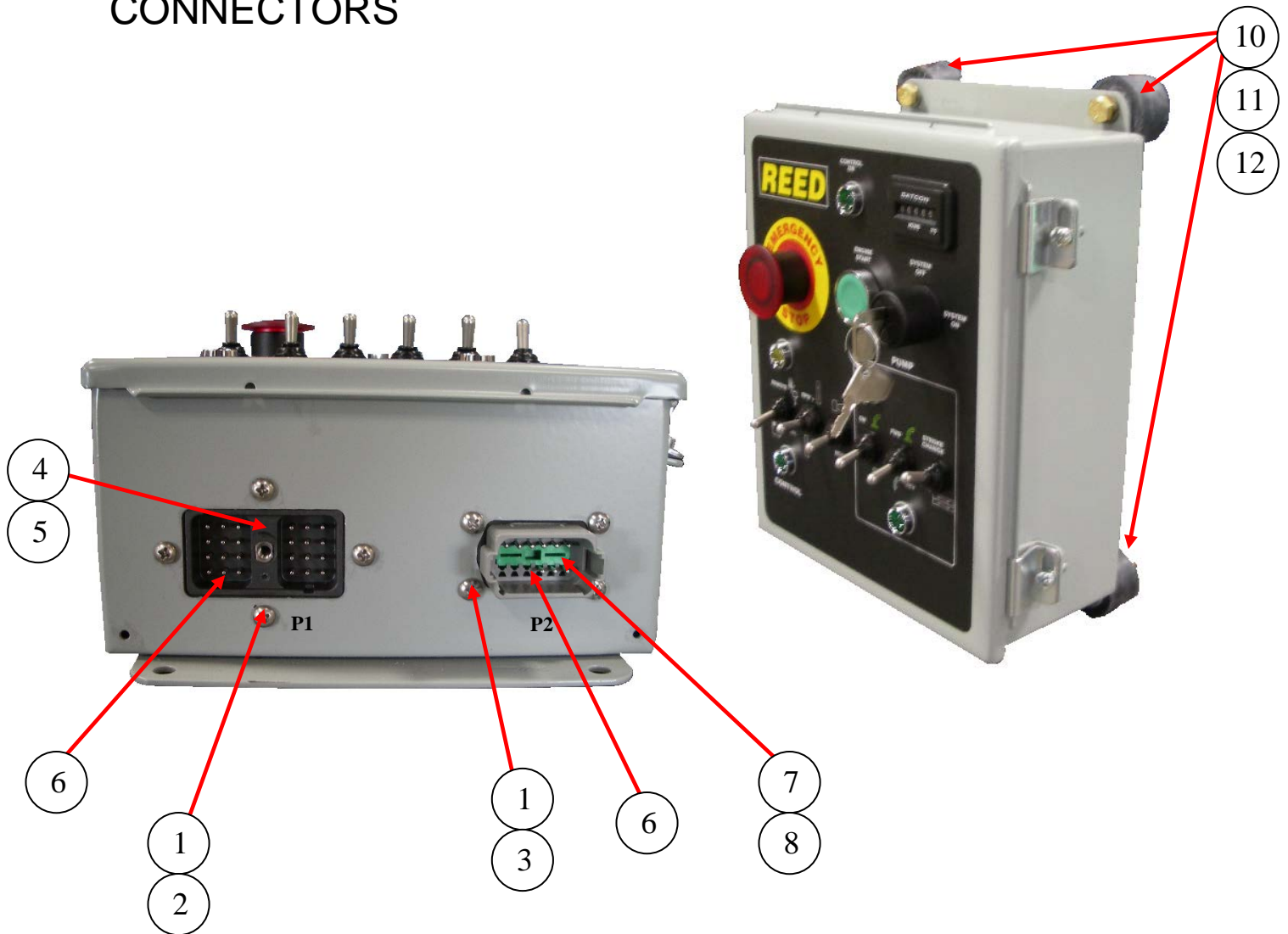

ID #	PART #	PART DESCRIPTION	QUANTITY	
1		NUT, 8-32 SELF LOCKING	8	EA
2		SCREW, 8-32X1.5" PHL	4	EA
3		SCREW, 8-32X1/2", PHL	4	EA
4	BW10217	CONN, DRC12-24PA (P1)	1	EA
5	BW10220	CONN,DRC24-GASKET	1	EA
6	BW10221	CONN PINS, (MALE)	33	
7	BW10218	CONN, DT04-12PA-L012 12 PIN FL MT	1	EA
8	BW10219	CONN, DT12-L012-GASKET	1	EA
10	73748	BUMPER	4	EA
11		BOLT, 5/16"-18 X 1/2"	4	EA
12		LOCKWASHER 5/16"	4	EA



A40HP PARTS

13822 Oaks Avenue
Chino, CA 91710
reedpumps.com
909-287-2100

50FT CABLE REMOTE



ID #	PART #	PART DESCRIPTION	QUANTITY	
1	BW10013	REMOTE CONTROL, CABLE 50FT, A-SERIES	1	EA



A40HP PARTS

13822 Oaks Avenue
Chino, CA 91710
reedpumps.com
909-287-2100

FRAME INSTALLATION FRAME, GAUGES, TIRES, JACK, AND TOW EYE

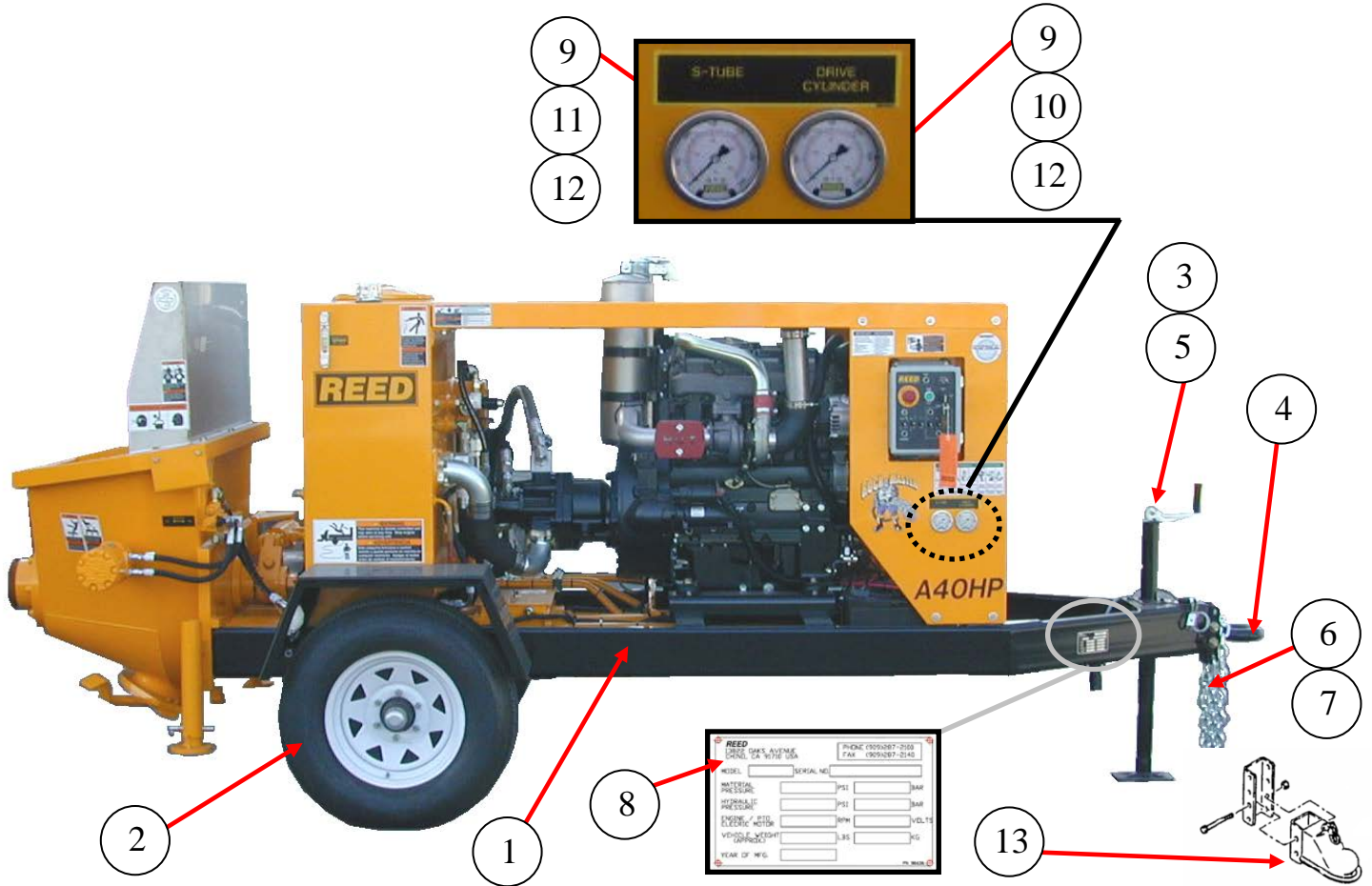

ID #	PART #	PART DESCRIPTION	QUANTITY	
	BW10404	FRAME ASSY A-SERIES 2008	1	EA
1	BW10398	FRAME WELDMENT A SERIES 2008	1	EA
2	BW10096	TIRE & WHEEL ASSY	2	EA
3	BW10098	JACK FRAME	1	EA
4	71051	EYE-LUNETTE 3"	1	EA
5	BW10169	JACK, FOOT	1	EA
6	86242	CHAIN-3/8 PROOF COIL GR 30 ZINC	6	FT
7	86243	CONNECTOR – 3/8 CHAIN TREADED	2	EA
8	86636	SERIAL NUMBER PLATE (BLANK)	1	EA
9	78594	MINICHECK GAUGE ADAPTER, 1/4" NPT	2	EA
10	74562	PRESSURE GAUGE, 6000 PSI/BAR	1	EA
11	70366	PRESSURE GAUGE, 3000 PSI/BAR	1	EA
12	BW10318	MINICHECK HOSE, 90° 48"	2	EA
13	71099	ASSEMBLY, ADJUSTABLE BALL COUPLER 2-5/16"	1	EA

5200LB AXLE MOUNTING ASSEMBLY

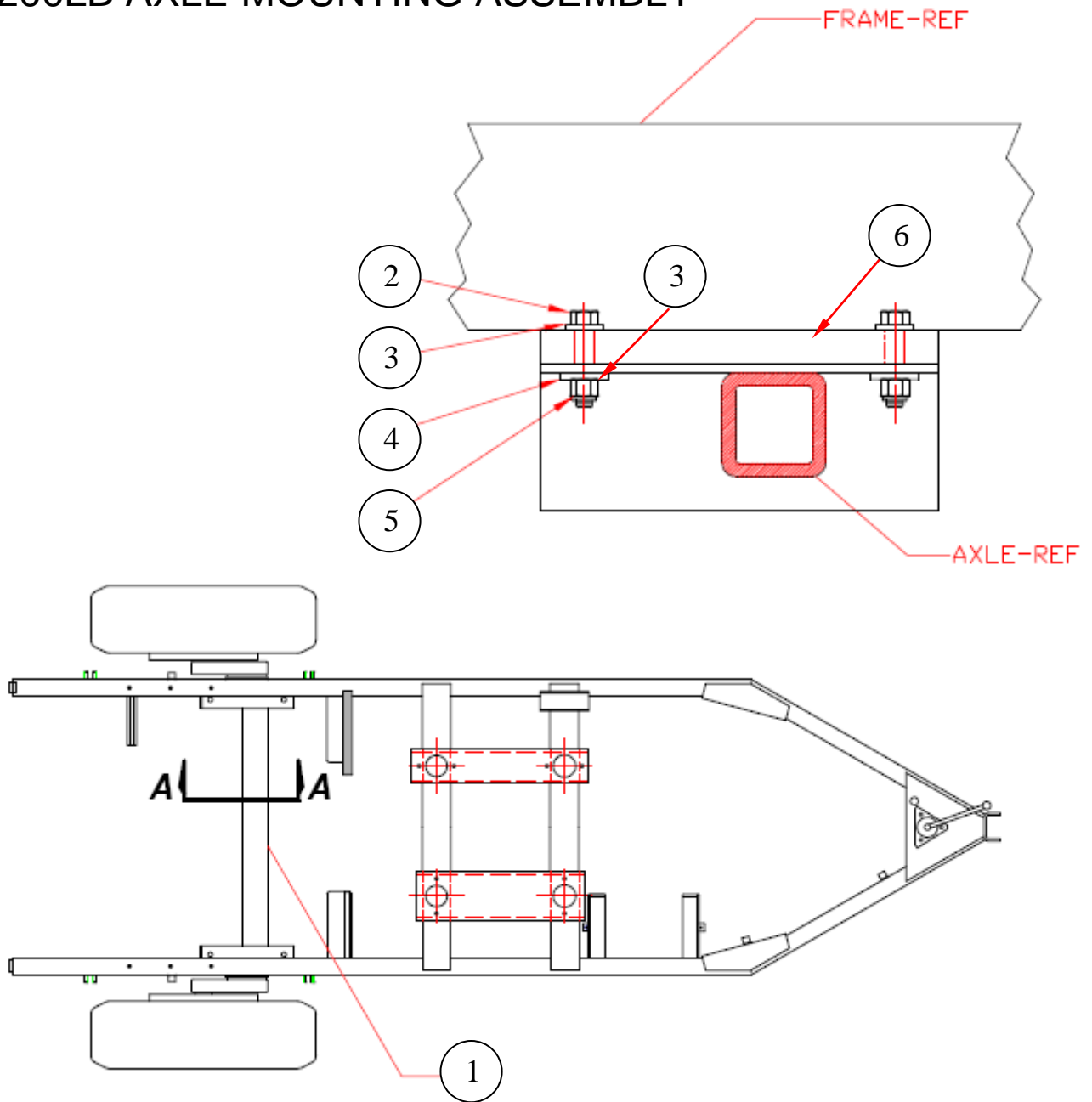

ID #	PART #	PART DESCRIPTION	QUANTITY	
1	BW10095	AXLE, TORSTION, 5200 LB, 6 ON 5.5	1	EA
2		BOLT, 1/2"-20X3", GRADE 8	4	EA
3	80054	WASHER -SAE 1/2"	8	EA
4	80044	WASHER, 1/2" USS HARDENED EXTRA THICK	4	EA
5	80075	NUT NYLOCK 1/2"-13 COARSE	4	EA
6	BW10450	FLAT AXLE MOUNT SPACER	2	EA

HOOD AND COVERS

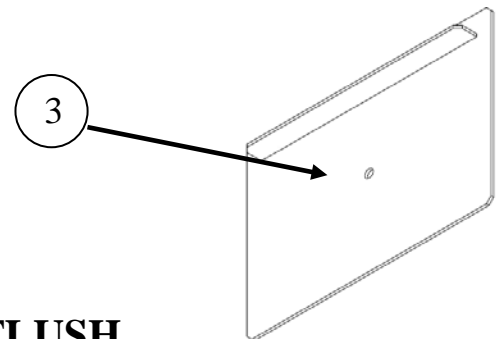
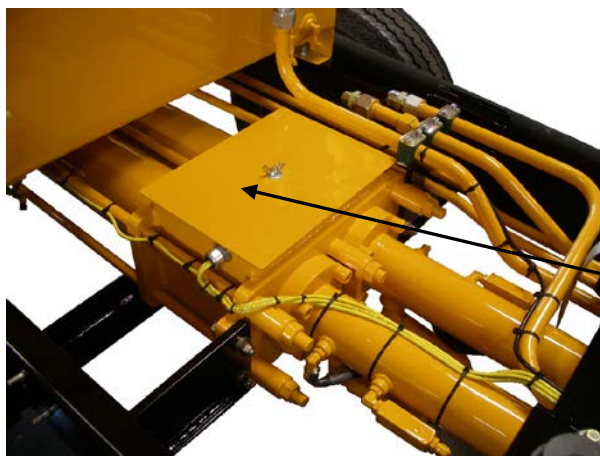
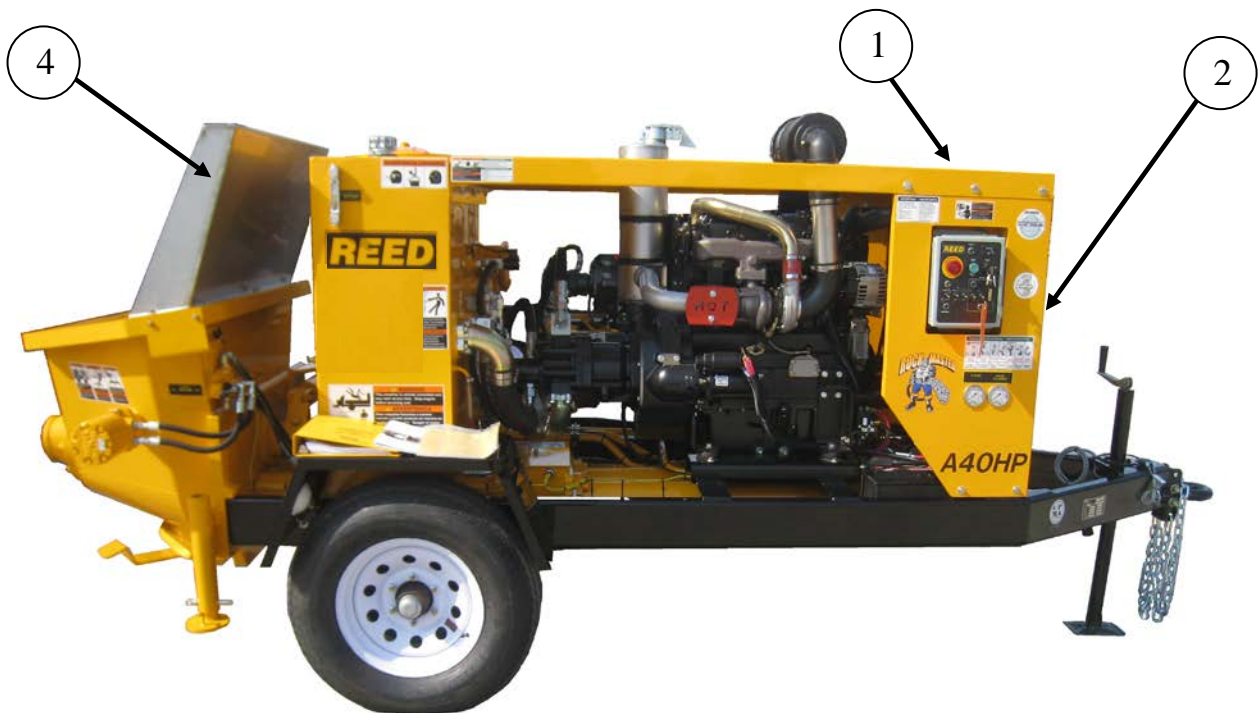

**FLUSH
BOX**

ID #	PART #	PART DESCRIPTION	QUANTITY	
1	BW10399	COVER TOP, B SER CUMMINS PAINTED	1	EA
2	BW10400	COVER FRONT WELD, B SER CUM PAINTED	1	EA
3	BW10388	LID, FLUSHBOX, A40	1	EA
4	85714-1	SPLASH GUARD, WITH HOPPER SAFETY	1	EA

FENDERS AND OUTRIGGERS



ID #	PART #	PART DESCRIPTION	QUANTITY	
1	BW10350	FENDER, LH, A SERIES PAINTED	1	EA
2	BW10349	FENDER, RH, A SERIES PAINTED	1	EA
3	BW10110	OUTRIGGER INNER LEG-PAINTED	2	EA
4	BW10114	OUTER TUBE, OUTRIGGER-PAINTED	2	EA
5	85595	PIN, Q/R, 5/8 DIA X 3 1/2 L	2	EA
6	800418	LANYARD, Q/R PIN	2	EA



A40HP PARTS

13822 Oaks Avenue
Chino, CA 91710
reedpumps.com
909-287-2100

OPTIONS MANUAL OUTRIGGERS



ID #	PART #	PART DESCRIPTION	QUANTITY	
1	BW10346	JACK WELDMENT, OP SIDE	1	EA
2	BW10347	JACK WELDMENT, NON OP SIDE	1	EA
3	85595	PIN, Q/R, 5/8 DIA X 3 1/2 L	2	EA
4	800418	LANYARD, Q/R PIN	2	EA

OPTION HYDRAULIC AGITATOR

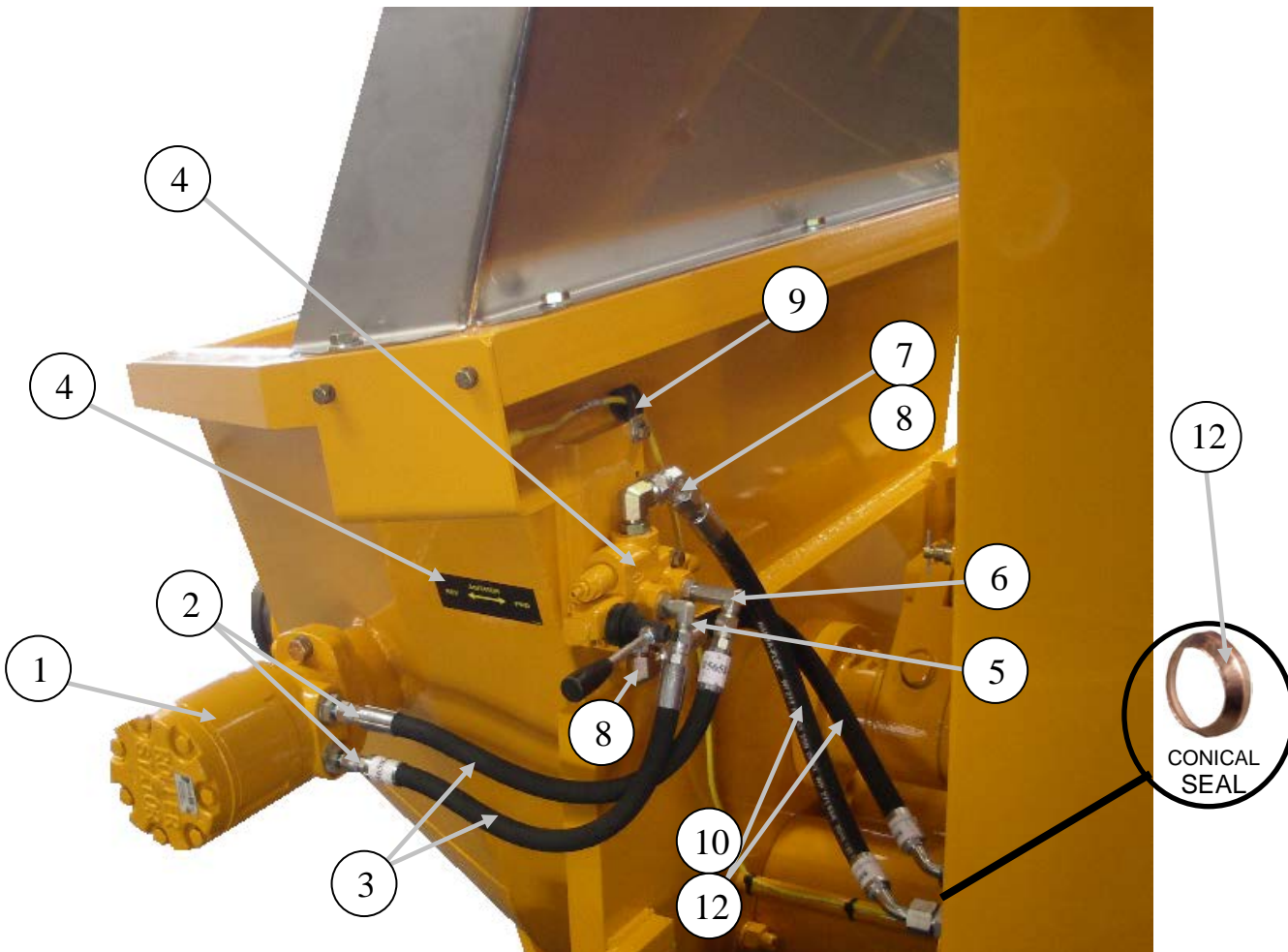

ID #	PART #	PART DESCRIPTION	QUANTITY	
	BW10396	AGITATOR ASSEMBLY, A40		EA
1	85811	HYD MOTOR, 45.6 CID, 1" SHAFT-PAINTED	1	EA
2	86866	FITTING-MB-MJ-10-6	2	EA
3	85658-002	HOSE, 6M2T-6FJX-6FJX-17.00	2	EA
4	74584	VALVE 1 SPOOL, MANUAL PAINTED	1	EA
5	86748	FITTING-MB-MJ90-6-6	1	EA
6	86747	FITTING-MB-MJ90LL-6-6	1	EA
7	86749	FITTING-MJ-FJX45-10-10	1	EA
8	86746	FITTING-MB-MJ90-8-10	2	EA
9	800897	CLAMP, 3/4" TUBE, SINGLE	1	EA
10	85657-016	HOSE, 8M2T-10FJX-10FJX45-20.00	2	EA
11	85846	DECAL, ADGITATOR	1	EA
12	BW10229	CONICAL SEAL, SIZE 12	4	EA
13	85657-024	HOSE, 8M2T-10FJX-10FJX90S-24.50 (UNDER TANK)	1	EA
14	BW10407	TUBE HYD. AGITATOR PRESSURE (UNDER TANK)	1	EA

OPTION HYDRAULIC AGITATOR CONT.

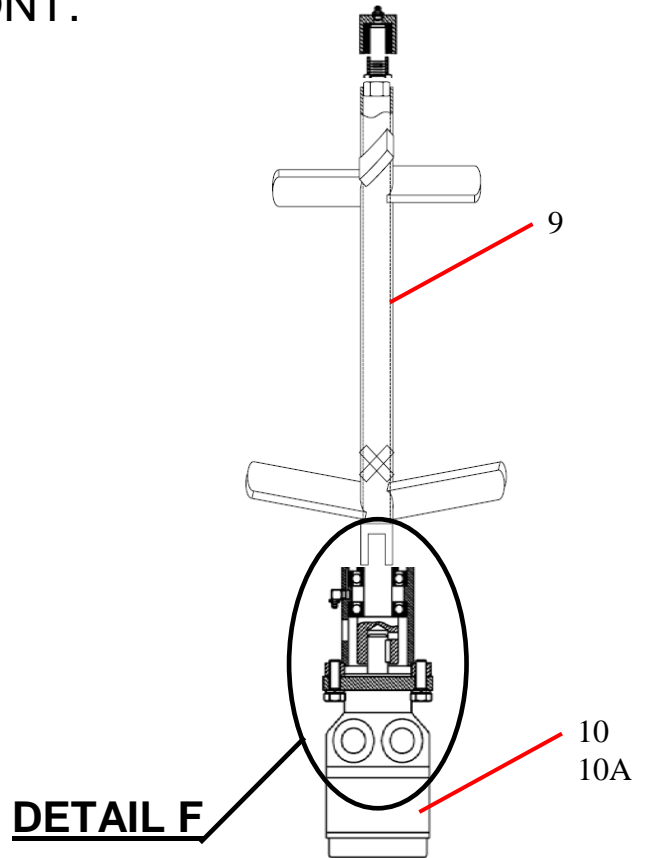
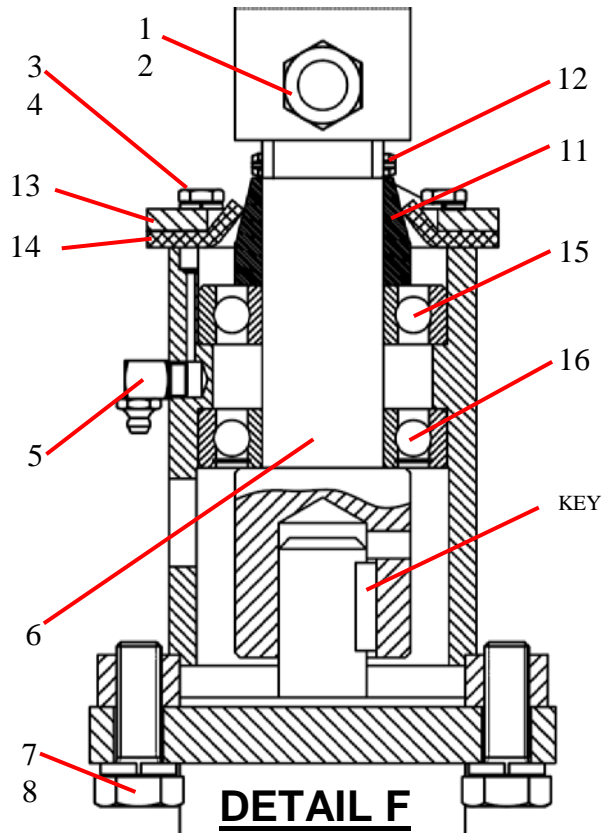

ID#	PART #	PART DESCRIPTION	QUANTITY	
	88041-A2	AGITATOR ASSEMBLY	REF	
1		HHCS, 1/2" -13X2 1/4" GR 8	1	EA
2		LOCK NUT, 1/2" -13	1	EA
3		1/4"-28X3/4"	6	EA
4		LOCK WASHER, 1/4"	6	EA
5		GREASE FITTING, 1/8" NPT 90°	1	EA
6	85923	SHAFT, AGITATOR	1	EA
7		HHCS, 1/2" -20X1 1/2" GR 8	2	EA
8		LOCK WASHER, 1/2"	2	EA
9	85717	AGITATOR, PADDLE-B20	1	EA
10	85811	HYD MOTOR, 45.6 CID, 1" SHAFT	1	EA
10A	85811SK	SEAL KIT	1	EA
11	85976	WEAR RING, AGITATOR	1	EA
12	86758	SPRING PIN, 1/4" DIA X 1 3/4"	1	EA
13	70211	FLANGE SEAL S/W	1	EA
14	70212	SEAL REMIXER	1	EA
15	85978	BEARING, BALL, PLAIN	1	EA
16	85979	BEARING, BALL 1 SEAL	1	EA

OPTION HYDRAULIC AGITATOR CONT.

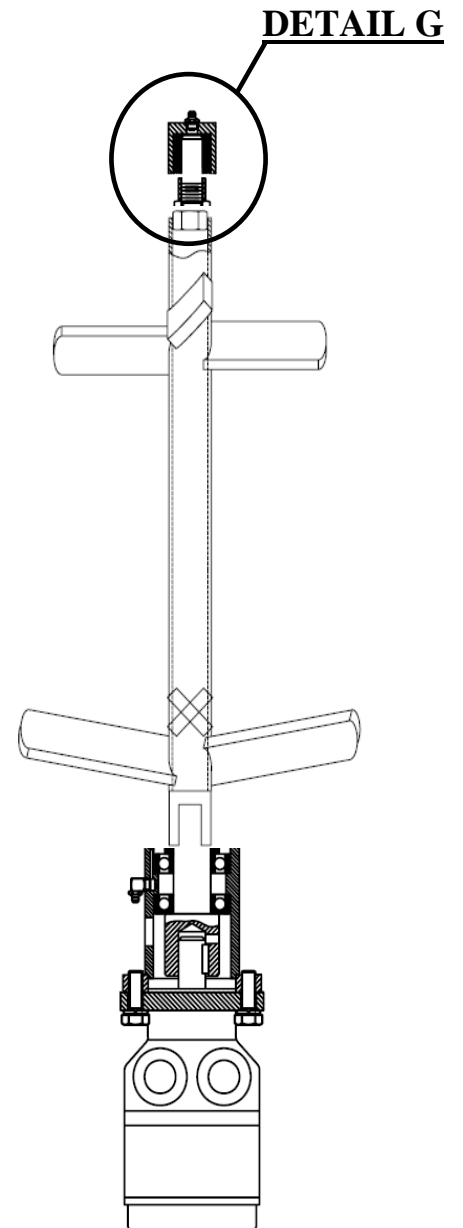
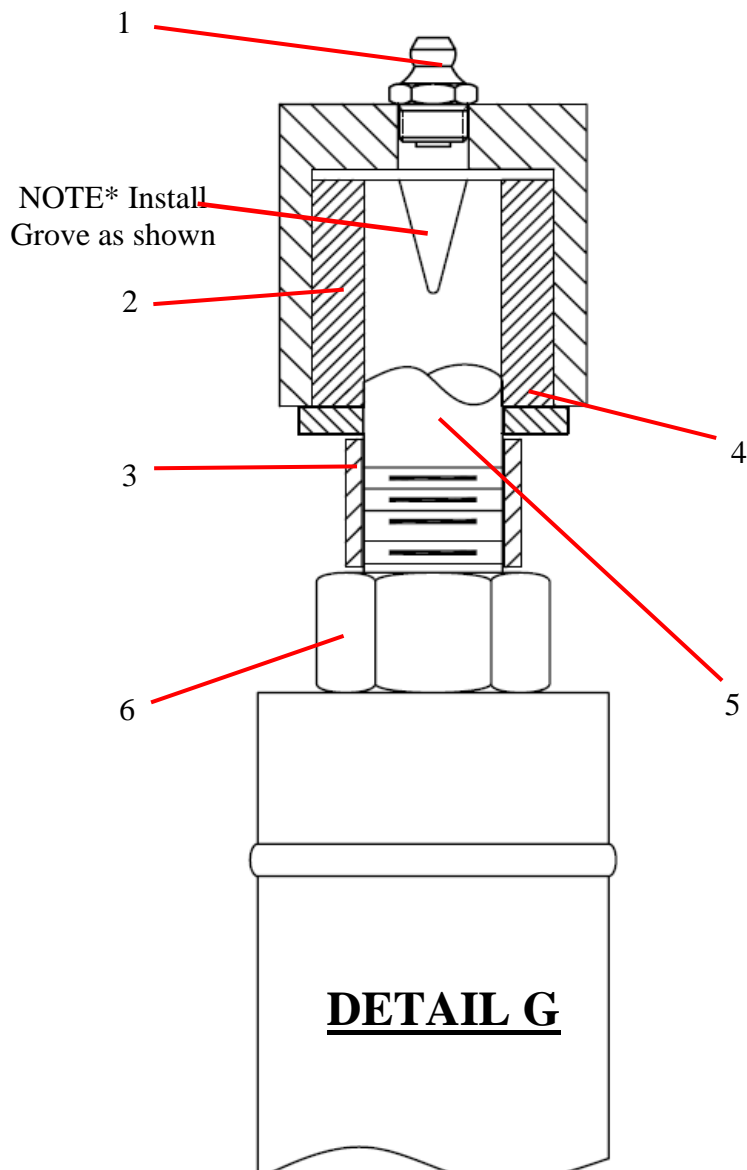

ID #	PART #	PART DESCRIPTION	QUANTITY	
1		GREASE FITTING, 1/8" NPT STRAIGHT	1	EA
2	70219	REMIX SHAFT BUSHING	1	EA
3	77877	SPACER, REMIX	1	EA
4	86824	FLAT WASHER, 3/4" SAE	1	EA
5	70214	IDLER SHAFT, AGITATOR	1	EA
6	80030	HEX NUT-M20X2.5 PLATED	1	EA

OPTIONS

AUTOLUBE PUMP (PLASTIC TUBING)



ID #	PART #	PART DESCRIPTION	QUANTITY	
1	87485-2	AUTOLUBE KIT	1	EA
2	87257	METAL GUARD	1	EA
3	78533	BLOCK, UNION, LINCOLN LUBE 12 PORT	1	EA

OPTIONS
AUTOLUBE PUMP (METAL TUBING)



OPTIONS

RADIO REMOTE KIT (BASE)



ID #	PART #	PART DESCRIPTION	QUANTITY	
	BW10188-001	RADIO REMOTE KIT, BASE	1	EA
1	BW10188-001T	TRANSMITTER, FOR BW10188-001	1	EA
2	BW10188-001R	RECEIVER, FOR BW10188-001	1	EA
3		RECEIVER CABLE	1	EA
4		ANTENA	1	EA
5		ANTENA CABLE	1	EA
6		12VDC CHARGING ADAPTER	1	EA

OPTIONS
CHROME WHEEL AND TIRE

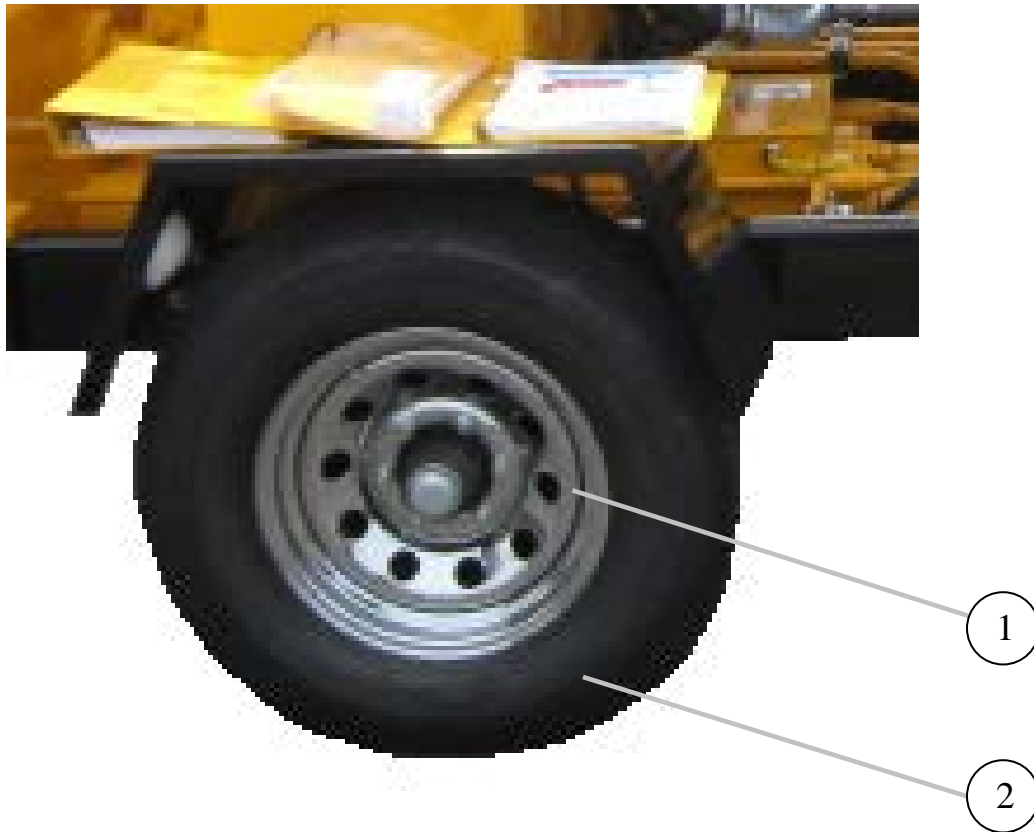

ID #	PART #	PART DESCRIPTION	QUANTITY	
	86059	TIRE & WHEEL-CHROME ASSEMBLY	2	EA
1		WHEEL-CHROME	2	EA
2		TIRE-9.50-16.5 LT LOAD E	2	EA



A40HP PARTS

13822 Oaks Avenue
Chino, CA 91710
reedpumps.com
909-287-2100

OPTIONS SURGE BRAKE ASSEMBLY



ID #	PART #	PART DESCRIPTION	QUANTITY	
	BW10312	ASSEMBLY, SURGE BRAKE-MODEL A30HP	REF	EA
1	BW10310	FRAME, MODIFICATION-SURGE BRAKE	1	EA
2	71025	ACTUATOR, SURGE BRAKE	1	EA
3	71052	HYDRAULIC BRAKE KIT-12 X 2	1	EA
4	87256	BRAKE LINE KIT	1	EA
5	71030	TORSION SPRING-BRAKES KIT	1	EA



A guide for the prevention of accidents when driving, operating, cleaning, and maintaining concrete pumps, placing booms, and related equipment.



American Concrete Pumping Association
606 Enterprise Drive
Lewis Center, OH 43035
614 431 5618
www.concretepumpers.com

REED

REED, LLC
13822 Oaks Avenue
Chino, CA 91710 USA
www.reedpumps.com

Version 5.0.1

CALIFORNIA

Proposition 65 Warning

Diesel engine exhaust and some of its constituents are known to the State of California to cause cancer, birth defects, and other reproductive harm.

SAFETY MANUAL

A GUIDE FOR THE PREVENTION OF ACCIDENTS WHEN DRIVING, OPERATING, CLEANING, AND MAINTAINING CONCRETE PUMPS, PLACING BOOMS AND RELATED EQUIPMENT

Introduction

Safety is one of the major concerns of every person involved in the concrete pumping industry. Although much of the responsibility for everyday safety rests upon the pump operator, it is vital that everyone involved makes safety the top priority. This includes the owners, the mechanics, the ready mix drivers, the placing crew, the concrete contractors and the machine manufacturers.

Although this Safety Manual covers a great deal of information regarding the prevention of accidents while operating a concrete pump or placing boom, it is unlikely that every conceivable circumstance has been covered. Regardless of how thorough a manual like this may be, there is always the unexpected. Please understand that there is no substitute for common sense and dedication to the idea that you are responsible for your own safety, and affect

the safety of those around you. You have to know the rules first, but you must keep your mind on the job if knowledge of the rules is going to keep you and your co-workers alive and well. No attempt has been made in this Safety Manual to provide the highly specialized knowledge of the workings of the individual machines that is also critical for safe and proper operation. For that, you must **read and understand the operation manual for the machine(s) that you operate!**

This Safety Manual is a guide for the prevention of accidents and is to be used in conjunction with **professional training**. Additional information and materials are available through the American Concrete Pumping Association, including, specifically, an Operators Certification Program. Make the commitment to be professional - get your certification!

Version 5.0.1

January, 2006

© Copyright 1992, 1993, 1999, 2000, 2003, 2006

CPMA, All rights reserved.

SAFETY MANUAL

Table of Contents

Introduction	iii
General Rules	1
Table of Contents	1
I. Before You Leave The Yard	2
1. Safety Alert Symbol And Signal Word Explanation	2
2. What To Do Before You Arrive At Work	2
3. What To Check Before You Leave The Yard	4
4. Safety Rules For Driving Truck Mounted Concrete Pumps	8
5. Safety Rules For Towing Trailer Mounted Concrete Pumps	10
II. On The Job site	12
6. Safety Rules For Job Setup	12
7. Setting Up A Trailer Mounted Pump and/or A Separate Pipeline	27
III. Concrete Pump Operation.	32
8. Safety Rules For Pump Operators	32
IV. Cleaning The Pump And System	44
9. Safety Rules For Cleaning The Boom	44
10. Safety Rules For Cleaning The Concrete Valve & Hopper.	44
11. Safety Rules For Cleaning The Water Box	45
12. Safety Rules For Cleaning A Separately Laid Pipeline	46
V. Maintenance Of The Machinery	51
13. Safety Rules Regarding Inspection	51
14. Safety Rules Regarding Scheduled Maintenance	52
15. Safety Rules When Servicing The Machinery.	53
VI. Co-worker Safety	57
16. Safety Rules For Workers Assigned To The Pump.	57
17. Safety Rules For The Placing Crew.	64
Appendix	71
VII. Weld On Ends / Coupling Comparison	72
VIII. Minimum Pipe Wall Thickness Chart	73
IX. Glossary Of Terms	74
X. Recommended Hand Signals	80
XI. Bibliography	80
Alphabetical Index.	81

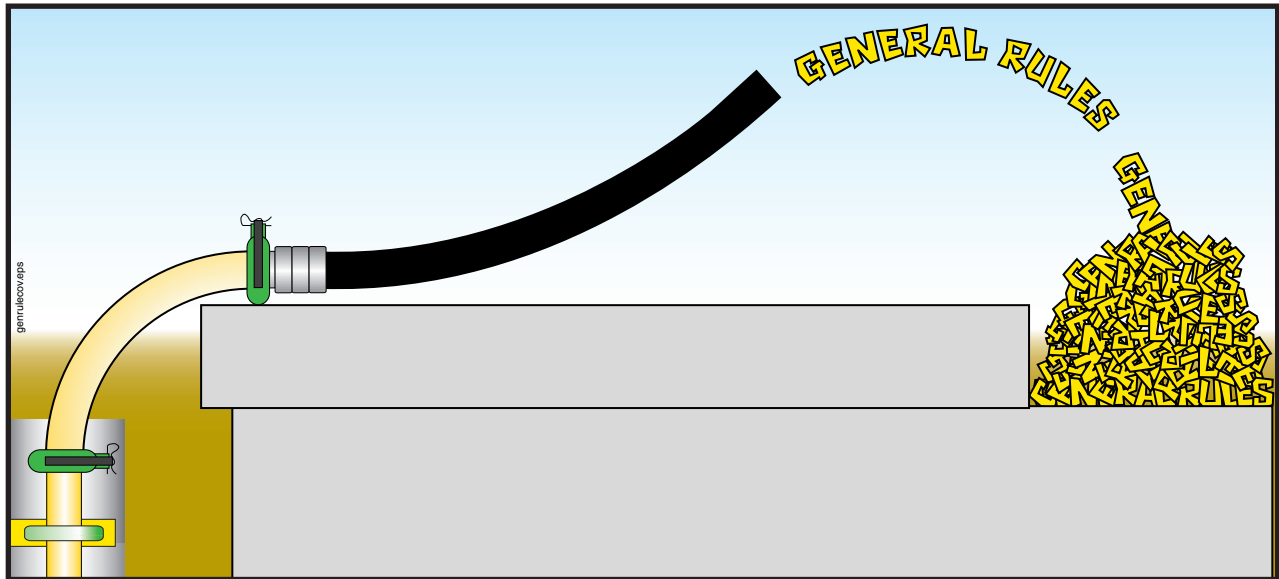

General Rules Table of Contents

I.	Before You Leave The Yard	2
1.	Safety Alert Symbol And Signal Word Explanation	2
2.	What To Do Before You Arrive At Work	2
3.	What To Check Before You Leave The Yard	4
4.	Safety Rules For Driving Truck Mounted Concrete Pumps	8
5.	Safety Rules For Towing Trailer Mounted Concrete Pumps	10
II.	On The Job site	12
6.	Safety Rules For Job Setup	12
7.	Setting Up A Trailer Mounted Pump and/or A Separate Pipeline	27
III.	Concrete Pump Operation	32
8.	Safety Rules For Pump Operators	32
IV.	Cleaning The Pump And System	44
9.	Safety Rules For Cleaning The Boom	44
10.	Safety Rules For Cleaning The Concrete Valve & Hopper	44
11.	Safety Rules For Cleaning The Water Box	45
12.	Safety Rules For Cleaning A Separately Laid Pipeline	46
V.	Maintenance Of The Machinery	51
13.	Safety Rules Regarding Inspection	51
14.	Safety Rules Regarding Scheduled Maintenance	52
15.	Safety Rules When Servicing The Machinery	53
VI.	Co-worker Safety	57
16.	Safety Rules For Workers Assigned To The Pump.	57
17.	Safety Rules For The Placing Crew	64

I. Before You Leave The Yard

1. Safety Alert Symbol And Signal Word Explanation





1.1



The triangle with the exclamation point inside is used to alert you to an important safety point, and is called a *Safety Alert Symbol*. One of the following color-coded signal words will appear after the safety alert symbol:



or - without
the symbol: 

- If the safety alert symbol is followed by the signal word **DANGER** with white letters in a red box (), it indicates a hazardous situation which, if not avoided, **WILL** lead to **death or serious injury**.
- If the safety alert symbol is followed by the signal word **WARNING** with black letters in an orange box (), it indicates a potentially hazardous situation which, if not avoided, **COULD** result in **death or serious injury**.
- If the safety alert symbol is followed by the signal word **CAUTION** with black letters in a yellow box (), it indicates a potentially hazardous situation which, if not avoided, **COULD** result in **minor to moderate injury**.
- The signal word **CAUTION**, used in a yellow box, but **without the safety alert symbol** (), means the point addresses a hazard which, if not avoided, **COULD** cause **damage to equipment or property**.

2. What To Do Before You Arrive At Work

2.1

Get enough sleep to be ready for the day's work. Accidents can happen when the body is on the job, but the mind is not.

Dress in appropriate apparel and Personal Protective Equipment (P.P.E.) (see Figure 1). You should always wear these items when pumping concrete:

- hard hat
- safety glasses or goggles
- snug fitting clothes
- gloves
- steel toed shoes

In addition, you should wear:

- hearing protection if you stand near the pump
- breathing mask when mixing slurry or whenever there is cement dust in the air

- rubber gloves during cleanout
- rubber boots anytime you have to stand in concrete

Jewelry, athletic shoes, sandals, and shorts are examples of clothing that should NOT be worn when pumping.

* Breathing mask needed when cement dust (or other toxic dust) is present in the air.



Figure 1
Personal Protective Equipment (P.P.E.)

2.2

⚠ WARNING Be sure that any clothing you wear does not have strings, fringes, or other external tightening means that could be caught in moving parts (Figure 2).

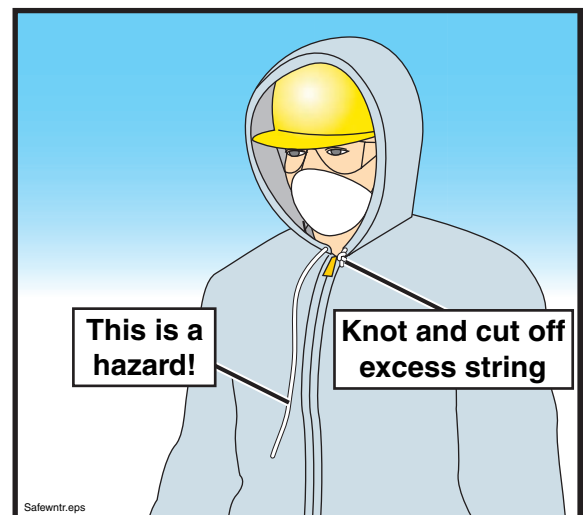

Figure 2
No strings attached

SAFETY MANUAL

2.3 Arrive to work on time. Accidents can be caused by hurrying through procedures.

2.4 **⚠ WARNING** Never go to work on a construction site or work on, around or near a piece of machinery when under the influence of drugs or alcohol. Beware of “over the counter” drugs, many of which have specific warnings about operating machinery after taking the medication (Figure 3).



Figure 3
Your co-workers depend upon you for their safety

2.5 **⚠ WARNING** Don't bring your personal problems to work with you. In an office setting this may be annoying to co-workers, but on a construction site it can be deadly. The workers around you depend on you for their safety.

3. What To Check Before You Leave The Yard

3.1 **⚠ WARNING** Do not operate the machine until you read and understand the unit's operation manual. Lack of understanding of proper operating procedures could result in unsafe operation. Operation manuals are issued with each new unit. If you haven't seen it, ask your supervisor. Replacements are available from the manufacturer.

3.2 **⚠ WARNING** Inspect delivery pipes, concrete delivery hoses, and end hoses for wear. Never use a worn hose or worn or dented pipe. **Know the maximum pressure that your machine can exert on the concrete, and be sure that the pipes, hoses and clamps are capable of handling the pressure.** Maximum pressure on concrete is stated in operation manuals, service manuals, and on the serial number plate of the machine. A chart showing the minimum wall thickness of pipeline versus maximum pressure is found on page 73 in the appendix section of this Safety Manual.

3.3 **⚠ WARNING** If you will need to use compressed air to clean out the boom or system pipeline, BE SURE that you have the proper training, equipment, and attachments to do this procedure safely! Proper attachments include:

- A blow out head with properly sized air discharge regulator valve and separate water/air inlet. The two openings should be spaced apart far enough that a blowout ball could not cover both openings at once.
- A *go devil*, or a hard sponge ball. Regardless of which is used, it **must** fit into the pipeline tight enough that air cannot escape ahead of it.
- A ball or go devil catcher that will catch the go devil or ball when the line has been purged of all concrete. There are two types of catchers (see paragraph 7.23 on page 31).
- A hose that is rated for the pressure of the air compressor you will use and that is able to connect with both the air compressor and the blow out head. The hose must be in good working condition and must be free of cracks, frays, tears or other damage. Do **NOT** improvise on this. **Make sure** that you have the right part (Figure 4).

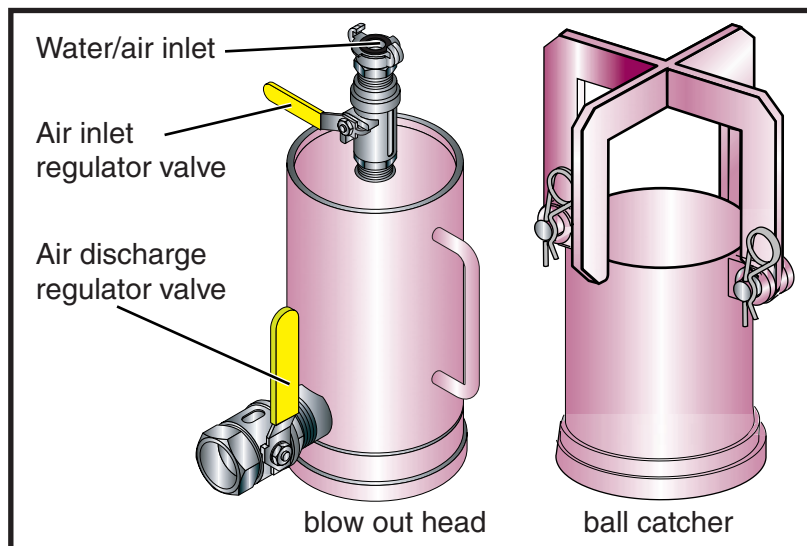

Figure 4
Compressed air accessories

- 3.4** **⚠ WARNING** Be sure that the unit is equipped with all the pipes, clamps, gaskets and hoses, blow out adapters, ball catchers, and other accessories that you will need for the day's work. "Making do" with inappropriate equipment could cause accidents.
- 3.5** On trailer mounted units, check the oil and cooling system (air or water cooled systems) of the pump drive engine. Accidents could occur when lack of maintenance is causing a distraction while operating the equipment.
- 3.6** Be sure the battery has enough charge to start the pump drive engine. You will be rushed on the job if you have to do repair work before you can begin operation.

SAFETY MANUAL

- 3.7** **⚠ WARNING** The operator is responsible for checking to see that the concrete pump, placing boom, and delivery system are in safe and proper working condition. If an unsafe condition exists, **work must not begin** until necessary repairs have been completed, or until the machine can be operated safely.
- 3.8** **⚠ WARNING** The operator is responsible for checking that all safety equipment and guards are in place and in good condition. If found to be missing, incomplete, or damaged, **work must not begin** until the situation has been made safe.
- 3.9** **⚠ WARNING** The operator is responsible for checking that all safety decals are in place and are in readable condition. If found to be missing or unreadable for any reason, steps should be taken to obtain replacements.
- 3.10** **⚠ WARNING** Inspect the tires and brakes on the truck. Never drive a truck with bald or cracked tires, or with weak or worn brakes. If you have air brakes, be sure that the air system is free from leaks and will maintain pressure when driving. Loss of air pressure will cause the brakes to be applied while driving. If driving continues after the brakes are applied, the resulting friction could cause enough heat to start a fire.
- 3.11** Drain moisture from the air tanks that supply the unit's brakes (if so equipped). This is especially important if weather conditions could cause the moisture to freeze. If you lose air pressure because of frozen moisture, the brakes will apply themselves, and you will have to stop driving until the unit is repaired.
- 3.12** **⚠ WARNING** (See Figure 5.) Mount or dismount the pump or truck using the *3 Point Rule* (i.e. keep two hands and one foot or one hand and two feet in contact with a secure surface at ALL times).

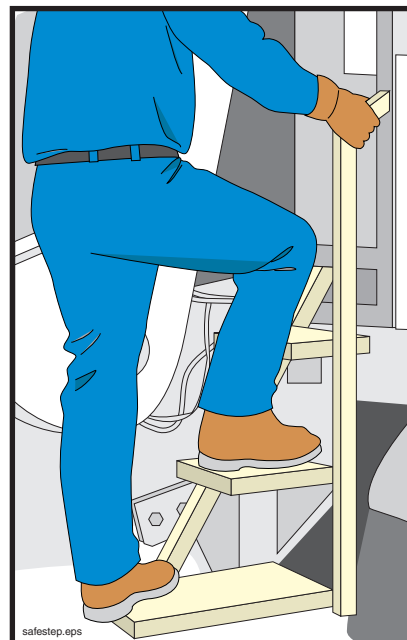



Figure 5
The 3 Point Rule

3.13  **WARNING** Never mount or dismount the truck or pump while carrying objects that prevent you from using the “3 Point Rule.” Move the objects separately, if needed.

3.14  **WARNING** Be sure that outriggers are pinned and locked before traveling. If the locking device is damaged or worn, it should be repaired immediately and the unit **must not be driven until the outriggers can be positively locked** against accidental opening (see Figure 6).

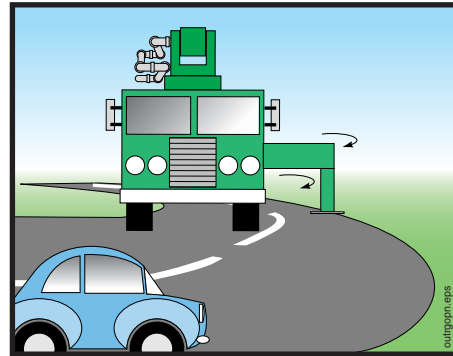





Figure 6
Before driving, be sure
outriggers cannot open

3.15  **WARNING** Be sure there is nothing in the cab of the truck (such as empty soda cans, loose tools, etc.) that could interfere with the operation of the vehicle.

3.16 Be sure that all road-related safety devices (warning signs, flares, fire extinguisher, etc.) are present and secured for travel.

3.17 Be sure all personal protective equipment (hard hat, safety goggles, rubber gloves, etc.) are secured for travel.

3.18  **WARNING** Be sure the windshield and mirrors are clean and free of frost or ice, and that the mirrors are properly adjusted.

3.19  **WARNING** Verify that head lights, tail lights, turn signals, brake lights, backup warning horn, and backup lights are operational.

3.20 In some cases you may be asked to operate a machine other than the one with which you are familiar. In these cases, be sure to:

- Know the weight, height, and width of the machine.
- Have a copy of the operation manual with you.
- Ask the machine’s normal operator, the dispatcher, or your supervisor questions regarding any unusual or unique operational characteristics of the machine.
- Familiarize yourself with the machine by setting it up in the yard and running the functions, and by familiarizing yourself with the operation manual. This is especially important if the new machine is significantly different than the one you normally operate. Your co-workers depend on you to know the machine.

SAFETY MANUAL

3.21

⚠ WARNING Before driving the unit, be sure the boom is securely in its cradle, resting on approved boom rests that are in good condition, and secured by the tie-down strap (if so equipped). On some makes and models, the boom can be damaged by the bouncing motion that occurs while driving, but this damage is easily avoided by using the strap (Figure 7).

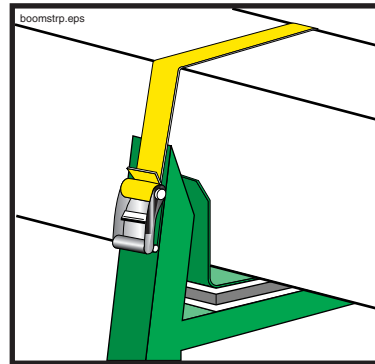

Figure 7
If your unit has a boom strap, use it

3.22

⚠ WARNING Be certain that all loose items on the unit are secured for travel before driving.

4. Safety Rules For Driving Truck Mounted Concrete Pumps

4.1

⚠ WARNING **Electrocution hazard!** (See figure 8.) If you're going to drive under low-hanging overhead power lines and it is not possible to maintain adequate safety distance between the pump and the wires, **you should look for another route!** If none is available, contact the power company responsible for the lines and have them de-energized.

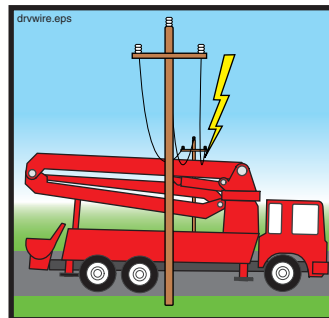

Figure 8
Watch for low-hanging power lines

4.2

Carefully select your route of travel. Avoid steep hills, residential areas, construction, low overpass clearances and narrow bridges whenever possible. **The driver is responsible for knowing the weight and height** of the machine.

- 4.3 **⚠ WARNING** Collision/falling hazard! Before driving on bridge or elevated roadways, be sure that they can support the weight of the vehicle (Figure 9).

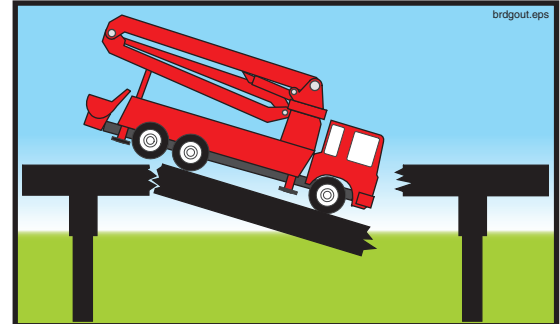
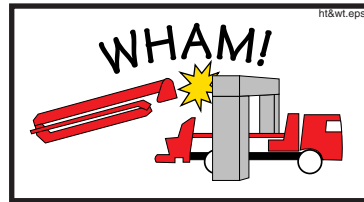

Figure 9
Know your height and weight

- 4.4 **⚠ WARNING** Collision hazard! Before driving under ANY structure, **BE SURE** that the machine will clear (Figure 9).

- 4.5 **⚠ WARNING** Explosion hazard! Never refuel the unit near hot surfaces, sparks, or open flames (Figure 10).



Figure 10
Be careful when refueling

- 4.6 **⚠ WARNING** Tipping hazard! The vehicle must **not** be driven with an unfolded placing boom.

- 4.7 **⚠ WARNING** Possible boom movement. Before driving the unit be sure that the distribution gearcase (PTO) has **disconnected** the hydraulic pumps. **Driving with the hydraulic pumps engaged creates a hazard** and is destructive to the pumps.

- 4.8 **⚠ CAUTION** Never drive the unit with concrete in the hopper. Concrete could splash out and damage other cars or property.

- 4.9 **⚠ WARNING** Runaway truck hazard! When going down a hill, use one gear lower going down than it would take to go up.

SAFETY MANUAL

- 4.10 **WARNING** Truck mounted concrete pumps are generally top-heavy. Use caution when making sharp turns with the vehicle (Figure 11).

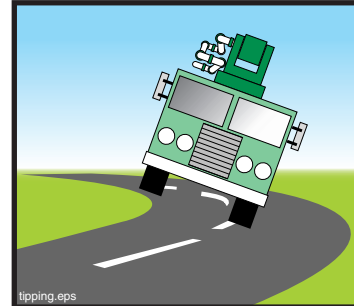

Figure 11
Maintain control on the curves

- 4.11 **WARNING** Slow down at intersections, near playgrounds, residential areas, and near schools. Children have no knowledge of the increased stopping distances required by heavy vehicles.
- 4.12 **CAUTION** Be familiar with your emergency equipment. Know how to light a flare, etc.
- 4.13 **WARNING** Drive defensively. You are at a distinct disadvantage when it comes to maneuverability and stopping distance.
- 4.14 **CAUTION!** If you must tow the unit, know the correct places to hook the towing cable(s). Improper towing can damage the vehicle or pump.
- 4.15 **WARNING** Never back up without a guide.
- 4.16 **CAUTION** Know the rules and laws that apply to your state and locality. They have been enacted for your protection and the protection of those around you.

5. Safety Rules For Towing Trailer Mounted Concrete Pumps

- 5.1 **WARNING** Be sure the towing vehicle is heavy enough and has enough horsepower and braking ability to tow the trailer. This is critical to maintaining control at highway speeds and to braking ability. If the trailer is heavier than the towing vehicle, braking distances will be greatly increased (Figure 12).

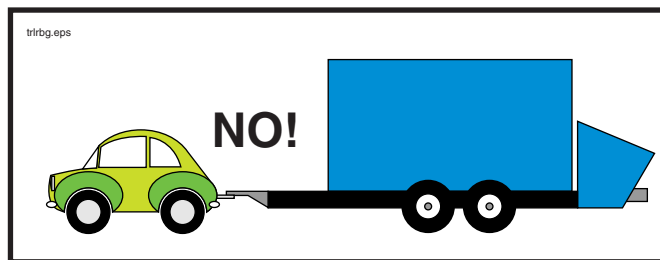

Figure 12
Do not under size the towing vehicle

- 5.2 **⚠ WARNING** Check the tires, tire pressure, and brakes on the trailer before towing. Never tow a vehicle with cracked or bald tires. A trailer tire blowout can cause loss of control in the towing vehicle.
- 5.3 **⚠ WARNING** Be especially careful on ice or slippery roads when towing a trailer. A skid that would normally be easily correctable can be multiplied by the trailer, causing loss of control.
- 5.4 **⚠ WARNING** Be sure that the electrical connections between the towing vehicle and the trailer are sturdy and reliable, and that the lights on the towing vehicle and trailer are working.
- 5.5 **⚠ WARNING** Always use safety chains and break-away protection when towing a trailer.
- 5.6 **⚠ CAUTION** Be aware of local or state regulations regarding mirrors and lights when towing a trailer.
- 5.7 **⚠ WARNING** When towing a trailer, your stopping distance and turning radius are greatly increased. Be aware of this **at all times**.
- 5.8 **⚠ WARNING** When towing a trailer long distances, it is important to check the hitch, wiring, and safety chains frequently.
- 5.9 **⚠ WARNING** Be aware of your length when towing a trailer. A common cause of trailer accidents is turning too close to curbs or objects.
- 5.10 **⚠ WARNING** Never back up a trailer without a guide.

II. On The Job site

6. Safety Rules For Job Setup

SETTING UP A TRUCK MOUNTED BOOM PUMP

- 6.1 **The job setup phase can set the stage for accidents.** Taking a few extra moments to correctly set up the job will improve your chances of having a safe, trouble-free day.
- 6.2 **The operator is responsible for the safe operation of the machine.** Notify your employer, the job superintendent, and/or O.S.H.A. if you are being asked to set up in an unsafe manner. **You are never required to take a chance with safety.** You are the **only** person who can determine that the job circumstances under your control are safe.
- 6.3 Canadian law requires that the boom remains a minimum of 7 meters from electric wires. To conform to the Canadian law, any text in this manual that refers to a 17 foot or 5 meter safety distance from electric wires should be read as 7 meters for use in Canada.
- 6.4 **⚠ DANGER** When overhead wires are in the area that the boom will be moving to complete a pour, a spotter must be employed whose only job is to warn the operator if the boom comes within 17 feet of the wires. The spotter must understand the responsibilities assigned, and must be able to judge a 17 foot distance.
- 6.5 **⚠ DANGER** You **MUST** avoid hazardous proximity or contact with electric lines at all times! Position the machine so a minimum safety distance of 17 feet (5 meters) is maintained in all boom positions needed to do the job (Figure 13). **Never decrease the safety distance to reach an unsafe area with the boom.**

Figure 13
Always maintain the safety distance

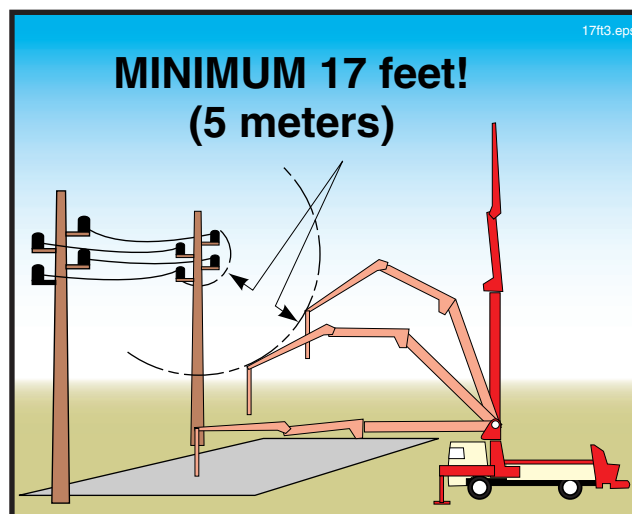

6.6

⚠ DANGER If you are in doubt about your proximity to high voltage wires, or if it is not possible to maintain 17 feet of clearance, you must lay a separate pipeline or use a different placement method. **Never take chances with high voltage!** (See Figure 14.)

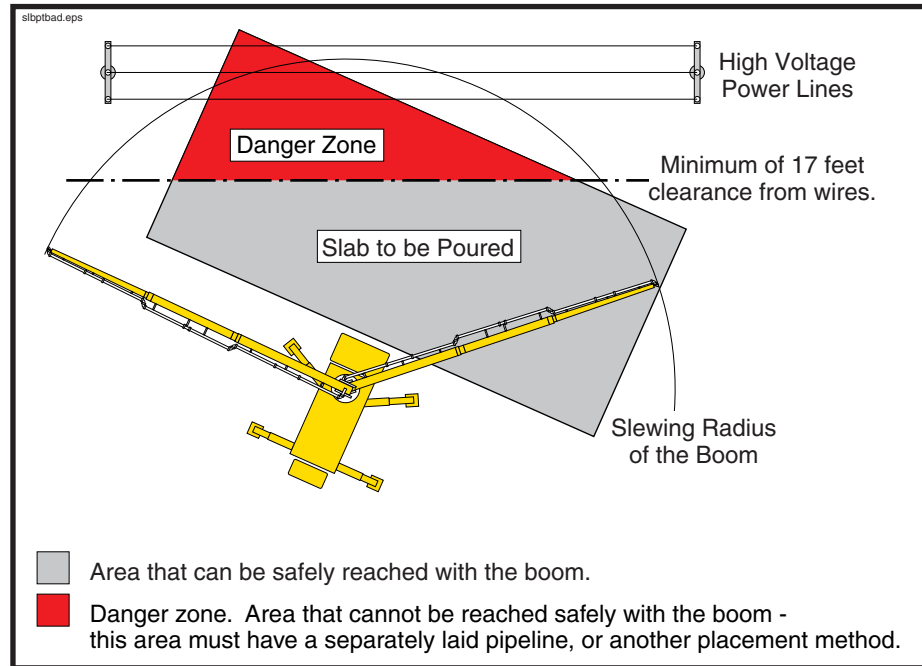

Figure 14

Lay a separate pipeline if you can't maintain the safety distance

6.7

⚠ DANGER Do not put the boom on top of electrical wires, even if you can maintain 17 feet of clearance. Mechanical or hydraulic malfunction may cause the boom to move down (Figure 15).

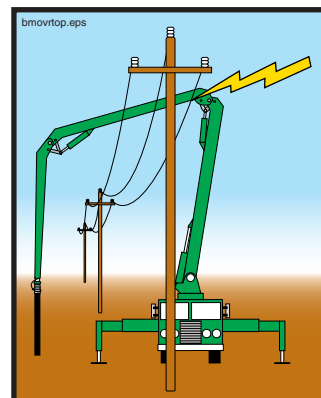

Figure 15

Never boom over wires

SAFETY MANUAL

6.8

⚠ DANGER It is crucial to take electric wires into consideration during setup, even if they are away from the area to be pumped! Accidents may occur during cleanout and moving that can be avoided by proper initial setup. In the illustrations below, the pour is outside of the minimum safety distance, but the danger still exists. You **must** be aware of the wires at all times! (See Figure 16.)

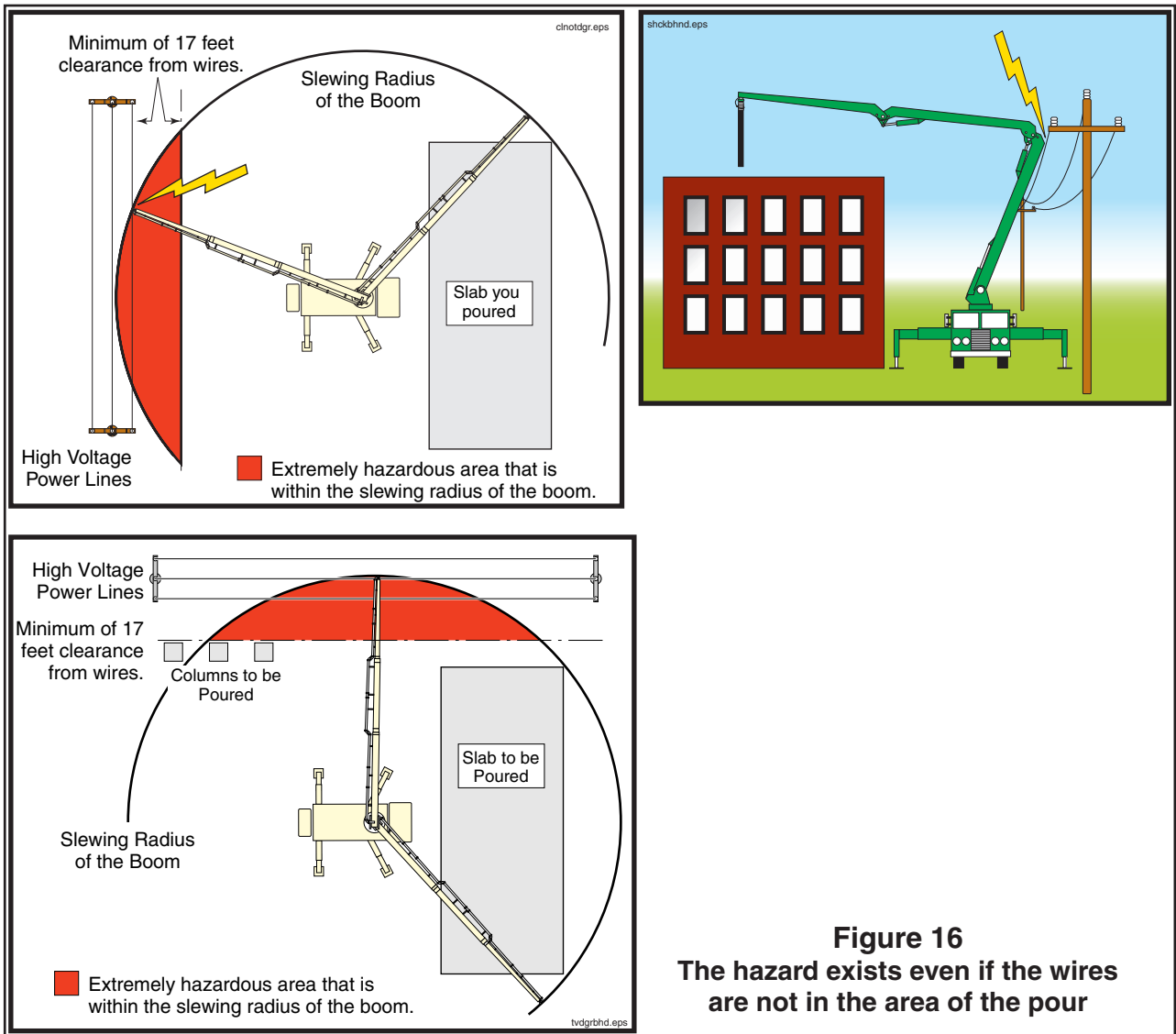



Figure 16
The hazard exists even if the wires are not in the area of the pour

6.9

⚠ DANGER Depth perception varies from person to person and is affected by the distance from the objects being observed. Minimum distances from electrical wires and other obstructions should always be judged by placing yourself in a viewing position that does not require depth perception judgements. If this is not possible, a spotter **must** be used! See the glossary for the definition of spotter (Figure 17).



Will it hit the wires?
You can't tell from here.

Get the best possible vantage point

From the vantage point of this operator, it would be extremely difficult to tell if the end of the boom will contact the electric wires.

The operator should stand in this position. If this is impossible, a spotter **MUST** be used. **DO NOT RELY ON DEPTH PERCEPTION WITH HIGH VOLTAGE WIRES!**

Figure 17
Never rely on depth perception with electric wires

SAFETY MANUAL

6.10

⚠ DANGER Always assume that a power line is live. Never take the word of someone on the job site that it has been de-energized. **Only a qualified representative of the responsible power company can verify that a line has been de-energized** (see Figure 18).

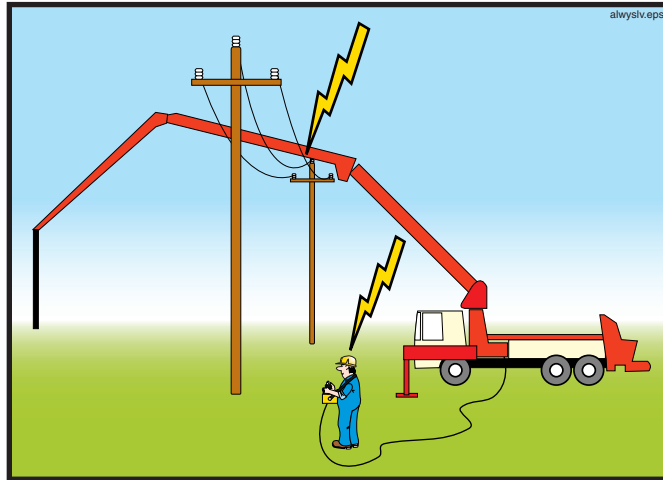

Figure 18
Assume the wires are energized

6.11

⚠ WARNING Maintain a safe distance from obstructions, such as cranes, scaffolding, and buildings (Figure 19).

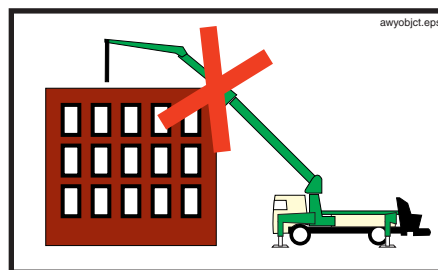

Figure 19
Maintain a safe distance from obstructions

6.12

⚠ WARNING Place wheel chocks under the tires on sloping terrain. Release the brakes and allow the machine to settle against the chocks, then reapply the brakes.

6.13

⚠ CAUTION Remove any snow, ice, oil, or dirt from steps and platforms.

6.14

⚠ WARNING Possible boom damage! Never add extensions to the end of the placing boom! If continuation pipes are connected to the end hose, they must **NOT** impose any load on the boom (Figure 20).

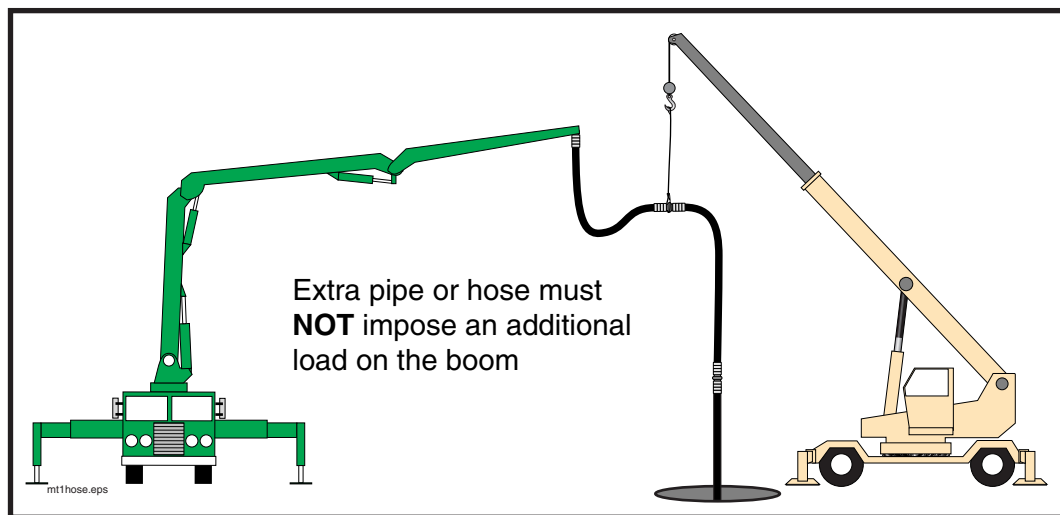
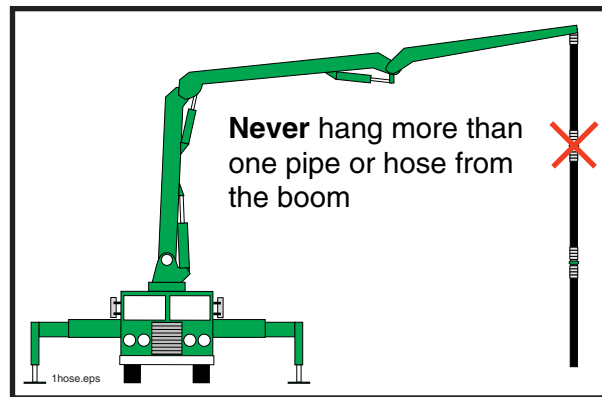

Figure 20
Know and do not exceed the maximum weight allowed to hang from the boom

6.15

⚠ WARNING The length of a 125mm boom end hose may not exceed 13 feet (4 meters). Certain machines may require a shorter length or smaller diameter end hose. Check with the boom manufacturer.

SAFETY MANUAL

6.16

⚠ WARNING Possible structural damage. If you remove the supplied tip hose and replace it with a combination of reducers and hoses, the total weight of all hanging pieces (including the weight of the concrete) must not exceed the weight of the supplied tip hose (including concrete). The supplied tip hose is typically 12 feet long and 125mm (or 5 inch) diameter. When filled with normal, hard rock concrete it weighs 376 pounds. Certain units may have a lower allowable weight and, thus, a different tip hose. The operation manual included with the unit will inform you of the specification if the unit requires a smaller than standard tip hose. It is the operator's duty to know the specification of the unit in operation (Figure 21). **Find out if your unit has special requirements!**

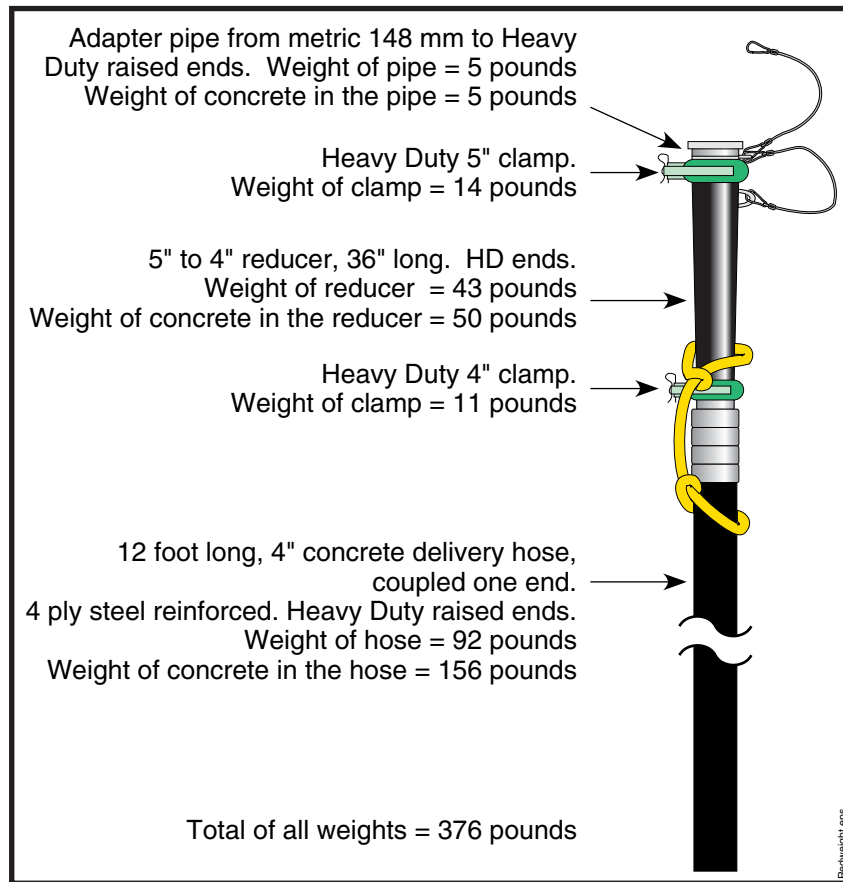

Figure 21
A typical reducer/hose combination

6.17

⚠ WARNING A *concrete delivery hose* is a flexible concrete hose that has two end couplings. An *end hose* is a flexible concrete hose that has one end coupling. In normal usage, it is preferable to have an end hose as the last piece of delivery system. If you will be swinging the full boom over workers or property you must be able to plug the delivery system. See the instructions for plugging the delivery hose on page 43.

6.18

⚠ WARNING All hanging system components must be fastened with safety cables or straps, and **each component must be capable of handling the maximum concrete pressure of the machine** (see Figure 22).

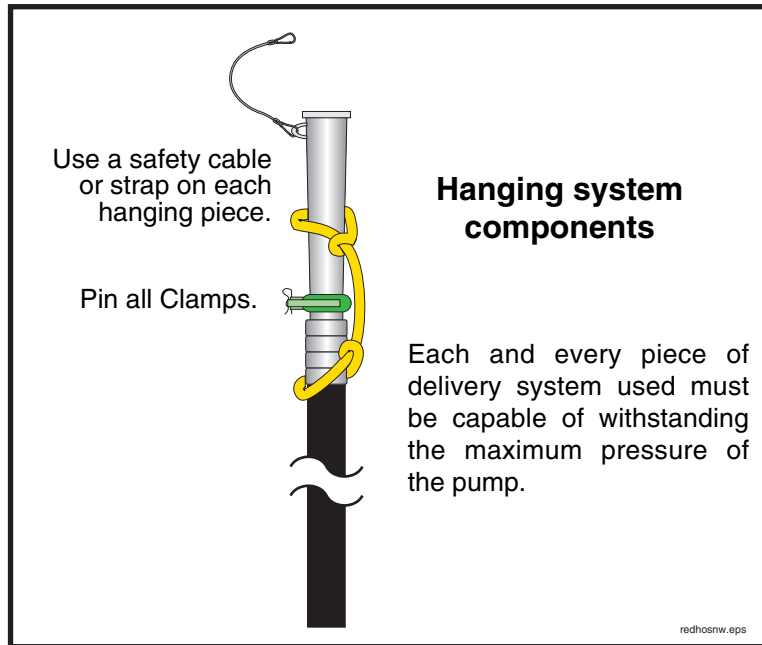

Figure 22
Assure the safety of hanging system components

6.19

⚠ WARNING Placing booms possess a very wide effective operating range. Due to this high degree of mobility, some placing booms can reach a position unsuitable for practical operation. Under certain circumstances **overloading, tipping, or damage to the boom is possible**. These unsuitable areas are documented on safety decals and in operation manuals (see Figure 23). **Be aware of these areas if they apply to your unit and set up the pump taking these areas into consideration.**

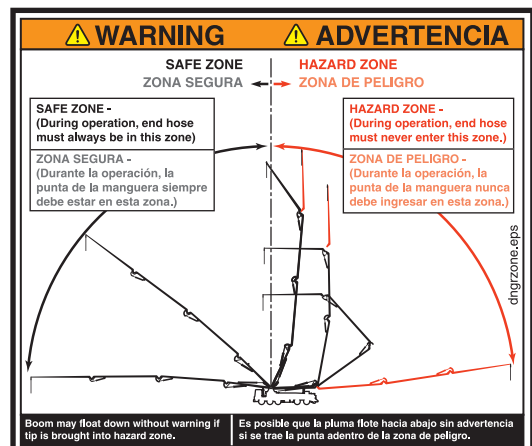

Figure 23
An example of a hazard area decal

SAFETY MANUAL

6.20 **⚠️ WARNING** Collision hazard! Secure the immediate area of the machine from public traffic in accordance with all applicable regulations (warning lights, safety cones, barricades with flashers, etc.).

6.21 **⚠️ WARNING** Consider the safe approach and departure of the ready-mix trucks and adjust your setup accordingly. Adjusting your setup position by a few degrees one way or another could mean the difference between a safe approach and an unsafe approach. Some examples of unsafe approaches are: too near an excavation or sticking out into traffic.

6.22 **⚠️ WARNING** If you set up the unit with one or more outriggers not fully extended on the side away from the pour (shortrigging), you will tip the machine if you forget and rotate the boom over the side with the unextended outriggers. That being said, it is known that under certain circumstances, shortrigging is unavoidable (see Figure 24). If no alternatives are practical and you must shortrig for a particular job, keep these points in mind.

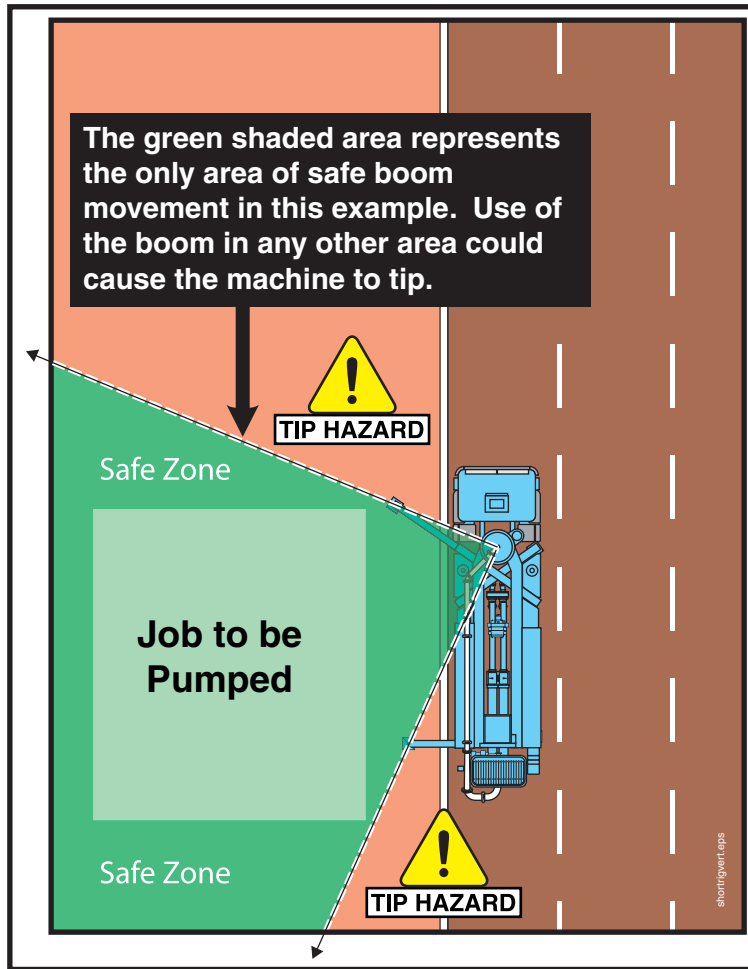
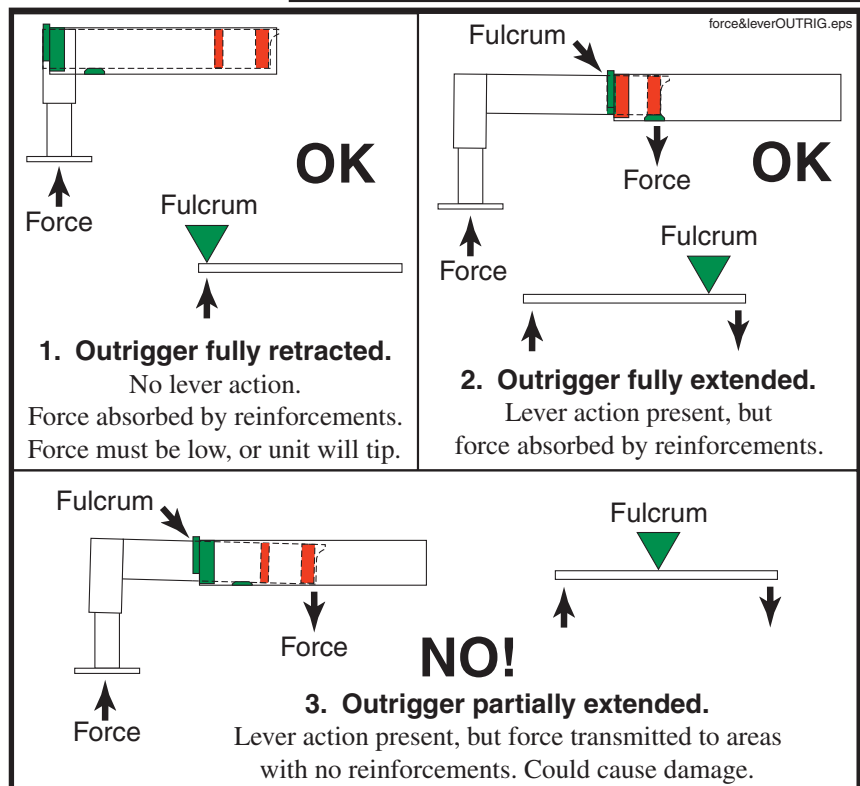
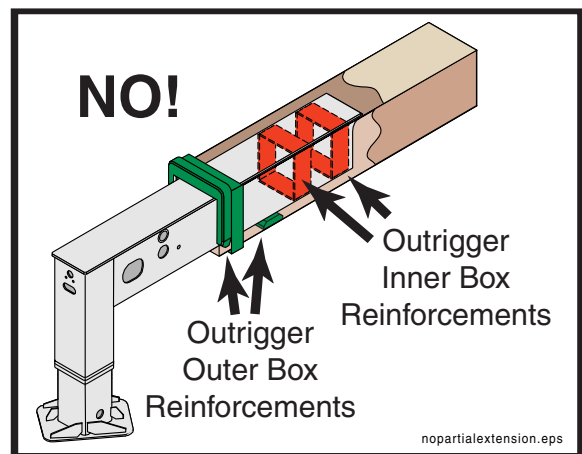

Figure 24
Shortrigging

- You may only operate the boom when it is placed between outriggers that are completely extended; you may tip if the boom is placed anywhere else.

- You should still jack the outriggers that are not fully extended. This will assist in stabilizing and preventing the unit from rocking. The margin of safety this gives you is very small; and won't prevent you from tipping.
- Don't get lazy! If it is possible to extend all of the outriggers, do it!
- Don't forget that you didn't fully extend all the outriggers. Explain to other workers on the job what will happen if you forget and slew the boom over unextended outriggers. That way, if they see you are moving the boom into a tipping area, they may be able to warn you.
- Outriggers that cannot be fully extended should NOT be partially extended unless specifically allowed by the manufacturer. The inner and outer outrigger box reinforcements will not align in intermediate positions. (Figure 25.)

Figure 25
Partial extension is not allowed



SAFETY MANUAL

⚠ WARNING When setting the outriggers, jack the unit to within 3° of level, or according to the operation manual of your unit. If the unit is not set up within the specification for level, the boom brakes could fail, causing the boom to rotate downhill by the force of gravity.

6.23 **⚠ WARNING** Tipping hazard! Do not unfold the boom until the outriggers have been correctly positioned and secured! The outriggers must be completely extended and opened as described in the operation manual. Do not partially extend the outriggers because intermediate positions are **not safe!** See the information regarding shorttrigging (paragraph 6.22).

6.24 **⚠ WARNING** Tipping hazard! Check soil conditions before jacking the outriggers. If necessary, use cribbing or suitable pads under the outrigger legs to increase the area of soil contact. See the chart in Figure 26 for examples of load bearing capacities of various soil types and for an example of how to calculate how much cribbing is needed. If in doubt, the site management may be able to supply the load bearing capacity of the soil.

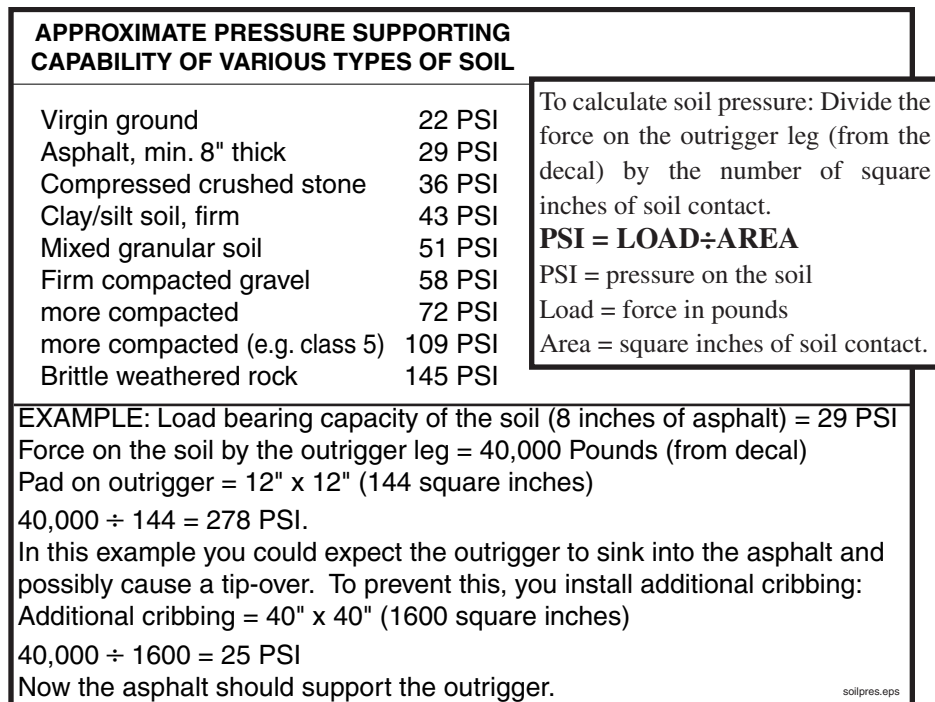

Figure 26
Calculating load bearing capacity

6.25 **⚠ WARNING** Tipping hazard! Regardless of whether you know the load bearing capacity of the soil or not, you must test your setup by slowly moving the empty boom over each outrigger (Figure 27). If the outrigger begins to sink, retract the boom or move it back in the direction from which it came, until the weight of the boom is removed from the outrigger. Add more cribbing under the outrigger pads and retest until the outriggers are stable. When you put concrete in the boom, again check the outriggers for sinking. Continue to add more cribbing until the soil can support the load. After the pour begins, continue to check the outriggers for sinking throughout the course of the day. The stability of the unit **must** be ensured.

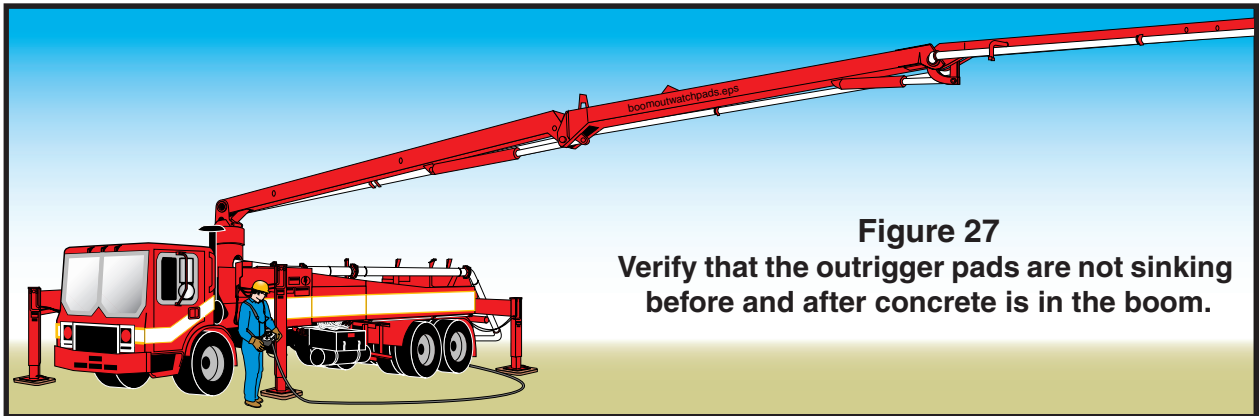

Figure 27
Verify that the outrigger pads are not sinking before and after concrete is in the boom.

6.26

⚠ WARNING **TIPPING HAZARD!** Maintain a safe distance between the unit and the edge of a cliff or any excavation. The rule of thumb is: for every foot of drop, stay back from the base edge at least 1 foot (the one to one rule). (See Figure 28.) Note that the forces on the outriggers are transferred to the soil at a 45° angle. Watch out for the condition shown in Figure 29.

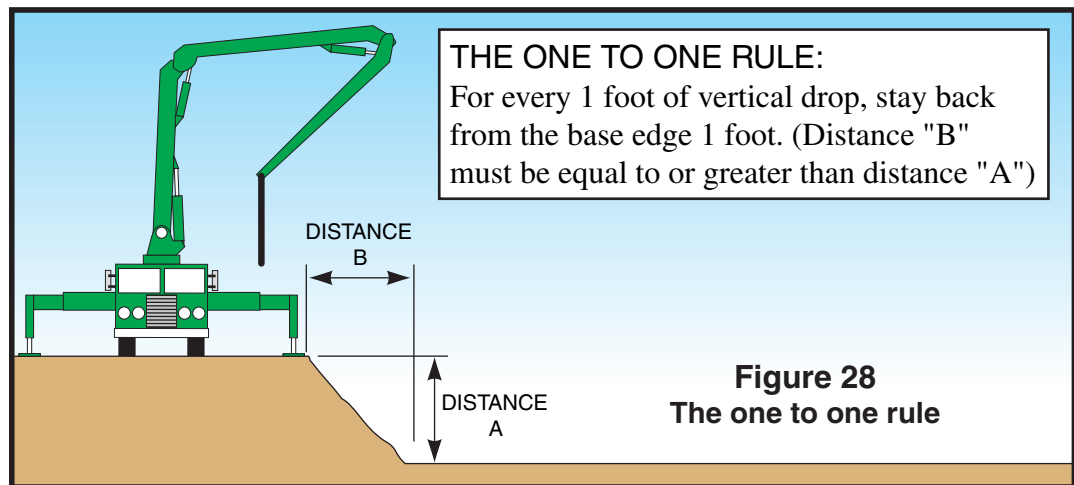

Figure 28
The one to one rule

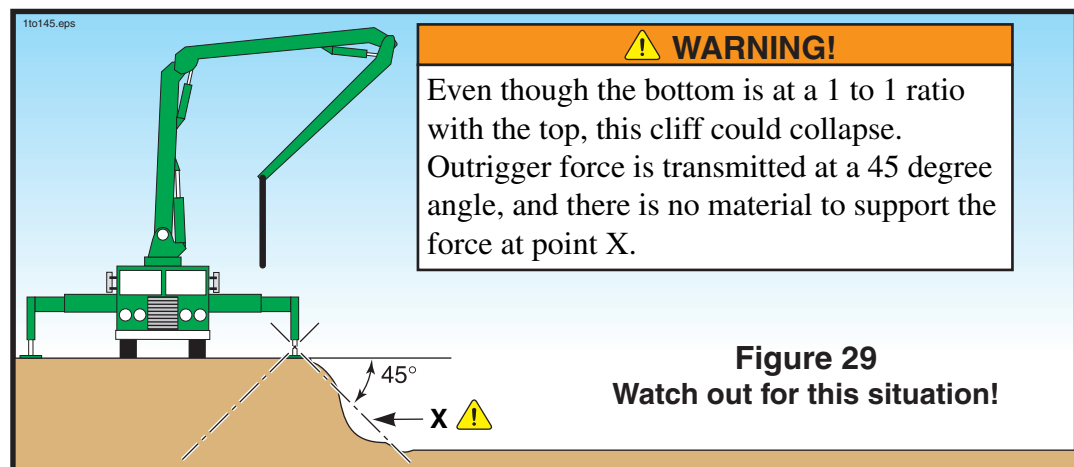

Figure 29
Watch out for this situation!

SAFETY MANUAL

6.27

⚠ WARNING Tipping hazard! Take care when setting the outriggers (Figure 30). Never set up on uneven or hilly soil or try to bridge a hole with cribbing. In these cases, you could dig a flat spot in the soil (A, B, & C). Be sure that the outrigger pad contacts all pieces of cribbing. Run cribbing in the opposite direction, if needed (D).

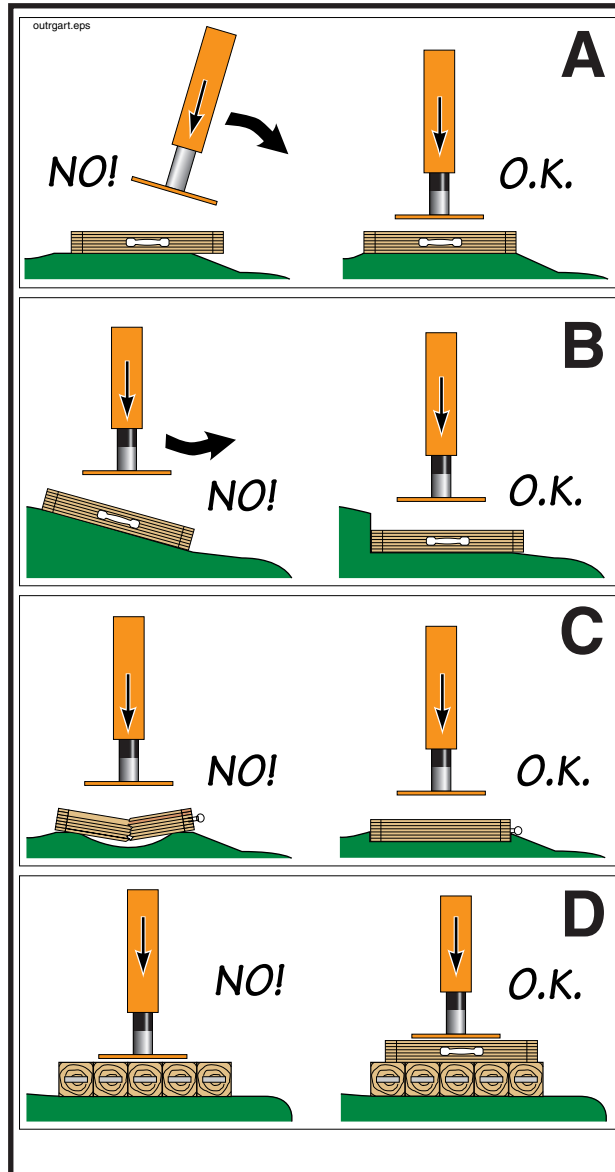

Figure 30
Beware of these outrigger hazards

6.28

⚠ WARNING When you have the outriggers positioned correctly, close all outrigger hydraulic shutoff valves (if your machine is so equipped).

- 6.29 **⚠ WARNING** Do not unfold or operate the placing boom when lightning is present in the immediate area. If you are operating and lightning moves into the area, put the boom into the transport position, or another low position, and seek shelter until the lightning is gone.
- 6.30 **⚠ WARNING** Tipping hazard! Do not operate the placing boom when wind velocity exceeds 48 m.p.h. (77 k.p.h.)! When wind velocity exceeds 48 m.p.h. the machine could tip, and the boom may not be able to slew into or resist slewing away from the wind.
- 6.31 **⚠ WARNING** If you will be unable to see the point of placement, establish a system of communications with the workmen who will be there. Arrange for radio communications, a system of visual or auditory signals (lights or bells), or a spotter. If a spotter is used, **agree on hand signals before beginning the pour!** If the boom will be moved extensively, arrange for a workman to stay with the pump and to put yourself in a position to see the end of the boom (Figure 31).

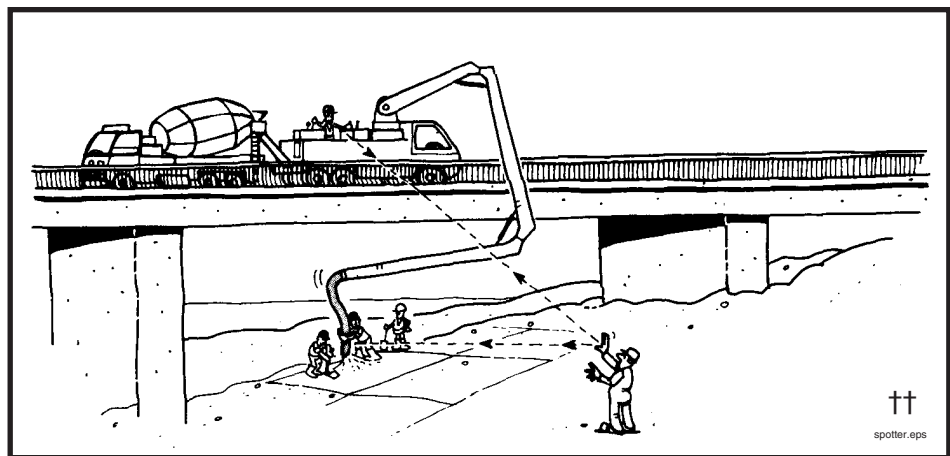

Figure 31
Arrange communications before starting

- 6.32 **⚠ WARNING** Possible boom damage! If you will be pumping out of the boom into a separately laid pipeline, you must use a flexible hose to connect them. Do not connect steel pipe directly to the boom. **Be sure that the hose is capable of handling the maximum concrete pressure of the pump.** Do not let the end of the boom rest on the ground when connected to a separately laid pipeline.

SAFETY MANUAL

6.33

⚠ WARNING It is extremely important to verify that the material delivery system of the boom is capable of handling the pressure of the concrete pump. In some cases, you may not be able to use the boom if you are pumping on piston side. It is up to the machine owner and operator to determine if the boom can be used when pumping on piston side. Keep in mind that pipeline wears out with each stroke of the pump. Verify pipe wall thickness and compare it to pressure handling capabilities of that pipe style. The chart for this comparison is found in the appendix of this manual.

6.34

⚠ WARNING Use only material delivery system components in good condition. The useful life of delivery system components is affected by pumping pressure, concrete composition, pipeline material, velocity of moving concrete, and other factors. The use of ultrasonic equipment for determining pipe wall thickness is highly recommended (Figure 32). Read and understand the minimum wall thickness chart in the appendix section of this manual. If you don't understand the chart, contact the service department of the manufacturer of your machine; they will assist you.

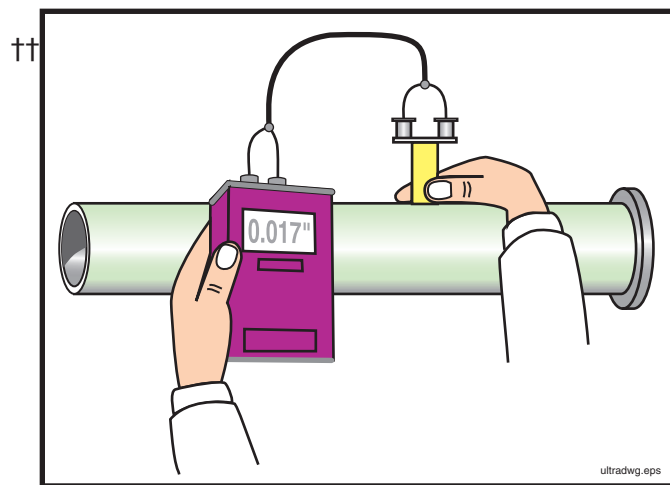

Figure 32
Check for wear on the delivery system components

6.35

⚠ WARNING When the machine is ready to work, secure it against unauthorized use! Either stay with the unit or make sure no one can start it without you. This could be accomplished, for example, by activating the emergency stop switch of the remote control box (cable or radio, whichever is active), then locking it in the cab of the truck. Another way would be to take the transmission out of gear, lock the cab of the truck, and take the key with you.

6.36

⚠ WARNING Watch for children! When the machine outriggers are jacked up, it is very easy for children to access the space underneath the machine. The rotating driveline(s) and hot components pose serious hazards. Do not let anyone remain under the machine while it is running.

- 6.37 **⚠ WARNING** If spectators will be near the pour, cordon off an area where they will be safe. Never operate the machine if it is not safe to do so, even if the spectators just want to see a certain operation or function.

7. Setting Up A Trailer Mounted Pump and/or A Separate Pipeline

- 7.1 **The job setup phase sets the stage for most accidents.** Taking a few extra moments to correctly set up the job will improve your chances of having a safe, trouble free day.
- 7.2 **The operator is responsible for the safe operation of the machine.** Notify your employer, the job superintendent, and/or O.S.H.A. if you are being asked to set up in an unsafe manner. **You are never required to take a chance with safety.** You are the **only** person who can determine that the job circumstances under your control are safe.
- 7.3 **⚠ WARNING** The **power connections for electrically driven concrete pumps or separate placing booms must be made by a licensed electrician.** The supply power and appropriate disconnect boxes are the responsibility of the contractor.
- 7.4 **⚠ WARNING** Electrical power on the job site may be taken only from a **fused, grounded disconnect box with a disconnect switch that can be locked against activation.** If you will be making repairs to the concrete pump or separate placing boom, first lock out the power at the disconnect box.
- 7.5 **⚠ WARNING** On units equipped with electric motors, **check the power cables every day.** If they are frayed or have open spots in the insulation, replace the wire. If the connectors are worn or loose, have repairs made by a licensed electrician.
- 7.6 **⚠ WARNING** Consider the **safe approach and departure of the ready-mix trucks and adjust your setup accordingly.** Adjusting your setup position by a few degrees one way or another could mean the difference between a safe approach and an unsafe approach. Some examples of unsafe approaches are: too near an excavation or sticking out into traffic.
- 7.7 **⚠ WARNING** **Avoid collisions!** Secure the immediate area of the machine from public traffic in accordance with all applicable regulations (warning lights, safety cones, barricades with flashers, etc.).
- 7.8 **⚠ WARNING** Pipelines, end hoses, couplings, and all other **material delivery components must be able to withstand the maximum concrete pressure of the pump.** Be sure of it! Read and understand the minimum wall thickness chart found in the appendix of this manual.
- 7.9 **⚠ WARNING** Do not use a piece of pipeline, end hose, coupling, or any other material delivery component that is not in good condition. **Replace, do not repair damaged pipes and hoses.** Concrete pipeline system is subject to wear, and the rate of wear is affected by pumping pressure, concrete composition, pipeline

SAFETY MANUAL

material, and other factors. Read and understand the minimum wall thickness chart in the appendix of this manual. **Bursting pipes and concrete escaping under pressure is a serious safety hazard!** (See Figure 33.)

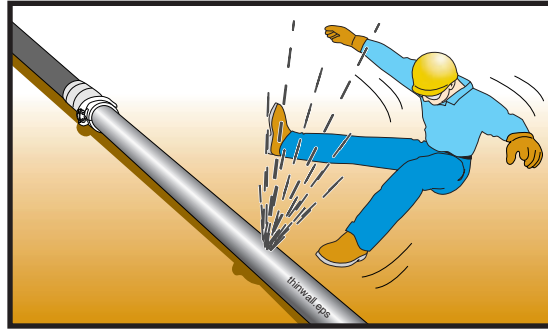

Figure 33
Delivery system components must be able to withstand maximum pump pressure

- 7.10** When laying out a pipeline, it is preferable to use an elbow instead of a hose to make direction changes. Elbows have less resistance to flow than hoses, and will therefore reduce the overall pressure required to push the concrete.
- 7.11** Always use the largest diameter pipeline that is practical, and use steel pipe instead of rubber hose. This will keep the pressure required to push the concrete to a minimum.
- 7.12** Support the delivery pipeline. Either an “S” transition pipe should be used to bring the pipe to ground level, or **each** section of the pipeline should be supported at the pump outlet level.
- 7.13** **⚠ WARNING** The sections of pipe nearest the pump are subjected to the highest pressure and the greatest wear. Because of this increase of pressure near the pump, you should install only thick walled pipe, in “like new” condition there. Read and understand the minimum wall thickness chart in the appendix of this manual.
- 7.14** **⚠ WARNING** **The maximum concrete pressure of the pump must be the only factor used to determine what thickness of pipe and what type of ends are needed.** In the case of a rock jam or any other type of blockage, **the maximum pressure of the pump will be exerted.**
- 7.15** Grooved (Victaulic) ends are **not recommended** for concrete pumping. Read and understand the comparison between heavy duty raised, metric, and grooved ends in the appendix of this manual.
- 7.16** **⚠ WARNING** If the pipeline remains on the job (as is the case when pumping a high rise building), **the operator is responsible for checking the pipeline for dents, cracks, wear, and continuity each day before the pour begins.**

7.17

⚠ WARNING In vertical runs, the weight of the vertical sections of pipe must be supported by a thrust block (often called a *deadman*, Figure 34) or other load-bearing device. **Each section of pipeline in a vertical run must be secured from lateral and horizontal movement.**

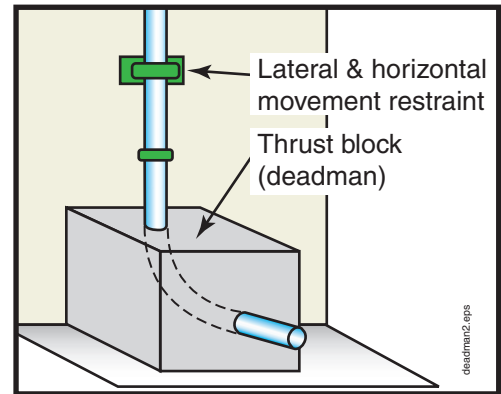

Figure 34
A thrust block (deadman)

7.18

⚠ WARNING If you will be unable to see the point of placement, establish a system of communications with the workmen who will be there. Arrange for radio communications, a system of visual or auditory signals (lights or bells), or a spotter (Figure 35). If a spotter is used, **agree on hand signals before beginning the pour!**

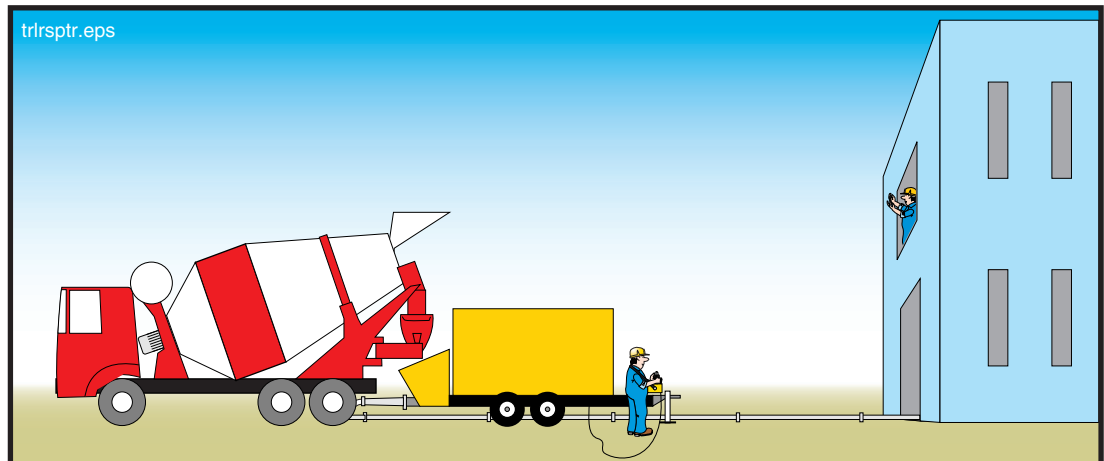

Figure 35
Arrange communications before starting

7.19

⚠ WARNING Never leave the machine unattended when it is running or ready to run. Stop the engine and remove the key if you must leave the area. Make sure no one can start the machine without you. If you're unsure that the engine would restart, you must leave someone to monitor the unit. This is especially critical if there are children in the vicinity.

SAFETY MANUAL

- 7.20 **⚠ WARNING** Watch for children! It is easy for children to access the space underneath the machine, but it is not safe for them to do so.
- 7.21 **⚠ WARNING** If spectators will be near the job, cordon off an area where they will be safe.
- 7.22 **⚠ WARNING** If you will be cleaning the pipeline with compressed air at the completion of the job, **be sure that you have all the necessary accessories to do the job safely.** If you don't have all of them, make arrangements to get them before you begin to pump. **Do not improvise on this. Make sure** that you have the right parts. The minimum accessories include:
- A blow out head with properly sized air discharge regulator valve, and separate water/air inlet. The two openings should be spaced apart far enough that a blowout ball could not cover both openings at once.
 - A *go devil*, or a hard sponge ball. Regardless of which is used, it **must** fit into the pipeline tight enough that air cannot escape ahead of it.
 - A ball or “go devil” catcher that will catch the go devil or ball, or some other method of controlling the discharge while the line is being purged of material. There are two types of catchers (see paragraph 7.23).
 - A hose that is rated for the pressure of the air compressor you will use and that is able to connect with both the air compressor and the blow out head. The hose must be in good working condition and must be free of cracks, frays, tears or other damage.
 - If you will be cleaning the pipeline with compressed air at the completion of the job, be sure an adequate air compressor is available before starting the job.
 - If you will be cleaning a vertical pipeline with compressed air at the completion of the job, you **must have a shutoff valve or switching valve installed at the bottom of the vertical run!**

Figure 36
Ball catcher and
blow out head

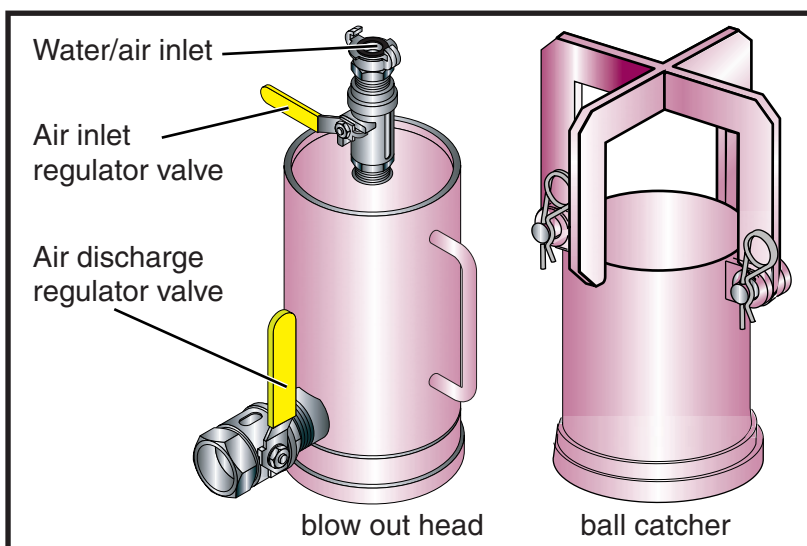

7.23

⚠ WARNING There are two types of ball catchers. Know which type of catcher you are using. You may need to adjust your clean out procedure according to which type you have. The two types are as follows.

1. Catchers that stop the ball or go devil before air can escape, and
2. Catchers that allow the air out of the pipeline after the ball or go devil has reached the end.

Each type has advantages and disadvantages (Figure 37).

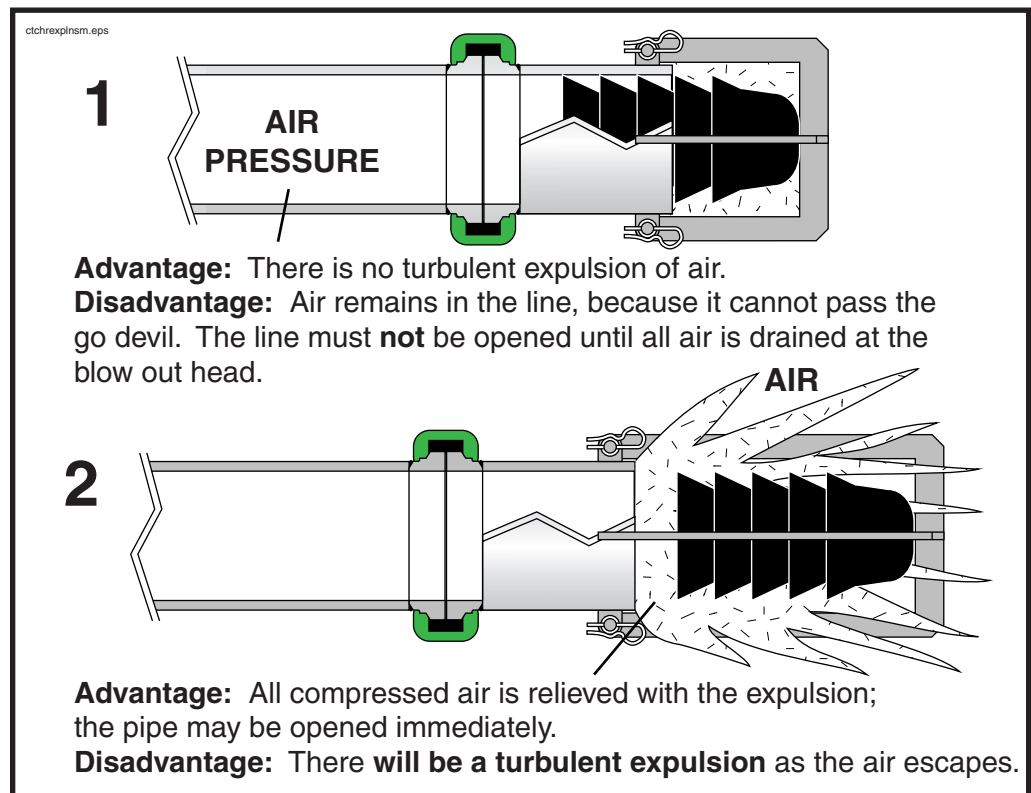

Figure 37
Types of catchers

With catcher type 1, the go devil stops, but air is still trapped behind it. The advantage is prevention of the sometimes violent expulsion of air at the end of the pipe. The disadvantage is that the air must be drained from the blow out head before the pipe line is safe to open. The pipeline must be controlled; allow no one to open it until all compressed air is relieved.

Catcher type 2 is long enough that the compressed air escapes behind the go devil. **Note!** This would happen with either catcher when used with a ball instead of a go devil. The advantage of this is that once you hear the turbulent expulsion, there is no pressurized air remaining in the line, and the line may be opened immediately. The disadvantage is the expulsion itself. In this case, the end of the line must be controlled because flying concrete and aggregate pose a hazard.

Both catchers can be safely used if care is given to the hazards involved.

III. Concrete Pump Operation

8. Safety Rules For Pump Operators

8.1 **⚠️ WARNING** Only qualified operators are allowed to operate the pump. A “Qualified Operator” is defined as someone who:

- has reached the age of 18 years (21 for interstate travel),
- is physically and mentally capable,
- has been trained in the operation and maintenance of the pump and the placing boom (if applicable),
- has demonstrated his/her capabilities to the employer in respect to the operation and maintenance of the pump and placing boom, and
- can be expected to perform these duties, as assigned, in a reliable manner.

8.2 **⚠️ WARNING** Because the operator is responsible for the safe operation of the machine, it is crucial that he/she understands the proper operation of the machine and the safety rules that apply to the job at hand, so the course of action taken in unforeseen circumstances will be a safe one. Only thorough training and supervised job experience can supply the necessary understanding.

8.3 **⚠️ WARNING** When operating the machine, wear **Personal Protective Equipment**. (See Figure 38.)

* Needed when exposed to airborne cement particles (or any other toxic dust).



Figure 38
Wear Personal Protective Equipment (P.P.E.)

8.4 **⚠️ WARNING** All guards, covers, and service flaps must be closed and locked during operation.

8.5 **⚠ WARNING** **Electrocution hazard!** If you are operating and lightning moves into the area, put the boom into the transport position, or another low position, and seek shelter until the lightning is gone.

8.6 **⚠ WARNING** **Crushing hazard! Never, ever** position yourself between a ready mix truck and the pump! Stand off to the side, so the ready mix driver can see you at all times (Figure 39).

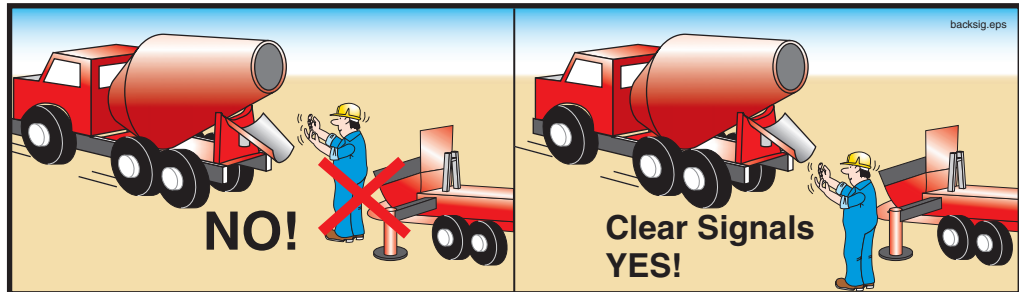

Figure 39
Never stand between the ready mix truck and the pump
Use clear and concise hand signals

8.7 **⚠ WARNING** When backing in ready mix trucks, use clear and concise hand signals (Figure 39).

8.8 **⚠ DANGER** You must avoid hazardous proximity or contact with power lines under all circumstances. **Be sure** that you maintain 17 ft. (5 meter) clearance! The 17 foot clearance allows room for the movement of the wires and the boom by wind force, electrical arcing, and human error (Figure 40). **Do not take chances with high voltage; it is the number one killer of concrete pump operators!**

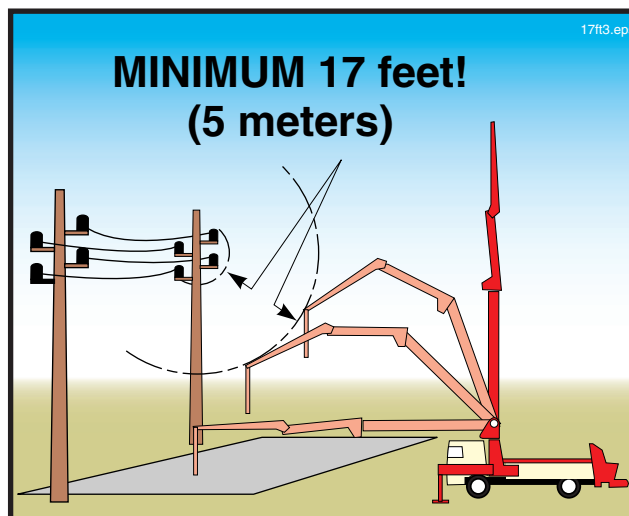

Figure 40
Maintain a clearance of at least 17 feet from wires

SAFETY MANUAL

8.9 **⚠ DANGER** When overhead wires are in the area that the boom will be moving to complete a pour, a spotter must be employed whose only job is to warn the operator if the boom comes within 17 feet of the wires. The spotter must understand the responsibilities assigned, and must be able to judge a 17 foot distance.

8.10 **⚠ DANGER** Direct contact with a live power line is always dangerous to everyone and anyone electrically connected to the machine (Figure 41). Use **extreme caution** near high voltage wires.

Figure 41
If the pump is energized, everything that touches the pump is also energized

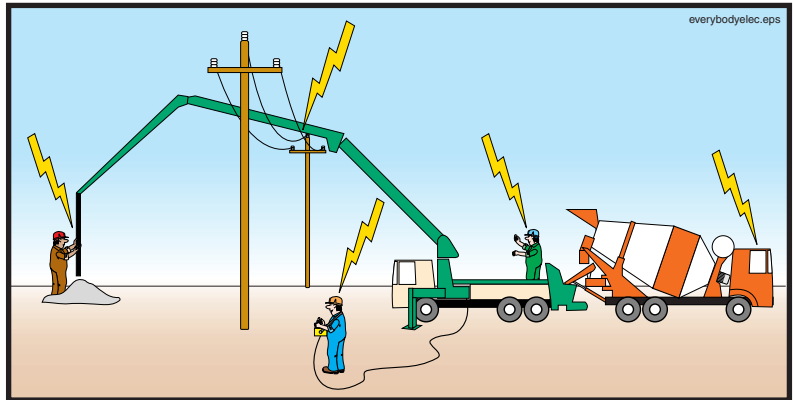

8.11 **⚠ DANGER** Do not rely on depth perception when working near high voltage lines. Put yourself at the best possible vantage point to see the distance between the boom and the wires. If that is not possible, then **you must use a spotter!** (See Figure 42.) See the definition of “spotter” in the glossary found in the appendix of this manual.

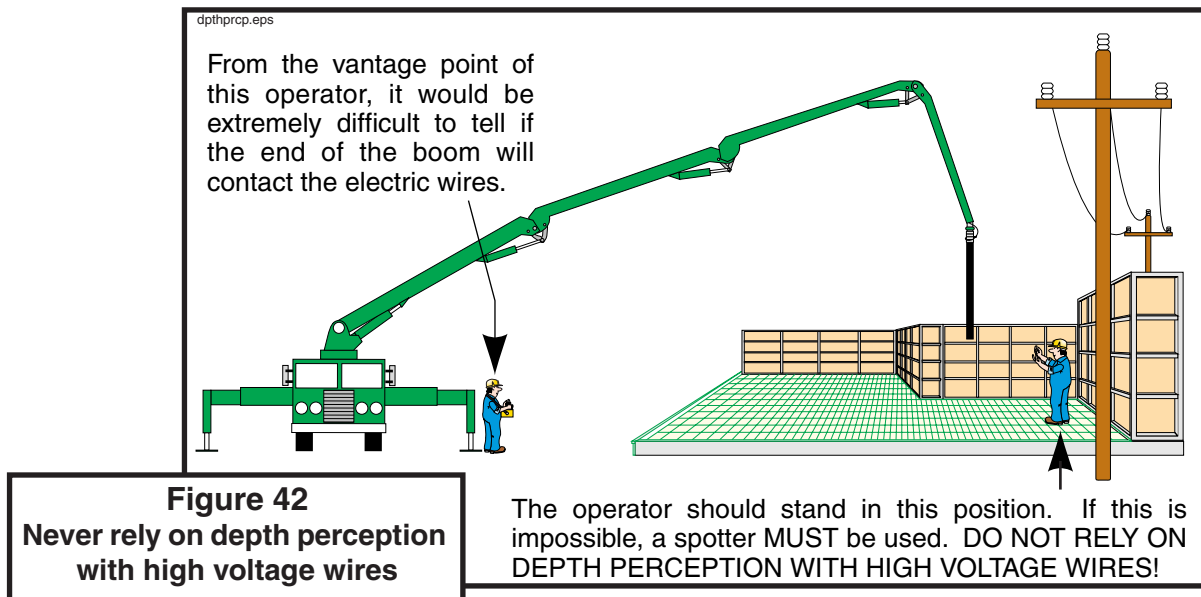

8.12

⚠ DANGER Watch for wires that are not directly in the area of the pour. Accidents can happen when moving between points of placement, or when moving the boom after the pour is completed (Figure 43). **Never let down your guard when the boom is in the air!**

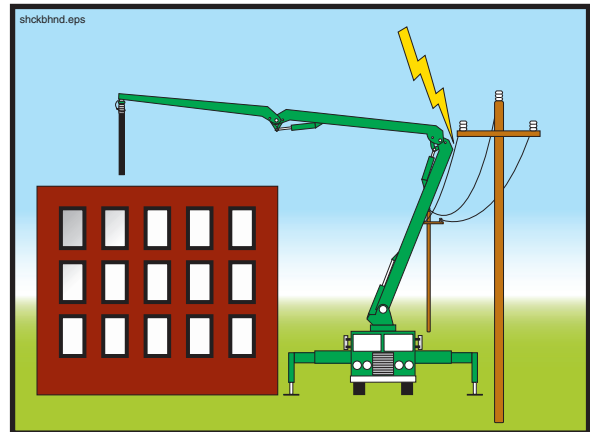
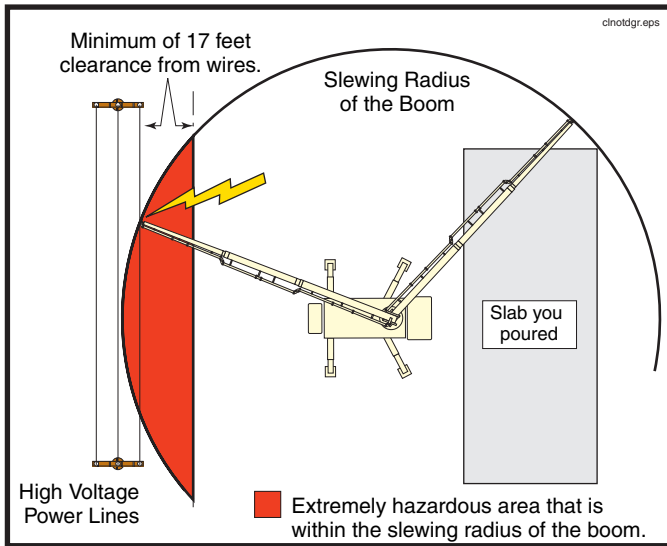

Figure 43
Never let down your guard when moving the boom

8.13

⚠ DANGER High voltage makes conductors out of materials that would normally not conduct! Many nonconductors will conduct enough current to kill you if you contact the 8000 volts to ground that is normally found on power poles in the United States (Figure 44). Voltage in the wires may be higher than 8000, especially in industrial areas.

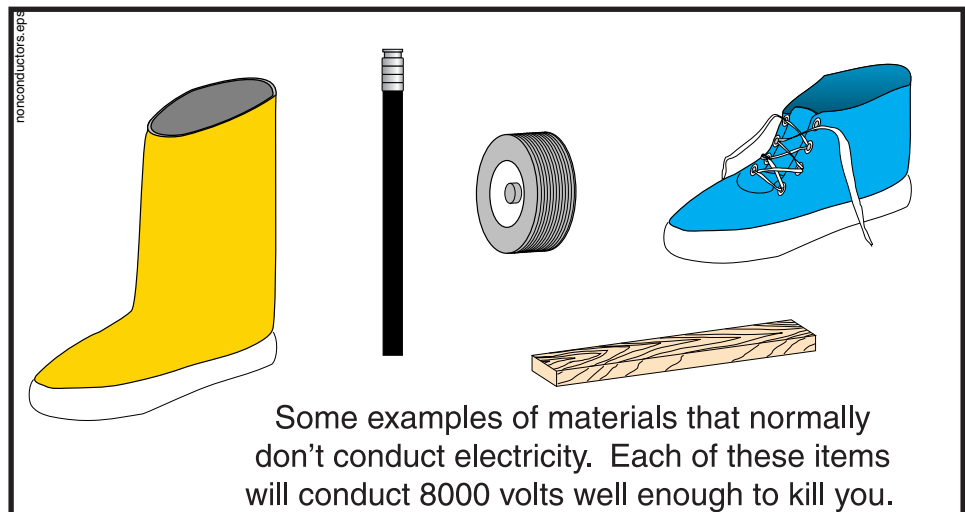

Figure 44
Even poor conductors will conduct high voltage

SAFETY MANUAL

8.14

⚠ CAUTION **Loss of hearing!** While standing near a working concrete pump, sound pressure levels may exceed O.S.H.A. standards for constant exposure (Figure 45).

PERMISSIBLE NOISE EXPOSURES*
 *Under part 1910.95 “Occupational Noise Exposure,” (Dept. of Labor) of the Code of Federal Regulations, Chap. XVII of Title 29 (39 F.R. 7006).

DURATION per DAY in HOURS	Sound level in dB (A) Slow response
8	90
6	92
4	95
3	97
2	100
1 1/2	102
1	105
1/2	110
1/4 or LESS	115



††

WEAR HEARING PROTECTION!

Figure 45
Noise level and exposure time limits

8.15

⚠ WARNING Do not allow unauthorized persons in the operational area of the pump and boom. Warn unauthorized persons present in the area to leave and stop work if they do not comply.

8.16

⚠ WARNING Do not use the boom as a hoist or crane! (Figure 46.)

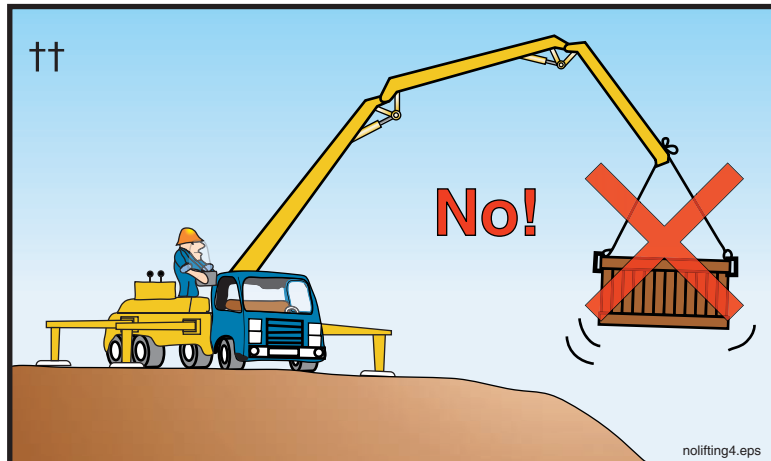

Figure 46
No lifting with the boom

8.17

⚠ WARNING **Explosion hazard.** Never remove the fuel cap or refuel the unit near hot surfaces, sparks, or open flames. Never smoke while refueling.

8.18

⚠ WARNING Do not let the concrete level in the hopper become low! If air is sucked into the material cylinders, the pump will compress the air. Compressed air always poses a hazard as it is expelled from the hopper or the delivery pipeline (Figure 47). If air is taken into the material cylinders, take the following steps to minimize the hazard:

1. Stop the pump immediately. Hit the emergency stop button if that is the quickest way to stop the pump. There will be an expulsion of compressed air the next time the concrete valve shifts, which can be safely absorbed by filling the hopper with concrete.
2. Pump slowly in reverse for a couple of strokes. This will not remove all the air, but it should minimize the amount left in the pipeline.
3. Persons standing at the discharge end or near the delivery line must be warned to move away until all of the air has been purged. Personnel should move a prudent and reasonable distance beyond the end-hose movement area or the point of discharge, and personal protective equipment (PPE) should be worn (Figure 47).
4. When the pump is restarted, the slowest possible speed should be used until **all** air is removed from the pipeline. Don't assume that the first little air bubble is the end of the compressed air.
5. Do not allow anyone near the discharge until concrete runs steadily from the end and there is no movement of the delivery system.

If workers are positioned in high or precarious places, warn them to expect a loud sound as the air escapes the pipeline. (Warn them even if they are well away from the discharge.) That way, we can prevent the worker from falling as a result of being startled by the noise.



Figure 47
Remove everyone from the discharge
area whenever air is in the line

SAFETY MANUAL

8.19

⚠ WARNING When initially priming the delivery system, when restarting after moving, when restarting after adding or removing hoses, when attempting to remove a blockage by “rocking” the concrete, or whenever air has been introduced into the line, warn everyone to stay away from the discharge until material runs steadily. Personnel should move a prudent and reasonable distance beyond the end-hose movement area or the point of discharge, and personal protective equipment (PPE) should be worn (Figure 47).

8.20

⚠ WARNING A bulk density of approximately 150 pounds per cubic foot is assumed for the material to be pumped with a placing boom (normal concrete). If you intend to pump material with a higher bulk density (e.g., steel fiber entrained concrete), you must contact the manufacturer for advice. Failure to do so may result in damage to the boom and/or instability in certain operating positions.

8.21

⚠ WARNING **Blockages in the pump or delivery pipeline can create an unsafe condition.** Blockages are caused by many different factors, as outlined below.

CAUSES OF
BLOCKAGES

- **Faulty concrete mix design.** The concrete that is being supplied may not be a pumpable mix, for example there may be too much sand or too little cement. There may be bleeding or segregation. Some admixtures adversely affect pumpability (e.g., too much air entrainment). If the mix is not pumpable, no amount of operator expertise will make it so.
- **The line size may be inadequate.** The line size should always be at least 4 times larger than the largest aggregate being pumped, or blockages could occur.
- **Worn concrete valve parts.** Worn parts allow the finest material and water to escape back into the hopper when pressure is applied.
- **Pipeline and joint deficiencies.** This would include dirty pipes (pipes that have not been cleaned properly), worn and leaking pipe joints that allow loss of concrete fines and water, pipes that haven’t been properly primed before starting, and too many sections of rubber hose, which increases friction. These are all causes of blockages that can be controlled by the operator.
- **Pump inadequate for the application.** The pump selected for the job may not have enough pressure or horsepower available for the required duty.
- **Concrete setting up in the pipeline.** This may be caused by delays on site (e.g., repairing a broken form), or by attempting to pump “old” concrete (concrete that was batched hours before pumping and is being kept alive only by adding water and constant agitation). Weather conditions can also affect how quickly the concrete becomes hard. Companies should establish procedures for these situations. A good rule of thumb is: **If in doubt...wash out.**
- **Foreign matter in the concrete.** Pieces of old concrete that break away from mixer fins, unmixed clumps of cement, mixer fins, hammers, and furry mammals are examples of foreign matter that have caused blockages.
- **An inexperienced operator can cause blockages by setting up the job improperly.** For example, if the placing crew is forced to add hose or pipe to reach a far point after the pour is already in progress, there is a great chance of creating a blockage due to the dry conditions inside the pipe or hose. It is for this reason that the job should be set up so pipe or hose need only be removed (never

added) as the day progresses. If dry pipe or hose must be added, it must be lubricated just like the rest of the pipe was lubricated when you first started.

- **An inexperienced placing crew can cause blockages by kinking the end hose.** This type of blockage can lead to serious accidents because the hose may un-kink by the force of the pump.
- **The concrete becomes segregated in the hopper.** When it's raining hard, the cement and fine material get washed from the stone and coarse sand. This mix will not pump. **Cover the hopper** as you wait out the passing storm. It is also for this reason that you should **never allow a truck mixer to wash out in your hopper!**

8.22 **⚠ WARNING** Never try to remove a pipeline blockage by applying high pressure to it, because that will cause the blockage to become a plug. If you have a blockage, immediately stop the pump. Stroke the pump a couple of times in reverse. Slowly stroke the pump in forward, and try to dislodge the blockage. If you are moving the blockage, continue to do so slowly and gently. While attempting to clear the blockage, remove all personnel from the discharge area, as air may be introduced into the placing line during this process.

8.23 **⚠ WARNING** If the pump or associated equipment develops a problem that creates an unsafe condition, you must stop pumping immediately! Do not restart until the unsafe condition has been remedied.

8.24 **⚠ WARNING** The following points must be observed when locating a blockage.

- Pump in **reverse** for **at least two strokes**, then stop the pump. **Do not allow anyone to open the pipeline** until this is done (Figure 48).
- Wear personal protective equipment when opening a blocked pipeline.
- Clear the area of nonessential personnel before opening the line.
- Plugs will be found in (in the order of likelihood) reducers, hoses, elbows, and pipe.
- If you are tapping the pipe to find the plug, the sound will be a dull thud (tik-tik) rather than a ringing sound (tong-tong) at the spot of the plug, because the jammed material will keep the pipeline from vibrating. (This method won't find a plug in a hose.)

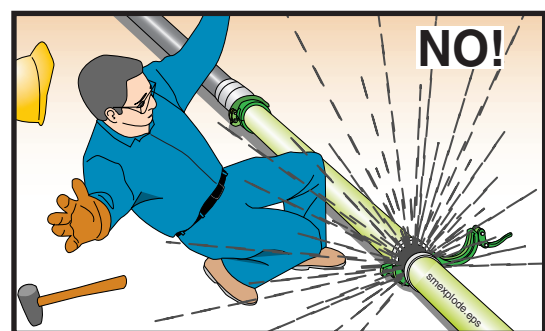

Figure 48
Never open a pressurized pipeline

SAFETY MANUAL

8.25 **⚠ WARNING** It is possible that some pressure will remain in the pipeline after reversing the pump. Use a shovel or pry bar to open the clamps on a blocked pipeline. Wear face protection, and turn away from the pipeline when opening the clamp.

8.26 **⚠ WARNING** It would be better to let the pipe be ruined by setting concrete than to risk injury by ignoring safe procedures. Always use safe practices when cleaning pipe. Remember, pipeline is replaceable, you are not.

8.27 **⚠ WARNING** **Do not kink hoses.** Kinking will cause the pump to create maximum concrete pressure. **The pump may unkink the hose with force!** (See Figure 49.)



Figure 49
Kinking the hose creates a hazard

8.28 **⚠ WARNING** Never use compressed air to clear a blockage! It is unsafe and unnecessary. The pump can develop much more pressure than an air compressor. If the pump pressure can't move it, air pressure won't either.

8.29 **⚠ WARNING** Never stand on, sit on, or straddle a pipeline while it's in use, or whenever it is pressurized. Pipeline wears out with each stroke of the pump. If the pipe bursts, you want to be to the side of it, not on top of it (Figure 50).



Figure 50
Never straddle or sit on a pressurized pipeline

8.30

⚠ WARNING Crushing/amputation hazard. Do not remove the water box covers or grates when the machine is stroking (Figure 51). If you must remove the water box cover (to add water, for example), and there is not a bolt-down grate over the water box, then stop the pump, take the transmission out of gear, and lock the cab so the pump cannot be restarted until you are finished and the covers are back in place. If a bolt-down grate is installed, you may simply stop the pump from stroking before removing the water box covers. Replace the covers before restarting the pump.

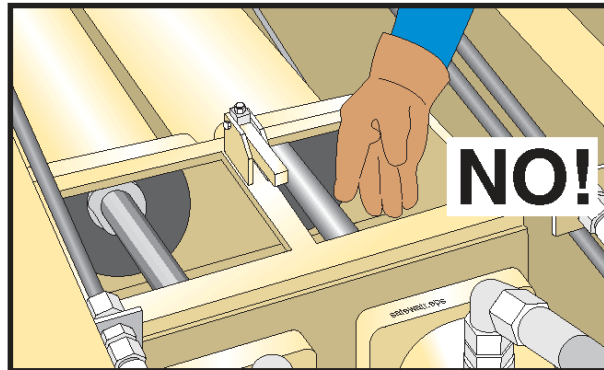

Figure 51
Keep your body out of the waterbox

8.31

⚠ WARNING Never leave the pump unattended! Before you leave a laborer, ready mix driver, or any other worker alone with the pump for any reason, make sure the worker who you leave with the pump knows:

- the safety rules for a person stationed at the pump (the rules are listed in this Safety Manual, beginning on page 57)
- how to stop the pump
- the location of the emergency stop switches
- how to signal you.

8.32

⚠ WARNING To prevent any unintentional movements of the machine, all control devices on the operator's panel and the remote control box must be switched off before changing from remote control to local control, or vice-versa. Whenever you are connecting or disconnecting the remote cable, push in the emergency stop button.

8.33

⚠ WARNING Crushing/amputation hazard. Never put your hands, feet, or any other body part into the water box, concrete valve, or hopper when the hydraulic system is operational or ready to operate! (See Figure 52.)

SAFETY MANUAL

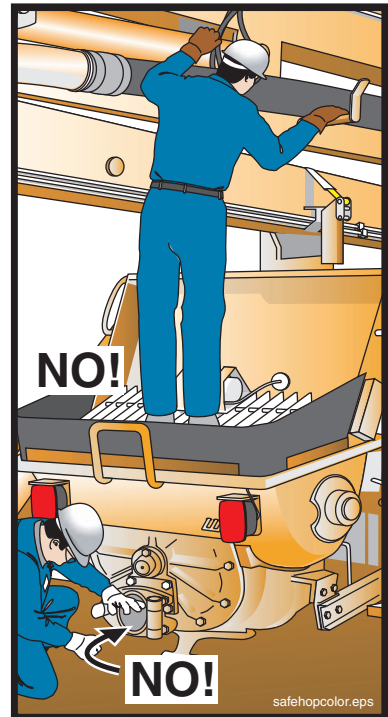

Figure 52
Don't put your body
in the machine

8.34

⚠ WARNING Do not work on the hopper, water box, concrete valve, or the hydraulic system unless the drive engine is turned off and the accumulator pressure (if so equipped) has been released! On units with internal combustion engines, the key must be removed. If there is more than one key, you should tag the ignition. On units driven by electric motors, the main disconnect must be locked out according to applicable standards.

8.35

⚠ WARNING Never operate the boom “blind.” If you can't see the point of placement, you must establish a system of communications with the workmen who can see the point of placement. Arrange for radio communications, a system of visual or auditory signals (lights or bells), or a spotter. If a spotter is used, **agree on hand signals before beginning the pour!** (Use of the ACPA standardized hand signals is highly recommended.) If the boom will be moved extensively, arrange for a workman to stay with the pump and put yourself in a position to see the end of the boom (Figure 53).

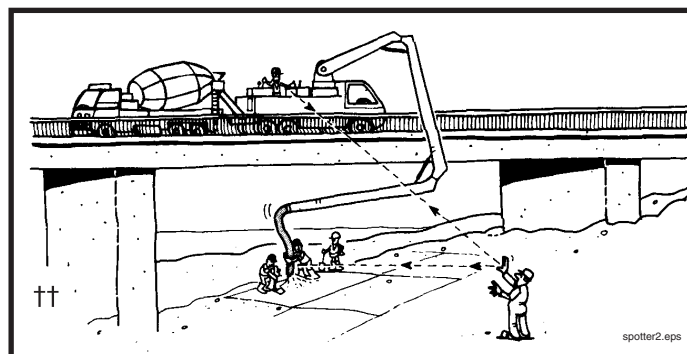

Figure 53
Never pump blind

8.36

⚠ WARNING Always block the discharge end when you must swing a full boom over workers or property. You must stop concrete from falling out of the boom. This can be done with a shut-off valve, or by removing the hose and putting a blanking plug on the last elbow (Figure 54), or by kinking the end hose and securing it in the kinked position. Please note— hoses that can be easily kinked may not be strong enough to withstand the pressure of the pump. Verify the working pressure of the hose against the maximum pressure of the pump before using this type of hose.

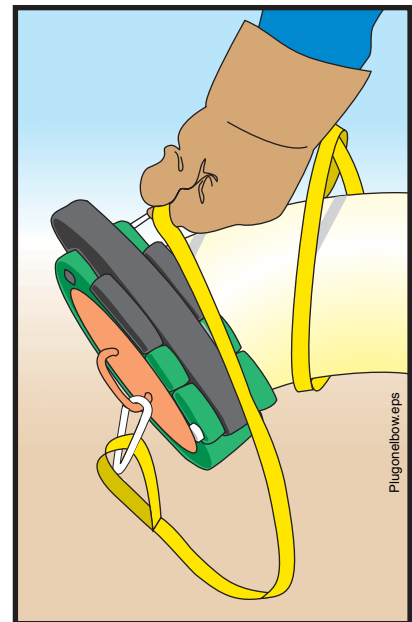











Figure 54
A blanking plug in place on a tip elbow with safety sling

IV. Cleaning The Pump And System

9. Safety Rules For Cleaning The Boom

- 9.1  **WARNING** Do not let down your guard when the pour is completed. Accidents also happen during cleanout and the drive back to the yard. It is important not to become relaxed about job safety until you are no longer on the job.
- 9.2  **WARNING** Watch for electric wires when moving the boom for cleanout or folding the boom for transport!
- 9.3  **WARNING** Using compressed air to clean the boom delivery system should only be done when no other method is practical or as recommended by the manufacturer.
- 9.4  **WARNING** If you have to use compressed air for cleaning the boom you **must** have all of the necessary accessories. Read and understand the complete safety rules regarding cleaning out with compressed air (point 12.4 on page 47 of this Safety Manual). Cleaning with compressed air should only be done by a qualified person.
- 9.5  **WARNING** **Never** use compressed air to blow through rubber hoses or short sections of pipe. In the case of rubber hoses, their flexibility will allow them to “whip” wildly with the force of the air and moving concrete. Short sections of pipe will not have sufficient mass to allow the concrete to move slowly, so there will be rapid expulsion of the material.
- 9.6  **WARNING** If the ball or go devil doesn’t come out of the delivery system after applying compressed air, **you must relieve the pipe of air pressure before opening it.** If the bleed off valve plugs when you are draining the air, the only safe way to proceed is to drill small holes into the pipeline, which will then allow the air to escape. Wear a full face shield when drilling the holes. Pipe you have drilled into is ruined and must be replaced. Drill the holes to relieve the air pressure even if the concrete has set up in the pipe. The pipe is hazardous until the pressure is relieved.
- 9.7  **WARNING** Exercise care when “tapping” on the pipeline to find the location of the cleanout ball. Applying too much force will dent a standard pipe (making it weak and unsafe) and could break the carbide insert of double wall pipe.
- 9.8  **WARNING** It is better to let the pipe be ruined by setting concrete than to risk injury by ignoring safe procedures. Remember, pipeline is replaceable, you are not.

10. Safety Rules For Cleaning The Concrete Valve & Hopper

- 10.1  **WARNING** Tipping hazard! Before moving the unit for cleaning, **fold the boom and secure the outriggers into the travel position.**
- 10.2  **WARNING** Wear protective clothing and equipment when cleaning the concrete pump. Protect against concrete burns and concrete poisoning by wearing rubber boots and gloves during cleanout or any other time that you will be **in** contact with the concrete.

10.3 **⚠ WARNING** Crushing and amputation hazard! **Never put your hands or any other body part into the concrete valve.** Instead, use water jets and the supplied rake (Figure 55).

10.4 **⚠ WARNING** **Never put your hands or any other body part into the machine when the hydraulic system is operational.** If you must remove the grate to chip at hardened concrete, you must first disable the system by taking the transmission out of gear and locking the cab door, or stopping the engine, relieving pressure in the accumulator circuit (if so equipped) and securing the controls against unintended operation. Reinstall the grate before restarting the engine (Figure 55).

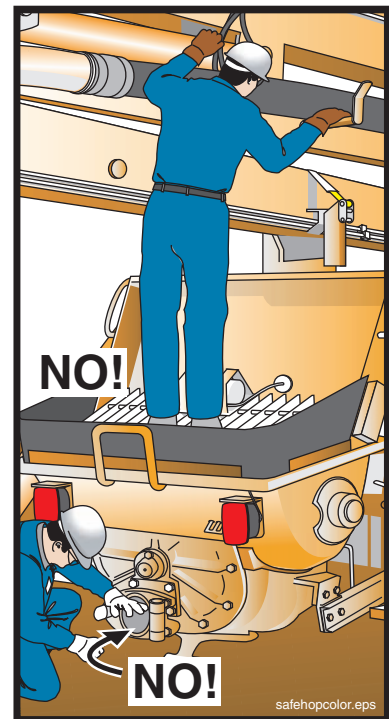

Figure 55
Keep your body parts out of the machine

11. Safety Rules For Cleaning The Water Box

11.1 **⚠ WARNING** Crushing and amputation hazard! Stop the concrete pump before removing the water box covers. If your unit has bolt down guards, do not remove them for cleaning. If there is not a bolt-down guard over the water box, then stop the pump, take the transmission out of gear, and lock the cab so the pump cannot be restarted until you are finished cleaning and the covers are back in place. If a bolt-down grate is installed, you may simply stop the pump from stroking before removing the water box covers. Replace the covers before restarting the pump.

11.2 **⚠ WARNING** If possible, position the folded boom in a slightly raised position when cleaning the water box (watch for wires when raising the boom). The outriggers must be extended and jacked. If the boom is raised, it will be unnecessary to bend over the water box for cleaning.

SAFETY MANUAL

11.3 **⚠️ WARNING** Falling hazard! Be sure of your footing when cleaning the water box.

11.4 **⚠️ WARNING** Crushing and amputation hazard! Do not remove the water box guards for cleaning. Clean the water box with water jets only. **Do not put your hands or any other body part into the water box for cleaning, or at any other time when the machine is running or ready to start.**

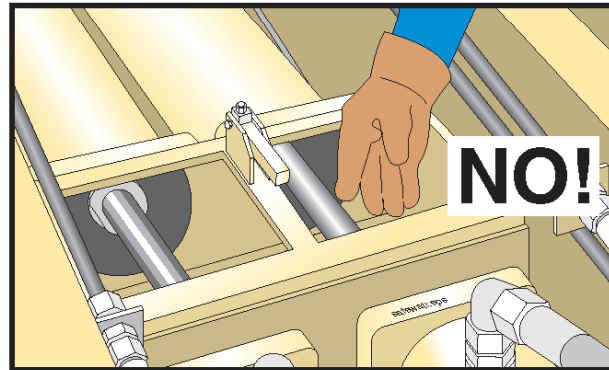

Figure 56
Keep your hands out of the waterbox

12. Safety Rules For Cleaning A Separately Laid Pipeline

12.1 **⚠️ WARNING** Flying particle hazard! Clear the discharge area of personnel and equipment before forcing a ball or go devil through the pipeline, even if you are cleaning with water. Some air will be trapped in the pipeline, and the trapped air will become compressed before discharge.

12.2 **⚠️ WARNING** Short pipelines and single pipe sections should be cleaned by removing the clamps and dumping the pipe sections. Remember to lift with your legs, not with your back.

12.3 **⚠️ WARNING** The point of discharge must be controlled. Use a ball catcher or some other containment device at the point of discharge, even when cleaning with water.

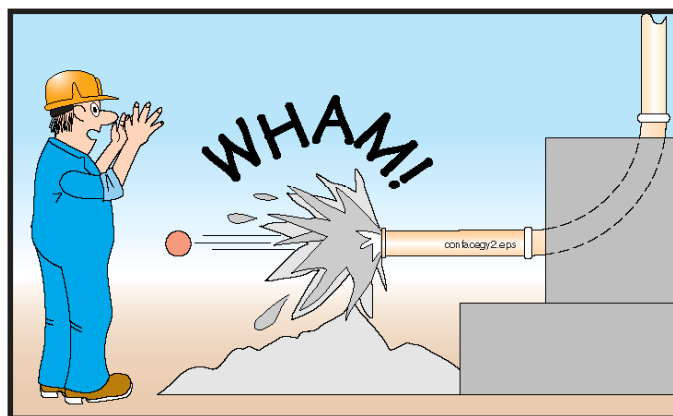

Figure 57
Cleaning with compressed air can be extremely hazardous if you don't follow the safety rules

12.4

⚠ WARNING Blowing out with compressed air creates potential hazards! Serious injury or death could result if you do not adhere to these safety points.

- **Blowing out must be performed under the supervision of a qualified person.** (See the glossary for the definition of *qualified person*.)
- **Blowing out requires two people!** One trained person must be at the inlet end to operate the air insertion, and the other trained person must be near (but safely back from) the discharge point to monitor the discharge and to make sure that no one enters the hazard area.
- **No pipe bends or flexible delivery hoses may be connected to the end of the pipeline during the blowing out process,** unless there is a pre-planned cleanout station erected to route the discharge into the ready mix truck.
- **The point of discharge must be controlled. Clear the discharge area of personnel and equipment** before beginning the blowing out process. Do not allow anyone to enter the area during the blow out process. If a ball catcher is used, be aware of which type you have, and adjust your procedure accordingly. Ball catcher types are described in paragraph 7.23 on page 31.
- **The concrete outlet must be positioned high enough to permit easy discharge of the material.**
- If you are going to divert the discharge into a discharge pipe system, **you must lubricate the discharge line with slurry, or a plug could occur.**
- **The pipe cleaning blow out head must be equipped with a properly sized air discharge regulator valve and a separate water/air inlet.** The two openings should be spaced apart far enough that a blowout ball could not cover both openings at once (Figure 58).

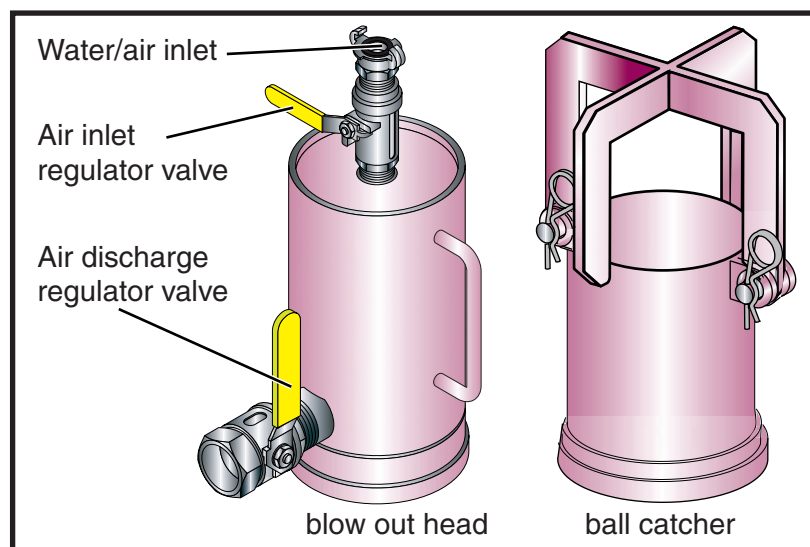

Figure 58
Ball catcher and blow out head

- The plug or go devil must be thick enough to prevent compressed air flow around the plug into the concrete.

SAFETY MANUAL

- The pipeline must not be disassembled until it has been completely relieved of air. Be sure of this! (See Figure 59.)

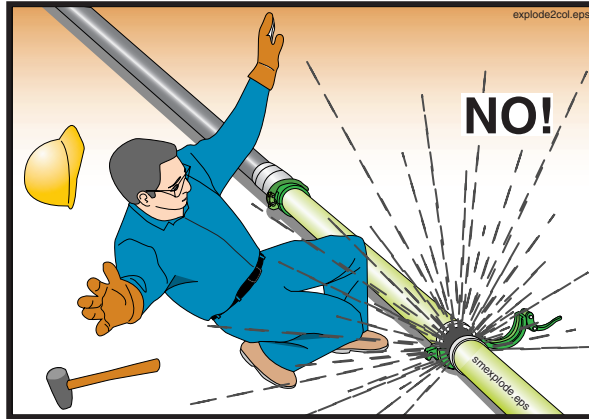

Figure 59
Never open a pressurized pipeline

- Do not use compressed air to blow out concrete delivery hose, single pipe sections and short pipelines up to a length of 40 feet. Hoses will jump and move unpredictably; short pipelines don't have enough concrete to resist the force of the air, causing it to discharge too quickly, like a cannon (Figure 60).

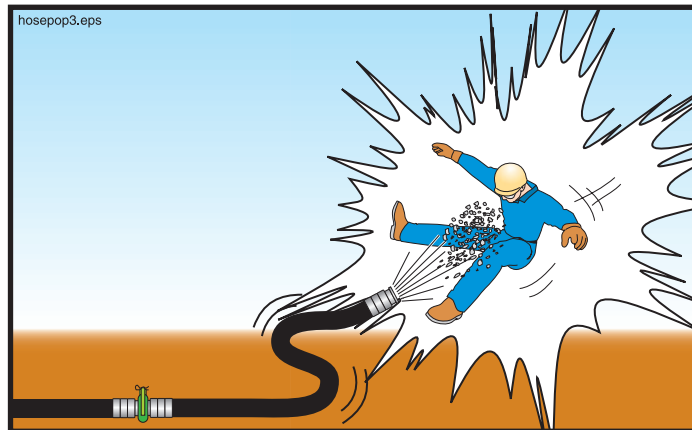

Figure 60
Never use air to blow out hoses or short pipelines

- When air pressure begins to drop rapidly, shut off the air supply from the compressor, and immediately begin bleeding air out of the pipeline. (The drop in pressure signifies that the pipeline is almost empty of concrete.)

12.5



WARNING When blowing out a vertical line, a shutoff valve is required to prevent the following scenario.

1. (See diagram A in Figure 61.) Without a shutoff valve installed, the pipeline is disconnected from the pump. Immediately, the concrete drains out of the vertical sections of pipe, leaving concrete in both horizontal sections, and air trapped in between.

- (See diagram B in Figure 61.) The ball is inserted, and pushed with compressed air. This also compresses the air that is trapped in the vertical sections of pipe. The trapped air will be violently expelled when it reaches the end of the pipe, but the pipe will not yet be empty.

A shutoff valve installed at the bottom of the vertical run will prevent this hazardous situation. The shutoff valve must be capable of handling the maximum concrete pressure of the pump and, of course, must be installed before the pour begins. Several different styles are available, ranging from a manually operated flat gate that is put into place with a hammer to fully hydraulic types that will also divert the concrete to a different pipeline. With a shutoff valve installed, you can proceed as indicated below.

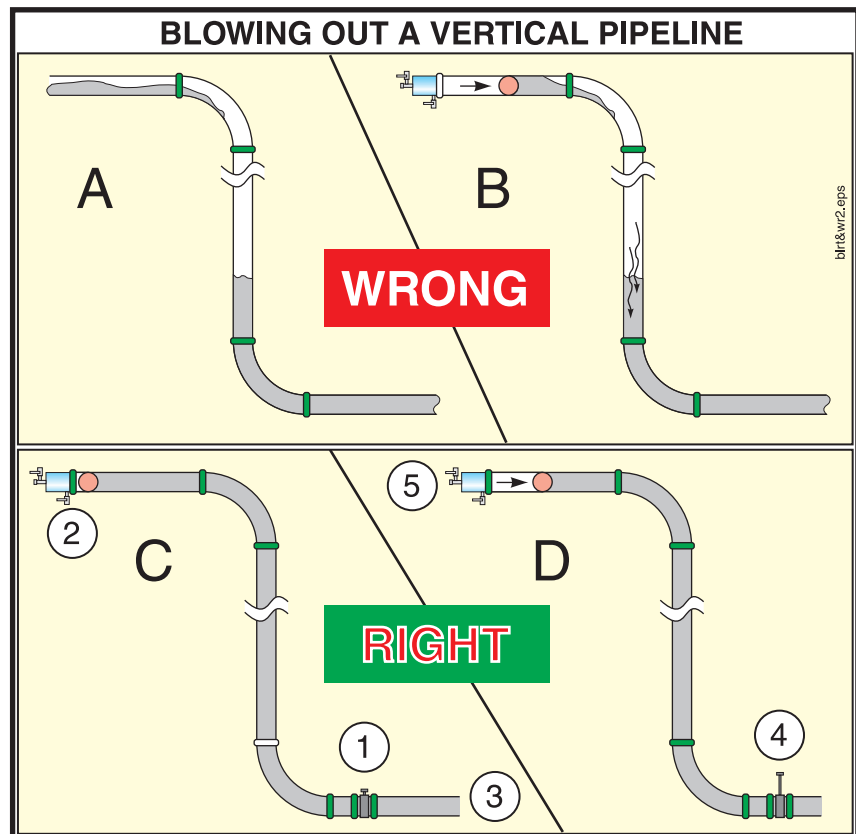

Figure 61
Blowout of a vertical line

12.6

⚠ WARNING Blowing out vertical sections of pipe (for example on a high rise building) requires additional safety precautions.

- Know where the discharge area for blowing out will be before the pour begins.** Ready the area and accessories before the pour begins so you will not waste time when pumping is completed.
- Blowing out with compressed air requires two qualified persons.**

SAFETY MANUAL

3. **The persons at both ends of the pipeline must be able to communicate without delays**, which means you must establish communications (for example, with a radio).
4. **When pumping is complete, close the shutoff valve before disconnecting the pipeline from the pump** (item 1, Figure 61). Failure to do this will cause the concrete to fall out of the vertical sections of pipe, leaving concrete in the horizontal sections of pipe and an air pocket in the vertical sections. This does not apply if you are using a switching (diversion) valve.
5. Install the ball(s) in the pipeline, secure the blow out head and hook up the air compressor. **Do not apply the air yet!** (Item 2, Figure 61.)
6. If you will be diverting the discharge to a cleanout area, lubricate the discharge line with slurry, or a plug could occur.
7. **Position the ready mix truck at the cleanout standpipe**, or install the ball catcher or other containment device at the end of the discharge line. (Item 3, Figure 61.)
8. **Clear the discharge area of personnel.** You must allow no one to enter the discharge area until the pipeline is depressurized.
9. **Divert the vertical pipe line to the clean out area, or open the shutoff valve in the delivery pipe line now.** Allow gravity to start the concrete moving through the discharge line. As the concrete falls from the vertical sections, it will take the ball with it, making it impossible to trap air in the line. (Item 4, Figure 61.)
10. **Apply the compressed air to the pipeline.** Close communications must be maintained at this time. Add only enough air to keep the concrete moving. Do not allow the concrete to accelerate. (Item 5, Figure 61.)
11. **When concrete starts to accelerate, shut-off the air supply from the compressor, and open the air regulator to bleed air from the line.** Rapidly accelerating concrete indicates that the pipeline is almost empty. After the ball has been expelled from the pipeline, leave the air regulator open to be sure that all air is removed from the system.
12. All the rules for blowing out found in point 12.4 on page 47 also apply to blowing out a vertical pipe line. These rules are in addition to the general “cleaning a pipeline with compressed air” rules.

12.7

 **WARNING** Never use compressed air to attempt to clear a blockage! It is unsafe and unnecessary. If the pump pressure can't move it, air pressure won't either.

V. Maintenance Of The Machinery

13. Safety Rules Regarding Inspection

- 13.1 **⚠ WARNING** It is imperative that your boom, outriggers, and other structural members be inspected by a certified boom inspector on a regular basis. The results should be documented carefully and a record kept. Consult the manufacturers recommendations for the proper interval for your machine.
- 13.2 **⚠ WARNING** Visually inspect your unit each day before it is put into operation. If any problem is found that will affect the safe operation of the pump, don't use the pump until it is repaired!
- 13.3 **⚠ WARNING** Any structural problem found on the placing boom, outriggers, or tower section of the unit should be reported to the manufacturer so that proper repair procedures can be designed and implemented. You do not need to report any structural problem that has been previously reported and for which a repair procedure has already been designed and implemented.
- 13.4 **⚠ WARNING** If safety decals are faded, missing, damaged, or otherwise unreadable, they must be replaced immediately. Contact the manufacturer of your unit to obtain replacements.
- 13.5 **⚠ WARNING** If safety devices or guards are removed for inspection purposes, they must be replaced before someone uses the machine.
- 13.6 **⚠ WARNING** Pay attention to the *Operation Manual* and manufacturer's service bulletins regarding maintenance and inspection procedures and intervals.
- 13.7 **⚠ WARNING** If inspection reveals something that looks wrong, or even suspicious, report it to the manufacturer for consideration. Don't just assume that it's OK.
- 13.8 **⚠ WARNING** Inspect the tip hose safety cable and mounting hardware on a regular basis. Replace it if it becomes old, frayed, or rusted.
- 13.9 **⚠ WARNING** Inspect the boom tie down and boom rest assemblies regularly (if your unit is so equipped). The boom must not be allowed to bounce during travel.
- 13.10 **⚠ WARNING** Visual inspection of the concrete pump circuits and safety devices should be done daily. Hands on inspection and documentation of results should be done weekly, or at least when preventive maintenance is scheduled.

SAFETY MANUAL

13.11

⚠ WARNING Do not neglect the delivery pipeline, clamps, or hoses. Check them often for wear, dents, and frays. Never send a unit to a job with a worn or damaged delivery system. Ultrasonic thickness testers are more accurate than the tap method.

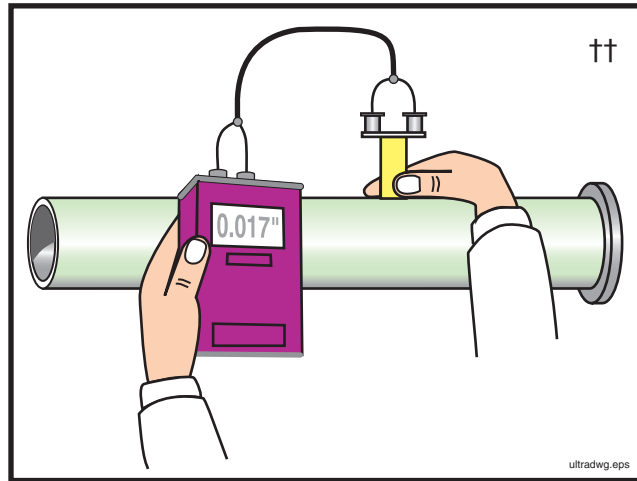

Figure 62
Check delivery system wall thickness with an ultrasonic thickness tester

14. Safety Rules Regarding Scheduled Maintenance

14.1

⚠ WARNING Proper and timely maintenance is important to the safe operation of a concrete pump and placing boom. The proper procedures are outlined in the operation manual supplied with the pump. Do not put it off. Do not treat it lightly. Do not “fudge” results. The lives of the operator, oiler, and workers on the job are depending on it.

14.2

⚠ WARNING Keep the machine clean! Oil spills, grease, loose tools, and displaced accessories are hazards.

14.3

⚠ WARNING Pins should be used on all delivery system clamps. Clamps that will hang over workers, and clamps used on system that will be dragged shall be pinned (Figure 63).

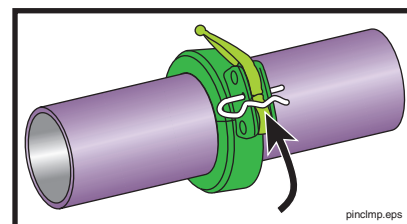

Figure 63
Pin the clamps

- 14.4 **⚠ WARNING** Be sure that you are installing the correct clamps for the types of pipe ends used. Never try to mate dissimilar pipe ends unless using a clamp specifically made for this purpose. See the comparison regarding weld-on ends on page 72 in the appendix of this manual.
- 14.5 **⚠ WARNING** When installing new pipe and/or hose on the machine be sure that it is capable of handling the maximum concrete pressure of the pump.
- 14.6 **⚠ WARNING** Remember that boom pipe cannot weigh more than 10.14 pounds per foot, when empty. Certain models and brands may have different requirements. Check the operation manual for your machine.
- 14.7 **⚠ WARNING** If safety devices or guards are removed for servicing, they must be replaced before the machine is put back in service.
- 14.8 **⚠ WARNING** Do not change the maximum relief valve setting on any hydraulic circuit without permission from the manufacturer. **Never** change an accumulator circuit pressure setting without specific instructions from the manufacturer.
- 14.9 **⚠ WARNING** Never make unauthorized modifications to structural members or pressure circuits.
- 14.10 **⚠ WARNING** You must **replace, not repair** damaged hydraulic or concrete hoses or pipes.
- 14.11 **⚠ WARNING** Never try to repair a machine using worn, damaged, or defective components.
- 14.12 **⚠ WARNING** Welding on the boom, outriggers, tower, or any other structural member may be done **only** by a welder certified to A.W.S. D1.1 (Sections 3, 5 and paragraph 9.25 of Section 9). All structural welding must be done to the manufacturer's specifications.
- 14.13 **⚠ CAUTION** Never allow welding current to travel through bearings or hydraulic cylinders. Keep the ground cable on the component that is being welded.
- 14.14 **⚠ CAUTION** Electronic components can be destroyed by welding current. Before welding on the unit, you must disconnect the battery cables, and unplug all radio remote control power wires. If you have a proportional boom system, the proportional amplifiers must be removed from the mother board before welding. If in doubt, contact the service department of the manufacturer for instructions before proceeding.

15. Safety Rules When Servicing The Machinery

- 15.1 **⚠ WARNING** Repairs should be carried out by qualified workshop personnel (See the glossary for the definition of *qualified personnel*.)

SAFETY MANUAL

- 15.2 **⚠ WARNING** Read and understand the maintenance procedures in the *Operation Manual* of the machine before attempting any repairs. If in doubt, call the manufacturer. Incorrectly done repairs affect the safe use of the machine.
- 15.3 **⚠ WARNING** Burn hazard! Never work on a hot hydraulic system.
- 15.4 **⚠ WARNING** If it is necessary to unfold the placing boom to do maintenance work, the outriggers must be extended and jacked, just as if the machine were on a job site. If you are not an operator, have the operator set up the machine for you. The need to repair the machine does not qualify you to operate the machine.
- 15.5 **⚠ WARNING** Electrocution hazard! If it is necessary to unfold the placing boom to do maintenance work, you must watch for overhead power lines. You must maintain a minimum of 17 ft. (5 meters) clearance between the power line and any part of the unit.

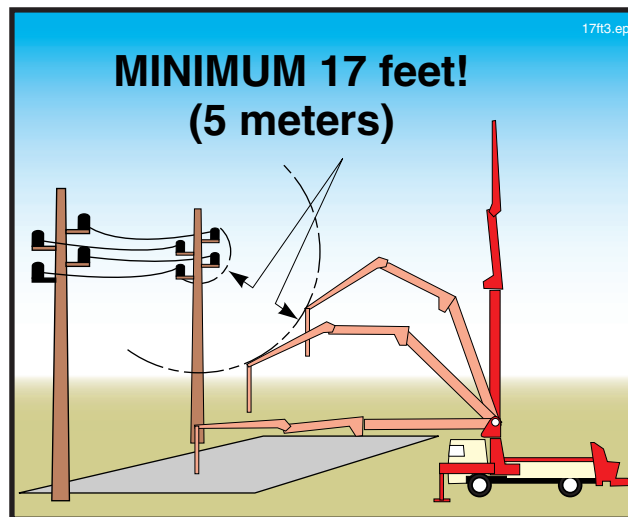

Figure 64
Watch for power lines if you must unfold the boom

- 15.6 **⚠ WARNING** Falling hazard! If you cannot work at ground level, you must find and use a suitable work platform, a tie-off harness system, or otherwise secure yourself from falling.
- 15.7 **⚠ WARNING** If maintenance work requires that you use a crane, hoist, fork truck, or similar machine, read and understand the safety regulations for that equipment. Remember, **the boom may not be used as a hoist or crane!**
- 15.8 **⚠ WARNING** Crushing hazard! **Secure the placing boom and relieve all pressure before working on the boom hydraulic system.**
- 15.9 **⚠ WARNING** Only operators should operate the unit. If work on the machine requires that it be operated and you are not qualified as an operator, you must get someone who is qualified to assist you.

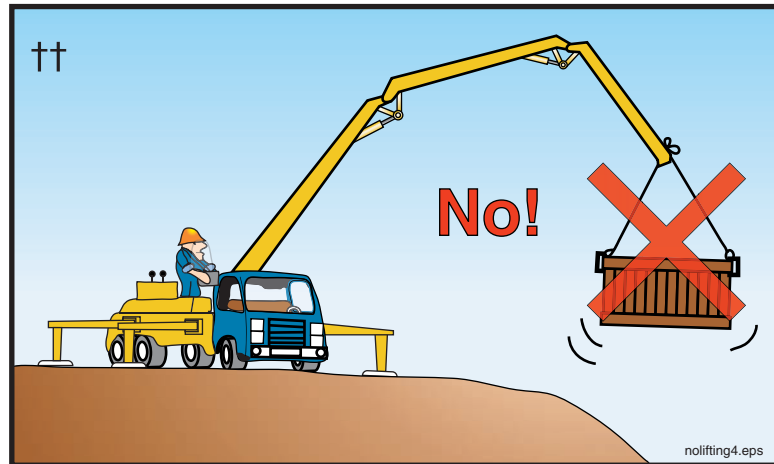

Figure 65
No lifting with the boom

- 15.10** **⚠ WARNING** Electrocutation hazard! **Repair work on high voltage electrical systems must be done by qualified electricians.** For this rule, high voltage means anything over 24 volts.
- 15.11** **⚠ WARNING** Explosion hazard! **Be sure that you understand the potential danger of spring loaded or compressed gas components before you service them.** (Examples: nitrogen accumulators, gas springs for toolbox doors, tires, brake chambers.) If you don't know the dangers, call the manufacturer **before** beginning work!
- 15.12** **⚠ WARNING** If you will be working in a hidden area inside the machine, lock it out as follows.
- With a gas or diesel engine, remove the ignition key and place a *Do Not Operate* sign on the controls. Carry the key with you.
 - With an electrically driven pump, lock out the main breaker and tag the controls.
- The above rules are one simple “Lock Out-Tag Out” procedure. There may be state or local regulations that require a more advanced or stringent Lock Out-Tag Out program. Be aware of the regulations in your area.
- 15.13** **⚠ WARNING** **Never activate the system hydraulics without checking if another workman is in a hidden position.** Always yell “clear” before starting the engine or electric motor, and allow time for response.
- 15.14** **⚠ WARNING** **Never work on a pressurized hydraulic system.** Stop the engine or electric motor and relieve the accumulator circuit (if so equipped) before you open the hydraulic system.
- 15.15** **⚠ WARNING** **Never use gasoline or diesel fuel as a cleaning solvent.** This is critical to remember when cleaning hydraulic oil reservoirs, because gas and diesel fuels are highly explosive and **traces left in the oil may ignite when compressed!**

SAFETY MANUAL

15.16

⚠ WARNING Remember to mount and dismount the unit using the “3 Point Rule.” One hand and two feet or two hands and one foot are to be in contact with a secure surface at all times (Figure 66).

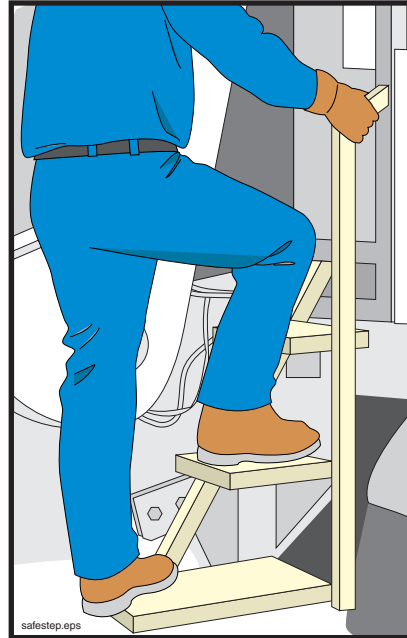

Figure 66
The 3 Point Rule

15.17

⚠ WARNING **Inspect the repairs.** After modifications to structural members (boom, outriggers, tower, etc.) the repair must be inspected by qualified personnel before use.

15.18

⚠ WARNING **Always use the correct tools for the job.** Tools should be kept clean and in good condition.

15.19

⚠ WARNING If you see a co-worker engaging in an unsafe practice, warn him about the dangers. Safety is always in the hands of those on the job!

15.20

⚠ WARNING After any repair is completed, test the function of the repaired part to be sure that repairs were done correctly.

VI. Co-worker Safety

16. Safety Rules For Workers Assigned To The Pump.

- 16.1 **⚠ WARNING** You must know how to stop the pump and boom. Have the operator show you the locations of the emergency stop switches (Figure 67).

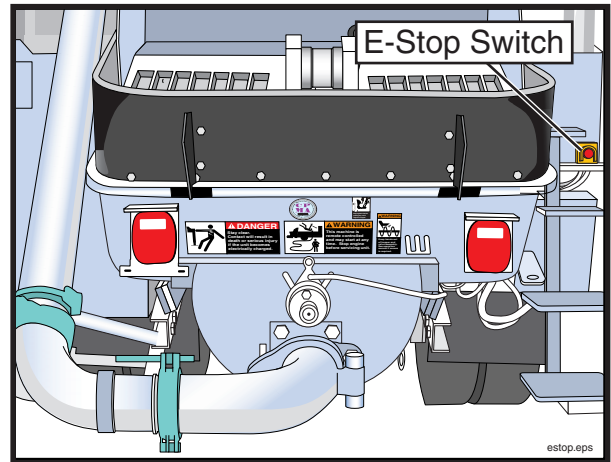
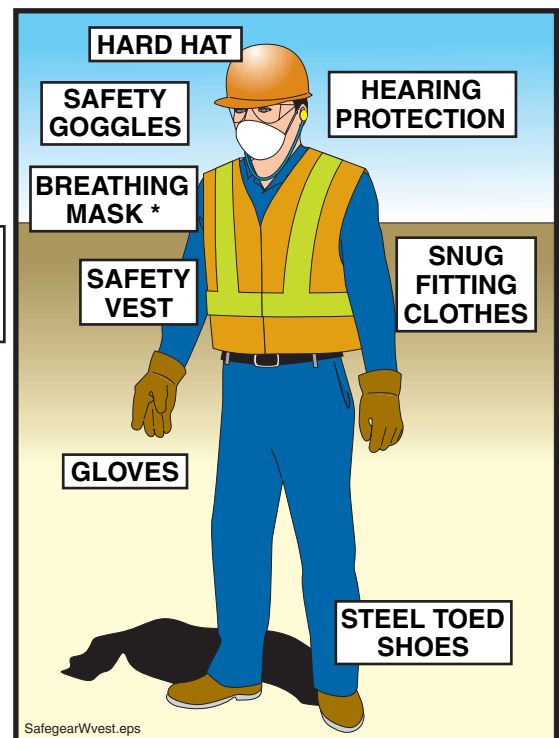

Figure 67
Know how to stop the unit in an emergency

- 16.2 **⚠ WARNING** You should wear the same personal protective equipment as the operator. Goggles, hard hat, ear protection, and rubber gloves are especially important when working near the hopper (Figure 68).



* Breathing mask needed when cement dust (or other toxic dust) is present in the air.

Figure 68
Wear the same personal protective equipment as the operator

SAFETY MANUAL

16.3

⚠ WARNING **Electrocution hazard!** If the pump or boom becomes energized with high voltage and you are in contact with **any** part of it, you are at **risk of electrocution!** You should monitor the movement of the boom and **alert the operator if the boom comes within 17 feet of an electrical wire.** (See Figure 69.)

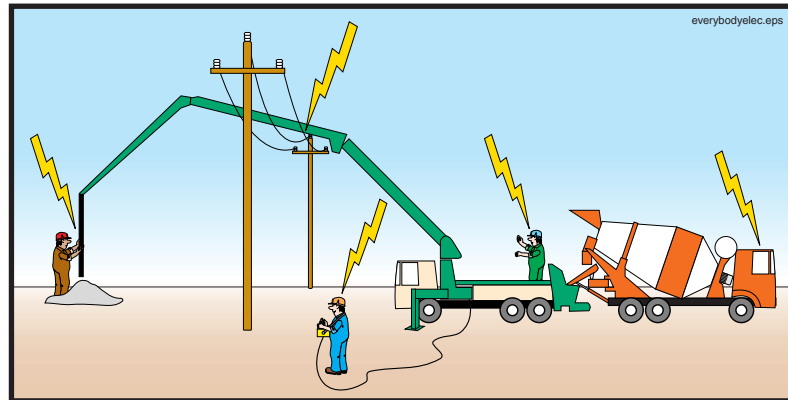

Figure 69

If the pump becomes energized, everything that touches the pump is also energized

16.4

⚠ WARNING Keep an eye on the movements of the boom, even when there are no electrical wires nearby. Alert the operator if the boom is nearing any obstruction or hazard. Where job site safety is concerned, two sets of eyes and ears are better than one.

16.5

⚠ WARNING **Crushing hazard.** Never, ever position yourself between the ready mix truck and the pump! Stand to the side, where the driver can see you (Figure 70).



Figure 70

Never stand between the ready mix truck and the pump

16.6

⚠ WARNING When backing in ready mix trucks, use clear and concise hand signals (Figure 71).

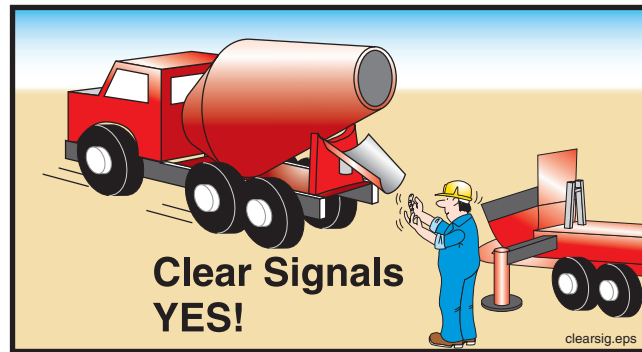

Figure 71
Use clear, concise hand signals

- 16.7** **⚠ WARNING** Do not allow the ready mix driver to put concrete in the pump hopper until the pump operator gives him the OK. Filling the hopper early can cause the pump to plug.
- 16.8** **⚠ WARNING** If you see foreign material that could create a blockage coming from the ready mix truck, alert the operator to stop the pump. Do not attempt to remove the material from the hopper or grate while the hydraulic system is ready to work. (See point 16.17 on page 62.) If necessary, depress the E-stop button to stop the pump and alert the operator.
- 16.9** **⚠ WARNING** Never allow the ready mix driver to clean out in the hopper, because it can create a blockage. (Water will wash the cement and fine sand from the course aggregate causing segregation.)
- 16.10** **⚠ WARNING** Do not operate the pump or boom unless you are also a trained operator and the regular operator has released the controls to you. **There must not be more than one operator at a time.** This does not apply to stopping the pump or boom if there is a need to do so.
- 16.11** **⚠ WARNING** Do not let the concrete level in the hopper become low! If air is sucked into the material cylinders, the pump will compress the air. Compressed air always poses a hazard as it is expelled from the hopper or the delivery pipeline (Figure 72). If air is taken into the material cylinders, take the following steps to minimize the hazard:
1. Stop the pump immediately. Hit the emergency stop button if that is the quickest way to stop the pump. There will be an expulsion of compressed air the next time the concrete valve shifts. If possible, fill the hopper with concrete to help contain the expulsion.
 2. Alert the operator of the problem. It is his job to know the procedures for safe removal of air from the pump and delivery system. These procedures include pumping in reverse for a couple of strokes.
 3. Persons standing at the discharge end or near the delivery line must be warned to move away until all of the air has been purged. Warn them to stay

SAFETY MANUAL

a reasonable and prudent distance beyond the reach of the end hose or point of discharge (Figure 72).

4. When the pump is restarted, the slowest possible speed should be used until **all** air is removed from the pipeline. Don't assume that the first little air bubble is the end of the compressed air.
 5. Do not allow anyone near the discharge until concrete runs steadily from the end and there is no movement of the delivery system.
- If workers are positioned in high or precarious places, warn them to expect a loud sound as the air escapes the pipeline. (Warn them even if they are well away from the discharge.) That way, we can prevent the worker from falling as a result of being startled by the noise.

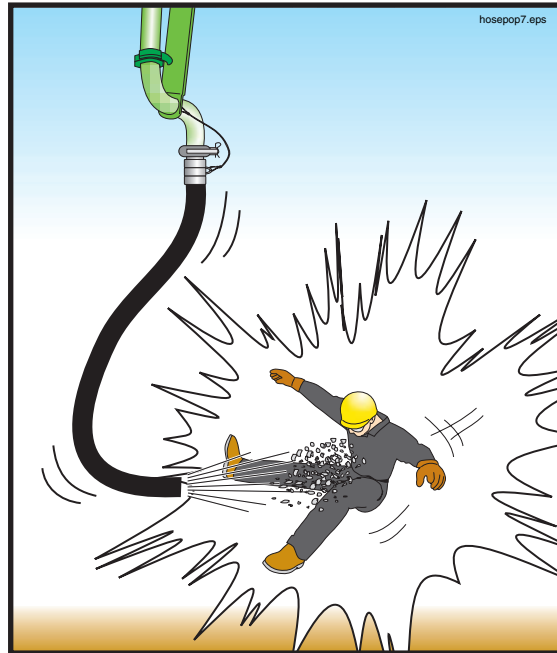

Figure 72
Remove everyone from the discharge area whenever the pump is first starting, restarting after moving, or if air has been introduced into the line

16.12

⚠ WARNING When initially priming the delivery system, when restarting after moving, when restarting after adding or removing hoses, or whenever air has been introduced into the line, warn everyone to stay away from the discharge until concrete runs steadily and there is no movement of the delivery system. Personnel should stay back a reasonable and prudent distance beyond the reach of the end hose or point of discharge (Figure 72). Air will be in the line when first starting, when restarting after moving, when a blockage has been successfully removed by “rocking” the concrete, and after the line has been taken apart or opened for any reason.

16.13 **⚠ WARNING** Never use compressed air to clear a blockage! The operator is responsible for knowing the safe blockage removal procedures. It is unsafe and unnecessary to use compressed air. If the pump pressure can't move it, air pressure won't either.

16.14 **⚠ WARNING** Never stand on, sit on, or straddle a pipeline while it's in use, or whenever it is pressurized. Pipeline wears out with each stroke of the pump. If the pipe bursts, you want to be to the side of it, not on top of it (Figure 73).



Figure 73
Never straddle or sit on a pressurized pipeline

16.15 **⚠ WARNING** Expulsion hazard! (See Figure 74.) Never open a pipeline that is under pressure. The pump must be run in reverse for at least two strokes and then stopped before opening a pipeline. If you don't know how to reverse the pump, have the operator do it. If the pipeline is pressurized with air, do not open it. The operator is responsible for knowing how to safely release the air pressure.

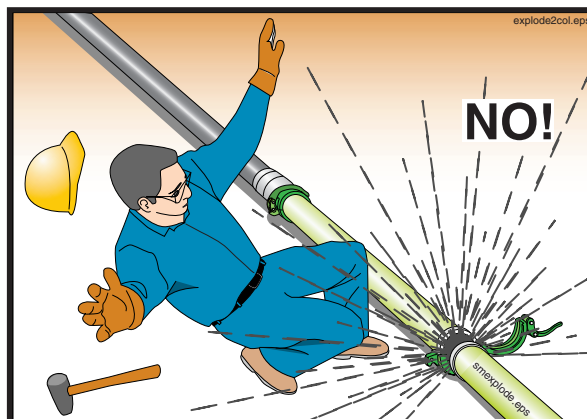

Figure 74
Never open a pressurized pipeline

16.16 **⚠ CAUTION** Be careful when handling pipeline or any other heavy object. Learn how to lift without using your back. Get assistance if needed.

SAFETY MANUAL

16.17

⚠ WARNING Crushing/amputation hazard! Never put your hands, feet, or any other body part into the water box, concrete valve, or hopper when the hydraulic system is operational or ready to operate! Never stand on the hopper grate! (See Figure 75.)

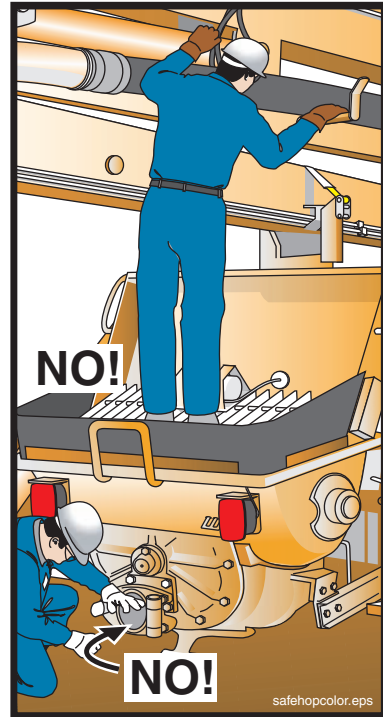

Figure 75
Never put your body in the machine!

16.18

⚠ WARNING Never lift or remove the hopper grate for any reason (Figure 76).



Figure 76
Lifting hopper grate exposes the agitator and the concrete valve

16.19

⚠ WARNING Do not remove the water box covers or grates when the machine is stroking (Figure 77). If you must remove the water box cover (to add water, for example), and there is not a bolt-down grate over the water box, then stop the pump and engine, and put the key in your pocket so it cannot be restarted

until you are finished and the covers are back in place. If a bolt-down grate is installed, you may simply stop the pump from stroking before removing the water box covers. Replace the covers before restarting the pump.

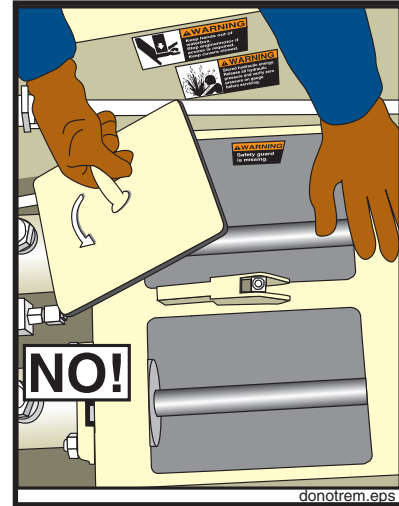

Figure 77
Do not remove the water box covers when the machine is stroking

16.20

WARNING Mount or dismount the pump or truck using the *3 Point Rule*. One hand and two feet or two hands and one foot are to be in contact with a secure surface at all times (Figure 78).

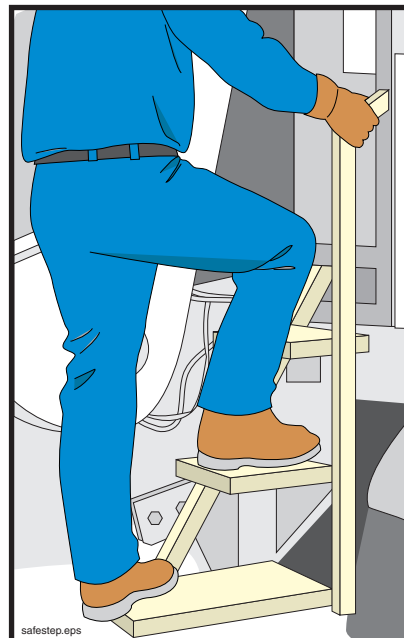

Figure 78
The 3 Point Rule

16.21

WARNING Keep unauthorized personnel off of the pump.

SAFETY MANUAL

17. Safety Rules For The Placing Crew

17.1

⚠ WARNING **Electrocution hazard!** If the pump or boom becomes energized with high voltage and you are in contact with **any** part of it, you are at **risk of electrocution!** You should monitor the movement of the boom and **alert the operator if the boom comes within 17 feet of an electrical wire.** (See Figure 79.)

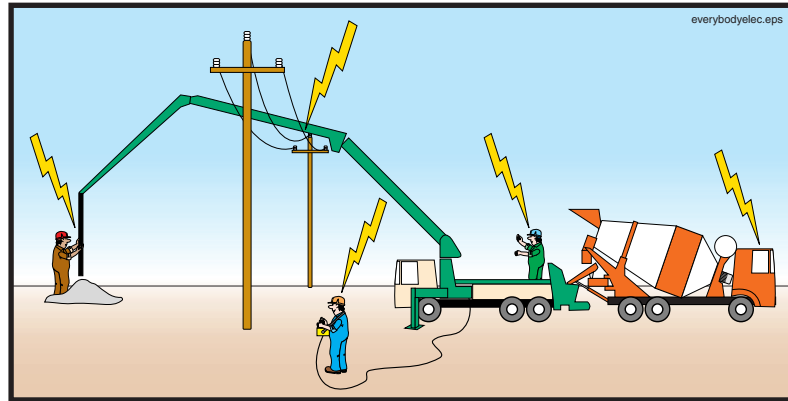

Figure 79

If the pump becomes energized, everything that touches the pump is also energized

17.2

⚠ WARNING If the boom can contact overhead wires a spotter must be used to warn the operator if the boom is coming near the wires (Figure 80.)

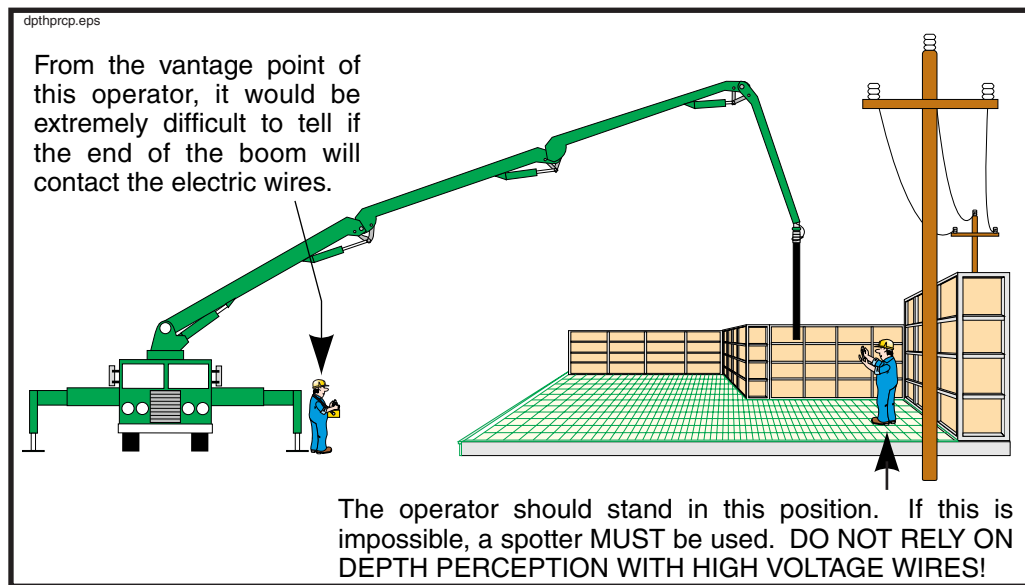

Figure 80

Use a spotter near obstructions or wires

17.3 **⚠ WARNING** Keep an eye on the movements of the boom, even when there are no electrical wires nearby. Alert the operator if he is nearing any obstruction or hazard. Where job site safety is concerned, two sets of eyes and ears are better than one.

17.4 **⚠ WARNING** Wear Personal Protective Equipment (P.P.E.) when working around a concrete pump (Figure 81). The gloves should resist concrete lime burns. If you will be working **in** the concrete, protect your feet and hands with rubber boots and gloves.



Figure 81
Wear Personal Protective Equipment (P.P.E.)

17.5 **⚠ WARNING** When the operator is initially priming the delivery system, restarting after moving, restarting after adding or removing pipes or hoses, or any time that air has been introduced into the delivery system, stand a reasonable and prudent distance away from the tip hose or point of discharge. Do not get near the discharge until material runs steadily and there is no movement of the delivery system. (Figure 82). Compressed air in the line can cause rubber hose to move violently. If the operator tells you that air is coming in the delivery system, proceed as follows:

- Get to ground level (if in a high place) and remain well away from the discharge or at least take cover.
- Stay away from the discharge. Be sure that **all** the air is gone before getting near the point of discharge again. It is the operator's job to know when it's safe to go back to normal pumping.

SAFETY MANUAL

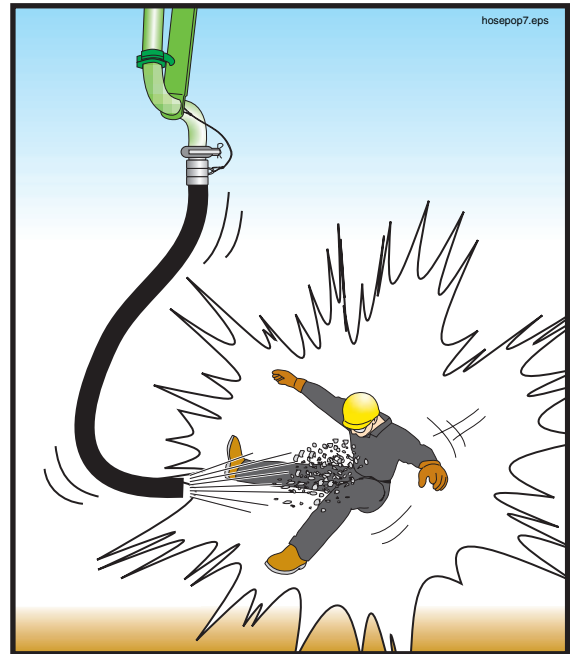

Figure 82
 Stay away from the point of discharge when starting or restarting, and when there's air in the pipeline

- 17.6 **⚠ WARNING** Never use compressed air to clear a blockage! It is unsafe and unnecessary. If the pump pressure can't move it, air pressure won't either. Stand away from the discharge and the line if anyone attempts to use compressed air in this manner.
- 17.7 **⚠ WARNING** Do not look into the end of a plugged hose or pipe!
- 17.8 **⚠ WARNING** When the pump crew is using compressed air to clean the boom or system pipeline, stay away from the discharge area. **Never try to hold down a pipe or hose that is being cleaned with air.**
- 17.9 **⚠ WARNING** Never open a pressurized pipeline (Figure 83). The pump operator must release the pressure before you open the line. If the line is pressurized with compressed air, let the operator release the pressure and verify that the air has escaped before you proceed.

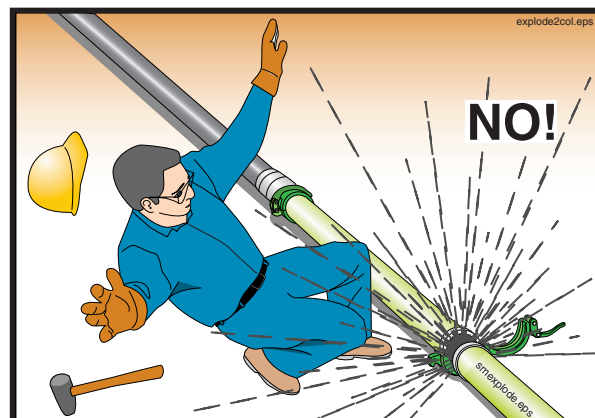

Figure 83
 Never open a pressurized pipeline

- 17.10 **⚠ WARNING** After removing pipe sections you must **reassemble using gaskets and clamps**. Pipelines assembled without gaskets will leak cement and water, which can cause a blockage.
- 17.11 **⚠ WARNING** Concrete is being moved through the delivery system by pressure. Failure of a pipe, clamp, hose, or elbow is possible. For this reason, spend as little time as possible standing under the boom, and wear protective clothing.
- 17.12 **⚠ WARNING** The hose man should not hug the hose, but hold it with both hands, to allow the hose to move freely (Figure 84).



Figure 84
Do not hug the boom hose

- 17.13 **⚠ WARNING** The hose man should not walk backwards (Figure 85). Walking forward will allow him to see obstacles and avoid tripping.

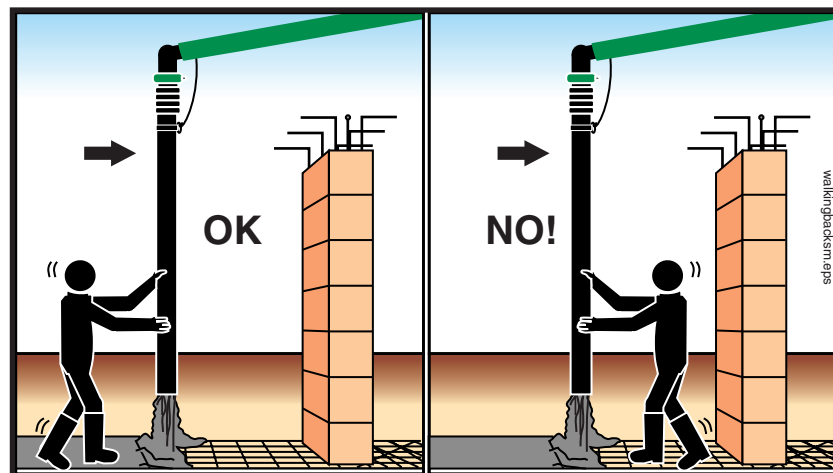

Figure 85
Do not walk backwards, stay out of the path of the boom

- 17.14 **⚠ WARNING** The hose man should never position himself between the boom or boom hose and any fixed object like a wall or column (Figure 85).

SAFETY MANUAL

17.15

⚠ WARNING Do not kink the end hose. Kinking will cause the pump to create maximum concrete pressure. The pump may unkink the hose by force! (See Figure 86.)

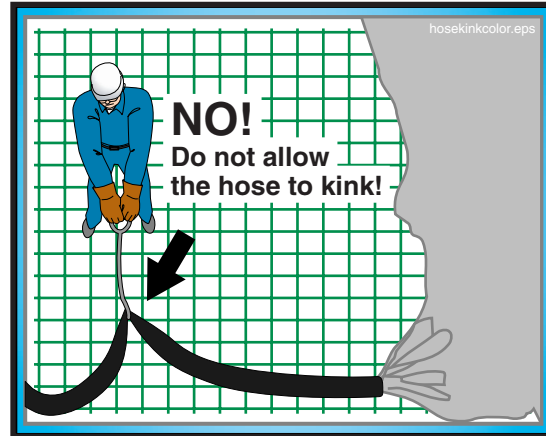

Figure 86
Never kink the hose;
Never hold the hose
with your shoulder

17.16

⚠ WARNING Never try to support the tip hose with your back or shoulders. Let the hose hang from the boom (Figure 86).

17.17

⚠ CAUTION Be careful when handling pipeline or any other heavy object. Learn how to lift without using your back. Get assistance if needed.

17.18

⚠ WARNING Crushing hazard! Never position your hands or any body part between the end of the delivery system and a fixed object (e.g., between the tip hose and the concrete form) (Figure 87). Watch for clamps lowering with the line, because they have a larger diameter than the pipes/hoses they connect.

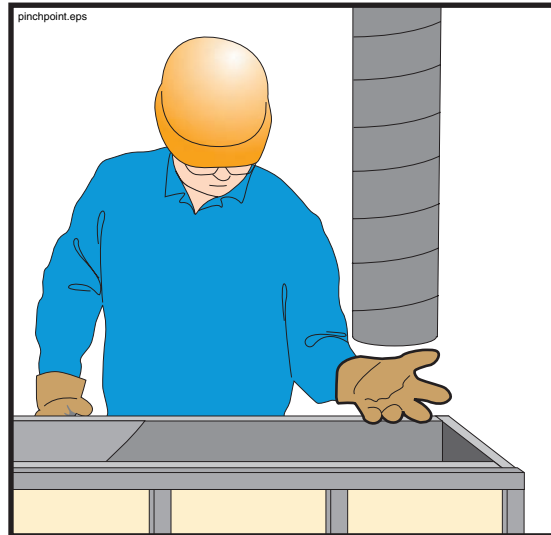

Figure 87
Watch out for the pinch points

17.19

⚠ WARNING Do not allow the boom hose to get lower than two feet above the deck to prevent the boom hose from hitting the feet of the hose man, and to prevent the hose opening from being blocked by the deck, which could cause the hose to whip.

17.20

⚠ WARNING Falling hazard! When pouring columns, slabs, or walls above ground, secure yourself from falling.

17.21

⚠ WARNING Never stand on, sit on, or straddle a pipeline while it's in use, or whenever it is pressurized (Figure 88). Pipeline wears out with each stroke of the pump. If the pipe bursts, you want to be to the side of it, not on top of it.



Figure 88
Never straddle or sit on a
pressurized pipeline

SAFETY MANUAL

17.22 **WARNING** To avoid confusion and conflicting signals, only one person should signal the pump operator.

17.23 **WARNING** Before the pour begins, the hose man, the operator and the spotter should agree on the hand signals (Figure 89).

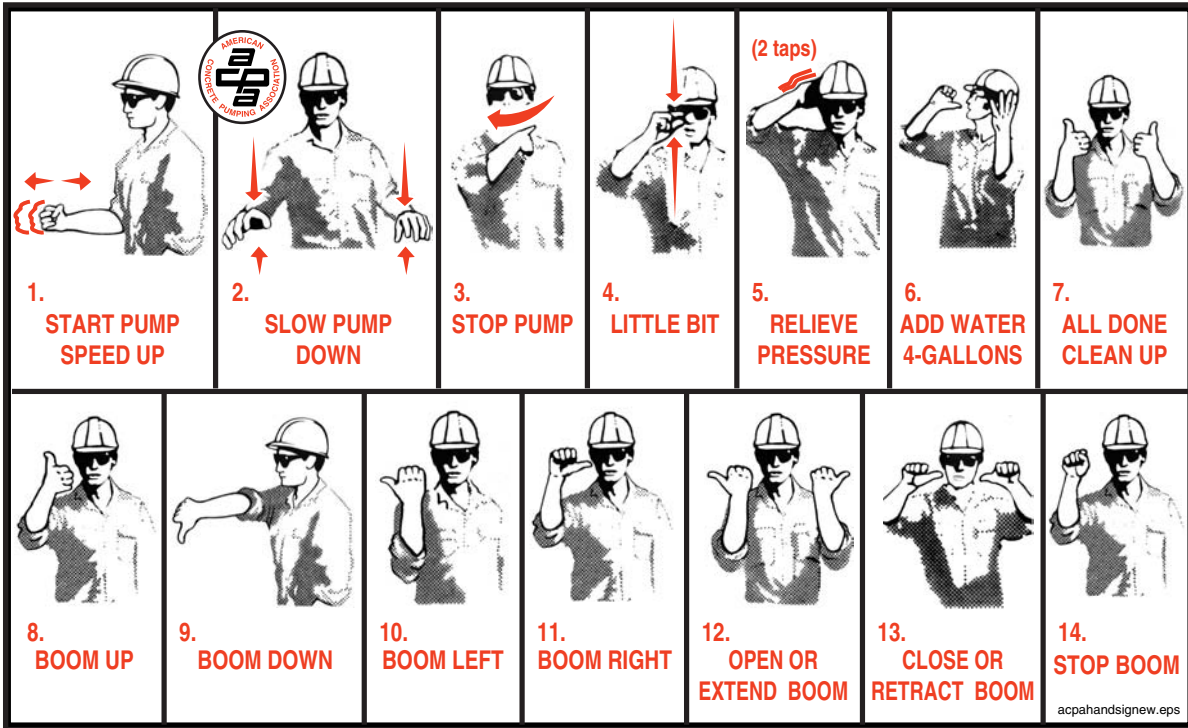
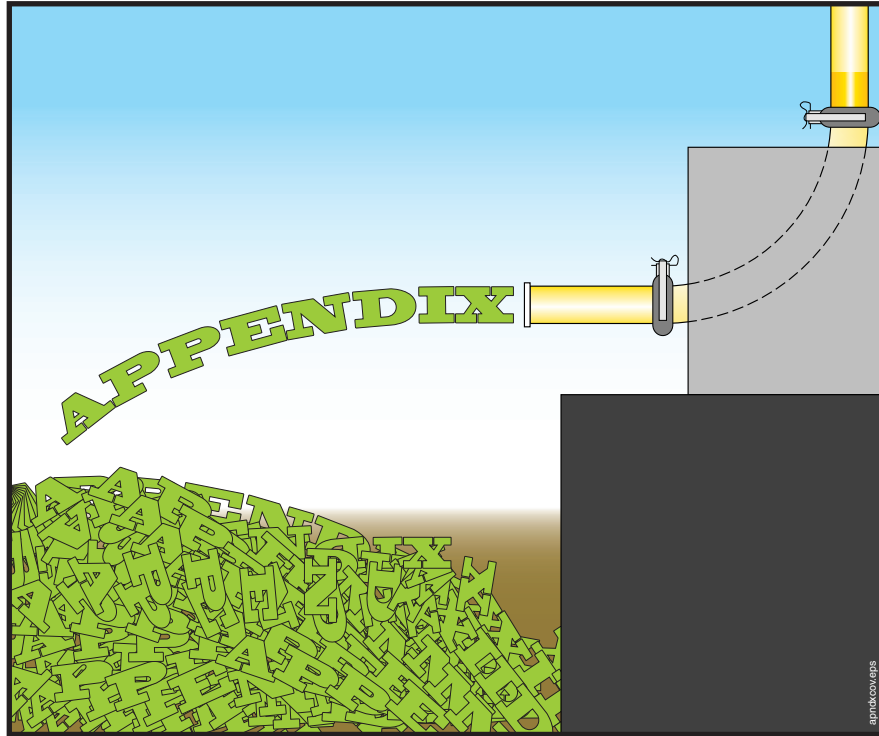

Figure 89
ACPA recommended hand signals



Appendix Table of Contents

VII.	Weld On Ends / Coupling Comparison	72
VIII.	Minimum Pipe Wall Thickness Chart	73
IX.	Glossary Of Terms	74
X.	Recommended Hand Signals	80
XI.	Bibliography	80

SAFETY MANUAL

VII. Weld On Ends / Coupling Comparison

Shown is a comparison among commonly used ends/couplings. No two ends shown can be joined without the use of an adapter pipe or a special adapter clamp. Clamps and pipe strength must also be considered when determining proper system requirements. The ratios shown in the text below represent the safety factor from burst : working

1. Male / female o-ring type couplings have the highest pressure rating of the ends commonly used for concrete pumping. They can withstand 4350 PSI @ a 2:1 safety factor. They are self aligning and waterproof when used with o-rings in good condition. Typically not used on booms because of their weight. Pipes equipped with this style coupling cannot be swapped end-for-end.

2. Heavy-Duty couplings are designed for pressures up to 2250 PSI @ 2:1. They have 20% more contact area than metric couplings, and a tapered face that draws the pipe sections together during assembly. Both the ends and clamps weigh more than metric style, and therefore should not be used on booms without consulting the manufacturer.

3. Metric couplings are designed for pressures up to 1400 PSI @ 2:1. They have 85% more contact area than grooved couplings. The face is flat and will not draw pipe together. Although they have a raised edge, they are not compatible with Heavy Duty couplings unless a special clamp or an adapter pipe is used to change from one style to the other. Metric connections are standard equipment on booms because of the weight savings compared with other styles.

4. Grooved couplings (lip height of 0.15" or less) are designed for pressures only up to 750 PSI @ 2:1. The recessed groove is hard to clean when changing pipe on a job. The weld-on end fails before the pipe because the groove is cut into the pipe thickness, making it the weakest spot. Grooved couplings are not recommended for concrete pumping applications.

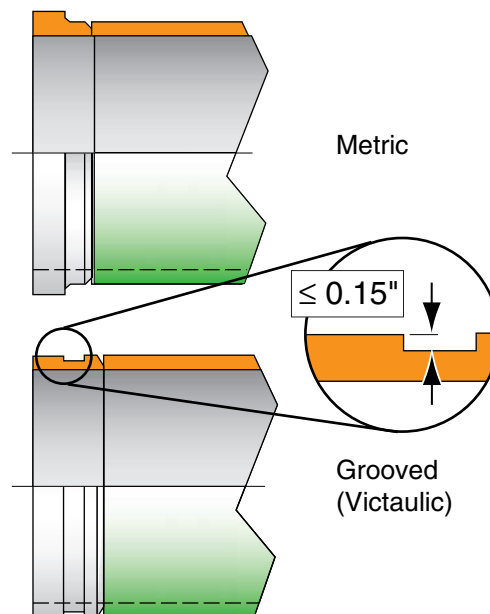
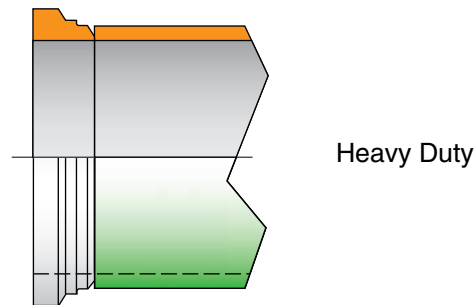
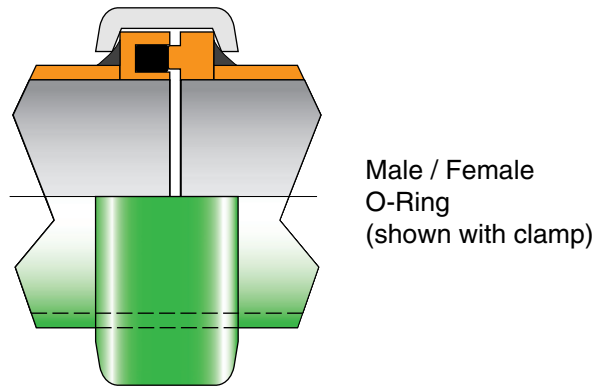

weldends4.eps

NOTE: All pressure ratings listed refer to 5 inch (125mm) diameters in like-new condition. Other pressures would apply to other sizes.

SAFETY MANUAL

VIII. Minimum Pipe Wall Thickness Chart

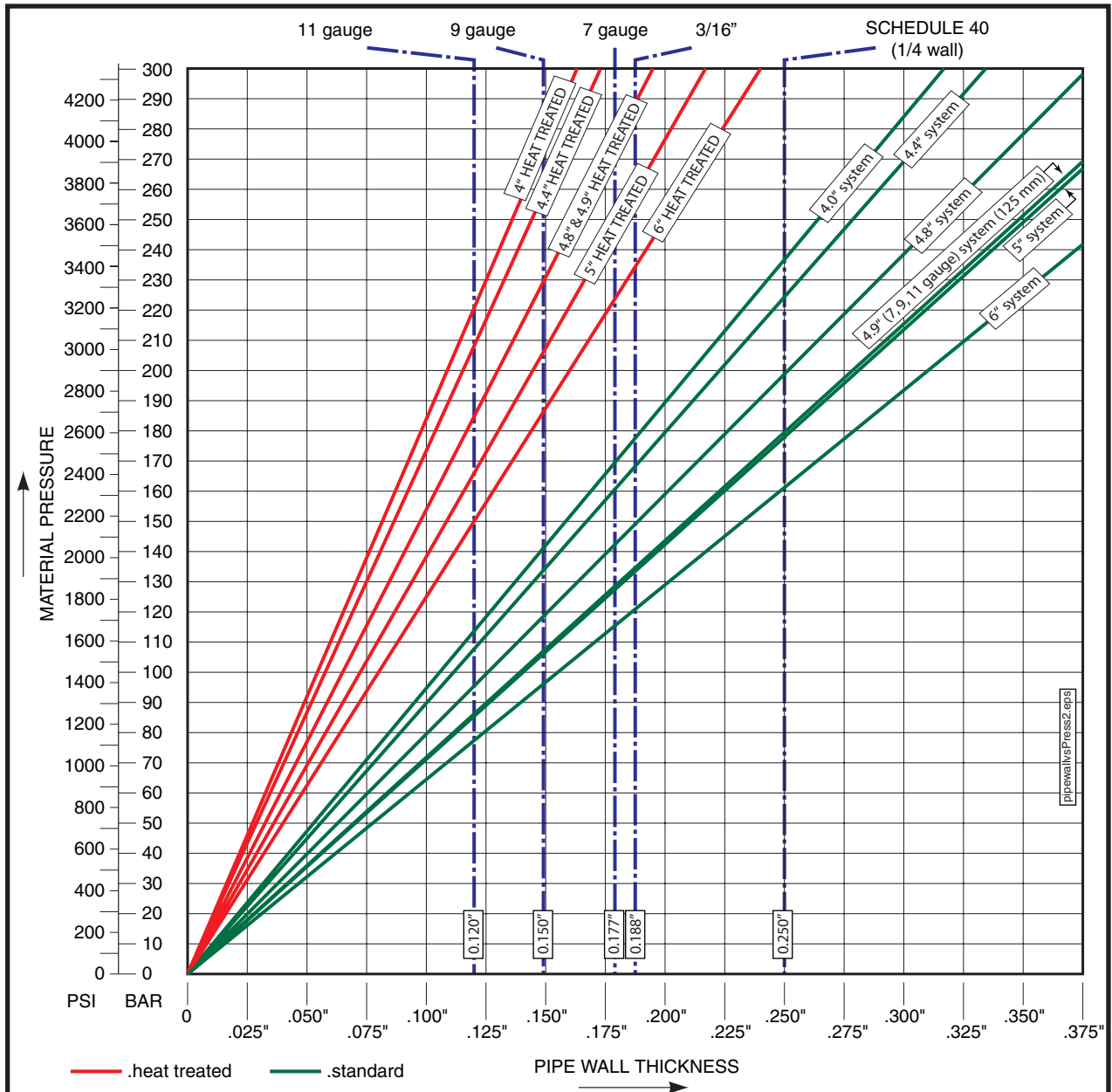

1. This chart assumes a safety factor of 2:1. Higher safety factors may be required in some circumstances.
2. Wear reduces wall thickness. Thickness must be checked on a regular basis.
3. Pressures may be limited even more by clamp style or pipe end used.
4. The chart is based on 62,000 PSI tensile strength. Heat-treated calculations are based on 120,000 PSI tensile strength.
5. The chart is for pressure calculations ONLY. There is no allowance for mechanical forces other than pressure, and thicker walls may be needed for mechanical strength because of support or restraint considerations.
6. The chart does not take into account metal fatigue caused by pressure cycles.

Note! This chart is intended as a guide for concrete pumping applications and is subject to the notes, assumptions, and conditions listed above. Any other use of this chart is not recommended.

This chart does not apply to double-wall pipe. Double wall pipe can be checked by inspecting the inside of the pipe. If the insert is intact, the pipe is okay. If the insert is worn through, the pipe must be replaced. Contact your pipe supplier for the pressure capacity of your double-wall pipe.

SAFETY MANUAL

IX. Glossary Of Terms

Accumulator

A hydraulic device that stores fluid power energy in much the same way that a battery stores electrical energy. Because an accumulator will store energy, it **MUST** be drained and depressurized before work begins on an accumulator equipped actuator or hydraulic system.

Agitator

A device that sits in the concrete hopper to keep concrete moving, preventing it from setting. It is typically a rotating shaft to which several paddles have been mounted. *See Also:* Hopper Grate

AWS D1.1

The code for structural welding with steel as defined by the American Welding Society. Sections 3, 5, and paragraph 9.25 of section 9 apply. *See Also:* Certified Welder and EN 287-1

Blanking Plate

Also known as a blanking plug or end cap. It's purpose is to prevent material from falling out of the delivery system (typically the end hose) when moving a boom with a full pipeline over personnel or property.

Blockage

Simply put, if the pump is pushing and concrete fails to come out at the point of discharge, it is called a blockage. Blockages can be removed with pump pressure, by rocking the pump between forward and reverse, or some other remedial measure. If the blockage can not be removed in such a manner, it's called a plug. *See Also:* Plug, Rock Jam. The causes of blockages are detailed in section 8.21 of this manual. In all cases, blockages create a hazard by causing high concrete pressure, combined with the sometimes uncoordinated efforts of untrained workmen to remedy the problem.

Bulk Density

The mass of a substance per volume. For example, one cubic foot of air weighs much less than one cubic foot of water. One cubic foot of lightweight concrete weighs less than one cubic foot of steel entrained concrete. We could say that steel entrained concrete has a higher bulk density than lightweight concrete. All calculations for the operation manuals and specifications of concrete pumps are based upon 150 pounds per cubic foot, which is the approximate mass of hard rock (normal) concrete.

Certified Operator

An operator that has been issued a certification card by the American Concrete Pumping Association. There are several classes of certification, each relating to a different category of pump. For an operator to become certified, he (she) must pass the written tests regarding operation, setup, and clean out for each category of pump, pass the safety rules test which is common to all certification categories, meet the experience requirements set forth for each category, and maintain a safe and clean driving record. The certification card only certifies that the operator has passed a written test administered by an A.C.P.A. certification tester and does not attest to their ability to operate a concrete pump. *See Also:* Qualified Person, Qualified Operator.

Certified Welder

As it relates to concrete pumping and this Safety Manual, a Certified Welder is a person that has applied for, taken and passed the American Welding Society (AWS) or the European Norm (EN) test for structural steel welding. Anyone welding on a concrete pump placing boom, outriggers, towers, etc. must be certified to AWS D1.1 sections 3, 5, and paragraph 9.25 of section 9 **and/or** EN287-1/PREN288-3.

SAFETY MANUAL

Concrete Delivery Hose

A flexible concrete hose that has two end couplings.

Concrete Pressure

The force per square area that is exerted on the concrete. The concrete pressure will always be a ratio in direct proportion to the hydraulic oil pressure on the concrete pump circuit. *See Also:* Maximum Pressure

Conductors

Materials that will conduct electricity. Copper, silver, aluminum, gold, steel, and water are considered GOOD conductors of electricity. Air, fiberglass, rubber, ceramics and glass are considered POOR conductors. All of these conductors have a resistance to the flow of electricity that can be measured in terms of ohms per linear foot. As voltage gets higher, more current flows through the same resistance. In the case of high voltage electric wires (8000 volts, for example) even the poor conductors will carry enough current through your body to ground that you could be killed. (As little as 35 milliamps can cause fibrillation of the heart.) Some conductors, like air, resist electricity very well, but if the voltage gets high enough, current will flow (lightning is a good example of this). *See Also:* Electrocutation

Decibels

One tenth of a bel. Abbreviated dB. It is a measurement of sound volume. As it applies to concrete pumps, it is a measurement of the sound pressure level one meter away from a noise source. O.S.H.A. has developed guidelines for time limits on exposure to sound at different volume levels. The chart can be found on page 36 of this manual.

Drive Engine

The primary source of power for a hydraulic system. Typically, the word “engine” denotes an internal combustion device, whereas the word “motor” denotes an electrical device.

Electrocutation

Made from the words “Electric” + “Execution.” It means death by electricity. *See Also:* Conductors

EN 287-1 / PREN 288-3

The code for structural welding with steel as defined by the European Norm. *See Also:* Certified Welder, AWS D1.1.

End Hose

A flexible concrete hose that has one end coupling.

Foreign Material

Material that was never intended to be pumped, which ends up in the concrete hopper. Examples of foreign material include small animals, hammers, ready mix truck fins, unmixed clumps of cement, hardened concrete that breaks away from ready mix truck fins, and soda pop cans. These items could create a blockage if pumped.

Go Devil

A plug made from a rubber composite, usually with several fins that expand to seal when pressure is applied. They are intended to be inserted in a steel delivery pipeline and pushed with water or compressed air for the purpose of cleaning the pipe. *See Also:* Sponge Ball

Guide

An assistant brought in to help in backing up a truck or trailer, or to help in other circumstances where the driver cannot see enough to assure safety. *See Also:* Spotter

SAFETY MANUAL

High Voltage

For the purposes of this manual, anything over 24 volts is to be considered high voltage. In the U.S., electrically driven concrete pumps normally operate the motors at 480 volts AC (high voltage) and the controls at 24 volt DC (low voltage). When dealing with electric wires in residential or industrial areas the voltage will be approx. 8000 volts to ground, or 13,800 volts from phase to phase (distribution voltage). When dealing with electric wires that are mounted on steel towers high above the ground, the voltage will range from 100,000 to 1,000,000 volts (transmission voltage).

Hopper Grate

A meshwork placed over the concrete hopper, typically made from steel bars. It serves the functions of keeping human body parts away from the agitator (when left in its proper position) and keeping large foreign objects from falling into the hopper, which could cause blockages if they were pumped.

Jacking the Outriggers

Adjustment of the outriggers in the vertical direction. With boom mounted concrete pumps you should strive to make the adjustments so that the unit sits within 3° of level.

Licensed Electrician

A qualified electrician licensed by the state, county or municipality where the connections are to be made. In some locations electricians are not required to be licensed, and in these cases the work should still be carried out by competent professionals. Under no circumstances should high voltage connections be made by a concrete pump operator or related personnel.

Maintenance

All procedures for service, inspection, and repair of concrete pumps and related equipment and devices. Maintenance and inspection are methods of *maintaining* the desired state of the equipment. Repair is the method of *restoring* the desired state of the equipment.

Maximum Pressure

When talking about a hydraulic system, maximum pressure refers to the highest pressure that can be achieved with the settings of the circuit relief valves. When discussing concrete output, maximum pressure refers to the pressure that will be developed if the hydraulic system pressure reaches the relief valve setting. Concrete pressure is the force at which the differential cylinders are moving, divided by the cross sectional area of the concrete cylinder. Maximum concrete pressure, then, is developed when the differential cylinders are moving with maximum force, which is determined by the hydraulic system relief valve setting. *See Also:* Concrete Pressure.

Minimum Safety Distance

In this manual, the term “minimum safety distance” refers to the closest distance that you are allowed to approach an object, electrical wires, etc. and still leave room for errors in human judgement or machine malfunction. With electrical wires in the U.S., this distance is 17 feet, as recommended by the American Concrete Pumping Association. This distance may have other values in different countries (Canada specifies 7 meters). It is up to the operator to know the value for the place of operation.

Operational Area

The area around a working piece of equipment or point of discharge where hazards can be encountered due to the nature of the machinery or process in use.

O.S.H.A.

Occupational Safety and Health Administration. A branch of the United States federal government that deals with job safety. They establish and enforce safety regulations for industry and

SAFETY MANUAL

business. Among the areas over which they have authority are construction job sites and work shops.

Personal Protective Equipment (P.P.E.)

Things you can wear to protect yourself from potential dangers in a concrete placing environment. Examples are:

- Snug fitting work clothes
- Steel toed work boots
- Lime resistant gloves
- Safety glasses
- Ear muffs or ear plugs
- Rubber boots when you have to stand in concrete
- Hard hat
- Breathing mask when working with cement dust

Plug

A plug is a blockage that cannot be removed with the pump pressure, or by other remedial measures. A plug must be removed manually. *See Also:* Blockage.

Point of Discharge

Also known as the point of placement. The location of concrete expulsion from a delivery system. This can be the point of placement (the actual form that is being filled with concrete) or the clean out area after completion of the job.

Pour

Used by the concrete pumping industry and in this manual as a noun. It is the specific job for the pump during any given time period. (e.g. “We’ll grab lunch right after the pour.”)

Qualified Person

As used in this Safety Manual, a *qualified person* is defined as: a person who, by possession of a recognized degree of certificate of professional standing, or who by extensive knowledge, training, and experience, has successfully demonstrated the ability to solve or resolve problems relating to the subject matter and work. Other qualified persons may include master mechanics and after-sales service technicians of the manufacturer. *See Also:* Certified Operator

Qualified Operator

Operators shall be considered qualified when they have completed a program of training and supervised operation of concrete pumps and have passed a practical operating examination of their ability to operate a specific model and type of equipment as well as their understanding of the controls and operating procedures. Furthermore, the operator must meet the knowledge and physical requirement sections of the concrete pumping safety standard.

Qualified Personnel

A generic term used to describe a person who is qualified in the area of application. For example, having your boom repairs inspected by “qualified personnel” before use would refer to inspection by a certified welder or certified welding inspector. Having repairs to your hydraulic system done by “qualified personnel” would refer to repairs made by qualified workshop personnel.

Qualified Workshop Personnel

An individual who:

- has reached the age of 18 years,
- is physically and mentally capable,
- has been trained in proper repair, maintenance, and inspection procedures plus the pertinent safety rules for concrete pumps and related equipment,
- has demonstrated their capabilities to their company in regards to the above mentioned

SAFETY MANUAL

- procedures and rules, and
- can be expected to perform these duties, as assigned, in a reliable manner.

Rock Jam

A specific type of blockage caused when the cement and fines of the concrete are not present in sufficient quantity to fully coat the larger aggregates and the walls of the delivery system. In these cases, the rock (larger aggregates of the mix) will form a wedge inside of the pipe. Resistance to movement then becomes overpowering and the concrete stops. *See Also:* Blockage.

Separate Pipeline

A pipeline that is laid between the concrete pump and the point of discharge, other than the placing boom pipeline.

Shutoff Valve

In hydraulics: a valve with the ability to stop the flow or pressure of hydraulic oil. It must be able to withstand the maximum pressure of the hydraulic circuit that it controls. In concrete: A manually or hydraulically operated valve that will prevent the flow of concrete in either direction. The shutoff valve must be able to withstand the maximum pressure on the concrete of which the pump is capable of exerting.

Soil Pressure

The force per square area that is exerted on the ground by the outrigger legs. The amount of pressure that the soil will support varies with the composition and compaction of the soil. To make a determination on the stability of the soil, see the chart on page 22 of this manual.

Sponge Ball

A medium to hard sponge formed into a sphere and used to clean the inside of delivery pipelines. *See Also:* Go Devil

Spotter

A spotter is a person who stands at a vantage point where he (she) can see both the point of discharge and the operator of the pump. The spotter would then direct the operator to operate the unit as required by the job circumstances with two-way radios or hand signals. A spotter can be anyone who is familiar with the safety rules for the pump and workers and is equipped with a radio or knows the appropriate hand signals. A spotter is needed whenever the operator cannot safely see the point of placement or the distance between the unit and an unsafe area. *See Also:* Guide

Sucking Back

The act of putting the concrete pump into the reverse mode for any of several reasons.

Thrust Block

Also known as a “dead man”. This is a large block of poured concrete, usually with one or more sweep elbows cast inside, placed at the bottom of a vertical run for the purpose of supporting the weight of the vertical run and for lateral stabilization of the pipeline. It stabilizes and supports the vertical run by virtue of its enormous mass (normally one cubic yard or larger).

Towing Vehicle

In this manual, *Towing Vehicle* applies only to vehicles that tow trailer mounted concrete pumps. It is the vehicle that you will use to tow the trailer on the road, on the job site, or in the yard. See the safety rules regarding this subject on page 10 of this Safety Manual.

Transport Position

This relates to the position of the boom when you will be driving the unit. The travel position of the boom is the position of the boom when it is completely folded and lowered into the rests.

SAFETY MANUAL

Unauthorized

Without authority, without permission. Examples: Unauthorized operation of the boom could be operation by a passer-by, unauthorized repairs to the boom could be repairs designed without the manufacturer's knowledge.

Unintentional Movement

Movement of the pump, boom or related equipment without a specific intentional command by the operator. An example of an unintentional movement would be if an operator fell while walking with the remote control box and accidentally hit a joystick, causing a boom movement.

Vertical Run

Sections of concrete delivery pipeline that are running in an up (or down) direction. Vertical runs have very specific procedures and rules for installation, support, cleaning, and inspection. Concrete pumping personnel should, therefore, have specific training in these procedures and rules before attempting to use them in a job setting.

Water Jet

The actual stream of water that comes out of the end of a water hose or pressure washer. This is the only part of the water system that needs to go into the hopper, concrete valve, or water box for cleaning.

SAFETY MANUAL

X. Recommended Hand Signals

The American Concrete Pumping Association (ACPA) recommends using the following hand signals as standard procedure.

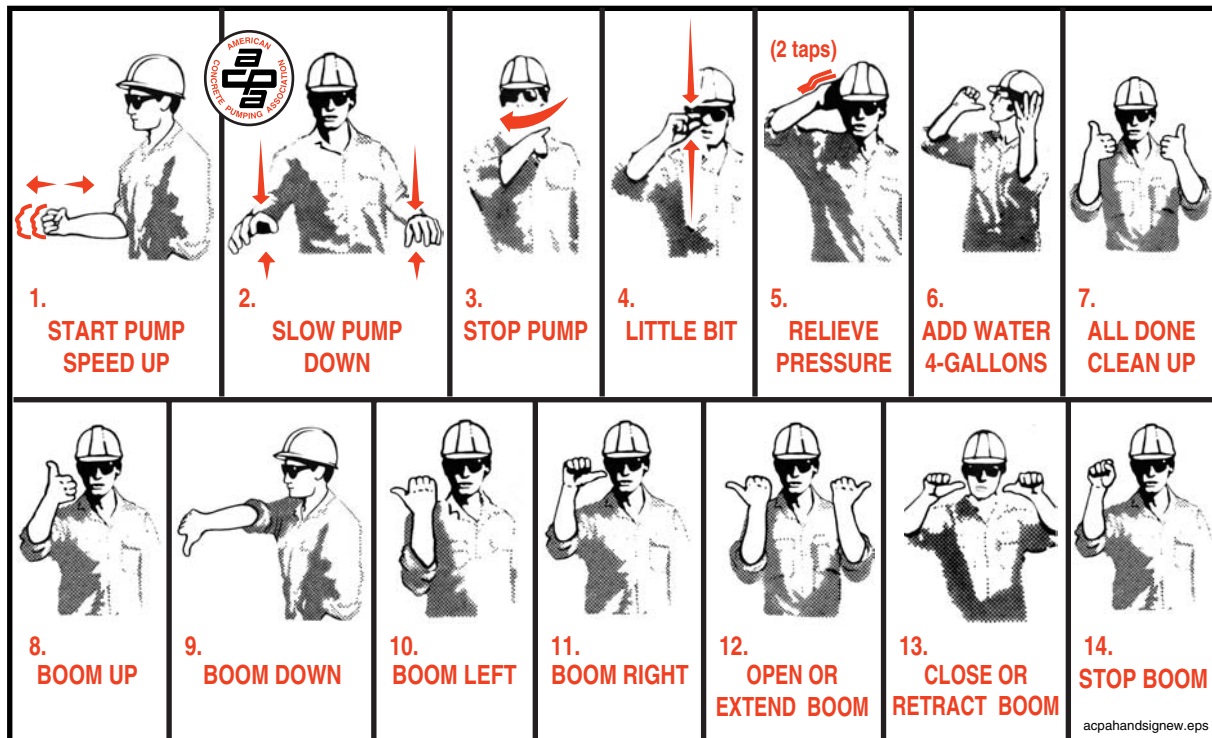

XI. Bibliography

Further information regarding concrete pumping is available from the sources listed below. Information for this book was gathered from several different sources, including the following books:

PUMPING CONCRETE AND CONCRETE PUMPS © F. W. Schwing, GmbH

CONCRETE PUMP OPERATOR'S GUIDE TO SAFETY © British Concrete Pumping Association

The MANUAL and ADVISORY SAFETY CODE of PRACTICE for CONCRETE PUMPING © British Concrete Pumping Association

SAFETY STANDARD FOR CONCRETE PUMPS, PLACING BOOMS, AND DELIVERY SYSTEM by the Concrete Pump Manufacturers Bureau

Additional technical information and/or graphic were supplied by:

Construction Forms, Inc.

The American Concrete Pumping Association

Some cartoons were scanned from the book CONCRETE PUMP OPERATOR'S GUIDE TO SAFETY © British Concrete Pumping Association. Used by Permission.

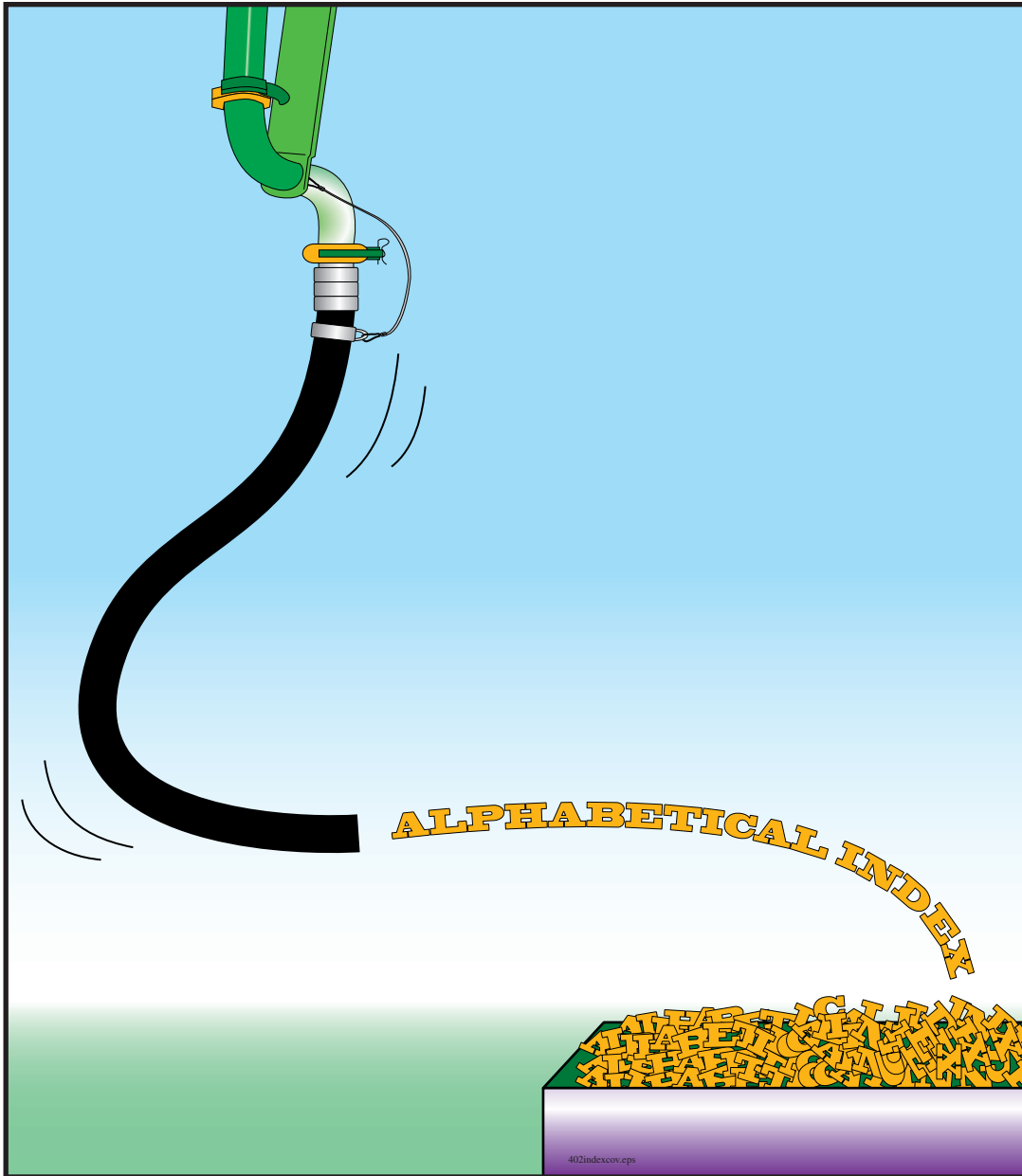

Alphabetical Index

Numerics

- 1 to 1 rule23
- 3 point rule7, 56

A

- accidents
 - causes of5, 12, 27, 44
- accumulator
 - changing max. pressure settings53
 - defined74
 - maintenance55
- ACPA recommended hand signals70, 80
- agitator, defined74
- air in delivery system38, 60, 65
- air, compressed
 - See* cleaning out, with compressed air
- alcohol, use of when operating4
- apparel
 - appropriate2, 32
 - inappropriate2
- AWS D1.1, defined74

B

- ball catcher types31
- blanking plate, defined74
- blockage
 - before opening pipeline39, 40
 - clearing with compressed air ...40, 50, 66
 - concrete segregation39
 - defined74
 - foreign matter38, 59
 - inadequate pump38
 - inexperienced placing crew39
 - kinked hose40
 - operator error38
 - pipe deficiencies38
 - procedure to remove39
 - safe removal of39, 40, 61, 66
 - setting of concrete38
 - unpumpable mix38
- blow out head
 - See* clean out accessories, blow out head
- blowing out
 - See* cleaning out, with compressed air
- boom
 - See* placing boom

- boom, watching65
- bulk density, defined74

C

- catcher, types of31
- caution, defined2
- certified operator, defined74
- certified welder, defined74
- checks
 - pre-dispatch5, 6
- children, dangers to26, 30
- clamps
 - for dissimilar ends53
 - pre-dispatch5
 - re-assembly when removing pipes67
- clean out accessories
 - blow out head5, 30, 47
 - pre-dispatch5
 - use30, 47, 50
 - catcher46, 47
 - pre-dispatch5
 - size5, 30
 - types31
 - use30, 47
 - compressed air
 - attachments4, 30, 44, 47
 - hose5, 30
 - go devil
 - defined75
 - size47
 - use47, 50
 - sponge ball5, 30, 47
 - defined78
 - size5, 30, 47
 - use47, 50
- cleaning out
 - hopper45
 - personal protective equipment44
 - the water box45, 46
 - position of the boom45
 - water box46
 - with compressed air30, 44, 47
 - blockage66
 - clean out attachments30
 - communications50
 - discharge area49

experts	47	certified operator	74
near personnel	47, 50	certified welder	74
need for 2 people	47	concrete delivery hose	18, 75
outlet positioning	47	concrete pressure	75
relieving air pressure	44	conductors	75
shutoff valve	48	danger	2
through hose	44, 47, 48	decibel	75
through short pipe	44, 47, 48	drive engine	75
trapped air	49	electrocution	75
vertical pipelines	30, 49, 50	EN 287-1 / PREN 288-3	75
when to stop	48	end hose	18, 75
with water	46	expert	77
clothes, appropriate	2	foreign material	75
compressed air		go devil	75
<i>See</i> cleaning out, with compressed air		guide	75
concrete		high voltage	76
bulk density maximum	38	hopper grate	76
unpumpable mix	38	jacking the outriggers	76
concrete delivery hose, defined	18, 75	licensed electrician	76
concrete pressure, defined	75	maintenance	76
concrete valve		maximum pressure	76
danger	41, 42, 62	minimum safety distance	76
conductors, defined	75	O.S.H.A.	76
couplings	53	operational area	76
comparison	72	personal protective equipment	77
grooved type	72	point of discharge	77
Heavy-Duty type	72	pour	77
male/female o-ring type	72	qualified operator	32
metric type	72	qualified personnel	77
Victaulic type	72	qualified workshop personnel	77
D		rock jam	78
danger, defined	2	safety alert symbol	2
dead man,		separate pipeline	78
<i>See</i> thrust block		shutoff valve	78
decals		signal word	2
safety	51	soil pressure	78
decibel, defined	75	sponge ball	78
definition		spotter	78
accumulator	74	sucking back	78
agitator	74	thrust block	78
AWS D1.1	74	towing vehicle	78
blanking plate	74	transport position	78
blockage	74	unauthorized	79
bulk density	74	unintentional movement	79
caution	2	vertical run	79

- warning2
- water jet79
- delivery system
 - air in line38, 60, 65
 - attaching to boom25
 - cleaning with compressed air ...30, 44, 47
 - cleaning with water46
 - damaged28
 - gaskets
 - pre-dispatch5
 - reassembly when removing pipe67
 - handling61, 68
 - hose
 - inspection4
 - kinked40
 - pre-dispatch5
 - inspection on the job28
 - maximum pressure4, 27, 53
 - minimum wall thickness ..4, 26, 27, 28, 52
 - pipe
 - end comparison72
 - ends53
 - inspection4
 - pre-dispatch5
 - wall thickness chart73
 - repair of bad hose and pipe53
 - sizing diameter28
 - suspended sections28
 - tapping for ball location44
 - tip hose
 - maximum length17
 - usable condition26, 27
 - vertical runs28
 - blowing out50
 - shutoff valve30, 50
 - thrust block29
- dirt
 - removal16
 - support capacity *See* soil, support capacity
- drive engine, defined75
- driving
 - cautions10
 - safety devices7, 10, 11
 - selecting route8
 - stopping distance10
- windshield and mirrors7
 - with concrete in the hopper9
 - with PTO engaged9
- drugs4
- E**
 - electrical components53
 - cautions53
 - electrical wires
 - booming over13
 - contact with an energized unit58, 64
 - depth perception of14, 34
 - driving dangers near8
 - minimum distance from13, 33, 54
 - setup dangers14, 16
 - electrically driven units
 - disconnect box27
 - maintenance55
 - power supply responsibility27
 - electrocution, defined75
 - emergency stop41, 57
 - EN 287-1 / PREN 288-3
 - defined75
 - end hose, defined18, 75
 - expert, defined77
- F**
 - falling, prevention9, 37, 54, 60, 69
 - foreign material, defined75
 - fuel, dangers of36
- G**
 - gasoline and diesel fuel
 - as cleaning solvents55
 - glossary of terms74
 - go devil5
 - catcher5, 31
 - defined75
 - size47
 - use50
 - grate
 - water box41
 - guards, removal of
 - for inspection51
 - for servicing53
 - guide
 - defined75

H

- hand signals 25, 29, 42
 - ACPA recommended 70, 80
 - who should give 70
- height
 - knowledge of 8
- high voltage
 - defined 76
- high-voltage wires, *See* electrical wires
- hopper
 - danger around 41, 42, 45, 59, 62
- hopper grate, defined 76
- hose
 - holding correctly 67
 - hugging 67
 - inspection 4
 - kinked 40
 - maximum pressure 4
 - pre-dispatch 5
- hoseman 67
 - walking 67

I

- ice
 - removal 16
- inspection
 - after structural repair 56
 - boom tiedown devices 51
 - concrete pump circuits 51
 - delivery system 52
 - placing boom 51
 - daily 51
 - keeping records 51
 - reporting problems 51
 - safety devices 51
 - service bulletins 51

J

- jacking the outriggers, defined 76

K

- kinked hose, *See* blockages

L

- laborers
 - alone at the pump 41, 57
 - assigned to the pump 41, 57

- e-stop location knowledge 41, 57
- handling delivery system 61, 68
 - notifying operator 59
 - personal protective equipment 57
- licensed electrician, defined 76
- lights 8
- lockout, tagout 42, 55
- loose items
 - securing for travel 7, 8

M

- maintenance
 - changing maximum pressure settings 53
 - components, damaged 53
 - cranes and hoists, use of 54
 - defined 76
 - extending placing boom 54
 - for safety 52
 - gas or diesel as cleaning solvent 55
 - hidden areas 55
 - inspection following structural repair 56
 - of electrically driven units 55
 - of spring- or gas-loaded devices 55
 - oil, hot 54
 - operation of boom 54
 - removal of safety devices 53
- repairs
 - by qualified personnel 53
 - of hydraulic hose and pipe 53
 - of pressurized hydraulics 55
- repairs, incorrect 54
- safety of workers 55, 56
- structural modifications, unauthorized 53
- tools, correct 56
- welding 53
- maximum pressure, defined 76
- medications, cautions 4
- minimum safety distance, defined 76

N

- noise exposure chart 36

O

- O.S.H.A. 12, 27
 - defined 76
 - noise exposure chart 36

- obstructions
 - safe distance from16
 - oil
 - removal16
 - spills52
 - oilers, *See* laborers
 - 1 to 1 rule23
 - operation
 - danger to children26, 30
 - discharge point25, 29, 42
 - for servicing54
 - noise36
 - noise exposure chart36
 - personal protective equipment32
 - problems with equipment39, 51
 - security26
 - unfamiliar machines7
 - warnings4
 - operation manual4, 7, 18, 19, 51, 52, 53, 54
 - operational area
 - defined76
 - operator
 - certification74
 - qualified, defined32
 - outrigger jacking, defined76
 - outriggers
 - close any hydraulic valves24
 - cribbing24
 - intermediate positions22
 - leveling the unit22
 - minimum distance from edge23
 - pinning7
 - soil support22
- P**
- personal problems, at work4
 - personal protective equipment
 - defined77
 - Personal Protective Equipment (P.P.E.) 2, 7, 32, 39,44, 57
 - for laborers57
 - for placing crew65
 - securing for travel7
 - pipe
 - ends53
 - inspection4
 - opening when pressurized 66
 - pre-dispatch 5
 - pressurized 66
 - wall thickness chart 73
 - weld on ends 72
 - pipewall thickness chart 73
 - placing boom
 - adding extensions 17
 - as hoist 54
 - attaching to separate pipeline 25
 - booming over wires 13
 - depth perception dangers 14, 34
 - discharge point 25, 29, 42
 - extending for maintenance 54
 - extensions 17
 - inspection 51
 - max. bulk density of concrete 38
 - max. hanging weight 18
 - max. length of endhose 17
 - max. weight of pipeline 53
 - travel position 9, 44
 - unintentional movement 41
 - placing crew
 - dangerous areas 66
 - dealing with blockages 61, 66
 - handling hose and system 66, 69
 - hazards
 - compressed air in pipeline 66
 - crushing 69
 - falling 37, 54, 60, 69
 - hose kinking 68
 - hoses 68
 - pressurized pipes 69
 - personal protective equipment 65
 - safety rules 64
 - point of discharge, defined 77
 - pour, defined 77
- Q**
- qualified operator, defined 77
 - qualified personnel, defined 77
 - qualified workshop personnel, defined 77
- R**
- ready mix truck
 - backing 33, 58

driver	
cleaning out in the hopper	59
what to teach them	41
when to begin dumping	59
foreign material from	59
safe approach	20
signalling the driver	33, 58
refueling	36
remote control	
plugging and unplugging	41
rock jam, defined	78
S	
safety alert symbol, defined	2
separate pipeline, defined	78
service bulletins	51
setup	
ready mix truck approach	20, 27
traffic	20, 27
unsafe	12, 27
shutoff valve	
pressure requirements	49
shutoff valve, defined	78
signal word, defined	2
sleep, importance of	2
snow	
removal	16
soil	
support capacity	22
soil pressure, defined	78
sponge ball	
catcher	31
defined	78
size	47
use	50
spotter	64
spotter, defined	78
sucking back, defined	78
symbols	
caution	2
danger	2
warning	2
T	
3 point rule	7, 56
thrust block, defined	78
tie down straps	8
tipping	
danger of	10, 22, 23, 24
towing	
backing up	11
knowledge of the laws	11
loss of control	11
stopping distance	11
trailer mounted pumps	10, 11
truck mounted pumps	10
towing vehicle, defined	78
transport position, defined	78
U	
ultrasonic thickness tester	26, 52
unauthorized, defined	79
unintentional movement, defined	79
V	
vertical pipeline	
<i>See</i> delivery system, vertical runs	
vertical run, defined	79
Victaulic, <i>See</i> delivery system, pipe ends, grooved	
W	
walking with end hose	
backwards	67
correctly	67
warning, defined	2
watching the boom	65
water box	
checking while pumping	41
danger	41, 42, 45, 46, 62
water jet, defined	79
weather conditions	
considerations	6
lightning	25
maximum wind speed	25
weight	
knowledge of	8
knowledge responsibility	9
welding	
current arcing damage	53
minimum certification rating	53

- on electrical components53
- specification74, 75
- wheel chocks16
- wires, using a spotter64
- workers
 - alone at the pump41, 57
 - assigned to the pump41, 57
 - e-stop location knowledge41, 57

