

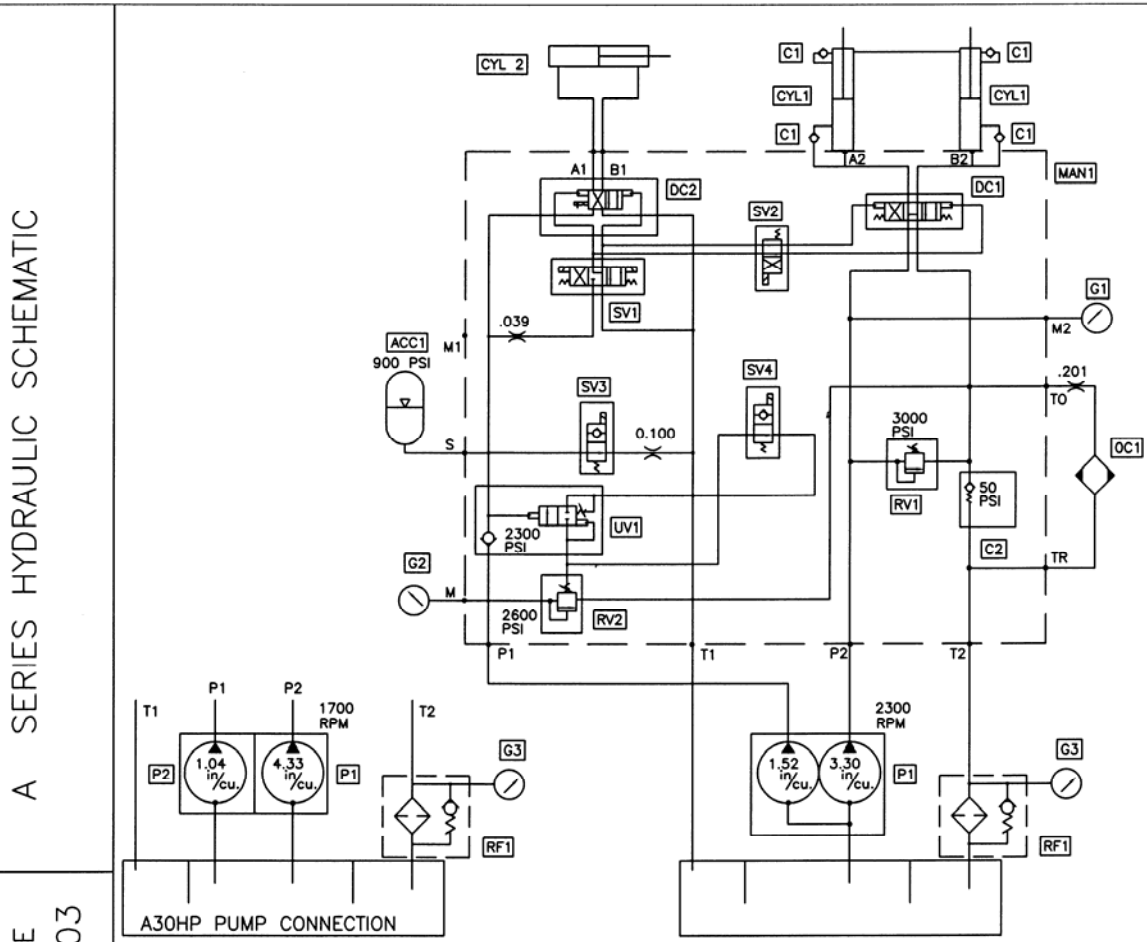

# TRAILER MOUNTED PUMP MODEL A40 HYDRAULIC COMPONENTS & SCHEMATIC

SCMTC

PAGE 01



A SERIES HYDRAULIC SCHEMATIC

DATE  
4/8/03

REV. C

PART NO.  
BW10041



CODE	DESCRIPTION	PART NO.	QTY.
P1	Main Pump, Parts, Group 40		1
P2	Gear Pump, Parts, Group 40		1
CYL1	Hydraulic Drive Cylinder, Parts Group 60		
CYL2	Hydraulic Shift Cylinder, Parts Group 60	BW10125	1
MAN1	Manifold Drive & Swing Cylinder Circuit	BW10325	1
DC1	Directional Cartridge Valve, Main Cycling	BW10181	1
DC2	Directional Cartridge Valve, S Tube Shifting	BW10182	1
SV1	Solenoid Valve Pilot	85691	1
	Coil For SV1	85692	2
SV2	Solenoid Valve Pilot	BW10183	1
SV3/SV4	Solenoid Valve 2 Way	BW10185	2
RV1	Relief Valve Cartridge	BW10326	1
RV2	Relief Valve Cartridge	85703	1
UV1	Unloading Valve Cartridge	85704	1
ACC1	Accumulator	BW10184	1
C1	Check Valve	78961	4
C2	Check Valve	BW10327	1
G1	Pressure Gauge 6000 psi	74562	1
G2	Pressure Gauge 3000 psi	70366	1
G3	Pressure Gauge Return	85575	1
OC1	Oil Cooler		1
RF1	Return Filter	BW10027	1
	Return Filter Element	BW10106	1

REVISION:



# TRAILER MOUNTED PUMP MODEL A40 ELECTRICAL SCHEMATIC (1 OF 4)

SCMTC

PAGE 02A

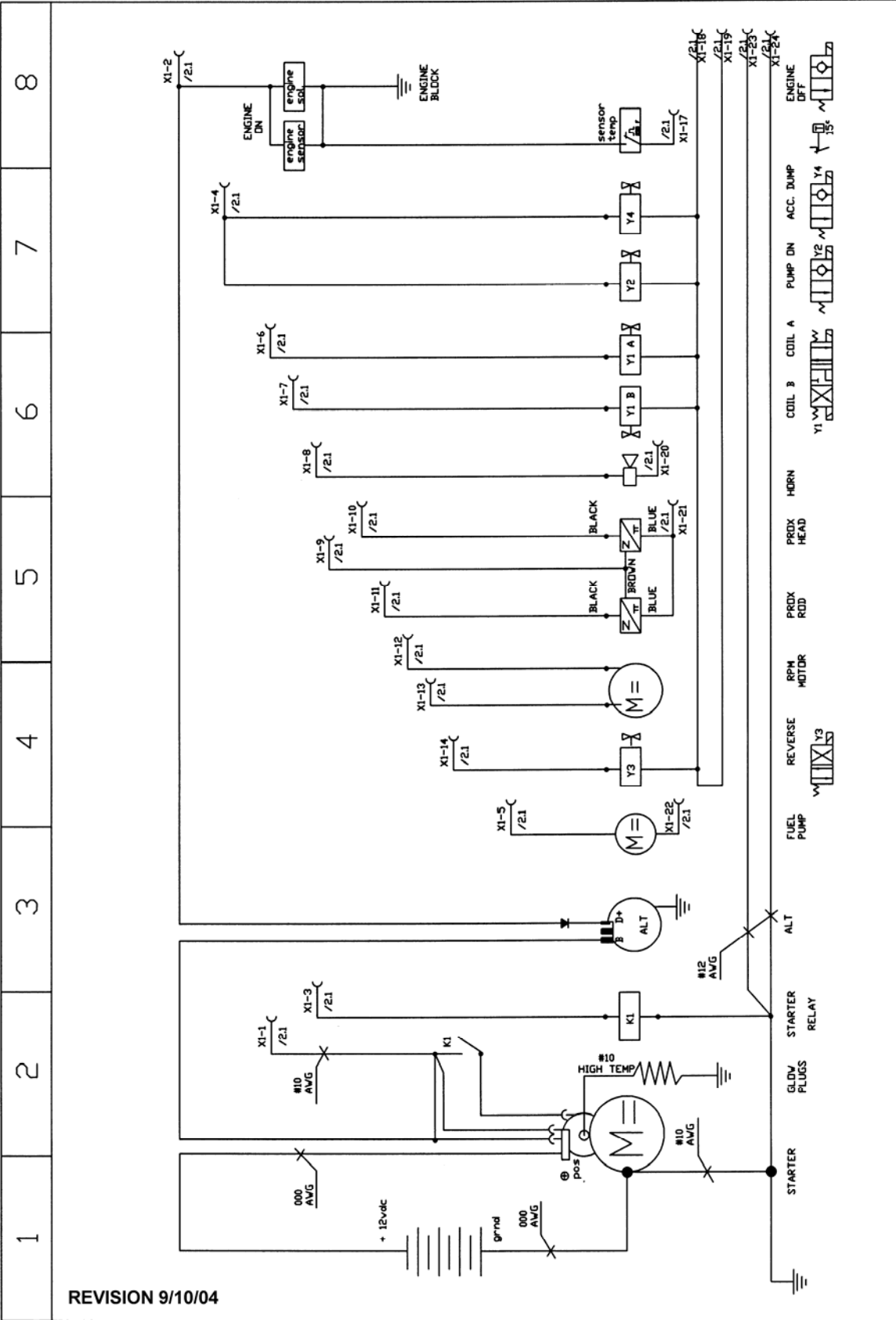
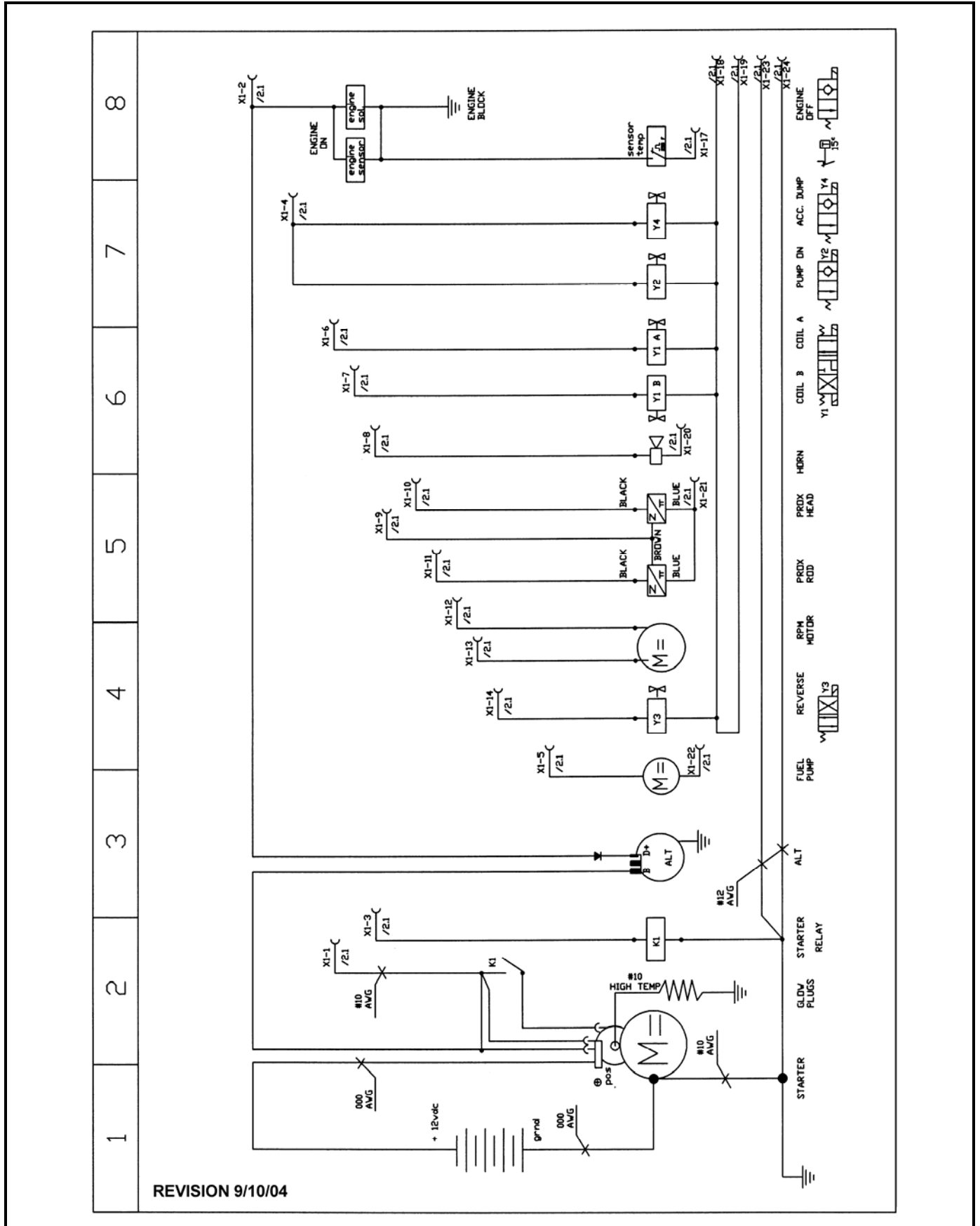

REVISION 9/10/04

REVISION:



# TRAILER MOUNTED PUMP MODEL A40 ELECTRICAL SCHEMATIC (2 OF 4)

SCMTC

PAGE 02B

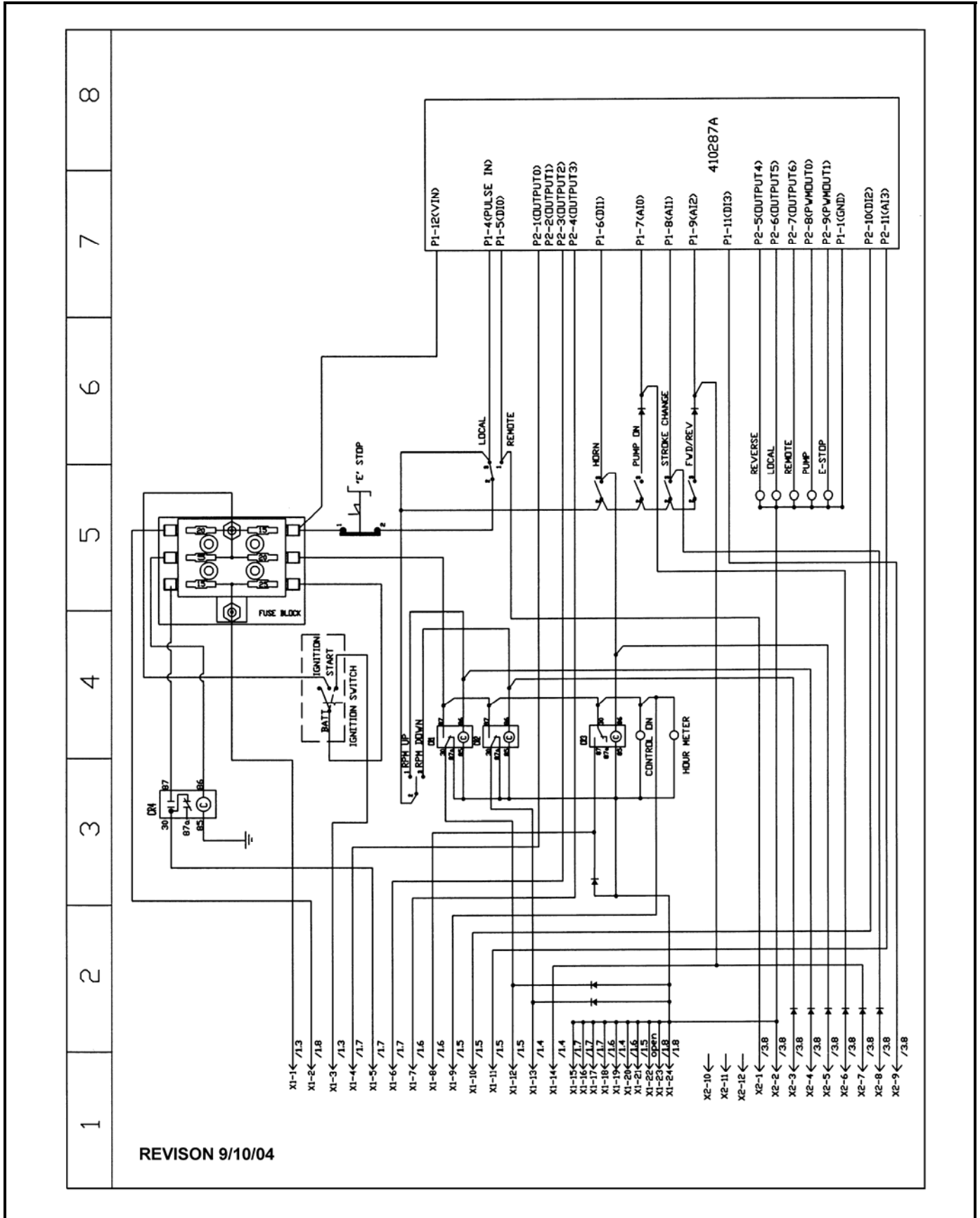

REVISION:



# TRAILER MOUNTED PUMP MODEL A40 ELECTRICAL SCHEMATIC (3 OF 4)

SCMTC

PAGE 02C

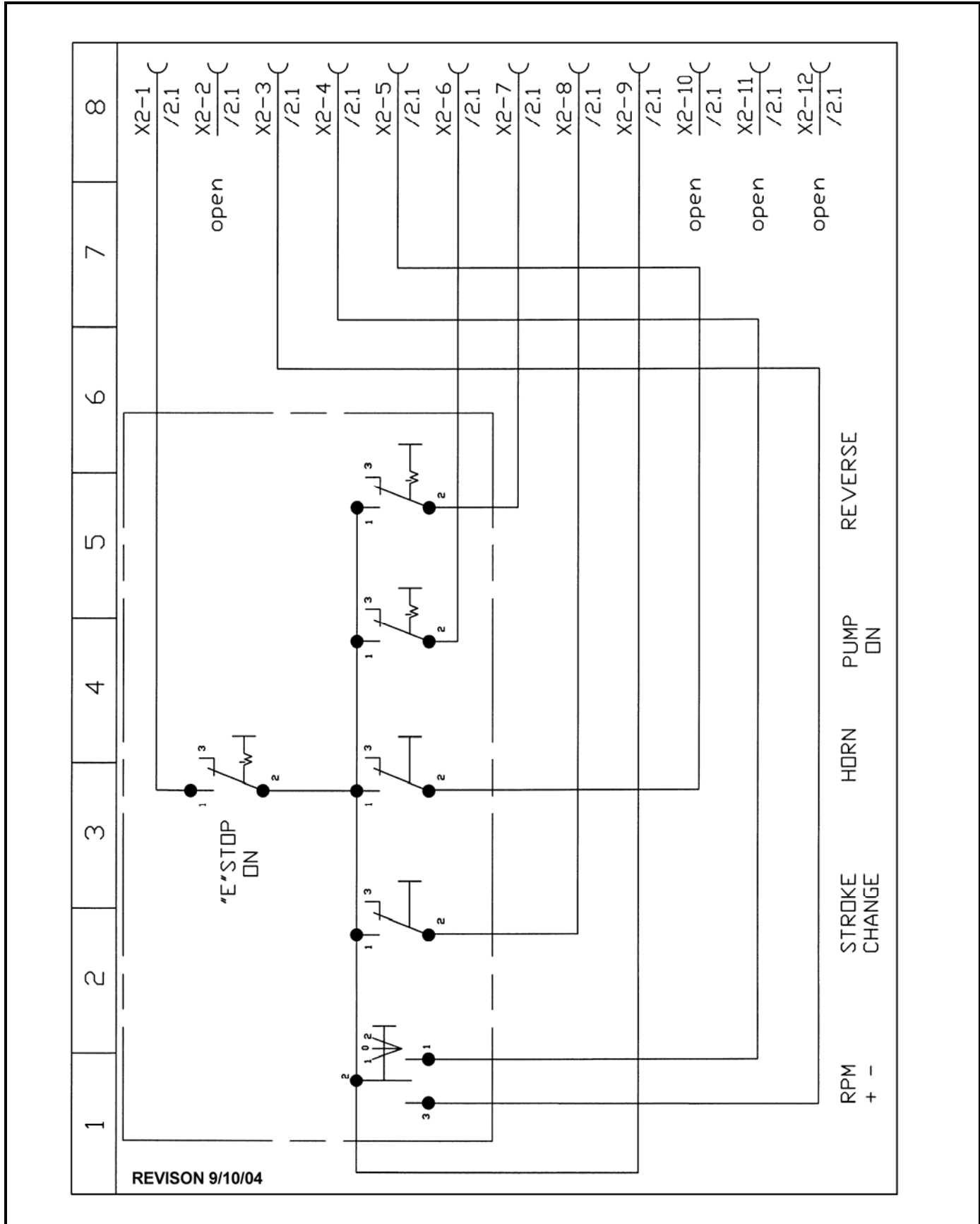

REVISION:





# TRAILER MOUNTED PUMP MODEL A40 ELECTRICAL SCHEMATIC (4 OF 4)

SCMTC

PAGE 02D

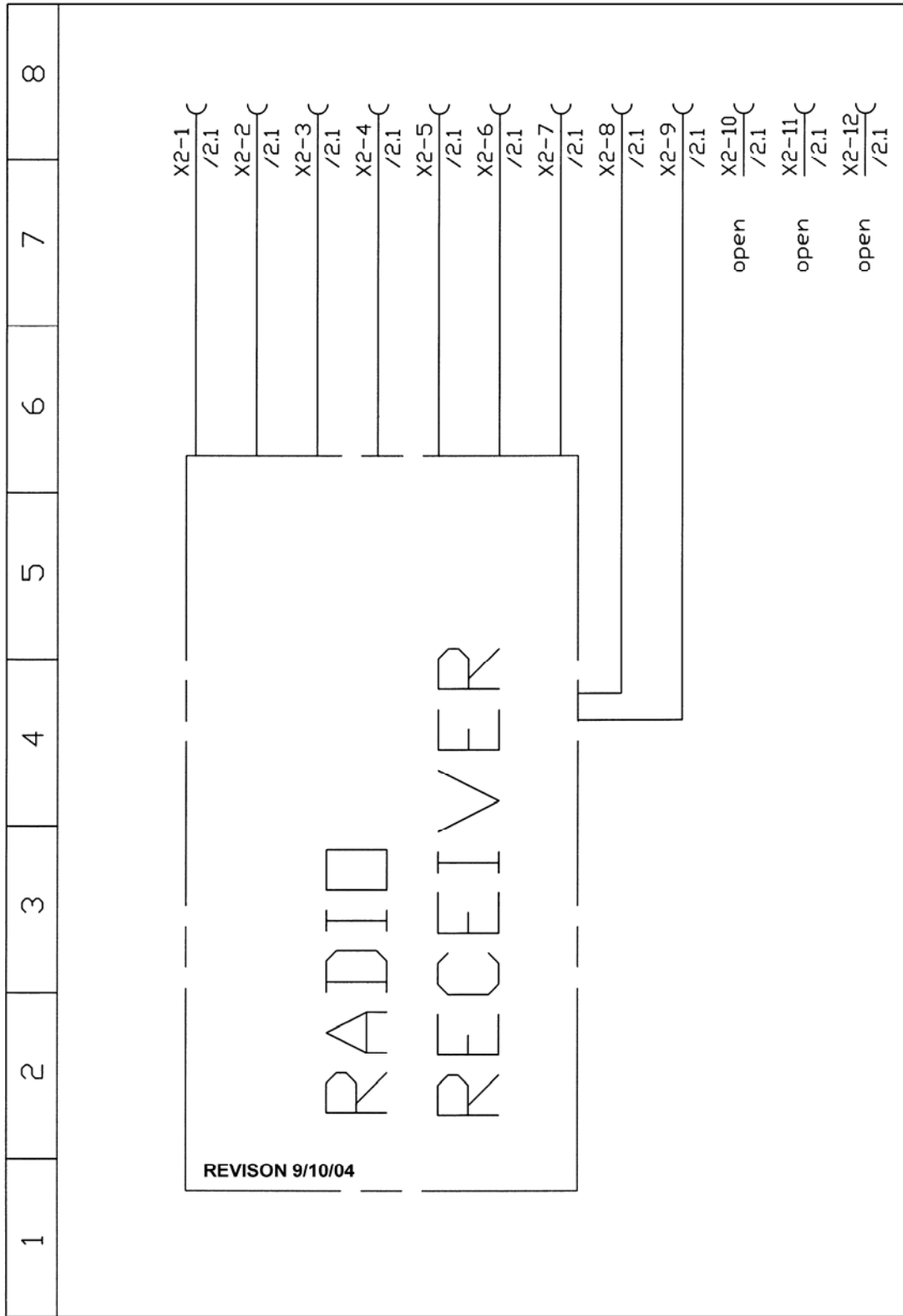

REVISION:



# TRAILER MOUNTED PUMP MODEL A40 ENGINE WIRING HARNESS

SCMTC

PAGE 03

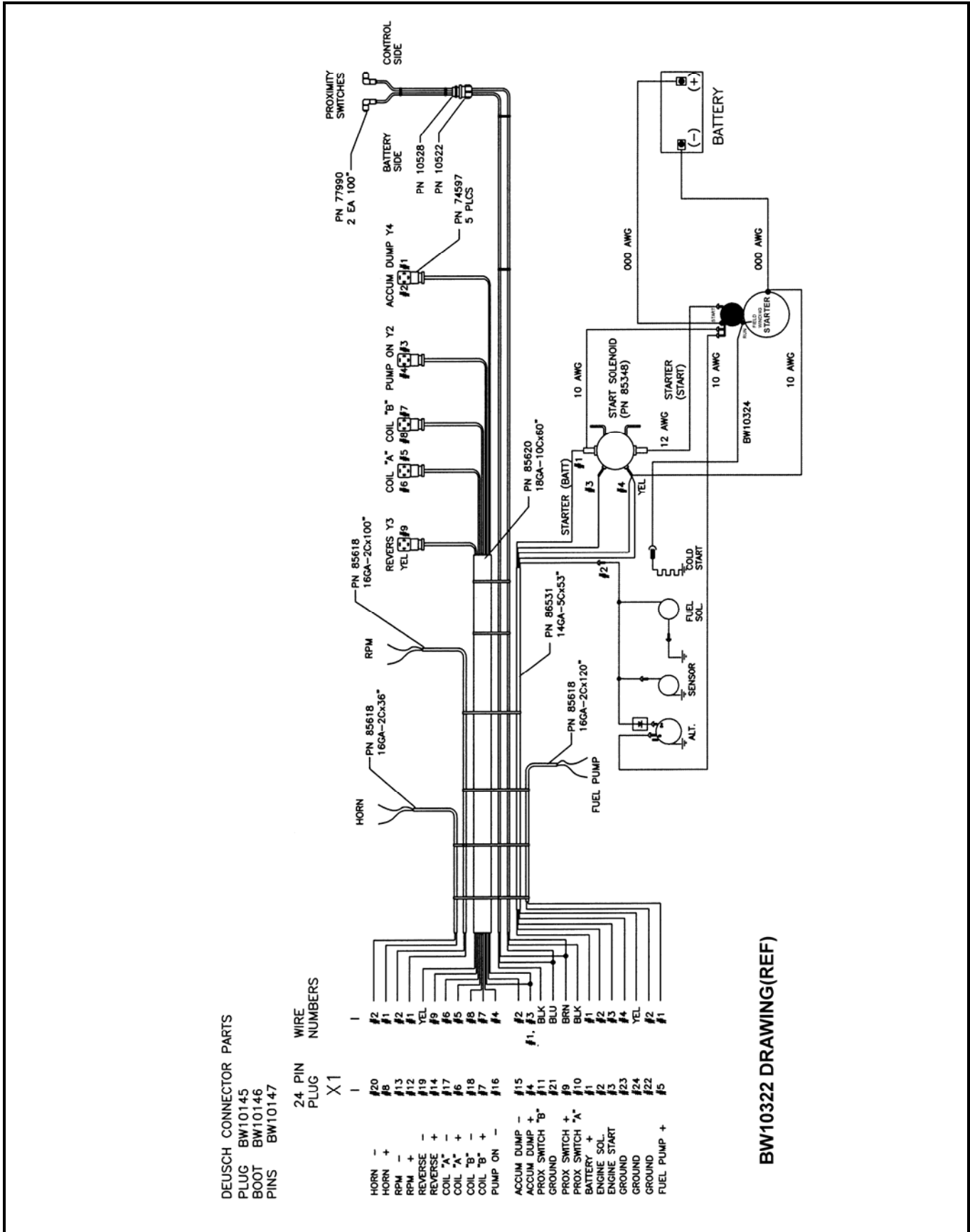

BW10322 DRAWING(REF)

REVISION:



# TRAILER MOUNTED PUMP MODEL A40 TRAILER WIRING HARNESS

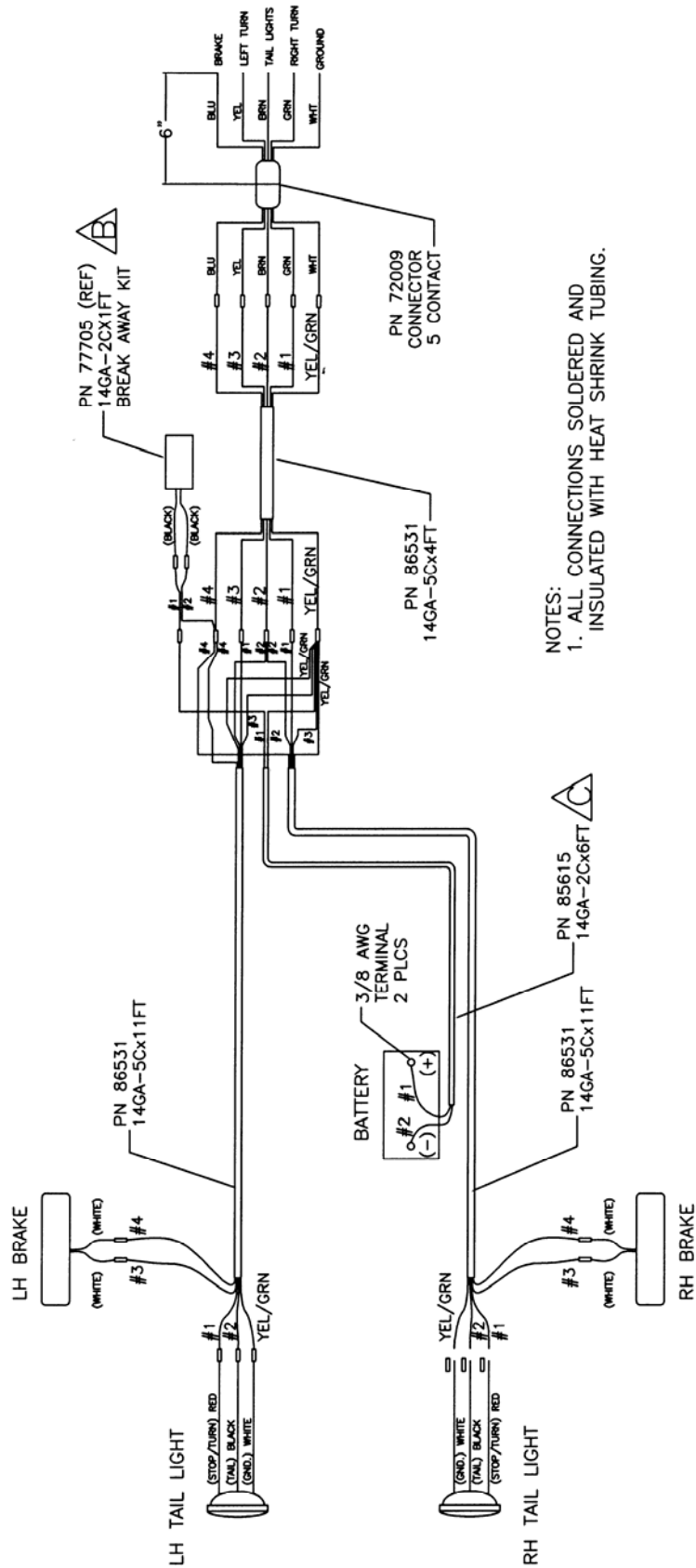

NOTES:  
1. ALL CONNECTIONS SOLDERED AND INSULATED WITH HEAT SHRINK TUBING.

BW10139 DRAWING(REF)

REVISION:



# TRAILER MOUNTED PUMP MODEL A40 ILLUSTRATED PART MANUAL

**A40**  
**PARTS**  
GROUP 00  
FIGURE 00  
PAGE 01

**REED TRAILER MOUNTED CONCRETE PUMP MODEL A40 ILLUSTRATED PARTS MANUAL CONTAINS THE FOLLOWING GROUPS AND FIGURES:**

## **GROUP 00 HOW TO USE PARTS MANUAL**

- FIGURE 00** TABLE OF CONTENTS
- FIGURE 01** HOW TO USE PARTS MANUAL
- FIGURE 02** HOW TO ORDER PARTS

## **GROUP 10 FINAL INSTALLATION**

- FIGURE 00** TABLE OF CONTENTS
- FIGURE 01** FINAL INSTALLATION
- FIGURE 02** DECAL ASSEMBLY

## **GROUP 20 HOPPER INSTALLATION**

- FIGURE 00** TABLE OF CONTENTS
- FIGURE 01** HOPPER INSTALLATION
- FIGURE 02** HOPPER CLEAN OUT DOOR ASSEMBLY

## **GROUP 30 TANK INSTALLATION**

- FIGURE 00** TABLE OF CONTENTS
- FIGURE 01** TANK INSTALLATION

## **GROUP 40 POWER TRAIN INSTALLATION**

- FIGURE 00** TABLE OF CONTENTS
- FIGURE 01** POWER TRAIN INSTALLATION
- FIGURE 02** BATTERY MOUNTING ASSEMBLY
- FIGURE 03** HYDRAULIC PUMPS ASSEMBLY
- FIGURE 04** MAIN PUMP ASSEMBLY
- FIGURE 05** DOUBLE AUXILIARY PUMP ASSEMBLY

## **GROUP 50 CONTROLS INSTALLATION**

- FIGURE 00** TABLE OF CONTENTS
- FIGURE 01** CONTROLS INSTALLATION
- FIGURE 02** CONTROL BOX ASSEMBLY
- FIGURE 03** CABLE REMOTE CONTROL ASSEMBLY
- FIGURE 04** RADIO REMOTE CONTROL ASSEMBLY



# TRAILER MOUNTED PUMP MODEL A40 ILLUSTRATED PART MANUAL

**A40**  
**PARTS**  
GROUP 00  
FIGURE 00  
PAGE 02

## GROUP 60 PUMPING TRAIN INSTALLATION

FIGURE 00	TABLE OF CONTENTS
FIGURE 01	PUMPING TRAIN INSTALLATION
FIGURE 02	SWING VALVE ASSEMBLY
FIGURE 03	SWING RAM CYLINDER SUB-ASSEMBLY
FIGURE 04	CONCRETE CYLINDER ASSEMBLY
FIGURE 05	FLUSHBOX ASSEMBLY
FIGURE 06	HYDRAULIC DRIVE CYLINDER ASSEMBLY
FIGURE 07	DRIVE CYLINDER SUB-ASSEMBLY
FIGURE 08	CONTROL WITH CARTRIDGE MANIFOLD ASSEMBLY
FIGURE 09	REVERSE CIRCUIT PILOT SOLENOID VALVE ASSEMBLY
FIGURE 10	MAIN CYCLING CIRCUIT PILOT SOLENOID VALVE ASSEMBLY

## GROUP 70 FRAME INSTALLATION

FIGURE 00	TABLE OF CONTENTS
FIGURE 01	FRAME INSTALLATION
FIGURE 02	HUB AND BRAKE ASSEMBLY
FIGURE 03	NON-OPERATOR SIDE ELECTRIC BRAKE ASSEMBLY
FIGURE 04	OPERATOR SIDE ELECTRIC BRAKE ASSEMBLY

## GROUP 80 OPTIONAL INSTALLATION

FIGURE 00	TABLE OF CONTENTS
FIGURE 01	OPTIONAL INSTALLATION
FIGURE 02	OPTIONAL TOOL KIT ASSEMBLY
FIGURE 03	ACTUATOR BRAKES ASSEMBLY
FIGURE 04	WATER PUMP INSTALLATION
FIGURE 05	WATER PUMP CONTROL VALVE ASSEMBLY
FIGURE 06	WATER PUMP MOTOR ASSEMBLY
FIGURE 07	WATER PUMP ASSEMBLY
FIGURE 08	NON-OPERATOR SIDE HYDRAULIC BRAKE ASSEMBLY
FIGURE 09	OPERATOR SIDE HYDRAULIC BRAKE ASSEMBLY



# TRAILER MOUNTED PUMP MODEL **A40** HOW TO USE PART MANUAL

**A40**  
**PARTS**  
GROUP 00  
FIGURE 01  
PAGE 01

## I. PURPOSE

This parts manual is prepared, issued and/or revised by **REED** Manufacturing, for the exclusive use of its customers and is intended for use in provisioning, requisitioning, storing and issuing replaceable **REED** trailer mounted pump model **A40**. The contents are proprietary to **REED** and are subject to change without notice. The use of any part of this document by any other person or persons or for any other purpose without the written consent of **REED** is expressly prohibited. In addition, **REED** expressly disclaims any and all responsibility arising in or any way related to such **REED's** prior written consent thereto.

The parts number content of this document, arrangement and breakdown sequence of items is compatible with Military Standard (**MS**) and Air Transport Association Specification (**ATA**).

## II. GENERAL SYSTEM OF ASSEMBLY ORDER – Detailed Parts List (Refer to Next Page)

1. This area refers to the corresponding illustration

### MODEL – GROUP – FIGURE – PAGE

A. **MODEL** shows which is **REED's** model number.

B. **GROUP** should be divided with:

00	MODEL <b>A40</b> PARTS MANUAL
10	FINAL INSTALLATION
20	HOPPER INSTALLATION
30	TANK INSTALLATION
40	POWER TRAIN INSTALLATION
50	CONTROL INSTALLATION
60	PUMPING TRAIN INSTALLATION
70	FRAME INSTALLATION
80	OPTIONAL INSTALLATION

C. **FIGURE** belong to the group. Please see page of contents and each group.

D. **PAGE** numbers follow to the right of each figure number.

2. The **ITEM NUMBER** corresponds to the item number shown for the part in illustration. Parts with item number preceded by a dash (such as: -1, -5, -12 etc.) are not illustrated.

3. **PARTS NUMBERS** that carry a **REED** part number.



### DUAL SHIFT SWING VALVE ASSEMBLY

**01 B40**  
**PARTS**  
GROUP 60  
FIGURE 04  
PAGE 02

ITEM NO.	REED'S PARTS NO.	DESCRIPTION					QTY
		1	2	3	4	5	
-1	60-04	Assembly, Dual Shift Swing Valve (See Group 60, Figure 02 for NHA)					Ref
-2	86321	• Assembly, Outlet Group					1
3		• • Nut					6
4	72482	• • Outlet, Machine 5"					1
5		• • Fitting, Grease					2
6	79895	• • Kit, Outlet Seal					1
7	77761	• • • O-Ring, Large					1
8	77762	• • • O-Ring, Small					1
9	86504	• • • Seal, Modified Outlet Thick					1
10	77763	• • • Band, Guide					1
11	77765	• • • Seal, Outlet Thick					1
12	72309	• • Housing, Outlet Seal					1
13		• • Bolt, Hex					6
14		• • Nut, Nylock (attaching parts)					6
15		• • Washer, Lock (attaching parts)					6
16	70042	• • Outlet, Chromed					1
17		• • Bolt, Hex (attaching parts)					6
-18	86317	• Assembly, Swing Tube Group					1
19	85965	• • Weldment, Harsh Swing Tube					1
20	86065	• • Seal, 6 Inch Single Lip					1
21	72310	• • Ring, 6 Inch Single Lip Wear					1
22	86031	• • Plate, Wear					1
23	86086	• • Ring, Anti Chip					2
24		• • Bolt, Flat Head					4
25		• • Washer, Lock					4
26		• • Nut, Hex					4
27		• • Bolt, Hex					6
28		• • Washer, Lock					6
29	85962	• • Seal, Flange Bearing					1
30		• • Pin, Dowel					1
31		• • Fitting, Grease 90					2
32	85133	• • Bearing, 3 Inch Spline Flange					1
33	85294	• • Washer, Thrust					1
34	85134	• • Spacer, Swing Tube Nut					1
35	70825	• • Nut, Swing Tube					1
36		• • Pin Cotter					1
-37	86320	• Assembly, Swing Tube Dual Shift Group					1
38		• • Plug, Pipe					4
39	86052	• • Pin, Spring					4
40		• • Fitting, Grease 90					2
41	86441	• • Retainer, Swing Ram					2

DASH (-) ITEM NOT ILLUSTRATED

REVISION:



# TRAILER MOUNTED PUMP MODEL A40 HOW TO USE PART MANUAL

**A40**  
**PARTS**  
GROUP 00  
FIGURE 01  
PAGE 03

## 4. DESCRIPTION

A. The **INDENTURE SYSTEM** used in the parts list shows the relationship of one part to another. For a given item, the number of indentures depicts the relationship of the item to the components of the item as follows:

**1 2 3 4 5**

**Assembly (or Installation)**

- **Detail part of assembly**
- **Sub-assembly**
- **Attaching parts for sub-assembly**
- • **Detail part of sub-assembly**
- • **Sub-sub-assembly**
- • **Attaching parts for sub-sub-assembly**
- • • **Detail part of sub-sub-assembly**
- • • **Sub-sub-sub-assembly**
- • • **Attaching parts of sub-sub-sub-assembly**
- • • • **Detail part of sub-sub-sub-assembly**

B. "See Group 60, Figure 02 For **NHA**"

Identifies the illustrated parts chapter location; indicates where the Next Higher Assembly (**NHA**) of the item shown.

C. "See Group 60, Figure 07 For **DET**"

Identifies the illustrated parts chapter location; indicates where the item and its Detailed Breakdown (**DET**) is shown.

D. "See Group 30, Figure 05 for **REF**" or "See Vendor Chapter For **REF**"

Identifies the illustrated parts chapter where the part is, and if listed and illustrated in Vendor Chapter. It is used as a cross-reference (**REF**).

## 5. QUANTITY

A. Reference (**REF**) indicates the items that is listed previously in the Next Higher Assembly (**NHA**) and then again in this figure.

B. As Required (**A/R**) indicates the parts that is used in a quantity as required.

C. A number entry indicates the quantity of the part used in its next higher application.

6. Functionally related assemblies are illustrated in phantom (— — — —) but not listed on the detail parts list page.





# TRAILER MOUNTED PUMP MODEL A40 HOW TO ORDER PARTS

**A40**  
**PARTS**  
GROUP 00  
FIGURE 02  
PAGE 01

1. Always give serial number and model of **REED** trailer mounted concrete pump model **A40**. (Refer to each unit name plate shown below). NOTE: This manual is being released to cover unit starting with serial number **3-07-1-XXXX** to current production. Some components used on earlier units differ from current productions. Where this occurs, the part is identified by a serial number.

<b>REED</b>		PHONE (909) 287 - 2100	
13822 OAKS AVENUE		FAX (909) 287 - 2140	
CHINO, CA 91710 USA			
MODEL	_____	SERIAL NO	_____
MATERIAL PRESSURE	_____	PSI	_____ 3AR
HYDRAULIC PRESSURE	_____	PSI	_____ 3AR
ENGINE / PTO ELECTRIC MOTOR	_____	RPM	_____ /OLTS
PN 36636			

2. Always specify part number and complete name of parts ordered.

- A. Turn to table of content in the desired Installation. Refer to main group in which part should be listed.
- B. Find title of figure in which the part should be shown. Note figure number.

REED

TRAILER MOUNTED PUMP 01 MODEL B40  
GROUP 60 PUMPING TRAIN INSTALLATION

01 B40  
PARTS  
GROUP 60  
FIGURE 00  
PAGE 01

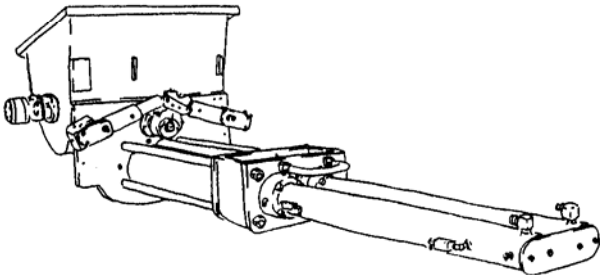

SHOWN MODEL DUAL SHIFT  
HARSH MIX HOPPER UNIT

REED TRAILER MOUNTED CONCRETE PUMP 01 MODEL B45 ILLUSTRATED PARTS MANUAL GROUP 60 PUMPING TRAIN INSTALLATION CONTAINS THE FOLLOWING FIGURES:

FIGURE 00	TABLE OF CONTENTS
FIGURE 01	SINGLE SHIFT PUMPING TRAIN INSTALLATION
FIGURE 02	DUAL SHIFT PUMPING TRAIN INSTALLATION
FIGURE 03	SINGLE SHIFT SWING VALVE ASSEMBLY
FIGURE 04	DUAL SHIFT SWING VALVE ASSEMBLY
FIGURE 05	SINGLE SHIFT SWING RAM CYLINDER SUB-ASSEMBLY
FIGURE 06	DUAL SHIFT SWING RAM CYLINDER SUB-ASSEMBLY
FIGURE 07	MATERIAL CYLINDER ASSEMBLY
FIGURE 08	FLUSHBOX ASSEMBLY
FIGURE 09	HYDRAULIC DRIVE CYLINDER ASSEMBLY
FIGURE 10	HYDRAULIC DRIVE CYLINDER SUB-ASSEMBLY

REVISION:

REVISION:



# TRAILER MOUNTED PUMP MODEL A40 HOW TO ORDER PARTS

**A40**  
**PARTS**  
GROUP 00  
FIGURE 02  
PAGE 02

**REED** **DUAL SHIFT SWING VALVE ASSEMBLY** 01 B40 PARTS GROUP 00 FIGURE 04 PAGE 01

HOPPER REF (STANDARD P/N: 86107) (HARSH MIX P/N: 86032)

SWING RAM HOUSE REF (RH P/N: 85941) (LH P/N: 85942)

HOPPER REF (STANDARD P/N: 86107) (HARSH MIX P/N: 86032)

REVISION:

**REED** **DUAL SHIFT SWING VALVE ASSEMBLY** 01 B40 PARTS GROUP 00 FIGURE 04 PAGE 02

ITEM NO.	REED'S PARTS NO.	DESCRIPTION	QTY
-1	60-04	Assembly, Dual Shift Swing Valve (See Group 60, Figure 02 for NHA)	Ref
-2	86321	• Assembly, Outlet Group	1
3		• • Nut	6
4	72482	• • Outlet, Machine 5"	1
5		• • Fitting, Grease	2
6	79895	• • Kit, Outlet Seal	1
7	77761	• • • O-Ring, Large	1
8	77762	• • • O-Ring, Small	1
9	86504	• • • Seal, Modified Outlet Thick	1
10	77763	• • • Band, Guide	1
11	77765	• • • Seal, Outlet Thick	1
12	72309	• • Housing, Outlet Seal	1
13		• • Bolt, Hex	6
14		• • Nut, Nylock (attaching parts)	6
15		• • Washer, Lock (attaching parts)	6
16	70042	• • Outlet, Chromed	1
17		• • Bolt, Hex (attaching parts)	6
-18	86317	• Assembly, Swing Tube Group	1
19	85965	• • Weldment, Harsh Swing Tube	1
20	86085	• • Seal, 6 Inch Single Lip	1
21	72310	• • Ring, 6 Inch Single Lip Wear	1
22	86031	• • Plate, Wear	1
23	86086	• • Ring, Anti Chip	2
24		• • Bolt, Flat Head	4
25		• • Washer, Lock	4
26		• • Nut, Hex	4
27		• • Bolt, Hex	6
28		• • Washer, Lock	6
29	85962	• • Seal, Flange Bearing	1
30		• • Pin, Dowel	1
31		• • Fitting, Grease 90	2
32	86793	• • Bearing, 3 Inch Spine Flange	1
33	85294	• • Washer, Thrust	1
34	86787	• • Spacer, Swing Tube Rod	1
35	70625	• • Nut, Swing Tube	1
36		• • Pin Cotter	1
-37	86320	• Assembly, Swing Tube Dual Shift Group	1
38		• • Plug, Pipe	4
39	86082	• • Pin, Spring	4
40		• • Fitting, Grease 90	2
41	86441	• • Retainer, Swing Ram	2

DASH (-) ITEM NOT ILLUSTRATED

REVISION:

**C.** Turn to corresponding page, find the group and figure.

**D.** Check your required part and its attaching parts and match with illustration page.

**E.** Refer to corresponding item number in the part list page. Part numbers are located in the part number column.

**F.** When ordering variable or optional miscellaneous parts which are not found this in parts chapter, follow the above outlined procedure of how to order parts.

- 1). When applicable, give model and serial number of the component for which parts are desired.
- 2). In a specific, difficult to describe situation, a marked-up photograph or detailed sketch would be helpful.

REVISION:



## TRAILER MOUNTED PUMP MODEL *A40* HOW TO ORDER PARTS

*A40*  
**PARTS**  
GROUP 00  
FIGURE 02  
PAGE 03

3. Do not designate quantity by "set". State specifically how many parts are wanted.
4. Always give complete address and full shipping instructions. Specify shipping instructions, truck freight, air freight. United Parcel Service (UPS), or FEDEX and DHL are available in designated areas.

### 5. TO ORDER

#### A. BY MAIL

Attention: Parts Department  
**REED LLC**  
13822 Oaks Avenue  
Chino, CA. 91710

#### B. BY FAX

(909) 287 - 2141

#### C. BY PHONE

(909) 287 - 2100

6. Parts return without authorization will not be accepted. If it is necessary to return parts for any reason, written authorization may be obtained from **REED** Parts Department, Chino, CA. 91710. A Parts Return Authorization form is provided when **REED** deems its necessary to have the part returned for evaluation. The form is issued by the Warranty of Parts Department of **REED**.
  - A. The form will be filled by **REED** unless requesting necessary information and you will receive a copy as well as shipping tag.
  - B. Attach shipping tag to part insert return original invoice.
  - C. Ship part to **REED PREPAID**.
  - D. Part must be returned to **REED** within 30 days from date of authorization.

**REED TRAILER MOUNTED CONCRETE PUMP 00 MODEL A40 ILLUSTRATED PARTS MANUAL GROUP 10 FINAL INSTALLATION CONTAINS THE FOLLOWING FIGURES:**

- FIGURE 00** TABLE OF CONTENTS
- FIGURE 01** FINAL INSTALLATION
- FIGURE 02** DECAL ASSEMBLY

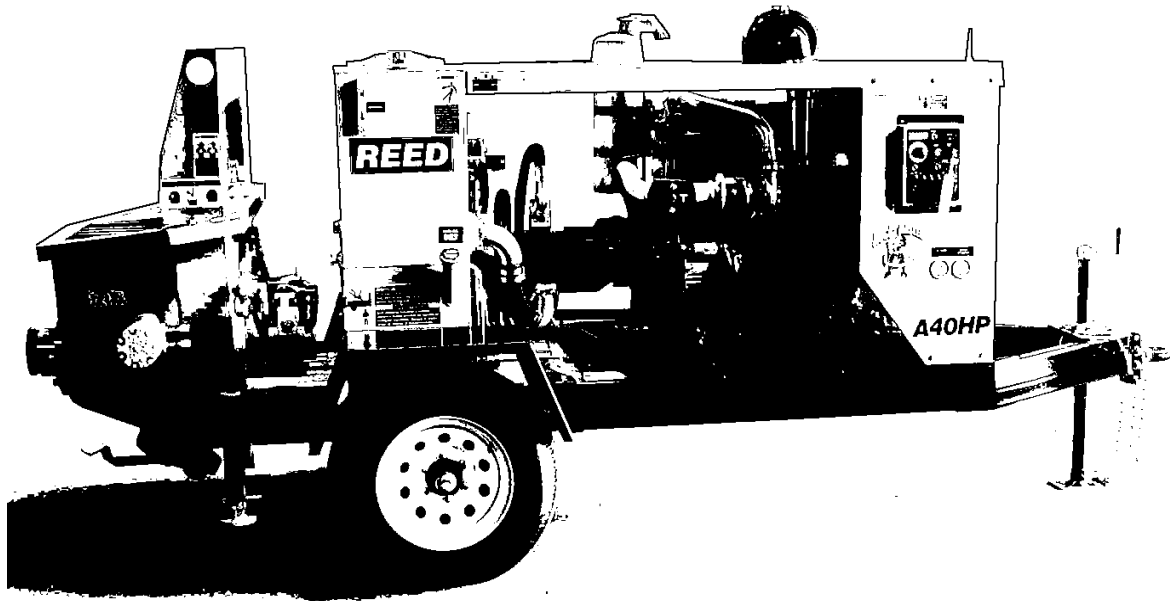



# TRAILER MOUNTED PUMP MODEL A40 FINAL INSTALLATION

A40  
PARTS  
GROUP 10  
FIGURE 01  
PAGE 01

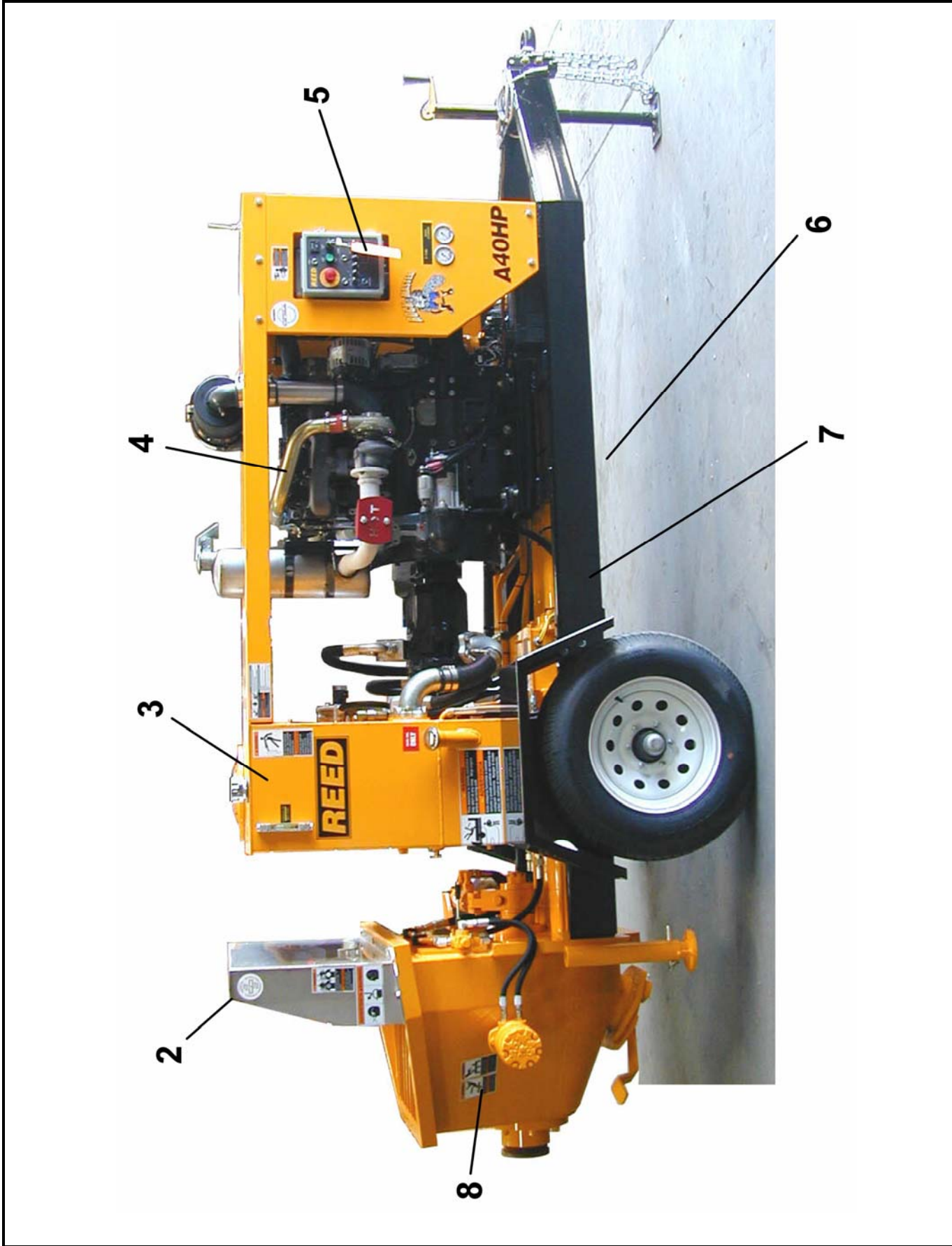

REVISION:



**FINAL INSTALLATION  
GROUP 10 FINAL INSTALLATION**

**A40  
PARTS  
GROUP 10  
FIGURE 01  
PAGE 02**

ITEM NO.	REED'S PARTS NO.	DESCRIPTION	QTY
		1 2 3 4 5	
-1	<b>A40-V00</b>	Installation, <b>A40HP</b> Final	Ref
2	20-02	• Installation, Hopper (See Group 20, Figure 01 for DET)	1
3	30-01	• Installation, Tank (See Group 30, Figure 01 for DET)	1
4	40-01	• Installation, Power Train (See Group 40, Figure 01 for DET)	1
5	50-01	• Installation, Control (See Group 50, Figure 01 for DET)	1
6	60-01	• Installation, Single Shift Pumping Train (See Group 60, Figure 01 for DET)	1
7	70-01	• Installation, Frame (See Group 70, Figure 01 for DET)	1
8	10-02	• Kit, <b>A40HP</b> Decal (See Group 10, Figure 02 for DET)	1

REVISION:





**DECAL ASSEMBLY  
GROUP 10 FINAL INSTALLATION**

**A40  
PARTS**  
GROUP 10  
FIGURE 02  
PAGE 01

ITEM NO.	REED'S PARTS NO.	DESCRIPTION					QTY
		1	2	3	4	5	
-1	10-02	Group, <b>A40HP</b> Decal (See Group 10, Figure 01 for NHA)					Ref
2	BW10406	• Decal, <b>A40HP</b>					2
3	BW10100	• Decal, <b>ROCKMAN</b>					2
4	BW10121	• Kit, A-Series Decal					1
5	800916	• • Decal, Warning, Keep Hand Out of Water Box					1
6	BW10128	• • Decal, <b>REED</b> 4 ¼ X 12 ½ Inch					3
7	800924	• • Decal, Warning, This Machine is Remote Controlled and					2
8	800929A	• • Decal, Warning					2
9	800931	• • Decal, <b>ACPA</b> Member					1
10	85844	• • Decal, Oil Level					1
11	75020	• • Decal, Hydraulic Oil					1
12	75017	• • Decal, Diesel Fuel Only					1
13	800925	• • Decal, Warning, Do Not Operate This Machine without					1
14	86636	• • Nameplate, <b>REED</b> , Serial No.					1
15	800921	• • Decal, Warning, Do Not Operate at Pressures Exceeding					1
16	73132	• • Decal, <b>REED</b> 4 1/2 Inch					1
17	800922	• • Decal, Warning, Before Opening a Blocked Pipeline					1
18	800918	• • Decal, Warning, Do Not Stand on Hopper Grate					2
19	BW10351	• • Decal, Gauges					1
20	803225	• • Decal, Leaks Hazard					2
21	803226	• • Decal, How to Order					1
22	803229	• • Decal, <b>CPMA</b> Member					1
23	803231	• • Decal, Toxic Dust					2
24	803235	• • Decal, 1-7 Operation Signals					1
25	803237	• • Decal, Pressurized Pipes					2
26	800917	• • Decal, Warning, No Hands - Hopper					2
DASH (-) ITEM NOT ILLUSTRATED							

REVISION:



DECAL ASSEMBLY  
GROUP 10 FINAL INSTALLATION

A40  
PARTS  
GROUP 10  
FIGURE 02  
PAGE 02

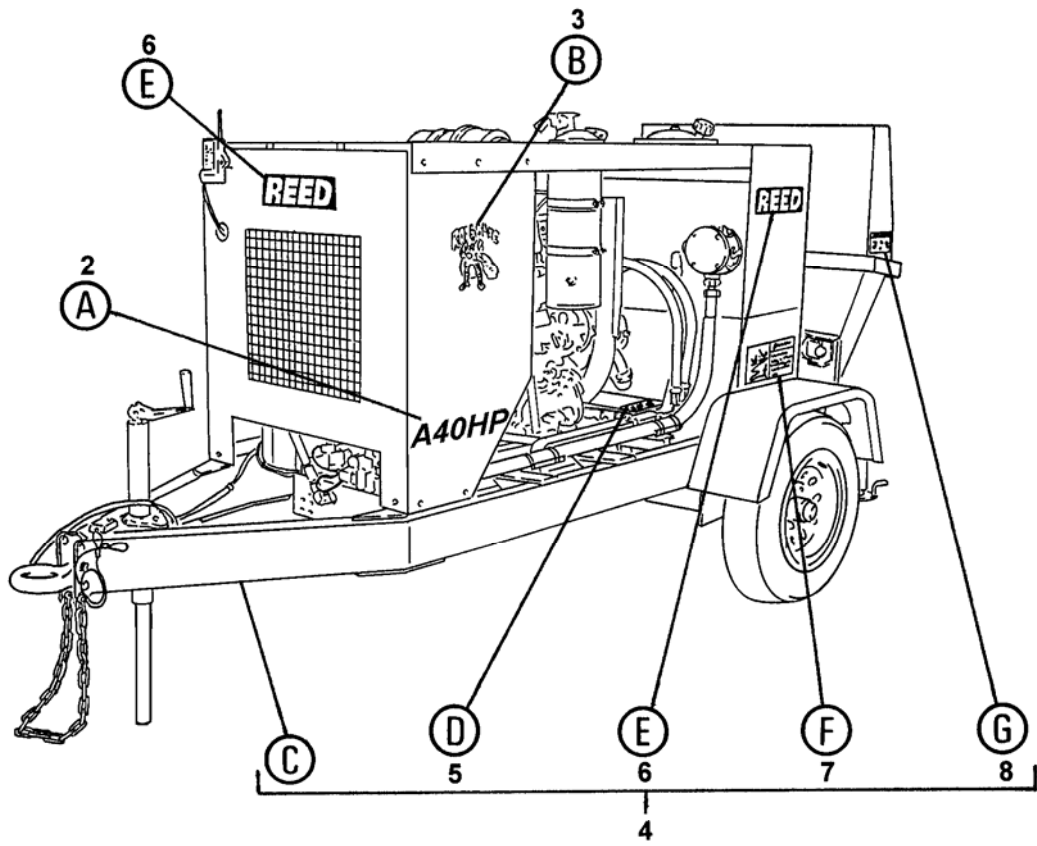

**A40HP**

(B)

3

2

(A)





DECAL ASSEMBLY  
GROUP 10 FINAL INSTALLATION

A40  
PARTS  
GROUP 10  
FIGURE 02  
PAGE 03

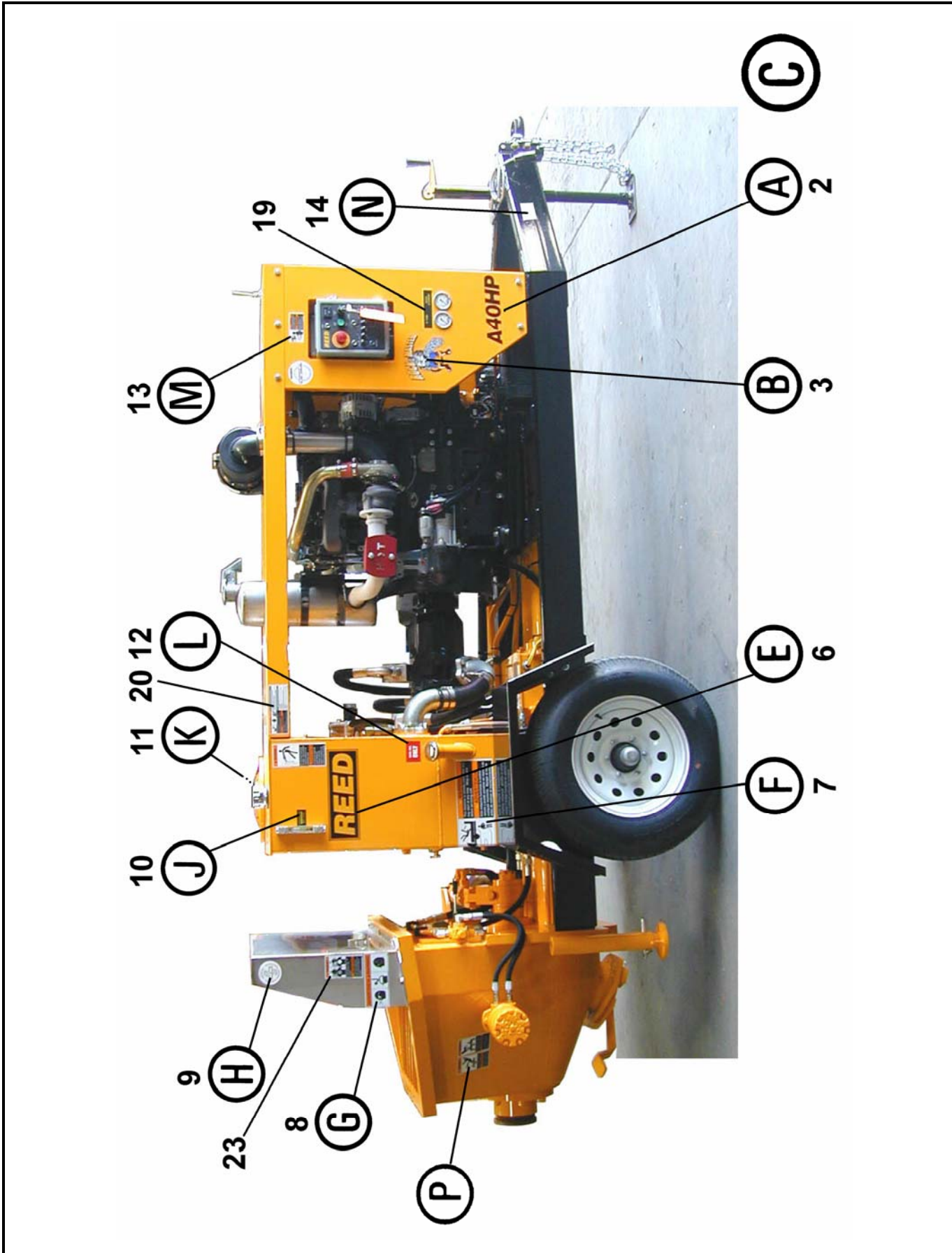

REVISION:



**⚠ WARNING**  
Keep hands out of waterbox.  
Stop motor if access is required.  
Keep guards in place.

**⚠ ADVERTENCIA**  
No meta las manos a la caja de agua.  
Pare el motor si necesita tener acceso.  
Mantenga las cubiertas cerradas.

Do not paint over this label/No pintar encima de ésta etiqueta 800916

5  
D



6  
E



**⚠ WARNING**  
This machine is remote controlled and  
may start at any time. Stop engine  
before servicing unit.

**⚠ ADVERTENCIA**  
Esta máquina funciona a control  
remoto y puede ponerse en marcha en  
cualquier momento. Apagar el motor  
antes de realizar el mantenimiento.

7  
F



**G**  
8



**H**  
9



**M**  
13

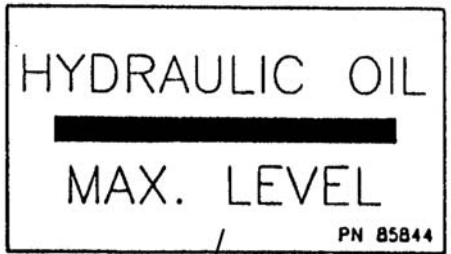

**J**  
10



**L**  
12

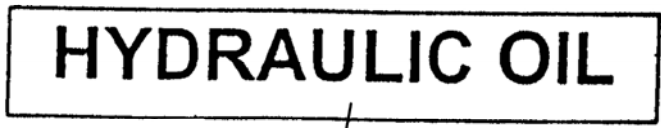

**K**  
11



# DECAL ASSEMBLY GROUP 10 FINAL INSTALLATION

A40  
PARTS  
GROUP 10  
FIGURE 02  
PAGE 06

<b>REED</b> 13822 OAKS AVENUE CHINO, CA 91710 USA		PHONE (909) 287 - 2100 FAX (909) 287 - 2140	
MODEL	_____	SERIAL NO.	_____
MATERIAL PRESSURE	_____	PSI	_____ BAR
HYDRAULIC PRESSURE	_____	PSI	_____ BAR
ENGINE / PTO ELECTRIC MOTOR	_____	RPM	_____ VOLTS
PN 86636			

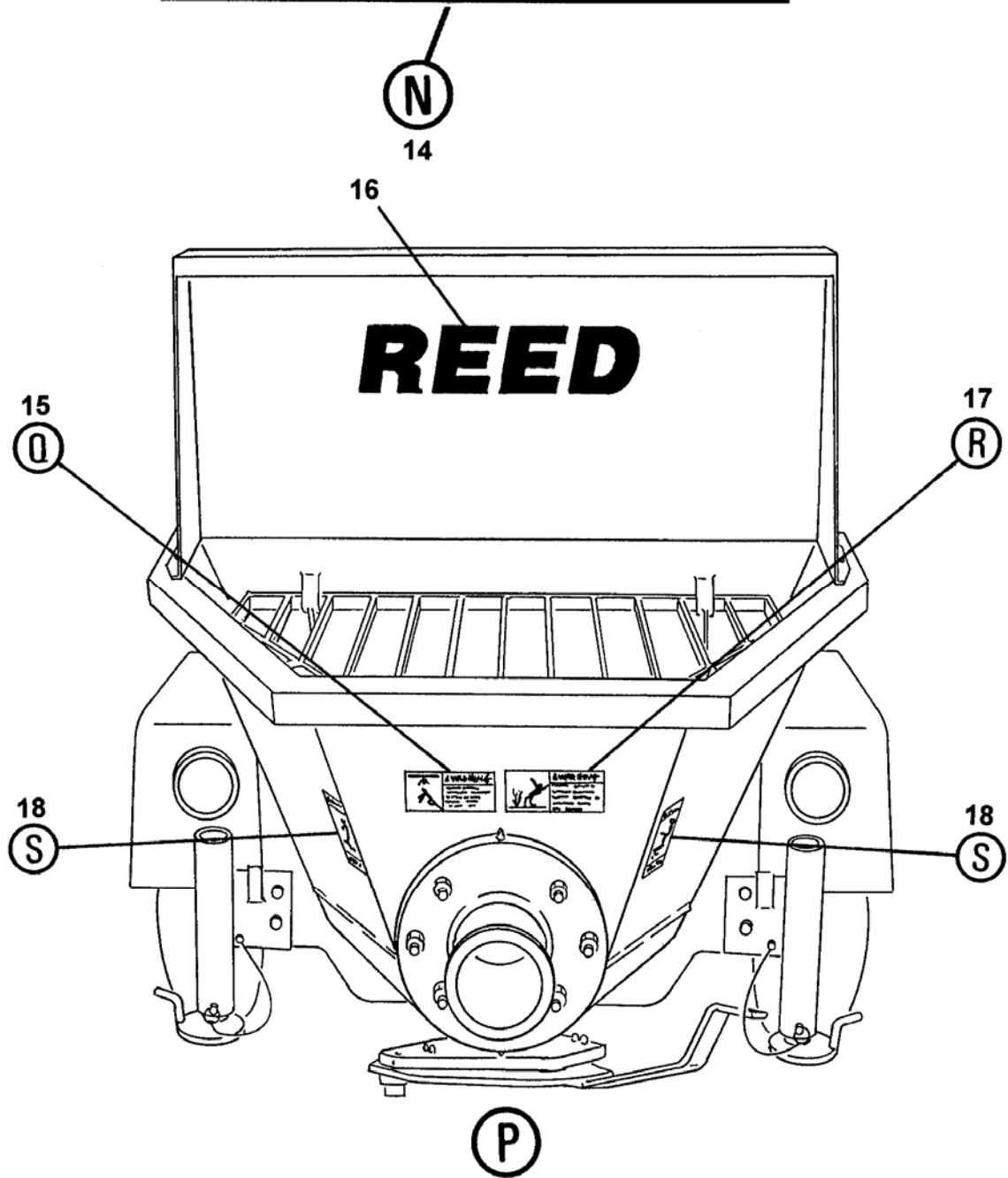

REVISION:





**⚠ WARNING**  
Do not operate at pressures exceeding the rating of the entire material delivery system.

**⚠ ADVERTENCIA**  
No utilizar a presiones que excedan la presión nominal de todo el material de la línea de entrega.

Q  
15

Do not paint over this label/No pintar encima de ésta etiqueta 800921



**⚠ WARNING**  
Before opening a blocked pipeline, relieve pressure by reversing pump. See manual.

**⚠ ADVERTENCIA**  
Alivie la presión antes de destapar una tubería bloqueada, invirtiendo para ello la bomba. Vea el manual.

R  
17

Do not paint over this label/No pintar encima de ésta etiqueta 800922

**⚠ WARNING**

Stay off hopper grates.

**⚠ ADVERTENCIA**

Manténgase alejado de la rejilla que cubren la tolva.

S  
18

Do not paint over this label/No pintar encima de ésta etiqueta

800918

S-TUBE DRIVE CYLINDER 19

**WARNING**

Do not touch hydraulic oil leaks. Get immediate medical attention if oil penetrates skin.

**ADVERTENCIA**

No toque las fugas de aceite hidráulico. Obtenga atención médica inmediata si el aceite penetra en la piel.

20

**INSTRUCCIONES DE SEGURIDAD SAFETY INSTRUCTIONS**

1. START PUMP SPEED UP	2. SLOW PUMP DOWN	3. STOP PUMP	4. LITTLE BIT	5. RELIEVE PRESSURE	6. ADD WATER 4-GALLONS	7. ALL DONE CLEAN UP
1. PRENDER LA BOMBA ACELERAR	2. BAJAR VELOCIDAD A LA BOMBA	3. PARAR LA BOMBA	4. UN POCO	5. ALIVIAR LA PRESIÒ	6. AÑADIR AGUA 4-GALONES	7. TERMINADO LIMPIAR

24

**WARNING**

Stay clear of pressurized concrete placing system. Do not operate at pressures exceeding the rating of any piece of the material delivery system.

**ADVERTENCIA**

Permanezca alejado del sistema de distribución de concreto presurizado. Use protección para los ojos. No opere a presiones mayores que las de la capacidad de cualquier parte del sistema de descarga.

**SAFETY INSTRUCTIONS**

- Relieve system pressure before opening any system or coupling.
- Regularly inspect system condition and wall thickness.
- Wear reduces system burst pressure.
- Use recommended clean out procedures - consult manufacturer.
- Use retaining pins in delivery system snap couplings.

**INSTRUCCIONES DE SEGURIDAD**

- Alivie la presión del sistema ante de abrir un sistema o un acoplamiento.
- Inspeccione periódicamente el estado del sistema y el espesor de las paredes.
- El desgaste reduce la presión de rotura por estallido.
- Use los procedimientos de limpieza recomendados, consulte con el fabricante.
- Use los pasadores de retención en los acoplamientos de fijación a presión.

25

**IMPORTANT**

You can order additional operation manuals, spare parts books, safety manuals and decal sets by contacting us at:  
REED Manufacturing  
1-(888)-779-7333  
7:00 AM to 5:00 PM  
Pacific Time  
Monday through Friday

**IMPORTANTE**

Usted puede solicitar manuales de operación, catálogos de refacciones, manuales de seguridad y juegos de calcomanías adicionales contactando a:  
REED Manufacturing  
1-(888)-779-7333  
DE 7:00 AM a 5:00 PM  
Hora Central

21

**WARNING**

Keep hands out of hopper and valve assembly. See operation manual if access is required.

**ADVERTENCIA**

No meta las manos a la tolva o válvula. Consulte el manual de operación si necesita tener acceso.

26



22

**WARNING**

Cement dust is toxic. Use lung protection when exposed.

**ADVERTENCIA**

El polvo de cemento es tóxico. Use protección para los pulmones cuando se exponga.

23



**DECAL ASSEMBLY  
GROUP 10 FINAL INSTALLATION**

**A40  
PARTS**  
GROUP 10  
FIGURE 03  
PAGE 01

THIS PAGE INTENTIONALLY LEFT BLANK.

**REED TRAILER MOUNTED CONCRETE PUMP MODEL A40 ILLUSTRATED PARTS  
MANUAL GROUP 20 HOPPER INSTALLATION CONTAINS THE FOLLOWING  
FIGURES:**

- FIGURE 00** TABLE OF CONTENTS
- FIGURE 01** HOPPER INSTALLATION
- FIGURE 02** HOPPER CLEAN OUT DOOR ASSEMBLY

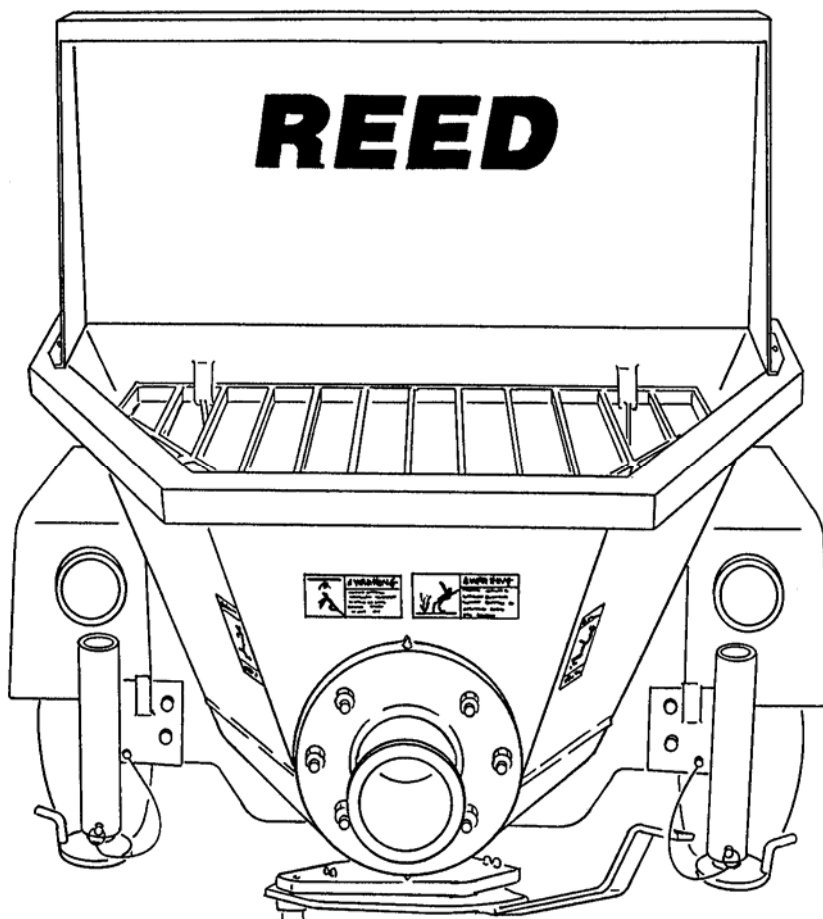





# HOPPER INSTALLATION

A40  
PARTS  
GROUP 20  
FIGURE 01  
PAGE 01

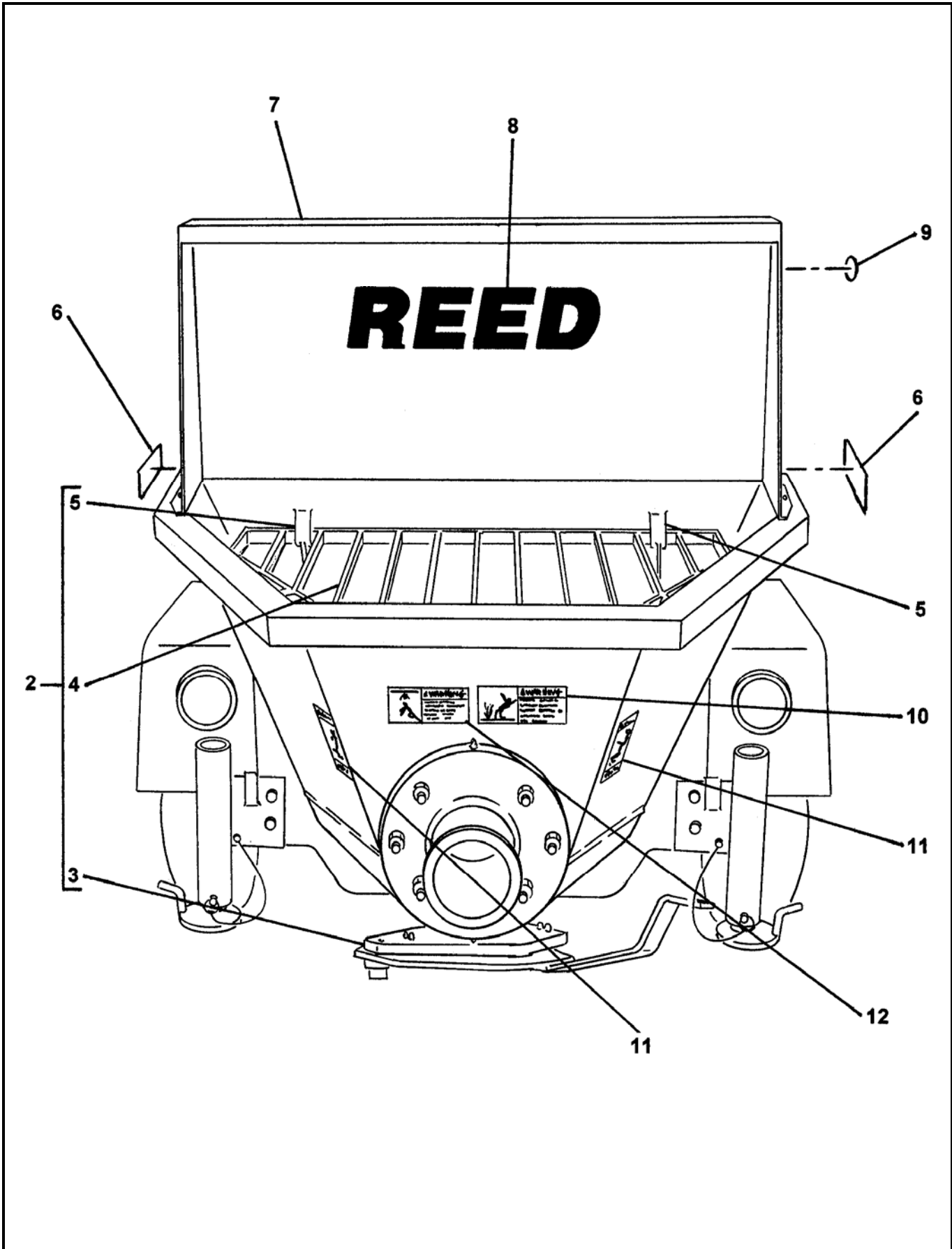

REVISION:



# HOPPER INSTALLATION

ITEM NO.	REED'S PARTS NO.	DESCRIPTION	QTY
		1 2 3 4 5	
-1	BW24040	Group, Hopper (See Group 10, Figure 01 for NHA)	Ref
2	BW10363	• Weldment, Hopper	1
3	86542	•• Assembly, Clean Out Door (See Group 20, Figure 02 for DET)	1
4	BW10042	•• Grate, Hopper	1
5	72679	•• Hinge, Grate	
6	800929A	• Decal, Warning	2
7	85714	• Guard, Splash	1
8	73132	• Decal, <b>REED</b> 4 ½ Inch	1
9	800931	• Decal, <b>ACPA</b> Member	1
10	800922	• Decal, Warning, Before Opening a Blocked Pipeline,	1
11	800917	• Decal, Warning, Keep Hand Out of Hopper and Valve	2
-12	73433	• Cover-Remix	1
-13	73434	• Cover Plate	1
-14	86623	• Seal, Agitator	1
-15	Bw10384	• Spacer, Ring	1
		DASH (-) ITEM NOT ILLUSTRATED	



# HOPPER CLEAN OUT DOOR ASSEMBLY

A40  
PARTS  
GROUP 20  
FIGURE 02  
PAGE 01

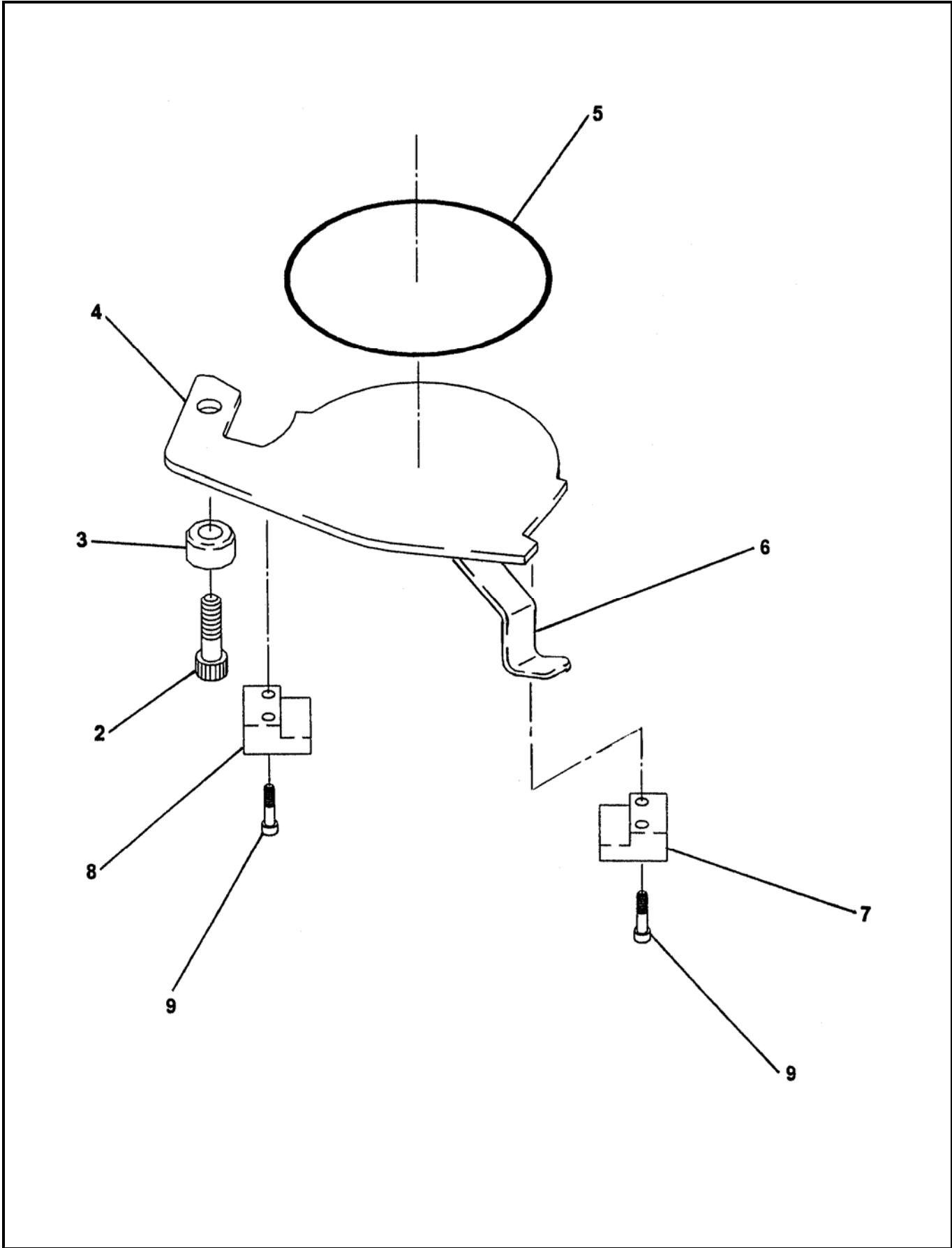

REVISION:



# HOPPER CLEAN OUT DOOR ASSEMBLY

**A40**  
**PARTS**  
GROUP 20  
FIGURE 02  
PAGE 02

ITEM NO.	REED'S PARTS NO.	DESCRIPTION	QTY
		1 2 3 4 5	
-1	86542	Assembly, Rounded Clean Out Door (See Group 20, Figure 01 for NHA )	Ref
2		• Bolt, Shoulder	1
3	85367	• Boss, Clean Out Door	1
4	86988	• Door, Clean Out	1
5	W-102908A	• Cord, Hopper Door O-Ring 2.21 FT	1
6	86541	• Handle, Clean Out Door	1
7	86560	• Block, RH Clean Out Door	1
8	86559	• Block, LH Clean Out Door	1
9		• Screw, Socket Head Cap	4
-10	85312	• Plate, Seal	1
-11	85371	• Neck, Clean Out Door	1

DASH (-) ITEM NOT ILLUSTRATED

THIS PAGE INTENTIONALLY LEFT BLANK.

**REED TRAILER MOUNTED CONCRETE PUMP MODEL A40 ILLUSTRATED PARTS MANUAL GROUP 30 HYDRAULIC TANK INSTALLATION CONTAINS THE FOLLOWING FIGURES:**

- FIGURE 00** TABLE OF CONTENTS
- FIGURE 01** TANK INSTALLATION

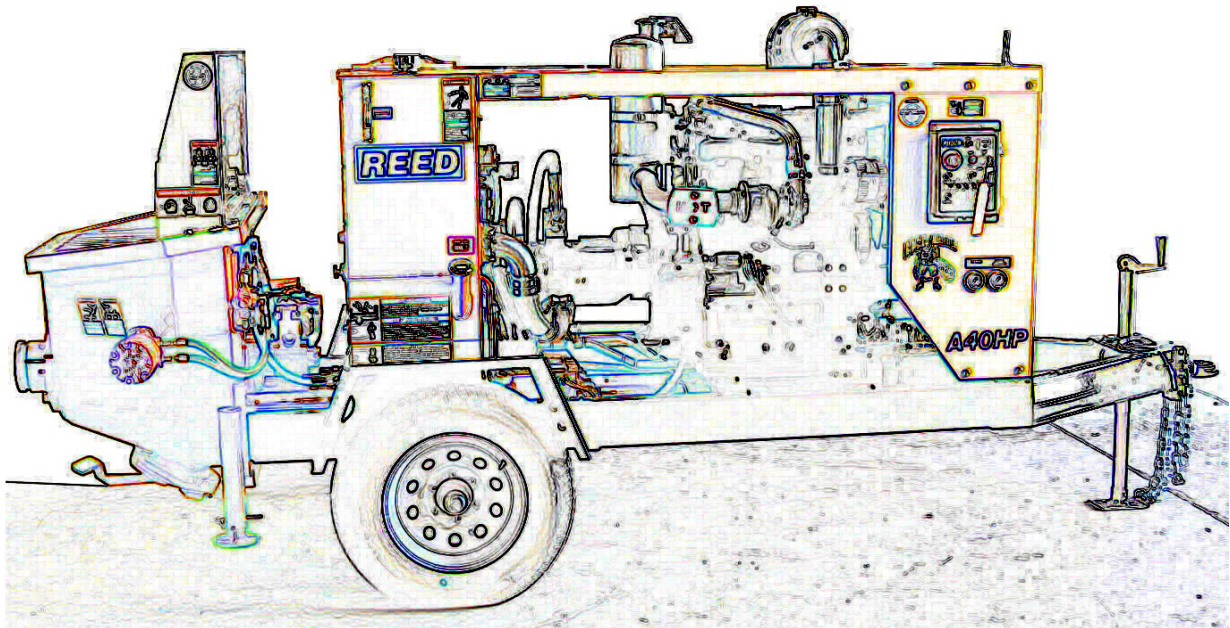



## TANK INSTALLATION

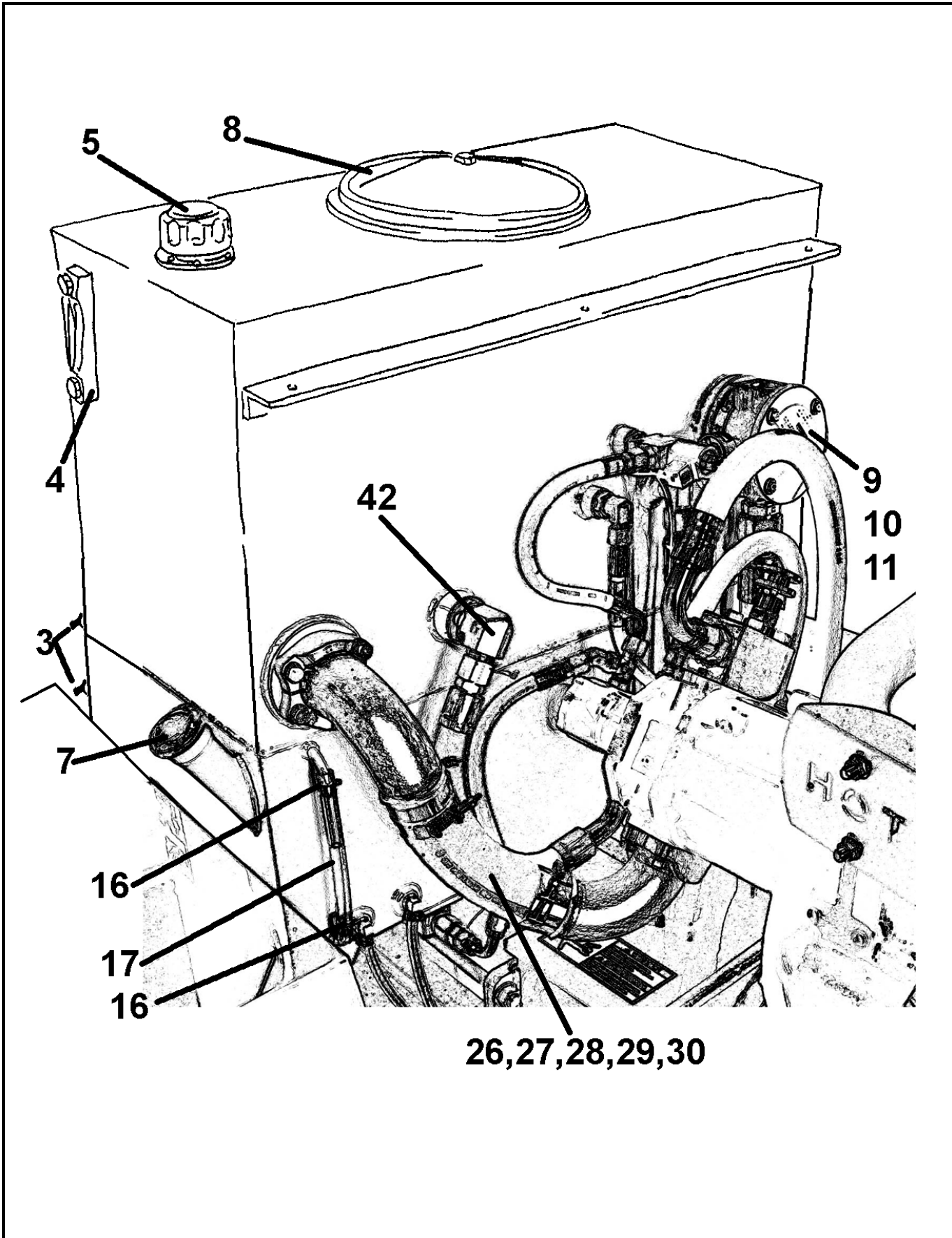



# TANK INSTALLATION

ITEM NO.	REED'S PARTS NO.	DESCRIPTION	QTY
		1 2 3 4 5	
-1	BW43020	Hydraulic/Fuel Group (See Group 10, Figure 01 for NHA)	Ref
-2	BW10397	• Assembly, A-Series Hydraulic / Fuel Tank	1
3	801025	• • Cock, ¼ Drain	2
4	74509	• • Gauge, Sight and Temperature	1
5	74508	• • Breather, Filler with Cap	1
6	BW10386	• • Weldment, A-Series Hydraulic / Fuel Tank	1
7	BW10256	• • • Cap, Filler	1
8	BW10171	• • • Kit, 12 Inch End Cover	1
9	BW10027	• • Filter, Return	1
10	BW10106	• • • Element, Filter	1
11		• • • Gauge, Filter	1
12	BW10162	• Assembly, Hydraulic Hose	1
13	BW10046	• Assembly, Return Line Hydraulic Hose	1
14	BW10047	• Assembly, Main Pump Hydraulic Hose	2
15	BW10051	• Assembly, Hydraulic Hose	2
16	802289	• Clamp, Worm	2
17	801978	• Tubing, Clear PVC	1
18	BW10049	• Assembly, Swing Cylinder Hydraulic Hose	2
19	BW10154	• Assembly, Swing Cylinder Hydraulic Tube	2
20	801902-006	• Clamp, Tube	4
21	801902-001	• Nut, Tube Clamp Tee	10
22	801902-007	• Clamp, Tube	6
23	BW10150	• Assembly, Main Pump Pressure Hydraulic Tube	1
24	BW10403	• Assembly, Main Pump Pressure Hydraulic Tube	1
25	BW10153	• Assembly, Return Line Hydraulic Tube	1
26	86264-005	• Split Flange	1
27	86264-006	• Split Flange	1
28	85661-001	• Hose-No Ends	1
29	87145	• Clamp T-Bolt	4
30	86911-009	• Stem, 2 ½"	2
-31	85659-014	• Assembly, Hydraulic Hose	1
-32	85664-008	• Assembly, Hydraulic Hose	1
-33	85657-001	• Assembly, Hydraulic Hose	1
-34	85667-004	• Assembly, Hydraulic Hose	1
-35	BW10405	• Assembly, Hydraulic Hose	1
-36	87415-001	• Union Male JIC MJ-MJ16-12	1
-37	87415-002	• Union Male JIC MJ-MJ16-16	1
-38	BW10229	• Conical Seal Size-12	4
-39	BW10230	• Conical Seal Size-16	6
-40	10282	• Plug, Pipe-1"	2
-41	801937	• Plug, Flange 2" Code 61	1
-42	86728-032	• Elbow, MB-MJ90-24-16	1
DASH (-) ITEM NOT ILLUSTRATED			

REVISION:



## TANK INSTALLATION

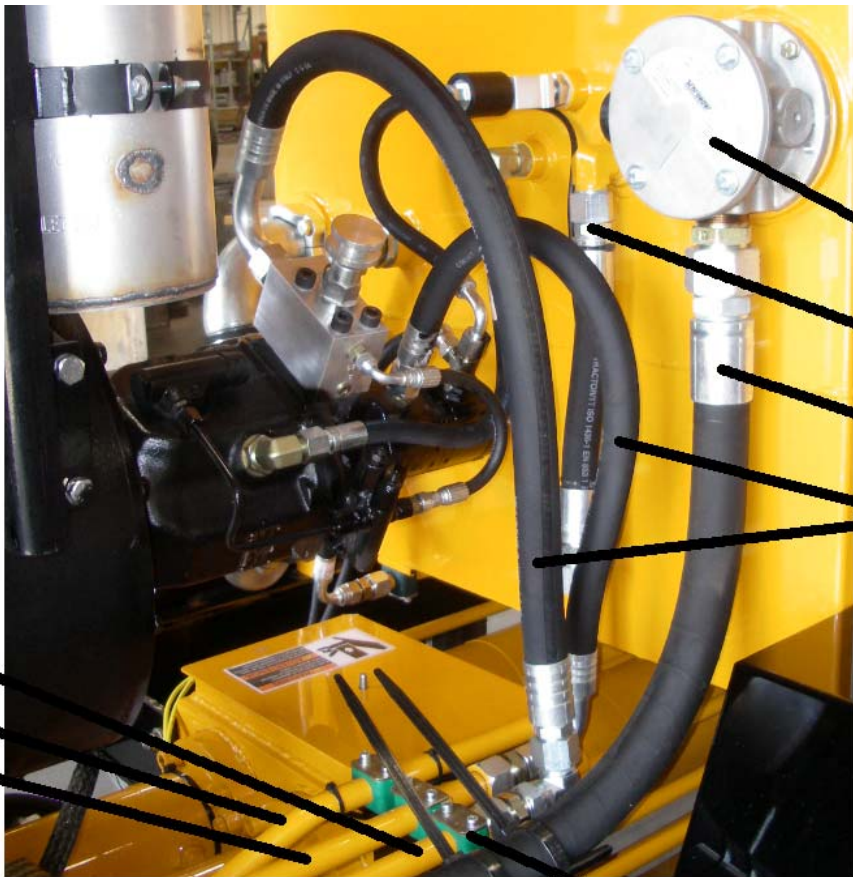

9REF

13

12

14

23

25

24

21,22



# TANK INSTALLATION

ITEM NO.	REED'S PARTS NO.	DESCRIPTION					QTY
		1	2	3	4	5	
-1	BW43020	Hydraulic/Fuel Group (See Group 10, Figure 01 for NHA)					Ref
-2	BW10397	• Assembly, A-Series Hydraulic / Fuel Tank					1
3	801025	• • Cock, ¼ Drain					2
4	74509	• • Gauge, Sight and Temperature					1
5	74508	• • Breather, Filler with Cap					1
6	BW10386	• • Weldment, A-Series Hydraulic / Fuel Tank					1
7	BW10256	• • • Cap, Filler					1
8	BW10171	• • • Kit, 12 Inch End Cover					1
9	BW10027	RETURN FILTER, HOUSING/ELEMENT/GAUGE					1
10	BW10106	• • • Element, Filter					1
11		• • • Gauge, Filter					1
12	BW10162	• Assembly, Hydraulic Hose					1
13	BW10046	• Assembly, Return Line Hydraulic Hose					1
14	BW10047	• Assembly, Main Pump Hydraulic Hose					2
15	BW10051	• Assembly, Hydraulic Hose					2
16	802289	• Clamp, Worm					2
17	801978	• Tubing, Clear PVC					1
18	BW10049	• Assembly, Swing Cylinder Hydraulic Hose					2
19	BW10154	• Assembly, Swing Cylinder Hydraulic Tube					2
20	801902-006	• Clamp, Tube					4
21	801902-001	• Nut, Tube Clamp Tee					10
22	801902-007	• Clamp, Tube					6
23	BW10150	• Assembly, Main Pump Pressure Hydraulic Tube					1
24	BW10403	• Assembly, Main Pump Pressure Hydraulic Tube					1
25	BW10153	• Assembly, Return Line Hydraulic Tube					1
26	86264-005	• Split Flange					1
27	86264-006	• Split Flange					1
28	85661-001	• Hose-No Ends					1
29	87145	• Clamp T-Bolt					4
30	86911-009	• Stem, 2 ½"					2
-31	85659-014	• Assembly, Hydraulic Hose					1
-32	85664-008	• Assembly, Hydraulic Hose					1
-33	85657-001	• Assembly, Hydraulic Hose					1
-34	85667-004	• Assembly, Hydraulic Hose					1
-35	BW10405	• Assembly, Hydraulic Hose					1
-36	87415-001	• Union Male JIC MJ-MJ16-12					1
-37	87415-002	• Union Male JIC MJ-MJ16-16					1
-38	BW10229	• Conical Seal Size-12					4
-39	BW10230	• Conical Seal Size-16					6
-40	10282	• Plug, Pipe-1"					2
-41	801937	• Plug, Flange 2" Code 61					1
-42	86728-032	• Elbow, MB-MJ90-24-16					1
DASH (-) ITEM NOT ILLUSTRATED							

REVISION:

THIS PAGE INTENTIONALLY LEFT BLANK.

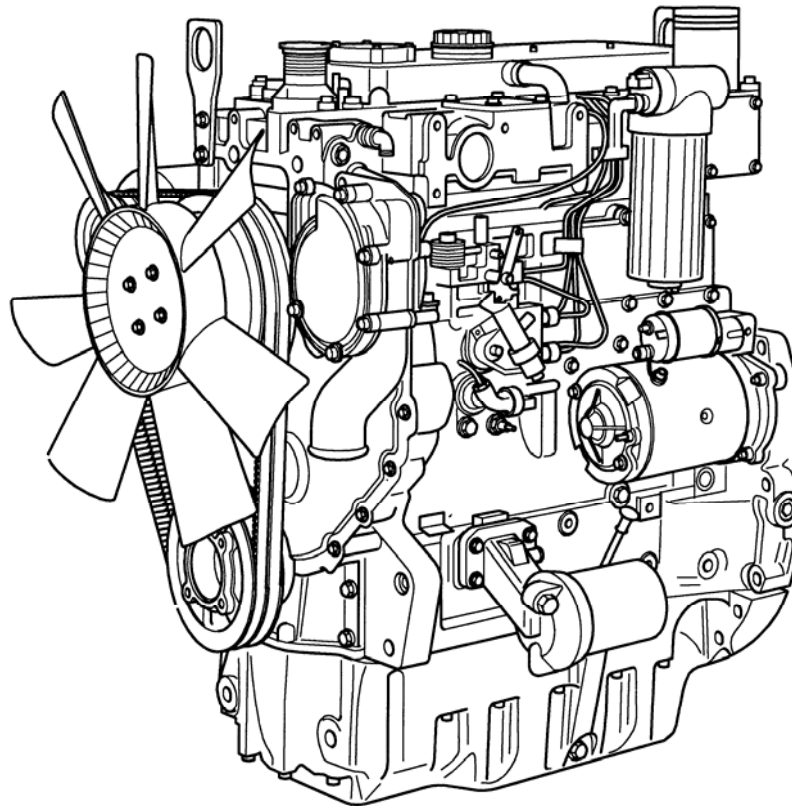

**REED** TRAILER MOUNTED CONCRETE PUMP MODEL **A40** ILLUSTRATED PARTS MANUAL GROUP 40 POWER TRAIN INSTALLATION CONTAINS THE FOLLOWING FIGURES:

- |                  |                                |
|------------------|--------------------------------|
| <b>FIGURE 00</b> | TABLE OF CONTENTS              |
| <b>FIGURE 01</b> | POWER TRAIN INSTALLATION       |
| <b>FIGURE 02</b> | BATTERY MOUNTING ASSEMBLY      |
| <b>FIGURE 03</b> | HYDRAULIC PUMPS ASSEMBLY       |
| <b>FIGURE 04</b> | MAIN PUMP ASSEMBLY             |
| <b>FIGURE 05</b> | DOUBLE AUXILIARY PUMP ASSEMBLY |



# POWER TRAIN INSTALLATION

A40  
PARTS  
GROUP 40  
FIGURE 01  
PAGE 01

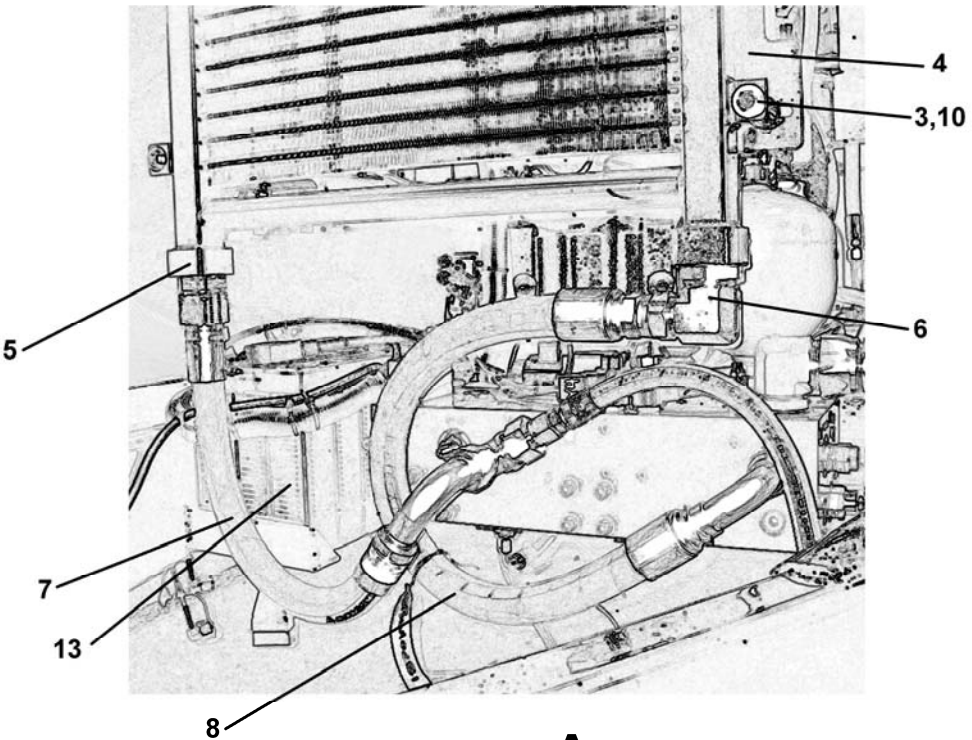
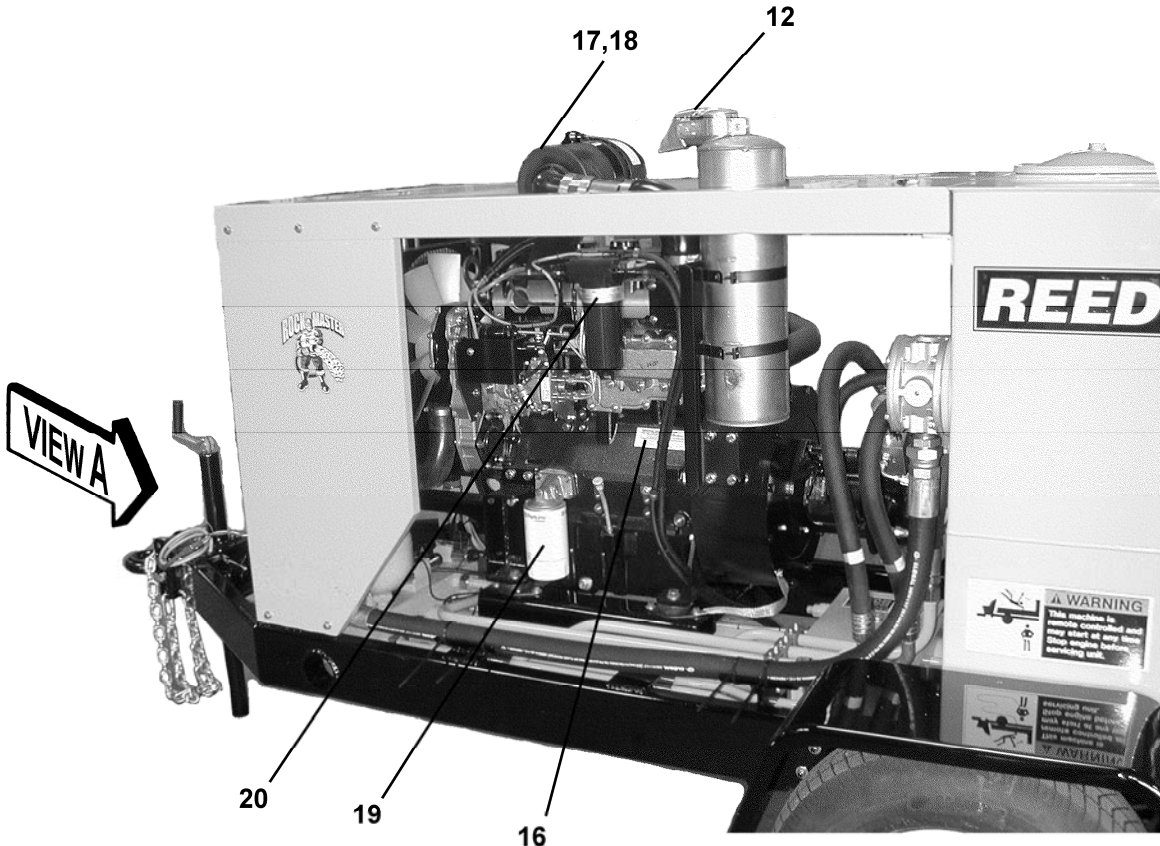

**VIEW A**  
(WITH COVER REMOVED)

REVISION:





# POWER TRAIN INSTALLATION

**A40**  
**PARTS**  
GROUP 40  
FIGURE 01  
PAGE 02

ITEM NO.	REED'S PARTS NO.	DESCRIPTION	QTY
1	BW31050	Installation, Power Train (See Group 10, Figure 01 for NHA)	Ref
2	BW10277	Cooler, Oil	1
3	BW10289	Spacer, Oil Cooler Mount	4
4	BW10278	Bracket, Oil Cooler	2
5	86900-031	Adaptor, MB-MJ-20-20	1
6	86728-026	Elbow, MB-MJ90-20-16	1
7	BW10280	Hose, 16GMV+ -20FJX-16FJX90S-24"	1
8	BW10281	Hose, 16GMV+ -20FJX-16FJX90S-36"	1
-9	BW10179	Safety Plate, Exhaust Pipe	1
10A	80043	Flatwasher-3/8 USS	16
-10B	80072	Lockwasher-3/8	8
-10C	80003	Nut, Hex 3/8-16	4
-11	78213	Clamp	1
12	70849	Cap, Rain	1
13	40-02	Assembly, Battery Mounting (See Group 40, Figure 02 for DET)	1
-14	10577	Clamp, Hose	2
-15	77347A	Hose, 13ft FT Fuel	1
16	BW10039-2	Assembly, Engine (See Vendor Section, Figure 01 for REF)	1
17	BW10330	Element, Air Filter, Primary	1
18	BW10331	Element, Air Filter, Safety	1
19	BW10332	Filter, Oil	1
20	BW10333	Filter, Fuel	1
21	40-03	Assembly, Hydraulic Main Pump (See Group 40, Figure 03 for REF) (Also See Vendor Section, Figure 02 for REF)	1
22	40-03	Assembly, Hydraulic Gear Pump (See Group 40 Figure 03 for REF) (Also See Vendor Section, Figure 03 for REF)	1
-23	73269	Strap, Ground	1
-24	BW10322	Assembly, Engine Wiring Harness (See Schematic Section, Page 05 for REF) DASH (-) ITEM NOT ILLUSTRATED	1

REVISION:



# BATTERY MOUNTING ASSEMBLY

A40  
PARTS  
GROUP 40  
FIGURE 02  
PAGE 01

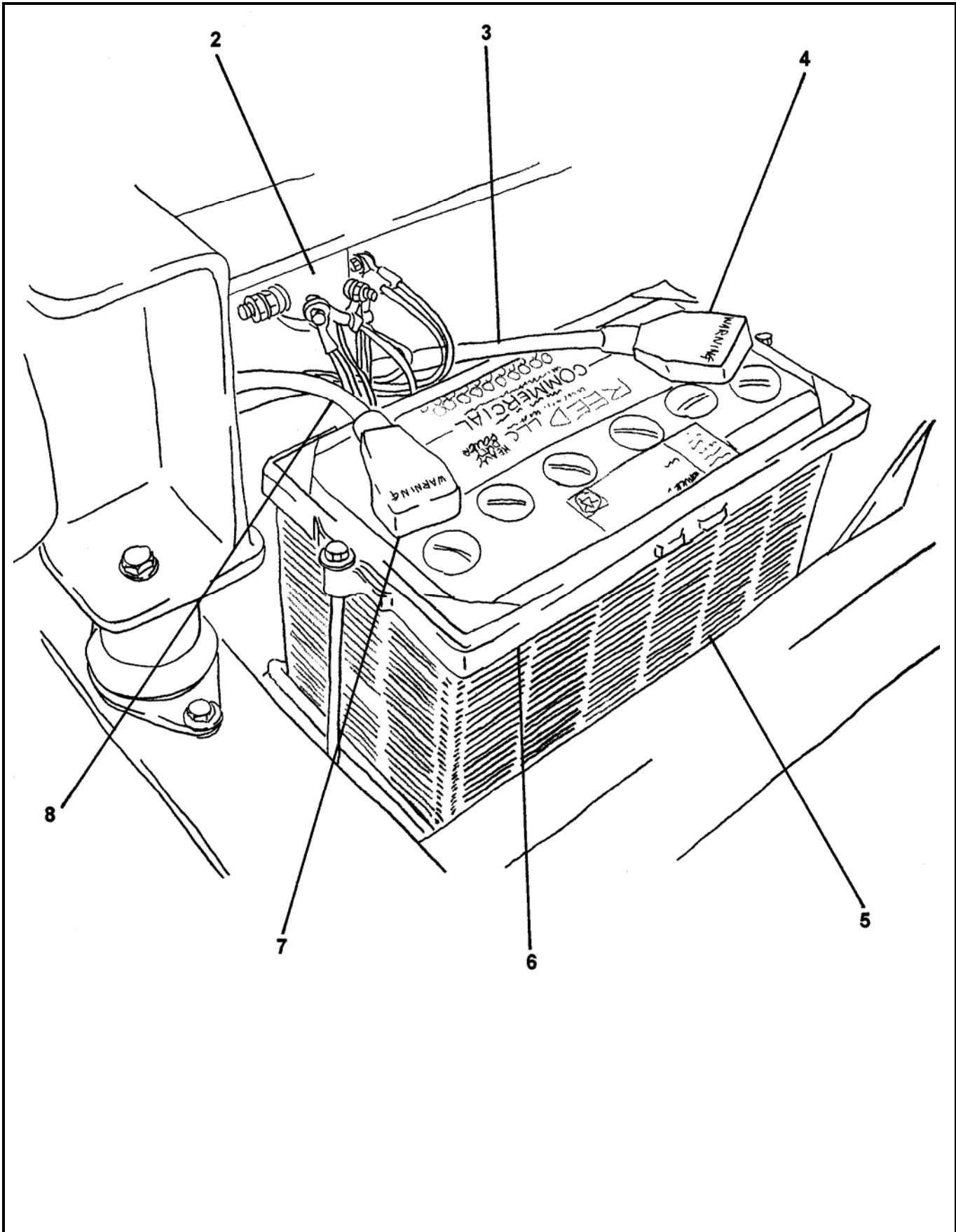

REVISION:



# BATTERY MOUNTING ASSEMBLY

**A40**  
**PARTS**  
GROUP 40  
FIGURE 02  
PAGE 02

ITEM NO.	REED'S PARTS NO.	DESCRIPTION	QTY
		1 2 3 4 5	
-1	40-02	Assembly, Battery Mounting (See Group 40, Figure 01 for NHA)	Ref
2	85348	• Connector, SPNO 12 VDC	1
3	72014	• Cable, 36 Inch Long Battery Top (Red)	1
4	77719	• Cover, Positive Battery (Red)	1
5	77075	• Battery, 12 VDC	1
6	72945	• Holder, Battery Down	1
7	77720	• Cover, Negative Battery (Black)	1
8	75116	• Cable, Negative Battery (Black)	1

DASH (-) ITEM NOT ILLUSTRATED

REVISION:



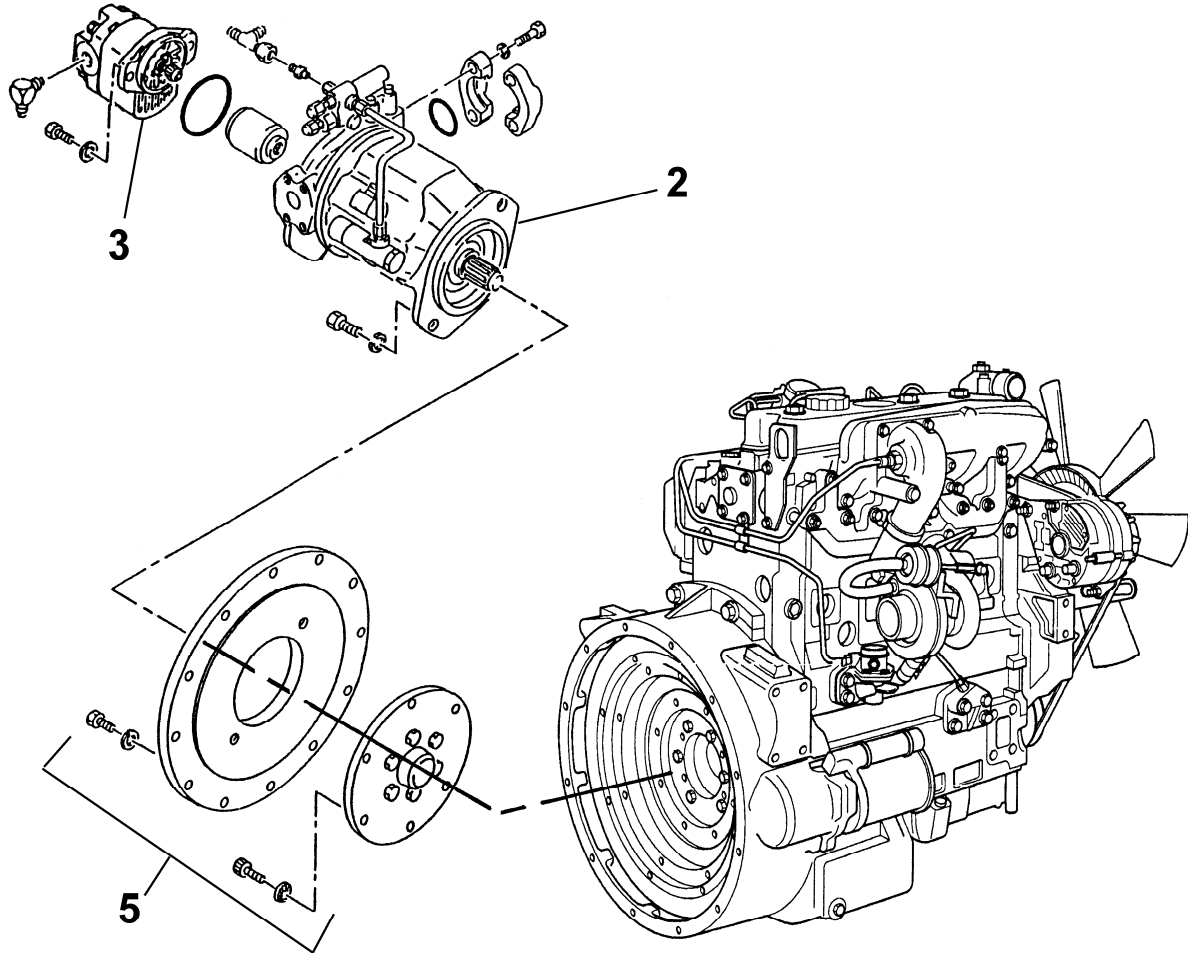

**PERKINS DIESEL ENGINE**  
BW10039-2 (REF)



# HYDRAULIC PUMPS ASSEMBLY

**A40**  
**PARTS**  
GROUP 40  
FIGURE 03  
PAGE 02

ITEM NO.	REED'S PARTS NO.	DESCRIPTION					QTY
		1	2	3	4	5	
-1	40-03	Assembly, Hydraulic Pumps (See Group 40, Figure 01 for NHA)					Ref
2	85124-001	• Pump, Main					1
3	87153-001	• Pump, Single Auxiliary					1
-4	85125	• Valve, Flow Control-Main Pump					1
5	85126	• Pump Drive					1
6	-	•					-
7	-	•					-
8	-	•					-

REVISION:



# MAIN PUMP ASSEMBLY

A40  
PARTS  
GROUP 40  
FIGURE 04  
PAGE 01

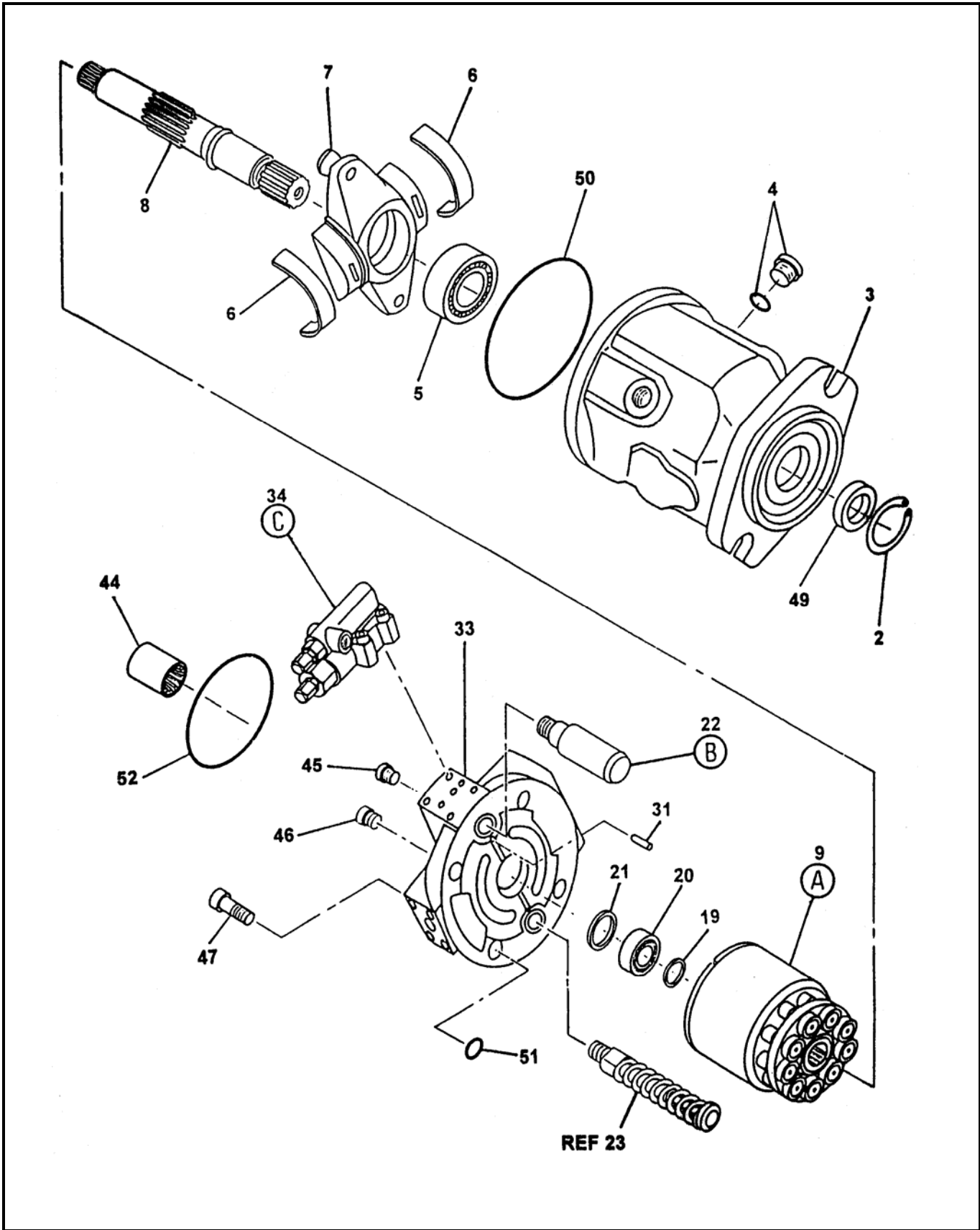

REVISION:



# MAIN PUMP ASSEMBLY

**A40**  
**PARTS**  
GROUP 40  
FIGURE 04  
PAGE 02

ITEM NO.	REED'S PARTS NO.	DESCRIPTION	QTY
		1 2 3 4 5	
-1	85124-001	Assembly, Main Pump (See Group 40, Figure 02 for NHA) (Also See Vendor Section, Figure 02 for REF)	Ref
2		• V-Ring, Seeger	1
3		• Housing, Pump	1
4		• Plug, O-Ring	1
5		• Bearing, Tapered Roller	1
6		• Bearing, Cradle	2
7		• Assembly, Cradle	1
8		• Shaft, Drive	1
9		• Assembly, Rotary	1
23		• Assembly, Piston Control	1
33		• Block	1
34		• Assembly, Control Valve	1
44		• Coupling	1
45		• Plug	1
46		• Plug	1
47		• Screw, Cap	2
-48		• Kit, Seal	1
49		•• Seal, Shaft	1
50		•• O-Ring	1
51		•• O-Ring	1
52		•• O-Ring	1

REVISION:



# MAIN PUMP ASSEMBLY

A40  
PARTS  
GROUP 40  
FIGURE 04  
PAGE 03

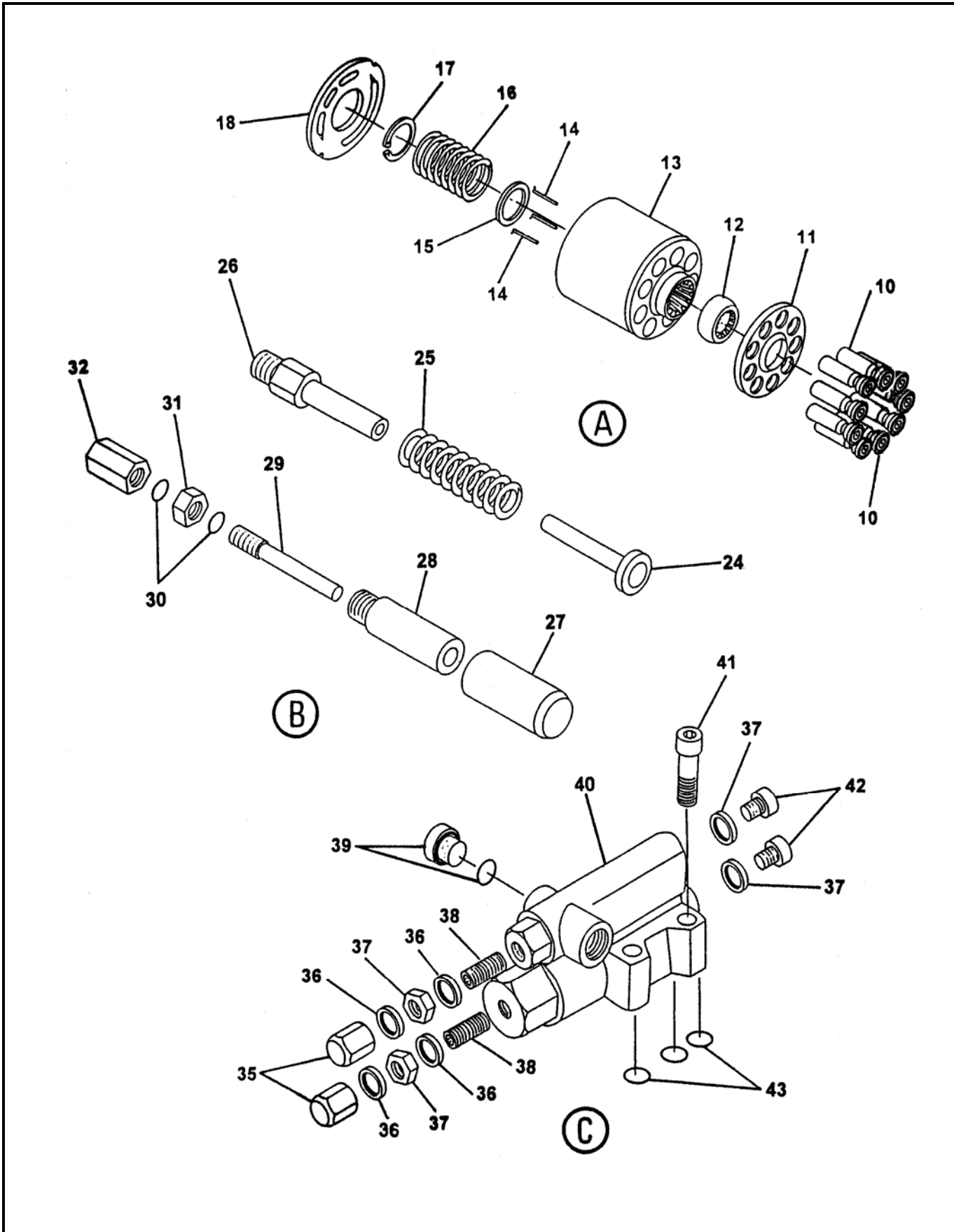

REVISION:



# MAIN PUMP ASSEMBLY

**A40**  
**PARTS**  
GROUP 40  
FIGURE 04  
PAGE 04

ITEM NO.	REED'S PARTS NO.	DESCRIPTION					QTY
		1	2	3	4	5	
-9		• Assembly, Rotary					1
10		• • Piston					9
11		• • Plate, Retaining					1
12		• • Ball, Retaining					1
13		• • Barrel					1
14		• • Pin, Pressure					3
15		• • Disc, Retaining Clip					1
16		• • Spring					1
17		• • Ring, Retaining					1
18		• • Plate, Lens					1
-23		• Assembly, Piston Control					1
24		• • Piston, Counter					1
25		• • Spring					1
26		• • Guide, Counter Piston					1
27		• • Piston, Counter					1
28		• • Guide, Counter Piston					1
29		• • Screw, Max Volume Adjustment					1
30		• • O-Ring					2
31		• • Nut, Lock					1
32		• • Nut, Acorn					1
-34		• Assembly, Control Valve					1
35		• • Nut, Acorn					2
36		• • O-Ring					3
37		• • Nut, Jam					2
38		• • Screw, Adjusting					2
39		• • Plug, O-Ring					1
40		• • Body, Control Valve					1
41		• • Screw, Cap (attaching parts)					4
42		• • Plug					2
43		• • O-Ring					3

DASH (-) ITEM NOT ILLUSTRATED

REVISION:





# DOUBLE AUXILIARY PUMP ASSEMBLY

A40  
PARTS  
GROUP 40  
FIGURE 05  
PAGE 01

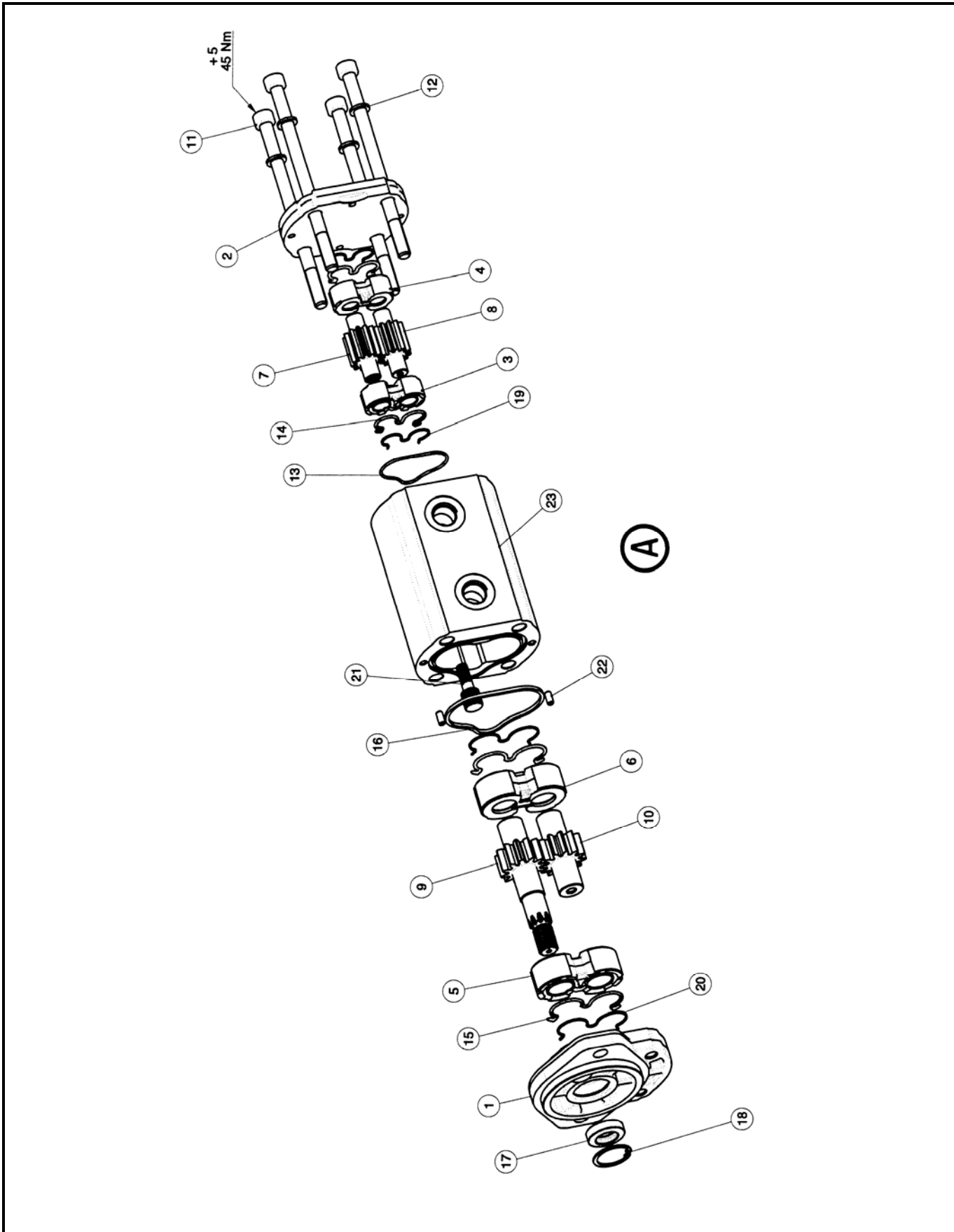

REVISION:



# DOUBLE AUXILIARY PUMP ASSEMBLY

**A40**  
**PARTS**  
GROUP 40  
FIGURE 05  
PAGE 02

ITEM NO.	REED'S PARTS NO.	DESCRIPTION	QTY
		1 2 3 4 5	
A	87153-001	Assembly, Double Auxiliary Pump (See Group 40, Figure 02 for NHA) (Also See Vendor Section, Figure 02 for REF)	Ref
1		• Cover, Front	1
2		• Cover, Twin Rear	1
3		• Plate, Thrust	1
4		• Plate, Thrust	1
5		• Plate, Thrust	1
6		• Plate, Thrust	1
7		• Gear, Drive	1
8		• Gear, Driven	1
9		• Shaft, Drive	1
10		• Shaft, Driven	1
11		• Screw	4
12		• Washer	4
13		• O-Ring	1
14		• Seal	2
15		• Seal	2
16		• Plate, Seal	1
17		• Seal, Shaft	1
18		• Ring	1
19		• Plate, Anti-Intrusion	2
20		• Ring, Back-Up	2
21		• Hub	1
22		• Pin, Dowel	2
23		• Body	1

REVISION:



**TRAILER MOUNTED PUMP MODEL A40  
ILLUSTRATED PARTS MANUAL**

**A40**  
**PARTS**  
GROUP 40  
FIGURE 06  
PAGE 01

THIS PAGE INTENTIONALLY LEFT BLANK.

**REED** TRAILER MOUNTED CONCRETE PUMP **MODEL A40** ILLUSTRATED PARTS MANUAL **GROUP 50 CONTROLS INSTALLATION** CONTAINS THE FOLLOWING FIGURES:

- FIGURE 00** TABLE OF CONTENTS
- FIGURE 01** CONTROLS INSTALLATION
- FIGURE 02** CONTROL BOX ASSEMBLY
- FIGURE 03** CABLE REMOTE CONTROL ASSEMBLY
- FIGURE 04** RADIO REMOTE CONTROL ASSEMBLY



## CONTROL INSTALLATION

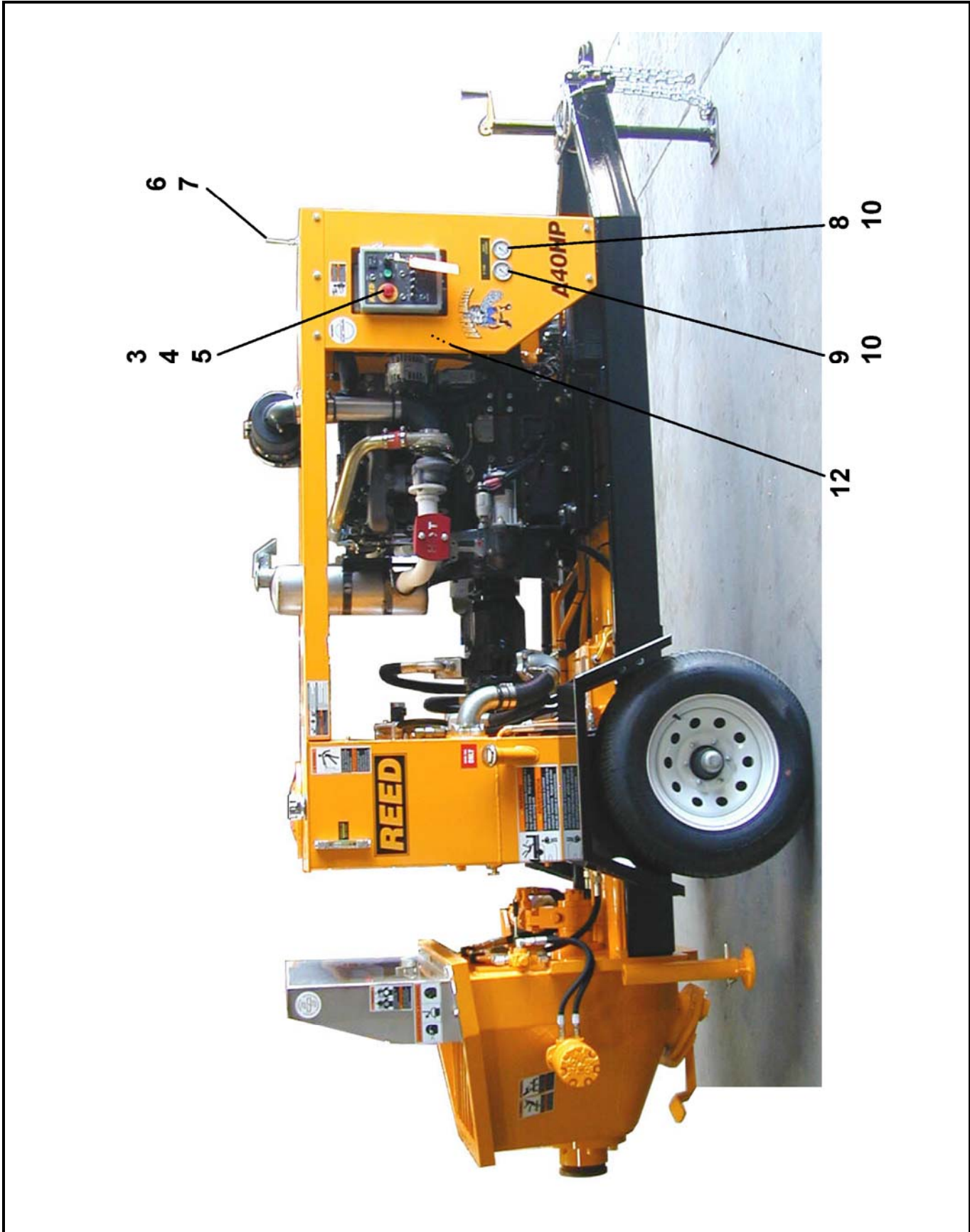

REVISION:



# CONTROL INSTALLATION

ITEM NO.	REED'S PARTS NO.	DESCRIPTION	QTY
		1 2 3 4 5	
-1	50-01	Installation, Control (See Group 10, Figure 01 for NHA)	Ref
2	BW10013	• Assembly, Cable Remote Control (See Group 50, Figure 03 for DET)	1
3	BW10343	• Assembly, Control Box (See Group 50, Figure 03 for DET)	1
4	73748	• Bumper, Control Box	4
5	72862	• Gauge, Proximity Sensor Setting	1
6	BW10132	• Radio Remote Control Kit-Kartech (Optional Item) (See Group 50, Figure 04 for DET)	1
7	BW10188	• Radio Remote Control Kit-Remtron (Optional Item) (See Group 50, Figure 04 for DET)	1
-7A	BW10188-001	• Radio Remote Control Kit-Base (Optional Item)	1
8	74562	• Gauge, 6,000 PSI Hydraulic	1
9	70366	• Gauge, 3,000 PSI Hydraulic	1
10	78594	• Adapter, Minicheck Gauge	2
-11	BW10318	• Hose, 48 Inch-90 Degree Minicheck	2
12	800347	• Horn, 12 V	1
DASH (-) ITEM NOT ILLUSTRATED			

REVISION:





# CABLE REMOTE CONTROL ASSEMBLY

A40  
PARTS  
GROUP 50  
FIGURE 02  
PAGE 01



REVISION:



**CABLE REMOTE CONTROL ASSEMBLY**

**A40**  
**PARTS**  
GROUP 50  
FIGURE 02  
PAGE 02

THIS GROUP 50, FIGURE 02, PARTS NUMBER BW10013,  
**CABLE REMOTE CONTROL ASSEMBLY,**  
DETAIL PARTS LIST IS NOT AVAILABLE THIS REVISION.

REVISION:



# CONTROL BOX ASSEMBLY

A40  
PARTS  
GROUP 50  
FIGURE 03  
PAGE 01

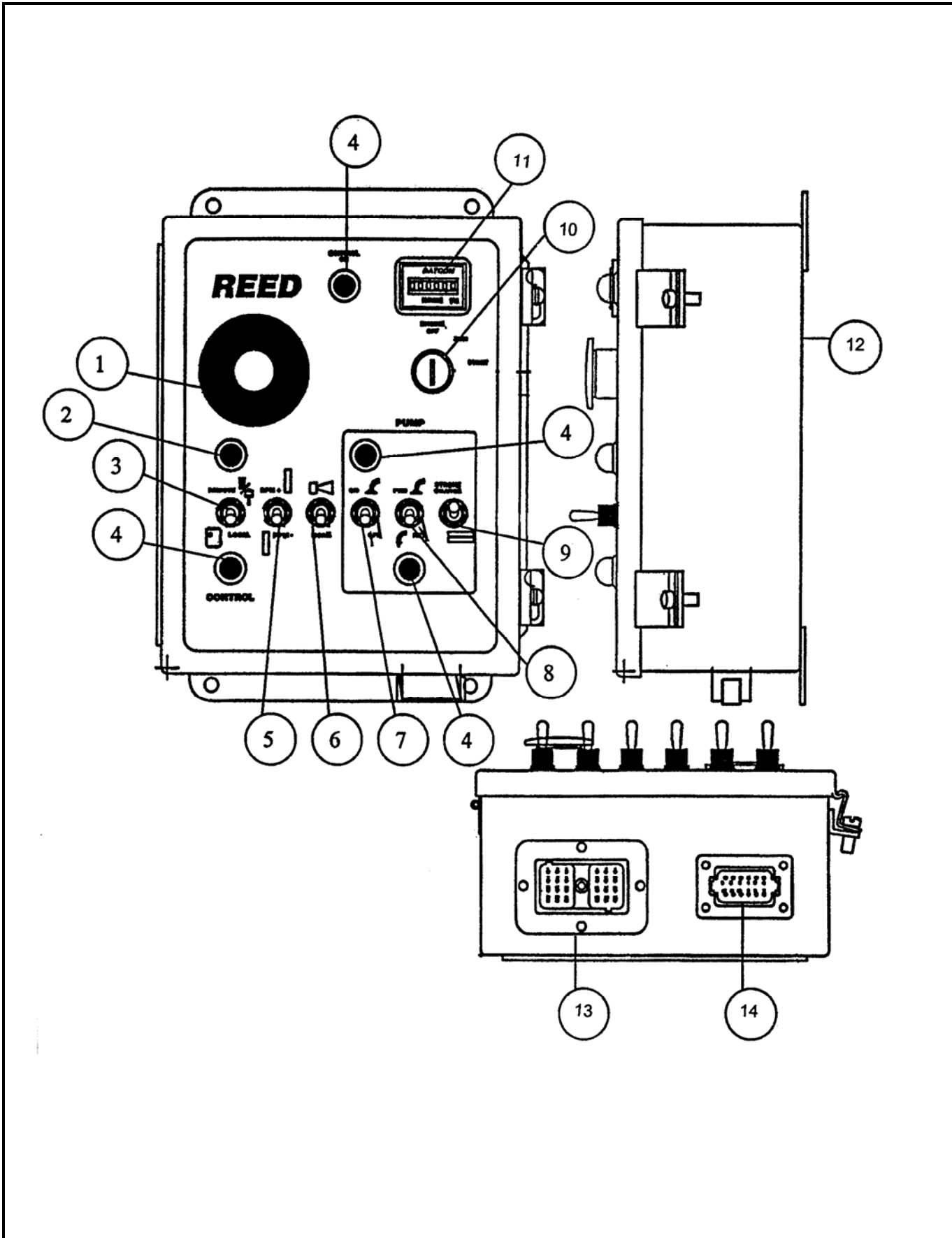

REVISION:



# CONTROL BOX ASSEMBLY

**A40**  
**PARTS**  
GROUP 50  
FIGURE 03  
PAGE 02

ITEM NO.	REED'S PARTS NO.	DESCRIPTION	QTY
		1 2 3 4 5	
1	BW10208	• E-Stop Light (Power Supply)	1
2	BW10214	• Lens, Amber	1
3	BW10223	• SPST Toggle Switch On-On	1
4	BW10215	• Lens, Green	1
5	BW10205	• SPDT Momentary Switch	1
6	BW10206	• SPDT Momentary Switch	1
7	BW10207	• SPST Toggle Switch	1
8	BW10207	• SPST Toggle Switch	1
9	BW10206	• SPDT Momentary Switch	1
10	BW10204	• SW, Key Switch	1
11	BW10212	• Hour Meter-Mini	1
12	BW10203	• 10x8x4 Steel CH Enclosure	1
13	BW10217	• Connector, DRC12-24PA	1
14	BW10218	• Connector, DT04-12PA-L012, 12 Pin EMT	1
-15	BW10209	• Mushroom Head Maintained Button (Ref-BW10208 Red Light Housing)	1
-16	BW10211	• LGT, Mini Bayonet Red (Ref-BW10208 and BW10209)	1
-17	BW10213	• Light Socket (Ref-BW10214 and BW10215)	5
-18	BW10216	• Light Bayonet 14V (Ref-BW10213,BW10214 and BW10215)	5
-19	BW10219	• Connector 12 Pin, Gasket (Ref-BW10218)	1
-20	BW10220	• Connector 24in, Gasket (Ref-BW10217)	1

ITEM (-) NOT ILLUSTRATED

REVISION:



# CONTROL BOX ASSEMBLY

A40  
PARTS  
GROUP 50  
FIGURE 03  
PAGE 03

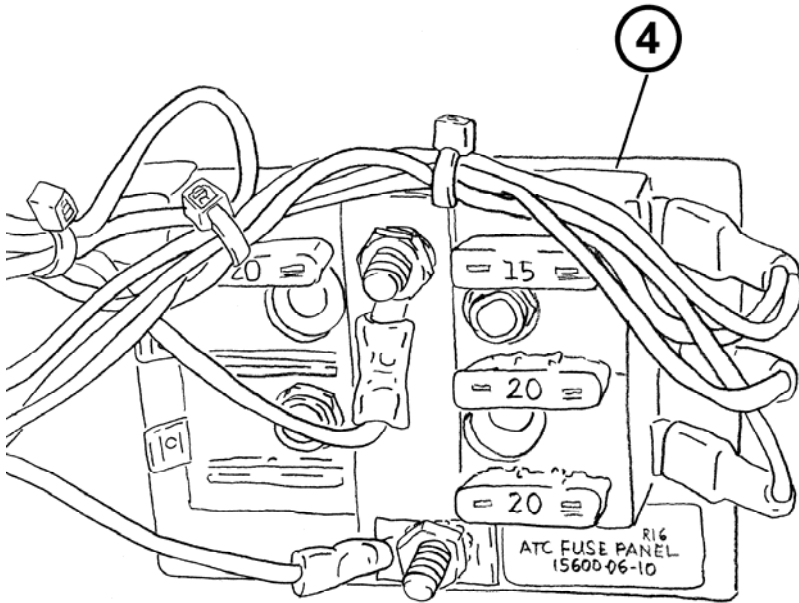
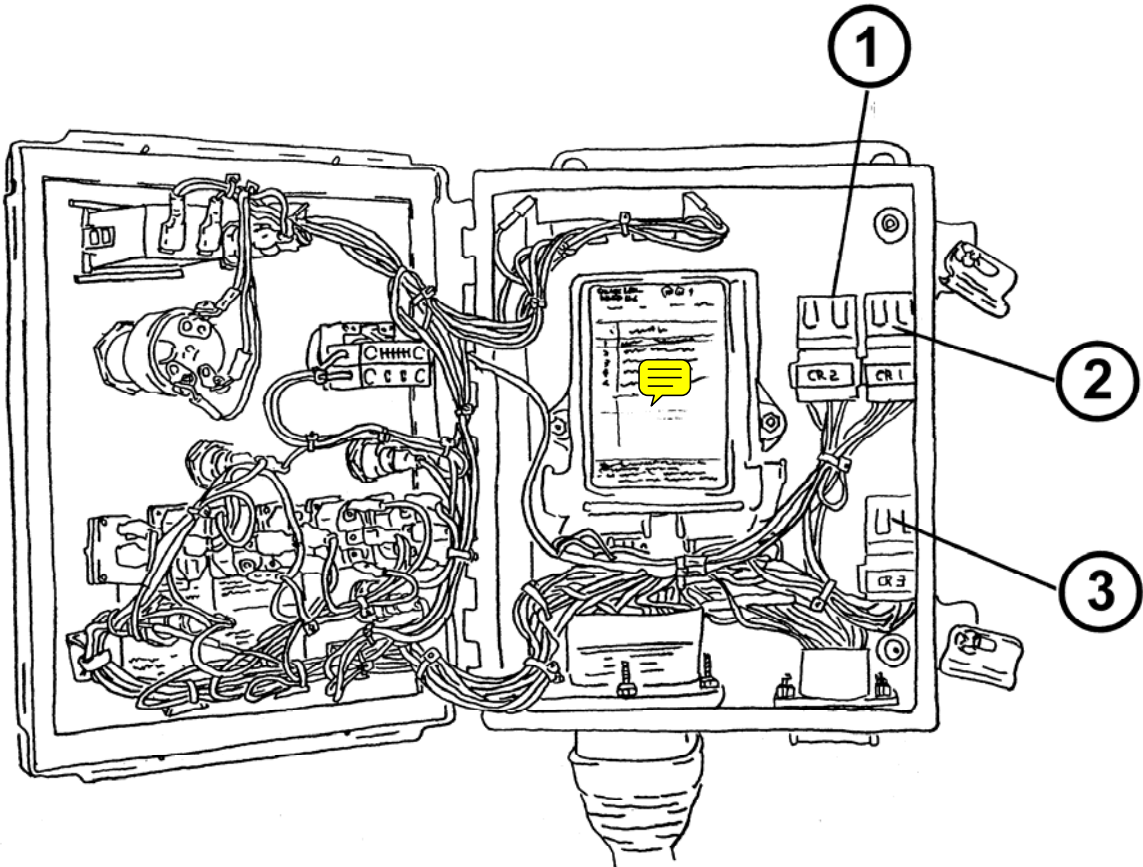

REVISION:



# CONTROL BOX ASSEMBLY

**A40**  
**PARTS**  
GROUP 50  
FIGURE 03  
PAGE 04

ITEM NO.	REED'S PARTS NO.	DESCRIPTION	QTY
		1 2 3 4 5	
1	BW10222	• Relay, Diode Suppress (Note: Same Part# For Items 1,2, &3)	1
2	BW10222	• Relay, Diode Suppress (Note: Same Part# For Items 1,2, &3)	1
3	BW10222	• Relay, Diode Suppress (Note: Same Part# For Items 1,2, &3)	1
4	BW10227	• Fuse, Block GNG 6F	1



REVISION:





# OPTIONAL RADIO REMOTE CONTROL ASSEMBLY

**A40**  
**PARTS**  
GROUP 50  
FIGURE 04  
PAGE 01

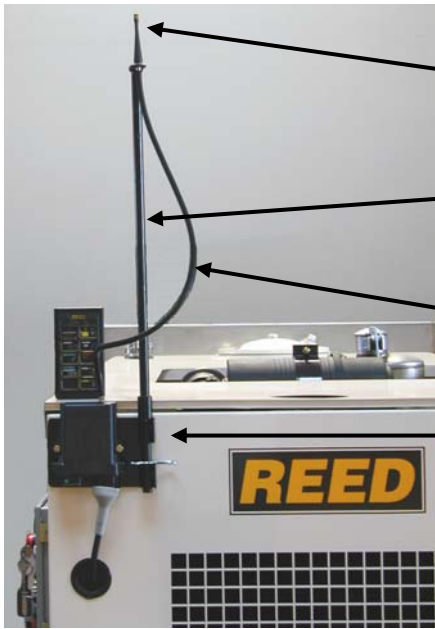

**BW10132 KAR-TECH  
RADIO REMOTE KIT**

- 1
- 2
- 3
- 4
- 5
- 6

**BW10247 DECAL**



- 7
- 8



**BW10188 REMTRON  
RADIO REMOTE KIT**

REVISION:



# OPTIONAL RADIO REMOTE CONTROL ASSEMBLY

**A40**  
**PARTS**  
GROUP 50  
FIGURE 04  
PAGE 02

ITEM NO.	REED'S PARTS NO.	DESCRIPTION					QTY
		1	2	3	4	5	
1	BW10196	• Antenna Support					1
2	BW10194	• Rod, Antenna					1
3	BW10201	• Antenna Cable-27"					1
4	BW10012	• Radio Remote Receiver-Kartech					1
5	BW10200	• Plate Weldment, Rod Assembly Support					1
6	BW10202	• Hair Pin					1
7	BW10011	• Radio Remote Transmitter-Kartech					1
8	BW10192	• Holster for Kartech Radio Transmitter					1
9	BW10190	• Radio Remote Receiver-Remtron					1
10	BW10191	• Holster Shoulder Strap for Remtron Transmitter					1
11	BW10189	• Transmitter for Remtron Radio					1
12	NA	• Antenna-See BW10188					1
13	NA	• Coax Cable-See BW10188					1
-14	800418	• Lanyard for BW10202					1
-15	BW10195	• Tab, Antenna Support					1
-16	BW10197	• Tube, Rod Assembly Support					1
-17	BW10198	• Tube, Rod Assembly Support					1
-18	BW10199	• Plate, Rod Assembly Support					1
-19	BW10200	• Plate Weldment, Rod Assembly Support					1
-20	BW10176	• Bracket, Mounting-Remtron Radio					1
-21	-	•					-

DASH (-) ITEM NOT ILLUSTRATED

REVISION:

THIS PAGE INTENTIONALLY LEFT BLANK.

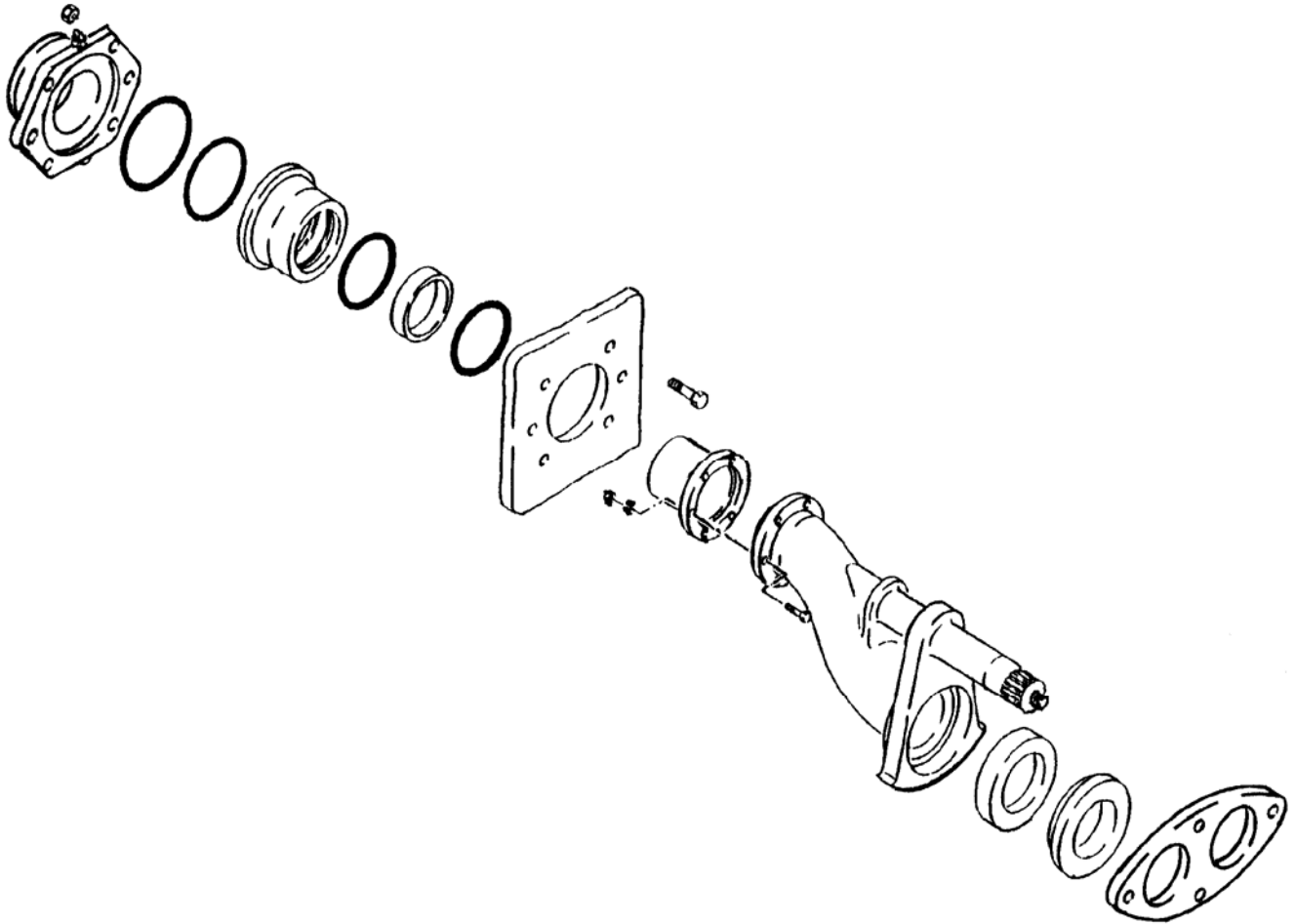

**REED TRAILER MOUNTED CONCRETE PUMP MODEL A40 ILLUSTRATED PARTS MANUAL GROUP 60 PUMPING TRAIN INSTALLATION CONTAINS THE FOLLOWING FIGURES:**

- FIGURE 00** TABLE OF CONTENTS
- FIGURE 01** PUMPING TRAIN INSTALLATION
- FIGURE 02** SWING VALVE ASSEMBLY
- FIGURE 03** SWING RAM CYLINDER SUB-ASSEMBLY
- FIGURE 04** CONCRETE CYLINDER ASSEMBLY
- FIGURE 05** FLUSHBOX ASSEMBLY
- FIGURE 06** HYDRAULIC DRIVE CYLINDER ASSEMBLY
- FIGURE 07** DRIVE CYLINDER SUB-ASSEMBLY
- FIGURE 08** CONTROL MANIFOLD WITH CARTRIDGE ASSEMBLY
- FIGURE 09** REVERSE CIRCUIT PILOTSOLENOID VALVE ASSEMBLY
- FIGURE 10** MAIN CYCLING CIRCUIT PILOT SOLENOID VALVE ASSEMBLY

## PUMPING TRAIN INSTALLATION

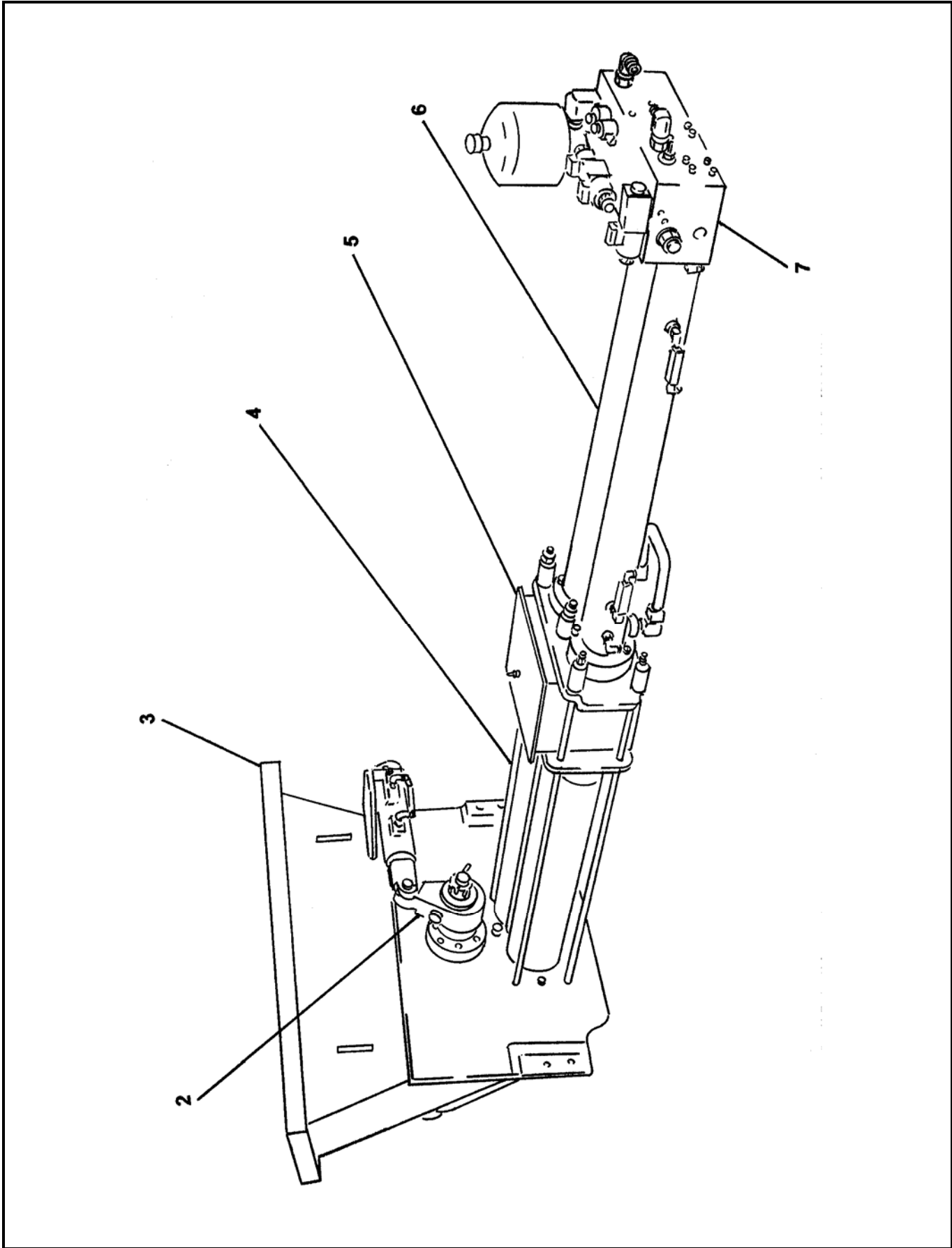

REVISION:



# PUMPING TRAIN INSTALLATION

ITEM NO.	REED'S PARTS NO.	DESCRIPTION	QTY
		1 2 3 4 5	
-1	BW28040	Assembly, Pumping Train (See Group 10, Figure 01 and Figure 03 for NHA)	Ref
2	BW26040	• Group, Swing Valve (See Group 60, Figure 02 for DET)	1
3	BW24040	• Group, Hopper (See Group 20, Figure 01 for REF)	Ref
4	BW23040	• Group, Concrete Cylinder (See Group 60, Figure 04 for DET)	1
5	BW22040	• Group, Flush Box (See Group 60, Figure 05 for DET)	1
6	BW21040	• Group, Hydraulic Drive Cylinder (See Group 60, Figure 06 for DET)	1
7	BW10395	• Assembly, Control Manifold with Cartridge (See Group 60, Figure 09 for DET)	1
		DASH (-) ITEM NOT ILLUSTRATED	

REVISION:



# SWING VALVE ASSEMBLY

A40  
PARTS  
GROUP 60  
FIGURE 02  
PAGE 01

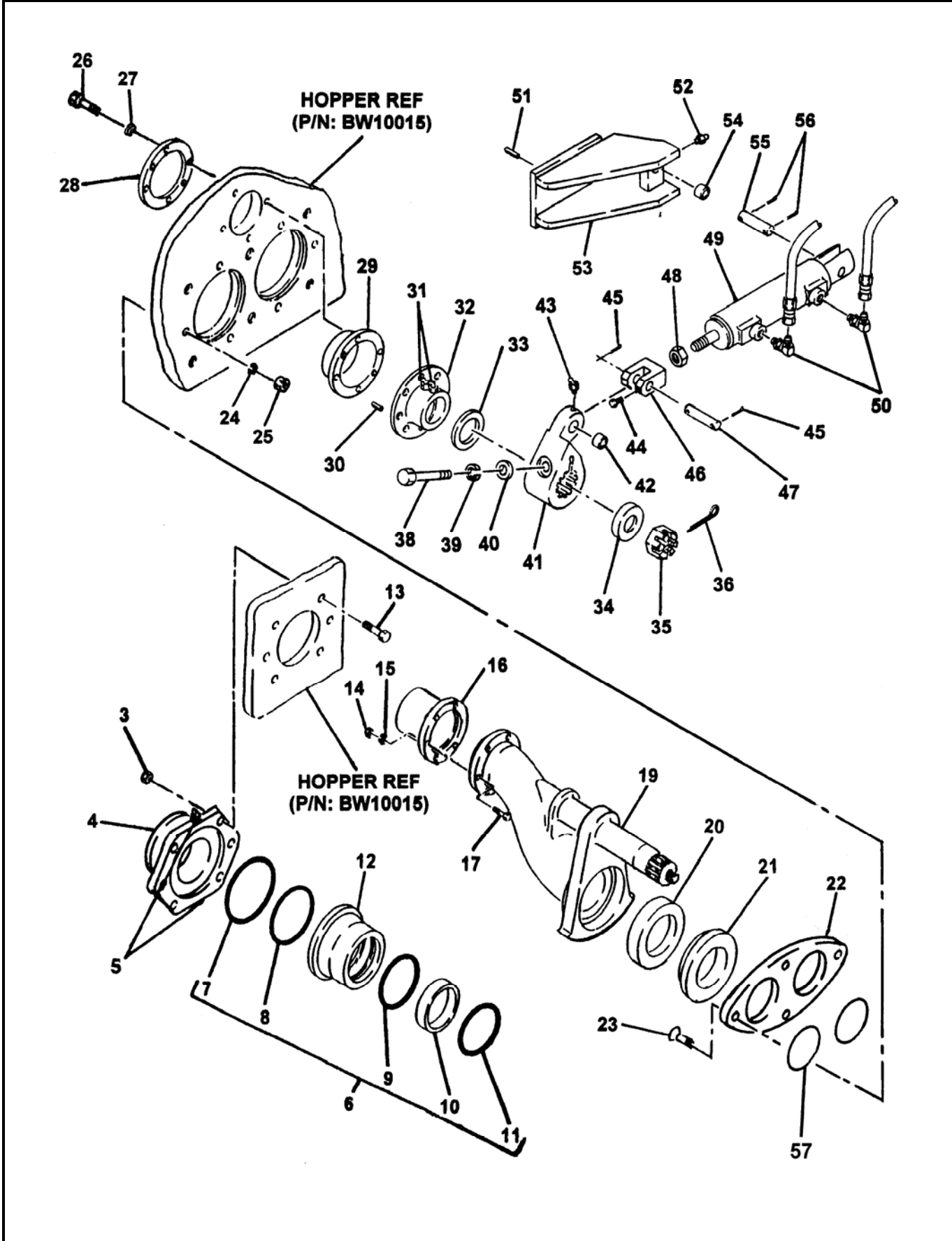

REVISION:





# SWING VALVE ASSEMBLY

**A40**  
**PARTS**  
 GROUP 60  
 FIGURE 02  
 PAGE 02

ITEM NO.	REED'S PARTS NO.	DESCRIPTION					QTY
		1	2	3	4	5	
-1	60-02	Assembly, Swing Valve (See Group 60, Figure 01 for NHA)					Ref
-2	86321	• Assembly, Outlet Group					1
3		•• Nut					6
4	70122	•• Outlet, Machine 5"					1
5		•• Fitting, Grease					2
6	79895	•• Kit, Outlet Seal					1
7	77761	••• O-Ring, Large					1
8	77762	••• O-Ring, Small					1
9	86504	••• Seal, Modified Outlet Thick					1
10	77763	••• Band, Guide					1
11	77765	••• Seal, Outlet Thick					1
12	72309	•• Housing, Outlet Seal					1
13		•• Bolt, Hex					6
14		•• Nut, Nylock (attaching parts)					6
15		•• Washer, Lock (attaching parts)					6
16	70042	•• Outlet, Chromed					1
17		•• Bolt, Hex (attaching parts)					6
-18	BW25040	• Assembly, Swing Tube Group					1
19	BW10391	•• Weldment, Swing Tube					1
20	86085	•• Seal, 6 Inch					1
21	72310	•• Ring, 6 Inch Wear					1
22	BW10382	•• Plate, Wear					1
23		•• Bolt, Flat Head					4
24		•• Washer, Lock					4
25		•• Nut, Hex					4
26		•• Bolt, Hex					6
27		•• Washer, Lock					6
28	BW10024	•• Ring, Space					1
29	85962	•• Seal, Flange Bearing					1
30		•• Pin, Dowel					1
31		•• Fitting, Grease 90					2
32	85133	•• Bearing, 3 Inch Spline Flange					1
33	85294	•• Washer, Thrust					1
34	85134	•• Spacer, Swing Tube Nut					1
35	70825	•• Nut, Swing Tube					1
36		•• Pin Cotter					1
-37	BW26040	• Assembly, Swing Tube Shift Group					1
38		•• Bolt, Hex					1
39		•• Washer, Flat					1
40		•• Washer, Lock					1
41	85131	•• Crank, 3 Inch Spline Bell					1
DASH (-) ITEM NOT ILLUSTRATED							

REVISION:



# SWING VALVE ASSEMBLY

A40  
PARTS  
GROUP 60  
FIGURE 02  
PAGE 03

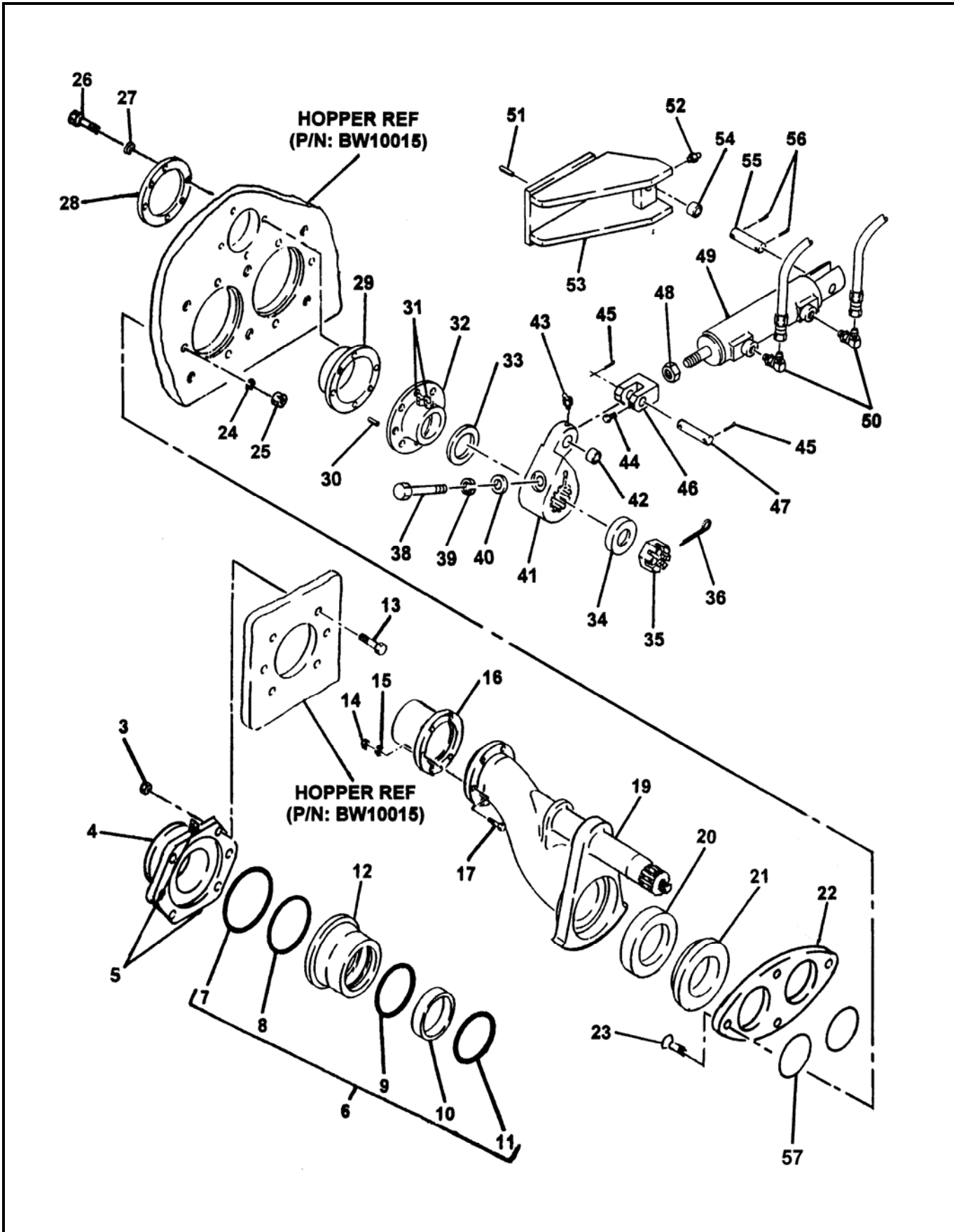

REVISION

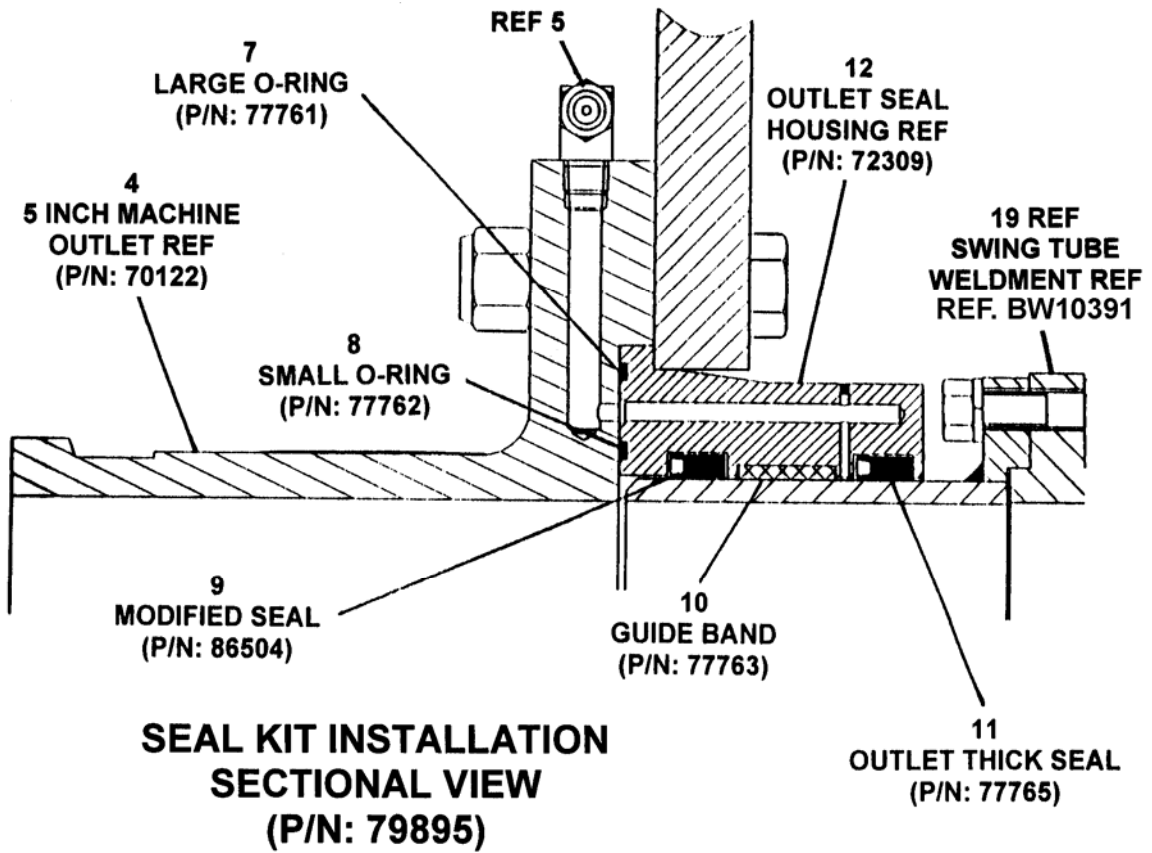

ITEM NO.	REED'S PARTS NO.	DESCRIPTION					QTY
		1	2	3	4	5	
42	85538	•••	Race, Inner				1
43		••	Fitting, Grease 90				1
44		••	Bolt, Hex				1
45		••	Pin, Cotter				2
46	86135	••	Clevis, Swing Ram Cylinder				1
47	86150	••	Pin, Clevis				1
48		••	Nut, Hex				1
49	BW10374	••	Assembly, Swing Ram Cylinder (See Group 60, Figure 03 for DET)				1
50		••	Fitting, 90				2
51	86052	••	Pin, Spring				2
52		••	Fitting, Grease STR				1
53	85947	••	Bracket, Swing Cylinder				1
54	71011	•••	Bushing, Shift Cylinder				1
55	74207	••	Pin, Clevis				1
56		••	Pin, Cotter				2
57	86086	•	Ring, Anti-Chip				1
DASH (-) ITEM NOT ILLUSTRATED							

## SWING RAM CYLINDER ASSEMBLY

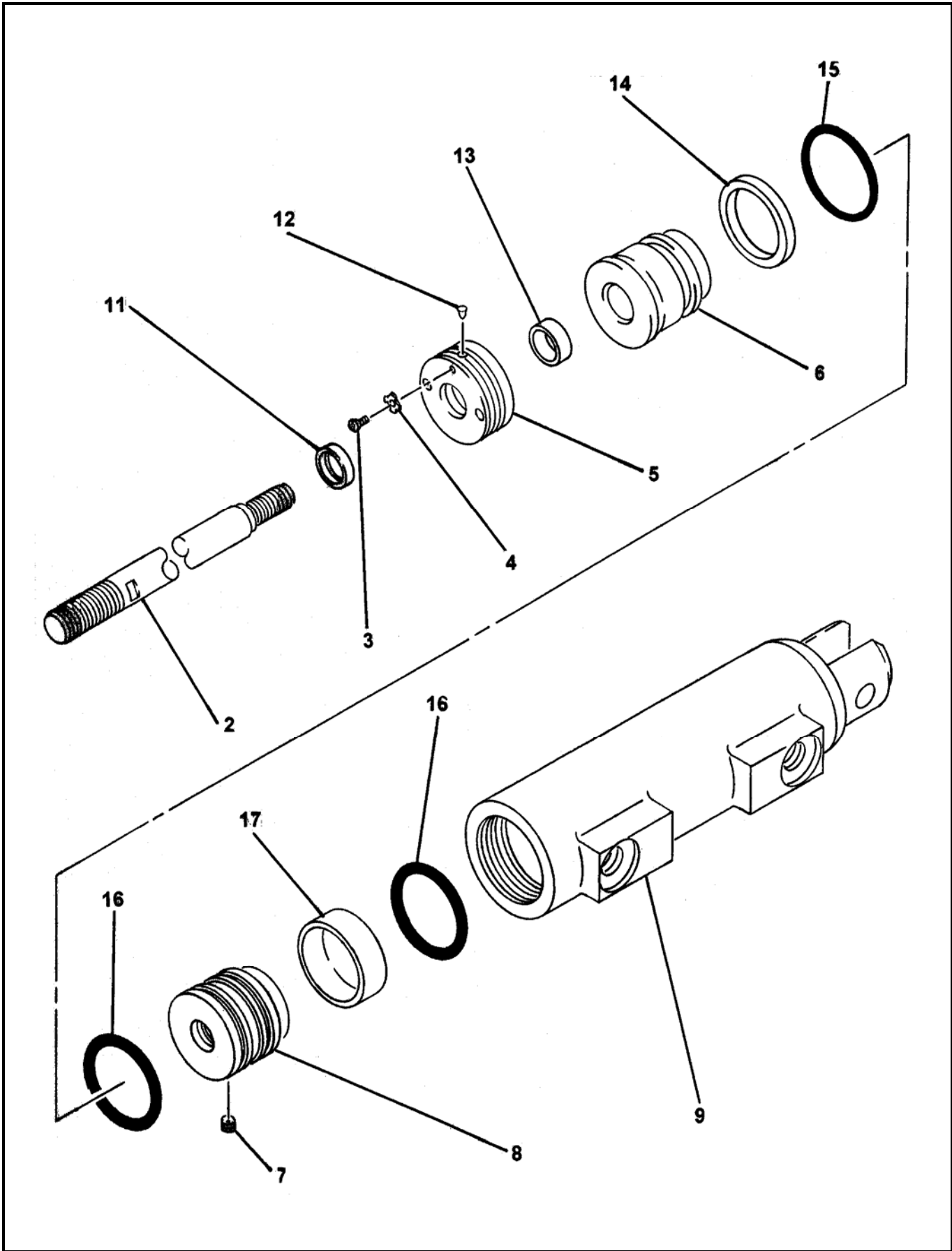

REVISION:



# SWING RAM CYLINDER ASSEMBLY

**A40**  
**PARTS**  
GROUP 60  
FIGURE 03  
PAGE 02

ITEM NO.	REED'S PARTS NO.	DESCRIPTION	QTY
		1 2 3 4 5	
-1	BW10374	Assembly, Swing Ram Cylinder (See Group 60, Figure 02 for NHA)	Ref
2		• Rod, Cylinder	1
3		• Screw, Cap	1
4		• Washer, Lock	1
5		• Ring, Threaded	1
6		• Gland, Head	1
7		• Screw, Set	1
8		• Piston	1
9		• Weldment, Cylinder Case	1
-10	BW10374-SK	• Kit, Seal	1
11		• • Wiper, Rod	1
12		• • Plug, Nylon	1
13		• • U-Cup	1
14		• • Seal, Back Up	1
15		• • O-Ring	1
16		• • Seal, Piston	2
17		• • Ring, Wear	1
		DASH (-) ITEM NOT ILLUSTRATED	

REVISION:



# CONCRETE CYLINDER ASSEMBLY

A40  
PARTS  
GROUP 60  
FIGURE 04  
PAGE 01

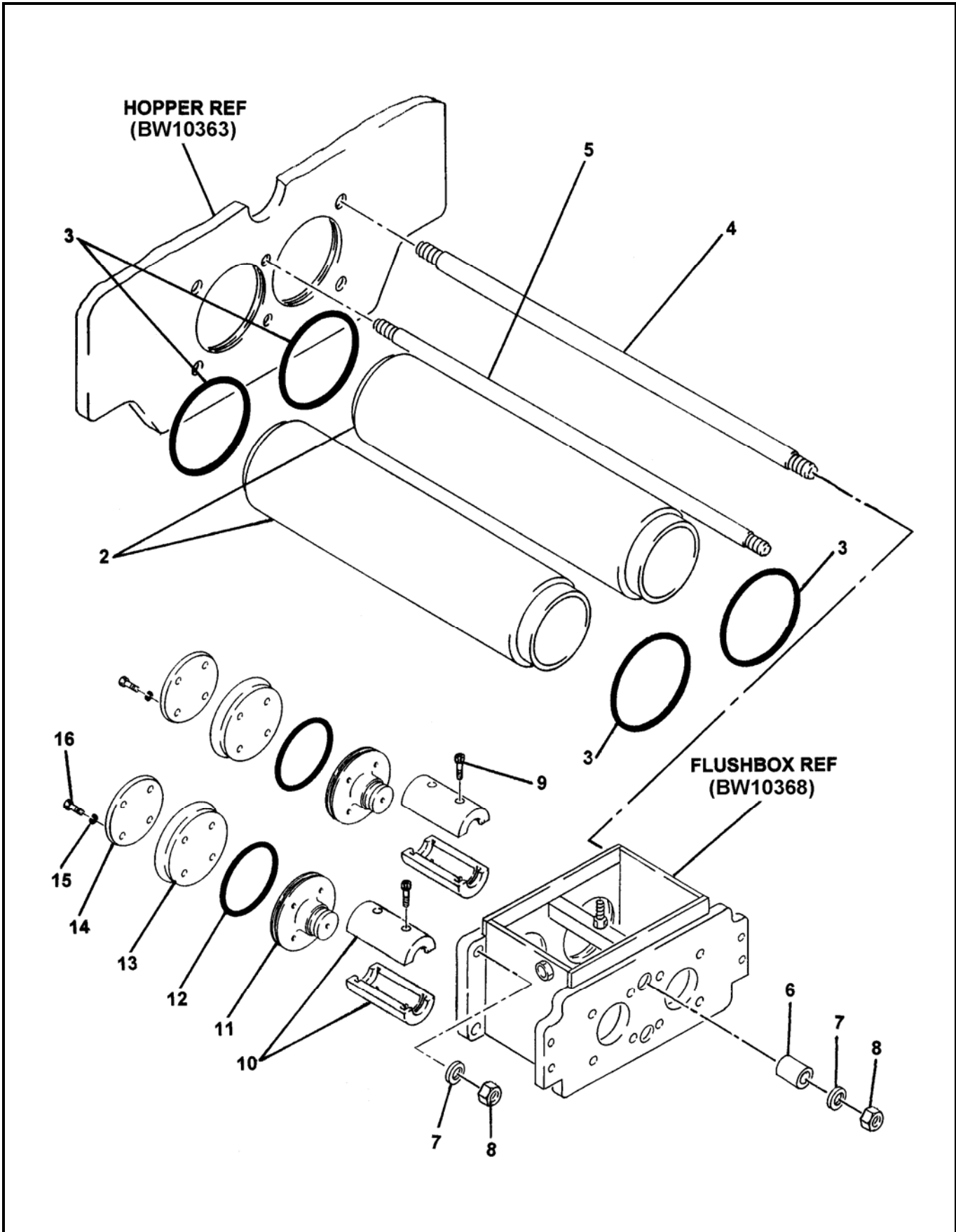

REVISION:





# CONCRETE CYLINDER ASSEMBLY

**A40**  
**PARTS**  
GROUP 60  
FIGURE 04  
PAGE 02

ITEM NO.	REED'S PARTS NO.	DESCRIPTION	QTY
		1 2 3 4 5	
-1	BW23040	Group, Concrete Cylinder (See Group 60, Figure 01 for NHA)	Ref
2	BW10376	• Cylinder, Concrete-6" X 30"	2
3	86149	• O-Ring, Concrete Cylinder	4
4	BW10380	• Rod, Tie-Short	4
5	BW10381	• Rod, Tie-Long	2
6	BW10379	• Spacer, Tie Rod	2
7		• Washer, Flat (attaching Parts)	6
8		• Nut, Hex (attaching Parts)	6
9		• Screw, Cap	4
10	73425	• Coupling, Piston	2
11	77194	• Adapter, 6 Inch Piston	2
12	77120	• Ring, Wear 6 Inch (Guide Band)	2
13	70048	• Cup, 6 Inch Piston	2
14	70057	• Plate, 6 Inch Piston	2
15		• Washer, Star (attaching Parts)	8
16		• Bolt, Hex (attaching Parts)	8
		DASH (-) ITEM NOT ILLUSTRATED	

REVISION:





# FLUSH BOX ASSEMBLY

A40  
PARTS  
GROUP 60  
FIGURE 05  
PAGE 01

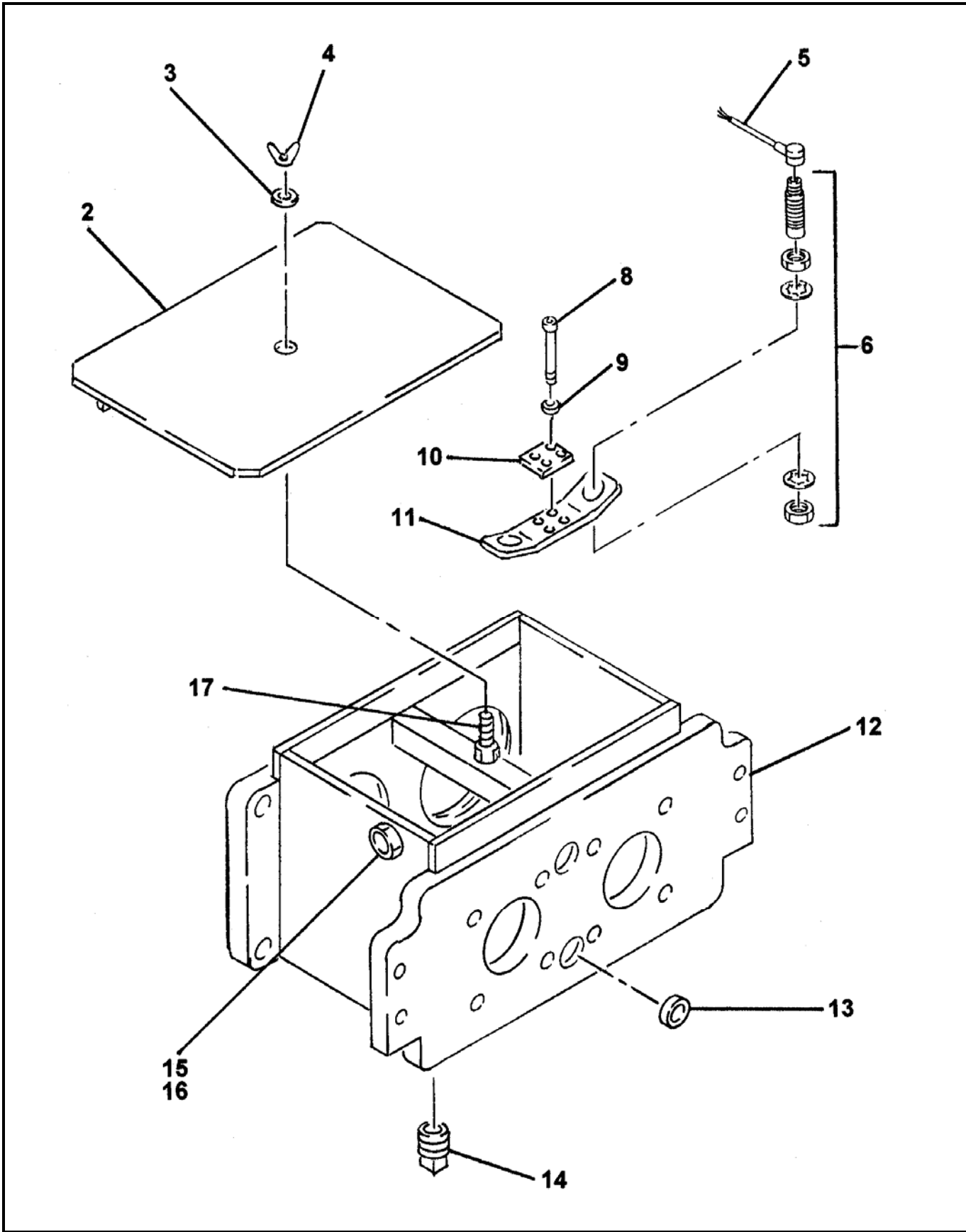

REVISION:



# FLUSH BOX ASSEMBLY

**A40**  
**PARTS**  
GROUP 60  
FIGURE 05  
PAGE 02

ITEM NO.	REED 'S PARTS NO.	DESCRIPTION	QTY
		1 2 3 4 5	
-1	60-05	Assembly, Flush Box-6 Inch (See Group 60, Figure 01 for NHA)	Ref
2	BW10387	• Weldment, Flush Box Cover	1
3		• Washer, Flat	1
4		• Nut, Wing	1
5	77990	• Cable, Proximity Switch	2
6	77998	• Sensor, Proximity Switch	2
-7	BW22040	• Assembly, Flush Box Group	1
8		• • Bolt	4
9		• • Washer, Lock	4
10	BW10102	• • Bracket, Proximity Switch	1
11	BW10383	• • Bracket, Proximity Switch	1
12	BW10368	• • Weldment, 6 Inch Flush Box	1
13	BW10030	• • Seal, Oil	4
14	10282	• • Plug	1
15	10528	• • Nut	1
16	73783	• • Conduit, Fitting	1
17	BW10193	• • Stud	1
DASH (-) ITEM NOT ILLUSTRATED			

REVISION:



# HYDRAULIC DRIVE CYLINDER ASSEMBLY

A40  
PARTS  
GROUP 60  
FIGURE 06  
PAGE 01

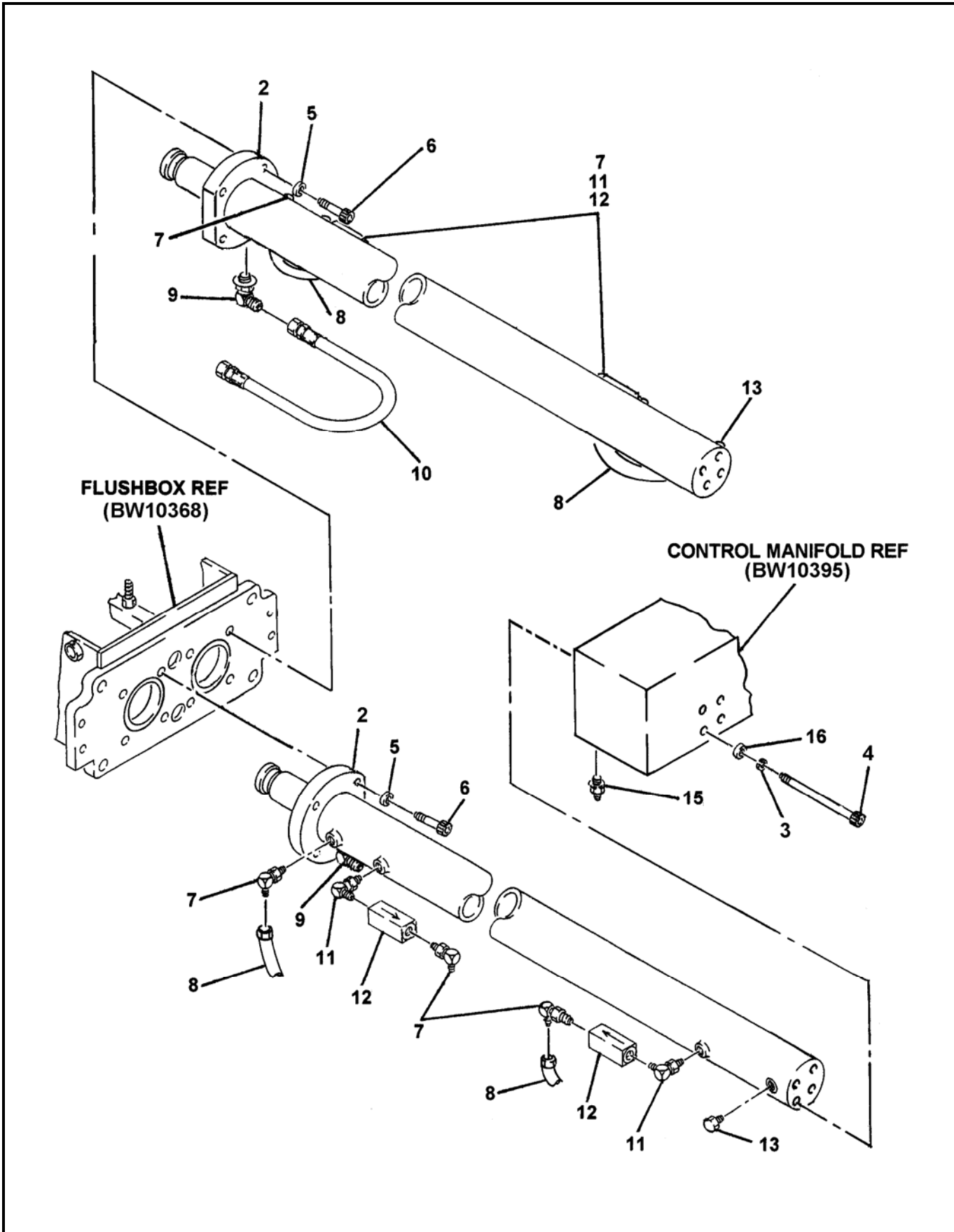

REVISION:



# HYDRAULIC DRIVE CYLINDER ASSEMBLY

**A40**  
**PARTS**  
GROUP 60  
FIGURE 06  
PAGE 02

ITEM NO.	REED'S PARTS NO.	DESCRIPTION	QTY
		1 2 3 4 5	
-1	BW21040	Group, Hydraulic Drive Cylinder (See Group 60, Figure 01 and Figure 02 for NHA)	Ref
2	BW10373	• Cylinder, Drive-3.75 X 30 (See Group 60, Figure 07 for DET)	2
3		• Washer, Lock	8
4		• Bolt	8
5		• Washer, Lock (attaching parts)	8
6		• Bolt (attaching parts)	8
7		• Fitting, 90	6
8	BW10051	• Assembly, Hose	4
9		• Fitting, 90	2
10	BW10394	• Assembly, Lube Line Hydraulic Tube	1
11	86728-023	• Fitting, 90	4
12	78961	• Valve, Check	4
13		• Plug	2
14	BW10177	• O-Ring	2
15		• Fitting, STR	2
16	BW10155	• Washer, Hardened	8
17			
18		DASH (-) ITEM NOT ILLUSTRATED	

REVISION:



# DRIVE CYLINDER ASSEMBLY

A40  
PARTS  
GROUP 60  
FIGURE 07  
PAGE 01

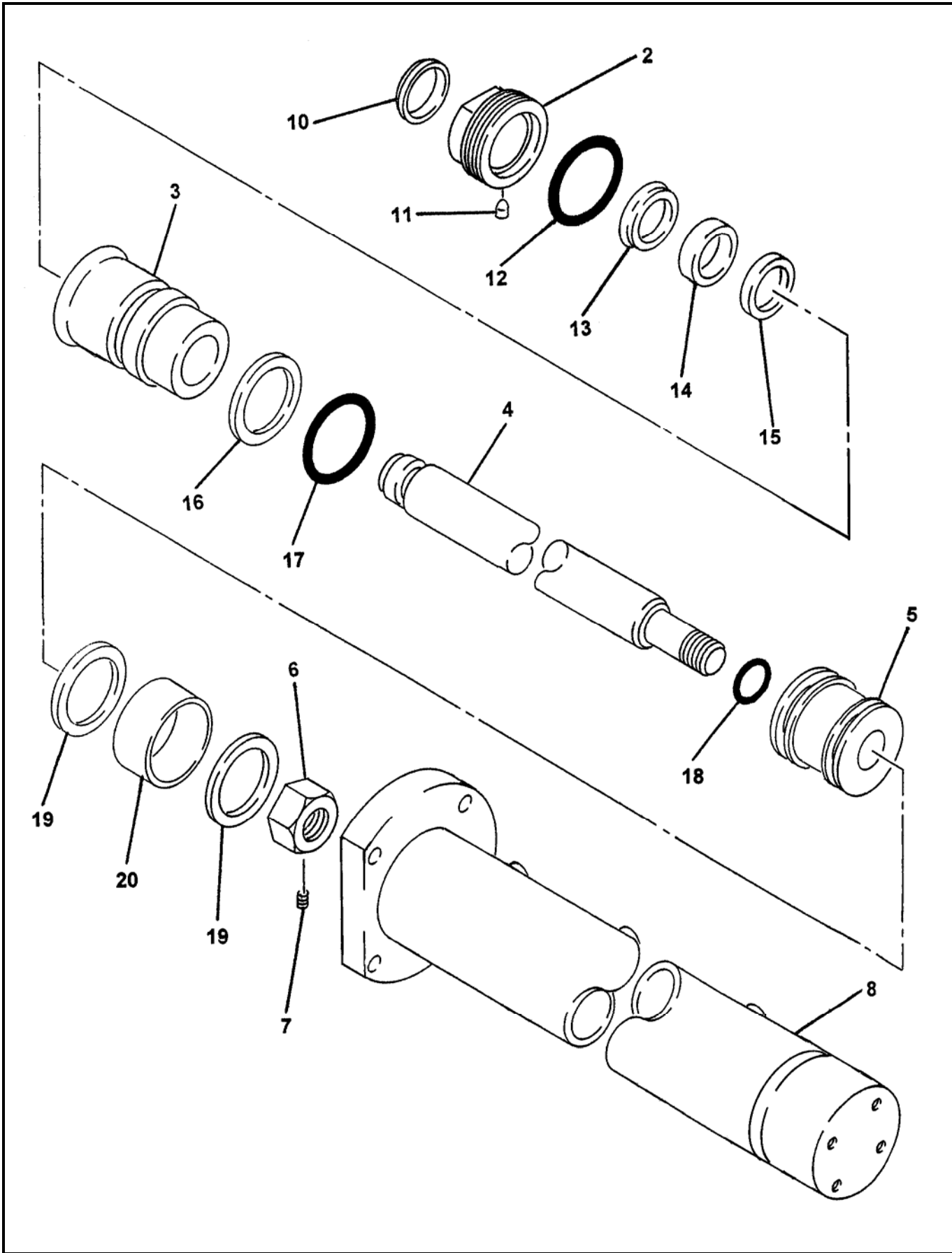

REVISION:



# DRIVE CYLINDER ASSEMBLY

**A40**  
**PARTS**  
GROUP 60  
FIGURE 07  
PAGE 02

ITEM NO.	REED'S PARTS NO.	DESCRIPTION					QTY
		1	2	3	4	5	
-1	BW10373	Assembly, Drive Cylinder (3.75 x 30) (See Group 60, Figure 06 for NHA)					Ref
2					• Ring, Threaded	1	
3					• Gland, Head	1	
4					• Rod, Cylinder	1	
5					• Piston	1	
6					• Nut, Piston	1	
7					• Plug	1	
8					• Weldment, Cylinder Case	1	
-9	BW10373-SK				• Kit, Seal	1	
10					•• Wiper, Rod	1	
11					•• Plug, Nylon	1	
12					•• O-Ring	1	
13					•• Ring, Back Up	1	
14					•• U-Cup	1	
15					•• Seal, Buffer	1	
16					•• Ring, Back Up	1	
17					•• O-Ring	1	
18					•• O-Ring	1	
19					•• Seal, Piston	2	
20					•• Ring, Wear	1	
DASH (-) ITEM NOT ILLUSTRATED							

REVISION:



# CONTROL MANIFOLD WITH CARTRIDGE ASSEMBLY

A40  
PARTS  
GROUP 60  
FIGURE 08  
PAGE 01

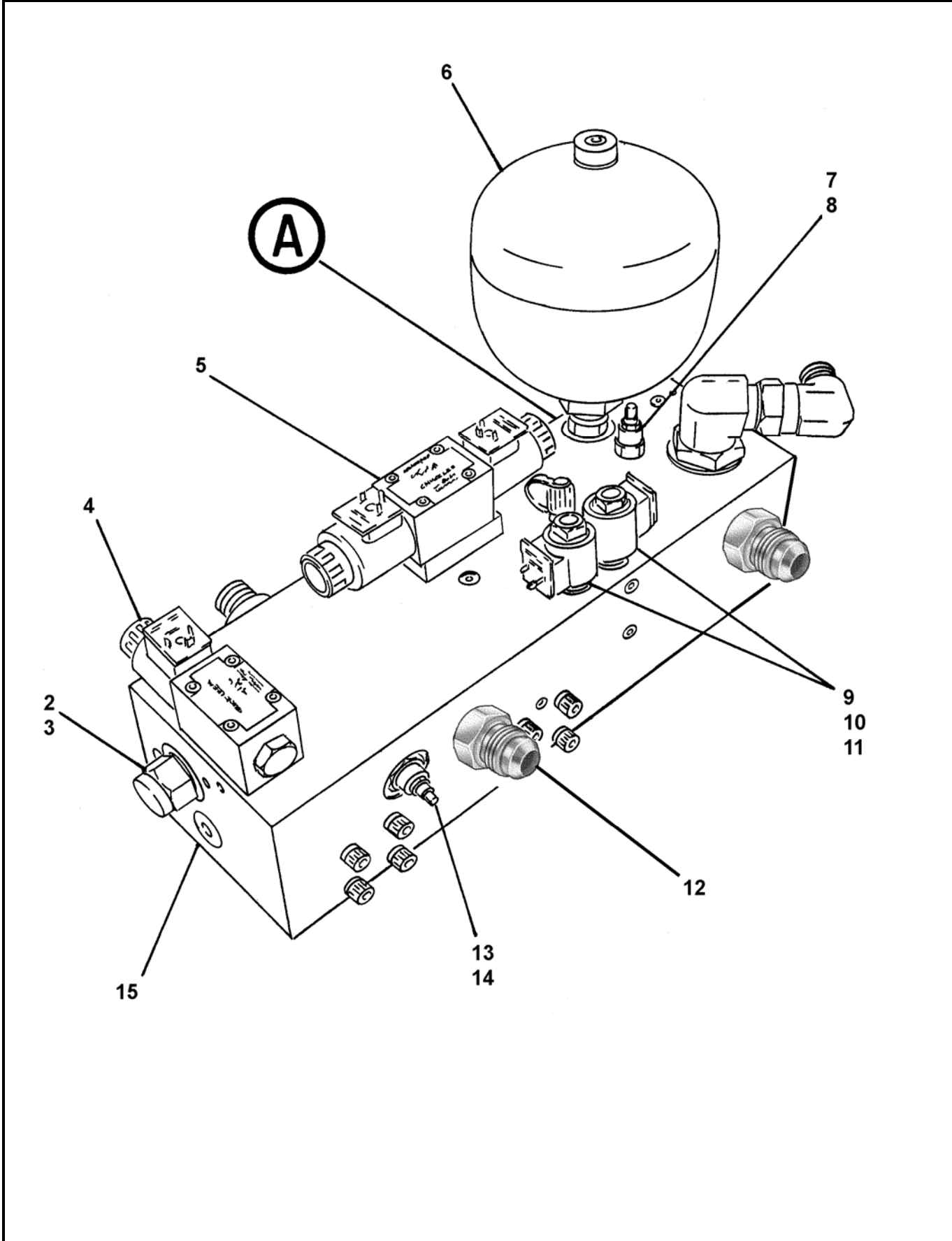

REVISION:





# RIGHT HAND SIDE DRIVE CYLINDER ASSEMBLY

**A40**  
**PARTS**  
GROUP 60  
FIGURE 08  
PAGE 02

ITEM NO.	REED'S PARTS NO.	DESCRIPTION					QTY
		1	2	3	4	5	
-1	BW10395	Assembly, Control Manifold with Cartridge (See Group 60, Figure 01 for NHA)					Ref
2	BW10181	• Cartridge, Directional Valve					1
3	BW10181-SK	• • Kit, Directional Valve Cartridge Seal					1
4	BW10183	• Assembly, Reverse Circuit Pilot Solenoid Valve (See Group 60, Figure 10 for DET)					1
5	85691	• Assembly, Main Cycling Circuit Pilot Solenoid Valve (See Group 60, Figure 11 for DET)					1
6	BW10184	• Assembly, 2 Liter Accumulator					1
7	85704	• Cartridge, Unloading Valve					1
8	85704-SK	• • Kit, Unloading Valve Cartridge Seal					1
9	BW10185	• Poppet, 2 Way Solenoid Valve Less Coil					2
10	BW10186	• Coil, 2 Way Solenoid Valve					2
11		• Kit, 2 Way Solenoid Valve Seal					2
12	86900-028	• Adapter, MB-MJ-16-16					4
13	BW10326	• Cartridge, Relief Valve					1
14		• • Kit, Relief Valve Cartridge Seal					1
15	BW10375	• Body, Manifold					1
16	85703	• Cartridge, Relief Valve					1
17	85703-SK	• • Kit, Relief Valve Cartridge Seal					1
18	BW10182	• Cartridge, Directional Valve					1
19	BW10182-SK	• • Kit, Directional Valve Cartridge Seal					1
20	BW10327	• Valve, Check					1
21	78593	• Adapter, Minicheck					3
-22	86900-024	• Adapter, MB-MJ-12-16					1
-23	BW10328	• Adapter, MB-MB-12-12					1
-24	86900-023	• Adapter, MB-MJ-12-12					2
-25	86728-028	• Elbow, MB-MJ90-20-24					1
-26	86905-012	• Elbow, MJ-FJX90-24-24					1
-27	BW10177	• O-Ring-#219					2
-28	BW10329	• SHCS 10-24 x 2" Long					8
-29	86900-002	• Adapter, MB-MJ-4-6					2
DASH (-) ITEM NOT ILLUSTRATED							

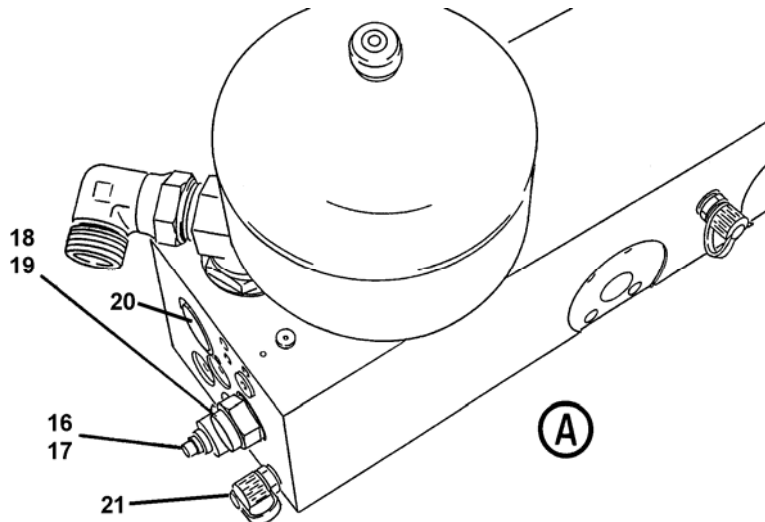

REVISION:



# REVERSE CIRCUIT PILOT SOLENOID VALVE ASSEMBLY

A40  
PARTS  
GROUP 60  
FIGURE 09  
PAGE 01

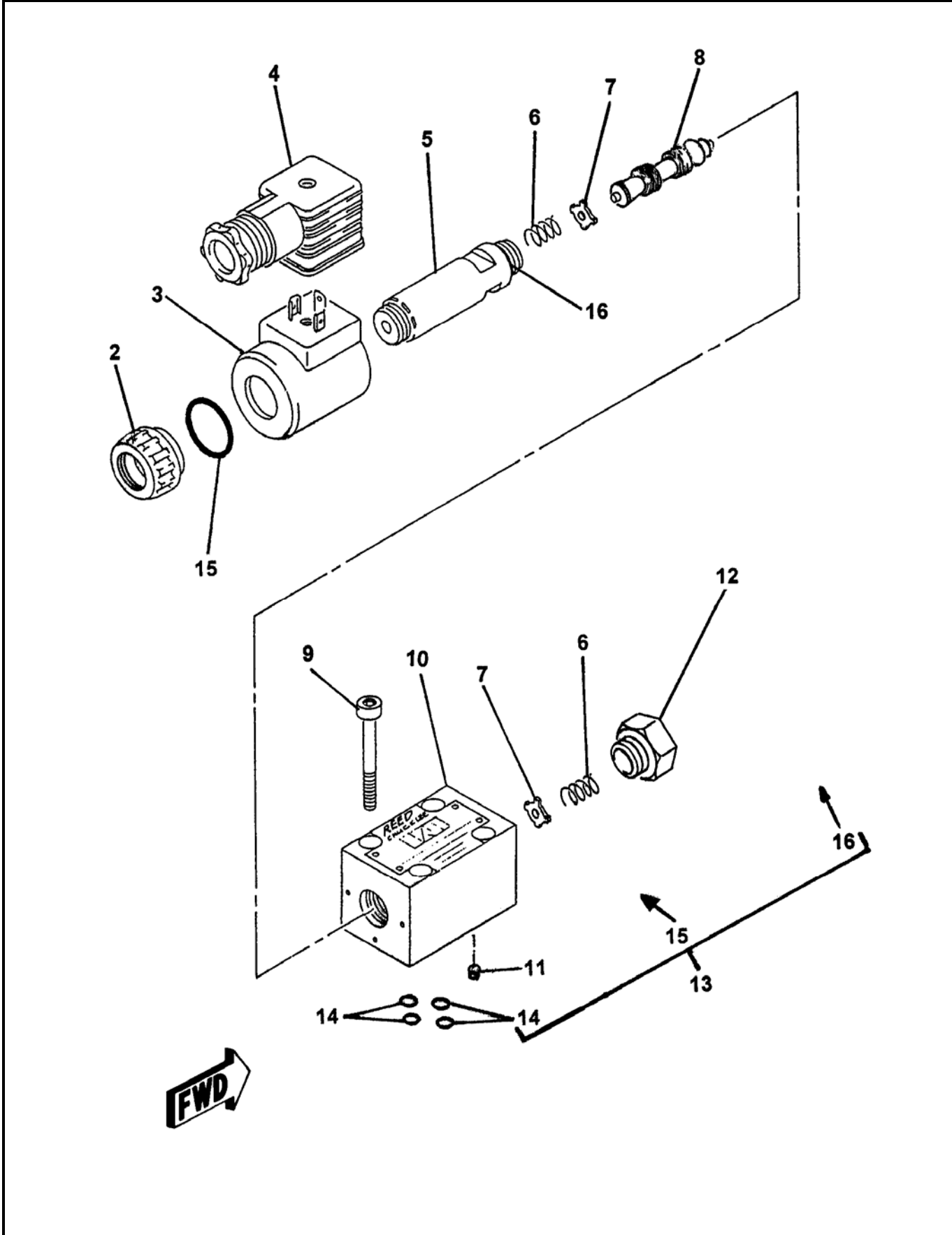

REVISION:



# CONTROL MANIFOLD WITH CARTRIDGE ASSEMBLY

**A40**  
**PARTS**  
GROUP 60  
FIGURE 09  
PAGE 02

ITEM NO.	REED'S PARTS NO.	DESCRIPTION					QTY
		1	2	3	4	5	
-1	BW10183	Assembly, Reverse Circuit Pilot Solenoid Valve (See Group 60, Figure 09 for NHA)					Ref
2		• Cap, Coil					1
3	85692	• Coil, Drive Cylinder Circuit Main Solenoid					1
4	74597	• Connector, Plug					1
5		• Amature					1
6		• Spring					2
7		• Plate, Spring					2
8		• Spool					1
9		• Screw, SOC					4
10		• Housing, Solenoid Valve					1
11		• Orfice					1
12		• Plug					1
13	72313	• Kit, O-Ring					1
14		•• O-Ring					4
15		•• O-Ring					1
16		••• O-Ring					1

DASH (-) ITEM NOT ILLUSTRATED

REVISION:

## MAIN CYCLING CIRCUIT PILOT SOLENOID VALVE ASSEMBLY

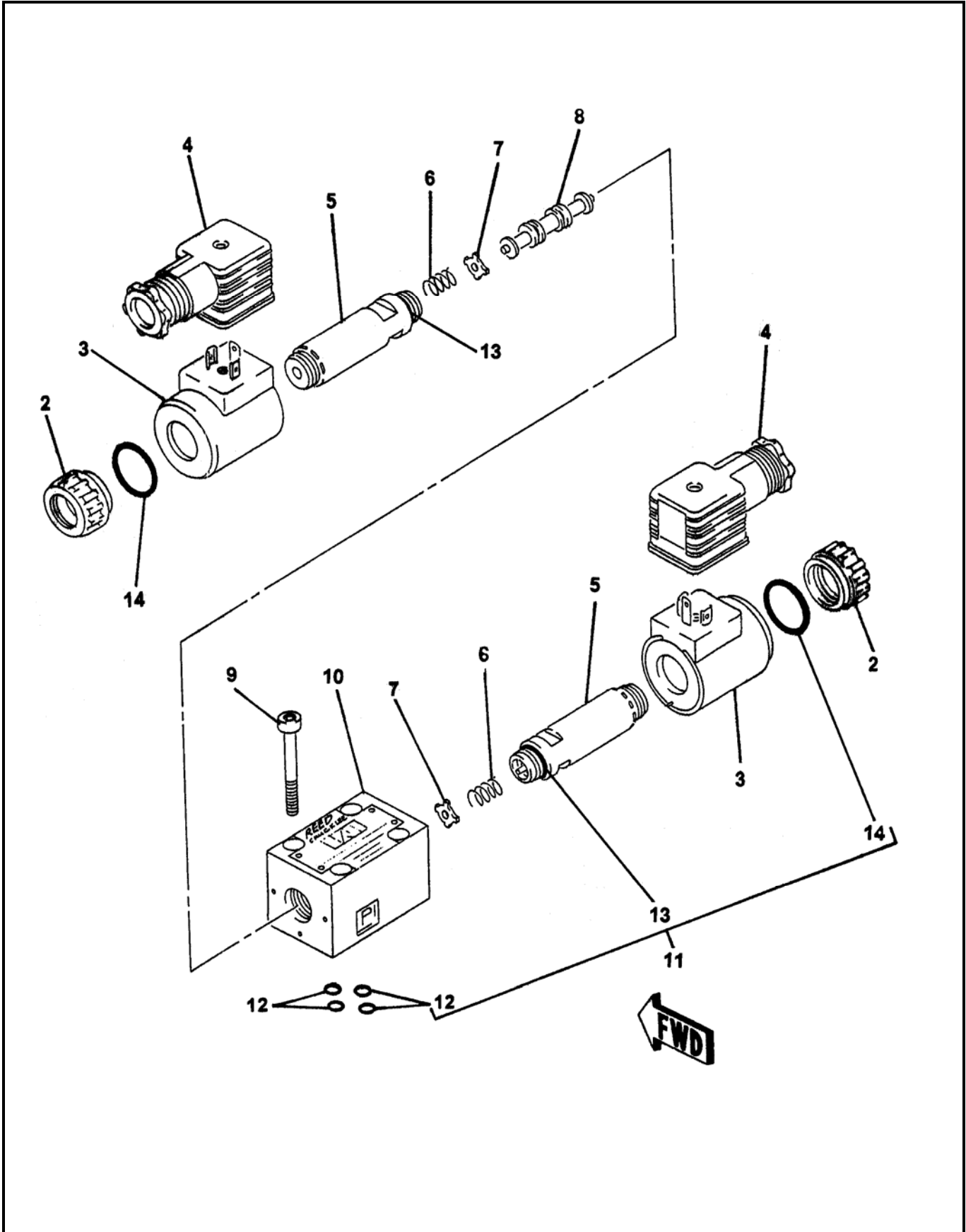

REVISION:



# MAIN CYCLING CIRCUIT PILOT SOLENOID VALVE ASSEMBLY

**A40**  
**PARTS**  
GROUP 60  
FIGURE 10  
PAGE 02

ITEM NO.	REED'S PARTS NO.	DESCRIPTION					QTY
		1	2	3	4	5	
-1	85691	Assembly, Main Cycling Circuit Pilot Solenoid Valve (See Group 60, Figure 09 for NHA)					Ref
2		• Cap, Coil					2
3	85692	• Coil, Solenoid					2
4	74597	• Connector, Plug					2
5		• Amature					2
6		• Spool					1
7		• Screw, SOC					4
8		• Housing, Solenoid Valve					1
9		• Detent					1
10		• Orifice					1
11	72313	• Kit, O-ring					1
12		•• O-Ring					4
13		•• O-ring					2
14		•• O-ring					2

DASH (-) ITEM NOT ILLUSTRATED

REVISION:



**TRAILER MOUNTED PUMP – A40  
ILLUSTRATED PARTS MANUAL**

**A40**  
**PARTS**  
GROUP 60  
FIGURE 11  
PAGE 01

THIS PAGE INTENTIONALLY LEFT BLANK.



**REED** TRAILER MOUNTED CONCRETE PUMP MODEL **A40** ILLUSTRATED PARTS MANUAL GROUP 70 FRAME INSTALLATION CONTAINS THE FOLLOWING FIGURES:

- FIGURE 00** TABLE OF CONTENTS
- FIGURE 01** FRAME INSTALLATION
- FIGURE 02** HUB AND BRAKE ASSEMBLY
- FIGURE 03** NON-OPERATOR SIDE ELECTRIC BRAKE ASSEMBLY
- FIGURE 04** OPERATOR SIDE ELECTRIC BRAKE ASSEMBLY

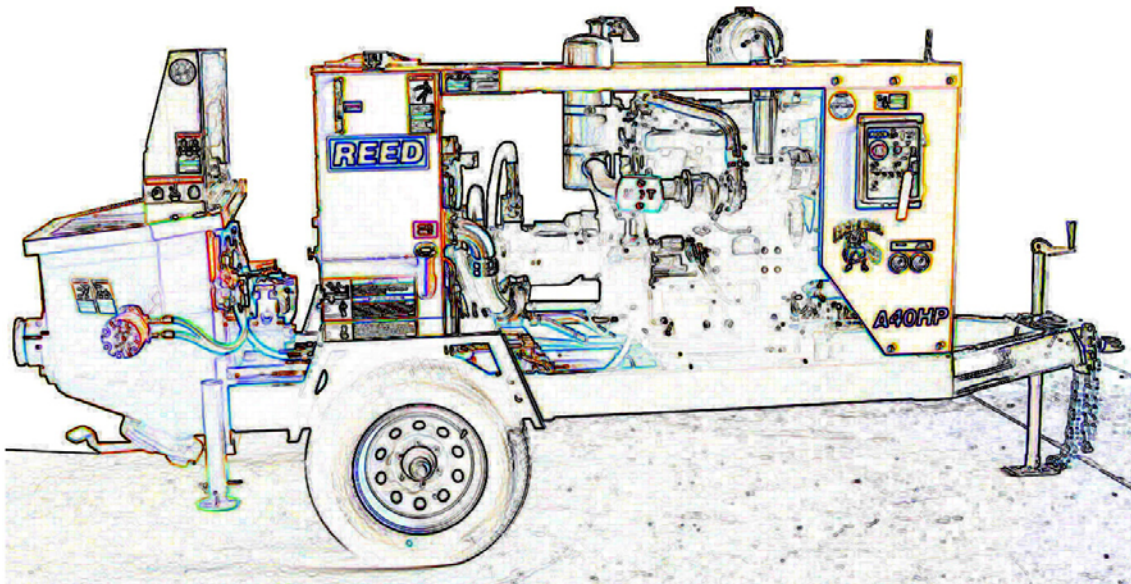



# FRAME INSTALLATION

A40  
PARTS  
GROUP 70  
FIGURE 01  
PAGE 01

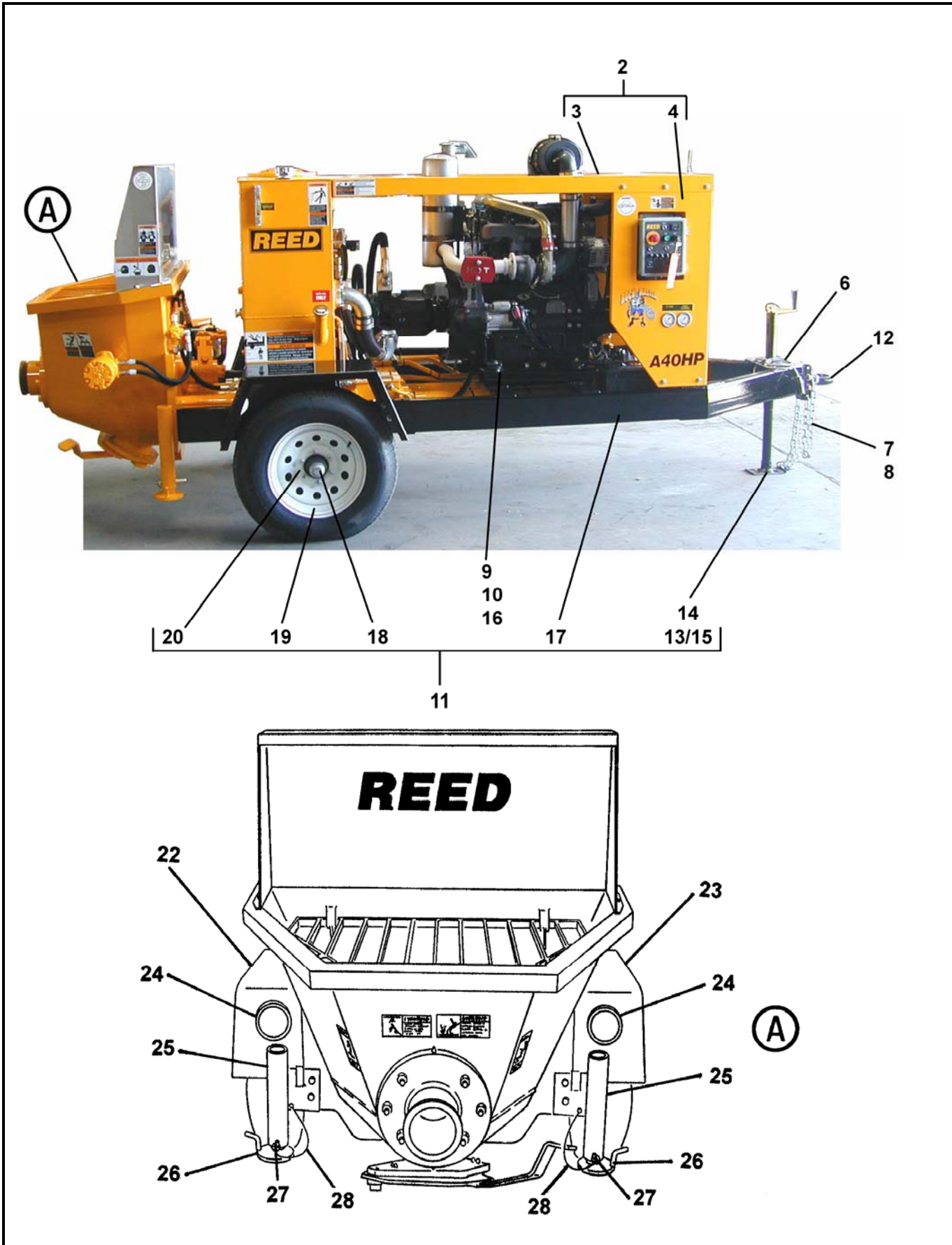

REVISION:



# FRAME INSTALLATION

**A40**  
**PARTS**  
 GROUP 70  
 FIGURE 01  
 PAGE 02

ITEM NO.	REED'S PARTS NO.	DESCRIPTION	QTY
		1 2 3 4 5	
-1	70-01	Installation, Frame (See Group 10, Figure 01 for NHA)	Ref
2	BW45020	• Group, Cover	1
3	BW10399	•• Cover, Engine Top	1
4	BW10400	•• Cover, Engine Front	1
-5	BW41020	• Group, Frame	1
6	77705	•• Kit, Break Away	1
7	86243	•• Connector, Chain	2
8	86242	•• Chain, 3/8 Proof Coil GR 30 Zinc 6 FT	1
9	BW10266	•• Engine Mount-Front (Yellow)	2
10	BW10270	•• Engine Mount-Rear (Green)	2
11	BW10252	•• Assembly, Frame	1
12	71051	••• Lunette, 3 Inch Eye	1
13	BW10099	••• Jack, Caster	1
14	BW10098	••• Jack	1
15	BW10169	••• Jack, Foot	1
16	BW10267	••• Fender Washer-3/4" ID	4
17	BW10398	••• Weldment, Frame	1
18	BW10095	••• Axle	1
19	BW10096	••• Assembly, Tire and Wheel	2
20	70-02	••• Assembly, Hub and Brake (See Group 70, Figure 02 for DET)	1
-21	BW10180	••• Spacer, Axle Mount	2
22	BW10349	•• Weldment, Left Fender	1
23	BW10350	•• Weldment, Right Fender	1
24	72948	•• Light, Tail	2
25	BW10114	•• Weldment, Outrigger Outer Tube	2
26	BW10110	•• Weldment, Outrigger Inner Leg	2
27	85595	•• Pin, Outrigger Safety	2
28	800418	•• Lanyard, Q/R Pin	2
-29	85981	•• Clamp, Loom	3
-30	86759	•• Grommet, Trailer	5
-31	801902-007	•• Clamp, Tube-Single	6
-32	801902-001	•• Nut, Tee-Tube Clamp	10
DASH (-) ITEM NOT ILLUSTRATED			

REVISION:

## HUB AND BRAKE ASSEMBLY

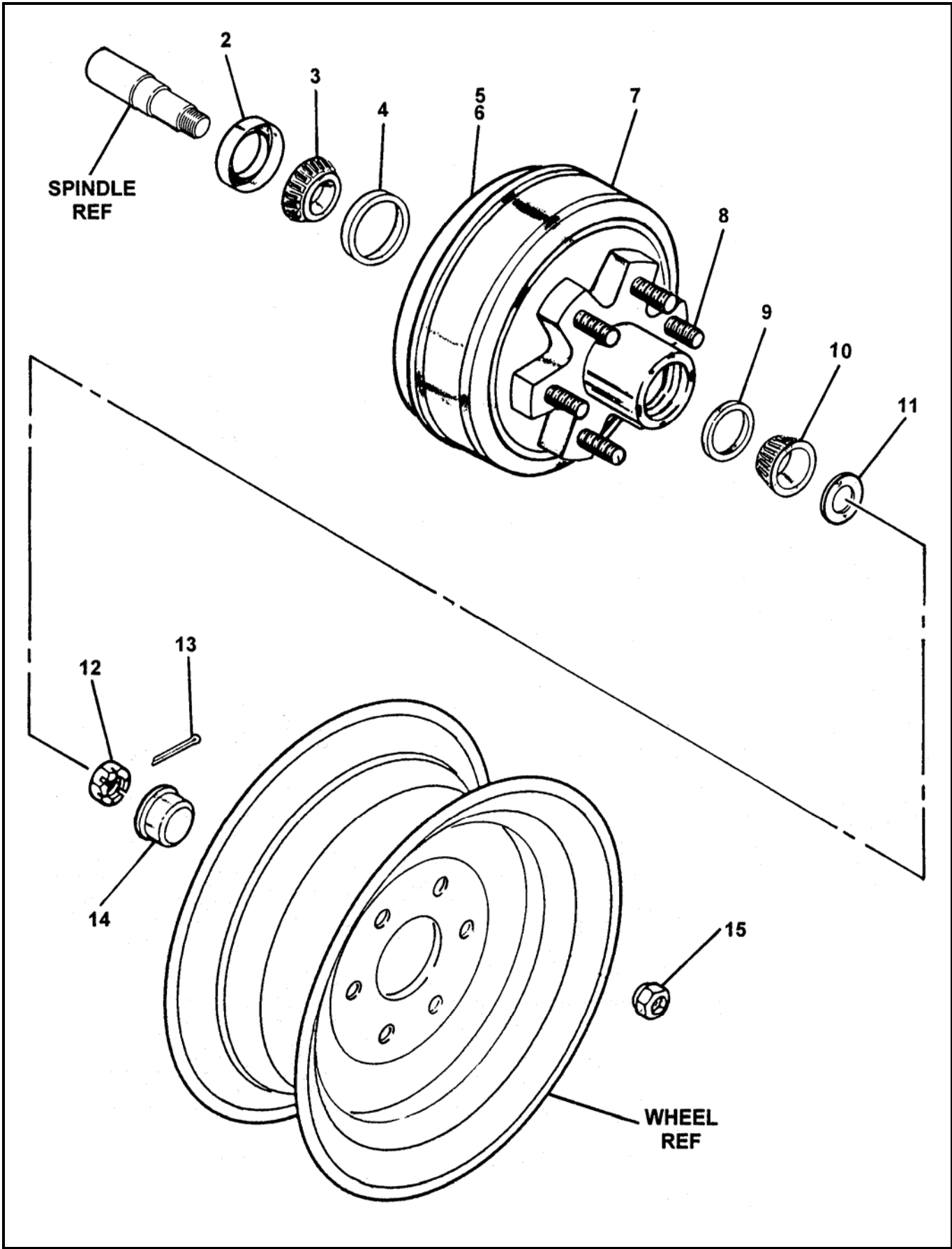



# HUB AND BRAKE ASSEMBLY

**A40**  
**PARTS**  
GROUP 70  
FIGURE 02  
PAGE 02

ITEM NO.	REED'S PARTS NO.	DESCRIPTION	QTY
		1 2 3 4 5	
-1	70-02	Assembly, Hub and Brake (Left And Right Side) (See Group 70, Figure 01 for NHA)	Ref
2	86709	• Seal, Double Lip Grease	2
3	71094	• Bearing, Inner	2
4	71092	• Race, Inner Bearing	2
5	71056-L	• Assembly, Non-Operator Side Electric Brake (Set) (See Group 70, Figure 03 for DET)	1
6	71056-R	• Assembly, Operator Side Electric Brake (Set) (See Group 70, Figure 04 for DET)	1
7		• Assembly, Drum And Hub	2
8		• Stud, Wheel	12
9		• Race, Outer Bearing	2
10		• Bearing, Outer	2
11		• Washer, Spindle	2
12		• Nut, Spindle	2
13		• Pin, Cotter	2
14		• Cap, Dust	2
15		• Nut, Wheel	12

DASH (-) ITEM NOT ILLUSTRATED

REVISION:



# NON OPERATOR SIDE ELECTRIC BRAKE ASSEMBLY

**A40**  
**PARTS**  
GROUP 70  
FIGURE 03  
PAGE 01

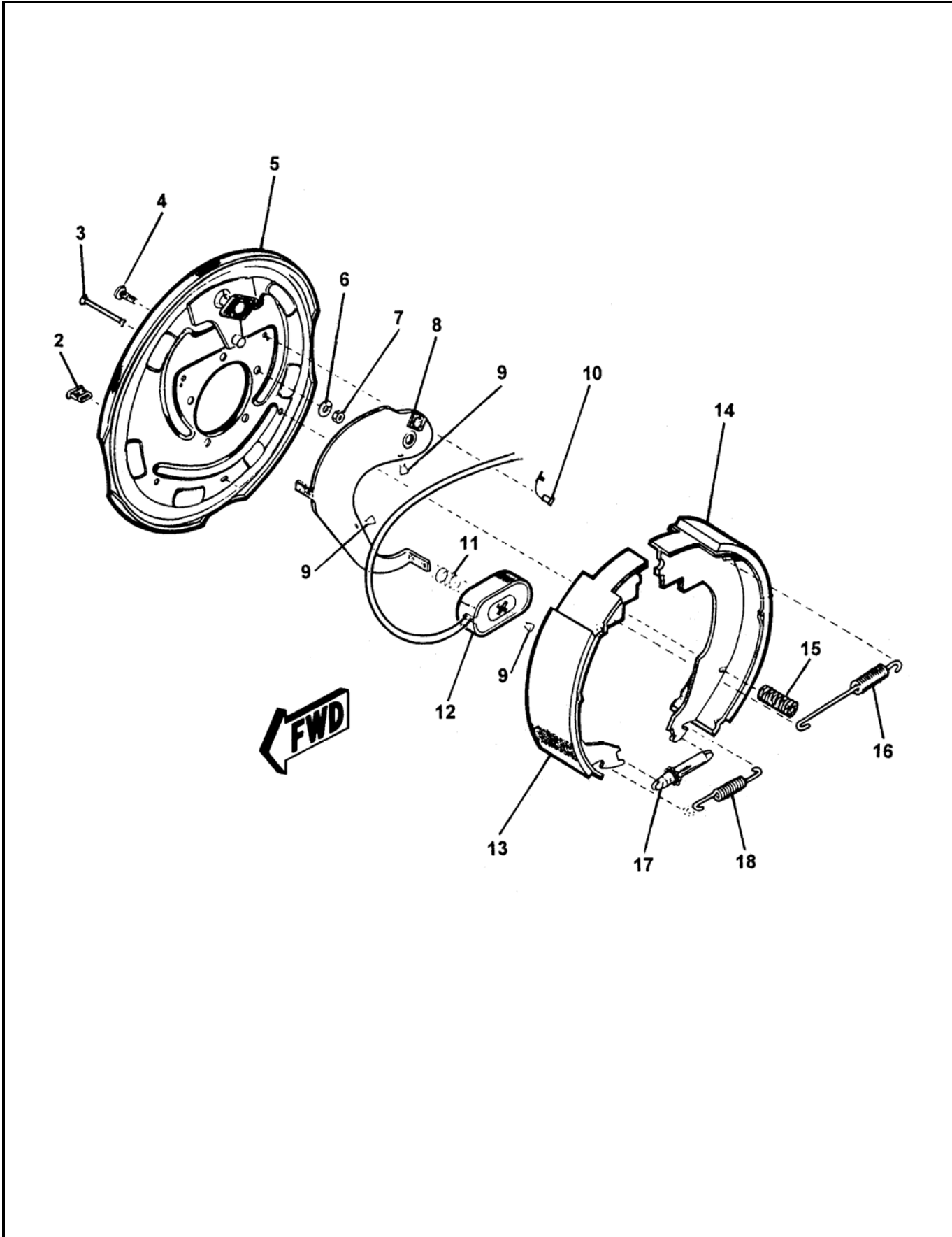

REVISION:





# NON OPERATOR SIDE ELECTRIC BRAKE ASSEMBLY

**A40**  
**PARTS**  
GROUP 70  
FIGURE 03  
PAGE 02

ITEM NO.	REED'S PARTS NO.	DESCRIPTION	QTY
		1 2 3 4 5	
-1	71056-L	Assembly, Non-Operator Side Electric Brake (See Group 70, Figure 02 for NHA)	Ref
2		• Slot, Plug Adjust	1
3		• Pin, Shoe Hold down	1
4		• Stud, Brake Mounting	5
5		• Assembly, Baking Plate	1
6		• Washer, Brake Lock	5
7		• Nut, Brake Mounting	5
8		• Lever, Non-Operator Side	1
9		• Clip, Wire and Magnet	3
10		• Relief, Strain	2
11		• Spring, Magnet	1
12		• Sub-Assembly, Magnet	1
13		• Shoe and Lining, Primary	1
14		• Shoe and Lining, Secondary	1
15		• Spring, Shoe Hold down	1
16		• Spring, Shoe Retractor	1
17		• Sub-Assembly, Adjuster Screw	1
18		• Spring, Adjuster Screw	1

DASH (-) ITEM NOT ILLUSTRATED

REVISION:





# OPERATOR SIDE ELECTRIC BRAKE ASSEMBLY

A40  
PARTS  
GROUP 70  
FIGURE 04  
PAGE 01

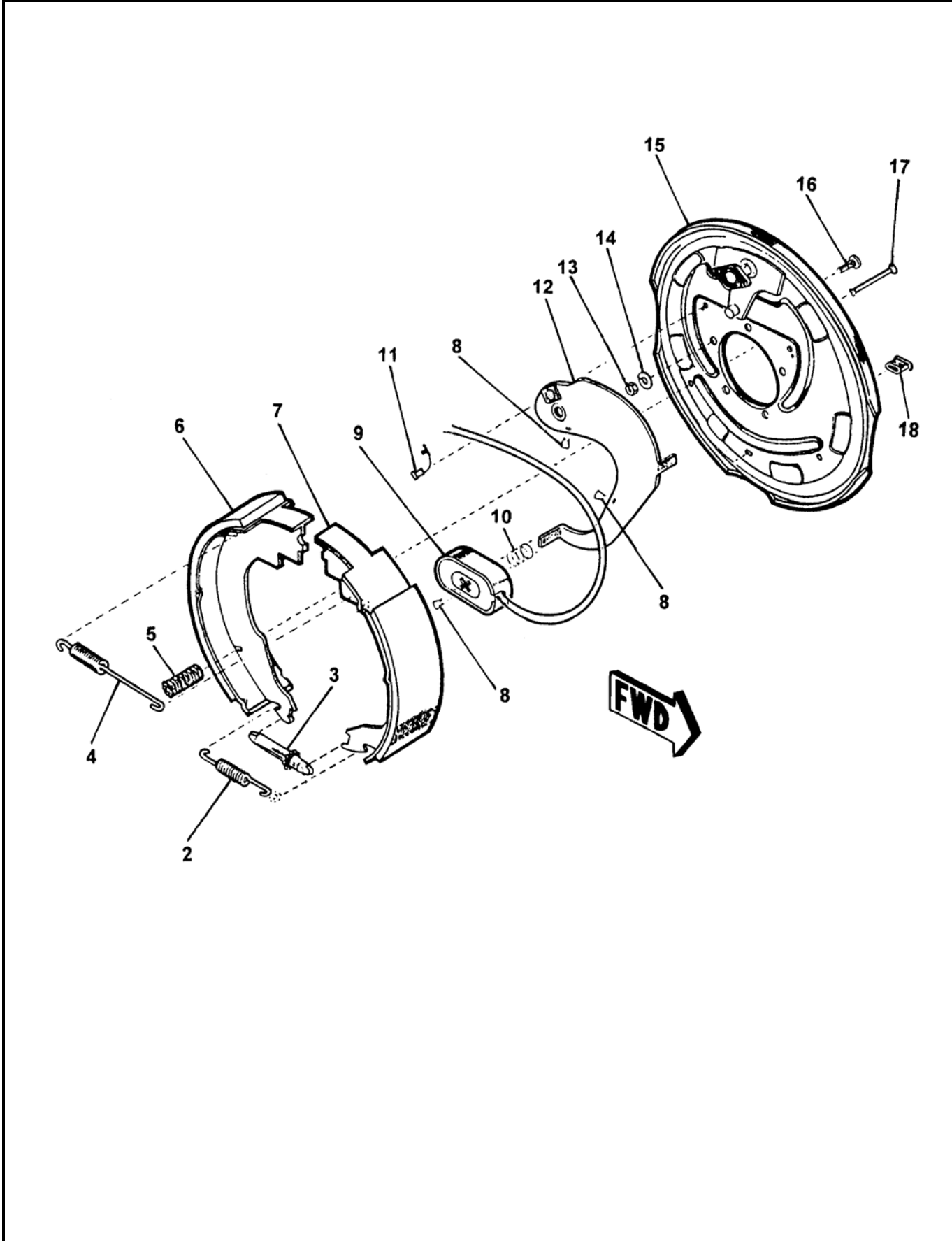

REVISION:



**OPERATOR SIDE  
ELECTRIC BRAKE ASSEMBLY**

**A40**  
**PARTS**  
GROUP 70  
FIGURE 04  
PAGE 02

ITEM NO.	REED'S PARTS NO.	DESCRIPTION	QTY
		1 2 3 4 5	
-1	71056-R	Assembly, Operator Side Electric Brake (See Group 70, Figure 02 for NHA)	Ref
2		• Spring, Adjuster Screw	1
3		• Sub-Assembly, Adjuster Screw	1
4		• Spring, Shoe Retractor	1
5		• Spring, Shoe Hold down	1
6		• Shoe and Lining, Secondary	1
7		• Shoe and Lining, Primary	1
8		• Clip, Wire and Magnet	3
9		• Sub-Assembly, Magnet	1
10		• Spring, Magnet	1
11		• Relief, Strain	2
12		• Lever, Operator Side	1
13		• Nut, Brake Mounting	5
14		• Washer, Brake Lock	5
15		• Assembly, Baking Plate	1
16		• Stud, Brake Mounting	5
17		• Pin, Shoe Hold down	1
18		• Slot, Plug Adjust	1

DASH (-) ITEM NOT ILLUSTRATED

REVISION:

THIS PAGE INTENTIONALLY LEFT BLANK.

**REED** TRAILER MOUNTED CONCRETE PUMP MODEL **A40** ILLUSTRATED PARTS MANUAL GROUP 80 OPTIONAL INSTALLATION CONTAINS THE FOLLOWING FIGURES:

- FIGURE 00** TABLE OF CONTENTS
- FIGURE 01** OPTIONAL INSTALLATION
- FIGURE 02** HOPPER VIBRATOR ASSEMBLY
- FIGURE 03** OPTIONAL TOOL KIT ASSEMBLY
- FIGURE 04** ACTUATOR-SURGE BRAKES ASSEMBLY
- FIGURE 05** NON-OPERATOR SIDE HYDRAULIC BRAKE ASSEMBLY
- FIGURE 06** OPERATOR SIDE HYDRAULIC BRAKE ASSEMBLY

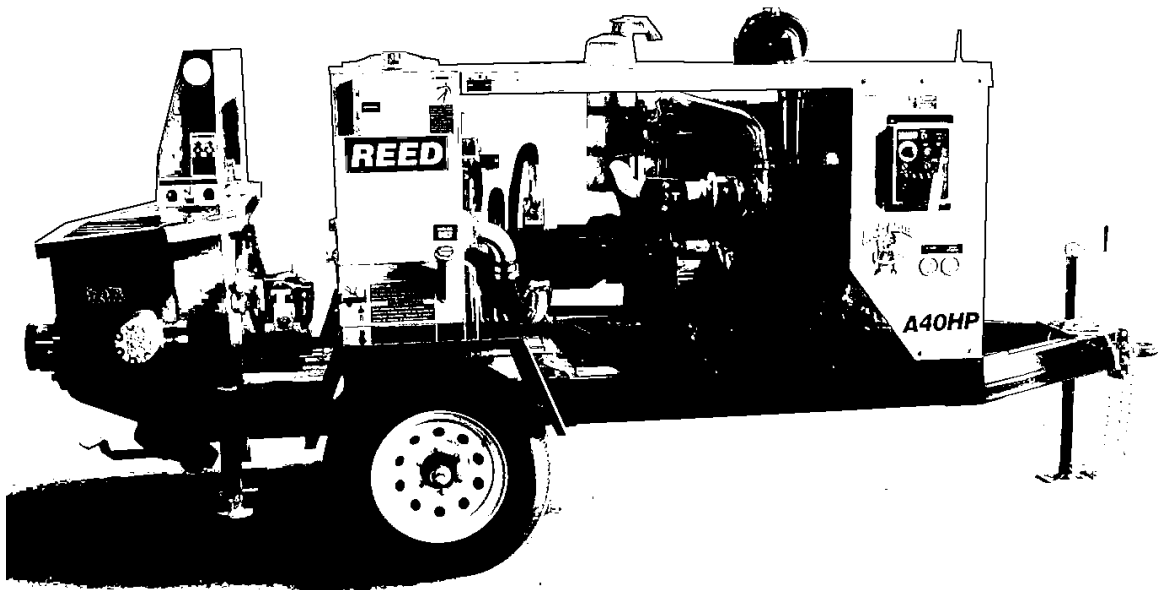



# OPTIONAL INSTALLATION

A40  
PARTS  
GROUP 80  
FIGURE 01  
PAGE 01

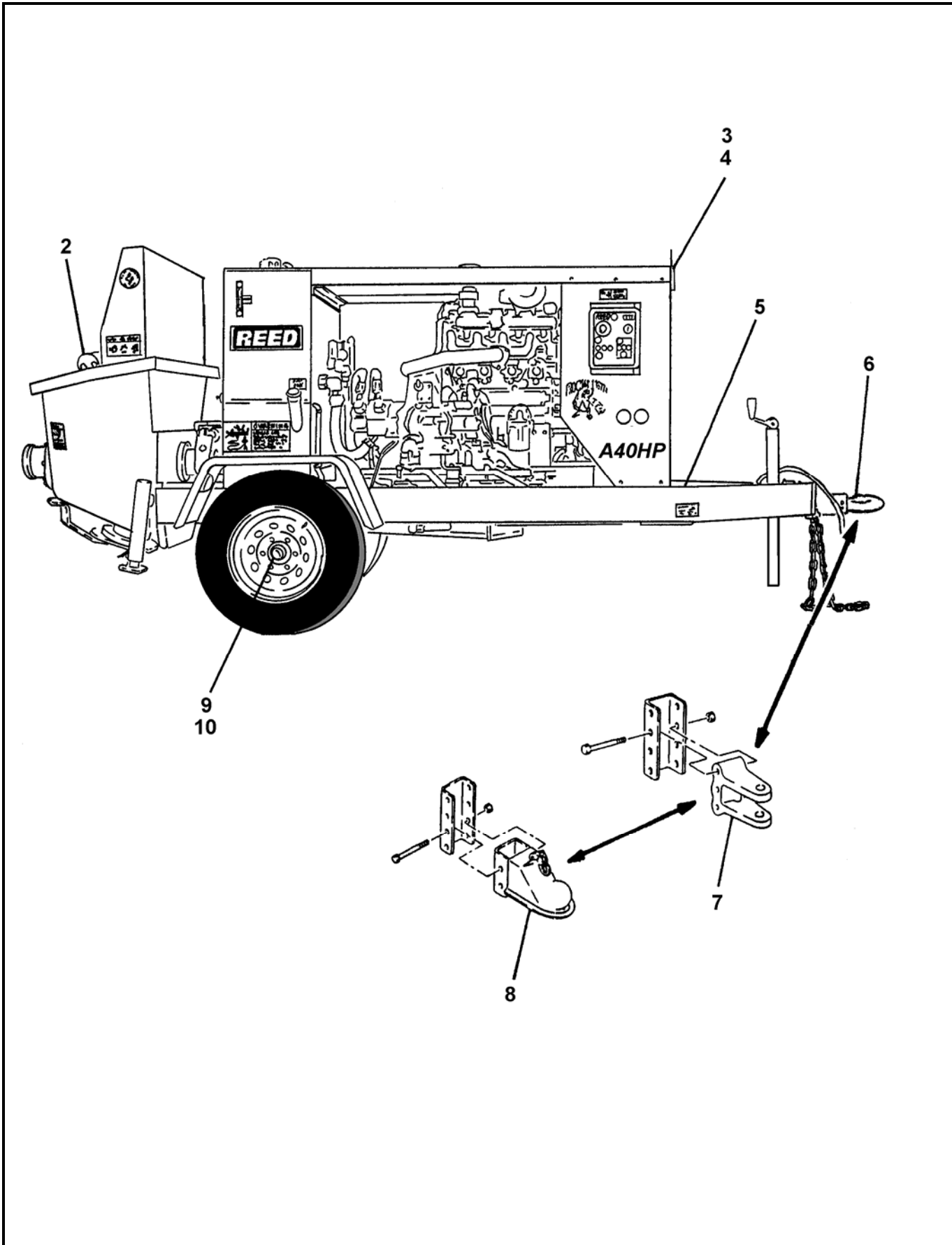

REVISION:



# OPTIONAL INSTALLATION

**A40**  
**PARTS**  
GROUP 80  
FIGURE 01  
PAGE 02

ITEM NO.	REED'S PARTS NO.	DESCRIPTION	QTY
		1 2 3 4 5	
-1	80-01	Installation, Optional (See Group 10, Figure 01 for NHA)	Ref
2	71429	• Assembly, Hopper Vibration (See Group 80, Figure 02 for DET)	1
3	BW10011	• Assembly, Radio Remote Control Transmitter (See Group 50, Figure 04 for REF)	1
4	BW10012	• Assembly, Radio Remote Control Receiver (See Group 50, Figure 04 for REF)	1
5	79020	• Assembly, Optional Tool Kit (See Group 80, Figure 03 for DET)	1
6	75413	• Assembly, Actuator Brake (See Group 80, Figure 04 for DET)	1
7	71050	• Assembly, Adjustable 1 Inch Clevis	1
8	71099	• Assembly, Adjustable Ball Coupler 2 – 5/16"	1
9	80-05	• Assembly, Non-Operator Side Hydraulic Brake (See Group 80, Figure 05 for DET)	1
10	80-06	• Assembly, Operator Side Hydraulic Brake (See Group 80, Figure 06 for DET)	1

DASH (-) ITEM NOT ILLUSTRATED

REVISION:

## HOPPER VIBRATOR ASSEMBLY

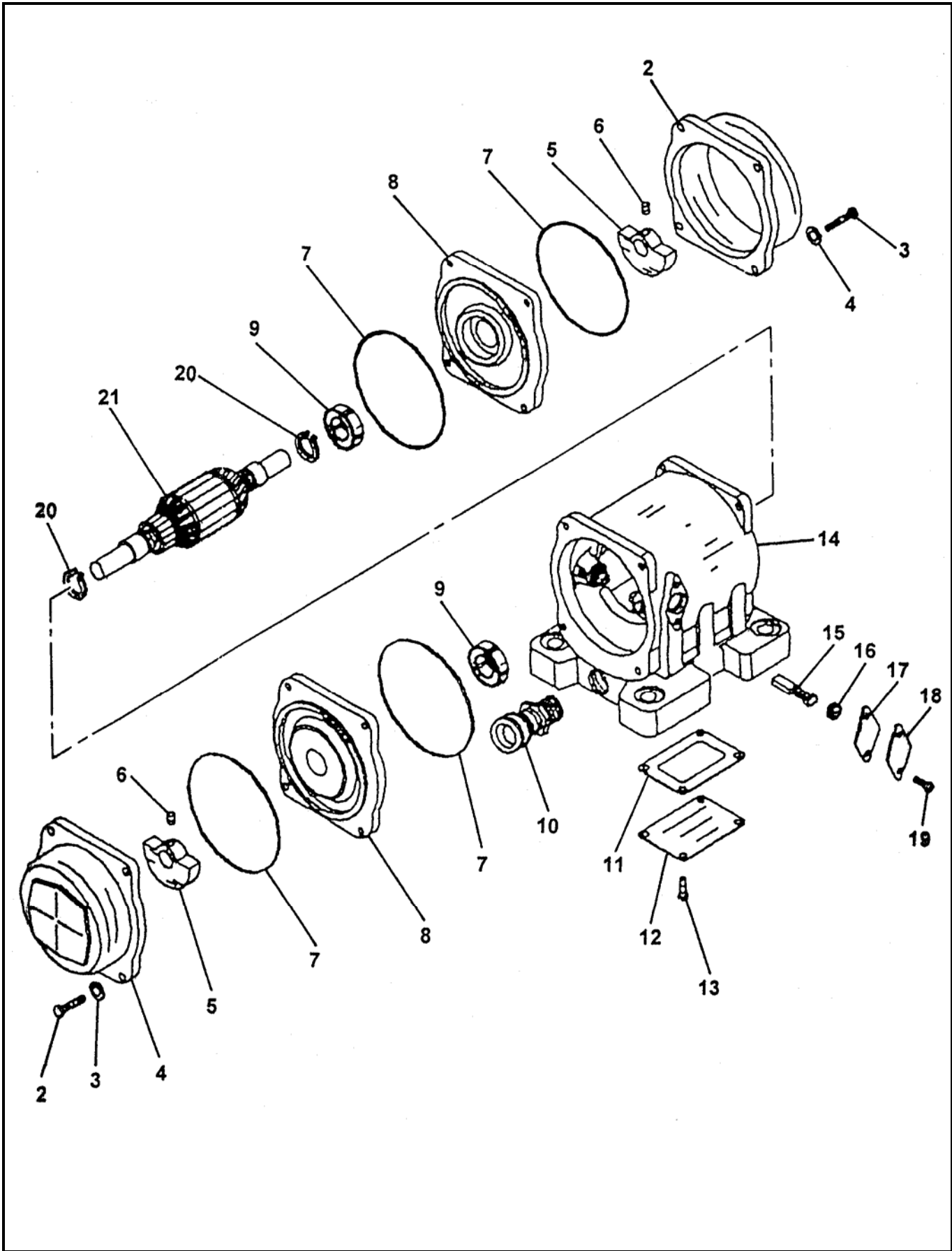

REVISION:





# HOPPER VIBRATOR ASSEMBLY

**A40**  
**PARTS**  
GROUP 80  
FIGURE 02  
PAGE 02

ITEM NO.	REED'S PARTS NO.	DESCRIPTION	QTY
		1 2 3 4 5	
-1	71429	Assembly, Hopper Vibrator (See Group 80, Figure 01 for NHA)	Ref
2		• Cap, End	2
3		• Bolt (attaching parts)	8
4		• Washer, Lock (attaching parts)	8
5		• Weight	2
6		• Screw, Set (attaching parts)	2
7		• O-Ring	4
8		• Bell, End	2
9		• Bearing	2
10		• Holder, Cord	1
11		• Gasket	1
12		• Cover, Box	1
13		• Screw (attaching parts)	4
14		• Sub-Assembly, Housing	1
15		• Brush	1
16		• Cap, Brush	2
17		• Gasket	2
18		• Cover, Brush	2
19		• Screw (attaching parts)	4
20		• Ring, Snap	2
21		• Assembly, Armature	1

DASH (-) ITEM NOT ILLUSTRATED



# OPTIONAL TOOL KIT ASSEMBLY

A40  
PARTS  
GROUP 80  
FIGURE 03  
PAGE 01

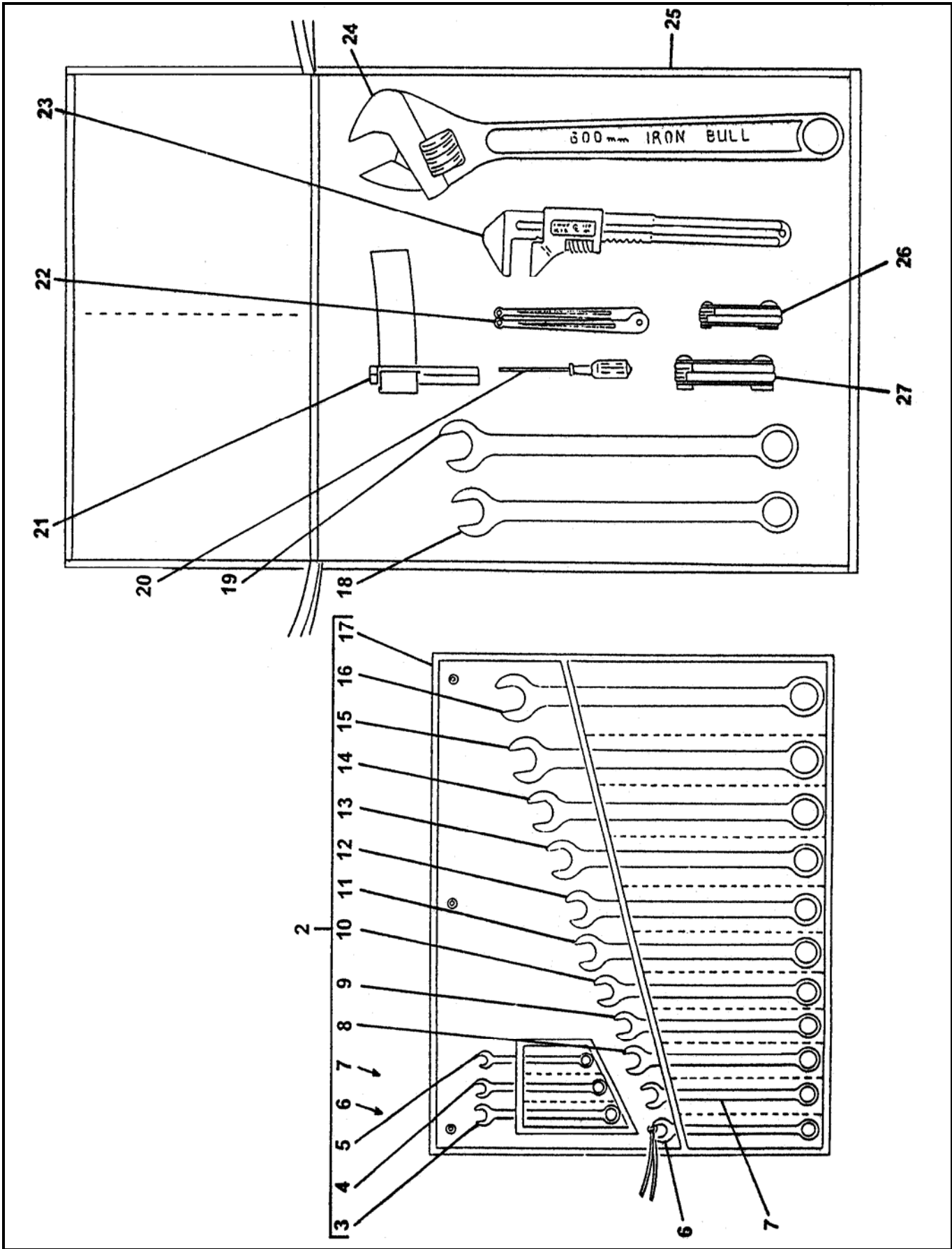

REVISION:



# OPTIONAL TOOL KIT ASSEMBLY

**A40**  
**PARTS**  
GROUP 80  
FIGURE 03  
PAGE 02

ITEM NO.	REED'S PARTS NO.	DESCRIPTION	QTY
		1 2 3 4 5	
-1	79020	Assembly, Optional Tool Kit (See Group 80, Figure 01 for NHA)	Ref
2	79037	• Kit, Wrench	1
3		• • Wrench, 1/2 Inch	1
4		• • Wrench, 7/16 Inch	1
5		• • Wrench, 3/8 Inch	1
6		• • Wrench, 9/16 Inch	1
7		• • Wrench, 5/8 Inch	1
8		• • Wrench, 11/16 Inch	1
9		• • Wrench, 3/4 Inch	1
10		• • Wrench, 13/16 Inch	1
11		• • Wrench, 7/8 Inch	1
12		• • Wrench, 15/16 Inch	1
13		• • Wrench, 1 Inch	1
14		• • Wrench, 1-1/16 Inch	1
15		• • Wrench, 1-1/8 Inch	1
16		• • Wrench, 1-1/4 Inch	1
17		• • Wrap, Plastic	1
18	79036	• Wrench, 1-3/8 Inch	1
19	79028	• Wrench, 1-1/2 Inch	1
20	79038	• Screwdriver	1
21	79814	• Wrench, Strap (for Filter)	1
22	79325	• Wrench, Spanner	1
23	79031	• Wrench, Monkey	1
24	79032	• Wrench, Adjustable 24 Inch	1
25	77502	• Bag, Tool	1
26	79030	• Set, Metric Allen Key (2-8 mm)	1
27	79029	• Set, Standard Allen Key (3/16-3/8 Inch)	1

DASH (-) ITEM NOT ILLUSTRATED



**ACTUATOR-SURGE BRAKES ASSEMBLY**

**A40**  
**PARTS**  
 GROUP 80  
 FIGURE 04  
 PAGE 01



ITEM NO.	REED'S PARTS NO.	DESCRIPTION					QTY
		1	2	3	4	5	
-	BW10312	Assembly, Surge Brake-Model A30HP					Ref
1	BW10310	• Frame, Modification-Surge Brakes					1
2	71025	• Actuator, Surge Brake					1
3	71052	• Hydraulic Brake Kit-12 x 2					1pr
4	87256	• Brake Line Kit					1
5	71030	• Torsion Spring-Brake Kit					2
DASH (-) ITEM NOT ILLUSTRATED							

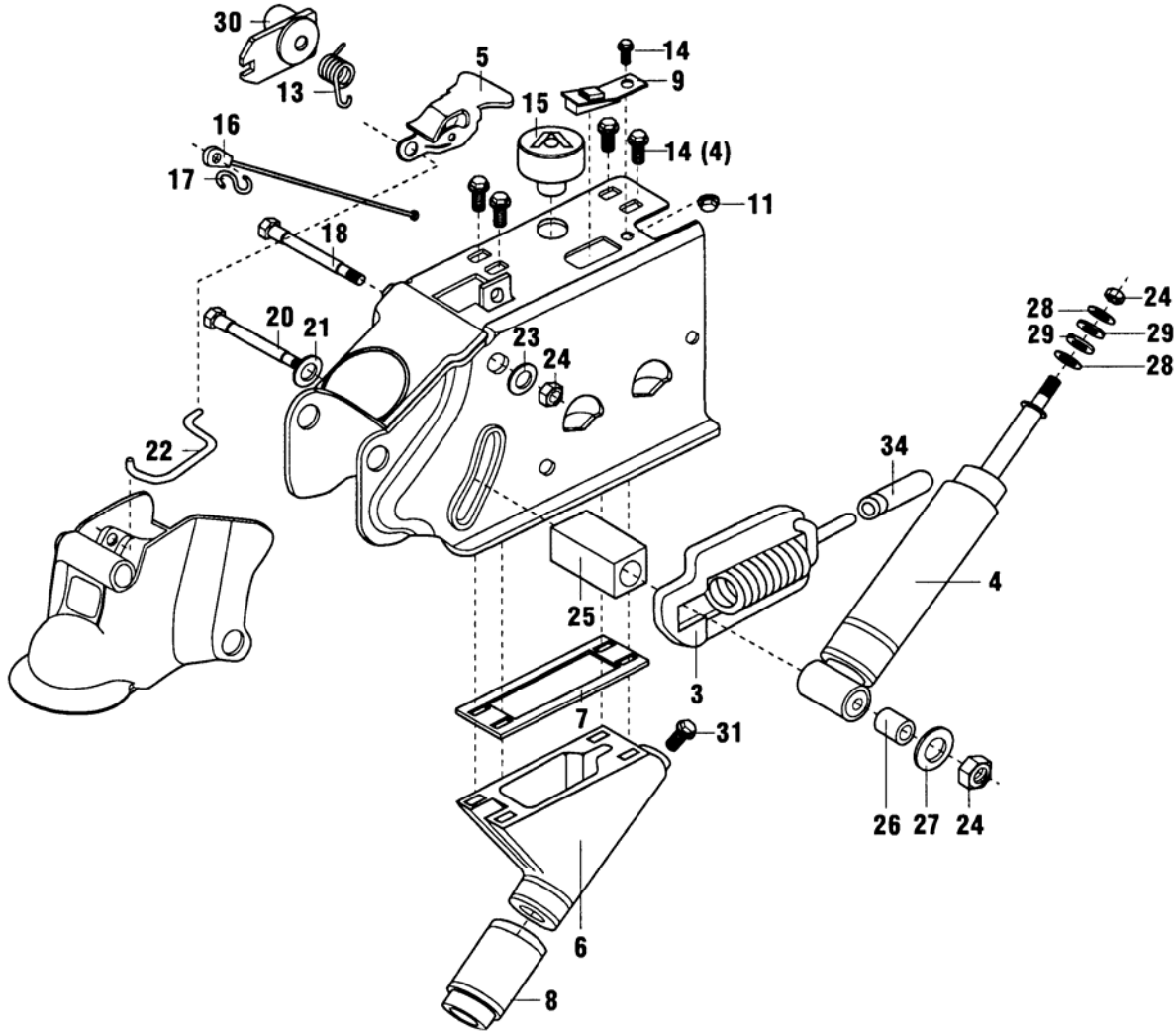

### HYDRAULIC BRAKE ACTUATORS

**TO ORDER:** All kit available for field replacement are numbered. Parts illustrated but not numbered are not available for field replacement. Contact factory service department for further information.

**NOTE:** Save all attaching hardware when disassembling.

KIT #	DESCRIPTION	REPLACEMENT KIT INCLUDES
85830	SHOCK ABSORBER	4, 24-2 EA. 28-2 EA. 29-2 EA.
87478	CAP	15
85842	SHOULDER BOLT	20, 21, 24-2 EA., 25, 26, 27
85844	RELEASE HANDLE	5, 13, 18, 22, 24-3 EA., 30
85849	STOP & SPRING ASSEMBLY	9, 11, 14, 24
85852	PUSH ROD ASSEMBLY	3, 7, 11, 14-5 EA., 16, 17, 24-2 EA., 34, 8, 9
84258	BOOT	8
80777	ORIFICE-DISC BRAKE APPLICATIONS ONLY	31
85837	MASTER CYLINDER-PUSH ROD KIT DRUM BRAKE APPLICATION	3, 6, 7, 8, 9, 11, 14-5 EA., 16, 17, 24-2 EA. 34
85841	MASTER CYLINDER DRUM BRAKE APPLICATION	6, 7, 14-4 EA. MUST ORDER 84258 SEPARATELY
85838	MASTER CYLINDER-PUSH ROD KIT DISC BRAKE APPLICATION	3, 6, 7, 8, 9, 11, 14-5 EA., 16, 17, 24-2 EA. 34, 15
85840	MASTER CYLINDER DISC BRAKE APPLICATION	6, 7, 14-4 EA. MUST ORDER 84258 SEPARATELY





# NON-OPERATOR SIDE HYDRAULIC BRAKE ASSEMBLY

A40  
PARTS  
GROUP 80  
FIGURE 05  
PAGE 01

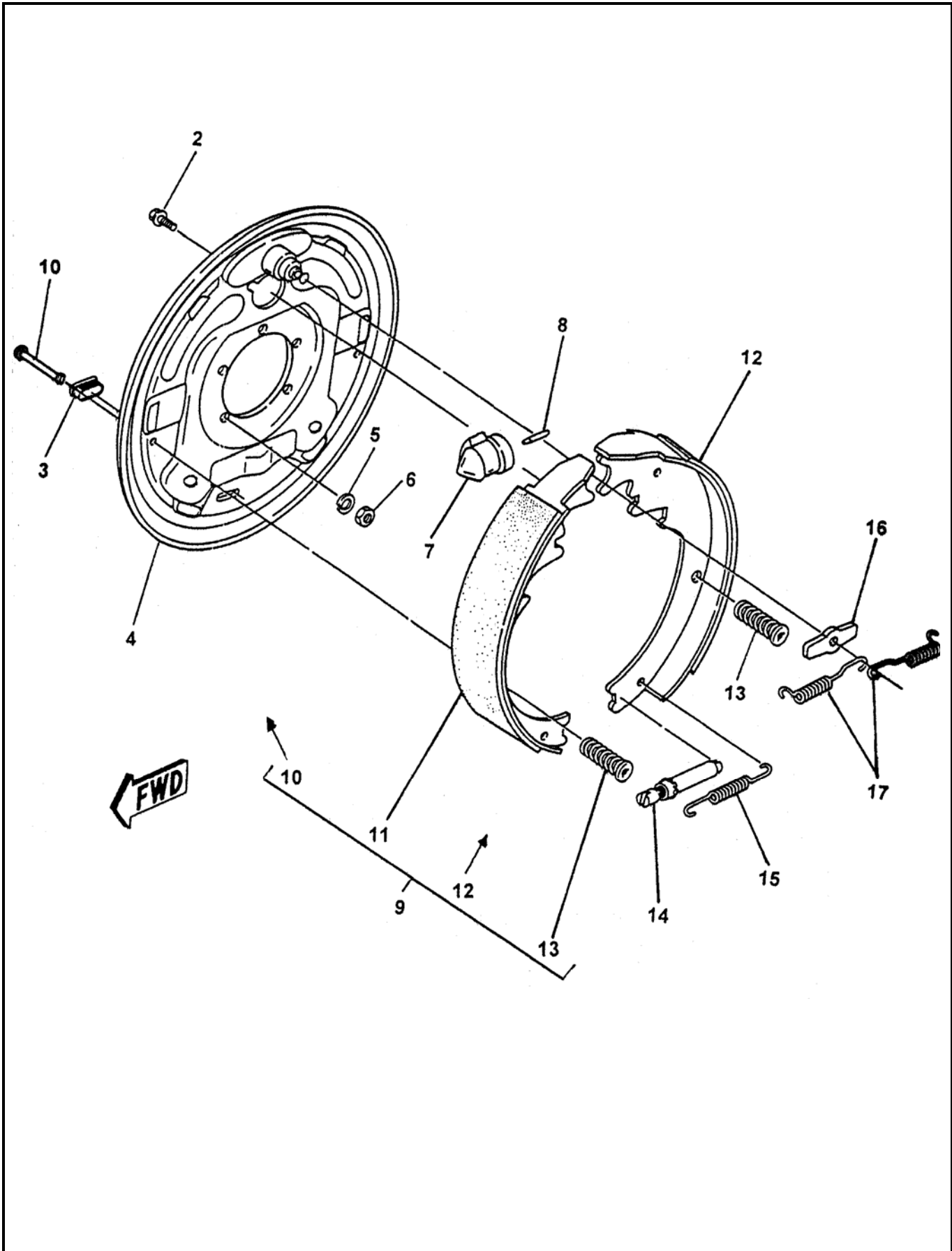

REVISION:



# NON-OPERATOR SIDE HYDRAULIC BRAKE ASSEMBLY

**A40**  
**PARTS**  
GROUP 80  
FIGURE 05  
PAGE 02

ITEM NO.	REED'S PARTS NO.	DESCRIPTION	QTY
		1 2 3 4 5	
-1	80-05	Assembly, Non-Operator Side Hydraulic Brake (See Group 80, Figure 01 for NHA)	Ref
2		• Screw, with Washer	1
3		• Plug	2
4		• Plate, Backing	1
5		• Washer, Lock (attaching parts)	5
6		• Nut, Brake Mounting (attaching parts)	5
7		• Cylinder, Non-Operator Side Brake	1
8		• Rod, Push	1
9		• Kit, Non-Operator Side Shoe and Lining	1
10		• • Pin, Shoe Hold Down	2
11		• • Primary, Non-Operator Side	1
12		• • Secondary, Non-Operator Side	1
13		• • Pin, Shoe Hold Down	2
14		• Assembly, Adjuster	1
15		• Spring, Adjusting Screw	1
16		• Washer, Anchor Post	1
17		• Spring, Retractor	2

DASH (-) ITEM NOT ILLUSTRATED





# OPERATOR SIDE HYDRAULIC BRAKE ASSEMBLY

A40  
PARTS  
GROUP 80  
FIGURE 06  
PAGE 01

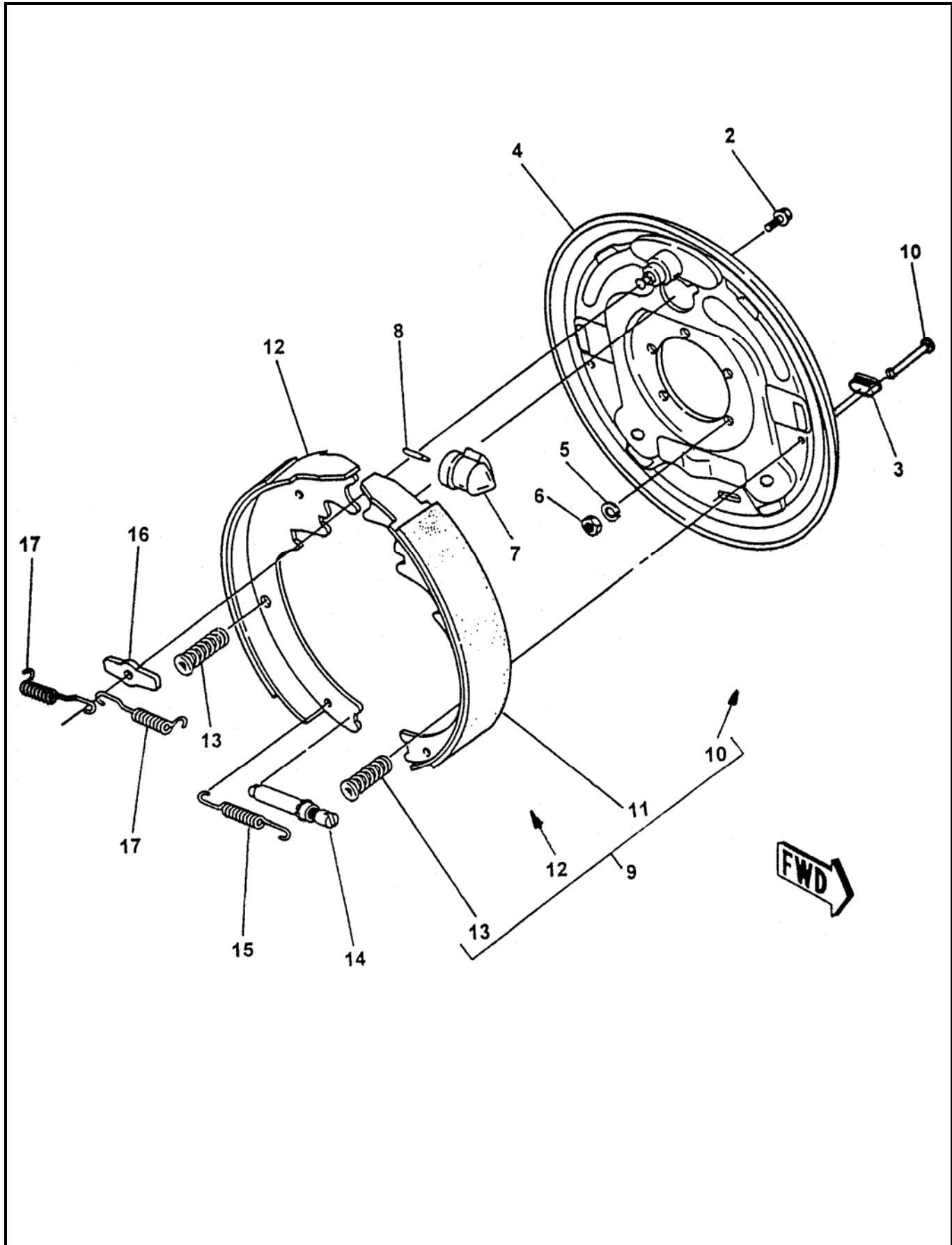

REVISION:



**OPERATOR SIDE  
HYDRAULIC BRAKE ASSEMBLY**

**A40**  
**PARTS**  
GROUP 80  
FIGURE 06  
PAGE 02

ITEM NO.	REED'S PARTS NO.	DESCRIPTION	QTY
		1 2 3 4 5	
-1	80-06	Assembly, Operator Side Hydraulic Brake (See Group 80, Figure 01 for NHA)	Ref
2		• Screw, with Washer	1
3		• Plug	2
4		• Plate, Backing	1
5		• Washer, Lock (attaching parts)	5
6		• Nut, Brake Mounting (attaching parts)	5
7		• Cylinder, Operator Side Brake	1
8		• Rod, Push	1
9		• Kit, Operator Side Shoe and Lining	1
10		• • Pin, Shoe Hold Down	2
11		• • Primary, Operator Side	1
12		• • Secondary, Operator Side	1
13		• • Pin, Shoe Hold Down	2
14		• Assembly, Adjuster	1
15		• Spring, Adjusting Screw	1
16		• Washer, Anchor Post	1
17		• Spring, Retractor	2

DASH (-) ITEM NOT ILLUSTRATED